



Relion® 630 series

Transformer Protection and Control RET630 Application Manual



Document ID: 1MRS756786
Issued: 2011-02-23
Revision: C
Product version: 1.1

© Copyright 2011 ABB. All rights reserved

Copyright

This document and parts thereof must not be reproduced or copied without written permission from ABB, and the contents thereof must not be imparted to a third party, nor used for any unauthorized purpose.

The software or hardware described in this document is furnished under a license and may be used, copied, or disclosed only in accordance with the terms of such license.

Trademarks

ABB and Relion are registered trademarks of ABB Group. All other brand or product names mentioned in this document may be trademarks or registered trademarks of their respective holders.

Warranty

Please inquire about the terms of warranty from your nearest ABB representative.

ABB Oy

Distribution Automation

P.O. Box 699

FI-65101 Vaasa, Finland

Telephone: +358 10 2211

Facsimile: +358 10 22 41094

<http://www.abb.com/substationautomation>

Disclaimer

The data, examples and diagrams in this manual are included solely for the concept or product description and are not to be deemed as a statement of guaranteed properties. All persons responsible for applying the equipment addressed in this manual must satisfy themselves that each intended application is suitable and acceptable, including that any applicable safety or other operational requirements are complied with. In particular, any risks in applications where a system failure and/or product failure would create a risk for harm to property or persons (including but not limited to personal injuries or death) shall be the sole responsibility of the person or entity applying the equipment, and those so responsible are hereby requested to ensure that all measures are taken to exclude or mitigate such risks.

This document has been carefully checked by ABB but deviations cannot be completely ruled out. In case any errors are detected, the reader is kindly requested to notify the manufacturer. Other than under explicit contractual commitments, in no event shall ABB be responsible or liable for any loss or damage resulting from the use of this manual or the application of the equipment.

Conformity

This product complies with the directive of the Council of the European Communities on the approximation of the laws of the Member States relating to electromagnetic compatibility (EMC Directive 2004/108/EC) and concerning electrical equipment for use within specified voltage limits (Low-voltage directive 2006/95/EC). This conformity is the result of tests conducted by ABB in accordance with the product standards EN 50263 and EN 60255-26 for the EMC directive, and with the product standards EN 60255-1 and EN 60255-27 for the low voltage directive. The IED is designed in accordance with the international standards of the IEC 60255 series.

Table of contents

Section 1	Introduction.....	5
	This manual.....	5
	Intended audience.....	5
	Product documentation.....	6
	Product documentation set.....	6
	Document revision history.....	7
	Related documentation.....	8
	Symbols and conventions.....	8
	Safety indication symbols.....	8
	Manual conventions.....	9
	Functions, codes and symbols.....	9
Section 2	RET630 overview.....	13
	Overview.....	13
	Product version history.....	13
	PCM600 and IED connectivity package version.....	13
	Operation functionality.....	14
	Product variants.....	14
	Optional functions.....	14
	Physical hardware.....	14
	Local HMI.....	16
	Display.....	16
	LEDs.....	19
	Keypad.....	19
	Web HMI.....	19
	Authorization.....	21
	Communication.....	21
Section 3	RET630 variants.....	23
	Presentation of preconfigurations.....	23
	Preconfigurations.....	24
	Preconfiguration A for two-winding HV/MV transformer.....	26
	Application.....	26
	Functions.....	28
	Input/output signal interfaces.....	30
	Preprocessing blocks and fixed signals.....	31
	Control functions.....	32
	Transformer bay control QCCBAY.....	32
	Apparatus control SCILO, GNRLCSWI, DAXCBR, DAXSWI.....	32

Table of contents

Protection functions.....	34
Differential protection for two-winding transformer TR2PTDF.....	34
Non-directional overcurrent protection PHxPTOC.....	35
Negative-sequence overcurrent protection NSPTOC.....	36
Non-directional earth-fault protection EFxPTOC.....	36
Thermal overload protection T2PTTR.....	37
Three-phase overvoltage protection PHPTOV.....	38
Three-phase undervoltage protection PHPTUV.....	39
Circuit-breaker failure protection CCBRBRF.....	40
Tripping logic TRPPTRC.....	41
Combined operate and start alarm signal.....	41
Other output and alarm signals.....	42
Supervision functions.....	42
Trip circuit supervision TCSSCBR.....	42
Fuse failure supervision SEQRFUF.....	42
Circuit-breaker condition monitoring SSCBR.....	43
Measurement and analog recording functions.....	43
Binary recording and LED configuration.....	45
Preconfiguration B for two-winding HV/MV transformer, including numerical REF protection.....	48
Application.....	48
Functions.....	49
Input/output signal interfaces.....	51
Preprocessing blocks and fixed signals	53
Control functions.....	53
Transformer bay control QCCBAY.....	53
Apparatus control SCILO, GNRLCSWI, DAXCBR, DAXSWI.....	53
Protection functions.....	55
Differential protection for two-winding transformer TR2PTDF.....	55
Stabilized restricted earth-fault protection LREFPNDF.....	56
Non-directional overcurrent protection PHxPTOC.....	56
Negative-sequence overcurrent protection NSPTOC.....	57
Non-directional earth-fault protection EFxPTOC.....	58
Thermal overload protection T2PTTR.....	59
Three-phase overvoltage protection PHPTOV.....	60
Three-phase undervoltage protection PHPTUV.....	61
Circuit-breaker failure protection CCBRBRF.....	62
Tripping logic TRPPTRC.....	63
Combined operate and start alarm signal.....	63
Other output and alarm signals.....	64
Supervision functions.....	64

	Trip circuit supervision TCSSCBR.....	64
	Circuit-breaker condition monitoring SSCBR.....	64
	Measurement and analog recording functions.....	65
	Binary recording and LED configuration.....	66
Section 4	Requirements for measurement transformers.....	71
	Current transformers.....	71
	Current transformer requirements for non-directional overcurrent protection.....	71
	Current transformer accuracy class and accuracy limit factor.....	71
	Non-directional overcurrent protection.....	72
	Example for non-directional overcurrent protection.....	73
	Current transformer requirements for differential protection.....	74
Section 5	Glossary.....	79

Section 1 Introduction

1.1 This manual

The application manual contains descriptions of preconfigurations. The manual can be used as a reference for configuring control, protection, measurement, recording and LED functions. The manual can also be used when creating configurations according to specific application requirements.

1.2 Intended audience

This manual addresses the protection and control engineer responsible for planning, pre-engineering and engineering.

The protection and control engineer must be experienced in electrical power engineering and have knowledge of related technology, such as communication and protocols.

1.3 Product documentation

1.3.1 Product documentation set

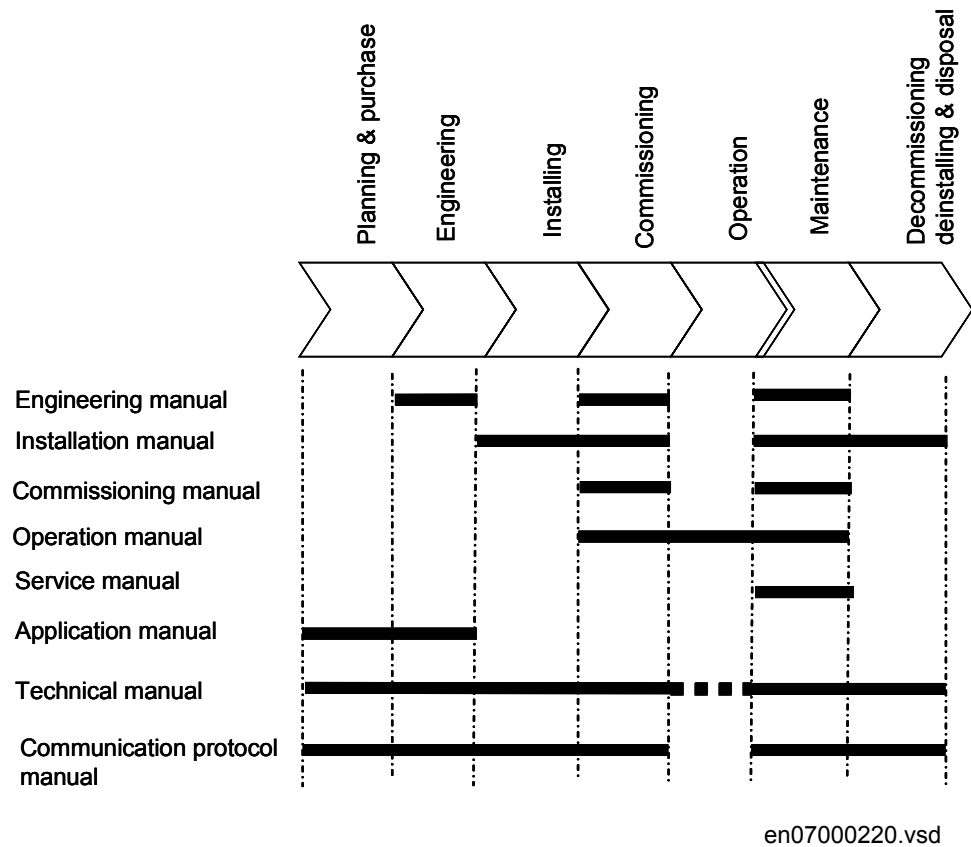

Figure 1: The intended use of manuals in different lifecycles

The engineering manual contains instructions on how to engineer the IEDs using the different tools in PCM600. The manual provides instructions on how to set up a PCM600 project and insert IEDs to the project structure. The manual also recommends a sequence for engineering of protection and control functions, LHMI functions as well as communication engineering for IEC 60870-5-103, IEC 61850 and DNP3.

The installation manual contains instructions on how to install the IED. The manual provides procedures for mechanical and electrical installation. The chapters are organized in chronological order in which the IED should be installed.

The commissioning manual contains instructions on how to commission the IED. The manual can also be used by system engineers and maintenance personnel for assistance during the testing phase. The manual provides procedures for checking of external circuitry and energizing the IED, parameter setting and configuration as

well as verifying settings by secondary injection. The manual describes the process of testing an IED in a substation which is not in service. The chapters are organized in chronological order in which the IED should be commissioned.

The operation manual contains instructions on how to operate the IED once it has been commissioned. The manual provides instructions for monitoring, controlling and setting the IED. The manual also describes how to identify disturbances and how to view calculated and measured power grid data to determine the cause of a fault.

The service manual contains instructions on how to service and maintain the IED. The manual also provides procedures for de-energizing, de-commissioning and disposal of the IED.

The application manual contains descriptions of preconfigurations. The manual can be used as a reference for configuring control, protection, measurement, recording and LED functions. The manual can also be used when creating configurations according to specific application requirements.

The technical manual contains application and functionality descriptions and lists function blocks, logic diagrams, input and output signals, setting parameters and technical data sorted per function. The manual can be used as a technical reference during the engineering phase, installation and commissioning phase, and during normal service.

The communication protocol manual describes a communication protocol supported by the IED. The manual concentrates on vendor-specific implementations.

The point list manual describes the outlook and properties of the data points specific to the IED. The manual should be used in conjunction with the corresponding communication protocol manual.



The service manual is not available yet.

1.3.2

Document revision history

Document revision/date	Product version	History
A/2009-09-15	1.0	First release
B/2009-12-23	1.0	Content updated
C/2011-02-23	1.1	Content updated to correspond to the product version



Download the latest documents from the ABB web site <http://www.abb.com/substationautomation>.

1.3.3 Related documentation

Name of the document	Document ID
DNP3 Communication Protocol Manual	1MRS756789
IEC 61850 Communication Protocol Manual	1MRS756793
IEC 60870-5-103 Communication Protocol Manual	1MRS757203
Installation Manual	1MRS755958
Operation Manual	1MRS756509
Technical Manual	1MRS756508
Engineering Manual	1MRS756800
Commissioning Manual	1MRS756801

1.4 Symbols and conventions

1.4.1 Safety indication symbols



The electrical warning icon indicates the presence of a hazard which could result in electrical shock.



The warning icon indicates the presence of a hazard which could result in personal injury.



The caution icon indicates important information or warning related to the concept discussed in the text. It might indicate the presence of a hazard which could result in corruption of software or damage to equipment or property.



The information icon alerts the reader of important facts and conditions.





The tip icon indicates advice on, for example, how to design your project or how to use a certain function.

Although warning hazards are related to personal injury, it is necessary to understand that under certain operational conditions, operation of damaged equipment may result in degraded process performance leading to personal injury or death. Therefore, comply fully with all warning and caution notices.

1.4.2 Manual conventions

Conventions used in IED manuals. A particular convention may not be used in this manual.

- Abbreviations and acronyms in this manual are spelled out in the glossary. The glossary also contains definitions of important terms.
- Push button navigation in the LHMI menu structure is presented by using the push button icons, for example:
To navigate between the options, use  and .
- HMI menu paths are presented in bold, for example:
Select **Main menu/Settings**.
- LHMI messages are shown in Courier font, for example:
To save the changes in non-volatile memory, select `Yes` and press .
- Parameter names are shown in italics, for example:
The function can be enabled and disabled with the *Operation* setting.
- The ^ character in front of an input or output signal name in the function block symbol given for a function, indicates that the user can set an own signal name in PCM600.
- The * character after an input or output signal name in the function block symbol given for a function, indicates that the signal must be connected to another function block in the application configuration to achieve a valid application configuration.

1.4.3 Functions, codes and symbols

Table 1: Functions included in RET630

Functionality	IEC 61850	IEC 60617	ANSI
Protection			
Three-phase non-directional overcurrent, low stage	PHLPTOC	3I>	51P-1
Three-phase non-directional overcurrent, high stage	PHHPTOC	3I>>	51P-2
Three-phase non-directional overcurrent, instantaneous stage	PHIPTOC	3I>>>	50P/51P
Three-phase directional overcurrent, low stage	DPHLPDOC	3I> →	67-1
Three-phase directional overcurrent, high stage	DPHHPDOC	3I>> →	67-2
Non-directional earth-fault, low stage	EFLPTOC	I0>	51N-1
Non-directional earth-fault, high stage	EFHPTOC	I0>>	51N-2
Directional earth-fault, low stage	DEFLPDEF	I0> ->	67N-1
Directional earth-fault, high stage	DEFHPDEF	I0>> →	67N-2
Stabilised restricted earth-fault	LREFPNDF	dI0Lo>	87NL
High-impedance-based restricted earth-fault protection	HREFPDIF	dI0Hi>	87NH
Table continues on next page			

Functionality	IEC 61850	IEC 60617	ANSI
Negative-sequence overcurrent	NSPTOC	I2>	46
Three-phase thermal overload for transformers	T2PTTR	3Ith>T	49T
Three-phase current inrush detection	INRPHAR	3I2f>	68
Transformer differential protection for two-winding transformers	TR2PTDF	3dl>T	87T
Three-phase overvoltage (LV side)	PHPTOV	3U>	59
Three-phase undervoltage (LV side)	PHPTUV	3U<	27
Positive-sequence overvoltage	PSPTOV	U1>	47O+
Positive-sequence undervoltage	PSPTUV	U1<	47U+
Negative-sequence overvoltage	NSPTOV	U2>	47O-
Residual overvoltage	ROVPTOV	U0>	59G
Frequency gradient	DAPFRC	df/dt>	81R
Overfrequency	DAPTOF	f>	81O
Underfrequency	DAPTUF	f<	81U
Overexcitation protection	OEPVPH	U/f>	24
Three-phase underimpedance protection	UZPDIS	Z< GT	21GT
Circuit-breaker failure (HV side)	CCBRBRF	3I>/I0>BF	51BF/51NBF
Tripping logic	TRPPTRC	I → O	94
Multipurpose analog protection	MAPGAPC	MAP	MAP
Control			
Bay control	QCCBAY	CBAY	CBAY
Interlocking interface	SCILO	3	3
Circuit breaker/disconnector control	GNRLCSWI	I ↔ O CB/DC	I ↔ O CB/DC
Circuit breaker	DAXCBR	I ↔ O CB	I ↔ O CB
Disconnector	DAXSWI	I ↔ O DC	I ↔ O DC
Local/remote switch interface	LOCREM	R/L	R/L
Synchrocheck	SYNCRSYN	SYNC	25
Tap changer control with voltage regulator	OLATCC	COLTC	90V
Generic process I/O			
Single point control (8 signals)	SPC8GGIO		
Double point indication	DPGGIO		
Single point indication	SPGGIO		
Generic measured value	MVGGIO		
Logic rotating switch for function selection and LHMI presentation	SLGGIO		
Selector mini switch	VSGGIO		
Pulse counter for energy metering	PCGGIO		
Event counter	CNTGGIO		
Table continues on next page			

Functionality	IEC 61850	IEC 60617	ANSI
Supervision and monitoring			
Circuit-breaker condition monitoring (HV side)	SSCBR	CBCM	CBCM
Fuse failure supervision	SEQRFUF	FUSEF	60
Current circuit supervision	CCRDIF	MCS 3I	MCS 3I
Trip-circuit supervision	TCSSCBR	TCS	TCM
Tap position indication	TPOSSLTC	TPOSM	84M
Energy monitoring	EPDMMTR	E	E
Station battery supervision	SPVNZBAT	U<>	U<>
Measured value limit supervision	MVEXP		
Measurement			
Three-phase current	CMMXU	3I	3I
Three-phase voltage (phase-to-phase)	VPPMMXU	3Upp	3Vpp
Three-phase voltage (phase-to-earth)	VPHMMXU	3Upe	3Vpe
Residual current measurement	RESCMMXU	I0	I0
Residual voltage measurement	RESVMMXU	U0	Vn
Power monitoring with P, Q, S, power factor, frequency	PWRMMXU	PQf	PQf
Sequence current measurement	CSMSQI	I1, I2	I1, I2
Sequence voltage measurement	VSMSQI	U1, U2	V1, V2
Disturbance recorder function			
Analog channels 1-10 (samples)	A1RADR	ACH1	ACH1
Analog channels 11-20 (samples)	A2RADR	ACH2	ACH2
Analog channels 21-30 (calc. val.)	A3RADR	ACH3	ACH3
Analog channels 31-40 (calc. val.)	A4RADR	ACH4	ACH4
Binary channels 1-16	B1RBDR	BCH1	BCH1
Binary channels 17-32	B2RBDR	BCH2	BCH2
Binary channels 33-48	B3RBDR	BCH3	BCH3
Binary channels 49-64	B4RBDR	BCH4	BCH4
Station communication (GOOSE)			
Binary receive	GOOSEBINRCV		
Double point receive	GOOSEDPRCV		
Interlock receive	GOOSEINTLKRCV		
Integer receive	GOOSEINTRCV		
Measured value receive	GOOSEMVRCV		
Single point receive	GOOSESRCV		

Section 2 RET630 overview

2.1 Overview

RET630 is a comprehensive transformer management IED for protection, control, measuring and supervision of power transformers, unit and step-up transformers including power generator-transformer blocks in utility and industry power distribution networks. RET630 is a member of ABB's Relion® product family and a part of its 630 series characterized by functional scalability and flexible configurability. RET630 also features necessary control functions constituting an ideal solution for transformer bay control and voltage regulation.

The supported communication protocols including IEC 61850 offer seamless connectivity to various station automation and SCADA systems.

2.1.1 Product version history

Product version	Product history
1.0	First release
1.1	<ul style="list-style-type: none"> • Support for IEC 60870-5-103 communication protocol • Analog GOOSE • RTD module • Voltage control of transformers (single and parallel) • Three-phase under-impedance protection • Overexcitation protection

2.1.2 PCM600 and IED connectivity package version

- Protection and Control IED Manager PCM600 Ver. 2.3 or later
- ABB RET630 Connectivity Package Ver. 1.1 or later
 - Application Configuration
 - Parameter Setting
 - Signal Matrix
 - Signal Monitoring
 - Disturbance Handling
 - Event Viewer
 - Graphical Display Editor
 - Hardware Configuration
 - IED Users
 - Communication Management
 - Configuration Migration



Download connectivity packages from the ABB web site <http://www.abb.com/substationautomation>

2.2 Operation functionality

2.2.1 Product variants

The IED capabilities can be adjusted by selecting a product variant. The IED capabilities can be extended by adding HW and/or SW options to the basic variant. For example, the physical communication connector can be either an electrical or optical Ethernet connector.

The number of binary inputs and outputs depends on the amount of the optional BIO modules selected. For a 4U IED, it is possible to take 2 additional BIO modules at the maximum, and for a 6U IED, it is possible to take 4 additional BIO modules at the maximum.

- Basic variant: 14 binary inputs and 9 binary outputs
- With one optional BIO module: 23 binary inputs and 18 binary outputs
- With two optional BIO modules: 32 binary inputs and 27 binary outputs
- With three optional BIO modules: 41 binary inputs and 36 binary outputs
- With four optional BIO modules: 50 binary inputs and 45 binary outputs

2.2.2 Optional functions

Some of the available functions are optional, that is, they are included in the delivered product only when defined by the order code.

- Phase sequence voltage functions (optional in v. 1.0, always included in v. 1.1)
 - Positive-sequence overvoltage protection
 - Positive-sequence undervoltage protection
 - Negative-sequence overvoltage protection
- Automatic voltage regulator (optional in v. 1.1)
- Underimpedance protection (optional in v. 1.1)
- Overexcitation protection (optional in v. 1.1)

2.3 Physical hardware

The mechanical design of the IED is based on a robust mechanical rack. The HW design is based on the possibility to adapt the HW module configuration to different customer applications.

Table 2: IED contents

Content options	
LHMI	
Communication and CPU module	1 electrical Ethernet connector for the detached LHMI module (the connector must not be used for any other purpose) 1 Ethernet connector for communication (selectable electrical or optical connector) IRIG-B (external time synchronization) connector 1 fibre optic connector pair for serial communication (selectable plastic or glass fibre) 14 binary control inputs
Auxiliary power/binary output module	48-125 V DC or 100-240 V AC/110-250 V DC Input contacts for the supervision of the auxiliary supply battery level 3 normally open power output contacts with TCS 3 normally open power output contacts 1 change-over signalling contact 3 additional signalling contacts 1 dedicated internal fault output contact
Analog input module	7 or 8 current inputs (1/5 A) 2 or 3 voltage inputs (100/110/115/120 V) Max. 1 accurate current input for sensitive earth-fault protection (0.1/0.5 A)
Binary input and output module	3 normally open power output contacts 1 change-over signalling contact 5 additional signalling contacts 9 binary control inputs
RTD input and mA output module	8 RTD-inputs (sensor/R/V/mA) 4 outputs (mA)

All external wiring, that is CT and VT connectors, BI/O connectors, power supply connector and communication connections, can be disconnected from the IED modules with wiring, for example, in service situations. The CT connectors have a build-in mechanism which automatically short-circuits CT secondaries when the connector is disconnected from the IED.

2.4 Local HMI

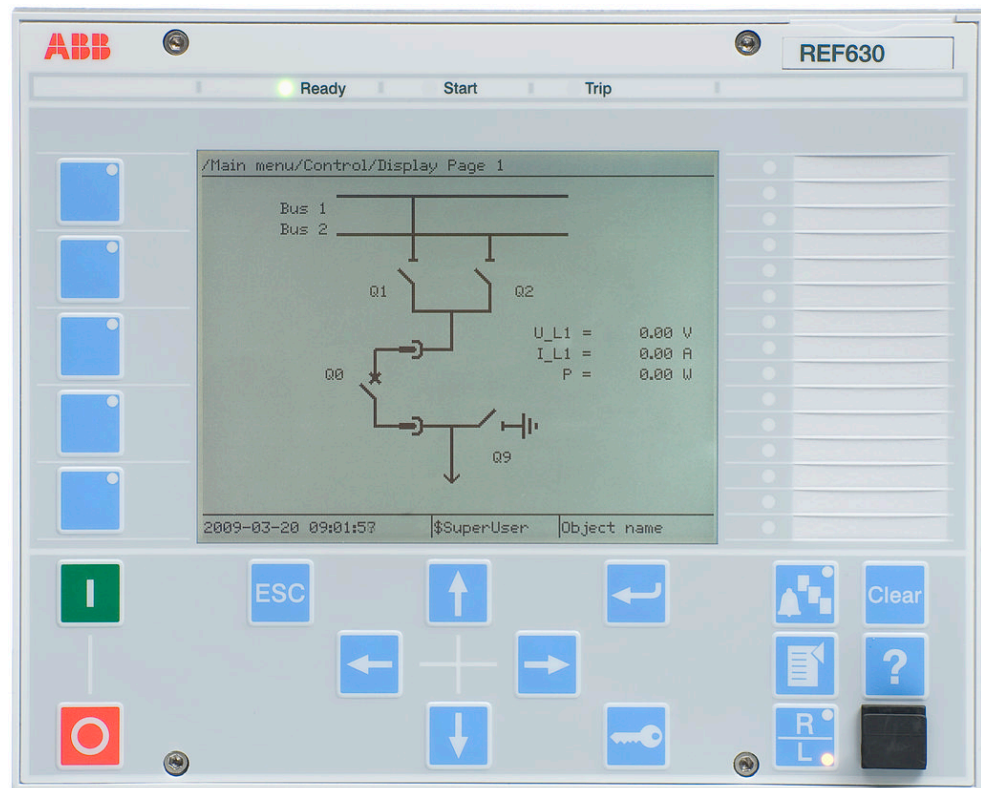

Figure 2: 19" LHMI

The LHMI of the IED contains the following elements:

- Display
- Buttons
- LED indicators
- Communication port

The LHMI is used for setting, monitoring and controlling .

2.4.1 Display

The LHMI includes a graphical monochrome display with a resolution of 320 x 240 pixels. The character size can vary. The amount of characters and rows fitting the view depends on the character size and the view that is shown.

The display view is divided into four basic areas.

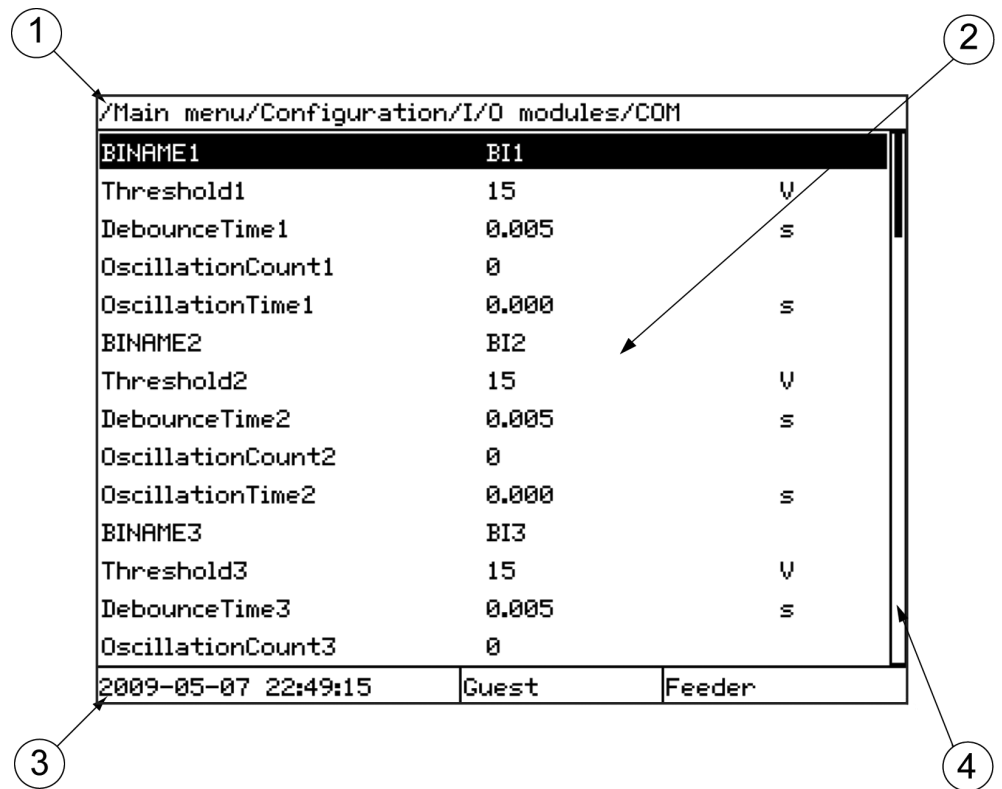

Figure 3: Display layout

- 1 Path
- 2 Content
- 3 Status
- 4 Scroll bar (appears when needed)

The function button panel shows on request what actions are possible with the function buttons. Each function button has a LED indication that can be used as a feedback signal for the function button control action. The LED is connected to the required signal with PCM600.

Control LCD_FN1_OFF		
Control LCD_FN2_OFF		
Control LCD_FN3_OFF		
Menu shortcut Events		
Menu shortcut Disturbance records		
	Guest	Feeder

Figure 4: Function button panel

The alarm LED panel shows on request the alarm text labels for the alarm LEDs.

/Main menu	1	
Control	2	LOCKED_BY_AR
Events	3	
Measurements		TC_ALARM
Disturbance records		
Settings		
Configuration		
Monitoring		
Test		
Information		
Clear		
Language		
2009-04-24 00:53:43	Guest	

Figure 5: Alarm LED panel

The function button and alarm LED panels are not visible at the same time. Each panel is shown by pressing one of the function buttons or the Multipage button. Pressing the ESC button clears the panel from the display. Both the panels have dynamic width that depends on the label string length that the panel contains.

2.4.2 LEDs

The LHMI includes three protection indicators above the display: Ready, Start and Trip.

There are also 15 matrix programmable alarm LEDs on front of the LHMI. Each LED can indicate three states with the colors: green, yellow and red. The alarm texts related to each three-color LED are divided into three pages. Altogether, the 15 physical three-color LEDs can indicate 45 different alarms. The LEDs can be configured with PCM600 and the operation mode can be selected with the LHMI, WHMI or PCM600.

2.4.3 Keypad

The LHMI keypad contains push-buttons which are used to navigate in different views or menus. With the push-buttons you can control objects in the single-line diagram, for example, circuit breakers or disconnectors. The push-buttons are also used to acknowledge alarms, reset indications, provide help and switch between local and remote control mode.

The keypad also contains programmable push-buttons that can be configured either as menu shortcut or control buttons.

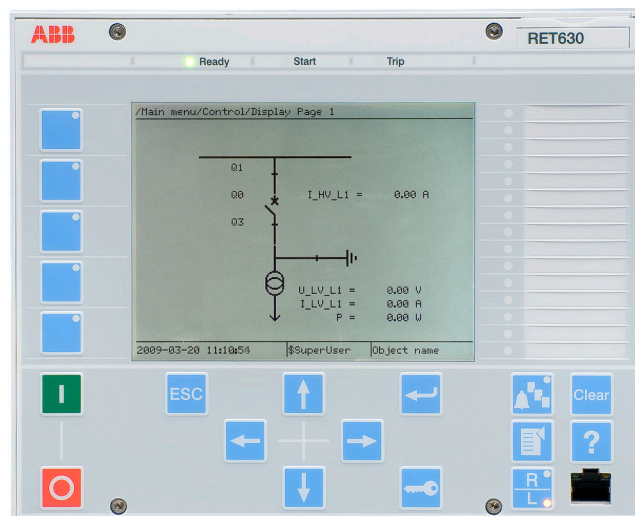

Figure 6: LHMI keypad with object control, navigation and command push-buttons and RJ-45 communication port

2.5 Web HMI

The WHMI enables the user to access the IED via a web browser. The supported web browser version is Internet Explorer 7.0 or later.



WHMI is disabled by default. To enable the WHMI, select **Main menu/Configuration/HMI/Web HMI/Operation** via the LHMI.

WHMI offers several functions.

- Alarm indications and event lists
- System supervision
- Parameter settings
- Measurement display
- Disturbance records
- Phasor diagram

The menu tree structure on the WHMI is almost identical to the one on the LHMI.

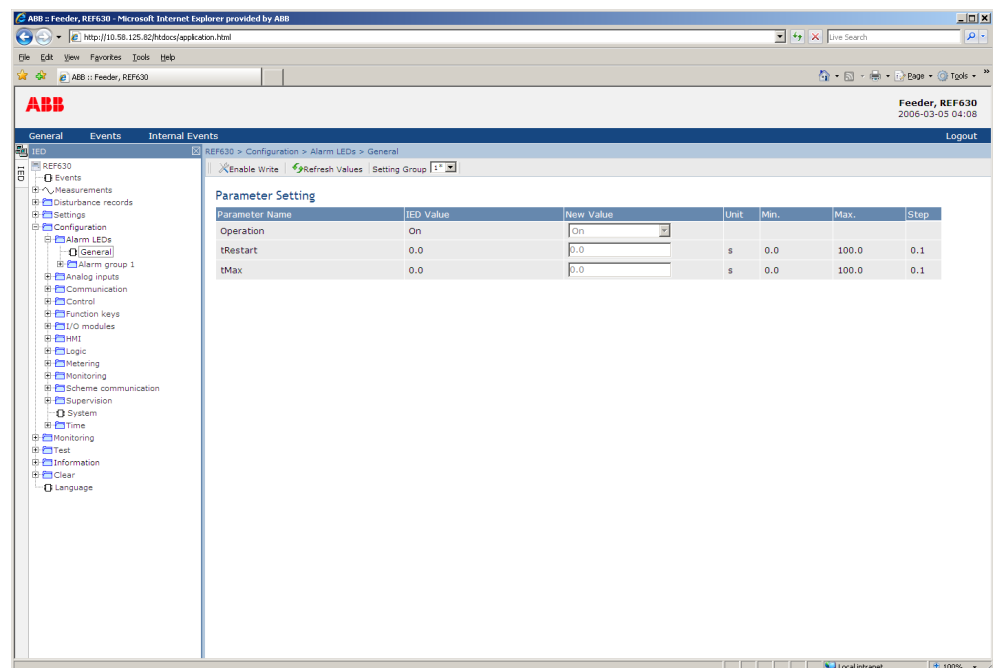

Figure 7: Example view of the WHMI

The WHMI can be accessed locally and remotely.

- Locally by connecting the user's computer to the IED via the front communication port.
- Remotely over LAN/WAN.

2.6 Authorization

The user categories are predefined for the LHMI and WHMI, each with different rights.

The IED users can be created, deleted and edited only with PCM600. One user can belong to one or several user categories.



At delivery, the user has full access until users are created with PCM600. Logging on is not required for the LHMI.

Table 3: *Predefined user categories*

User category	User rights
SystemOperator	Control from LHMI, no bypass
ProtectionEngineer	All settings
DesignEngineer	Application configuration
UserAdministrator	User and password administration



All changes in user management settings will cause an IED reboot.

2.7 Communication

The IED supports communication protocols IEC 61850-8-1, IEC 60870-5-103 and DNP3 over TCP/IP.

All operational information and controls are available through these protocols. However, some communication functionality, for example, horizontal communication (GOOSE) between the IEDs, is only enabled by the IEC 61850-8-1 communication protocol.

Disturbance files are accessed using the IEC 61850 or IEC 60870-5-103 protocols. Disturbance files are also available to any Ethernet based application in the standard COMTRADE format. The IED can send binary signals to other IEDs (so called horizontal communication) using the IEC 61850-8-1 GOOSE (Generic Object Oriented Substation Event) profile. Binary GOOSE messaging can, for example, be employed for protection and interlocking-based protection schemes. The IED meets the GOOSE performance requirements for tripping applications in distribution substations, as defined by the IEC 61850 standard. Further, the IED supports the sending and receiving of analog values using GOOSE messaging. Analog GOOSE messaging enables fast transfer of analog measurement values

over the station bus, thus facilitating for example sharing of RTD input values, such as surrounding temperature values, to other IED applications. The IED interoperates with other IEC 61850 compliant IEDs, tools and systems and simultaneously reports events to five different clients on the IEC 61850 station bus. For a system using DNP3 over TCP/IP, events can be sent to four different masters. For systems using IEC 60870-5-103 IED can be connected to one master in a station bus with star-topology.

All communication connectors, except for the front port connector, are placed on integrated communication modules. The IED is connected to Ethernet-based communication systems via the RJ-45 connector (10/100BASE-TX) or the fibre-optic multimode LC connector (100BASE-FX).

IEC 60870-5-103 is available from optical serial port where it is possible to use serial glass fibre (ST connector) or serial plastic fibre (snap-in connector).

The IED supports SNTP, DNP3 and IRIG-B time synchronization methods with a time-stamping resolution of 1 ms.

The IED supports the following time synchronization methods with a timestamping resolution of 1 ms:

Ethernet communication based:

- SNTP (simple network time protocol)
- DNP3

With special time synchronization wiring:

- IRIG-B

IEC 60870-5-103 serial communication has a time-stamping resolution of 10 ms.

Section 3 RET630 variants

3.1 Presentation of preconfigurations

The 630 series IEDs are offered with optional factory-made preconfigurations for various applications. The preconfigurations contribute to faster commissioning and less engineering of the IED. The preconfigurations include default functionality typically needed for a specific application. Each preconfiguration is adaptable using the Protection and Control IED Manager PCM600. By adapting the preconfiguration the IED can be configured to suit the particular application.

The adaptation of the preconfiguration may include adding or removing of protection, control and other functions according to the specific application, changing of the default parameter settings, configuration of the default alarms and event recorder settings including the texts shown in the HMI, configuration of the LEDs and function buttons, and adaptation of the default single-line diagram.

In addition, the adaptation of the preconfiguration always includes communication engineering to configure the communication according to the functionality of the IED. The communication engineering is done using the communication configuration function of PCM600.

The functional diagrams describe the IED's functionality from the protection, measuring, condition monitoring, disturbance recording, control and interlocking perspective. Diagrams show the default functionality with simple symbol logics forming principle diagrams. The external connections to primary devices are also shown, stating the default connections to measuring transformers. The positive measuring direction of directional protection functions is towards the low voltage side.

The functional diagrams are divided into sections which each constitute one functional entity. The external connections are also divided into sections. Only the relevant connections for a particular functional entity are presented in each section.

Protection function blocks are part of the functional diagram. They are identified based on their IEC 61850 name but the IEC based symbol and the ANSI function number are also included. Some function blocks, such as PHHPTOC, are used several times in the configuration. To separate the blocks from each other, the IEC 61850 name, IEC symbol and ANSI function number are appended with a running number, an instance number, from one onwards.

3.1.1

Preconfigurations

Table 4: *RET630 preconfiguration ordering options*

Description	Preconfiguration		
	A	B	n
Preconfiguration A for two-winding HV/MV transformer	A		
Preconfiguration B for two-winding HV/MV transformer, including numerical REF protection		B	
Number of instances available			n

Table 5: *Functions used in preconfigurations. Column 'n' shows the total number of available function instances regardless of the preconfiguration selected.*

Functionality	A	B	n
Protection			
Three-phase non-directional overcurrent, low stage (LV side)	1	1	2
Three-phase non-directional overcurrent, low stage (HV side)	1	1	
Three-phase non-directional overcurrent, high stage (LV side)	1	1	2
Three-phase non-directional overcurrent, high stage (HV side)	1	1	
Three-phase non-directional overcurrent, instantaneous stage (LV side)	1	1	2
Three-phase non-directional overcurrent, instantaneous stage (HV side)	1	1	
Three-phase directional overcurrent, low stage	-	-	2
Three-phase directional overcurrent, high stage	-	-	1
Non-directional earth-fault, low stage (LV side)	-	1	2
Non-directional earth-fault, low stage (HV side)	1	1	
Non-directional earth-fault, high stage (LV side)	-	1	2
Non-directional earth-fault, high stage (HV side)	1	1	
Directional earth-fault, low stage	-	-	2
Directional earth-fault, high stage	-	-	1
Stabilised restricted earth-fault (LV side)	-	1	2
Stabilised restricted earth-fault (HV side)	-	1	
High-impedance-based restricted earth-fault protection	-	-	2
Negative-sequence overcurrent (LV side)	1	1	4
Negative-sequence overcurrent (HV side)	1	1	
Three-phase current inrush detection	-	-	1
Three-phase thermal overload for transformers	1	1	1
Three-phase overvoltage (LV side)	2	2	2
Three-phase undervoltage (LV side)	2	2	2
Positive-sequence overvoltage	-	-	2
Positive-sequence undervoltage	-	-	2
Negative-sequence overvoltage	-	-	2
Residual overvoltage	-	-	3
Frequency gradient	-	-	6
Table continues on next page			

Functionality	A	B	n
Overfrequency	-	-	3
Underfrequency	-	-	3
Overexcitation protection ¹⁾	-	-	2
Three-phase underimpedance protection ¹⁾	-	-	2
Transformer differential protection for two-winding transformers	1	1	1
Circuit-breaker failure (HV side)	1	1	2
Tripping logic (LV side)	1	1	2
Tripping logic (HV side)	1	1	
Multipurpose analog protection	-	-	16
Control			
Bay control	1	1	1
Interlocking interface	4	4	10
Circuit breaker/disconnector control	4	4	10
Circuit breaker	1	1	2
Disconnecter	3	3	8
Local/remote switch interface	-	-	1
Synchrocheck	-	-	1
Tap changer control with voltage regulator ¹⁾	-	-	1
Generic process I/O			
Single point control (8 signals)	-	-	5
Double point indication	-	-	15
Single point indication	-	-	64
Generic measured value	-	-	15
Logic rotating switch for function selection and LHMI presentation	-	-	10
Selector mini switch	-	-	10
Pulse counter for energy metering	-	-	4
Event counter	-	-	1
Supervision and monitoring			
Circuit breaker condition monitoring (HV side)	1	1	2
Fuse failure supervision	1	-	1
Current circuit supervision (LV side)	-	-	2
Current circuit supervision (HV side)	-	-	
Trip-circuit supervision	2	2	3
Tap position indication	-	-	1
Energy monitoring	1	1	1
Station battery supervision	-	-	1
Measured value limit supervision	-	-	40
Measurement			
Table continues on next page			

Functionality	A	B	n
Three-phase current (LV side)	1	1	2
Three-phase current (HV side)	1	1	
Three-phase voltage (phase-to-phase)	1	1	1
Three-phase voltage (phase-to-earth)	1	1	1
Residual current measurement	2	2	2
Residual voltage measurement	-	-	1
Sequence current measurement	-	-	1
Sequence voltage measurement	-	-	1
Power monitoring with P, Q, S, power factor, frequency	1	1	1
Disturbance recorder function			
Analog channels 1-10 (samples)	1	1	1
Analog channels 11-20 (samples)	-	-	1
Analog channels 21-30 (calc. val.)	-	-	1
Analog channels 31-40 (calc. val.)	-	-	1
Binary channels 1-16	1	1	1
Binary channels 17-32	1	1	1
Binary channels 33-48	1	1	1
Binary channels 49-64	1	1	1
Station communication (GOOSE)			
Binary receive	-	-	10
Double point receive	-	-	32
Interlock receive	-	-	59
Integer receive	-	-	32
Measured value receive	-	-	62
Single point receive	-	-	62

1) Optional function, to be specified at ordering

3.2 Preconfiguration A for two-winding HV/MV transformer

3.2.1 Application

The functionality of the IED is designed to be used for three-phase differential, short-circuit, overcurrent, earth-fault, thermal overload and negative-phase sequence, overvoltage and undervoltage protection in power transformer feeders with transformer of type YNd.

The apparatuses controlled by the IED are the high voltage-side circuit breaker and disconnectors. The earth switch is considered to be operated manually. The open,

close and undefined states of the circuit breaker, disconnectors, and earth switch are indicated on the LHMI.

Required interlocking is configured in the IED.

The preconfiguration includes:

- Control functions
- Current protection functions
- Voltage protection functions
- Supervision functions
- Disturbance recorders
- LEDs' configuration
- Measurement functions

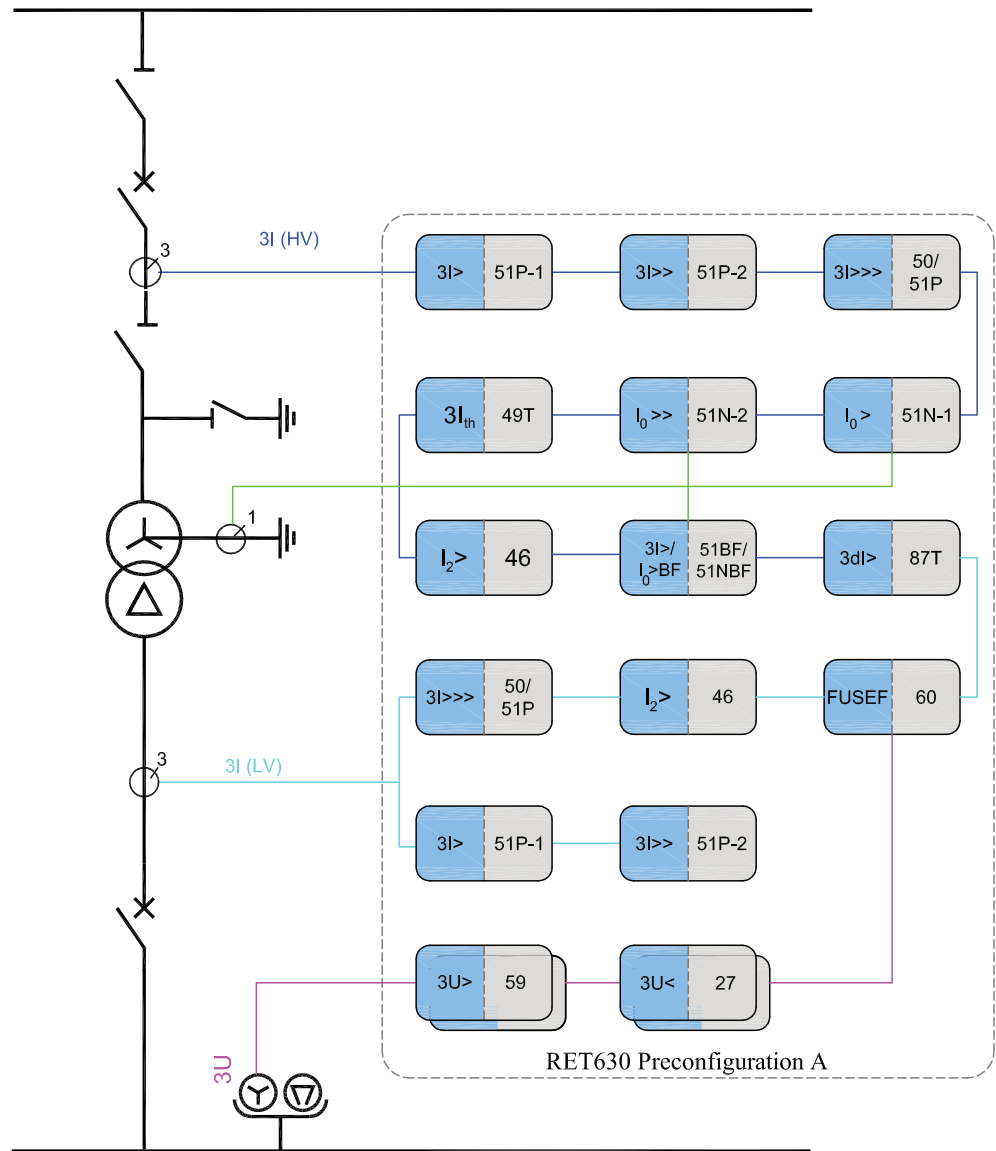

Figure 8: Single-line diagram for preconfiguration A for two-winding HV/MV transformer

3.2.2

Functions

Table 6: Functions included in preconfiguration A for two-winding HV/MV transformer

Functionality	IEC 61850	IEC 60617	ANSI
Protection			
Three-phase non-directional overcurrent, low stage (LV side)	PHLPTOC	3I>	51P-1
Three-phase non-directional overcurrent, low stage (HV side)	PHLPTOC	3I>	51P-1
Table continues on next page			

Functionality	IEC 61850	IEC 60617	ANSI
Three-phase non-directional overcurrent, high stage (LV side)	PHHPTOC	3I>>	51P-2
Three-phase non-directional overcurrent, high stage (HV side)	PHHPTOC	3I>>	51P-2
Three-phase non-directional overcurrent, instantaneous stage (LV side)	PHIPTOC	3I>>>	50P/51P
Three-phase non-directional overcurrent, instantaneous stage (HV side)	PHIPTOC	3I>>>	50P/51P
Non-directional earth-fault, low stage (HV side)	EFLPTOC	I0>	51N-1
Non-directional earth-fault, high stage (HV side)	EFHPTOC	I0>>	51N-2
Negative-sequence overcurrent (LV side)	NSPTOC	I2>	46
Negative-sequence overcurrent (HV side)	NSPTOC	I2>	46
Three-phase thermal overload protection for transformers	T2PTTR	3Ith>T	49T
Transformer differential protection for two-winding transformers	TR2PTDF	3dI>T	87T
Three-phase overvoltage (LV side)	PHPTOV	3U>	59
Three-phase undervoltage (LV side)	PHPTUV	3U<	27
Circuit-breaker failure (HV side)	CCBRBRF	3I>/I0>BF	51BF/51NBF
Tripping logic (LV side)	TRPPTRC	I → O	94
Tripping logic (HV side)	TRPPTRC	I → O	94
Control			
Bay control	QCCBAY	CBAY	CBAY
Interlocking interface	SCILO	3	3
Circuit breaker/disconnector control	GNRLCSWI	I ↔ O CB/DC	I ↔ O CB/DC
Circuit breaker	DAXCBR	I ↔ O CB	I ↔ O CB
Disconnector	DAXSWI	I ↔ O DC	I ↔ O DC
Supervision and monitoring			
Circuit-breaker condition monitoring (HV side)	SSCBR	CBCM	CBCM
Fuse failure supervision	SEQRUFUF	FUSEF	60
Trip-circuit supervision	TCSSCBR	TCS	TCM
Energy monitoring	EPDMMTR	E	E
Measurement			
Three-phase current (LV side)	CMMXU	3I	3I
Three-phase current (HV side)	CMMXU	3I	3I
Three-phase voltage (phase-to-phase)	VPPMMXU	3Upp	3Vpp
Three-phase voltage (phase-to-earth)	VPHMMXU	3Upe	3Vpe
Table continues on next page			

Functionality	IEC 61850	IEC 60617	ANSI
Residual current measurement	RESCMMXU	I0	I0
Power monitoring with P, Q, S, power factor, frequency	PWRMMXU	PQf	PQf
Disturbance recorder function			
Analog channels 1-10 (samples)	A1RADR	ACH1	ACH1
Binary channels 1-16	B1RBDR	BCH1	BCH1
Binary channels 17-32	B2RBDR	BCH2	BCH2
Binary channels 33-48	B3RBDR	BCH3	BCH3
Binary channels 49-64	B4RBDR	BCH4	BCH4

3.2.3 Input/output signal interfaces

Table 7: *Interface of binary inputs*

Hardware module instance	Hardware channel	Description
COM	BI1	Circuit breaker closed
COM	BI2	Circuit breaker open
COM	BI3	Disconnecter 1 closed
COM	BI4	Disconnecter 1 open
COM	BI5	Earth switch closed
COM	BI6	Earth switch open
COM	BI7	Disconnecter 2 closed
COM	BI8	Disconnecter 2 open
COM	BI9	Incoming blocking
COM	BI10	Buchholz alarm
COM	BI11	Buchholz trip
COM	BI12	Pressure relief trip
COM	BI13	Circuit-breaker pressure lockout
COM	BI14	Circuit-breaker spring charged

The outputs of the IED are categorized as power outputs (POx) and signal outputs (SOx). The power outputs can be used for closing and tripping of circuit breakers and disconnecter control. The signal outputs are not heavy-duty outputs. They are used for alarm or signaling purposes.

Table 8: *Interface of binary outputs*

Hardware module instance	Hardware channel	Description
PSM	BO1_PO	High-voltage side circuit breaker trip
PSM	BO2_PO	Low-voltage side circuit breaker trip
PSM	BO3_PO	High-voltage side circuit breaker closed
PSM	BO4_PO	Disconnecter 1 open
Table continues on next page		

Hardware module instance	Hardware channel	Description
PSM	BO5_PO	Disconnecter 1 closed
PSM	BO6_PO	Not connected
PSM	BO7_SO	OC operate alarm
PSM	BO8_SO	EF operate alarm
PSM	BO9_SO	Common start
BIO_3	BO1_PO	Disconnecter 2 open
BIO_3	BO2_PO	Disconnecter 2 closed
BIO_3	BO3_PO	Backup trip
BIO_3	BO4_SO	Differential operate alarm
BIO_3	BO5_SO	Common operate
BIO_3	BO6_SO	External trip
BIO_3	BO7_SO	High-voltage side circuit breaker monitoring alarm
BIO_3	BO8_SO	Supervision circuit alarm
BIO_3	BO9_SO	Not connected

The IED measures the analog signals needed for protection and measuring functions via galvanically isolated matching transformers. The matching transformer input channels 1...7 are intended for current measuring and channels 8...10 for voltage measuring.

Table 9: *Interface of analog input*

Hardware module instance	Hardware channel	Description
AIM_2	CH1	High-voltage side phase current IL1_A
AIM_2	CH2	High-voltage side phase current IL2_A
AIM_2	CH3	High-voltage side phase current IL3_A
AIM_2	CH4	High-voltage side neutral current I ₀ _A
AIM_2	CH5	Low-voltage side phase current IL1_B
AIM_2	CH6	Low-voltage side phase current IL2_B
AIM_2	CH7	Low-voltage side phase current IL3_B
AIM_2	CH8	Low-voltage side phase voltage UL1_B
AIM_2	CH9	Low-voltage side phase voltage UL2_B
AIM_2	CH10	Low-voltage side phase voltage UL3_B

3.2.4

Preprocessing blocks and fixed signals

The analog current and voltage signals coming to the IED are processed by preprocessing blocks. Preprocessing blocks sample the analog values based on 20 samples per cycle. The output from the preprocessing blocks is used by other functions. The preprocessors connected to functions should have the same task time.

A fixed signal block providing a logical TRUE and a logical FALSE output has been used. Outputs are connected internally to other functional blocks when needed.



Even if the *AnalogInputType* setting of a SMAI block is set to “Current”, the *MinValFreqMeas* setting is still visible. This means that the minimum level for current amplitude is based on UBase. As an example, if UBase is 20 kV, the minimum amplitude for current is $20000 \times 10\% = 2000$ A.

3.2.5 Control functions

3.2.5.1 Transformer bay control QCCBAY

Bay control is used to handle the selection of the operator place per bay. It provides blocking functions that can be distributed to different apparatuses within the bay. Bay control sends information about the permitted source to operate (PSTO) and blocking conditions to other functions within the bay, for example switch control functions.

3.2.5.2 Apparatus control SCILO, GNRLCSWI, DAXCBR, DAXSWI

Apparatus control initializes and supervises proper selection and switches on primary apparatus. Each apparatus requires interlocking function, switch control function and apparatus functions.

Circuit-breaker control function

The circuit breaker is controlled by a combination of switch interlocking (SCILO), switch controller (GNRLCSWI) and circuit breaker controller (DAXCBR) functions.

The position information of the circuit breaker is connected to DAXCBR. The interlocking logics for the circuit breaker have been programmed to open at any time, provided that the gas pressure inside the circuit breaker is above the lockout limit. Closing of the circuit breaker is always prevented if the gas pressure inside the circuit breaker is below the lockout limit. In case the disconnectors are closed, it is required that the earth switch is open before the circuit breaker closes.

SCILO function checks for the interlocking conditions and provides closing and opening enable signals. The enable signal is used by GNRLCSWI function block which checks for operator place selector before providing the final open or close signal to DAXCBR function.

The open, closed and undefined states of the circuit breaker are indicated on the LHMI.

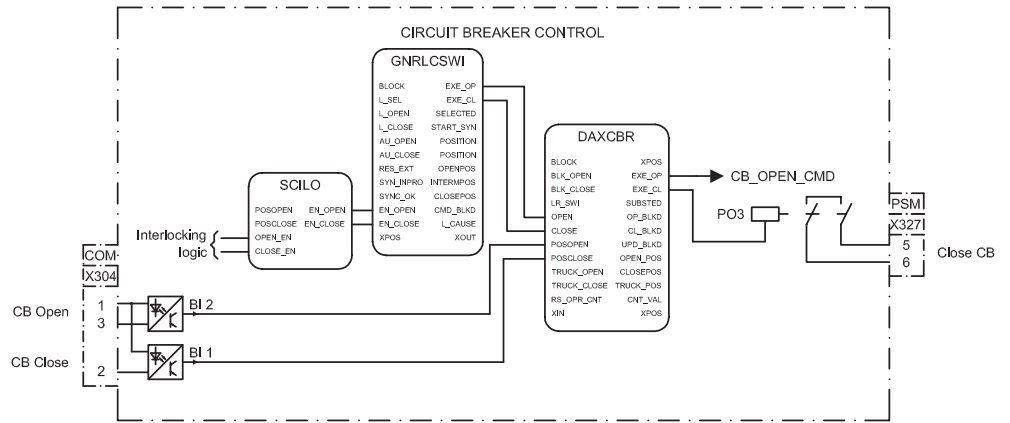

Figure 9: Circuit breaker control

Disconnecter 1, disconnector 2 and earth switch control function

Disconnecter 1, disconnector 2, and earth switch are controlled by a combination of SCILO, GNRLCSWI and DAXSWI functions. Each apparatus requires one set of these functions.

The position information of the disconnectors and the earth switch are connected to respective DAXSWI functions via binary inputs. The interlocking logics for the disconnector 1 have been programmed so that it can be opened or closed only if the circuit breaker is open. Disconnector 2 can be opened or closed only if the circuit breaker and the earth switch are open. The earth switch can be opened or closed if the circuit breaker and disconnector 2 are open.

SCILO function checks for these conditions and provides closing and opening enable signals. The enable signal is used by GNRLCSWI function blocks which check for the operator place selector before providing the final open or close signal to DAXCBBR function.

The open, closed and undefined states of the disconnector 1, disconnector 2 and earth switch are indicated on the LHMI.

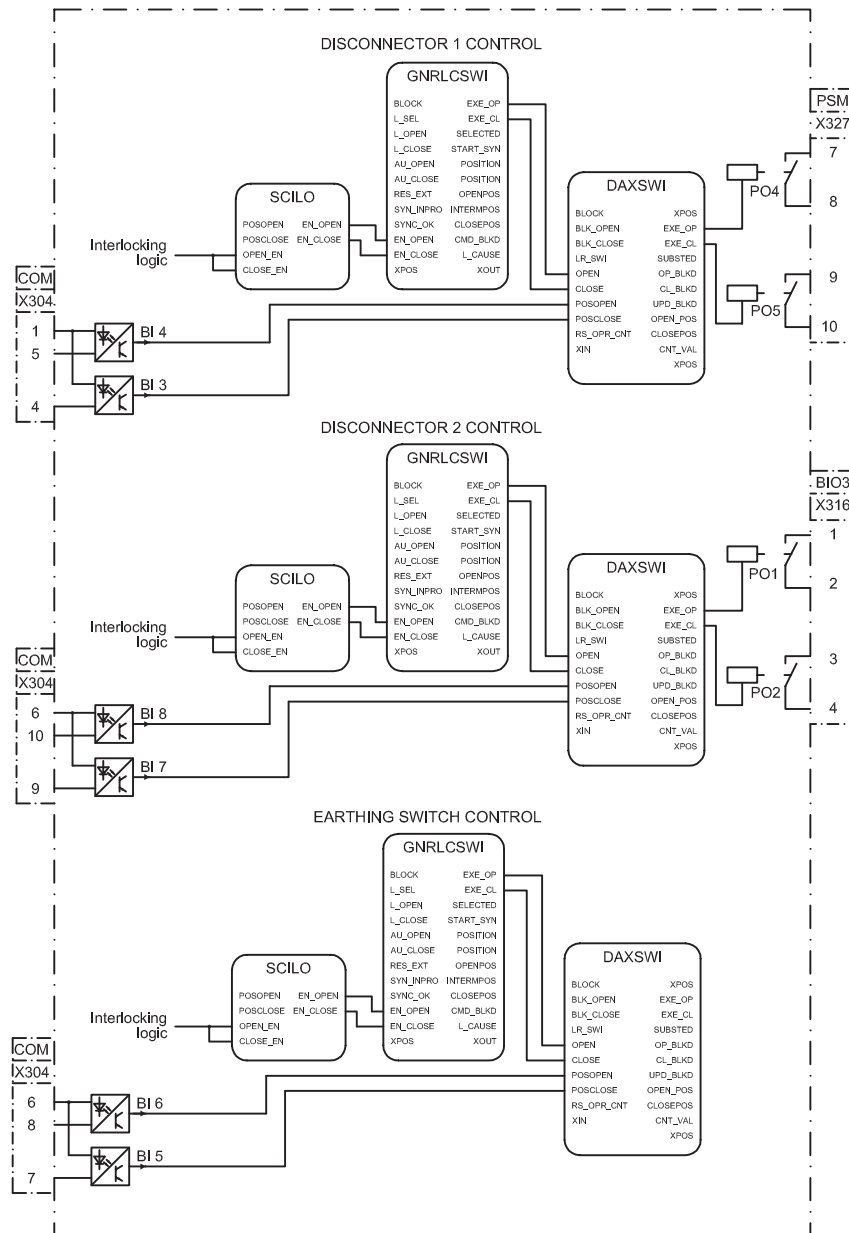

Figure 10: Disconnector control

3.2.6 Protection functions

3.2.6.1 Differential protection for two-winding transformer TR2PTDF

The three-phase current differential protection with low stage (biased stage) and high stage (instantaneous stage) is used for providing winding short-circuit and interturn protection for two-winding transformer.

Function provides internal blocking for the biased stage

- Based on the ratio of second harmonic preventing unwanted operations at transformer inrush currents.
- Based on the ratio of fifth harmonic preventing operation in harmless situations of transformer overexcitation.
- Based on waveform.

Harmonic blocking outputs from the second harmonic and waveform are connected to an OR-gate to form inrush blocking signal which can be used for multiplying start values of the overcurrent and earth fault protection on the high-voltage side. The default multiplier setting in overcurrent and earth fault functions is 1.0.

The operate signal from the low and high stages are used to provide a LED indication on the LHMI. Low stage and high stage operate outputs, along with second harmonic and wave harmonic inrush blocking signals, are connected to the disturbance recorder.

3.2.6.2

Non-directional overcurrent protection PHxPTOC

The three-phase non-directional overcurrent functions are used for non-directional one-phase, two-phase and three-phase overcurrent and short-circuit protection with definite time or various inverse definite minimum time (IDMT) characteristic. The operation of a stage is based on three measuring principles: DFT, RMS or peak-to-peak values.

The preconfiguration includes low, high and instantaneous stages of non-directional overcurrent functions both for the high-voltage and the low-voltage side. The set of three phase currents, I3P, is connected to the inputs. The inrush detected by the differential protection function can increase the start value of instantaneous stage overcurrent function on the high-voltage side protection.

A common operate and start signal from three non-directional overcurrent functions from the high-voltage side are connected to an OR-gate to form a combined non-directional high-voltage side overcurrent operate and start signal which is used to provide a LED indication on the LHMI. Similarly a common operate and start signal from three non-directional overcurrent functions from the low-voltage side are connected to an OR-gate to form a combined non-directional low-voltage side overcurrent operate and start signal which is also used for providing a LED indication on the LHMI. Also separate start and operate signals from all the six OC functions are connected to the disturbance recorder.

Instantaneous overcurrent function block of low-voltage side can be blocked by an incoming signal available at binary input COM BI9. Similarly, the high-stage overcurrent function block of high-voltage side can be blocked by an incoming signal COM BI9 or from the START of the high-stage low-voltage side overcurrent protection.

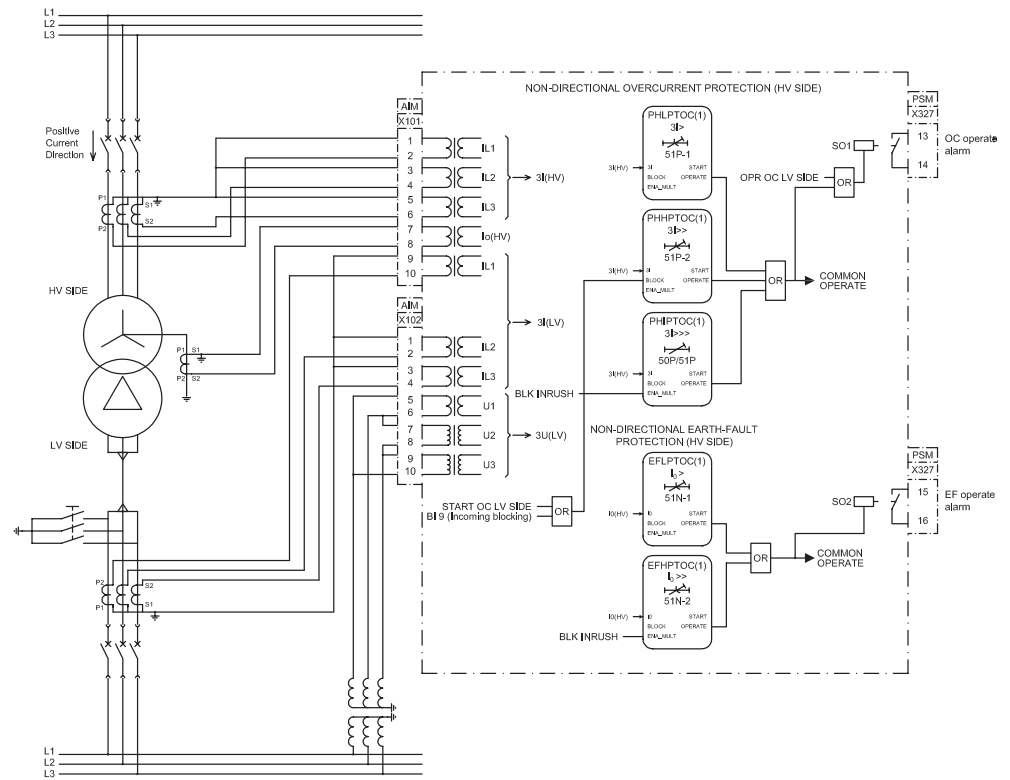

Figure 11: Non-directional overcurrent protection

3.2.6.3

Negative-sequence overcurrent protection NSPTOC

Two instances of negative-sequence overcurrent detection are provided, one for high-voltage side and another for low-voltage side, for protection against single-phasing, unbalanced load or asymmetrical voltage. The set of three phase currents, I3P, is connected to the inputs.

A common operate and start signal from both NSPTOC functions are connected to an OR-gate to form a combined negative-sequence overcurrent operate and start signal which is used to provide a LED indication on the LHMI. Also separate start and operate signals from the NSPTOC function is connected to the disturbance recorder.

3.2.6.4

Non-directional earth-fault protection EFXPTOC

The non-directional earth-fault protection functions are used for protection under earth-fault conditions with definite-time (DT) or with inverse definite minimum time (IDMT) characteristic when appropriate.

The operation of the stage is based on three measuring principles: DFT, RMS or peak-to-peak values. The configuration includes high and low stage non-directional earth-fault function blocks for high-voltage side of the transformer. Transformer neutral current from the high-voltage side is connected to the input. The inrush detected by

the differential protection function can increase the start value of instantaneous earth-fault function.

A common operate and start signal from the high-stage and low-stage earth-fault protection functions are connected to an OR-gate to form a combined non-directional earth-fault operate and start signal which is used to provide a LED indication on the LHMI. Also separate start and operate signals from all of these functions are connected to the disturbance recorder.

3.2.6.5

Thermal overload protection T2PTTR

The three-phase thermal overload protection function is used for thermal protection of the power transformers. It has adjustable temperature limits for tripping, alarm and reclose inhibit. The thermal model applied uses two time constants and the true RMS current measuring principle. Reclose inhibit is programmed to block the circuit breaker in case the thermal values are above inhibit levels.

The operate signal from the thermal overload protection is further used to trigger the disturbance recorder. Both operate and alarm signals provide a LED indication on the LHMI.



The operate signal from the thermal overload protection is normally used for tripping of the low-voltage side breaker only.

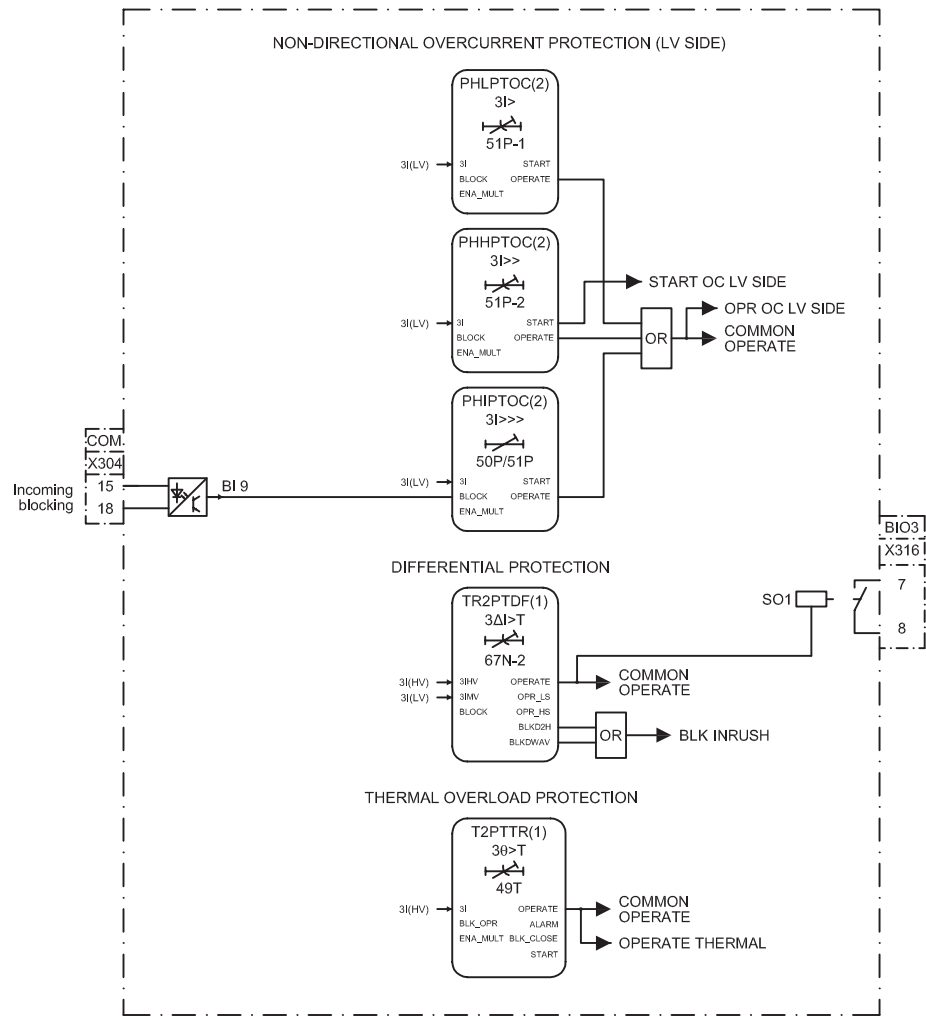

Figure 12: Thermal overload protection

3.2.6.6

Three-phase overvoltage protection PHPTOV

The three-phase overvoltage protection function is designed to be used for one-phase, two-phase and three-phase phase-to-earth or phase-to-phase overvoltage protection with definite time or various inverse definite minimum time (IDMT) characteristic.

The preconfiguration includes two instances of phase overvoltage function blocks for protection on low-voltage side. The set of three phase voltages, U3P, is connected to the inputs. The preconfiguration is build on a HW variant with three voltage inputs where you can use either phase-to-earth or phase-to-phase voltages.

A common operate and start signal from both overvoltage functions of low-voltage side are connected to an OR-gate to form a combined low-voltage side overvoltage operate and start signal which is used to provide a LED indication on the LHMI.

Also separate start and operate signals from both instances are connected to the disturbance recorder.

3.2.6.7

Three-phase undervoltage protection PHPTUV

The three-phase undervoltage protection function is designed to be used for one-phase, two-phase and three-phase phase-to-earth or phase-to-phase overvoltage protection with definite time or various inverse definite minimum time (IDMT) characteristic.

The configuration includes two instances of phase undervoltage function blocks for protection on low-voltage side. The set of three phase voltages, U3P, is connected to the inputs. The preconfiguration is build on a HW variant with two voltage inputs where you can use either phase-to-earth or phase-to-phase voltages.

A common operate and start signal from both undervoltage protection functions of low-voltage side are connected to an OR-gate to form a combined low-voltage side undervoltage operate and start signal which is used to provide a LED indication on the LHMI. Also separate start and operate signals from both instances are connected to the disturbance recorder. Both undervoltage functions can be blocked by fuse failure supervision.

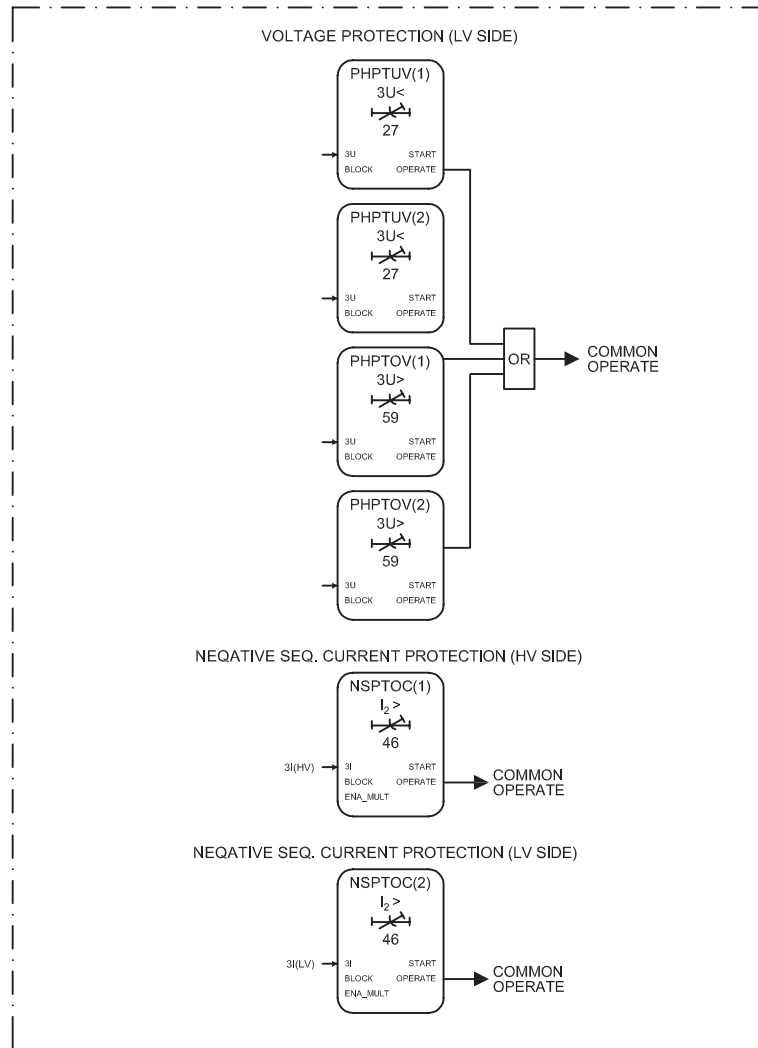

Figure 13: Three-phase undervoltage protection

3.2.6.8

Circuit-breaker failure protection CCBRBRF

The function is activated by the common operate command from the protection functions. The breaker failure function issues a backup trip command to adjacent circuit breakers in case the main circuit breaker fails to trip for the protected component. The backup trip is connected at binary output BIO_3 PO3.

A failure of a circuit breaker is detected by measuring the current or by detecting the remaining trip signal. Function also provides retrip. Retrip is used along with the main trip, and is activated before the backup trip signal is generated in case the main breaker fails to open. Retrip is used to increase the operational reliability of the circuit breaker.

3.2.6.9 Tripping logic TRPPTRC

Two tripping circuits, one for high-voltage side and other for low-voltage side breaker, have been configured to provide tripping signal of required duration. The tripping circuit opens the high-voltage side circuit breaker on

- Receipt of operate signal from the protection function or
- Retrip signal from the circuit-breaker failure protection.

The circuit breaker of the low-voltage side is open on receipt of operate signal from the protection function or retrip signal. Master tripping signals for high-voltage and low-voltage circuit breaker are available at binary output PSM PO1 and PSM PO2 respectively.

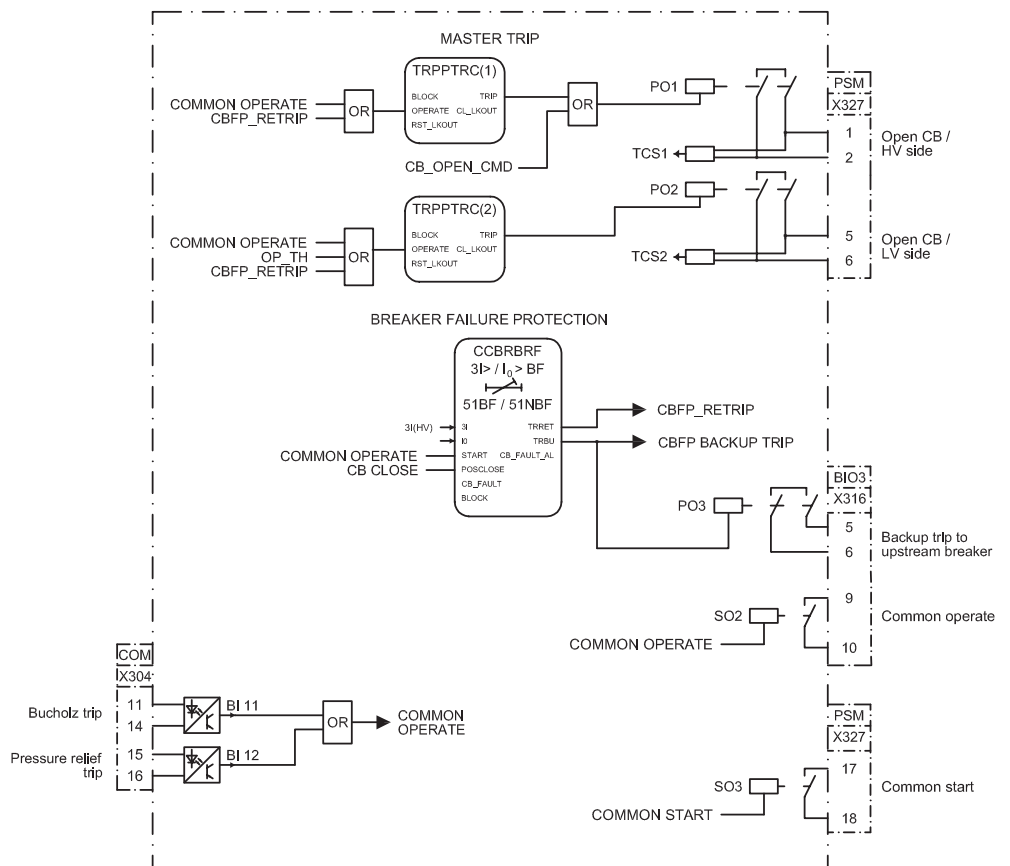

Figure 14: Tripping logic

3.2.6.10 Combined operate and start alarm signal

The operate outputs of all protection functions are combined in an OR-gate to get a common Operate output. This common operate signal is connected to a tripping logic. It is also available as an alarm binary output, BIO_3_SO2, with a settable minimum alarm delay of 80 ms. Also, a common Start output is derived from the

start outputs of protection functions combined in an OR-gate. The output is available as an alarm binary output PSM SO3 with a settable minimum alarm delay of 80 ms.

3.2.6.11 Other output and alarm signals

- Combined high-voltage and low-voltage side overcurrent operate available at binary output PSM SO1
- Earth-fault operate alarm available at binary output PSM SO2
- Differential operate alarm available at binary output BIO_3 SO1
- Combined external Buchholz and pressure relief trip available at binary output BIO_3 SO3
- Combined alarm from high-voltage side circuit-breaker monitoring function available at binary output BIO_3 SO4
- Combined alarm from various supervision functions available at binary output BIO_3 SO5

3.2.7 Supervision functions

3.2.7.1 Trip circuit supervision TCSSCBR

One instance of trip circuit supervision function is used for supervising the tripping circuit of the high-voltage side circuit breaker. Function continuously supervises the trip circuit and an alarm is issued in case of a failure of a trip circuit. The function block does not perform the supervision itself but it is used as an aid for configuration. The function is blocked when any protection function operate signal is active or the high-voltage side circuit breaker is open to prevent unwanted alarms.

The other instance of trip circuit supervision is used to check the proper functioning of the closing circuit of high-voltage side circuit breaker. The function is blocked when circuit breaker is in closed position to prevent unwanted alarms. Alarms from the both instances are separately connected to the binary recorder.

3.2.7.2 Fuse failure supervision SEQRFUF

The fuse failure supervision functions give an alarm in case of a failure in the secondary circuits between the voltage transformer and the IED. The set of three phase currents and voltages, I3P and U3P, are connected to the inputs. The configuration has been programmed to give fuse failure in case of failure on the low-voltage side of the transformer.

An alarm is available on detection of fuse failure. The alarm is recorded by a disturbance recorder.

3.2.7.3 Circuit-breaker condition monitoring SSCBR

The circuit-breaker condition monitoring function checks for the health of the high-voltage side circuit breaker. The circuit breaker status is connected to the function via binary inputs. Function requires also pressure lockout input and spring charged input connected via binary input COM_101.BI13 and COM_101.BI14 respectively. Various alarm outputs from the function are combined in an OR-gate to create a master circuit-breaker monitoring alarm, which is available at binary output BIO_3 SO4.

All of the alarms are separately connected to the binary recorder and a combined alarm is available as an indication via a LED on the LHMI.

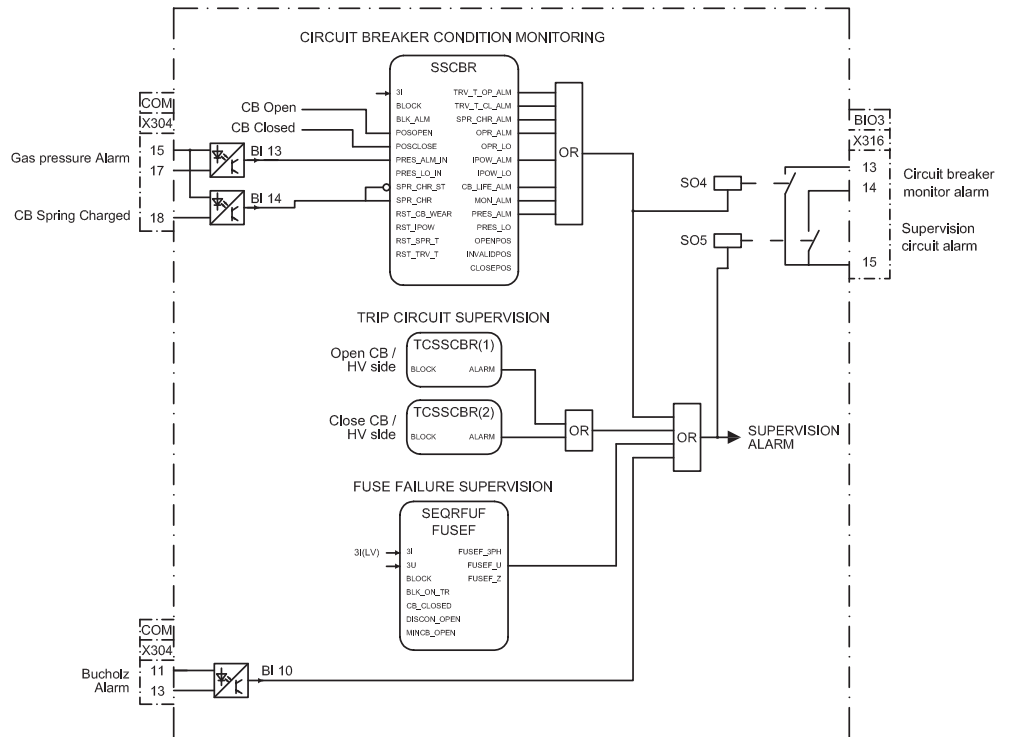

Figure 15: Circuit-breaker condition monitoring

3.2.8 Measurement and analog recording functions

The measured quantities in this configuration are:

- Phase current measurements
 - Winding 1
 - Winding 2
- Residual current measurements

- Winding 1
- Winding 2
- Differential and bias currents
- Phase voltage measurements
- Phase-to-phase voltage measurements

The measured quantities can be viewed in the measurement menu on the LHMI.

All analog input channels are connected to the analog disturbance recorder. When any of these analog values violate the upper or lower threshold limits, the recorder unit is triggered which in turn will record all the signals connected to the recorder.

Table 10: *Signals connected to the analog recorder*

Channel ID	Description
Channel 1	High-voltage side phase A current
Channel 2	High-voltage side phase B current
Channel 3	High-voltage side phase C current
Channel 4	High-voltage side neutral current
Channel 5	Low-voltage side phase A current
Channel 6	Low-voltage side phase B current
Channel 7	Low-voltage side phase C current
Channel 8	Low-voltage side phase A voltage
Channel 9	Low-voltage side phase B voltage
Channel 10	Low-voltage side phase C voltage



Data connected to analog channels contain 20 samples per cycle.

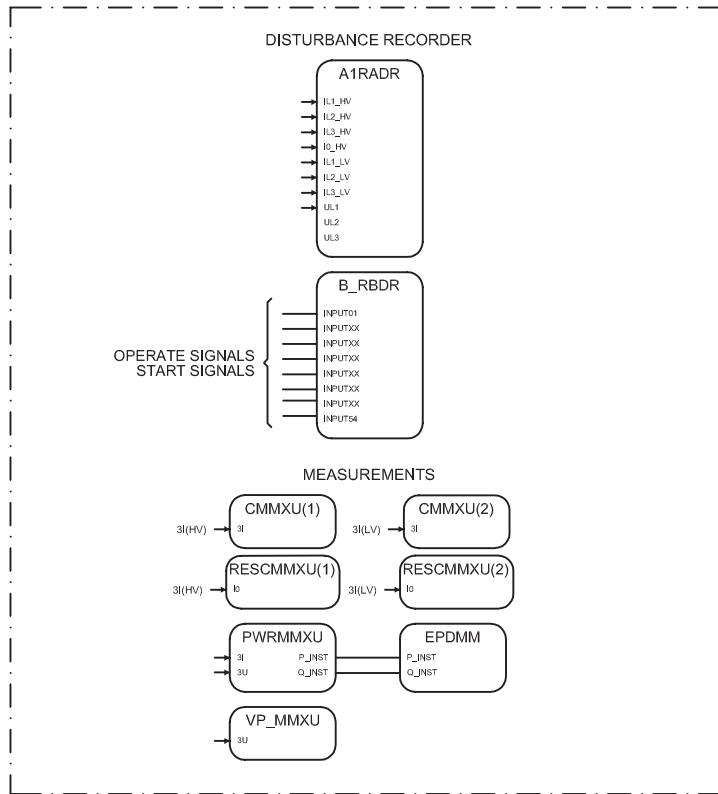

Figure 16: Measurement and analog recording

3.2.9

Binary recording and LED configuration

All of the start and operate outputs from the respective protection functions, various alarms from supervision functions, and important signals from control and protective functions are connected to a binary recorder. In case of a fault, the binary recorder is triggered which in turn will record all the signals connected to the recorder.

Table 11: Signal connected to the binary recorder

Channel ID	Description
Channel 1	Start of high-voltage side overcurrent high stage
Channel 2	Operate of high-voltage side overcurrent high stage
Channel 3	Start of high-voltage side overcurrent instantaneous stage
Channel 4	Operate of high-voltage side overcurrent instantaneous stage
Channel 5	Start of high-voltage side overcurrent low stage
Channel 6	Operate of high-voltage side overcurrent low stage
Channel 7	Start of low-voltage side overcurrent high stage
Channel 8	Operate of low-voltage side overcurrent high stage
Channel 9	Start of low-voltage side overcurrent instantaneous stage

Table continues on next page

Channel ID	Description
Channel 10	Operate of low-voltage side overcurrent instantaneous stage
Channel 11	Start of low-voltage side overcurrent low stage
Channel 12	Operate of low-voltage side overcurrent low stage
Channel 13	Start of high-voltage side earth fault high stage
Channel 14	Operate of high-voltage side earth fault high stage
Channel 15	Start of high-voltage side earth fault low stage
Channel 16	Operate of high-voltage side earth fault low stage
Channel 17	Start of high-voltage side negative-sequence overcurrent
Channel 18	Operate of high-voltage side negative-sequence overcurrent
Channel 19	Start of low-voltage side negative-sequence overcurrent
Channel 20	Operate of low-voltage side negative-sequence overcurrent
Channel 21	Operate of thermal overload
Channel 22	Operate of differential protection high stage
Channel 23	Operate of differential protection low stage
Channel 24	Start of low-voltage side overvoltage stage 1
Channel 25	Operate of low-voltage side overvoltage stage 1
Channel 26	Start of low-voltage side overvoltage stage 2
Channel 27	Operate of low-voltage side overvoltage stage 2
Channel 28	Start of low-voltage side undervoltage stage 1
Channel 29	Operate of low-voltage side undervoltage stage 1
Channel 30	Start of low-voltage side undervoltage stage 2
Channel 31	Operate of low-voltage side undervoltage stage 2
Channel 32	Blocked by second harmonic from differential protection
Channel 33	Waveform blocking from differential protection
Channel 34	Blocked by thermal overload protection
Channel 35	Circuit breaker closed
Channel 36	Circuit breaker is open
Channel 37	Backup trip from circuit-breaker failure protection
Channel 38	Retrip from circuit-breaker failure protection
Channel 39	Trip circuit alarm 1 (supervising high-voltage breaker trip)
Channel 40	Trip circuit alarm 2 (supervising high-voltage breaker-closing circuit)
Channel 41	Accumulated current power exceeds set limit
Channel 42	Circuit breaker not operated since long
Channel 43	Closing time of circuit breaker exceeded the limit
Channel 44	Opening time of circuit breaker exceeded the limit
Channel 45	Pressure in circuit breaker below lockout limit
Channel 46	Spring charge time of circuit breaker exceeded the limit
Channel 47	Number of circuit breaker operation exceeded the set limit
Channel 48	Circuit breaker life alarm

Table continues on next page

Channel ID	Description
Channel 49	Low-voltage side fuse failure
Channel 50	External blocking signal
Channel 51	Buchholz alarm
Channel 52	Buchholz trip
Channel 53	Pressure relief trip

The LEDs are configured for alarm indications.

Table 12: *LEDs configured on LHMI alarm page 1*

LED No	LED color	Description
LED 1	Red	Operate from low stage differential protection
LED 2	Red	Operate from high stage differential protection
LED 3	Yellow	Combine start from high-voltage side OC protection
LED 3	Red	Combine operate from high-voltage side OC protection
LED 4	Yellow	Combine start from low-voltage side OC protection
LED 4	Red	Combine operate from low-voltage side OC protection
LED 5	Yellow	Combine start from EF
LED 5	Red	Combine operate from EF
LED 6	Yellow	Alarm from thermal overload
LED 6	Red	Operate from thermal overload
LED 7	Yellow	Combine start from NSOC
LED 7	Red	Combine operate from NSOC
LED 8	Yellow	Combine start from low-voltage side overvoltage protection
LED 8	Red	Combine operate from low-voltage side overvoltage protection
LED 9	Yellow	Combine start from low-voltage side undervoltage protection
LED 9	Red	Combine operate from low-voltage side undervoltage protection
LED 10	Yellow	Backup trip from circuit-breaker protection function
LED 10	Red	Retrip from circuit-breaker protection function
LED 11	Red	Supervision alarms
LED 12	Red	External trip
LED 13	Red	Alarm from circuit-breaker monitoring function

3.3 Preconfiguration B for two-winding HV/MV transformer, including numerical REF protection

3.3.1 Application

The functionality of the IED is designed to be used for three-phase differential, short-circuit, overcurrent, earth-fault, thermal overload and negative-phase sequence, overvoltage and undervoltage protection in power transformer feeders with transformer of type YNyn.

The apparatuses controlled by the IED are the high voltage-side circuit breaker and disconnectors. The earth switch is considered to be operated manually. The open, close and undefined states of the circuit breaker, disconnectors, and earth switch are indicated on the LHMI.

Required interlocking is configured in the IED.

The preconfiguration includes:

- Control functions
- Current protection functions
- Voltage protection functions
- Supervision functions
- Disturbance recorders
- LEDs' configuration
- Measurement functions

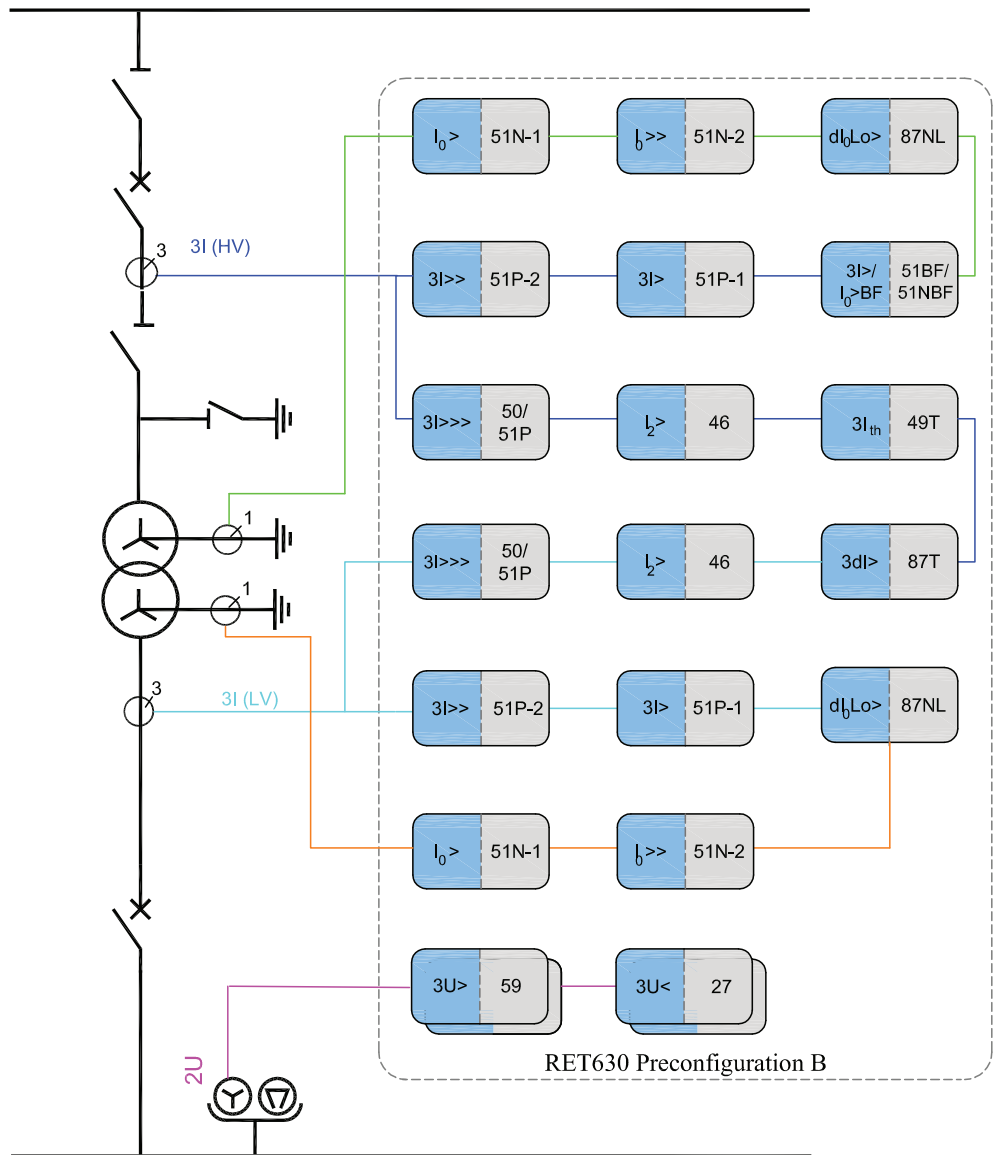

Figure 17: Single-line diagram for preconfiguration B for two-winding HV/MV transformer, including numerical REF protection

3.3.2

Functions

Table 13: Functions included in preconfiguration B for two-winding HV/MV transformer, including numerical REF protection

Functionality	IEC 61850	IEC 60617	ANSI
Protection			
Three-phase non-directional overcurrent, low stage (LV side)	PHLPTOC	3I>	51P-1
Three-phase non-directional overcurrent, low stage (HV side)	PHLPTOC	3I>	51P-1
Table continues on next page			

Functionality	IEC 61850	IEC 60617	ANSI
Three-phase non-directional overcurrent, high stage (LV side)	PHHPTOC	3I>>	51P-2
Three-phase non-directional overcurrent, high stage (HV side)	PHHPTOC	3I>>	51P-2
Three-phase non-directional overcurrent, instantaneous stage (LV side)	PHIPTOC	3I>>>	50P/51P
Three-phase non-directional overcurrent, instantaneous stage (HV side)	PHIPTOC	3I>>>	50P/51P
Non-directional earth-fault, low stage (LV side)	EFLPTOC	I0>	51N-1
Non-directional earth-fault, low stage (HV side)	EFLPTOC	I0>	51N-1
Non-directional earth-fault, high stage (LV side)	EFHPTOC	I0>>	51N-2
Non-directional earth-fault, high stage (HV side)	EFHPTOC	I0>>	51N-2
Stabilised restricted earth-fault (LV side)	LREFPNDF	dI0Lo>	87NL
Stabilised restricted earth-fault (HV side)	LREFPNDF	dI0Lo>	87NL
Negative-sequence overcurrent (LV side)	NSPTOC	I2>	46
Negative-sequence overcurrent (HV side)	NSPTOC	I2>	46
Three-phase thermal overload protection for transformers	T2PTTR	3Ith>T	49T
Transformer differential protection for two winding transformers	TR2PTDF	3dI>T	87T
Three-phase overvoltage (LV side)	PHPTOV	3U>	59
Three-phase undervoltage (LV side)	PHPTUV	3U<	27
Circuit-breaker failure (HV side)	CCBRBRF	3I>/I0>BF	51BF/51NBF
Tripping logic (LV side)	TRPPTRC	I → O	94
Tripping logic (HV side)	TRPPTRC	I → O	94
Control			
Bay control	QCCBAY	CBAY	CBAY
Interlocking interface	SCILO	3	3
Circuit breaker/disconnector control	GNRLCSWI	I ↔ O CB/DC	I ↔ O CB/DC
Circuit breaker	DAXCBR	I ↔ O CB	I ↔ O CB
Disconnector	DAXSWI	I ↔ O DC	I ↔ O DC
Supervision and monitoring			
Circuit-breaker condition monitoring (HV side)	SSCBR	CBCM	CBCM
Trip-circuit supervision	TCSSCBR	TCS	TCM
Energy monitoring	EPDMMTR	E	E
Table continues on next page			

Functionality	IEC 61850	IEC 60617	ANSI
Measurement			
Three-phase current (LV side)	CMMXU	3I	3I
Three-phase current (HV side)	CMMXU	3I	3I
Three-phase voltage (phase-to-phase)	VPPMMXU	3Upp	3Vpp
Three-phase voltage (phase-to-earth)	VPHMMXU	3Upe	3Vpe
Residual current measurement	RESCMMXU	I0	I0
Power monitoring with P, Q, S, power factor, frequency	PWRMMXU	PQf	PQf
Disturbance recorder function			
Analog channels 1-10 (samples)	A1RADR	ACH1	ACH1
Binary channels 1-16	B1RBDR	BCH1	BCH1
Binary channels 17-32	B2RBDR	BCH2	BCH2
Binary channels 33-48	B3RBDR	BCH3	BCH3
Binary channels 49-64	B4RBDR	BCH4	BCH4

3.3.3

Input/output signal interfaces

Table 14: *Interface of binary inputs*

Hardware module instance	Hardware channel	Description
COM	B11	Circuit breaker closed
COM	B12	Circuit breaker open
COM	B13	Disconnecter 1 closed
COM	B14	Disconnecter 1 open
COM	B15	Earth switch closed
COM	B16	Earth switch open
COM	B17	Disconnecter 2 closed
COM	B18	Disconnecter 2 open
COM	B19	Incoming blocking
COM	B110	Buchholz alarm
COM	B111	Buchholz trip
COM	B112	Pressure relief trip
COM	B113	Circuit-breaker pressure lockout
COM	B114	Circuit-breaker spring charged

The outputs of the IED are categorized as power outputs (POx) and signal outputs (SOx). The power outputs can be used for closing and tripping of circuit breakers and disconnecter control. The signal outputs are not heavy-duty outputs. They are used for alarm or signaling purposes.

Table 15: *Interface of binary outputs*

Hardware module instance	Hardware channel	Description
PSM	BO1_PO	High-voltage side circuit breaker trip
PSM	BO2_PO	Low-voltage side circuit breaker trip
PSM	BO3_PO	High-voltage side circuit breaker closed
PSM	BO4_PO	Disconnecter 1 open
PSM	BO5_PO	Disconnecter 1 closed
PSM	BO6_PO	Not connected
PSM	BO7_SO	OC operate alarm
PSM	BO8_SO	EF/LREF operate alarm
PSM	BO9_SO	Common start
BIO_3	BO1_PO	Disconnecter 2 open
BIO_3	BO2_PO	Disconnecter 2 closed
BIO_3	BO3_PO	Backup trip
BIO_3	BO4_SO	Differential operate alarm
BIO_3	BO5_SO	Common operate
BIO_3	BO6_SO	External trip
BIO_3	BO7_SO	High-voltage side circuit breaker monitoring alarm
BIO_3	BO8_SO	Supervision circuit alarm
BIO_3	BO9_SO	Not connected

The IED measures the analog signals needed for protection and measuring functions via galvanically isolated matching transformers. The matching transformer input channels 1...8 are intended for current measuring and channels 9...10 for voltage measuring.

Table 16: *Interface of analog inputs*

Hardware module instance	Hardware channel	Description
AIM_2	CH1	High-voltage side phase current IL1_A
AIM_2	CH2	High-voltage side phase current IL2_A
AIM_2	CH3	High-voltage side phase current IL3_A
AIM_2	CH4	High-voltage side neutral current I ₀ _A
AIM_2	CH5	Low-voltage side phase current IL1_B
AIM_2	CH6	Low-voltage side phase current IL2_B
AIM_2	CH7	Low-voltage side phase current IL3_B
AIM_2	CH8	Low-voltage side neutral current I ₀ _B
AIM_2	CH9	Low-voltage side phase voltage UL1_B
AIM_2	CH10	Low-voltage side phase voltage UL2_B

3.3.4 Preprocessing blocks and fixed signals

The analog current and voltage signals coming to the IED are processed by preprocessing blocks. Preprocessing blocks sample the analog values based on 20 samples per cycle. The output from the preprocessing blocks is used by other functions. The preprocessors connected to functions should have the same task time.

A fixed signal block providing a logical TRUE and a logical FALSE output has been used. Outputs are connected internally to other functional blocks when needed.



Even if the *AnalogInputType* setting of a SMAI block is set to “Current”, the *MinValFreqMeas* setting is still visible. This means that the minimum level for current amplitude is based on UBase. As an example, if UBase is 20 kV, the minimum amplitude for current is $20000 \times 10\% = 2000 \text{ A}$.

3.3.5 Control functions

3.3.5.1 Transformer bay control QCCBAY

Bay control is used to handle the selection of the operator place per bay. It provides blocking functions that can be distributed to different apparatuses within the bay. Bay control sends information about the permitted source to operate (PSTO) and blocking conditions to other functions within the bay, for example switch control functions.

3.3.5.2 Apparatus control SCILO, GNRLCSWI, DAXCBR, DAXSWI

Apparatus control initializes and supervises proper selection and switches on primary apparatus. Each apparatus requires interlocking function, switch control function and apparatus functions.

Circuit-breaker control function

The circuit breaker is controlled by a combination of switch interlocking (SCILO), switch controller (GNRLCSWI) and circuit breaker controller (DAXCBR) functions.

The position information of the circuit breaker is connected to DAXCBR. The interlocking logics for the circuit breaker have been programmed to open at any time, provided that the gas pressure inside the circuit breaker is above the lockout limit. Closing of the circuit breaker is always prevented if the gas pressure inside the circuit breaker is below the lockout limit. In case the disconnectors are closed, it is required that the earth switch is open before the circuit breaker closes.

SCILO function checks for the interlocking conditions and provides closing and opening enable signals. The enable signal is used by GNRLCSWI function block

which checks for operator place selector before providing the final open or close signal to DAXCBR function.

The open, closed and undefined states of the circuit breaker are indicated on the LHMI.

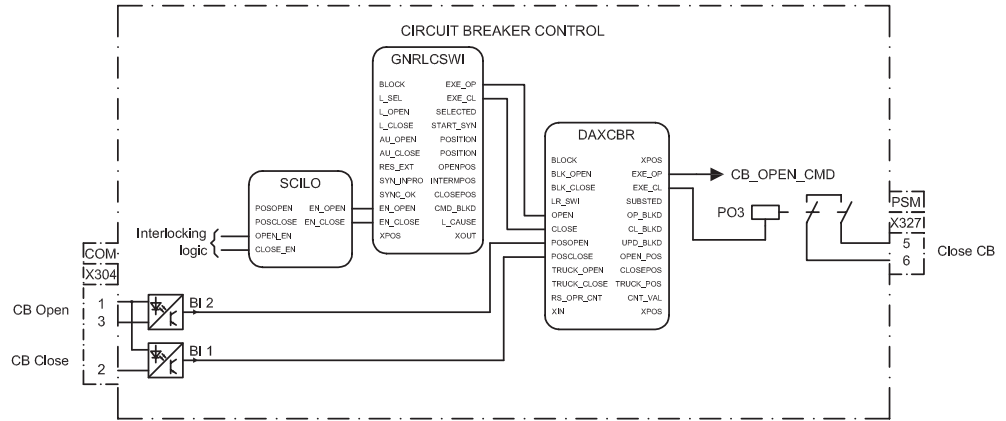

Figure 18: Circuit breaker control

Disconnecter 1, disconnector 2 and earth switch control function

Disconnecter 1, disconnector 2, and earth switch are controlled by a combination of SCILO, GNRLCSWI and DAXSWI functions. Each apparatus requires one set of these functions.

The position information of the disconnectors and the earth switch are connected to respective DAXSWI functions via binary inputs. The interlocking logics for the disconnector 1 have been programmed so that it can be opened or closed only if the circuit breaker is open. Disconnecter 2 can be opened or closed only if the circuit breaker and the earth switch are open. The earth switch can be opened or closed if the circuit breaker and disconnector 2 are open.

SCILO function checks for these conditions and provides closing and opening enable signals. The enable signal is used by GNRLCSWI function blocks which check for the operator place selector before providing the final open or close signal to DAXCBR function.

The open, closed and undefined states of the disconnector 1, disconnector 2 and earth switch are indicated on the LHMI.

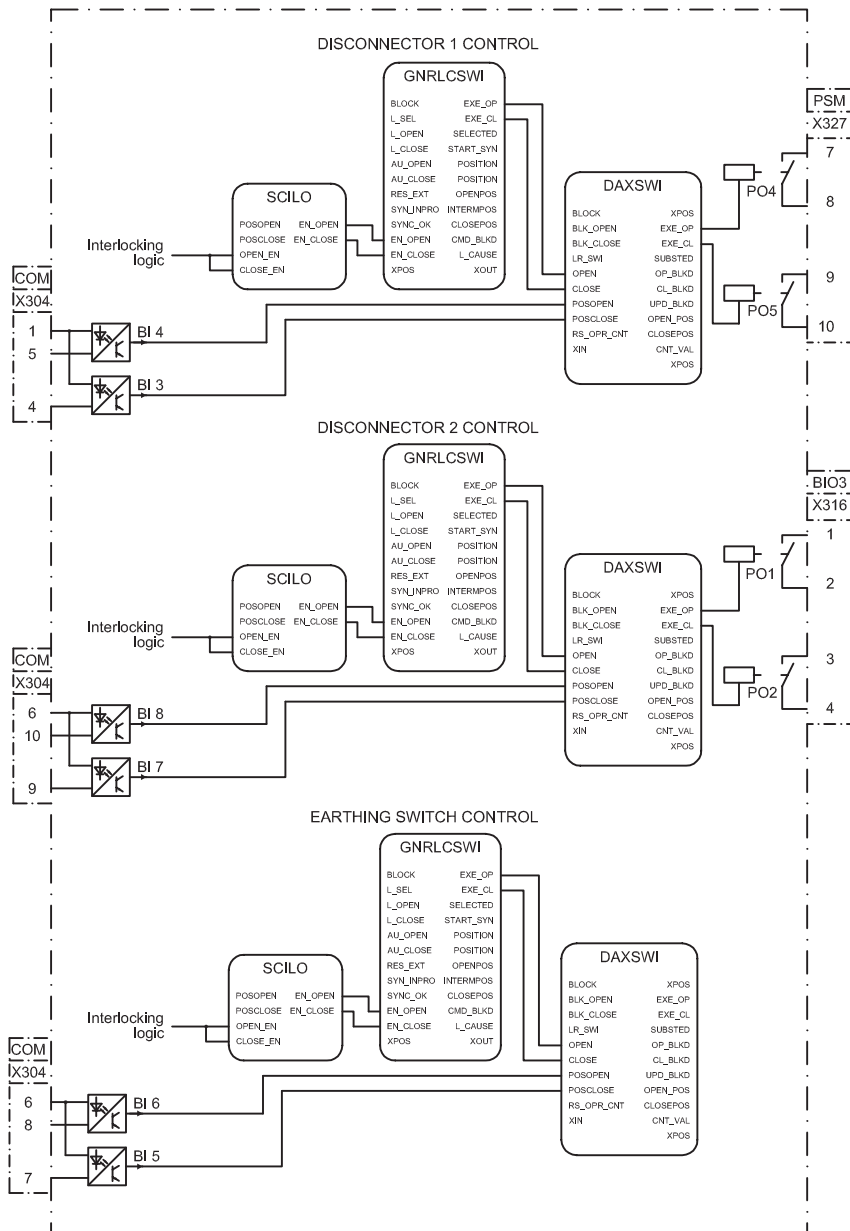

Figure 19: Disconnector control

3.3.6 Protection functions

3.3.6.1 Differential protection for two-winding transformer TR2PTDF

The three-phase current differential protection with low stage (biased stage) and high stage (instantaneous stage) is used for providing winding short-circuit and interturn protection for two-winding transformer.

Function provides internal blocking for the biased stage

- Based on the ratio of second harmonic preventing unwanted operations at transformer inrush currents.
- Based on the ratio of fifth harmonic preventing operation in harmless situations of transformer overexcitation.
- Based on waveform.

Harmonic blocking outputs from the second harmonic and waveform are connected to an OR-gate to form inrush blocking signal which can be used for multiplying start values of the overcurrent and earth fault protection on the high-voltage side. The default multiplier setting in overcurrent and earth fault functions is 1.0.

The operate signal from the low and high stages are used to provide a LED indication on the LHMI. Low stage and high stage operate outputs, along with second harmonic and wave harmonic inrush blocking signals, are connected to the disturbance recorder.

3.3.6.2

Stabilized restricted earth-fault protection LREFPNDF

Stabilized restricted low-impedance earth-fault protection for two-winding transformer is based on the numerical stabilized differential current principle, with definite time characteristics. No external stabilizing resistor or nonlinear resistor is needed.

The configuration includes two instances of the function, one for high-voltage side and other for low-voltage side. A set of currents, I3P, is connected to the inputs.

A common operate and start signal from the stabilized restricted low-impedance earth-fault protection are connected to an OR-gate to form a combined stabilized restricted low-impedance earth-fault operate and start signal which is used to provide a LED indication on the LHMI. Also separate start and operate outputs from both instances are connected to the disturbance recorder.

3.3.6.3

Non-directional overcurrent protection PHxPTOC

The three-phase non-directional overcurrent functions are used for non-directional one-phase, two-phase and three-phase overcurrent and short-circuit protection with definite time or various inverse definite minimum time (IDMT) characteristic. The operation of a stage is based on three measuring principles: DFT, RMS or peak-to-peak values.

The preconfiguration includes low, high and instantaneous stages of non-directional overcurrent functions both for the high-voltage and the low-voltage side. The set of three phase currents, I3P, is connected to the inputs. The inrush detected by the differential protection function can increase the start value of instantaneous stage overcurrent function on the high-voltage side protection.

A common operate and start signal from three non-directional overcurrent functions from the high-voltage side are connected to an OR-gate to form a combined non-directional high-voltage side overcurrent operate and start signal which is used to provide a LED indication on the LHMI. Similarly a common operate and start signal from three non-directional overcurrent functions from the low-voltage side are connected to an OR-gate to form a combined non-directional low-voltage side overcurrent operate and start signal which is also used for providing a LED indication on the LHMI. Also separate start and operate signals from all the six OC functions are connected to the disturbance recorder.

Instantaneous overcurrent function block of low-voltage side can be blocked by an incoming signal available at binary input COM BI9. Similarly, the high-stage overcurrent function block of high-voltage side can be blocked by an incoming signal COM BI9 or from the START of the high-stage low-voltage side overcurrent protection.

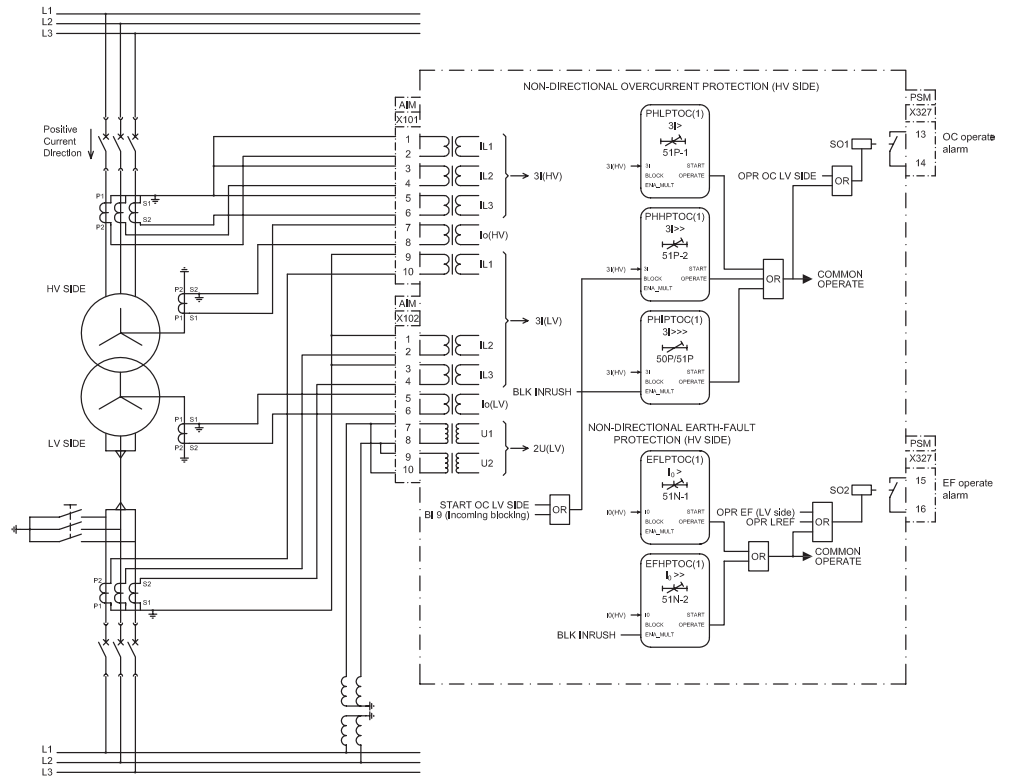

Figure 20: Non-directional overcurrent protection

3.3.6.4

Negative-sequence overcurrent protection NSPTOC

Two instances of negative-sequence overcurrent detection are provided, one for high-voltage side and another for low-voltage side, for protection against single-phasing, unbalanced load or asymmetrical voltage. The set of three phase currents, I3P, is connected to the inputs.

A common operate and start signal from both NSPTOC functions are connected to an OR-gate to form a combined negative-sequence overcurrent operate and start signal which is used to provide a LED indication on the LHMI. Also separate start and operate signals from the NSPTOC function is connected to the disturbance recorder.

3.3.6.5

Non-directional earth-fault protection EFxPTOC

The non-directional earth-fault protection functions are used for protection under earth-fault conditions with definite-time (DT) or with inverse definite minimum time (IDMT) characteristic when appropriate.

The operation of the stage is based on three measuring principles: DFT, RMS or peak-to-peak values. The configuration includes two instances of high and low stage non-directional earth-fault function blocks for high-voltage and low-voltage sides of the transformer. Transformer neutral currents from the high-voltage and low-voltage side are connected to the inputs. The inrush detected by the differential protection function can increase the start value of instantaneous earth-fault function.

A common operate and start signal from the high-stage and low-stage earth-fault protection functions are connected to an OR-gate to form a combined non-directional earth-fault operate and start signal which is used to provide a LED indication on the LHMI. Also separate start and operate signals from all of these functions are connected to the disturbance recorder.

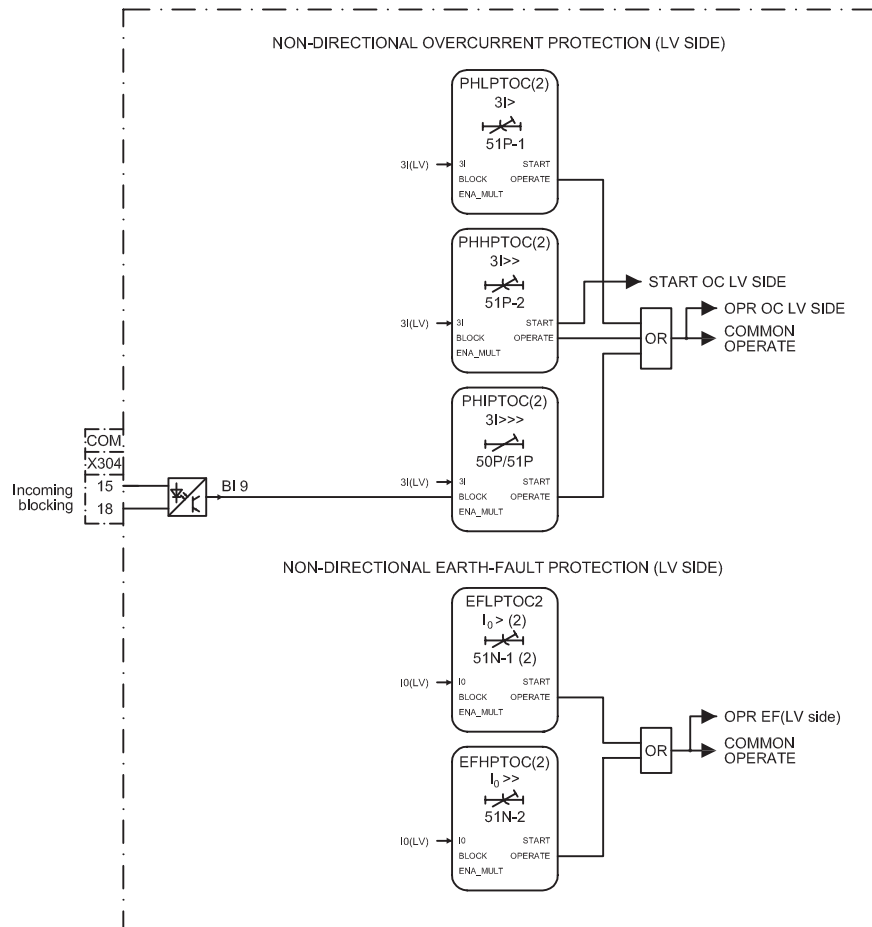

Figure 21: Non-directional earth-fault protection

3.3.6.6

Thermal overload protection T2PTTR

The three-phase thermal overload protection function is used for thermal protection of the power transformers. It has adjustable temperature limits for tripping, alarm and reclose inhibit. The thermal model applied uses two time constants and the true RMS current measuring principle. Reclose inhibit is programmed to block the circuit breaker in case the thermal values are above inhibit levels.

The operate signal from the thermal overload protection is further used to trigger the disturbance recorder. Both operate and alarm signals provide a LED indication on the LHMI.



The operate signal from the thermal overload protection is normally used for tripping of the low-voltage side breaker only.

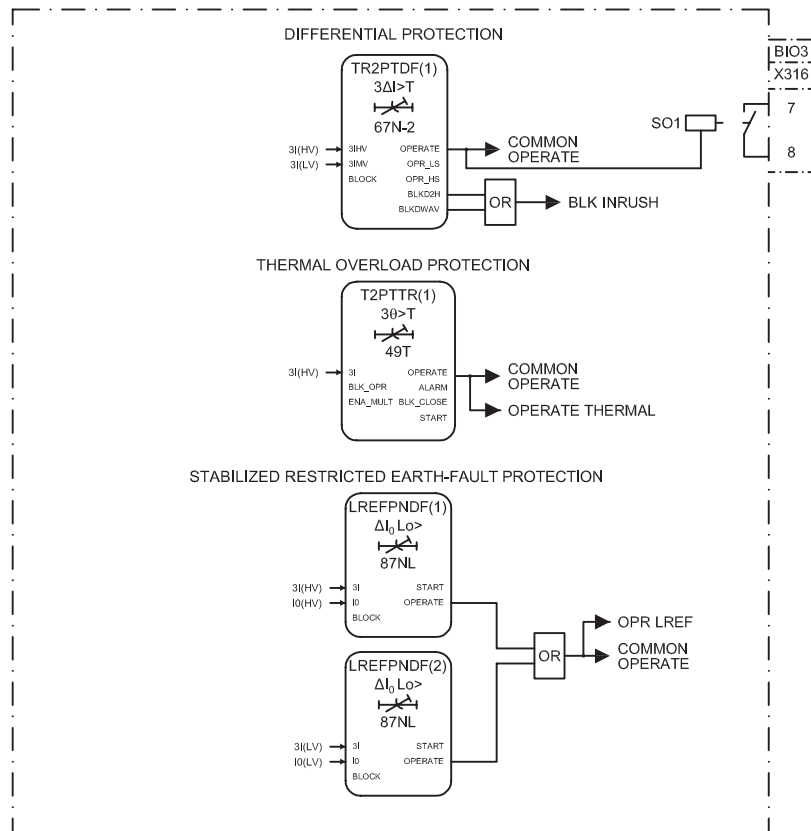

Figure 22: Thermal overload protection

3.3.6.7

Three-phase overvoltage protection PHPTOV

The three-phase overvoltage protection function is designed to be used for one-phase, two-phase and three-phase phase-to-earth or phase-to-phase overvoltage protection with definite time or various inverse definite minimum time (IDMT) characteristic.

The preconfiguration includes two instances of phase overvoltage function blocks for protection on low-voltage side. The set of three phase voltages, U3P, is connected to the inputs. The preconfiguration is build on a HW variant with three voltage inputs where you can use either phase-to-earth or phase-to-phase voltages.

A common operate and start signal from both overvoltage functions of low-voltage side are connected to an OR-gate to form a combined low-voltage side overvoltage operate and start signal which is used to provide a LED indication on the LHMI. Also separate start and operate signals from both instances are connected to the disturbance recorder.

3.3.6.8 Three-phase undervoltage protection PHPTUV

The three-phase undervoltage protection function is designed to be used for one-phase, two-phase and three-phase phase-to-earth or phase-to-phase overvoltage protection with definite time or various inverse definite minimum time (IDMT) characteristic.

The configuration includes two instances of phase undervoltage function blocks for protection on low-voltage side. The set of three phase voltages, U3P, is connected to the inputs. The preconfiguration is build on a HW variant with two voltage inputs where you can use either phase-to-earth or phase-to-phase voltages.

A common operate and start signal from both undervoltage protection functions of low-voltage side are connected to an OR-gate to form a combined low-voltage side undervoltage operate and start signal which is used to provide a LED indication on the LHMI. Also separate start and operate signals from both instances are connected to the disturbance recorder. Both undervoltage functions can be blocked by fuse failure supervision.

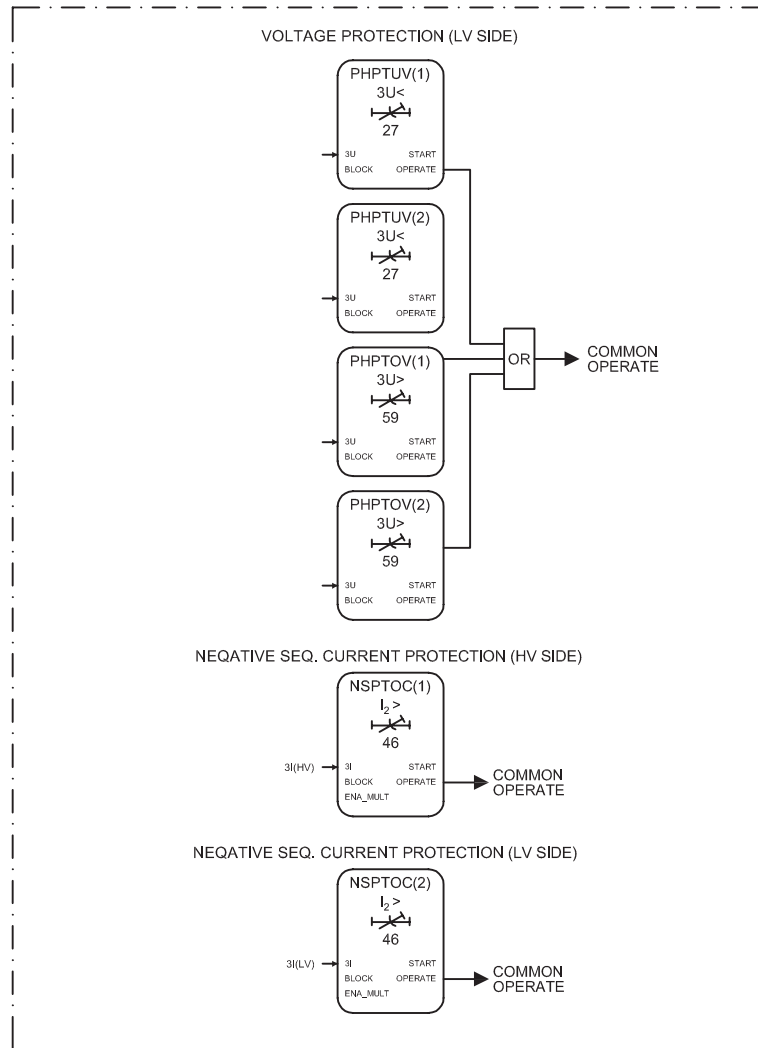

Figure 23: Three-phase undervoltage protection

3.3.6.9

Circuit-breaker failure protection CCBRRF

The function is activated by the common operate command from the protection functions. The breaker failure function issues a backup trip command to adjacent circuit breakers in case the main circuit breaker fails to trip for the protected component. The backup trip is connected at binary output BIO_3 PO3.

A failure of a circuit breaker is detected by measuring the current or by detecting the remaining trip signal. Function also provides retrip. Retrip is used along with the main trip, and is activated before the backup trip signal is generated in case the main breaker fails to open. Retrip is used to increase the operational reliability of the circuit breaker.

3.3.6.10 Tripping logic TRPPTRC

Two tripping circuits, one for high-voltage side and other for low-voltage side breaker, have been configured to provide tripping signal of required duration. The tripping circuit opens the high-voltage side circuit breaker on

- Receipt of operate signal from the protection function or
- Retrip signal from the circuit-breaker failure protection.

The circuit breaker of the low-voltage side is open on receipt of operate signal from the protection function or retrip signal. Master tripping signals for high-voltage and low-voltage circuit breaker are available at binary output PSM PO1 and PSM PO2 respectively.

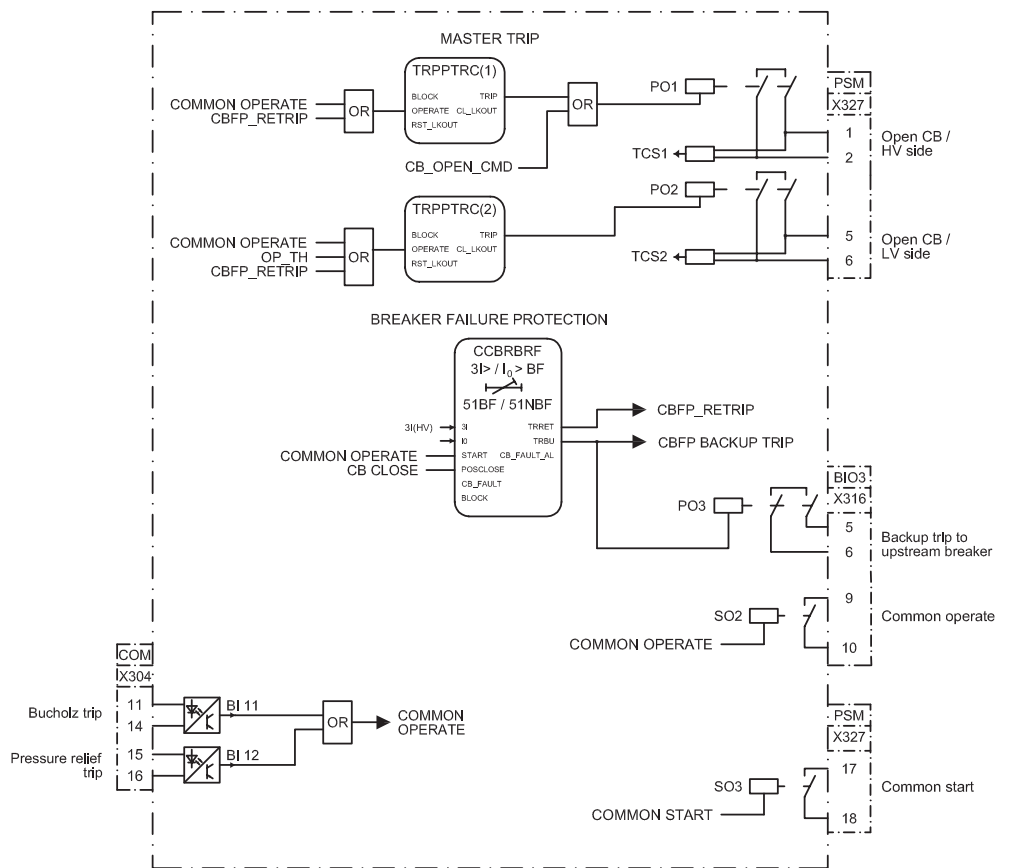

Figure 24: Tripping logic

3.3.6.11 Combined operate and start alarm signal

The operate outputs of all protection functions are combined in an OR-gate to get a common Operate output. This common operate signal is connected to a tripping logic. It is also available as an alarm binary output, BIO_3_SO2, with a settable minimum alarm delay of 80 ms. Also, a common Start output is derived from the

start outputs of protection functions combined in an OR-gate. The output is available as an alarm binary output PSM SO3 with a settable minimum alarm delay of 80 ms.

3.3.6.12 Other output and alarm signals

- Combined high-voltage and low-voltage side overcurrent operate available at binary output PSM SO1
- Combined EF/LREF operate alarm available at binary output PSM SO2
- Differential operate alarm available at binary output BIO_3 SO1
- Combined external Buchholz and pressure relief trip available at binary output BIO_3 SO3
- Combined alarm from high-voltage side circuit breaker monitoring function available at binary output BIO_3 SO4
- Combined alarm from various supervision functions available at binary output BIO_3 SO5

3.3.7 Supervision functions

3.3.7.1 Trip circuit supervision TCSSCBR

One instance of trip circuit supervision function is used for supervising the tripping circuit of the high-voltage side circuit breaker. Function continuously supervises the trip circuit and an alarm is issued in case of a failure of a trip circuit. The function block does not perform the supervision itself but it is used as an aid for configuration. The function is blocked when any protection function operate signal is active or the high-voltage side circuit breaker is open to prevent unwanted alarms.

The other instance of trip circuit supervision is used to check the proper functioning of the closing circuit of high-voltage side circuit breaker. The function is blocked when circuit breaker is in closed position to prevent unwanted alarms. Alarms from the both instances are separately connected to the binary recorder.

3.3.7.2 Circuit-breaker condition monitoring SSCBR

The circuit-breaker condition monitoring function checks for the health of the high-voltage side circuit breaker. The circuit breaker status is connected to the function via binary inputs. Function requires also pressure lockout input and spring charged input connected via binary input COM_101.BI13 and COM_101.BI14 respectively. Various alarm outputs from the function are combined in an OR-gate to create a master circuit-breaker monitoring alarm, which is available at binary output BIO_3 SO4.

All of the alarms are separately connected to the binary recorder and a combined alarm is available as an indication via a LED on the LHMI.

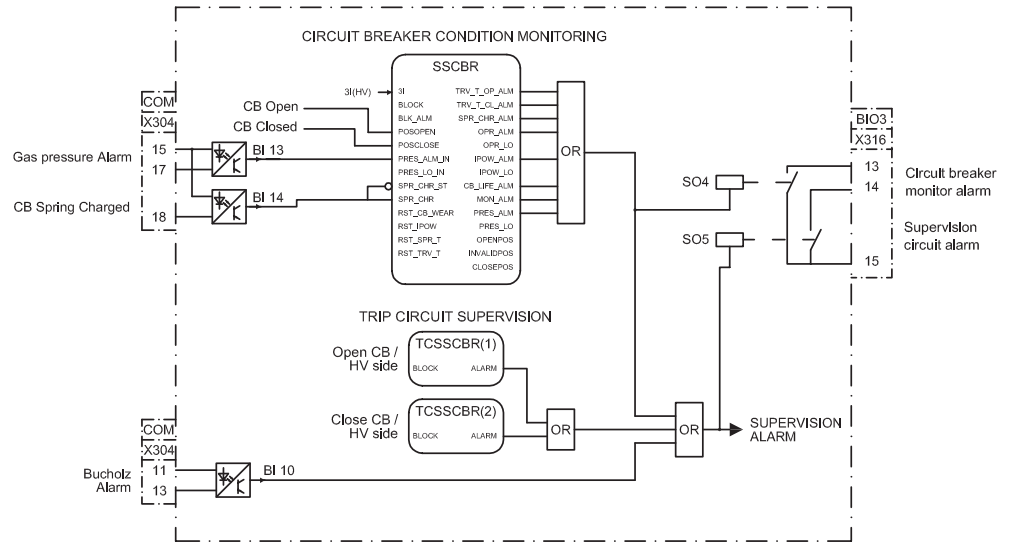

Figure 25: Circuit-breaker condition monitoring

3.3.8

Measurement and analog recording functions

The measured quantities in this configuration are:

- Phase current measurements
 - Winding 1
 - Winding 2
- Residual current measurements
 - Winding 1
 - Winding 2
- Differential and bias currents
- Phase voltage measurements
- Phase-to-phase voltage measurements

The measured quantities can be viewed in the measurement menu on the LHMI.

All analog input channels are connected to the analog disturbance recorder. When any of these analog values violate the upper or lower threshold limits, the recorder unit is triggered which in turn will record all the signals connected to the recorder.

Table 17: Signals connected to the analog recorder

Channel ID	Description
Channel 1	High-voltage side phase A current
Channel 2	High-voltage side phase B current
Channel 3	High-voltage side phase C current
Channel 4	High-voltage side neutral current
Channel 5	Low-voltage side phase A current

Table continues on next page

Channel ID	Description
Channel 6	Low-voltage side phase B current
Channel 7	Low-voltage side phase C current
Channel 8	Low-voltage side neutral current
Channel 9	Low-voltage side phase A voltage
Channel 10	Low-voltage side phase B voltage



Data connected to analog channels contain 20 samples per cycle.

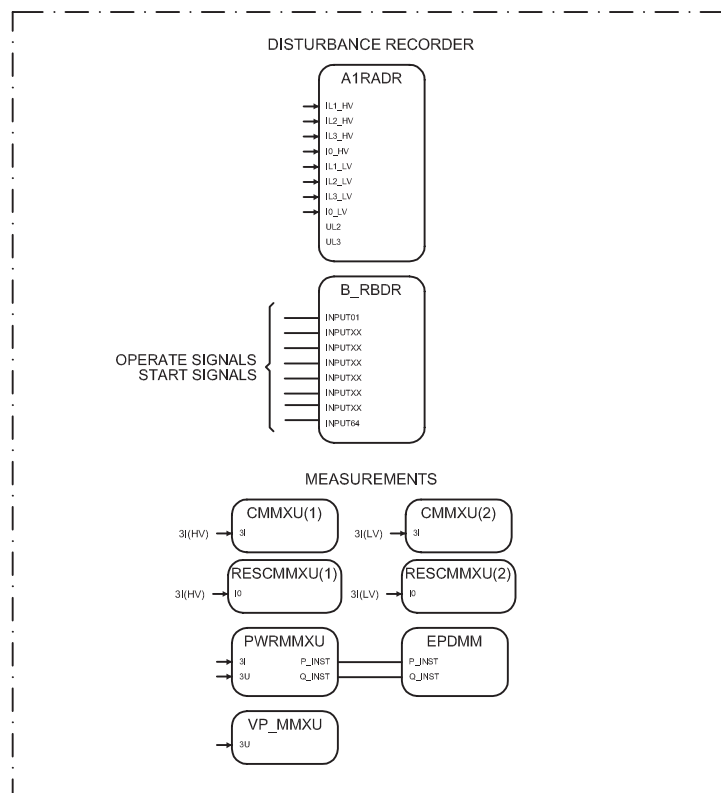

Figure 26: Measurement and analog recording

3.3.9

Binary recording and LED configuration

All of the start and operate outputs from the respective protection functions, various alarms from supervision functions, and important signals from control and protective functions are connected to a binary recorder. In case of a fault, the binary recorder is triggered which in turn will record all the signals connected to the recorder.

Table 18: *Signals connected to the binary recorder*

Channel ID	Description
Channel 1	Start of high-voltage side overcurrent high stage
Channel 2	Operate of high-voltage side overcurrent high stage
Channel 3	Start of high-voltage side overcurrent instantaneous stage
Channel 4	Operate of high-voltage side overcurrent instantaneous stage
Channel 5	Start of high-voltage side overcurrent low stage
Channel 6	Operate of high-voltage side overcurrent low stage
Channel 7	Start of low-voltage side overcurrent high stage
Channel 8	Operate of low-voltage side overcurrent high stage
Channel 9	Start of low-voltage side overcurrent instantaneous stage
Channel 10	Operate of low-voltage side overcurrent instantaneous stage
Channel 11	Start of low-voltage side overcurrent low stage
Channel 12	Operate of low-voltage side overcurrent low stage
Channel 13	Start of high-voltage side earth fault high stage
Channel 14	Operate of high-voltage side earth fault high stage
Channel 15	Start of high-voltage side earth fault low stage
Channel 16	Operate of high-voltage side earth fault low stage
Channel 17	Start of low-voltage side earth fault high stage
Channel 18	Operate of low-voltage side earth fault high stage
Channel 19	Start of low-voltage side earth fault low stage
Channel 20	Operate of low-voltage side earth fault low stage
Channel 21	Start of high-voltage side stabilized restricted earth fault
Channel 22	Operate of high-voltage side stabilized restricted earth fault
Channel 23	Start of low-voltage side stabilized restricted earth fault
Channel 24	Operate of low-voltage side stabilized restricted earth fault
Channel 25	Start of high-voltage side negative-sequence overcurrent
Channel 26	Operate of high-voltage side negative-sequence overcurrent
Channel 27	Start of low-voltage side negative-sequence overcurrent
Channel 28	Operate of low-voltage side negative-sequence overcurrent
Channel 29	Operate of thermal overload
Channel 30	Operate of differential protection high stage
Channel 31	Operate of differential protection low stage
Channel 32	Start of low-voltage side overvoltage stage 1
Channel 33	Operate of low-voltage side overvoltage stage 1
Channel 34	Start of low-voltage side overvoltage stage 2
Channel 35	Operate of low-voltage side overvoltage stage 2
Channel 36	Start of low-voltage side undervoltage stage 1
Channel 37	Operate of low-voltage side undervoltage stage 1
Channel 38	Start of low-voltage side undervoltage stage 2
Table continues on next page	

Channel ID	Description
Channel 39	Operate of low-voltage side undervoltage stage 2
Channel 40	Blocked by second harmonic from differential protection
Channel 41	Waveform blocking from differential protection
Channel 42	Blocked by thermal overload protection
Channel 43	Circuit breaker closed
Channel 44	Circuit breaker is open
Channel 45	Backup trip from circuit-breaker failure protection
Channel 46	Retrip from circuit-breaker failure protection
Channel 47	Trip circuit alarm 1 (supervising high-voltage breaker trip)
Channel 48	Trip circuit alarm 2 (supervising high-voltage breaker closing circuit)
Channel 49	Circuit breaker maintenance alarm: accumulated energy exceeds the set limit
Channel 50	Circuit breaker not operated since long
Channel 51	Closing time of circuit breaker exceeded the limit
Channel 52	Opening time of circuit breaker exceeded the limit
Channel 53	Pressure in circuit breaker below lockout limit
Channel 54	Spring charge time of circuit breaker exceeded the limit
Channel 55	Number of circuit breaker operation exceeded the set limit
Channel 56	Circuit breaker maintenance alarm: number of operations exceeds the set limit
Channel 57	External blocking signal
Channel 58	Buchholz alarm
Channel 59	Buchholz trip
Channel 60	Pressure relief trip

The LEDs are configured for alarm indications.

Table 19: LEDs configured on LHMI alarm page 1

LED No	LED color	Description
LED 1	Red	Operate from low stage differential protection
LED 2	Red	Operate from high stage differential protection
LED 3	Yellow	Combined start from high-voltage side OC protection
LED 3	Red	Combined operate from high-voltage side OC protection
LED 4	Yellow	Combined start from low-voltage side OC protection
LED 4	Red	Combined operate from low-voltage side OC protection
LED 5	Yellow	Combined start from high-voltage side EF protection
LED 5	Red	Combined operate from high-voltage side EF protection
LED 6	Yellow	Combined start from low-voltage side EF protection
LED 6	Red	Combined operate from low-voltage side EF protection
LED 7	Yellow	Combined start from stabilized restricted EF
LED 7	Red	Combine operate from stabilized restricted EF

Table continues on next page

LED No	LED color	Description
LED 8	Yellow	Alarm from thermal overload
LED 8	Red	Operate from thermal overload
LED 9	Yellow	Combined start from NSOC
LED 9	Red	Combined operate from NSOC
LED 10	Yellow	Combined start from low-voltage side overvoltage protection
LED 10	Red	Combine operate from low-voltage side overvoltage protection
LED 11	Yellow	Combined start from low-voltage side undervoltage protection
LED 11	Red	Combined operate from low-voltage side undervoltage protection
LED 12	Yellow	Backup trip from circuit-breaker protection function
LED 12	Red	Retrip from circuit-breaker protection function
LED 13	Red	Supervision alarms
LED 14	Red	External trip
LED 15	Red	Alarm from circuit-breaker monitoring function

Section 4 Requirements for measurement transformers

4.1 Current transformers

4.1.1 Current transformer requirements for non-directional overcurrent protection

For reliable and correct operation of the overcurrent protection, the CT has to be chosen carefully. The distortion of the secondary current of a saturated CT may endanger the operation, selectivity, and co-ordination of protection. However, when the CT is correctly selected, a fast and reliable short circuit protection can be enabled.

The selection of a CT depends not only on the CT specifications but also on the network fault current magnitude, desired protection objectives, and the actual CT burden. The protection settings of the IED should be defined in accordance with the CT performance as well as other factors.

4.1.1.1 Current transformer accuracy class and accuracy limit factor

The rated accuracy limit factor (F_n) is the ratio of the rated accuracy limit primary current to the rated primary current. For example, a protective current transformer of type 5P10 has the accuracy class 5P and the accuracy limit factor 10. For protective current transformers, the accuracy class is designed by the highest permissible percentage composite error at the rated accuracy limit primary current prescribed for the accuracy class concerned, followed by the letter "P" (meaning protection).

Table 20: Limits of errors according to IEC 60044-1 for protective current transformers

Accuracy class	Current error at rated primary current (%)	Phase displacement at rated primary current		Composite error at rated accuracy limit primary current (%)
		minutes	centiradians	
5P	±1	±60	±1.8	5
10P	±3	-	-	10

The accuracy classes 5P and 10P are both suitable for non-directional overcurrent protection. The 5P class provides a better accuracy. This should be noted also if there are accuracy requirements for the metering functions (current metering, power metering, and so on) of the IED.

The CT accuracy primary limit current describes the highest fault current magnitude at which the CT fulfils the specified accuracy. Beyond this level, the secondary current of the CT is distorted and it might have severe effects on the performance of the protection IED.

In practise, the actual accuracy limit factor (F_a) differs from the rated accuracy limit factor (F_n) and is proportional to the ratio of the rated CT burden and the actual CT burden.

The actual accuracy limit factor is calculated using the formula:

$$F_a \approx F_n \times \frac{|S_{in} + S_n|}{|S_{in} + S|}$$

F_n	the accuracy limit factor with the nominal external burden S_n
S_{in}	the internal secondary burden of the CT
S	the actual external burden

4.1.1.2

Non-directional overcurrent protection

The current transformer selection

Non-directional overcurrent protection does not set high requirements on the accuracy class or on the actual accuracy limit factor (F_a) of the CTs. It is, however, recommended to select a CT with F_a of at least 20.

The nominal primary current I_{1n} should be chosen in such a way that the thermal and dynamic strength of the current measuring input of the IED is not exceeded. This is always fulfilled when

$$I_{1n} > I_{kmax} / 100,$$

I_{kmax} is the highest fault current.

The saturation of the CT protects the measuring circuit and the current input of the IED. For that reason, in practice, even a few times smaller nominal primary current can be used than given by the formula.

Recommended start current settings

If I_{kmin} is the lowest primary current at which the highest set overcurrent stage is to operate, the start current should be set using the formula:

$$\text{Current start value} < 0.7 \times (I_{kmin} / I_{1n})$$

I_{1n} is the nominal primary current of the CT.

The factor 0.7 takes into account the protection IED inaccuracy, current transformer errors, and imperfections of the short circuit calculations.

The adequate performance of the CT should be checked when the setting of the high set stage overcurrent protection is defined. The operate time delay caused by the CT saturation is typically small enough when the overcurrent setting is noticeably lower than F_a .

When defining the setting values for the low set stages, the saturation of the CT does not need to be taken into account and the start current setting is simply according to the formula.

Delay in operation caused by saturation of current transformers

The saturation of CT may cause a delayed IED operation. To ensure the time selectivity, the delay must be taken into account when setting the operate times of successive IEDs.

With definite time mode of operation, the saturation of CT may cause a delay that is as long as the time the constant of the DC component of the fault current, when the current is only slightly higher than the starting current. This depends on the accuracy limit factor of the CT, on the remanence flux of the core of the CT, and on the operate time setting.

With inverse time mode of operation, the delay should always be considered as being as long as the time constant of the DC component.

With inverse time mode of operation and when the high-set stages are not used, the AC component of the fault current should not saturate the CT less than 20 times the starting current. Otherwise, the inverse operation time can be further prolonged. Therefore, the accuracy limit factor F_a should be chosen using the formula:

$$F_a > 20 * \text{Current start value} / I_{1n}$$

The *Current start value* is the primary pickup current setting of the IED.

4.1.1.3

Example for non-directional overcurrent protection

The following figure describes a typical medium voltage feeder. The protection is implemented as three-stage definite time non-directional overcurrent protection.

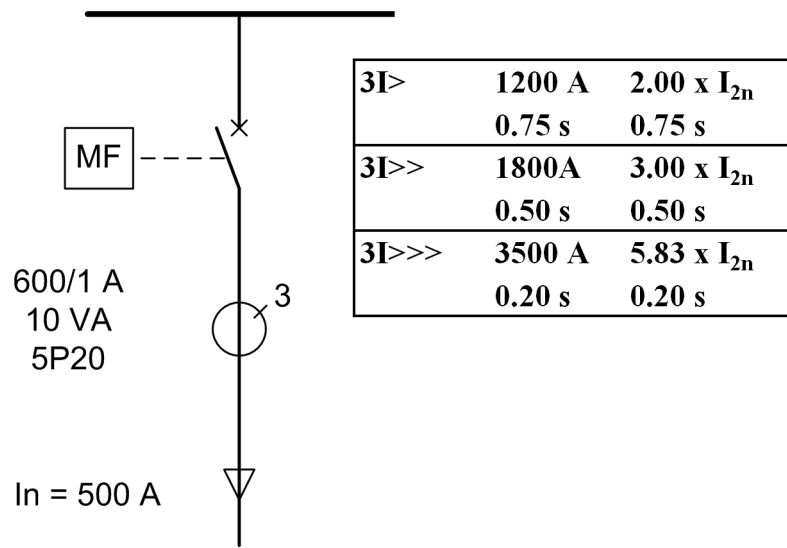

Figure 27: Example of three-stage overcurrent protection

The maximum three-phase fault current is 41.7 kA and the minimum three-phase short circuit current is 22.8 kA. The actual accuracy limit factor of the CT is calculated to be 59.

The start current setting for low-set stage (3I>) is selected to be about twice the nominal current of the cable. The operate time is selected so that it is selective with the next IED (not visible in the figure above). The settings for the high-set stage and instantaneous stage are defined also so that grading is ensured with the downstream protection. In addition, the start current settings have to be defined so that the IED operates with the minimum fault current and it does not operate with the maximum load current. The settings for all three stages are as in the figure above.

For the application point of view, the suitable setting for instantaneous stage (I>>>) in this example is 3 500 A (5.83 x I_{2n}). For the CT characteristics point of view, the criteria given by the current transformer selection formula is fulfilled and also the IED setting is considerably below the F_a. In this application, the CT rated burden could have been selected much lower than 10 VA for economical reasons.

4.1.2

Current transformer requirements for differential protection

The more important the object to be protected, the more attention has to be paid to the current transformers. It is not normally possible to dimension the current transformer so that they repeat the currents with high DC components without saturating when the residual flux of the current transformer is high. TR2PTDF operates reliably even though the current transformers are partially saturated.

The accuracy class recommended for current transformers to be used with TR2PTDF is 5P, in which the limit of the current error at the rated primary current is 1 percent and the limit of the phase displacement is 60 minutes. The limit of the composite error at the rated accuracy limit primary current is 5 percent.

The approximate value of the accuracy limit factor F_a corresponding to the actual current transformer burden can be calculated on the basis of the rated accuracy limit factor F_n at the rated burden, the rated burden S_n , the internal burden S_{in} and the actual burden S_a of the current transformer.

$$F_a = F_n \times \frac{S_{in} + S_n}{S_{in} + S_a}$$

(Equation 1)

F_a The approximate value of the accuracy limit factor (ALF) corresponding to the actual CT burden

F_n The rated accuracy limit factor at the rated burden of the current transformer

S_n The rated burden of the current transformer

S_{in} The internal burden of the current transformer

S_a The actual burden of the current transformer

Example 1

The rated burden S_n of the current transformer 5P20 is 10 VA, the secondary rated current is 5A, the internal resistance $R_{in} = 0.07 \Omega$ and the accuracy limit factor F_n corresponding to the rated burden is 20 (5P20). Thus the internal burden of the current transformer is $S_{in} = (5A)^2 * 0.07 \Omega = 1.75 \text{ VA}$. The input impedance of the IED at a rated current of 5A is $< 20 \text{ m}\Omega$. If the measurement conductors have a resistance of 0.113Ω , the actual burden of the current transformer is $S_a = (5A)^2 * (0.113 + 0.020) \Omega = 3.33 \text{ VA}$. Thus the accuracy limit factor F_a corresponding to the actual burden is approximately 46.

The CT burden can grow considerably at the rated current 5A. The actual burden of the current transformer decreases at the rated current of 1A while the repeatability simultaneously improves.

At faults occurring in the protected area, the currents may be very high compared to the rated currents of the current transformers. Due to the instantaneous stage of the differential function block, it is sufficient that the current transformers are capable of repeating the current required for instantaneous tripping during the first cycle.

Thus the current transformers usually are able to reproduce the asymmetric fault current without saturating within the next 10 ms after the occurrence of the fault to secure that the operate times of the IED comply with the retardation time.

The accuracy limit factors corresponding to the actual burden of the phase current transformer to be used in differential protection fulfill the requirement.

$$F_a > K_r \times I_{k_{max}} \times (T_{dc} \times \omega \times (1 - e^{-T_m/T_{dc}}) + 1)$$

(Equation 2)

$I_{k_{max}}$	The maximum through-going fault current (in p.u.) at which the protection is not allowed to operate
T_{dc}	The primary DC time constant related to $I_{k_{max}}$
ω	The angular frequency, that is, $2\pi \cdot f_n$
T_m	The time-to-saturate, that is, the duration of the saturation free transformation
K_r	The remanence factor $1/(1-r)$, where r is the maximum remanence flux in p.u. from saturation flux

The accuracy limit factors corresponding to the actual burden of the phase current transformer is used in differential protection.

The parameter r is the maximum remanence flux density in the CT core in p.u. from saturation flux density. The value of the parameter r depends on the magnetic material used and on the construction of the CT. For instance, if the value of $r = 0.4$, the remanence flux density can be 40 percent of the saturation flux density. The manufacturer of the CT has to be contacted when an accurate value for the parameter r is needed. The value $r = 0.4$ is recommended to be used when an accurate value is not available.

The required minimum time-to-saturate T_m in TR2PTDF is half fundamental cycle period (10 ms when $f_n = 50\text{Hz}$).

Two typical cases are considered for the determination of the sufficient accuracy limit factor (F_a):

1. A fault occurring at the substation bus:
The protection must be stable at a fault arising during a normal operating situation. Re-energizing the transformer against a bus fault leads to very high fault currents and thermal stress and therefore re-energizing is not preferred in this case. Thus, the remanence can be neglected.
The maximum through-going fault current $I_{k_{max}}$ is typically 10 p.u. for a substation main transformer. At a short circuit fault close to the supply transformer, the DC time constant (T_{dc}) of the fault current is almost the same as that of the transformer, the typical value being 100 ms.

$I_{k_{max}}$	10 p.u.
T_{dc}	100 ms
ω	100π Hz
T_m	10 ms
K_r	1

When the values are substituted in [Equation 4](#), the result is:

$$F_a > K_r \times I_{k_{\max}} \times (T_{dc} \times \omega \times (1 - e^{-T_m/T_{dc}}) + 1) \approx 40$$

2. Re-energizing against a fault occurring further down in the network:
The protection must be stable also during re-energization against a fault on the line. In this case, the existence of remanence is very probable. It is assumed to be 40 percent here.

On the other hand, the fault current is now smaller and since the ratio of the resistance and reactance is greater in this location, having a full DC offset is not possible. Furthermore, the DC time constant (T_{dc}) of the fault current is now smaller, assumed to be 50 ms here.

Assuming a maximum fault current being 30 percent lower than in the bus fault and a DC offset 90 percent of the maximum.

$$\begin{aligned} I_{k_{\max}} & 0.7 \times 10 = 7 \text{ (p.u.)} \\ T_{dc} & 50 \text{ ms} \\ \omega & 100\pi \text{ Hz} \\ T_m & 10 \text{ ms} \\ K_r & 1/(1-0.4) = 1.6667 \end{aligned}$$

When the values are substituted in the equation, the result is:

$$F_a > K_r \times I_{k_{\max}} \times 0.9 \times (T_{dc} \times \omega \times (1 - e^{-T_m/T_{dc}}) + 1) \approx 40$$

If the actual burden of the current transformer (S_a) in [Equation 4](#) cannot be reduced low enough to provide a sufficient value for F_a , there are two alternatives to deal with the situation:

- a CT with a higher rated burden S_n can be chosen (which also means a higher rated accuracy limit F_n)
- a CT with a higher nominal primary current I_{1n} (but the same rated burden) can be chosen

Example 2

Assuming that the actions according to alternative two above are taken in order to improve the actual accuracy limit factor:

$$F_a = \frac{I_r CT}{I_r TR} * F_n$$

(Equation 3)

$I_r TR$ 1000 A (rated secondary side current of the power transformer)

$I_r CT$ 1500 A (rated primary current of the CT on the transformer secondary side)

F_n 30 (rated accuracy limit factor of the CT)

$$F_a = (I_{rCT} / I_{rTR}) * F_n \text{ (actual accuracy limit factor due to oversizing the CT)} = (1500/1000) * 30 = 45$$

In TR2PTDF, it is important that the accuracy limit factors F_a of the phase current transformers at both sides correspond with each other, that is, the burdens of the current transformers on both sides are to be as equal as possible. If high inrush or start currents with high DC components pass through the protected object when it is connected to the network, special attention is required for the performance and the burdens of the current transformers and for the settings of the function block.

Section 5 Glossary

100BASE-FX	A physical medium defined in the IEEE 802.3 Ethernet standard for local area networks (LANs) that uses fibre-optic cabling
ANSI	American National Standards Institute
BI/O	Binary input/output
BIO	Binary input and output
COMTRADE	Common format for transient data exchange for power systems. Defined by the IEEE Standard.
CPU	Central processing unit
CT	Current transformer
DNP3	A distributed network protocol originally developed by Westronic. The DNP3 Users Group has the ownership of the protocol and assumes responsibility for its evolution.
EMC	Electromagnetic compatibility
Ethernet	A standard for connecting a family of frame-based computer networking technologies into a LAN
GOOSE	Generic Object-Oriented Substation Event
HMI	Human-machine interface
HW	Hardware
IDMT	Inverse definite minimum time
IEC	International Electrotechnical Commission
IEC 60870-5-103	Communication standard for protective equipment; A serial master/slave protocol for point-to-point communication
IEC 61850	International standard for substation communication and modeling
IEC 61850-8-1	A communication protocol based on the IEC 61850 standard series
IED	Intelligent electronic device
IRIG-B	Inter-Range Instrumentation Group's time code format B
LAN	Local area network
LC	Connector type for glass fibre cable
LED	Light-emitting diode

LHMI	Local human-machine interface
PCM600	Protection and Control IED Manager
RET630	Transformer protection and control IED
RJ-45	Galvanic connector type
RMS	Root-mean-square (value)
RTD	Resistance temperature detector
SNTP	Simple Network Time Protocol
SW	Software
TCP/IP	Transmission Control Protocol/Internet Protocol
TCS	Trip-circuit supervision
VT	Voltage transformer
WAN	Wide area network
WHMI	Web human-machine interface

Contact us

ABB Oy

Distribution Automation

P.O. Box 699

FI-65101 VAASA, Finland

Phone +358 10 22 11

Fax +358 10 22 41094

www.abb.com/substationautomation