



Relion® Protection and Control

Feeder Protection and Control REF615R Quick Installation Guide

Power and productivity
for a better world™





Document ID: 1MRS240038-IB
Issued: 11/22/2013
Revision: A
Product version: 4.0

© Copyright 2013 ABB. All rights reserved.

REF615R IED

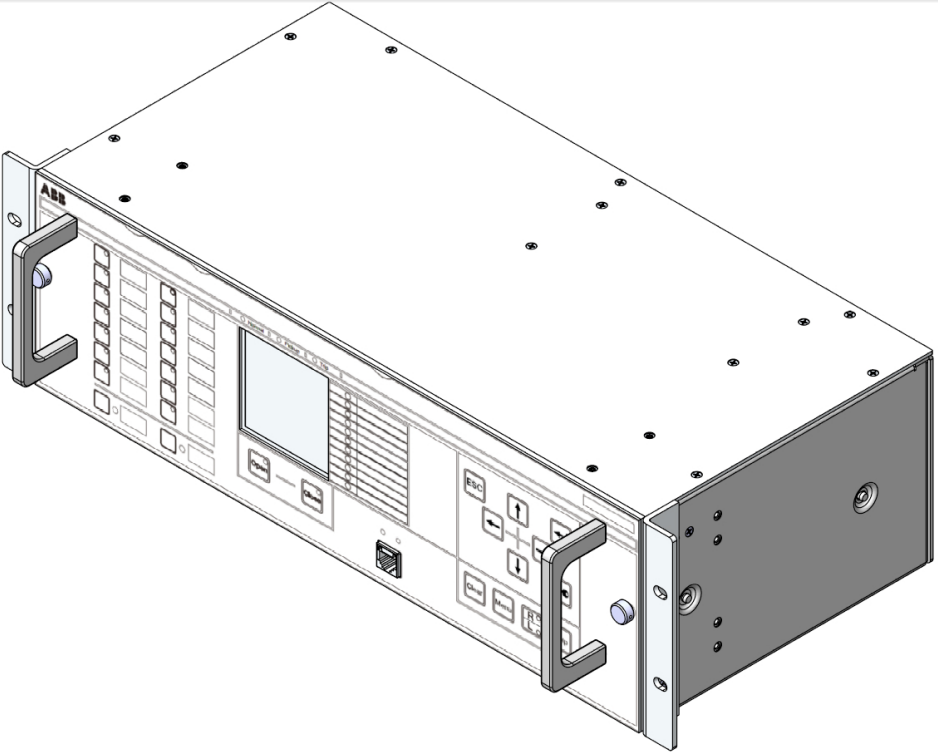

Withdrawing the plug-in unit from the case

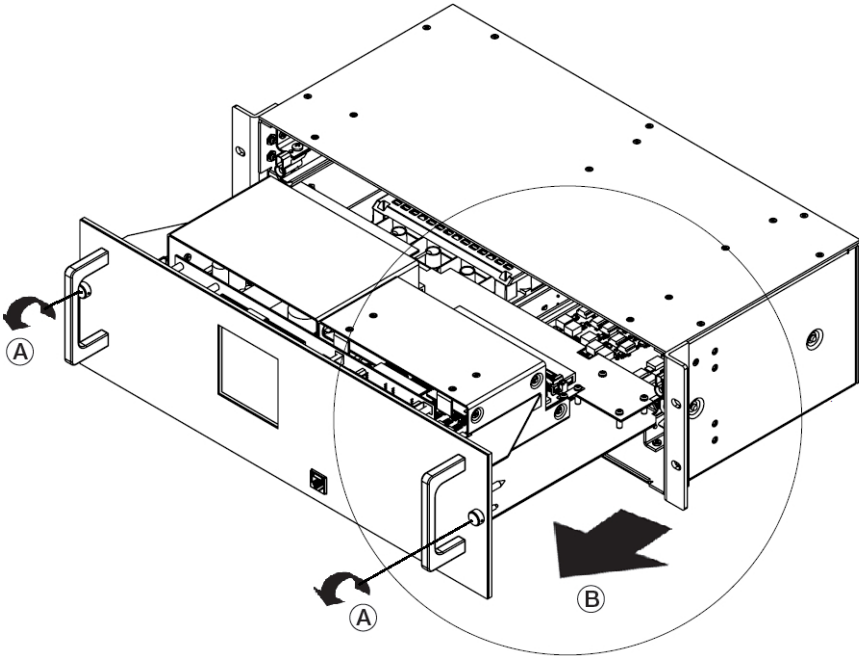

19" Rack Mounting

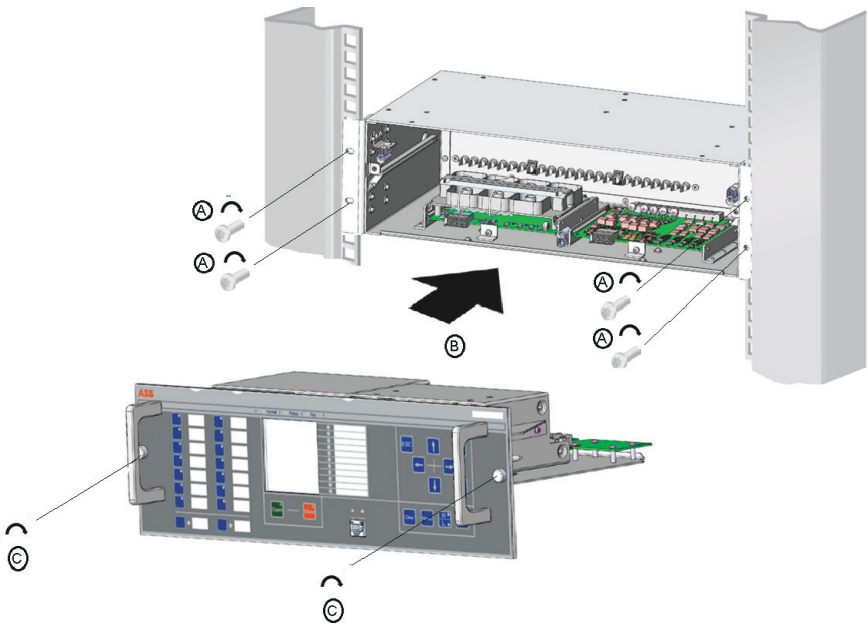

Adjusting the unit for 19" rack Semi projection

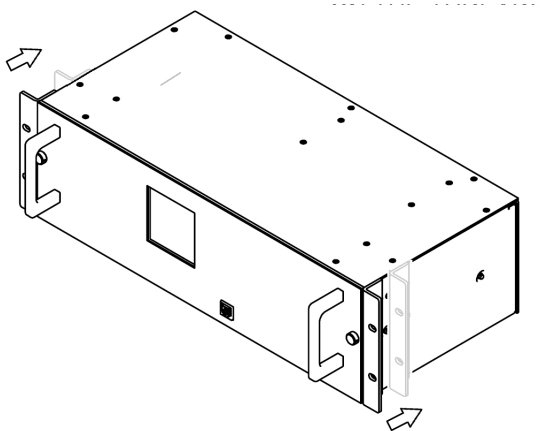

Panel Mounting

A. Panel Mounting Kit (Optional Accessory)

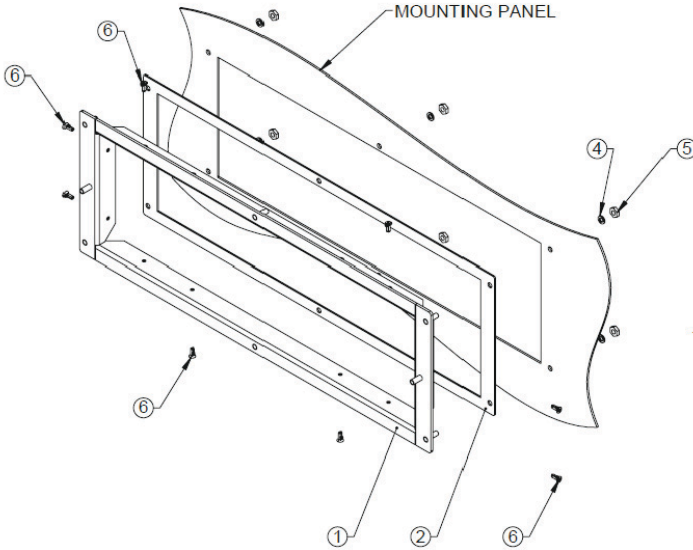

Pos.	Part ID	Title	0001
1	2RGA018541A0001	PANEL MOUNT BEZEL	1
2	2RGA018748P0001	BEZEL GASKET ABB #613641	1
4	3WGA014049P0005	#10, LOCK WASHER, MEDIUM SPLIT, SSTL, ANSI B18.21.1	6
5	3WGA014050P0006	10-32 HEX NUT, UNC, SSTL, ANSI B18.6.3	6
6	3WGA018443P0004	6-32 X 3/8 Flat Hd Phillips Mach Screw, 82°, 18-8 SS, B18.6.3	8

B. Panel Mounting Process

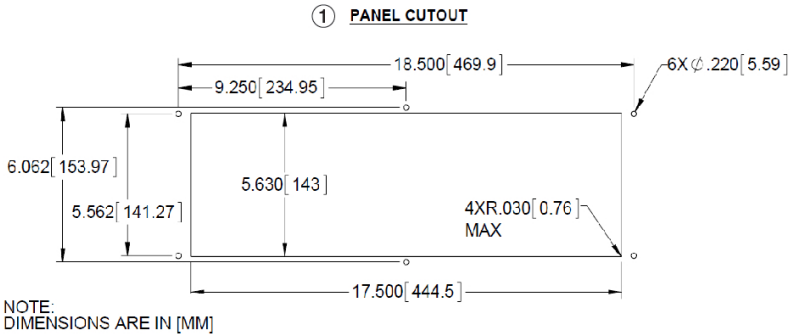

6
INSERT UNIT IN
PANEL CUTOUT

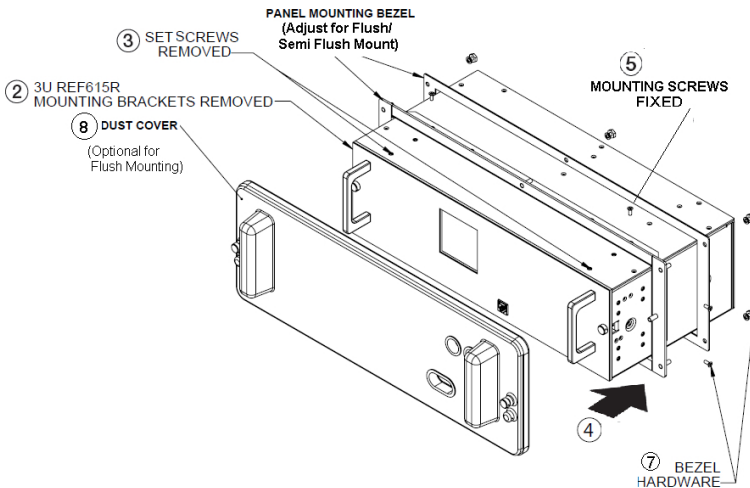

Safety Ground

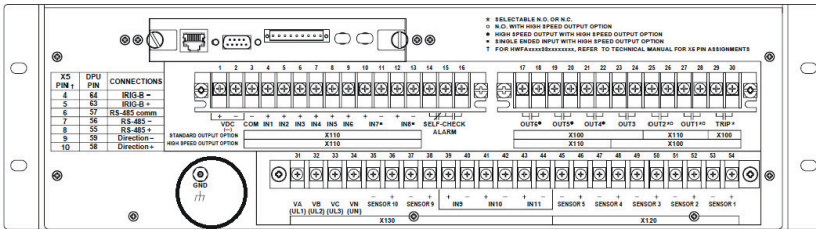
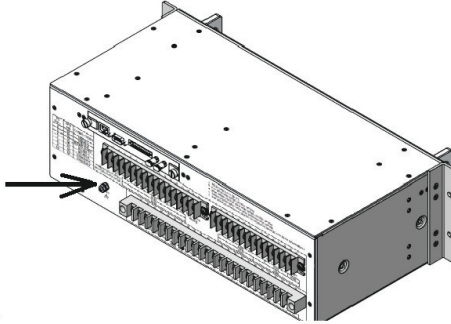

Notes:

Contact us

ABB Oy

Distribution Automation

P.O. Box 699

FI-65101 VAASA, Finland

Phone +358 10 22 11

Fax +358 10 22 41094

ABB Inc.

Distribution Automation

4300 Coral Ridge Drive

Coral Springs, FL 33065, USA

Phone +1 (800) 523-2620

Phone +1 954-752-6700

Fax +1 954 345-5329

ABB Transmission and Distribution Automation Equipment (Xiamen) Co. Ltd.

ABB Industrial Park, Torch Hi-tech

Development Zone 361006

Xiamen, Fujian, China

Phone +86 592 5702288

Fax +86 592 5718598

ABB Limited

Distribution Automation

Maneja, Vadodara 390013, India

Phone: +91 265 2604032

Fax: +91 265 2638922

www.abb.com/substationautomation