

Relion® 650 SERIES

Bay control REC650

Version 1.3 IEC

Technical manual





Document ID: 1MRK 511 287-UEN

Issued: November 2019

Revision: B

Product version: 1.3

© Copyright 2013 ABB. All rights reserved

Copyright

This document and parts thereof must not be reproduced or copied without written permission from ABB, and the contents thereof must not be imparted to a third party, nor used for any unauthorized purpose.

The software and hardware described in this document is furnished under a license and may be used or disclosed only in accordance with the terms of such license.

This product includes software developed by the OpenSSL Project for use in the OpenSSL Toolkit. (<http://www.openssl.org/>)

This product includes cryptographic software written/developed by: Eric Young (eay@cryptsoft.com) and Tim Hudson (tjh@cryptsoft.com).

Trademarks

ABB and Relion are registered trademarks of the ABB Group. All other brand or product names mentioned in this document may be trademarks or registered trademarks of their respective holders.

Warranty

Please inquire about the terms of warranty from your nearest ABB representative.

ABB AB

Grid Automation Products

SE-721 59 Västerås

Sweden

Telephone: +46 (0) 21 32 50 00

Facsimile: +46 (0) 21 14 69 18

<http://www.abb.com/protection-control>

Disclaimer

The data, examples and diagrams in this manual are included solely for the concept or product description and are not to be deemed as a statement of guaranteed properties. All persons responsible for applying the equipment addressed in this manual must satisfy themselves that each intended application is suitable and acceptable, including that any applicable safety or other operational requirements are complied with. In particular, any risks in applications where a system failure and/or product failure would create a risk for harm to property or persons (including but not limited to personal injuries or death) shall be the sole responsibility of the person or entity applying the equipment, and those so responsible are hereby requested to ensure that all measures are taken to exclude or mitigate such risks.

This document has been carefully checked by ABB but deviations cannot be completely ruled out. In case any errors are detected, the reader is kindly requested to notify the manufacturer. Other than under explicit contractual commitments, in no event shall ABB be responsible or liable for any loss or damage resulting from the use of this manual or the application of the equipment.

Conformity

This product complies with the directive of the Council of the European Communities on the approximation of the laws of the Member States relating to electromagnetic compatibility (EMC Directive 2004/108/EC) and concerning electrical equipment for use within specified voltage limits (Low-voltage directive 2006/95/EC). This conformity is the result of tests conducted by ABB in accordance with the product standards EN 50263 and EN 60255-26 for the EMC directive, and with the product standards EN 60255-1 and EN 60255-27 for the low voltage directive. The product is designed in accordance with the international standards of the IEC 60255 series.

Table of contents

Section 1	Introduction.....	27
1.1	This manual.....	27
1.2	Intended audience.....	27
1.3	Product documentation.....	27
1.3.1	Product documentation set.....	27
1.3.2	Document revision history.....	28
1.3.3	Related documents.....	28
1.4	Symbols and conventions.....	29
1.4.1	Symbols.....	29
1.4.2	Document conventions.....	29
Section 2	Available functions.....	31
2.1	Control and monitoring functions.....	31
2.2	Back-up protection functions.....	34
2.3	Station communication.....	35
2.4	Basic IED functions.....	37
Section 3	Analog inputs.....	39
3.1	Introduction.....	39
3.2	Operation principle.....	39
3.3	Presumptions for technical data.....	40
3.4	Settings.....	40
Section 4	Binary input and output modules.....	47
4.1	Binary input.....	47
4.1.1	Binary input debounce filter.....	47
4.1.2	Oscillation filter.....	47
4.1.3	Settings.....	47
4.1.3.1	Setting parameters for binary input modules.....	47
4.1.3.2	Setting parameters for communication module.....	49
Section 5	Local Human-Machine-Interface LHMI.....	51
5.1	Local HMI screen behaviour.....	51
5.1.1	Identification.....	51
5.1.2	Settings.....	51
5.2	Local HMI signals.....	51
5.2.1	Identification.....	51
5.2.2	Function block.....	51
5.2.3	Signals.....	52
5.3	Basic part for LED indication module.....	52
5.3.1	Identification.....	52
5.3.2	Function block.....	52

5.3.3	Signals.....	53
5.3.4	Settings.....	53
5.4	LCD part for HMI function keys control module.....	54
5.4.1	Identification.....	54
5.4.2	Function block.....	54
5.4.3	Signals.....	54
5.4.4	Settings.....	55
5.5	Operation principle.....	55
5.5.1	Local HMI.....	55
5.5.1.1	Display.....	55
5.5.1.2	LEDs.....	58
5.5.1.3	Keypad.....	58
5.5.2	LED.....	59
5.5.2.1	Functionality.....	59
5.5.2.2	Status LEDs.....	60
5.5.2.3	Indication LEDs.....	60
5.5.3	Function keys.....	67
5.5.3.1	Functionality.....	67
5.5.3.2	Operation principle.....	67
Section 6	Current protection.....	69
6.1	Instantaneous phase overcurrent protection 3-phase output PHPIOC	69
6.1.1	Identification	69
6.1.2	Functionality.....	69
6.1.3	Function block.....	69
6.1.4	Signals.....	69
6.1.5	Settings.....	70
6.1.6	Monitored data.....	70
6.1.7	Operation principle.....	70
6.1.8	Technical data.....	70
6.2	Four step phase overcurrent protection 3-phase output OC4PTOC	71
6.2.1	Identification	71
6.2.2	Functionality.....	71
6.2.3	Function block.....	72
6.2.4	Signals.....	72
6.2.5	Settings.....	73
6.2.6	Monitored data.....	75
6.2.7	Operation principle.....	75
6.2.8	Second harmonic blocking element.....	79
6.2.9	Technical data.....	80
6.3	Instantaneous residual overcurrent protection EFPIOC	80
6.3.1	Identification	80
6.3.2	Functionality.....	80
6.3.3	Function block.....	81
6.3.4	Signals.....	81
6.3.5	Settings.....	81

6.3.6	Monitored data.....	81
6.3.7	Operation principle.....	82
6.3.8	Technical data.....	82
6.4	Four step residual overcurrent protection, zero, negative sequence direction EF4PTOC	82
6.4.1	Identification	82
6.4.2	Functionality.....	82
6.4.3	Function block.....	83
6.4.4	Signals.....	83
6.4.5	Settings.....	84
6.4.6	Monitored data.....	87
6.4.7	Operation principle.....	87
6.4.7.1	Operating quantity within the function.....	87
6.4.7.2	Internal polarizing.....	88
6.4.7.3	External polarizing for earth-fault function.....	90
6.4.7.4	Base quantities within the protection.....	90
6.4.7.5	Internal earth-fault protection structure.....	91
6.4.7.6	Four residual overcurrent steps.....	91
6.4.7.7	Directional supervision element with integrated directional comparison function.....	92
6.4.8	Second harmonic blocking element.....	95
6.4.9	Technical data.....	95
6.5	Sensitive directional residual overcurrent and power protection SDEPSDE	96
6.5.1	Identification.....	96
6.5.2	Functionality.....	96
6.5.3	Function block.....	97
6.5.4	Signals.....	97
6.5.5	Settings.....	98
6.5.6	Monitored data.....	99
6.5.7	Operation principle	99
6.5.7.1	Function inputs.....	99
6.5.7.2	Directional residual current protection measuring $3I_0 \cdot \cos \phi$	99
6.5.7.3	Directional residual power protection measuring $3I_0 \cdot 3U_0 \cdot \cos \phi$	102
6.5.7.4	Directional residual current protection measuring $3I_0$ and ϕ	103
6.5.7.5	Directional functions.....	103
6.5.7.6	Non-directional earth fault current protection.....	103
6.5.7.7	Residual overvoltage release and protection.....	104
6.5.8	Technical data.....	106
6.6	Thermal overload protection, one time constant Celsius/Fahrenheit LCPTTR/LFPTTR.....	107
6.6.1	Identification	107
6.6.2	Functionality.....	107
6.6.3	Function block.....	108
6.6.4	Signals.....	108
6.6.5	Settings.....	109
6.6.6	Monitored data.....	110

6.6.7	Operation principle.....	111
6.6.8	Technical data.....	113
6.7	Breaker failure protection 3-phase activation and output CCRBRF	114
6.7.1	Identification.....	114
6.7.2	Functionality.....	114
6.7.3	Function block.....	114
6.7.4	Signals.....	115
6.7.5	Settings.....	115
6.7.6	Monitored data.....	116
6.7.7	Operation principle.....	116
6.7.8	Technical data.....	118
6.8	Stub protection STBPTOC	119
6.8.1	Identification	119
6.8.2	Functionality.....	119
6.8.3	Function block.....	119
6.8.4	Signals.....	119
6.8.5	Settings.....	120
6.8.6	Monitored data.....	120
6.8.7	Operation principle.....	120
6.8.8	Technical data.....	121
6.9	Pole discordance protection CCRPLD	121
6.9.1	Identification	121
6.9.2	Functionality.....	122
6.9.3	Function block.....	122
6.9.4	Signals.....	122
6.9.5	Settings.....	123
6.9.6	Monitored data.....	123
6.9.7	Operation principle.....	123
6.9.7.1	Pole discordance signaling from circuit breaker.....	125
6.9.7.2	Unsymmetrical current detection.....	125
6.9.8	Technical data.....	125
6.10	Broken conductor check BRCPTOC	125
6.10.1	Identification.....	125
6.10.2	Functionality.....	126
6.10.3	Function block.....	126
6.10.4	Signals.....	126
6.10.5	Settings.....	126
6.10.6	Monitored data.....	127
6.10.7	Operation principle.....	127
6.10.8	Technical data.....	128
6.11	Directional over-/under-power protection GOPPDOP/GUPPDUP.....	128
6.11.1	Functionality.....	128
6.11.2	Directional overpower protection GOPPDOP	129
6.11.2.1	Identification.....	129
6.11.2.2	Function block.....	129
6.11.2.3	Signals.....	129

6.11.2.4	Settings.....	130
6.11.2.5	Monitored data.....	131
6.11.3	Directional underpower protection GUPPDUP.....	131
6.11.3.1	Identification.....	131
6.11.3.2	Function block.....	131
6.11.3.3	Signals.....	132
6.11.3.4	Settings.....	132
6.11.3.5	Monitored data.....	133
6.11.4	Operation principle.....	133
6.11.4.1	Low pass filtering.....	135
6.11.5	Technical data.....	136
6.12	Negative sequence based overcurrent function DNSPTOC	136
6.12.1	Identification.....	136
6.12.2	Functionality.....	136
6.12.3	Function block.....	137
6.12.4	Signals.....	137
6.12.5	Settings.....	138
6.12.6	Monitored data.....	139
6.12.7	Operation principle.....	139
6.12.8	Technical data.....	139
Section 7	Voltage protection.....	141
7.1	Two step undervoltage protection UV2PTUV	141
7.1.1	Identification.....	141
7.1.2	Functionality.....	141
7.1.3	Function block.....	141
7.1.4	Signals.....	142
7.1.5	Settings.....	142
7.1.6	Monitored data.....	143
7.1.7	Operation principle.....	143
7.1.7.1	Measurement principle.....	144
7.1.7.2	Time delay.....	144
7.1.7.3	Blocking.....	145
7.1.7.4	Design.....	145
7.1.8	Technical data.....	146
7.2	Two step overvoltage protection OV2PTOV	147
7.2.1	Identification.....	147
7.2.2	Functionality.....	147
7.2.3	Function block.....	147
7.2.4	Signals.....	148
7.2.5	Settings.....	148
7.2.6	Monitored data.....	149
7.2.7	Operation principle.....	149
7.2.7.1	Measurement principle.....	150
7.2.7.2	Time delay.....	150
7.2.7.3	Blocking.....	151

7.2.7.4	Design.....	151
7.2.8	Technical data.....	152
7.3	Two step residual overvoltage protection ROV2PTOV	153
7.3.1	Identification.....	153
7.3.2	Functionality.....	153
7.3.3	Function block.....	153
7.3.4	Signals.....	154
7.3.5	Settings.....	154
7.3.6	Monitored data.....	155
7.3.7	Operation principle.....	155
7.3.7.1	Measurement principle.....	155
7.3.7.2	Time delay.....	155
7.3.7.3	Blocking.....	155
7.3.7.4	Design.....	155
7.3.8	Technical data.....	156
7.4	Loss of voltage check LOVPTUV	157
7.4.1	Identification.....	157
7.4.2	Functionality.....	157
7.4.3	Function block.....	157
7.4.4	Signals.....	158
7.4.5	Settings.....	158
7.4.6	Operation principle.....	158
7.4.7	Technical data.....	160
Section 8	Frequency protection.....	161
8.1	Underfrequency protection SAPTUF	161
8.1.1	Identification.....	161
8.1.2	Functionality.....	161
8.1.3	Function block.....	161
8.1.4	Signals.....	161
8.1.5	Settings.....	162
8.1.6	Monitored data.....	162
8.1.7	Operation principle.....	162
8.1.7.1	Measurement principle.....	162
8.1.7.2	Time delay.....	163
8.1.7.3	Blocking.....	163
8.1.7.4	Design.....	163
8.1.8	Technical data.....	164
8.2	Overfrequency protection SAPTOF	164
8.2.1	Identification.....	164
8.2.2	Functionality.....	164
8.2.3	Function block.....	165
8.2.4	Signals.....	165
8.2.5	Settings.....	165
8.2.6	Monitored data.....	165
8.2.7	Operation principle.....	165

8.2.7.1	Measurement principle.....	166
8.2.7.2	Time delay.....	166
8.2.7.3	Blocking.....	166
8.2.7.4	Design.....	167
8.2.8	Technical data.....	167
8.3	Rate-of-change frequency protection SAPFRC	167
8.3.1	Identification.....	168
8.3.2	Functionality.....	168
8.3.3	Function block.....	168
8.3.4	Signals.....	168
8.3.5	Settings.....	169
8.3.6	Operation principle.....	169
8.3.6.1	Measurement principle.....	169
8.3.6.2	Time delay.....	169
8.3.6.3	Design.....	170
8.3.7	Technical data.....	170
Section 9	Secondary system supervision.....	171
9.1	Current circuit supervision CCSRDIF	171
9.1.1	Identification.....	171
9.1.2	Functionality.....	171
9.1.3	Function block.....	171
9.1.4	Signals.....	171
9.1.5	Settings.....	172
9.1.6	Operation principle.....	172
9.1.7	Technical data.....	173
9.2	Fuse failure supervision SDDRFUF.....	174
9.2.1	Identification.....	174
9.2.2	Functionality.....	174
9.2.3	Function block.....	174
9.2.4	Signals.....	175
9.2.5	Settings.....	175
9.2.6	Monitored data.....	176
9.2.7	Operation principle.....	176
9.2.7.1	Zero and negative sequence detection.....	176
9.2.7.2	Delta current and delta voltage detection.....	177
9.2.7.3	Dead line detection.....	179
9.2.7.4	Main logic.....	180
9.2.8	Technical data.....	183
9.3	Breaker close/trip circuit monitoring TCSSCBR.....	183
9.3.1	Identification.....	183
9.3.2	Functionality.....	183
9.3.3	Function block.....	183
9.3.4	Signals.....	184
9.3.5	Settings.....	184
9.3.6	Operation principle.....	184

9.3.7	Technical data.....	185
Section 10	Control.....	187
10.1	Synchrocheck, energizing check, and synchronizing SESRSYN.....	187
10.1.1	Identification.....	187
10.1.2	Functionality.....	187
10.1.3	Function block.....	188
10.1.4	Signals.....	188
10.1.5	Settings.....	190
10.1.6	Monitored data.....	192
10.1.7	Operation principle.....	192
10.1.7.1	Basic functionality.....	192
10.1.7.2	Synchrocheck.....	193
10.1.7.3	Synchronizing.....	194
10.1.7.4	Energizing check.....	195
10.1.7.5	Fuse failure supervision.....	196
10.1.7.6	Voltage selection.....	196
10.1.7.7	Voltage selection for a single circuit breaker with double busbars.....	196
10.1.7.8	Voltage selection for a 1 1/2 circuit breaker arrangement.....	197
10.1.8	Technical data.....	199
10.2	Autorecloser for 3-phase operation SMBRREC	200
10.2.1	Identification.....	200
10.2.2	Functionality.....	200
10.2.3	Function block.....	201
10.2.4	Signals.....	201
10.2.5	Settings.....	202
10.2.6	Operation principle.....	203
10.2.6.1	Start auto-reclosing and conditions for start of a reclosing cycle.....	203
10.2.6.2	Control of the auto-reclosing open time.....	204
10.2.6.3	Long trip signal.....	204
10.2.7	Technical data.....	209
10.3	Apparatus control.....	209
10.3.1	Functionality.....	209
10.3.2	Switch controller SCSWI.....	210
10.3.2.1	Identification	210
10.3.2.2	Functionality.....	210
10.3.2.3	Function block.....	210
10.3.2.4	Signals.....	210
10.3.2.5	Settings.....	211
10.3.3	Circuit breaker SXCBR.....	211
10.3.3.1	Identification	211
10.3.3.2	Functionality.....	211
10.3.3.3	Function block.....	212
10.3.3.4	Signals.....	212
10.3.3.5	Settings.....	213
10.3.4	Circuit switch SXSWI.....	213

10.3.4.1	Identification	213
10.3.4.2	Functionality.....	213
10.3.4.3	Function block.....	214
10.3.4.4	Signals.....	214
10.3.4.5	Settings.....	215
10.3.5	Bay control QCBAY.....	215
10.3.5.1	Identification	215
10.3.5.2	Functionality.....	215
10.3.5.3	Function block.....	215
10.3.5.4	Signals.....	216
10.3.5.5	Settings.....	216
10.3.6	Local remote LOCREM.....	216
10.3.6.1	Identification	216
10.3.6.2	Functionality.....	216
10.3.6.3	Function block.....	217
10.3.6.4	Signals.....	217
10.3.6.5	Settings.....	217
10.3.7	Local remote control LOCREMCTRL.....	217
10.3.7.1	Identification	217
10.3.7.2	Functionality.....	218
10.3.7.3	Function block.....	218
10.3.7.4	Signals.....	218
10.3.7.5	Settings.....	219
10.3.8	Select release SELGGIO.....	219
10.3.8.1	Identification.....	219
10.3.8.2	Function block.....	219
10.3.8.3	Signals.....	220
10.3.8.4	Settings.....	220
10.3.9	Operation principle.....	220
10.3.9.1	Switch controller SCSWI.....	220
10.3.9.2	Circuit breaker SXCBR.....	224
10.3.9.3	Circuit switch SXSWI	228
10.3.9.4	Bay control QCBAY.....	231
10.3.9.5	Local remote/Local remote control LOCREM/LOCREMCTRL.....	233
10.4	Interlocking.....	233
10.4.1	Functionality.....	233
10.4.2	Logical node for interlocking SCILO	234
10.4.2.1	Identification.....	234
10.4.2.2	Functionality.....	234
10.4.2.3	Function block.....	234
10.4.2.4	Logic diagram.....	234
10.4.2.5	Signals.....	235
10.4.2.6	Settings.....	235
10.4.3	Interlocking for busbar earthing switch BB_ES	235
10.4.3.1	Identification.....	235
10.4.3.2	Functionality.....	235

10.4.3.3	Function block.....	236
10.4.3.4	Logic diagram.....	236
10.4.3.5	Signals.....	236
10.4.3.6	Settings.....	236
10.4.4	Interlocking for bus-section breaker A1A2_BS.....	236
10.4.4.1	Identification.....	237
10.4.4.2	Functionality.....	237
10.4.4.3	Function block.....	237
10.4.4.4	Logic diagram.....	238
10.4.4.5	Signals.....	239
10.4.4.6	Settings.....	240
10.4.5	Interlocking for bus-section disconnecter A1A2_DC	240
10.4.5.1	Identification.....	240
10.4.5.2	Functionality.....	240
10.4.5.3	Function block.....	241
10.4.5.4	Logic diagram.....	241
10.4.5.5	Signals.....	242
10.4.5.6	Settings.....	242
10.4.6	Interlocking for bus-coupler bay ABC_BC	242
10.4.6.1	Identification.....	243
10.4.6.2	Functionality.....	243
10.4.6.3	Function block.....	244
10.4.6.4	Logic diagram.....	244
10.4.6.5	Signals.....	247
10.4.6.6	Settings.....	249
10.4.7	Interlocking for 1 1/2 CB BH	249
10.4.7.1	Identification.....	249
10.4.7.2	Functionality.....	249
10.4.7.3	Function block.....	250
10.4.7.4	Logic diagrams.....	252
10.4.7.5	Signals.....	255
10.4.7.6	Settings.....	259
10.4.8	Interlocking for double CB bay DB	260
10.4.8.1	Identification.....	260
10.4.8.2	Functionality.....	260
10.4.8.3	Function block.....	261
10.4.8.4	Logic diagrams.....	262
10.4.8.5	Signals.....	265
10.4.8.6	Settings.....	268
10.4.9	Interlocking for line bay ABC_LINE	268
10.4.9.1	Identification.....	268
10.4.9.2	Functionality.....	268
10.4.9.3	Function block.....	269
10.4.9.4	Logic diagram.....	270
10.4.9.5	Signals.....	275
10.4.9.6	Settings.....	277

10.4.10	Interlocking for transformer bay AB_TRAFO	277
10.4.10.1	Identification.....	277
10.4.10.2	Functionality.....	277
10.4.10.3	Function block.....	278
10.4.10.4	Logic diagram.....	279
10.4.10.5	Signals.....	280
10.4.10.6	Settings.....	282
10.4.11	Position evaluation POS_EVAL.....	282
10.4.11.1	Identification.....	282
10.4.11.2	Functionality.....	282
10.4.11.3	Function block.....	282
10.4.11.4	Logic diagram.....	282
10.4.11.5	Signals.....	283
10.4.11.6	Settings.....	283
10.4.12	Operation principle.....	283
10.5	Logic rotating switch for function selection and LHMI presentation SLGGIO.....	285
10.5.1	Identification.....	285
10.5.2	Functionality.....	286
10.5.3	Function block.....	286
10.5.4	Signals.....	286
10.5.5	Settings.....	287
10.5.6	Monitored data.....	288
10.5.7	Operation principle.....	288
10.6	Selector mini switch VSGGIO.....	288
10.6.1	Identification.....	288
10.6.2	Functionality.....	288
10.6.3	Function block.....	289
10.6.4	Signals.....	289
10.6.5	Settings.....	289
10.6.6	Operation principle.....	290
10.7	IEC 61850 generic communication I/O functions DPGGIO.....	290
10.7.1	Identification.....	290
10.7.2	Functionality.....	291
10.7.3	Function block.....	291
10.7.4	Signals.....	291
10.7.5	Settings.....	291
10.7.6	Operation principle.....	291
10.8	Single point generic control 8 signals SPC8GGIO.....	291
10.8.1	Identification.....	291
10.8.2	Functionality.....	292
10.8.3	Function block.....	292
10.8.4	Signals.....	292
10.8.5	Settings.....	293
10.8.6	Operation principle.....	293
10.9	Automation bits AUTOBITS.....	294
10.9.1	Identification.....	294

10.9.2	Functionality.....	294
10.9.3	Function block.....	294
10.9.4	Signals.....	295
10.9.5	Settings.....	296
10.9.6	Operation principle.....	296
10.10	Function commands for IEC 60870-5-103 I103CMD.....	296
10.10.1	Functionality.....	296
10.10.2	Function block.....	296
10.10.3	Signals.....	296
10.10.4	Settings.....	297
10.11	IED commands for IEC 60870-5-103 I103IEDCMD.....	297
10.11.1	Functionality.....	297
10.11.2	Function block.....	297
10.11.3	Signals.....	297
10.11.4	Settings.....	298
10.12	Function commands user defined for IEC 60870-5-103 I103USRCMD.....	298
10.12.1	Functionality.....	298
10.12.2	Function block.....	298
10.12.3	Signals.....	298
10.12.4	Settings.....	299
10.13	Function commands generic for IEC 60870-5-103 I103GENCMD.....	299
10.13.1	Functionality.....	299
10.13.2	Function block.....	300
10.13.3	Signals.....	300
10.13.4	Settings.....	300
10.14	IED commands with position and select for IEC 60870-5-103 I103POSCMD.....	300
10.14.1	Functionality.....	300
10.14.2	Function block.....	301
10.14.3	Signals.....	301
10.14.4	Settings.....	301
Section 11	Logic.....	303
11.1	Tripping logic common 3-phase output SMPPTRC.....	303
11.1.1	Identification.....	303
11.1.2	Functionality.....	303
11.1.3	Function block.....	303
11.1.4	Signals.....	303
11.1.5	Settings.....	304
11.1.6	Operation principle.....	304
11.1.7	Technical data.....	305
11.2	Trip matrix logic TMAGGIO.....	305
11.2.1	Identification.....	305
11.2.2	Functionality.....	305
11.2.3	Function block.....	306
11.2.4	Signals.....	306
11.2.5	Settings.....	307

11.2.6	Operation principle.....	308
11.3	Configurable logic blocks.....	309
11.3.1	Standard configurable logic blocks.....	309
11.3.1.1	Functionality.....	309
11.3.1.2	OR function block.....	310
11.3.1.3	Inverter function block INVERTER.....	311
11.3.1.4	PULSETIMER function block	312
11.3.1.5	Controllable gate function block GATE.....	313
11.3.1.6	Exclusive OR function block XOR.....	313
11.3.1.7	Loop delay function block LOOPDELAY.....	314
11.3.1.8	Timer function block TIMERSET	315
11.3.1.9	AND function block	316
11.3.1.10	Set-reset memory function block SRMEMORY.....	317
11.3.1.11	Reset-set with memory function block RSMEMORY.....	318
11.3.2	Configurable logic Q/T.....	319
11.3.2.1	Functionality.....	319
11.3.2.2	ORQT function block	319
11.3.2.3	INVERTERQT function block	320
11.3.2.4	Pulse timer function block PULSTIMERQT.....	321
11.3.2.5	XORQT function block.....	322
11.3.2.6	Settable timer function block TIMERSETQT.....	323
11.3.2.7	ANDQT function block	324
11.3.2.8	Set-reset function block SRMEMORYQT.....	325
11.3.2.9	Reset-set function block RSMEMORYQT	326
11.3.2.10	INVALIDQT function block.....	327
11.3.2.11	Indication combining single position function block INDCOMBSPQT.....	329
11.3.2.12	Indication extractor single position function block INDEXTSPQT.....	330
11.3.3	Technical data.....	331
11.4	Fixed signals FXDSIGN.....	331
11.4.1	Identification.....	331
11.4.2	Functionality.....	332
11.4.3	Function block.....	332
11.4.4	Signals.....	332
11.4.5	Settings.....	332
11.4.6	Operation principle.....	332
11.5	Boolean 16 to integer conversion B16I.....	333
11.5.1	Identification.....	333
11.5.2	Functionality.....	333
11.5.3	Function block.....	333
11.5.4	Signals.....	333
11.5.5	Settings.....	334
11.5.6	Monitored data.....	334
11.5.7	Operation principle.....	334
11.6	Boolean 16 to integer conversion with logic node representation B16IFCVI.....	335
11.6.1	Identification.....	335
11.6.2	Functionality.....	335

11.6.3	Function block.....	336
11.6.4	Signals.....	336
11.6.5	Settings.....	337
11.6.6	Monitored data.....	337
11.6.7	Operation principle.....	337
11.7	Integer to boolean 16 conversion IB16A.....	338
11.7.1	Identification.....	338
11.7.2	Functionality.....	338
11.7.3	Function block.....	338
11.7.4	Signals.....	338
11.7.5	Settings.....	339
11.7.6	Operation principle.....	339
11.8	Integer to boolean 16 conversion with logic node representation IB16FCVB.....	340
11.8.1	Identification.....	340
11.8.2	Functionality.....	340
11.8.3	Function block.....	341
11.8.4	Signals.....	341
11.8.5	Settings.....	342
11.8.6	Operation principle.....	342
11.9	Elapsed time integrator with limit transgression and overflow supervision TEIGGIO.....	343
11.9.1	Identification.....	343
11.9.2	Functionality.....	343
11.9.3	Function block.....	343
11.9.4	Signals.....	343
11.9.5	Settings.....	344
11.9.6	Operation principle.....	344
11.9.6.1	Operation Accuracy.....	345
11.9.6.2	Memory storage.....	345
11.9.7	Technical data.....	346
Section 12	Monitoring.....	347
12.1	Measurements.....	347
12.1.1	Functionality.....	347
12.1.2	Measurements CVMMXN.....	348
12.1.2.1	Identification	348
12.1.2.2	Function block.....	348
12.1.2.3	Signals.....	349
12.1.2.4	Settings.....	350
12.1.2.5	Monitored data.....	353
12.1.3	Phase current measurement CMMXU.....	353
12.1.3.1	Identification	353
12.1.3.2	Function block.....	353
12.1.3.3	Signals.....	354
12.1.3.4	Settings.....	354
12.1.3.5	Monitored data.....	355
12.1.4	Phase-phase voltage measurement VMMXU.....	355

12.1.4.1	Identification	355
12.1.4.2	Function block.....	355
12.1.4.3	Signals.....	356
12.1.4.4	Settings.....	356
12.1.4.5	Monitored data.....	357
12.1.5	Current sequence component measurement CMSQI.....	357
12.1.5.1	Identification	357
12.1.5.2	Function block.....	357
12.1.5.3	Signals.....	358
12.1.5.4	Settings.....	358
12.1.5.5	Monitored data.....	360
12.1.6	Voltage sequence measurement VMSQI.....	360
12.1.6.1	Identification	360
12.1.6.2	Function block.....	360
12.1.6.3	Signals.....	360
12.1.6.4	Settings.....	361
12.1.6.5	Monitored data.....	362
12.1.7	Phase-neutral voltage measurement VNMMXU.....	363
12.1.7.1	Identification	363
12.1.7.2	Function block.....	363
12.1.7.3	Signals.....	363
12.1.7.4	Settings.....	364
12.1.7.5	Monitored data.....	364
12.1.8	Operation principle.....	365
12.1.8.1	Measurement supervision.....	365
12.1.8.2	Measurements CVMMXN.....	369
12.1.8.3	Phase current measurement CMMXU.....	373
12.1.8.4	Phase-phase and phase-neutral voltage measurements VMMXU, VNMMXU.....	374
12.1.8.5	Voltage and current sequence measurements VMSQI, CMSQI.....	374
12.1.9	Technical data.....	374
12.2	Event Counter CNTGGIO.....	374
12.2.1	Identification.....	374
12.2.2	Functionality.....	375
12.2.3	Function block.....	375
12.2.4	Signals.....	375
12.2.5	Settings.....	375
12.2.6	Monitored data.....	376
12.2.7	Operation principle.....	376
12.2.7.1	Reporting.....	376
12.2.8	Technical data.....	376
12.3	Function description.....	377
12.3.1	Limit counter L4UFCNT.....	377
12.3.2	Introduction.....	377
12.3.3	Principle of operation.....	377
12.3.3.1	Design.....	377
12.3.3.2	Reporting.....	378

12.3.4	Function block.....	378
12.3.5	Signals.....	379
12.3.6	Settings.....	379
12.3.7	Monitored data.....	379
12.3.8	Technical data.....	380
12.4	Disturbance report.....	380
12.4.1	Functionality.....	380
12.4.2	Disturbance report DRPRDRE.....	380
12.4.2.1	Identification.....	380
12.4.2.2	Function block.....	381
12.4.2.3	Signals.....	381
12.4.2.4	Settings.....	381
12.4.2.5	Monitored data.....	382
12.4.3	Analog input signals AxRADR.....	385
12.4.3.1	Identification.....	385
12.4.3.2	Function block.....	385
12.4.3.3	Signals.....	385
12.4.3.4	Settings.....	386
12.4.4	Analog input signals A4RADR.....	389
12.4.4.1	Identification.....	389
12.4.4.2	Function block.....	390
12.4.4.3	Signals.....	390
12.4.4.4	Settings.....	390
12.4.5	Binary input signals BxRBDR.....	394
12.4.5.1	Identification.....	394
12.4.5.2	Function block.....	394
12.4.5.3	Signals.....	394
12.4.5.4	Settings.....	395
12.4.6	Operation principle.....	400
12.4.6.1	Disturbance information.....	401
12.4.6.2	Indications	401
12.4.6.3	Event recorder	401
12.4.6.4	Event list	401
12.4.6.5	Trip value recorder	402
12.4.6.6	Disturbance recorder	402
12.4.6.7	Time tagging.....	402
12.4.6.8	Recording times.....	402
12.4.6.9	Analog signals.....	403
12.4.6.10	Binary signals.....	404
12.4.6.11	Trigger signals.....	404
12.4.6.12	Post Retrigger.....	405
12.4.7	Technical data.....	405
12.5	Indications.....	406
12.5.1	Functionality.....	406
12.5.2	Function block.....	406
12.5.3	Signals.....	406

12.5.3.1	Input signals.....	406
12.5.4	Operation principle.....	406
12.5.5	Technical data.....	407
12.6	Event recorder	407
12.6.1	Functionality.....	407
12.6.2	Function block.....	408
12.6.3	Signals.....	408
12.6.3.1	Input signals.....	408
12.6.4	Operation principle.....	408
12.6.5	Technical data.....	408
12.7	Event list.....	409
12.7.1	Functionality.....	409
12.7.2	Function block.....	409
12.7.3	Signals.....	409
12.7.3.1	Input signals.....	409
12.7.4	Operation principle.....	409
12.7.5	Technical data.....	409
12.8	Trip value recorder.....	410
12.8.1	Functionality.....	410
12.8.2	Function block.....	410
12.8.3	Signals.....	410
12.8.3.1	Input signals.....	410
12.8.4	Operation principle.....	410
12.8.5	Technical data.....	411
12.9	Disturbance recorder.....	411
12.9.1	Functionality.....	411
12.9.2	Function block.....	411
12.9.3	Signals.....	411
12.9.4	Settings.....	411
12.9.5	Operation principle.....	411
12.9.5.1	Memory and storage.....	412
12.9.6	Technical data.....	413
12.10	IEC 61850 generic communication I/O functions SPGGIO.....	413
12.10.1	Identification.....	413
12.10.2	Functionality.....	413
12.10.3	Function block.....	414
12.10.4	Signals.....	414
12.10.5	Settings.....	414
12.10.6	Operation principle.....	414
12.11	IEC 61850 generic communication I/O functions 16 inputs SP16GGIO.....	414
12.11.1	Identification.....	414
12.11.2	Functionality.....	414
12.11.3	Function block.....	415
12.11.4	Signals.....	415
12.11.5	Settings.....	415
12.11.6	MonitoredData.....	416

12.11.7	Operation principle.....	416
12.12	IEC 61850 generic communication I/O functions MVGGIO.....	417
12.12.1	Identification.....	417
12.12.2	Functionality.....	417
12.12.3	Function block.....	417
12.12.4	Signals.....	417
12.12.5	Settings.....	418
12.12.6	Monitored data.....	418
12.12.7	Operation principle.....	418
12.13	Measured value expander block MVEXP.....	419
12.13.1	Identification.....	419
12.13.2	Functionality.....	419
12.13.3	Function block.....	419
12.13.4	Signals.....	419
12.13.5	Settings.....	420
12.13.6	Operation principle.....	420
12.14	Fault locator LMBRFLO.....	420
12.14.1	Identification.....	420
12.14.2	Functionality.....	420
12.14.3	Function block.....	421
12.14.4	Signals.....	421
12.14.5	Settings.....	422
12.14.6	Monitored data.....	423
12.14.7	Operation principle.....	423
12.14.7.1	Measuring Principle.....	424
12.14.7.2	Accurate algorithm for measurement of distance to fault.....	424
12.14.7.3	The non-compensated impedance model.....	427
12.14.8	Technical data.....	428
12.15	Station battery supervision SPVNZBAT.....	428
12.15.1	Identification.....	428
12.15.2	Function block.....	428
12.15.3	Functionality.....	428
12.15.4	Signals.....	429
12.15.5	Settings.....	429
12.15.6	Measured values.....	429
12.15.7	Monitored Data.....	429
12.15.8	Operation principle	430
12.15.9	Technical data.....	431
12.16	Insulation gas monitoring function SSIMG.....	431
12.16.1	Identification.....	431
12.16.2	Functionality.....	431
12.16.3	Function block.....	431
12.16.4	Signals.....	432
12.16.5	Settings.....	432
12.16.6	Operation principle.....	433
12.16.7	Technical data.....	433

12.17	Insulation liquid monitoring function SSIML.....	433
12.17.1	Identification.....	433
12.17.2	Functionality.....	433
12.17.3	Function block.....	434
12.17.4	Signals.....	434
12.17.5	Settings.....	435
12.17.6	Operation principle.....	435
12.17.7	Technical data.....	435
12.18	Circuit breaker condition monitoring SSCBR.....	436
12.18.1	Identification.....	436
12.18.2	Functionality.....	436
12.18.3	Function block.....	436
12.18.4	Signals.....	437
12.18.5	Settings.....	438
12.18.6	Monitored data.....	439
12.18.7	Operation principle.....	439
12.18.7.1	Circuit breaker status.....	440
12.18.7.2	Circuit breaker operation monitoring.....	441
12.18.7.3	Breaker contact travel time.....	442
12.18.7.4	Operation counter.....	443
12.18.7.5	Accumulation of I ² t.....	443
12.18.7.6	Remaining life of the circuit breaker.....	444
12.18.7.7	Circuit breaker spring charged indication.....	445
12.18.7.8	Gas pressure supervision.....	446
12.18.8	Technical data.....	447
12.19	Measurands for IEC 60870-5-103 I103MEAS.....	447
12.19.1	Functionality.....	447
12.19.2	Function block.....	448
12.19.3	Signals.....	448
12.19.4	Settings.....	449
12.20	Measurands user defined signals for IEC 60870-5-103 I103MEASUSR.....	449
12.20.1	Functionality.....	449
12.20.2	Function block.....	450
12.20.3	Signals.....	450
12.20.4	Settings.....	450
12.21	Function status auto-recloser for IEC 60870-5-103 I103AR.....	451
12.21.1	Functionality.....	451
12.21.2	Function block.....	451
12.21.3	Signals.....	451
12.21.4	Settings.....	451
12.22	Function status earth-fault for IEC 60870-5-103 I103EF.....	452
12.22.1	Functionality.....	452
12.22.2	Function block.....	452
12.22.3	Signals.....	452
12.22.4	Settings.....	452
12.23	Function status fault protection for IEC 60870-5-103 I103FLTPROT.....	452

12.23.1	Functionality.....	452
12.23.2	Function block.....	453
12.23.3	Signals.....	453
12.23.4	Settings.....	454
12.24	IED status for IEC 60870-5-103 I103IED.....	454
12.24.1	Functionality.....	454
12.24.2	Function block.....	454
12.24.3	Signals.....	455
12.24.4	Settings.....	455
12.25	Supervision status for IEC 60870-5-103 I103SUPERV.....	455
12.25.1	Functionality.....	455
12.25.2	Function block.....	455
12.25.3	Signals.....	456
12.25.4	Settings.....	456
12.26	Status for user defined signals for IEC 60870-5-103 I103USRDEF.....	456
12.26.1	Functionality.....	456
12.26.2	Function block.....	457
12.26.3	Signals.....	457
12.26.4	Settings.....	457
Section 13	Metering.....	459
13.1	Pulse counter PCGGIO.....	459
13.1.1	Identification.....	459
13.1.2	Functionality.....	459
13.1.3	Function block.....	459
13.1.4	Signals.....	459
13.1.5	Settings.....	460
13.1.6	Monitored data.....	460
13.1.7	Operation principle.....	460
13.1.8	Technical data.....	462
13.2	Energy calculation and demand handling ETPMMTR.....	462
13.2.1	Identification.....	462
13.2.2	Functionality.....	462
13.2.3	Function block.....	462
13.2.4	Signals.....	463
13.2.5	Settings.....	464
13.2.6	Monitored data.....	465
13.2.7	Operation principle.....	465
13.2.8	Technical data.....	466
Section 14	Station communication.....	467
14.1	DNP3 protocol.....	467
14.2	IEC 61850-8-1 communication protocol	467
14.2.1	Identification.....	467
14.2.2	Functionality.....	467
14.2.3	Communication interfaces and protocols.....	468
14.2.4	Settings.....	468

14.2.5	Technical data.....	468
14.3	Horizontal communication via GOOSE for interlocking.....	469
14.3.1	Identification.....	469
14.3.2	Function block.....	469
14.3.3	Signals.....	470
14.3.4	Settings.....	471
14.4	Goose binary receive GOOSEBINRCV.....	471
14.4.1	Identification.....	471
14.4.2	Function block.....	472
14.4.3	Signals.....	472
14.4.4	Settings.....	473
14.4.5	Operation principle.....	473
14.5	GOOSE function block to receive a double point value GOOSEDPRCV.....	474
14.5.1	Identification.....	474
14.5.2	Functionality.....	474
14.5.3	Function block.....	474
14.5.4	Signals.....	474
14.5.5	Settings.....	475
14.5.6	Operation principle	475
14.6	GOOSE function block to receive an integer value GOOSEINTRCV.....	475
14.6.1	Identification.....	475
14.6.2	Functionality.....	475
14.6.3	Function block.....	476
14.6.4	Signals.....	476
14.6.5	Settings.....	476
14.6.6	Operation principle	476
14.7	GOOSE function block to receive a measurand value GOOSEMVRCV.....	477
14.7.1	Identification.....	477
14.7.2	Functionality.....	477
14.7.3	Function block.....	477
14.7.4	Signals.....	477
14.7.5	Settings.....	478
14.7.6	Operation principle	478
14.8	GOOSE function block to receive a single point value GOOSESRCV.....	478
14.8.1	Identification.....	478
14.8.2	Functionality.....	478
14.8.3	Function block.....	479
14.8.4	Signals.....	479
14.8.5	Settings.....	479
14.8.6	Operation principle	479
14.9	IEC 60870-5-103 communication protocol.....	480
14.9.1	Functionality.....	480
14.9.2	Settings.....	480
14.10	IEC 61850-8-1 redundant station bus communication.....	481
14.10.1	Functionality	481
14.10.2	Principle of operation.....	482

14.10.3	Function block.....	483
14.10.4	Setting parameters.....	483
14.11	Activity logging parameters ACTIVLOG.....	483
14.11.1	Activity logging ACTIVLOG.....	483
14.11.2	Settings.....	483
14.12	Generic security application component AGSAL.....	484
14.12.1	Generic security application AGSAL.....	484
14.13	Security events on protocols SECALARM.....	484
14.13.1	Security alarm SECALARM.....	484
14.13.2	Signals.....	484
14.13.3	Settings.....	485
Section 15	Basic IED functions.....	487
15.1	Self supervision with internal event list	487
15.1.1	Functionality.....	487
15.1.2	Internal error signals INTERRSIG.....	487
15.1.2.1	Identification.....	487
15.1.2.2	Function block.....	487
15.1.2.3	Signals.....	487
15.1.2.4	Settings.....	487
15.1.3	Internal event list SELFSUPEVLST.....	488
15.1.3.1	Identification.....	488
15.1.3.2	Settings.....	488
15.1.4	Operation principle.....	488
15.1.4.1	Internal signals.....	490
15.1.4.2	Run-time model.....	491
15.1.5	Technical data.....	492
15.2	Time synchronization.....	492
15.2.1	Functionality.....	492
15.2.2	Time synchronization TIMESYNCHGEN.....	493
15.2.2.1	Identification.....	493
15.2.2.2	Settings.....	493
15.2.3	Time synchronization via SNTP.....	493
15.2.3.1	Identification.....	493
15.2.3.2	Settings.....	493
15.2.4	Time system, summer time begin DSTBEGIN.....	494
15.2.4.1	Identification.....	494
15.2.4.2	Settings.....	494
15.2.5	Time system, summer time ends DSTEND.....	494
15.2.5.1	Identification.....	494
15.2.5.2	Settings.....	495
15.2.6	Time zone from UTC TIMEZONE.....	495
15.2.6.1	Identification.....	495
15.2.6.2	Settings.....	495
15.2.7	Time synchronization via IRIG-B.....	496
15.2.7.1	Identification.....	496

15.2.7.2	Settings.....	496
15.2.8	Operation principle.....	496
15.2.8.1	General concepts.....	496
15.2.8.2	Real-time clock (RTC) operation.....	497
15.2.8.3	Synchronization alternatives.....	498
15.2.9	Technical data.....	499
15.3	Parameter setting group handling.....	499
15.3.1	Functionality.....	499
15.3.2	Setting group handling SETGRPS.....	499
15.3.2.1	Identification.....	499
15.3.2.2	Settings.....	499
15.3.3	Parameter setting groups ACTVGRP.....	500
15.3.3.1	Identification.....	500
15.3.3.2	Function block.....	500
15.3.3.3	Signals.....	500
15.3.3.4	Settings.....	500
15.3.4	Operation principle.....	501
15.4	Test mode functionality TESTMODE.....	502
15.4.1	Identification.....	502
15.4.2	Functionality.....	502
15.4.3	Function block.....	502
15.4.4	Signals.....	502
15.4.5	Settings.....	503
15.4.6	Operation principle.....	503
15.5	Change lock function CHNGLCK	504
15.5.1	Identification.....	504
15.5.2	Functionality.....	504
15.5.3	Function block.....	504
15.5.4	Signals.....	504
15.5.5	Settings.....	505
15.5.6	Operation principle.....	505
15.6	IED identifiers TERMINALID.....	505
15.6.1	Identification.....	505
15.6.2	Functionality.....	506
15.6.3	Settings.....	506
15.7	Product information	506
15.7.1	Identification.....	506
15.7.2	Functionality.....	506
15.7.3	Settings.....	507
15.8	Primary system values PRIMVAL.....	507
15.8.1	Identification.....	507
15.8.2	Functionality.....	507
15.8.3	Settings.....	507
15.9	Signal matrix for analog inputs SMAI.....	507
15.9.1	Functionality.....	507
15.9.2	Identification.....	508

15.9.3	Function block.....	508
15.9.4	Signals.....	508
15.9.5	Settings.....	510
15.9.6	Operation principle	511
15.10	Summation block 3 phase 3PHSUM.....	514
15.10.1	Identification.....	514
15.10.2	Functionality.....	514
15.10.3	Function block.....	514
15.10.4	Signals.....	515
15.10.5	Settings.....	515
15.10.6	Operation principle.....	515
15.11	Global base values GBASVAL.....	516
15.11.1	Identification.....	516
15.11.2	Functionality.....	516
15.11.3	Settings.....	516
15.12	Authority check ATHCHCK.....	516
15.12.1	Identification.....	516
15.12.2	Functionality.....	516
15.12.3	Settings.....	517
15.12.4	Operation principle.....	517
15.12.4.1	Authorization handling in the IED.....	518
15.13	Authority management AUTHMAN.....	519
15.13.1	Identification.....	519
15.13.2	AUTHMAN.....	519
15.13.3	Settings.....	519
15.14	FTP access with password FTPACCS.....	519
15.14.1	Identification.....	519
15.14.2	FTP access with SSL FTPACCS.....	519
15.14.3	Settings.....	520
15.15	Authority status ATHSTAT.....	520
15.15.1	Identification.....	520
15.15.2	Functionality.....	520
15.15.3	Function block.....	520
15.15.4	Signals.....	521
15.15.5	Settings.....	521
15.15.6	Operation principle.....	521
15.16	Denial of service.....	521
15.16.1	Functionality.....	521
15.16.2	Denial of service, frame rate control for front port DOSFRNT.....	521
15.16.2.1	Identification.....	521
15.16.2.2	Function block.....	522
15.16.2.3	Signals.....	522
15.16.2.4	Settings.....	522
15.16.2.5	Monitored data.....	522
15.16.3	Denial of service, frame rate control for LAN1 port DOSLAN1.....	523
15.16.3.1	Identification.....	523

15.16.3.2	Function block.....	523
15.16.3.3	Signals.....	523
15.16.3.4	Settings.....	523
15.16.3.5	Monitored data.....	523
15.16.4	Operation principle.....	524
Section 16	IED physical connections.....	525
16.1	Protective earth connections.....	525
16.2	Inputs.....	525
16.2.1	Measuring inputs.....	525
16.2.2	Auxiliary supply voltage input.....	526
16.2.3	Binary inputs.....	527
16.3	Outputs.....	530
16.3.1	Outputs for tripping, controlling and signalling.....	530
16.3.2	Outputs for signalling.....	532
16.3.3	IRF.....	534
16.4	Communication connections.....	534
16.4.1	Ethernet RJ-45 front connection.....	534
16.4.2	Station communication rear connection.....	535
16.4.3	Optical serial rear connection.....	535
16.4.4	EIA-485 serial rear connection.....	535
16.4.5	Communication interfaces and protocols.....	535
16.4.6	Recommended industrial Ethernet switches.....	536
16.5	Connection diagrams.....	536
Section 17	Labels.....	537
17.1	Labels on IED.....	537
Section 18	Technical data.....	539
18.1	Dimensions.....	539
18.2	Power supply.....	539
18.3	Energizing inputs.....	539
18.4	Binary inputs.....	540
18.5	Signal outputs.....	541
18.6	Power outputs.....	541
18.7	Data communication interfaces.....	541
18.8	Enclosure class.....	543
18.9	Ingress protection.....	543
18.10	Environmental conditions and tests.....	543
Section 19	IED and functionality tests.....	545
19.1	Electromagnetic compatibility tests.....	545
19.2	Insulation tests.....	546
19.3	Mechanical tests.....	547
19.4	Product safety.....	547
19.5	EMC compliance.....	547
Section 20	Time inverse characteristics.....	549

20.1	Application.....	549
20.2	Operation principle.....	551
20.2.1	Mode of operation.....	551
20.3	Inverse time characteristics.....	554
Section 21	Glossary.....	579

Section 1 Introduction

1.1 This manual

The technical manual contains application and functionality descriptions and lists function blocks, logic diagrams, input and output signals, setting parameters and technical data, sorted per function. The manual can be used as a technical reference during the engineering phase, installation and commissioning phase, and during normal service.

1.2 Intended audience

This manual addresses system engineers and installation and commissioning personnel, who use technical data during engineering, installation and commissioning, and in normal service.

The system engineer must have a thorough knowledge of protection systems, protection equipment, protection functions and the configured functional logic in the IEDs. The installation and commissioning personnel must have a basic knowledge in handling electronic equipment.

1.3 Product documentation

1.3.1 Product documentation set

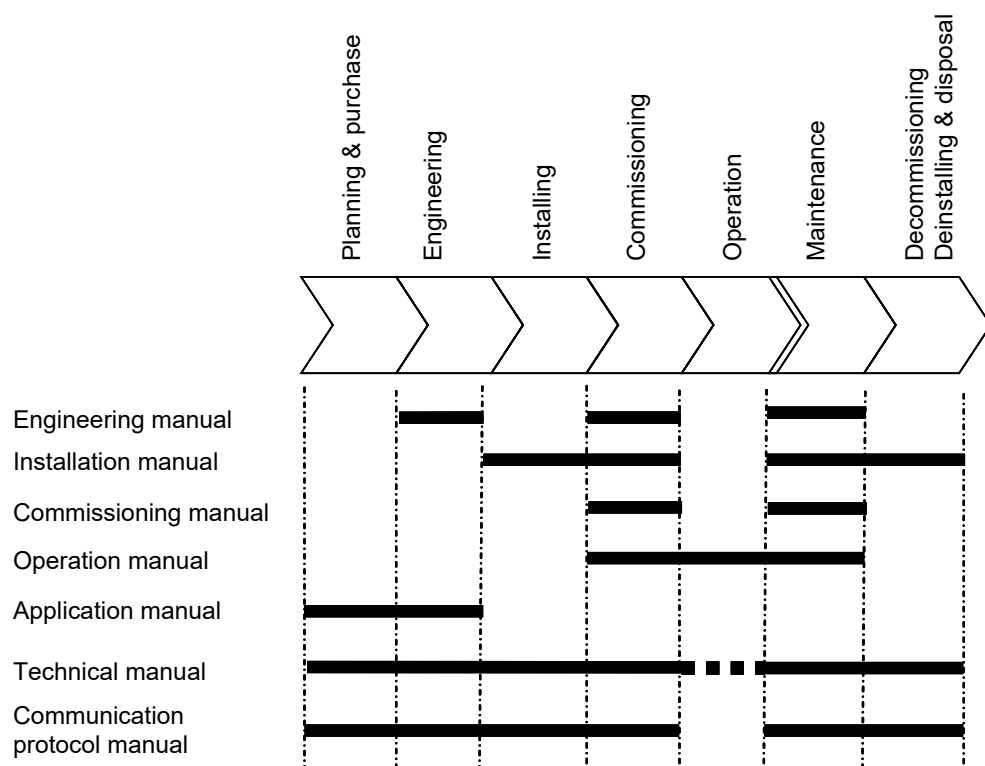

IEC07000220-3-en.vsd

Figure 1: The intended use of manuals throughout the product lifecycle

The engineering manual contains instructions on how to engineer the IEDs using the various tools available within the PCM600 software. The manual provides instructions on how to set up a PCM600 project and insert IEDs to the project structure. The manual also recommends a sequence for the engineering of protection and control functions, LHMI functions as well as communication engineering for IEC 60870-5-103, IEC 61850 and DNP 3.0.

The installation manual contains instructions on how to install the IED. The manual provides procedures for mechanical and electrical installation. The chapters are organized in the chronological order in which the IED should be installed.

The commissioning manual contains instructions on how to commission the IED. The manual can also be used by system engineers and maintenance personnel for assistance during the testing phase. The manual provides procedures for the checking of external circuitry and energizing the IED, parameter setting and configuration as well as verifying settings by secondary injection. The manual describes the process of testing an IED in a substation which is not in service. The chapters are organized in the chronological order in which the IED should be commissioned. The relevant procedures may be followed also during the service and maintenance activities.

The operation manual contains instructions on how to operate the IED once it has been commissioned. The manual provides instructions for the monitoring, controlling and setting of the IED. The manual also describes how to identify disturbances and how to view calculated and measured power grid data to determine the cause of a fault.

The application manual contains application descriptions and setting guidelines sorted per function. The manual can be used to find out when and for what purpose a typical protection function can be used. The manual can also provides assistance for calculating settings.

The technical manual contains application and functionality descriptions and lists function blocks, logic diagrams, input and output signals, setting parameters and technical data, sorted per function. The manual can be used as a technical reference during the engineering phase, installation and commissioning phase, and during normal service.

The communication protocol manual describes the communication protocols supported by the IED. The manual concentrates on the vendor-specific implementations.

The point list manual describes the outlook and properties of the data points specific to the IED. The manual should be used in conjunction with the corresponding communication protocol manual.

1.3.2 Document revision history

Document revision/date	History
-/March 2013	First release
A/October 2016	Minor corrections made
B/November 2019	Maintenance release - Updated safety information and bug corrections

1.3.3 Related documents

Documents related to REC650	Identity number
Application manual	1MRK 511 286-UEN
Technical manual	1MRK 511 287-UEN
Commissioning manual	1MRK 511 288-UEN
Product Guide	1MRK 511 289-BEN
Type test certificate	1MRK 511 289-TEN

650 series manuals	Identity number
Communication protocol manual, DNP 3.0	1MRK 511 280-UEN
Communication protocol manual, IEC 61850–8–1	1MRK 511 281-UEN
Communication protocol manual, IEC 60870-5-103	1MRK 511 282-UEN
Cyber Security deployment guidelines	1MRK 511 285-UEN
Point list manual, DNP 3.0	1MRK 511 283-UEN
Engineering manual	1MRK 511 284-UEN
Operation manual	1MRK 500 096-UEN
Installation manual	1MRK 514 016-UEN
Accessories, 650 series	1MRK 513 023-BEN
MICS	1MRG 010 656
PICS	1MRG 010 660
PIXIT	1MRG 010 658

1.4 Symbols and conventions

1.4.1 Symbols



The electrical warning icon indicates the presence of a hazard which could result in electrical shock.



The warning icon indicates the presence of a hazard which could result in personal injury.



The caution icon indicates important information or warning related to the concept discussed in the text. It might indicate the presence of a hazard which could result in corruption of software or damage to equipment or property.





The information icon alerts the reader of important facts and conditions.



The tip icon indicates advice on, for example, how to design your project or how to use a certain function.

Although warning hazards are related to personal injury, it is necessary to understand that under certain operational conditions, operation of damaged equipment may result in degraded process performance leading to personal injury or death. It is important that the user fully complies with all warning and cautionary notices.

1.4.2 Document conventions

- Abbreviations and acronyms in this manual are spelled out in the glossary. The glossary also contains definitions of important terms.
- Push button navigation in the LHMI menu structure is presented by using the push button icons.
For example, to navigate between the options, use  and .
- HMI menu paths are presented in bold.
For example, select **Main menu/Settings**.
- LHMI messages are shown in Courier font.
For example, to save the changes in non-volatile memory, select Yes and press .
- Parameter names are shown in italics.
For example, the function can be enabled and disabled with the *Operation* setting.
- Each function block symbol shows the available input/output signal.
 - the character ^ in front of an input/output signal name indicates that the signal name may be customized using the PCM600 software.
 - the character * after an input/output signal name indicates that the signal must be connected to another function block in the application configuration to achieve a valid application configuration.

Section 2 Available functions

2.1 Control and monitoring functions

IEC 61850 or Function name	ANSI	Function description	Bay			
			REC650	REC650 (A01) 3Ph/1CBA	REC650 (A02) 3Ph/1CBAB	REC650 (A07) BCAB
Control						
SESRSYN	25	Synchrocheck, energizing check, and synchronizing	0–1	1	1	1
SMBRREC	79	Autorecloser for 3-phase operation	0–1	1	1	1
SLGGIO		Logic Rotating Switch for function selection and LHMI presentation	15	15	15	15
VSGGIO		Selector mini switch	20	20	20	20
DPGGIO		IEC 61850 generic communication I/O functions double point	16	16	16	16
SPC8GGIO		Single point generic control 8 signals	5	5	5	5
AUTOBITS		AutomationBits, command function for DNP3.0	3	3	3	3
I103CMD		Function commands for IEC60870-5-103	1	1	1	1
I103IEDCMD		IED commands for IEC60870-5-103	1	1	1	1
I103USRCMD		Function commands user defined for IEC60870-5-103	4	4	4	4
I103GENCMD		Function commands generic for IEC60870-5-103	50	50	50	50
I103POSCMD		IED commands with position and select for IEC60870-5-103	50	50	50	50
Apparatus control and Interlocking						
APC8		Apparatus control for single bay, max 8 app. (1CB) incl. interlocking	1	1	1	1
SCILO	3	Logical node for interlocking	8	8	8	8
BB_ES	3	Interlocking for busbar earthing switch	3	3	3	3
A1A2_BS	3	Interlocking for bus-section breaker	2	2	2	2
A1A2_DC	3	Interlocking for bus-section disconnect	3	3	3	3
ABC_BC	3	Interlocking for bus-coupler bay	1	1	1	1
BH_CONN	3	Interlocking for 1 1/2 breaker diameter	1	1	1	1
BH_LINE_A	3	Interlocking for 1 1/2 breaker diameter	1	1	1	1
BH_LINE_B	3	Interlocking for 1 1/2 breaker diameter	1	1	1	1
DB_BUS_A	3	Interlocking for double CB bay	1	1	1	1
DB_BUS_B	3	Interlocking for double CB bay	1	1	1	1
DB_LINE	3	Interlocking for double CB bay	1	1	1	1
ABC_LINE	3	Interlocking for line bay	1	1	1	1

Table continues on next page

IEC 61850 or Function name	ANSI	Function description	Bay			
			REC650	REC650 (A01) 3Ph/1CBA	REC650 (A02) 3Ph/1CBAB	REC650 (A07) BCAB
AB_TRAFO	3	Interlocking for transformer bay	1	1	1	1
SCSWI		Switch controller	8	8	8	8
SXCBR		Circuit breaker	3	3	3	3
SXSWI		Circuit switch	7	7	7	7
POS_EVAL		Evaluation of position indication	8	8	8	8
SELGGIO		Select release	1	1	1	1
QCBAY		Bay control	1	1	1	1
LOCREM		Handling of LR-switch positions	1	1	1	1
LOCREMCTRL		LHMI control of Permitted Source To Operate (PSTO)	1	1	1	1
Secondary system supervision						
CCSRDIF	87	Current circuit supervision	0–1	1	1	1
SDDRFUF		Fuse failure supervision	0–1	1	1	1
TCSSCBR		Breaker close/trip circuit monitoring	3	3	3	3
Logic						
SMPPTRC	94	Tripping logic, common 3–phase output	1	1	1	1
TMAGGIO		Trip matrix logic	12	12	12	12
OR		Configurable logic blocks	283	283	283	283
INVERTER		Configurable logic blocks	140	140	140	140
PULSETIMER		Configurable logic blocks	40	40	40	40
GATE		Configurable logic blocks	40	40	40	40
XOR		Configurable logic blocks	40	40	40	40
LOOPDELAY		Configurable logic blocks	40	40	40	40
TIMERSET		Configurable logic blocks	40	40	40	40
AND		Configurable logic blocks	280	280	280	280
SRMEMORY		Configurable logic blocks	40	40	40	40
RSMEMORY		Configurable logic blocks	40	40	40	40
Q/T		Configurable logic blocks Q/T	0–1			
ANDQT		Configurable logic blocks Q/T	0–120	120	120	120
ORQT		Configurable logic blocks Q/T	0–120	120	120	120
INVERTERQT		Configurable logic blocks Q/T	0–120	120	120	120
XORQT		Configurable logic blocks Q/T	0–40	40	40	40
SRMEMORYQT		Configurable logic blocks Q/T	0–40	40	40	40
RSMEMORYQT		Configurable logic blocks Q/T	0–40	40	40	40
TIMERSETQT		Configurable logic blocks Q/T	0–40	40	40	40
PULSETIMERQT		Configurable logic blocks Q/T	0–40	40	40	40
INVALIDQT		Configurable logic blocks Q/T	0–12	12	12	12
INDCOMBSPQT		Configurable logic blocks Q/T	0–20	20	20	20

Table continues on next page

IEC 61850 or Function name	ANSI	Function description	Bay			
			REC650	REC650 (A01) 3Ph/1CBA	REC650 (A02) 3Ph/1CBAB	REC650 (A07) BCAB
INDEXTSPQT		Configurable logic blocks Q/T	0–20	20	20	20
FXDSIGN		Fixed signal function block	1	1	1	1
B16I		Boolean 16 to Integer conversion	16	16	16	16
B16FCVI		Boolean 16 to Integer conversion with logic node representation	16	16	16	16
IB16A		Integer to Boolean 16 conversion	16	16	16	16
IB16FCVB		Integer to Boolean 16 conversion with logic node representation	16	16	16	16
TEIGGIO		Elapsed time integrator with limit transgression and overflow supervision	12	12	12	12
Monitoring						
CVMMXN		Measurements	6	6	6	6
CMMXU		Phase current measurement	10	10	10	10
VMMXU		Phase-phase voltage measurement	6	6	6	6
CMSQI		Current sequence component measurement	6	6	6	6
VMSQI		Voltage sequence measurement	6	6	6	6
VNMMXU		Phase-neutral voltage measurement	6	6	6	6
AISVBAS		Function block for service values presentation of the analog inputs	1	1	1	1
TM_P_P2		Function block for service values presentation of primary analog inputs 600TRM	1	1	1	1
AM_P_P4		Function block for service values presentation of primary analog inputs 600AIM	1	1	1	1
TM_S_P2		Function block for service values presentation of secondary analog inputs 600TRM	1	1	1	1
AM_S_P4		Function block for service values presentation of secondary analog inputs 600AIM	1	1	1	1
CNTGGIO		Event counter	5	5	5	5
L4UFCNT		Event counter with limit supervision	12	12	12	12
DRPRDRE		Disturbance report	1	1	1	1
AnRADR		Analog input signals	4	4	4	4
BnRBDR		Binary input signals	6	6	6	6
SPGGIO		IEC 61850 generic communication I/O functions	64	64	64	64
SP16GGIO		IEC 61850 generic communication I/O functions 16 inputs	16	16	16	16
MVGGIO		IEC 61850 generic communication I/O functions	16	16	16	16
MVEXP		Measured value expander block	66	66	66	66

Table continues on next page

IEC 61850 or Function name	ANSI	Function description	Bay			
			REC650	REC650 (A01) 3Ph/1CBA	REC650 (A02) 3Ph/1CBAB	REC650 (A07) BCAB
LMBRFLO		Fault locator	0-1	1	1	
SPVNZBAT		Station battery supervision	0-1	1	1	1
SSIMG	63	Insulation gas monitoring function	0-1	1	1	1
SSIML	71	Insulation liquid monitoring function	0-1	1	1	1
SSCBR		Circuit breaker condition monitoring	0-1	1	1	1
I103MEAS		Measurands for IEC60870-5-103	1	1	1	1
I103MEASUSR		Measurands user defined signals for IEC60870-5-103	3	3	3	3
I103AR		Function status auto-recloser for IEC60870-5-103	1	1	1	1
I103EF		Function status earth-fault for IEC60870-5-103	1	1	1	1
I103FLTPROT		Function status fault protection for IEC60870-5-103	1	1	1	1
I103IED		IED status for IEC60870-5-103	1	1	1	1
I103SUPERV		Supervision status for IEC60870-5-103	1	1	1	1
I103USRDEF		Status for user defined signals for IEC60870-5-103	20	20	20	20
Metering						
PCGGIO		Pulse counter	16	16	16	16
ETPMTR		Function for energy calculation and demand handling	3	3	3	3

2.2 Back-up protection functions

IEC 61850 or Function name	ANSI	Function description	Bay			
			REC650	REC650 (A01) 3Ph/1CBA	REC650 (A02) 3Ph/1CBAB	REC650 (A07) BCAB
Current protection						
PHPIOC	50	Instantaneous phase overcurrent protection, 3-phase output	0-1	1	1	1
OC4PTOC	51/67	Four step phase overcurrent protection, 3-phase output	0-1	1	1	1
EFPIOC	50N	Instantaneous residual overcurrent protection	0-1	1	1	1
EF4PTOC	51N/67 N	Four step residual overcurrent protection, zero/negative sequence direction	0-1	1	1	1
SDEPSDE	67N	Sensitive directional residual overcurrent and power protection	0-1	1	1	1

Table continues on next page

IEC 61850 or Function name	ANSI	Function description	Bay			
			REC650	REC650 (A01) 3Ph/1CBA	REC650 (A02) 3Ph/1CBAB	REC650 (A07) BCAB
LCPTTR	26	Thermal overload protection, one time constant, Celsius	0–1	1	1	1
LFPTTR	26	Thermal overload protection, one time constant, Fahrenheit	0–1	1	1	1
CCRBRF	50BF	Breaker failure protection, 3–phase activation and output	0–1	1	1	1
STBPTOC	50STB	Stub protection	0–1	1	1	1
CCRPLD	52PD	Pole discordance protection	0–1	1	1	1
BRCPTOC	46	Broken conductor check	0–1	1	1	1
GUPPDUP	37	Directional underpower protection	0–1	1	1	1
GOPPDOP	32	Directional overpower protection	0–1	1	1	1
DNSPTOC	46	Negative sequence based overcurrent function	0–1	1	1	1
Voltage protection						
UV2PTUV	27	Two step undervoltage protection	0–1	1	1	1
OV2PTOV	59	Two step overvoltage protection	0–1	1	1	1
ROV2PTOV	59N	Two step residual overvoltage protection	0–1	1	1	1
LOVPTUV	27	Loss of voltage check	0–1	1	1	1
Frequency protection						
SAPTUF	81	Underfrequency function	0–2	2	2	2
SAPTOF	81	Overfrequency function	0–2	2	2	2
SAPFRC	81	Rate-of-change frequency protection	0–2	2	2	2

2.3 Station communication

IEC 61850 or Function name	ANSI	Function description	Bay			
			REC650	REC650 (A01) 3Ph/1CBA	REC650 (A02) 3Ph/1CBAB	REC650 (A07) BCAB
Station communication						
IEC61850-8-1		IEC 61850 communication protocol	1	1	1	1
DNPGEN		DNP3.0 communication general protocol	1	1	1	1
RS485DNP		DNP3.0 for RS-485 communication protocol	1	1	1	1
CH1TCP		DNP3.0 for TCP/IP communication protocol	1	1	1	1
CH2TCP		DNP3.0 for TCP/IP communication protocol	1	1	1	1

Table continues on next page

IEC 61850 or Function name	ANSI	Function description	Bay			
			REC650	REC650 (A01) 3Ph/1CBA	REC650 (A02) 3Ph/1CBAB	REC650 (A07) BCAB
CH3TCP		DNP3.0 for TCP/IP communication protocol	1	1	1	1
CH4TCP		DNP3.0 for TCP/IP communication protocol	1	1	1	1
OPTICALDNP		DNP3.0 for optical RS-232 communication protocol	1	1	1	1
MSTSERIAL		DNP3.0 for serial communication protocol	1	1	1	1
MST1TCP		DNP3.0 for TCP/IP communication protocol	1	1	1	1
MST2TCP		DNP3.0 for TCP/IP communication protocol	1	1	1	1
MST3TCP		DNP3.0 for TCP/IP communication protocol	1	1	1	1
MST4TCP		DNP3.0 for TCP/IP communication protocol	1	1	1	1
RS485GEN		RS485	1	1	1	1
OPTICALPROT		Operation selection for optical serial	1	1	1	1
RS485PROT		Operation selection for RS485	1	1	1	1
DNPFREC		DNP3.0 fault records for TCP/IP communication protocol	1	1	1	1
OPTICAL103		IEC60870-5-103 Optical serial communication	1	1	1	1
RS485103		IEC60870-5-103 serial communication for RS485	1	1	1	1
GOOSEINTLKRCV		Horizontal communication via GOOSE for interlocking	59	59	59	59
GOOSEBINRCV		GOOSE binary receive	4	4	4	4
ETHFRNT ETHLAN1 GATEWAY		Ethernet configuration of front port, LAN1 port and gateway	1	1	1	1
ETHLAN1_AB		Ethernet configuration of LAN1 port	1			
PRPSTATUS		System component for parallel redundancy protocol	1			
CONFPROT		IED Configuration Protocol	1	1	1	1
ACTIVLOG		Activity logging parameters	1	1	1	1
SECALARM		Component for mapping security events on protocols such as DNP3 and IEC103	1	1	1	1
AGSAL		Generic security application component	1	1	1	1
GOOSEDPKCV		GOOSE function block to receive a double point value	32	32	32	32

Table continues on next page

IEC 61850 or Function name	ANSI	Function description	Bay			
			REC650	REC650 (A01) 3Ph/1CBA	REC650 (A02) 3Ph/1CBAB	REC650 (A07) BCAB
GOOSEINTRCV		GOOSE function block to receive an integer value	32	32	32	32
GOOSEMVRVCV		GOOSE function block to receive a measurand value	16	16	16	16
GOOSESPRCV		GOOSE function block to receive a single point value	64	64	64	64

2.4 Basic IED functions

IEC 61850/Function block name	Function description	
Basic functions included in all products		
INTERRSIG	Self supervision with internal event list	1
SELSUPEVLST	Self supervision with internal event list	1
TIMESYNCHGEN	Time synchronization	1
SNTP	Time synchronization	1
DTSBEGIN, DTSEND, TIMEZONE	Time synchronization, daylight saving	1
IRIG-B	Time synchronization	1
SETGRPS	Setting group handling	1
ACTVGRP	Parameter setting groups	1
TESTMODE	Test mode functionality	1
CHNGLCK	Change lock function	1
PRIMVAL	Primary system values	1
SMAI_20_1 - SMAI_20_12	Signal matrix for analog inputs	2
3PHSUM	Summation block 3 phase	12
GBASVAL	Global base values for settings	6
ATHSTAT	Authority status	1
ATHCHCK	Authority check	1
AUTHMAN	Authority management	1
FTPACCS	FTPS access with password	1
DOSFRNT	Denial of service, frame rate control for front port	1
DOSLAN1	Denial of service, frame rate control for LAN1A and LAN1B ports	1
DOSSCKT	Denial of service, socket flow control	1

Section 3 Analog inputs

3.1 Introduction

Analog input channels in the IED must be set properly in order to get correct measurement results and correct protection operations. For power measuring and all directional and differential functions the directions of the input currents must be defined in order to reflect the way the current transformers are installed/connected in the field (primary and secondary connections). Measuring and protection algorithms in the IED use primary system quantities. Consequently the setting values are expressed in primary quantities as well and therefore it is important to set the transformation ratio of the connected current and voltage transformers properly.

The availability of CT and VT inputs, as well as setting parameters depends on the ordered IED.

A reference *PhaseAngleRef* must be defined to facilitate service values reading. This analog channels phase angle will always be fixed to zero degrees and all other angle information will be shown in relation to this analog input. During testing and commissioning of the IED the reference channel can be changed to facilitate testing and service values reading.

3.2 Operation principle

The direction of a current depends on the connection of the CT. The main CTs are typically star connected and can be connected with the star point towards the object or away from the object. This information must be set in the IED.

The convention of the directionality is defined as follows:

- Positive value of current or power means that the quantity has the direction into the object.
- Negative value of current or power means that the quantity has the direction out from the object.

For directional functions the directional conventions are defined as follows (see figure 2)

- *Forward* means the direction is into the object.
- *Reverse* means the direction is out from the object.

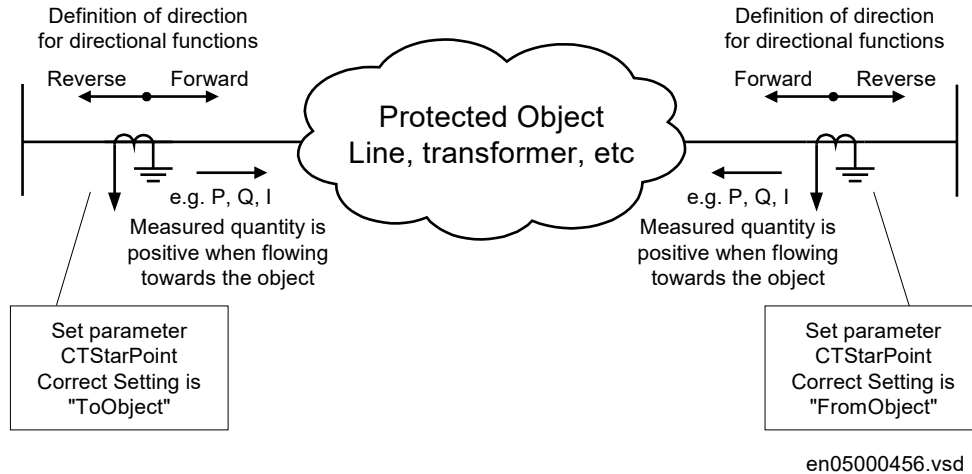

Figure 2: Internal convention of the directionality in the IED

If the settings of the primary CT is correct, that is *CTStarPoint* set as *FromObject* or *ToObject* according to the plant condition, then a positive quantity always flows towards the protected object, and a *Forward* direction always looks towards the protected object.

The settings of the IED is performed in primary values. The ratios of the main CTs and VTs are therefore basic data for the IED. The user has to set the rated secondary and primary currents and voltages of the CTs and VTs to provide the IED with their rated ratios.

The CT and VT ratio and the name on respective channel is done under **Main menu/Hardware/Analog modules** in the Parameter Settings tool or on the HMI.

3.3 Presumptions for technical data

The technical data stated in this document are only valid under the following circumstances:

- CT and VT ratios in the IED are set in accordance with the associated main instrument transformers. Note that for functions which measure an analogue signal which do not have corresponding primary quantity, the 1:1 ratio shall be set for the used analogue inputs on the IED, For example, HZPDIF.
- Parameter *IBase* used by the tested function is set equal to the rated CT primary current.
- Parameter *UBase* used by the tested function is set equal to the rated primary phase-to-phase voltage.
- Parameter *SBase* used by the tested function is set equal to $\sqrt{3} \cdot I_{Base} \cdot U_{Base}$ for three-phase power system.

3.4 Settings

Dependent on ordered IED type.

Table 1: AISVBAS Non group settings (basic)

Name	Values (Range)	Unit	Step	Default	Description
PhaseAngleRef	TRM - Channel 1 TRM - Channel 2 TRM - Channel 3 TRM - Channel 4 TRM - Channel 5 TRM - Channel 6 TRM - Channel 7 TRM - Channel 8 TRM - Channel 9 TRM - Channel 10 AIM - Channel 1 AIM - Channel 2 AIM - Channel 3 AIM - Channel 4 AIM - Channel 5 AIM - Channel 6 AIM - Channel 7 AIM - Channel 8 AIM - Channel 9 AIM - Channel 10	-	-	TRM - Channel 1	Reference channel for phase angle presentation

Table 2: TRM_6I_4U Non group settings (basic)

Name	Values (Range)	Unit	Step	Default	Description
CTStarPoint1	FromObject ToObject	-	-	ToObject	ToObject= towards protected object, FromObject= the opposite
CTsec1	0.1 - 10.0	A	0.1	1	Rated CT secondary current
CTprim1	1 - 99999	A	1	1000	Rated CT primary current
CTStarPoint2	FromObject ToObject	-	-	ToObject	ToObject= towards protected object, FromObject= the opposite
CTsec2	0.1 - 10.0	A	0.1	1.0	Rated CT secondary current
CTprim2	1 - 99999	A	1	1000	Rated CT primary current
CTStarPoint3	FromObject ToObject	-	-	ToObject	ToObject= towards protected object, FromObject= the opposite
CTsec3	0.1 - 10.0	A	0.1	1	Rated CT secondary current
CTprim3	1 - 99999	A	1	1000	Rated CT primary current
CTStarPoint4	FromObject ToObject	-	-	ToObject	ToObject= towards protected object, FromObject= the opposite
CTsec4	0.1 - 10.0	A	0.1	1.0	Rated CT secondary current
CTprim4	1 - 99999	A	1	1000	Rated CT primary current
CTStarPoint5	FromObject ToObject	-	-	ToObject	ToObject= towards protected object, FromObject= the opposite
CTsec5	0.1 - 10.0	A	0.1	1	Rated CT secondary current
CTprim5	1 - 99999	A	1	1000	Rated CT primary current
CTStarPoint6	FromObject ToObject	-	-	ToObject	ToObject= towards protected object, FromObject= the opposite
CTsec6	0.1 - 10.0	A	0.1	1.0	Rated CT secondary current
CTprim6	1 - 99999	A	1	1000	Rated CT primary current
VTsec7	0.001 - 999.999	V	0.001	110.000	Rated VT secondary voltage
VTprim7	0.001 - 9999.999	kV	0.001	132.000	Rated VT primary voltage

Table continues on next page

Name	Values (Range)	Unit	Step	Default	Description
VTsec8	0.001 - 999.999	V	0.001	110	Rated VT secondary voltage
VTprim8	0.001 - 9999.999	kV	0.001	132	Rated VT primary voltage
VTsec9	0.001 - 999.999	V	0.001	110.000	Rated VT secondary voltage
VTprim9	0.001 - 9999.999	kV	0.001	132.000	Rated VT primary voltage
VTsec10	0.001 - 999.999	V	0.001	110	Rated VT secondary voltage
VTprim10	0.001 - 9999.999	kV	0.001	132	Rated VT primary voltage

Table 3: TRM_8I_2U Non group settings (basic)

Name	Values (Range)	Unit	Step	Default	Description
CTStarPoint1	FromObject ToObject	-	-	ToObject	ToObject= towards protected object, FromObject= the opposite
CTsec1	0.1 - 10.0	A	0.1	1	Rated CT secondary current
CTprim1	1 - 99999	A	1	1000	Rated CT primary current
CTStarPoint2	FromObject ToObject	-	-	ToObject	ToObject= towards protected object, FromObject= the opposite
CTsec2	0.1 - 10.0	A	0.1	1.0	Rated CT secondary current
CTprim2	1 - 99999	A	1	1000	Rated CT primary current
CTStarPoint3	FromObject ToObject	-	-	ToObject	ToObject= towards protected object, FromObject= the opposite
CTsec3	0.1 - 10.0	A	0.1	1	Rated CT secondary current
CTprim3	1 - 99999	A	1	1000	Rated CT primary current
CTStarPoint4	FromObject ToObject	-	-	ToObject	ToObject= towards protected object, FromObject= the opposite
CTsec4	0.1 - 10.0	A	0.1	1.0	Rated CT secondary current
CTprim4	1 - 99999	A	1	1000	Rated CT primary current
CTStarPoint5	FromObject ToObject	-	-	ToObject	ToObject= towards protected object, FromObject= the opposite
CTsec5	0.1 - 10.0	A	0.1	1	Rated CT secondary current
CTprim5	1 - 99999	A	1	1000	Rated CT primary current
CTStarPoint6	FromObject ToObject	-	-	ToObject	ToObject= towards protected object, FromObject= the opposite
CTsec6	0.1 - 10.0	A	0.1	1.0	Rated CT secondary current
CTprim6	1 - 99999	A	1	1000	Rated CT primary current
CTStarPoint7	FromObject ToObject	-	-	ToObject	ToObject= towards protected object, FromObject= the opposite
CTsec7	0.1 - 10.0	A	0.1	1	Rated CT secondary current
CTprim7	1 - 99999	A	1	1000	Rated CT primary current
CTStarPoint8	FromObject ToObject	-	-	ToObject	ToObject= towards protected object, FromObject= the opposite
CTsec8	0.1 - 10.0	A	0.1	1.0	Rated CT secondary current
CTprim8	1 - 99999	A	1	1000	Rated CT primary current
VTsec9	0.001 - 999.999	V	0.001	110.000	Rated VT secondary voltage
VTprim9	0.001 - 9999.999	kV	0.001	132.000	Rated VT primary voltage
VTsec10	0.001 - 999.999	V	0.001	110	Rated VT secondary voltage
VTprim10	0.001 - 9999.999	kV	0.001	132	Rated VT primary voltage

Table 4: TRM_4I_1L_5U Non group settings (basic)

Name	Values (Range)	Unit	Step	Default	Description
CTStarPoint1	FromObject ToObject	-	-	ToObject	ToObject= towards protected object, FromObject= the opposite
CTsec1	0.1 - 10.0	A	0.1	1.0	Rated CT secondary current
CTprim1	1 - 99999	A	1	1000	Rated CT primary current
CTStarPoint2	FromObject ToObject	-	-	ToObject	ToObject= towards protected object, FromObject= the opposite
CTsec2	0.1 - 10.0	A	0.1	1.0	Rated CT secondary current
CTprim2	1 - 99999	A	1	1000	Rated CT primary current
CTStarPoint3	FromObject ToObject	-	-	ToObject	ToObject= towards protected object, FromObject= the opposite
CTsec3	0.1 - 10.0	A	0.1	1.0	Rated CT secondary current
CTprim3	1 - 99999	A	1	1000	Rated CT primary current
CTStarPoint4	FromObject ToObject	-	-	ToObject	ToObject= towards protected object, FromObject= the opposite
CTsec4	0.1 - 10.0	A	0.1	1.0	Rated CT secondary current
CTprim4	1 - 99999	A	1	1000	Rated CT primary current
CTStarPoint5	FromObject ToObject	-	-	ToObject	ToObject= towards protected object, FromObject= the opposite
CTsec5	0.1 - 10.0	A	0.1	1.0	Rated CT secondary current
CTprim5	1 - 99999	A	1	1000	Rated CT primary current
VTsec6	0.001 - 999.999	V	0.001	110	Rated VT secondary voltage
VTprim6	0.001 - 9999.999	kV	0.001	132	Rated VT primary voltage
VTsec7	0.001 - 999.999	V	0.001	110.000	Rated VT secondary voltage
VTprim7	0.001 - 9999.999	kV	0.001	132.000	Rated VT primary voltage
VTsec8	0.001 - 999.999	V	0.001	110	Rated VT secondary voltage
VTprim8	0.001 - 9999.999	kV	0.001	132	Rated VT primary voltage
VTsec9	0.001 - 999.999	V	0.001	110.000	Rated VT secondary voltage
VTprim9	0.001 - 9999.999	kV	0.001	132.000	Rated VT primary voltage
VTsec10	0.001 - 999.999	V	0.001	110.000	Rated VT secondary voltage
VTprim10	0.001 - 9999.999	kV	0.001	132.000	Rated VT primary voltage

Table 5: TRM_4I_6U Non group settings (basic)

Name	Values (Range)	Unit	Step	Default	Description
CTStarPoint1	FromObject ToObject	-	-	ToObject	ToObject= towards protected object, FromObject= the opposite
CTsec1	0.1 - 10.0	A	0.1	1	Rated CT secondary current
CTprim1	1 - 99999	A	1	1000	Rated CT primary current
CTStarPoint2	FromObject ToObject	-	-	ToObject	ToObject= towards protected object, FromObject= the opposite
CTsec2	0.1 - 10.0	A	0.1	1.0	Rated CT secondary current
CTprim2	1 - 99999	A	1	1000	Rated CT primary current

Table continues on next page

Name	Values (Range)	Unit	Step	Default	Description
CTStarPoint3	FromObject ToObject	-	-	ToObject	ToObject= towards protected object, FromObject= the opposite
CTsec3	0.1 - 10.0	A	0.1	1	Rated CT secondary current
CTprim3	1 - 99999	A	1	1000	Rated CT primary current
CTStarPoint4	FromObject ToObject	-	-	ToObject	ToObject= towards protected object, FromObject= the opposite
CTsec4	0.1 - 10.0	A	0.1	1.0	Rated CT secondary current
CTprim4	1 - 99999	A	1	1000	Rated CT primary current
VTsec5	0.001 - 999.999	V	0.001	110.000	Rated VT secondary voltage
VTprim5	0.001 - 9999.999	kV	0.001	132.000	Rated VT primary voltage
VTsec6	0.001 - 999.999	V	0.001	110	Rated VT secondary voltage
VTprim6	0.001 - 9999.999	kV	0.001	132	Rated VT primary voltage
VTsec7	0.001 - 999.999	V	0.001	110.000	Rated VT secondary voltage
VTprim7	0.001 - 9999.999	kV	0.001	132.000	Rated VT primary voltage
VTsec8	0.001 - 999.999	V	0.001	110	Rated VT secondary voltage
VTprim8	0.001 - 9999.999	kV	0.001	132	Rated VT primary voltage
VTsec9	0.001 - 999.999	V	0.001	110.000	Rated VT secondary voltage
VTprim9	0.001 - 9999.999	kV	0.001	132.000	Rated VT primary voltage
VTsec10	0.001 - 999.999	V	0.001	110	Rated VT secondary voltage
VTprim10	0.001 - 9999.999	kV	0.001	132	Rated VT primary voltage

Table 6: AIM_6I_4U Non group settings (basic)

Name	Values (Range)	Unit	Step	Default	Description
CTStarPoint1	FromObject ToObject	-	-	ToObject	ToObject= towards protected object, FromObject= the opposite
CTsec1	0.1 - 10.0	A	0.1	1	Rated CT secondary current
CTprim1	1 - 99999	A	1	1000	Rated CT primary current
CTStarPoint2	FromObject ToObject	-	-	ToObject	ToObject= towards protected object, FromObject= the opposite
CTsec2	0.1 - 10.0	A	0.1	1.0	Rated CT secondary current
CTprim2	1 - 99999	A	1	1000	Rated CT primary current
CTStarPoint3	FromObject ToObject	-	-	ToObject	ToObject= towards protected object, FromObject= the opposite
CTsec3	0.1 - 10.0	A	0.1	1	Rated CT secondary current
CTprim3	1 - 99999	A	1	1000	Rated CT primary current
CTStarPoint4	FromObject ToObject	-	-	ToObject	ToObject= towards protected object, FromObject= the opposite
CTsec4	0.1 - 10.0	A	0.1	1.0	Rated CT secondary current
CTprim4	1 - 99999	A	1	1000	Rated CT primary current
CTStarPoint5	FromObject ToObject	-	-	ToObject	ToObject= towards protected object, FromObject= the opposite
CTsec5	0.1 - 10.0	A	0.1	1	Rated CT secondary current
CTprim5	1 - 99999	A	1	1000	Rated CT primary current

Table continues on next page

Name	Values (Range)	Unit	Step	Default	Description
CTStarPoint6	FromObject ToObject	-	-	ToObject	ToObject= towards protected object, FromObject= the opposite
CTsec6	0.1 - 10.0	A	0.1	1.0	Rated CT secondary current
CTprim6	1 - 99999	A	1	1000	Rated CT primary current
VTsec7	0.001 - 999.999	V	0.001	110.000	Rated VT secondary voltage
VTprim7	0.001 - 9999.999	kV	0.001	132.000	Rated VT primary voltage
VTsec8	0.001 - 999.999	V	0.001	110	Rated VT secondary voltage
VTprim8	0.001 - 9999.999	kV	0.001	132	Rated VT primary voltage
VTsec9	0.001 - 999.999	V	0.001	110.000	Rated VT secondary voltage
VTprim9	0.001 - 9999.999	kV	0.001	132.000	Rated VT primary voltage
VTsec10	0.001 - 999.999	V	0.001	110	Rated VT secondary voltage
VTprim10	0.001 - 9999.999	kV	0.001	132	Rated VT primary voltage

Table 7: AIM_4I_1_5U Non group settings (basic)

Name	Values (Range)	Unit	Step	Default	Description
CTStarPoint1	FromObject ToObject	-	-	ToObject	ToObject= towards protected object, FromObject= the opposite
CTsec1	0.1 - 10.0	A	0.1	1.0	Rated CT secondary current
CTprim1	1 - 99999	A	1	1000	Rated CT primary current
CTStarPoint2	FromObject ToObject	-	-	ToObject	ToObject= towards protected object, FromObject= the opposite
CTsec2	0.1 - 10.0	A	0.1	1.0	Rated CT secondary current
CTprim2	1 - 99999	A	1	1000	Rated CT primary current
CTStarPoint3	FromObject ToObject	-	-	ToObject	ToObject= towards protected object, FromObject= the opposite
CTsec3	0.1 - 10.0	A	0.1	1.0	Rated CT secondary current
CTprim3	1 - 99999	A	1	1000	Rated CT primary current
CTStarPoint4	FromObject ToObject	-	-	ToObject	ToObject= towards protected object, FromObject= the opposite
CTsec4	0.1 - 10.0	A	0.1	1.0	Rated CT secondary current
CTprim4	1 - 99999	A	1	1000	Rated CT primary current
CTStarPoint5	FromObject ToObject	-	-	ToObject	ToObject= towards protected object, FromObject= the opposite
CTsec5	0.1 - 10.0	A	0.1	1.0	Rated CT secondary current
CTprim5	1 - 99999	A	1	1000	Rated CT primary current
VTsec6	0.001 - 999.999	V	0.001	110	Rated VT secondary voltage
VTprim6	0.001 - 9999.999	kV	0.001	132	Rated VT primary voltage
VTsec7	0.001 - 999.999	V	0.001	110.000	Rated VT secondary voltage
VTprim7	0.001 - 9999.999	kV	0.001	132.000	Rated VT primary voltage
VTsec8	0.001 - 999.999	V	0.001	110	Rated VT secondary voltage
VTprim8	0.001 - 9999.999	kV	0.001	132	Rated VT primary voltage
VTsec9	0.001 - 999.999	V	0.001	110.000	Rated VT secondary voltage

Table continues on next page

Name	Values (Range)	Unit	Step	Default	Description
VTprim9	0.001 - 9999.999	kV	0.001	132.000	Rated VT primary voltage
VTsec10	0.001 - 999.999	V	0.001	110.000	Rated VT secondary voltage
VTprim10	0.001 - 9999.999	kV	0.001	132.000	Rated VT primary voltage

Section 4 Binary input and output modules

4.1 Binary input

4.1.1 Binary input debounce filter

The debounce filter eliminates bounces and short disturbances on a binary input.

A time counter is used for filtering. The time counter is increased once in a millisecond when a binary input is high, or decreased when a binary input is low. A new debounced binary input signal is forwarded when the time counter reaches the set *DebounceTime* value and the debounced input value is high or when the time counter reaches 0 and the debounced input value is low. The default setting of *DebounceTime* is 5 ms.

The binary input ON-event gets the time stamp of the first rising edge, after which the counter does not reach 0 again. The same happens when the signal goes down to 0 again.

Each binary input has a filter time parameter *DebounceTime_x*, where x is the number of the binary input of the module in question (for example *DebounceTime1*).



The debounce time should be set to the same value for all channels on the board.

4.1.2 Oscillation filter

Binary input wiring can be very long in substations and there are electromagnetic fields from for example nearby breakers. Floating input lines can result in disturbances to binary inputs. These disturbances are unwanted in the system. An oscillation filter is used to reduce the disturbance from the system when a binary input starts oscillating.

Each debounced input signal change increments of an oscillation counter. Every time the oscillation time counter reaches the set *OscillationTime*, the oscillation counter is checked and both the time counter and the oscillation counter are reset. If the counter value is above the set *OscillationCount* value the signal is declared as oscillating and not valid. If the value is below the set *OscillationCount* value, the signal is declared as valid again. During counting of the oscillation time the status of the signal remains unchanged, leading to a fixed delay in the status update, even if the signal has attained normal status again.

Each binary input has an oscillation count parameter *OscillationCount_x* and an oscillation time parameter *OscillationTime_x*, where x is the number of the binary input of the module in question.

4.1.3 Settings

4.1.3.1 Setting parameters for binary input modules

Table 8: *BIO_9BI Non group settings (basic)*

Name	Values (Range)	Unit	Step	Default	Description
BatteryVoltage	24 - 250	V	1	110	Station battery voltage

Table 9: BIO_9BI Non group settings (advanced)

Name	Values (Range)	Unit	Step	Default	Description
Threshold1	6 - 900	%UB	1	65	Threshold in percentage of station battery voltage for input 1
DebounceTime1	0.000 - 0.100	s	0.001	0.005	Debounce time for input 1
OscillationCount1	0 - 255	-	1	0	Oscillation count for input 1
OscillationTime1	0.000 - 600.000	s	0.001	0.000	Oscillation time for input 1
Threshold2	6 - 900	%UB	1	65	Threshold in percentage of station battery voltage for input 2
DebounceTime2	0.000 - 0.100	s	0.001	0.005	Debounce time for input 2
OscillationCount2	0 - 255	-	1	0	Oscillation count for input 2
OscillationTime2	0.000 - 600.000	s	0.001	0.000	Oscillation time for input 2
Threshold3	6 - 900	%UB	1	65	Threshold in percentage of station battery voltage for input 3
DebounceTime3	0.000 - 0.100	s	0.001	0.005	Debounce time for input 3
OscillationCount3	0 - 255	-	1	0	Oscillation count for input 3
OscillationTime3	0.000 - 600.000	s	0.001	0.000	Oscillation time for input 3
Threshold4	6 - 900	%UB	1	65	Threshold in percentage of station battery voltage for input 4
DebounceTime4	0.000 - 0.100	s	0.001	0.005	Debounce time for input 4
OscillationCount4	0 - 255	-	1	0	Oscillation count for input 4
OscillationTime4	0.000 - 600.000	s	0.001	0.000	Oscillation time for input 4
Threshold5	6 - 900	%UB	1	65	Threshold in percentage of station battery voltage for input 5
DebounceTime5	0.000 - 0.100	s	0.001	0.005	Debounce time for input 5
OscillationCount5	0 - 255	-	1	0	Oscillation count for input 5
OscillationTime5	0.000 - 600.000	s	0.001	0.000	Oscillation time for input 5
Threshold6	6 - 900	%UB	1	65	Threshold in percentage of station battery voltage for input 6
DebounceTime6	0.000 - 0.100	s	0.001	0.005	Debounce time for input 6
OscillationCount6	0 - 255	-	1	0	Oscillation count for input 6
OscillationTime6	0.000 - 600.000	s	0.001	0.000	Oscillation time for input 6
Threshold7	6 - 900	%UB	1	65	Threshold in percentage of station battery voltage for input 7
DebounceTime7	0.000 - 0.100	s	0.001	0.005	Debounce time for input 7
OscillationCount7	0 - 255	-	1	0	Oscillation count for input 7
OscillationTime7	0.000 - 600.000	s	0.001	0.000	Oscillation time for input 7
Threshold8	6 - 900	%UB	1	65	Threshold in percentage of station battery voltage for input 8
DebounceTime8	0.000 - 0.100	s	0.001	0.005	Debounce time for input 8
OscillationCount8	0 - 255	-	1	0	Oscillation count for input 8
OscillationTime8	0.000 - 600.000	s	0.001	0.000	Oscillation time for input 8
Threshold9	6 - 900	%UB	1	65	Threshold in percentage of station battery voltage for input 9
DebounceTime9	0.000 - 0.100	s	0.001	0.005	Debounce time for input 9
OscillationCount9	0 - 255	-	1	0	Oscillation count for input 9
OscillationTime9	0.000 - 600.000	s	0.001	0.000	Oscillation time for input 9

4.1.3.2 Setting parameters for communication module

Table 10: COM05_12BI Non group settings (basic)

Name	Values (Range)	Unit	Step	Default	Description
BatteryVoltage	24 - 250	V	1	110	Station battery voltage

Table 11: COM05_12BI Non group settings (advanced)

Name	Values (Range)	Unit	Step	Default	Description
Threshold1	6 - 900	%UB	1	65	Threshold in percentage of station battery voltage for input 1
DebounceTime1	0.000 - 0.100	s	0.001	0.005	Debounce time for input 1
OscillationCount1	0 - 255	-	1	0	Oscillation count for input 1
OscillationTime1	0.000 - 600.000	s	0.001	0.000	Oscillation time for input 1
Threshold2	6 - 900	%UB	1	65	Threshold in percentage of station battery voltage for input 2
DebounceTime2	0.000 - 0.100	s	0.001	0.005	Debounce time for input 2
OscillationCount2	0 - 255	-	1	0	Oscillation count for input 2
OscillationTime2	0.000 - 600.000	s	0.001	0.000	Oscillation time for input 2
Threshold3	6 - 900	%UB	1	65	Threshold in percentage of station battery voltage for input 3
DebounceTime3	0.000 - 0.100	s	0.001	0.005	Debounce time for input 3
OscillationCount3	0 - 255	-	1	0	Oscillation count for input 3
OscillationTime3	0.000 - 600.000	s	0.001	0.000	Oscillation time for input 3
Threshold4	6 - 900	%UB	1	65	Threshold in percentage of station battery voltage for input 4
DebounceTime4	0.000 - 0.100	s	0.001	0.005	Debounce time for input 4
OscillationCount4	0 - 255	-	1	0	Oscillation count for input 4
OscillationTime4	0.000 - 600.000	s	0.001	0.000	Oscillation time for input 4
Threshold5	6 - 900	%UB	1	65	Threshold in percentage of station battery voltage for input 5
DebounceTime5	0.000 - 0.100	s	0.001	0.005	Debounce time for input 5
OscillationCount5	0 - 255	-	1	0	Oscillation count for input 5
OscillationTime5	0.000 - 600.000	s	0.001	0.000	Oscillation time for input 5
Threshold6	6 - 900	%UB	1	65	Threshold in percentage of station battery voltage for input 6
DebounceTime6	0.000 - 0.100	s	0.001	0.005	Debounce time for input 6
OscillationCount6	0 - 255	-	1	0	Oscillation count for input 6
OscillationTime6	0.000 - 600.000	s	0.001	0.000	Oscillation time for input 6
Threshold7	6 - 900	%UB	1	65	Threshold in percentage of station battery voltage for input 7
DebounceTime7	0.000 - 0.100	s	0.001	0.005	Debounce time for input 7
OscillationCount7	0 - 255	-	1	0	Oscillation count for input 7
OscillationTime7	0.000 - 600.000	s	0.001	0.000	Oscillation time for input 7
Threshold8	6 - 900	%UB	1	65	Threshold in percentage of station battery voltage for input 8

Table continues on next page

Name	Values (Range)	Unit	Step	Default	Description
DebounceTime8	0.000 - 0.100	s	0.001	0.005	Debounce time for input 8
OscillationCount8	0 - 255	-	1	0	Oscillation count for input 8
OscillationTime8	0.000 - 600.000	s	0.001	0.000	Oscillation time for input 8
Threshold9	6 - 900	%UB	1	65	Threshold in percentage of station battery voltage for input 9
DebounceTime9	0.000 - 0.100	s	0.001	0.005	Debounce time for input 9
OscillationCount9	0 - 255	-	1	0	Oscillation count for input 9
OscillationTime9	0.000 - 600.000	s	0.001	0.000	Oscillation time for input 9
Threshold10	6 - 900	%UB	1	65	Threshold in percentage of station battery voltage for input 10
DebounceTime10	0.000 - 0.100	s	0.001	0.005	Debounce time for input 10
OscillationCount10	0 - 255	-	1	0	Oscillation count for input 10
OscillationTime10	0.000 - 600.000	s	0.001	0.000	Oscillation time for input 10
Threshold11	6 - 900	%UB	1	65	Threshold in percentage of station battery voltage for input 11
DebounceTime11	0.000 - 0.100	s	0.001	0.005	Debounce time for input 11
OscillationCount11	0 - 255	-	1	0	Oscillation count for input 11
OscillationTime11	0.000 - 600.000	s	0.001	0.000	Oscillation time for input 11
Threshold12	6 - 900	%UB	1	65	Threshold in percentage of station battery voltage for input 12
DebounceTime12	0.000 - 0.100	s	0.001	0.005	Debounce time for input 12
OscillationCount12	0 - 255	-	1	0	Oscillation count for input 12
OscillationTime12	0.000 - 600.000	s	0.001	0.000	Oscillation time for input 12

Section 5 Local Human-Machine-Interface LHMI

5.1 Local HMI screen behaviour

5.1.1 Identification

Function description	IEC 61850 identification	IEC 60617 identification	ANSI/IEEE C37.2 device number
Local HMI screen behaviour	SCREEN	-	-

5.1.2 Settings

Table 12: SCREEN Non group settings (basic)

Name	Values (Range)	Unit	Step	Default	Description
DisplayTimeout	10 - 120	Min	10	60	Local HMI display timeout
ContrastLevel	-100 - 100	%	10	0	Contrast level for display
DefaultScreen	0 - 0	-	1	0	Default screen
EvListSrtOrder	Latest on top Oldest on top	-	-	Latest on top	Sort order of event list
AutoIndicationDRP	Off On	-	-	Off	Automatic indication of disturbance report
SubstIndSLD	No Yes	-	-	No	Substitute indication on single line diagram
InterlockIndSLD	No Yes	-	-	No	Interlock indication on single line diagram
BypassCommands	No Yes	-	-	No	Enable bypass of commands

5.2 Local HMI signals

5.2.1 Identification

Function description	IEC 61850 identification	IEC 60617 identification	ANSI/IEEE C37.2 device number
Local HMI signals	LHMICTRL	-	-

5.2.2 Function block

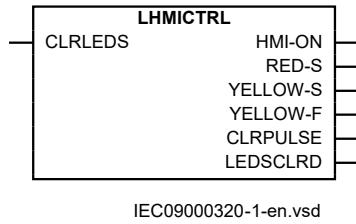

IEC09000320-1-en.vsd

Figure 3: LHMICTRL function block

5.2.3 Signals

Table 13: LHMICTRL Input signals

Name	Type	Default	Description
CLRLEDS	BOOLEAN	0	Input to clear the LCD-HMI LEDs

Table 14: LHMICTRL Output signals

Name	Type	Description
HMI-ON	BOOLEAN	Backlight of the LCD display is active
RED-S	BOOLEAN	Red LED on the LCD-HMI is steady
YELLOW-S	BOOLEAN	Yellow LED on the LCD-HMI is steady
YELLOW-F	BOOLEAN	Yellow LED on the LCD-HMI is flashing
CLRPULSE	BOOLEAN	A pulse is provided when the LEDs on the LCD-HMI are cleared
LEDSCLRD	BOOLEAN	Active when the LEDs on the LCD-HMI are not active

5.3 Basic part for LED indication module

5.3.1 Identification

Function description	IEC 61850 identification	IEC 60617 identification	ANSI/IEEE C37.2 device number
Basic part for LED indication module	LEDGEN	-	-
Basic part for LED indication module	GRP1_LED1 - GRP1_LED15 GRP2_LED1 - GRP2_LED15 GRP3_LED1 - GRP3_LED15	-	-

5.3.2 Function block

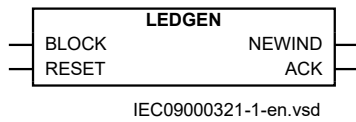

Figure 4: LEDGEN function block

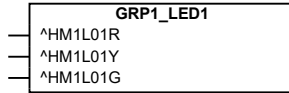

Figure 5: GRP1_LED1 function block

The GRP1_LED1 function block is an example, all 15 LED in each of group 1 - 3 has a similar function block.

5.3.3 Signals

Table 15: LEDGEN Input signals

Name	Type	Default	Description
BLOCK	BOOLEAN	0	Input to block the operation of the LEDs
RESET	BOOLEAN	0	Input to acknowledge/reset the indication LEDs

Table 16: GRP1_LED1 Input signals

Name	Type	Default	Description
HM1L01R	BOOLEAN	0	Red indication of LED1, local HMI alarm group 1
HM1L01Y	BOOLEAN	0	Yellow indication of LED1, local HMI alarm group 1
HM1L01G	BOOLEAN	0	Green indication of LED1, local HMI alarm group 1

Table 17: LEDGEN Output signals

Name	Type	Description
NEWIND	BOOLEAN	New indication signal if any LED indication input is set
ACK	BOOLEAN	A pulse is provided when the LEDs are acknowledged

5.3.4 Settings

Table 18: LEDGEN Non group settings (basic)

Name	Values (Range)	Unit	Step	Default	Description
Operation	Off On	-	-	Off	Operation Off/On
tRestart	0.0 - 100.0	s	0.1	0.0	Defines the disturbance length
tMax	0.0 - 100.0	s	0.1	0.0	Maximum time for the definition of a disturbance

Table 19: GRP1_LED1 Non group settings (basic)

Name	Values (Range)	Unit	Step	Default	Description
SequenceType	Follow-S Follow-F LatchedAck-F-S LatchedAck-S-F LatchedColl-S LatchedReset-S	-	-	Follow-S	Sequence type for LED 1, local HMI alarm group 1
LabelOff	0 - 18	-	1	G1L01_OFF	Label string shown when LED 1, alarm group 1 is off
LabelRed	0 - 18	-	1	G1L01_RED	Label string shown when LED 1, alarm group 1 is red
LabelYellow	0 - 18	-	1	G1L01_YELLOW	Label string shown when LED 1, alarm group 1 is yellow
LabelGreen	0 - 18	-	1	G1L01_GREEN	Label string shown when LED 1, alarm group 1 is green

5.4 LCD part for HMI function keys control module

5.4.1 Identification

Function description	IEC 61850 identification	IEC 60617 identification	ANSI/IEEE C37.2 device number
LCD part for HMI Function Keys Control module	FNKEYMD1 - FNKEYMD5	-	-

5.4.2 Function block



Figure 6: FNKEYMD1 function block

Only the function block for the first button is shown above. There is a similar block for every function button.

5.4.3 Signals

Table 20: FNKEYMD1 Input signals

Name	Type	Default	Description
LEDCTL1	BOOLEAN	0	LED control input for function key

Table 21: FNKEYMD1 Output signals

Name	Type	Description
FKEYOUT1	BOOLEAN	Output controlled by function key

5.4.4 Settings

Table 22: FNKEYMD1 Non group settings (basic)

Name	Values (Range)	Unit	Step	Default	Description
Mode	Off Toggle Pulsed	-	-	Off	Output operation mode
PulseTime	0.001 - 60.000	s	0.001	0.200	Pulse time for output controlled by LCDFn1
LabelOn	0 - 18	-	1	LCD_FN1_ON	Label for LED on state
LabelOff	0 - 18	-	1	LCD_FN1_OFF	Label for LED off state

Table 23: FNKEYTY1 Non group settings (basic)

Name	Values (Range)	Unit	Step	Default	Description
Type	Off Menu shortcut Control	-	-	Off	Function key type
MenuShortcut	Menu shortcut for function key				

5.5 Operation principle

5.5.1 Local HMI



Figure 7: Local human-machine interface

The LHMI of the IED contains the following elements:

- Display (LCD)
- Buttons
- LED indicators
- Communication port for PCM600

The LHMI is used for setting, monitoring and controlling.

5.5.1.1 Display

The LHMI includes a graphical monochrome display with a resolution of 320 x 240 pixels. The character size can vary. The amount of characters and rows fitting the view depends on the character size and the view that is shown.

The display view is divided into four basic areas.

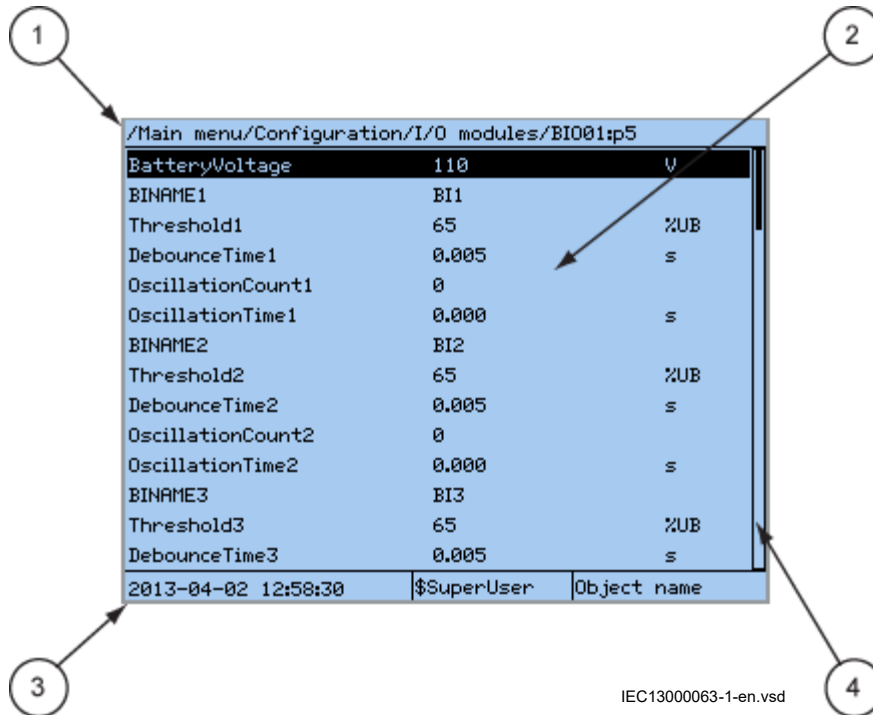

Figure 8: Display layout

- 1 Path
- 2 Content
- 3 Status
- 4 Scroll bar (appears when needed)

- The path shows the current location in the menu structure. If the path is too long to be shown, it is truncated from the beginning, and the truncation is indicated with three dots.
- The content area shows the menu content.
- The status area shows the current IED time, the user that is currently logged in and the object identification string which is settable via the LHMI or with PCM600.
- If text, pictures or other items do not fit in the display, a vertical scroll bar appears on the right. The text in content area is truncated from the beginning if it does not fit in the display horizontally. Truncation is indicated with three dots.

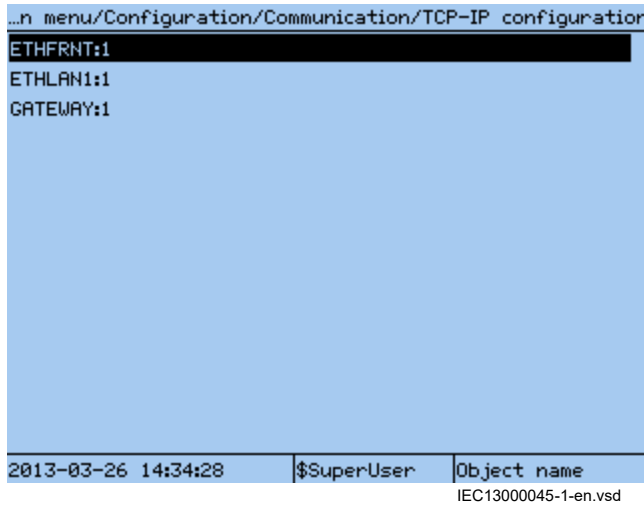

Figure 9: Truncated path

The number before the function instance, for example `ETHFRNT:1`, indicates the instance number.

The function button panel shows on request what actions are possible with the function buttons. Each function button has a LED indication that can be used as a feedback signal for the function button control action. The LED is connected to the required signal with PCM600.

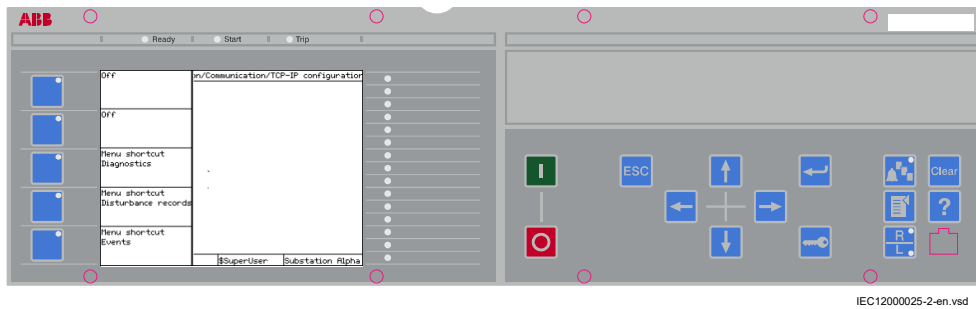

Figure 10: Function button panel

The alarm LED panel shows on request the alarm text labels for the alarm LEDs. Three alarm LED pages are available.

/Main menu	1	G2L01_YELLOW
Control	2	
Events	3	
Measurements		
Disturbance records		G2L05_YELLOW
Settings		
Configuration		TRIP CKT ALARM
Diagnostics		
Tests		
Clear		
Languages		
2009-06-24 10:41:24	\$SuperUser	

Figure 11: Alarm LED panel

The function button and alarm LED panels are not visible at the same time. Each panel is shown by pressing one of the function buttons or the Multipage button. Pressing the ESC button clears the panel from the display. Both the panels have dynamic width that depends on the label string length that the panel contains.

5.5.1.2 LEDs

The LHMI includes three protection status LEDs above the display: Ready, Start and Trip.

There are 15 programmable alarm LEDs on the front of the LHMI. Each LED can indicate three states with the colors: green, yellow and red. The alarm texts related to each three-color LED are divided into three pages.

There are 3 separate pages of LEDs available. The 15 physical three-color LEDs in one LED group can indicate 45 different signals. Altogether, 135 signals can be indicated since there are three LED groups. The LEDs can be configured with PCM600 and the operation mode can be selected with the LHMI or PCM600.

5.5.1.3 Keypad

The LHMI keypad contains push-buttons which are used to navigate in different views or menus. With the push-buttons you can give open or close commands to one primary object, for example, a circuit breaker, disconnecter or an earthing switch. The push-buttons are also used to acknowledge alarms, reset indications, provide help and switch between local and remote control mode.

The keypad also contains programmable push-buttons that can be configured either as menu shortcut or control buttons.

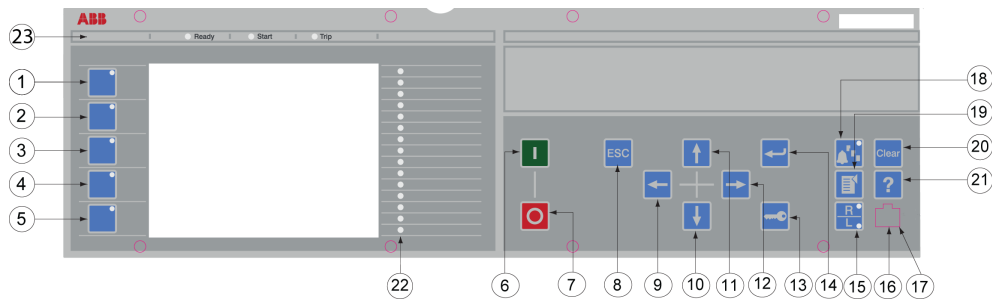

Figure 12: LHMI keypad with object control, navigation and command push-buttons and RJ-45 communication port

- 1...5 Function button
- 6 Close
- 7 Open
- 8 Escape
- 9 Left
- 10 Down
- 11 Up
- 12 Right
- 13 User Log on
- 14 Enter
- 15 Remote/Local
- 16 Uplink LED
- 17 Ethernet communication port (RJ-45)
- 18 Multipage
- 19 Menu
- 20 Clear
- 21 Help
- 22 Programmable alarm LEDs
- 23 Protection status LEDs

5.5.2 LED

5.5.2.1 Functionality

The function blocks LEDGEN and GRP1_LEDx, GRP2_LEDx and GRP3_LEDx (x=1-15) controls and supplies information about the status of the indication LEDs. The input and output signals of the function blocks are configured with PCM600. The input signal for each LED is selected individually using SMT or ACT. Each LED is controlled by a GRP1_LEDx function block, that controls the color and the operating mode.

Each indication LED on local HMI can be set individually to operate in 6 different sequences; two as follow type and four as latch type. Two of the latching sequence types are intended to be used as a protection indication system, either in collecting or restarting mode, with reset functionality. The other two are intended to be used as signalling system in collecting mode with acknowledgment functionality.

5.5.2.2 Status LEDs

There are three status LEDs above the LCD in the front of the IED, green, yellow and red.

The green LED has a fixed function that present the healthy status of the IED. The yellow and red LEDs are user configured. The yellow LED can be used to indicate that a disturbance report is triggered (steady) or that the IED is in test mode (flashing). The red LED can be used to indicate a trip command.

The yellow and red status LEDs are configured in the disturbance recorder function, DRPRDRE, by connecting a start or trip signal from the actual function to a BxRBDR binary input function block using the PCM600 and configure the setting to *Off*, *Start* or *Trip* for that particular signal.

5.5.2.3 Indication LEDs

Operating modes

Collecting mode

- LEDs, which are used in collecting mode of operation, are accumulated continuously until the unit is acknowledged manually. This mode is suitable when the LEDs are used as a simplified alarm system.

Re-starting mode

- In the re-starting mode of operation each new start resets all previous active LEDs and activates only those, which appear during one disturbance. Only LEDs defined for re-starting mode with the latched sequence type 6 (LatchedReset-S) will initiate a reset and a restart at a new disturbance. A disturbance is defined to end a settable time after the reset of the activated input signals or when the maximum time limit has elapsed.

Acknowledgment/reset

- From local HMI
 - The active indications can be acknowledged/reset manually. Manual acknowledgment and manual reset have the same meaning and is a common signal for all the operating sequences and LEDs. The function is positive edge triggered, not level triggered. The acknowledgment/reset is performed via the  button and menus on the LHMI.
- From function input
 - The active indications can also be acknowledged/reset from an input, ACK_RST, to the function. This input can for example be configured to a binary input operated from an external push button. The function is positive edge triggered, not level triggered. This means that even if the button is continuously pressed, the acknowledgment/reset only affects indications active at the moment when the button is first pressed.
- Automatic reset
 - The automatic reset can only be performed for indications defined for re-starting mode with the latched sequence type 6 (LatchedReset-S). When the automatic reset of the LEDs has been performed, still persisting indications will be indicated with a steady light.

Operating sequence

The sequences can be of type Follow or Latched. For the Follow type the LED follow the input signal completely. For the Latched type each LED latches to the corresponding input signal until it is reset.

The figures below show the function of available sequences selectable for each LED separately. For *sequence 1* and *2* Follow type, the acknowledgment/reset function is not applicable. *Sequence 3* and *4* Latched type with acknowledgement are only working in collecting mode. *Sequence 5* is working according to Latched type and collecting mode while *Sequence 6* is working according to Latched type and re-starting mode. The letters *S* and *F* in the sequence names have the meaning *S* = Steady and *F* = Flash.

At the activation of the input signal, the indication obtains corresponding color corresponding to the activated input and operates according to the selected sequence diagrams below.

In the sequence diagrams the LEDs have the following characteristics:

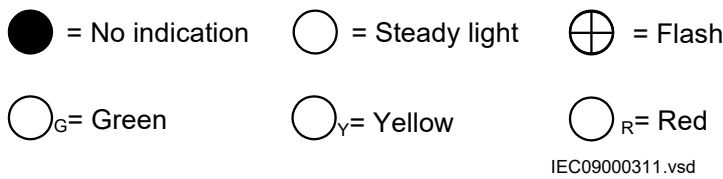

Figure 13: Symbols used in the sequence diagrams

Sequence 1 (Follow-S)

This sequence follows all the time, with a steady light, the corresponding input signals. It does not react on acknowledgment or reset. Every LED is independent of the other LEDs in its operation.

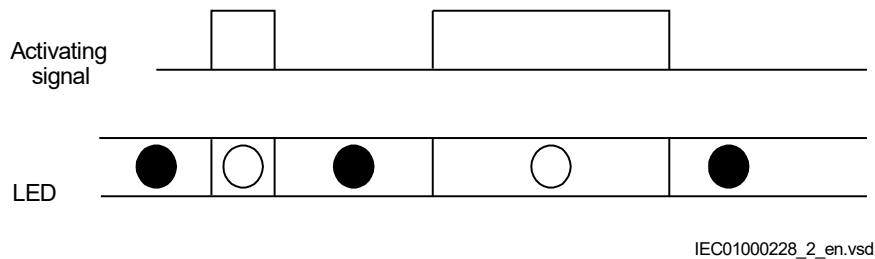

Figure 14: Operating Sequence 1 (Follow-S)

If inputs for two or more colors are active at the same time to one LED the priority is as described above. An example of the operation when two colors are activated in parallel is shown in [Figure 15](#).

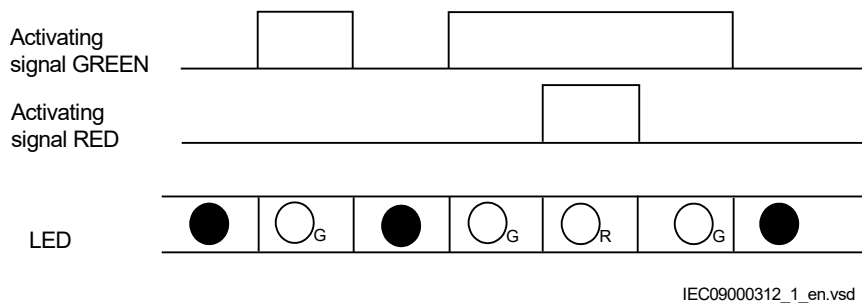

Figure 15: Operating sequence 1, two colors

Sequence 2 (Follow-F)

This sequence is the same as *Sequence 1, Follow-S*, but the LEDs are flashing instead of showing steady light.

Sequence 3 LatchedAck-F-S

This sequence has a latched function and works in collecting mode. Every LED is independent of the other LEDs in its operation. At the activation of the input signal, the indication starts flashing. After acknowledgment the indication disappears if the signal is not present any more. If the signal is still present after acknowledgment it gets a steady light.

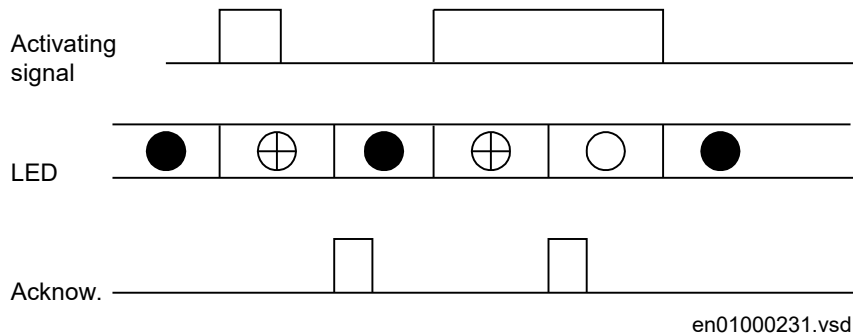

Figure 16: Operating Sequence 3 LatchedAck-F-S

When an acknowledgment is performed, all indications that appear before the indication with higher priority has been reset, will be acknowledged, independent of if the low priority indication appeared before or after acknowledgment. In [Figure 17](#) it is shown the sequence when a signal of lower priority becomes activated after acknowledgment has been performed on a higher priority signal. The low priority signal will be shown as acknowledged when the high priority signal resets.

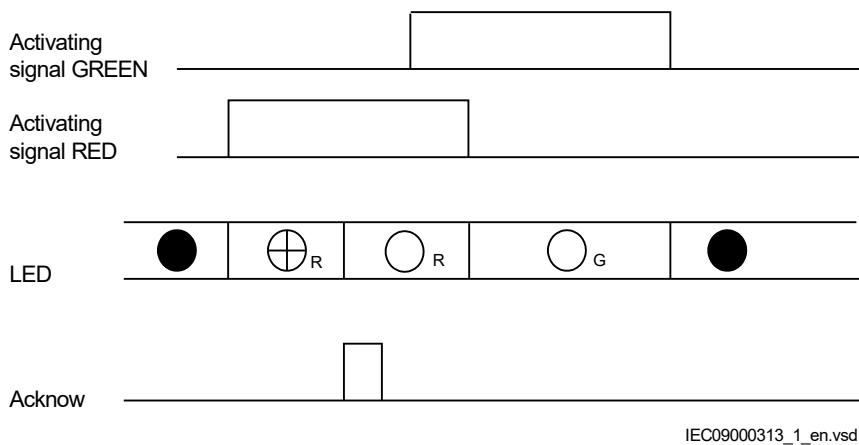

Figure 17: Operating Sequence 3 (LatchedAck-F-S), 2 colors involved

If all three signals are activated the order of priority is still maintained. Acknowledgment of indications with higher priority will acknowledge also low priority indications, which are not visible according to [Figure 18](#).

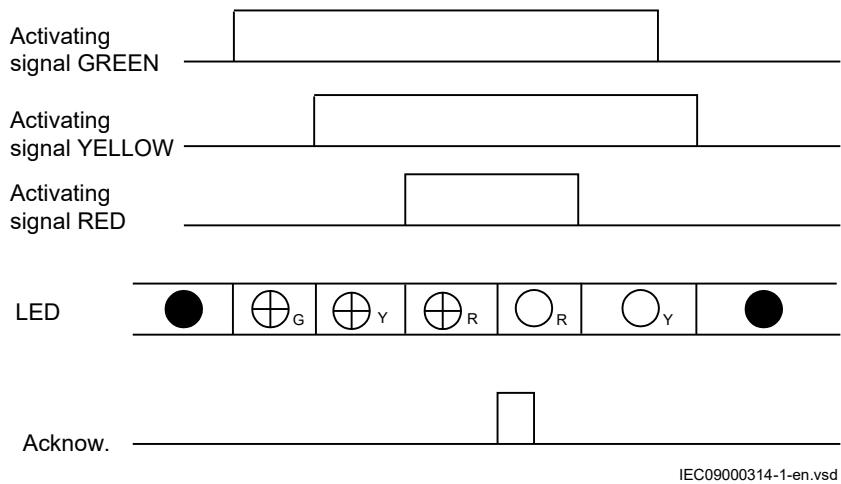

Figure 18: Operating sequence 3, three colors involved, alternative 1

If an indication with higher priority appears after acknowledgment of a lower priority indication the high priority indication will be shown as not acknowledged according to [Figure 19](#).

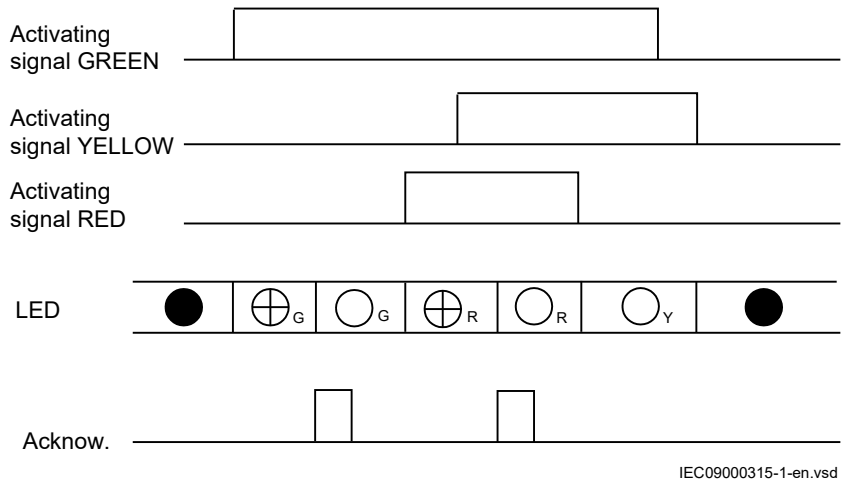

Figure 19: Operating sequence 3, three colors involved, alternative 2

Sequence 4 (LatchedAck-S-F)

This sequence has the same functionality as sequence 3, but steady and flashing light have been alternated.

Sequence 5 LatchedColl-S

This sequence has a latched function and works in collecting mode. At the activation of the input signal, the indication will light up with a steady light. The difference to sequence 3 and 4 is that indications that are still activated will not be affected by the reset that is, immediately after the positive edge of the reset has been executed a new reading and storing of active signals is performed. Every LED is independent of the other LEDs in its operation.

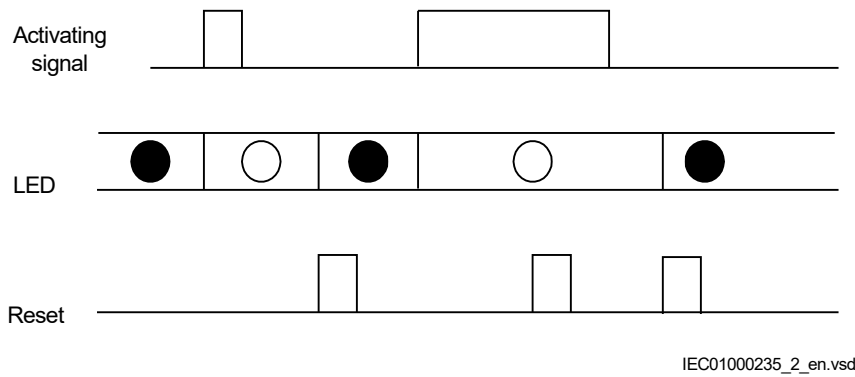

Figure 20: Operating Sequence 5 LatchedColl-S

That means if an indication with higher priority has reset while an indication with lower priority still is active at the time of reset, the LED will change color according to [Figure 21](#).

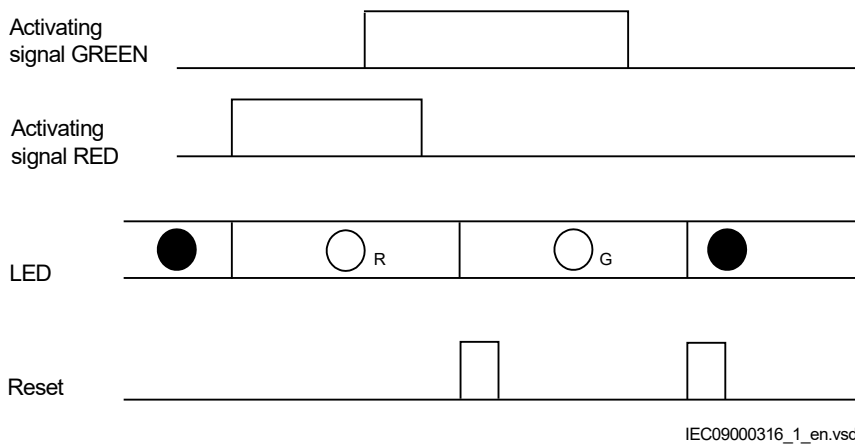

Figure 21: Operating sequence 5, two colors

Sequence 6 LatchedReset-S

In this mode all activated LEDs, which are set to *Sequence 6* (LatchedReset-S), are automatically reset at a new disturbance when activating any input signal for other LEDs set to *Sequence 6* LatchedReset-S. Also in this case indications that are still activated will not be affected by manual reset, that is, immediately after the positive edge of that the manual reset has been executed a new reading and storing of active signals is performed. LEDs set for sequence 6 are completely independent in its operation of LEDs set for other sequences.

Timing diagram for sequence 6

[Figure 22](#) shows the timing diagram for two indications within one disturbance.

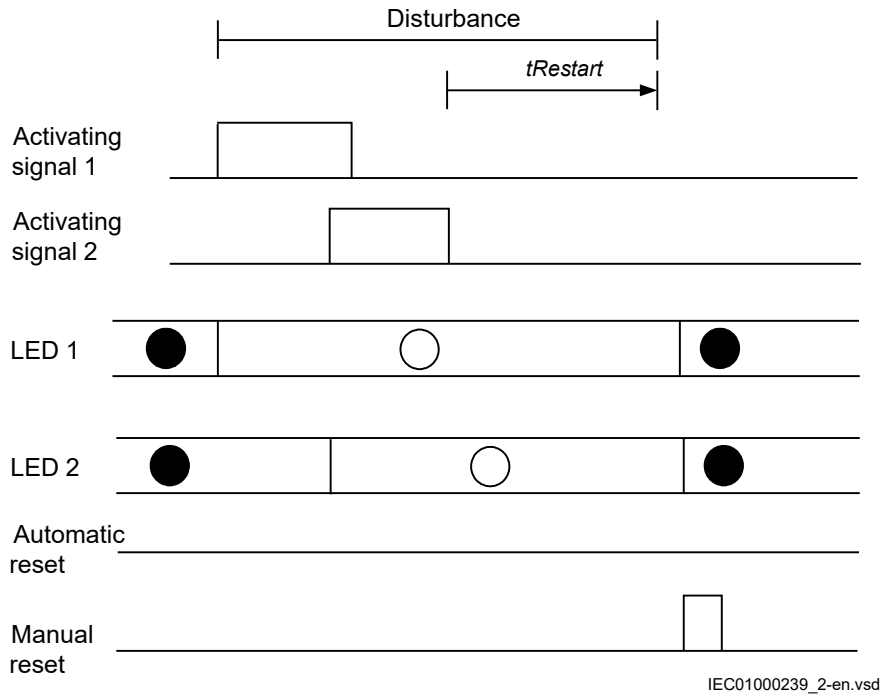

Figure 22: Operating sequence 6 (LatchedReset-S), two indications within same disturbance

Figure 23 shows the timing diagram for a new indication after $t_{Restart}$ time has elapsed.

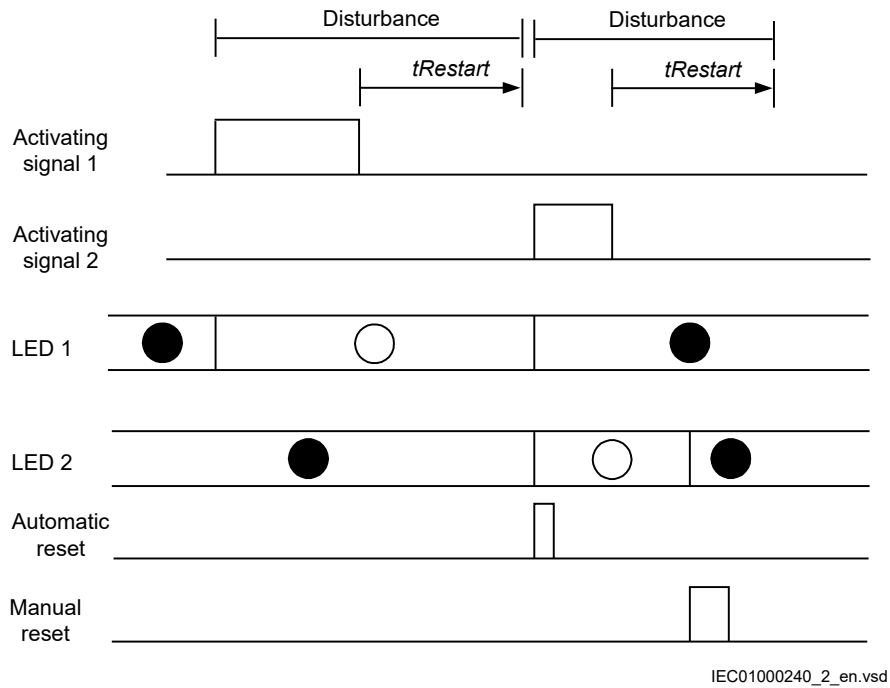

Figure 23: Operating sequence 6 (LatchedReset-S), two different disturbances

Figure 24 shows the timing diagram when a new indication appears after the first one has reset but before $t_{Restart}$ has elapsed.

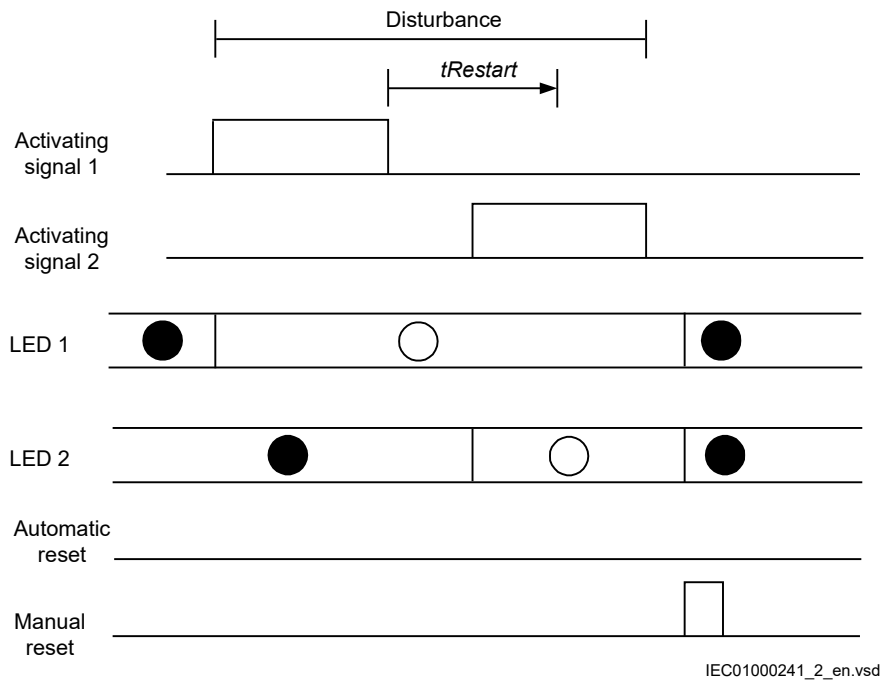

Figure 24: Operating sequence 6 (LatchedReset-S), two indications within same disturbance but with reset of activating signal between

Figure 25 shows the timing diagram for manual reset.

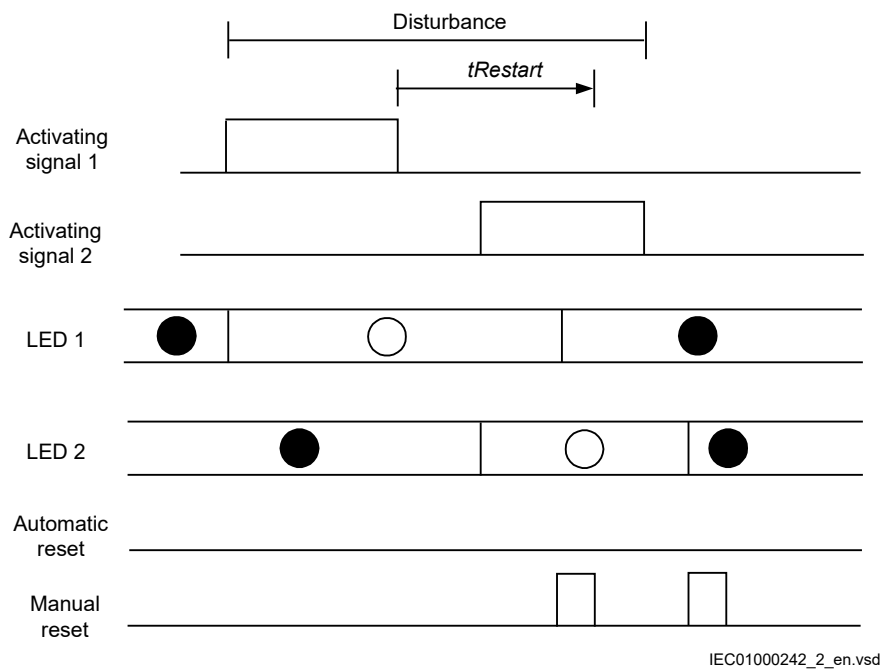

Figure 25: Operating sequence 6 (LatchedReset-S), manual reset

5.5.3 Function keys

5.5.3.1 Functionality

Local Human-Machine-Interface (LHMI) has five function buttons, directly to the left of the LCD, that can be configured either as menu shortcut or control buttons. Each button has an indication LED that can be configured in the application configuration.

When used as a menu shortcut, a function button provides a fast way to navigate between default nodes in the menu tree. When used as a control, the button can control a binary signal.

5.5.3.2 Operation principle

Each output on the FNKEYMD1 - FNKEYMD5 function blocks can be controlled from the LHMI function keys. By pressing a function button on the LHMI, the output status of the actual function block will change. These binary outputs can in turn be used to control other function blocks, for example, switch control blocks, binary I/O outputs etc.

FNKEYMD1 - FNKEYMD5 function block also has a number of settings and parameters that control the behavior of the function block. These settings and parameters are normally set using the PST.

Operating sequence

The operation mode is set individually for each output, either *OFF*, *TOGGLE* or *PULSED*.

Setting *OFF*

This mode always gives the output the value. A change of the input value does not affect the output value.

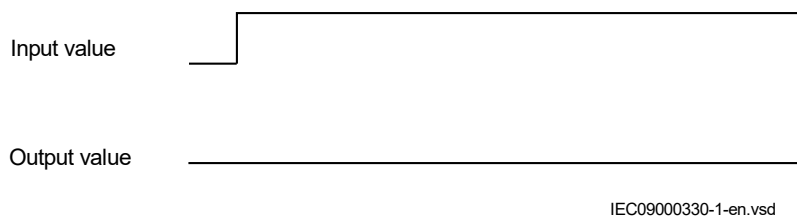

Figure 26: Sequence diagram for setting *OFF*

Setting *TOGGLE*

In this mode the output toggles each time the function block detects that the input has been written (the input has completed a pulse). Note that the input attribute is reset each time the function block executes. The function block execution is marked with a dotted line below.

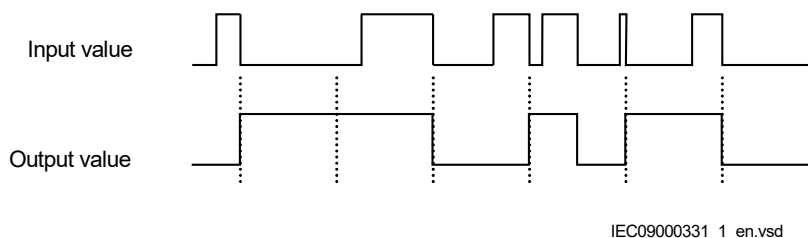

Figure 27: Sequence diagram for setting *TOGGLE*

Setting *PULSED*

In this mode the output will be high for as long as the setting *pulse time*. After this time the output will go back to 0. The input attribute is reset when the function block detects it being high and there is no output pulse.

Note that the third positive edge on the input attribute does not cause a pulse, since the edge was applied during pulse output. A new pulse can only begin when the output is zero; else the trigger edge is lost.

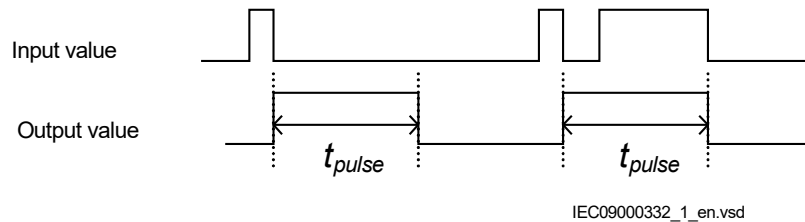

Figure 28: Sequence diagram for setting PULSED

Input function

All inputs work the same way: When the LHMI is configured so that a certain function button is of type CONTROL, then the corresponding input on this function block becomes active, and will light the yellow function button LED when high. This functionality is active even if the function block operation setting is set to off.

There is an exception for the optional extension EXT1 function keys 7 and 8, since they are tri-color (they can be red, yellow or green). Each of these LEDs are controlled by three inputs, which are prioritized in the following order: Red - Yellow - Green

INPUT			OUTPUT
RED	YELLOW	GREEN	Function key LED color
1	0/1	0/1	red
-	1	0/1	yellow
-	-	1	green
0	0	0	off

Section 6 Current protection

6.1 Instantaneous phase overcurrent protection 3-phase output PHPIOC

6.1.1 Identification

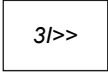
Function description	IEC 61850 identification	IEC 60617 identification	ANSI/IEEE C37.2 device number
Instantaneous phase overcurrent protection 3-phase output	PHPIOC		50

6.1.2 Functionality

The instantaneous three phase overcurrent function has a low transient overreach and short tripping time to allow use as a high set short-circuit protection function.

6.1.3 Function block

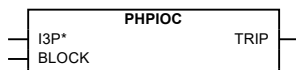

Figure 29: PHPIOC function block

6.1.4 Signals

Table 24: PHPIOC Input signals

Name	Type	Default	Description
I3P	GROUP SIGNAL	-	Three phase group signal for current inputs
BLOCK	BOOLEAN	0	Block of function

Table 25: PHPIOC Output signals

Name	Type	Description
TRIP	BOOLEAN	General trip signal

6.1.5 Settings

Table 26: PHPIOC Group settings (basic)

Name	Values (Range)	Unit	Step	Default	Description
Operation	Off On	-	-	Off	Operation Off / On
IP>>	5 - 2500	%IB	1	200	Operate phase current level in % of IBase

Table 27: PHPIOC Non group settings (basic)

Name	Values (Range)	Unit	Step	Default	Description
GlobalBaseSel	1 - 6	-	1	1	Selection of one of the Global Base Value groups

6.1.6 Monitored data

Table 28: PHPIOC Monitored data

Name	Type	Values (Range)	Unit	Description
IL1	REAL	-	A	Current in phase L1
IL2	REAL	-	A	Current in phase L2
IL3	REAL	-	A	Current in phase L3

6.1.7 Operation principle

The sampled analogue phase currents are pre-processed in a discrete Fourier filter (DFT) block. The RMS value of each phase current is derived from the fundamental frequency components, as well as sampled values of each phase current. These phase current values are fed to the instantaneous phase overcurrent protection 3-phase output function PHPIOC. In a comparator the RMS values are compared to the set operation current value of the function (IP>>). If a phase current is larger than the set operation current a signal from the comparator for this phase is set to true. This signal will, without delay, activate the TRIP signal that is common for all three phases.

PHPIOC can be blocked from the binary input BLOCK.

6.1.8 Technical data

Table 29: PHPIOC technical data

Function	Range or value	Accuracy
Operate current	(5-2500)% of IBase	$\pm 1.0\%$ of I_r at $I \leq I_r$ $\pm 1.0\%$ of I at $I > I_r$
Reset ratio	> 95%	-
Operate time	20 ms typically at 0 to $2 \times I_{set}$	-
Reset time	30 ms typically at 2 to $0 \times I_{set}$	-
Table continues on next page		

Function	Range or value	Accuracy
Critical impulse time	10 ms typically at 0 to $2 \times I_{set}$	-
Operate time	10 ms typically at 0 to $5 \times I_{set}$	-
Reset time	40 ms typically at 5 to $0 \times I_{set}$	-
Critical impulse time	2 ms typically at 0 to $5 \times I_{set}$	-
Dynamic overreach	< 5% at $\tau = 100$ ms	-

6.2 Four step phase overcurrent protection 3-phase output OC4PTOC

6.2.1 Identification

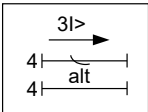
Function description	IEC 61850 identification	IEC 60617 identification	ANSI/IEEE C37.2 device number
Four step phase overcurrent protection 3-phase output	OC4PTOC		51/67

6.2.2 Functionality

The four step phase overcurrent protection function, 3-phase output OC4PTOC has an inverse or definite time delay independent for step 1 and 4 separately. Step 2 and 3 are always definite time delayed.

All IEC and ANSI inverse time characteristics are available.

The directional function is voltage polarized with memory. The function can be set to be directional or non-directional independently for each of the steps.

Second harmonic blocking level can be set for the function and can be used to block each step individually

6.2.3 Function block

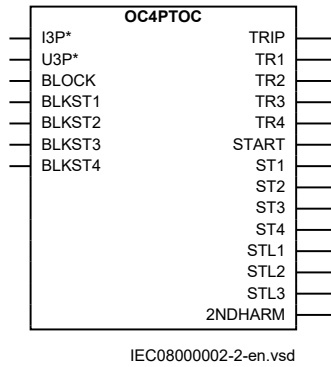

Figure 30: OC4PTOC function block

6.2.4 Signals

Table 30: OC4PTOC Input signals

Name	Type	Default	Description
I3P	GROUP SIGNAL	-	Three phase group signal for current inputs
U3P	GROUP SIGNAL	-	Three phase group signal for voltage inputs
BLOCK	BOOLEAN	0	Block of function
BLKST1	BOOLEAN	0	Block of step 1
BLKST2	BOOLEAN	0	Block of step 2
BLKST3	BOOLEAN	0	Block of step 3
BLKST4	BOOLEAN	0	Block of step 4

Table 31: OC4PTOC Output signals

Name	Type	Description
TRIP	BOOLEAN	General trip signal
TR1	BOOLEAN	Trip signal from step 1
TR2	BOOLEAN	Trip signal from step 2
TR3	BOOLEAN	Trip signal from step 3
TR4	BOOLEAN	Trip signal from step 4
START	BOOLEAN	General start signal
ST1	BOOLEAN	Start signal from step 1
ST2	BOOLEAN	Start signal from step 2
ST3	BOOLEAN	Start signal from step 3
ST4	BOOLEAN	Start signal from step 4
STL1	BOOLEAN	Start signal from phase L1

Table continues on next page

Name	Type	Description
STL2	BOOLEAN	Start signal from phase L2
STL3	BOOLEAN	Start signal from phase L3
ST2NDHRM	BOOLEAN	Second harmonic detected

6.2.5 Settings

Table 32: OC4PTOC Group settings (basic)

Name	Values (Range)	Unit	Step	Default	Description
Operation	Off On	-	-	Off	Operation Off / On
DirMode1	Off Non-directional Forward Reverse	-	-	Non-directional	Directional mode of step 1 off / non-directional / forward / reverse
Characterist1	ANSI Ext. inv. ANSI Very inv. ANSI Norm. inv. ANSI Mod. inv. ANSI Def. Time L.T.E. inv. L.T.V. inv. L.T. inv. IEC Norm. inv. IEC Very inv. IEC inv. IEC Ext. inv. IEC S.T. inv. IEC L.T. inv. IEC Def. Time Reserved RI type RD type	-	-	ANSI Def. Time	Selection of time delay curve type for step 1
I1>	5 - 2500	%IB	1	1000	Phase current operate level for step1 in % of IBase
t1	0.000 - 60.000	s	0.001	0.000	Definite time delay of step 1
k1	0.05 - 999.00	-	0.01	0.05	Time multiplier for the inverse time delay for step 1
IMin1	5 - 10000	%IB	1	100	Minimum operate current for step1 in % of IBase
t1Min	0.000 - 60.000	s	0.001	0.000	Minimum operate time for inverse curves for step 1
DirMode2	Off Non-directional Forward Reverse	-	-	Non-directional	Directional mode of step 2 off / non-directional / forward / reverse
I2>	5 - 2500	%IB	1	500	Phase current operate level for step 2 in % of IBase
t2	0.000 - 60.000	s	0.001	0.400	Definite time delay of step 2
DirMode3	Off Non-directional Forward Reverse	-	-	Non-directional	Directional mode of step 3 off / non-directional / forward / reverse
I3>	5 - 2500	%IB	1	250	Phase current operate level for step3 in % of IBase

Table continues on next page

Name	Values (Range)	Unit	Step	Default	Description
t3	0.000 - 60.000	s	0.001	0.800	Definite time delay of step 3
DirMode4	Off Non-directional Forward Reverse	-	-	Non-directional	Directional mode of step 4 off / non-directional / forward / reverse
Characterist4	ANSI Ext. inv. ANSI Very inv. ANSI Norm. inv. ANSI Def. Time L.T.E. inv. L.T.V. inv. L.T. inv. IEC Norm. inv. IEC Very inv. IEC inv. IEC Ext. inv. IEC S.T. inv. IEC L.T. inv. IEC Def. Time Reserved RI type RD type	-	-	ANSI Def. Time	Selection of time delay curve type for step 4
I4>	5 - 2500	%IB	1	175	Phase current operate level for step 4 in % of IBase
t4	0.000 - 60.000	s	0.001	2.000	Definite time delay of step 4
k4	0.05 - 999.00	-	0.01	0.05	Time multiplier for the inverse time delay for step 4
IMin4	5 - 10000	%IB	1	100	Minimum operate current for step4 in % of IBase
t4Min	0.000 - 60.000	s	0.001	0.000	Minimum operate time for inverse curves for step 4

Table 33: OC4PTOC Group settings (advanced)

Name	Values (Range)	Unit	Step	Default	Description
HarmRestraining	Off On	-	-	Off	Enable block from harmonic restrain
2ndHarmStab	5 - 100	%IFund	1	20	Operate level of 2nd harm restrain op in % of Fundamental
HarmRestraining1	Off On	-	-	Off	Enable block of step 1 from harmonic restrain
HarmRestraining2	Off On	-	-	Off	Enable block of step 2 from harmonic restrain
HarmRestraining3	Off On	-	-	Off	Enable block of step3 from harmonic restrain
HarmRestraining4	Off On	-	-	Off	Enable block of step 4 from harmonic restrain

Table 34: OC4PTOC Non group settings (basic)

Name	Values (Range)	Unit	Step	Default	Description
GlobalBaseSel	1 - 6	-	1	1	Selection of one of the Global Base Value groups
MeasType	DFT RMS	-	-	DFT	Selection between DFT and RMS measurement

6.2.6 Monitored data

Table 35: OC4PTOC Monitored data

Name	Type	Values (Range)	Unit	Description
DIRL1	INTEGER	1=Forward 2=Reverse 0=No direction	-	Direction for phase L1
DIRL2	INTEGER	1=Forward 2=Reverse 0=No direction	-	Direction for phase L2
DIRL3	INTEGER	1=Forward 2=Reverse 0=No direction	-	Direction for phase L3
IL1	REAL	-	A	Current in phase L1
IL2	REAL	-	A	Current in phase L2
IL3	REAL	-	A	Current in phase L3

6.2.7 Operation principle

The Four step phase overcurrent protection 3-phase output OC4PTOC is divided into four different sub-functions, one for each step. For each step x , where x is step 1, 2, 3 and 4, an operation mode is set by *DirModex*: *Off/ Non-directional/ Forward/ Reverse*.

The protection design can be divided in four parts:

- The direction element
- The harmonic Restraint Blocking function
- The four step over current function
- The mode selection



If VT inputs are not available or not connected, setting parameter *DirModex* shall be left to default value, *Non-directional*.

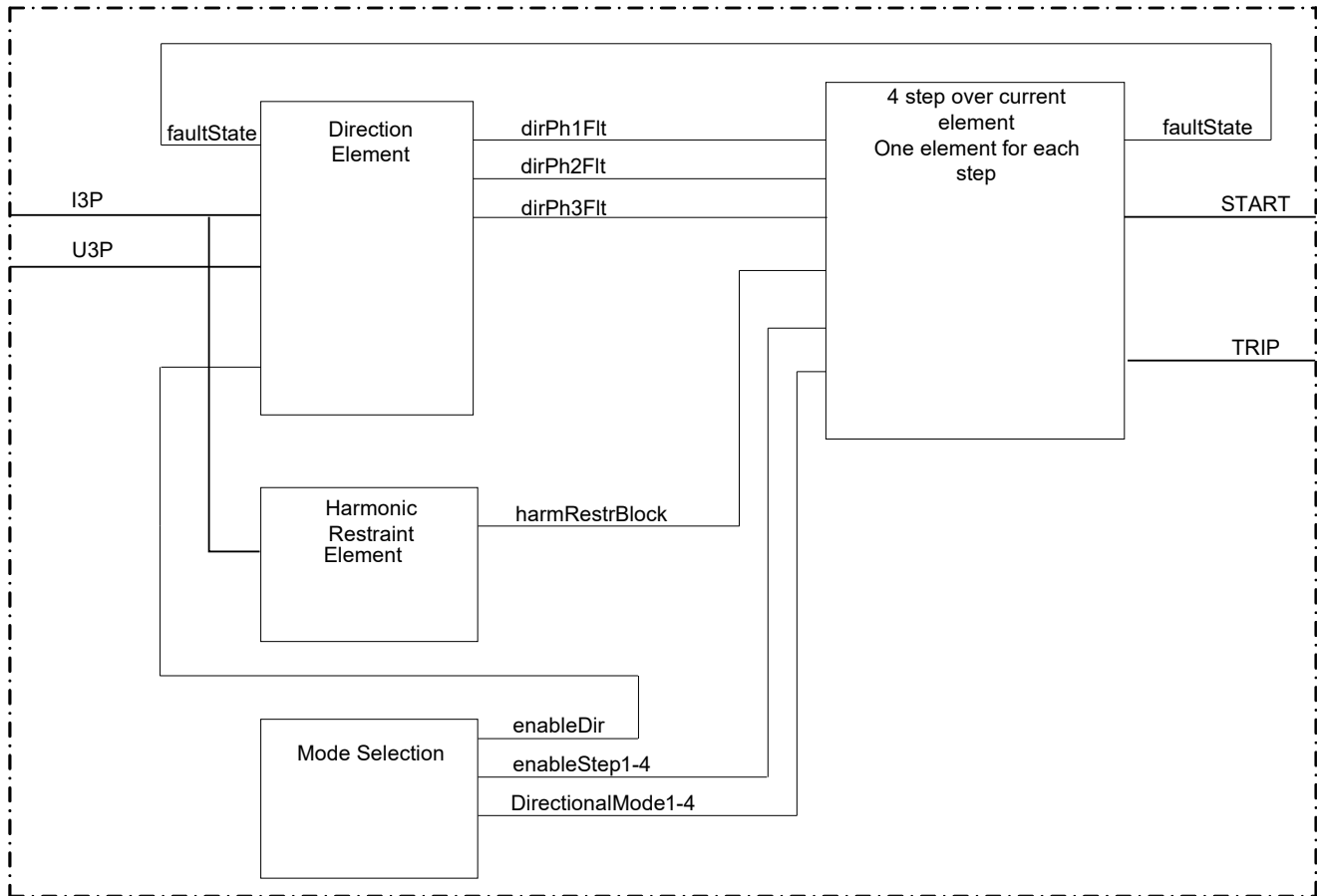

en05000740-2-en.vsd

Figure 31: Functional overview of OC4PTOC

The sampled analogue phase currents are processed in a pre-processing function block. Using a parameter setting *MeasType* within the general settings for the four step phase overcurrent protection 3-phase output function OC4PTOC, it is possible to select the type of the measurement used for all overcurrent stages. It is possible to select either discrete Fourier filter (DFT) or true RMS filter (RMS).

If DFT option is selected then only the RMS value of the fundamental frequency components of each phase current is derived. Influence of DC current component and higher harmonic current components are almost completely suppressed. If RMS option is selected then the true RMS values is used. The true RMS value in addition to the fundamental frequency component includes the contribution from the current DC component as well as from higher current harmonic. The selected current values are fed to OC4PTOC.

In a comparator, for each phase current, the DFT or RMS values are compared to the set operation current value of the function (*I1*, *I2*, *I3* or *I4*). If a phase current is larger than the set operation current, outputs **START**, **STx**, **STL1**, **STL2** and **STL3** are, without delay, activated. Output signals **STL1**, **STL2** and **STL3** are common for all steps. This means that the lowest set step will initiate the activation. The **START** signal is common for all three phases and all steps. It shall be noted that the selection of measured value (DFT or RMS) do not influence the operation of directional part of OC4PTOC.

Service value for individually measured phase currents are also available on the local HMI for OC4PTOC function, which simplifies testing, commissioning and in service operational checking of the function.

A harmonic restrain of the function can be chosen. A set 2nd harmonic current in relation to the fundamental current is used. The 2nd harmonic current is taken from the pre-processing of the phase currents and the relation is compared to a set restrain current level.

The function can be directional. The direction of the fault current is given as current angle in relation to the voltage angle. The fault current and fault voltage for the directional function is dependent of the fault type. To enable directional measurement at close in faults, causing low measured voltage, the polarization voltage is a combination of the apparent voltage (85%) and a memory voltage (15%). The following combinations are used.

Phase-phase short circuit:

$$U_{refL1L2} = U_{L1} - U_{L2} \quad I_{dirL1L2} = I_{L1} - I_{L2} \quad (\text{Equation 1})$$

$$U_{refL2L3} = U_{L2} - U_{L3} \quad I_{dirL2L3} = I_{L2} - I_{L3} \quad (\text{Equation 2})$$

$$U_{refL3L1} = U_{L3} - U_{L1} \quad I_{dirL3L1} = I_{L3} - I_{L1} \quad (\text{Equation 3})$$

Phase-earth short circuit:

$$U_{refL1} = U_{L1} \quad I_{dirL1} = I_{L1} \quad (\text{Equation 4})$$

$$U_{refL2} = U_{L2} \quad I_{dirL2} = I_{L2} \quad (\text{Equation 5})$$

$$U_{refL3} = U_{L3} \quad I_{dirL3} = I_{L3} \quad (\text{Equation 6})$$

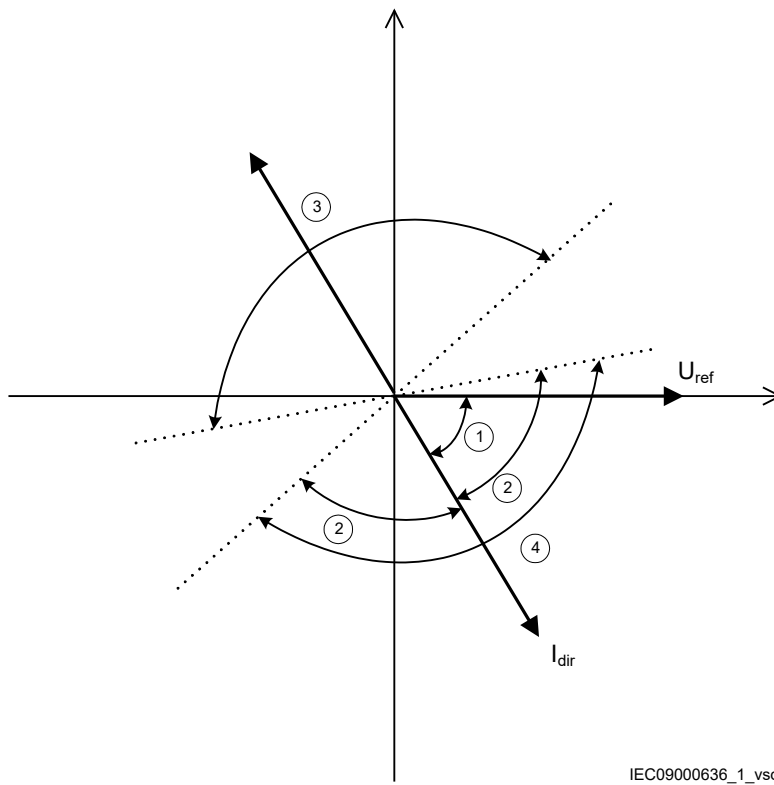

IEC09000636_1_vsd

Figure 32: Directional characteristic of the phase overcurrent protection

- 1 RCA = Relay characteristic angle 55°
- 2 ROA = Relay operating angle 80°
- 3 Reverse
- 4 Forward

If no blockings are given the start signals will start the timers of the step. The time characteristic for step 1 and 4 can be chosen as definite time delay or inverse time characteristic. Step 2 and 3 are always definite time delayed. A wide range of standardized inverse time characteristics is available. The possibilities for inverse time characteristics are described in section "[Inverse time characteristics](#)".

All four steps in OC4PTOC can be blocked from the binary input BLOCK. The binary input BLKSTx (x=1, 2, 3 or 4) blocks the operation of respective step.

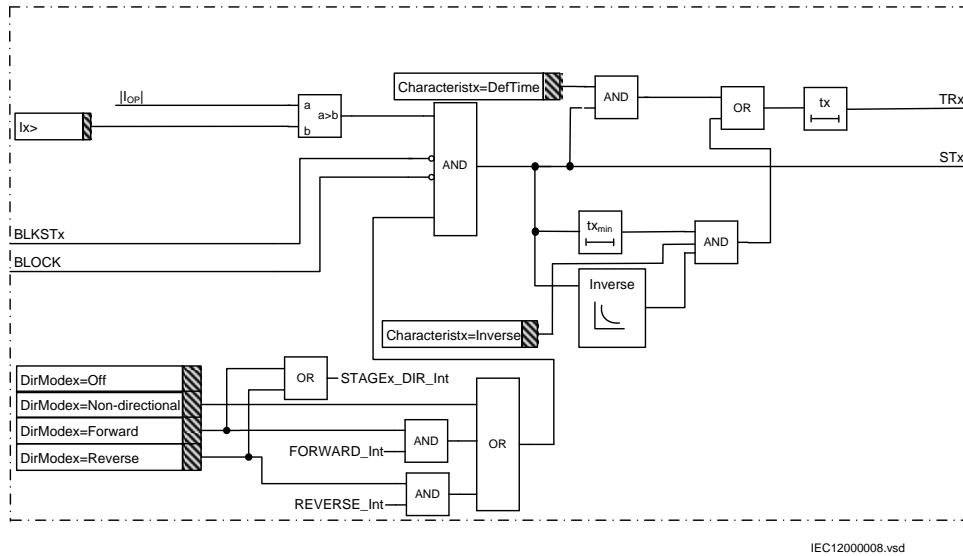

Figure 33: Simplified logic diagram for OC4PTOC

6.2.8 Second harmonic blocking element

A harmonic restrain of the Four step overcurrent protection function OC4PTOC can be chosen. Any of the four overcurrent stages can be selectively blocked by parameter *HarmRestrinx* setting. When second harmonic restraint feature is active, the OC4PTOC function output signal 2NDHARM will be set to logical value one if following conditions are fulfilled:

- Magnitude of fundamental frequency component in a phase current is above 7.0% IB
- Magnitude of second harmonic component in a phase current is above 7.0% IB
- Magnitude of second harmonic component in a phase current exceeds the preset level defined by the setting *2ndHarmStab* multiplied by the magnitude of fundamental frequency component in a phase current

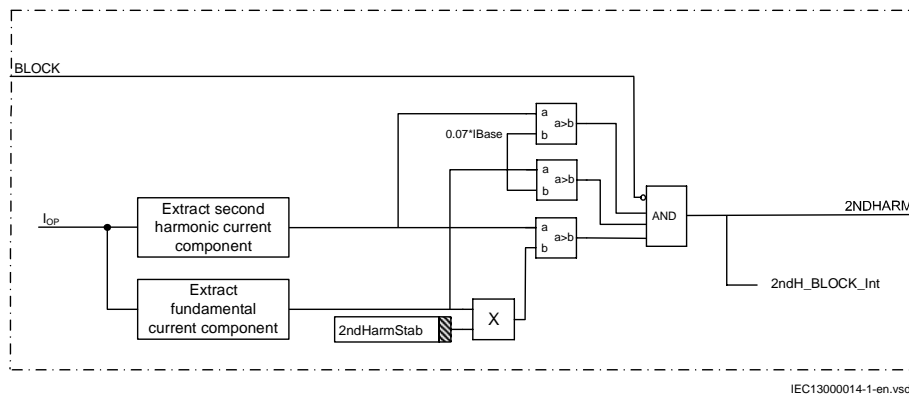

Figure 34: Second harmonic blocking

6.2.9 Technical data

Table 36: OC4PTOC technical data

Function	Setting range	Accuracy
Operate current	(5-2500)% of I_{Base}	$\pm 1.0\%$ of I_r at $I \leq I_r$ $\pm 1.0\%$ of I at $I > I_r$
Reset ratio	$> 95\%$ at (50–2500)% of I_{Base}	-
Min. operating current	(5-10000)% of I_{Base}	$\pm 1.0\%$ of I_r at $I \leq I_r$ $\pm 1.0\%$ of I at $I > I_r$
2nd harmonic blocking	(5–100)% of fundamental	$\pm 2.0\%$ of I_r
Independent time delay	(0.000-60.000) s	$\pm 0.5\% \pm 25$ ms
Minimum operate time for inverse characteristics	(0.000-60.000) s	$\pm 0.5\% \pm 25$ ms
Inverse characteristics, see table 573, table 574 and table 575	15 curve types	¹⁾ ANSI/IEEE C37.112 IEC 60255–151 $\pm 3\%$ or ± 40 ms $0.10 \leq k \leq 3.00$ $1.5 \times I_{set} \leq I \leq 20 \times I_{set}$
Operate time, nondirectional start function	25 ms typically at 0 to $2 \times I_{set}$	-
Reset time, nondirectional start function	35 ms typically at 2 to $0 \times I_{set}$	-
Operate time, directional start function	50 ms typically at 0 to $2 \times I_{set}$	-
Reset time, directional start function	35 ms typically at 2 to $0 \times I_{set}$	-
Critical impulse time	10 ms typically at 0 to $2 \times I_{set}$	-
Impulse margin time	15 ms typically	-
¹⁾ Note: Timing accuracy only valid when 2nd harmonic blocking is turned off		

6.3 Instantaneous residual overcurrent protection EFPIOC

6.3.1 Identification

Function description	IEC 61850 identification	IEC 60617 identification	ANSI/IEEE C37.2 device number
Instantaneous residual overcurrent protection	EFPIOC		50N

6.3.2 Functionality

The Instantaneous residual overcurrent protection EFPIOC has a low transient overreach and short tripping times to allow the use for instantaneous earth-fault protection, with the reach limited to less than the typical eighty percent of the line at minimum source impedance.

EFPIOC is configured to measure the residual current from the three-phase current inputs and can be configured to measure the current from a separate current input. EFPIOC can be blocked by activating the input BLOCK.

6.3.3 Function block

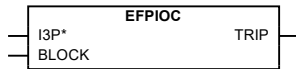

Figure 35: EFPIOC function block

6.3.4 Signals

Table 37: EFPIOC Input signals

Name	Type	Default	Description
I3P	GROUP SIGNAL	-	Three phase group signal for current inputs
BLOCK	BOOLEAN	0	Block of function

Table 38: EFPIOC Output signals

Name	Type	Description
TRIP	BOOLEAN	Trip signal

6.3.5 Settings

Table 39: EFPIOC Group settings (basic)

Name	Values (Range)	Unit	Step	Default	Description
Operation	Off On	-	-	Off	Operation Off / On
IN>>	1 - 2500	%IB	1	200	Operate residual current level in % of IBase

Table 40: EFPIOC Non group settings (basic)

Name	Values (Range)	Unit	Step	Default	Description
GlobalBaseSel	1 - 6	-	1	1	Selection of one of the Global Base Value groups

6.3.6 Monitored data

Table 41: EFPIOC Monitored data

Name	Type	Values (Range)	Unit	Description
IN	REAL	-	A	Residual current

6.3.7 Operation principle

The sampled analog residual currents are pre-processed in a discrete Fourier filter (DFT) block. From the fundamental frequency components of the residual current, as well as from the sample values the equivalent RMS value is derived. This current value is fed to the Instantaneous residual overcurrent protection (EFPIOC). In a comparator the RMS value is compared to the set operation current value of the function ($I_r > I_{set}$). If the residual current is larger than the set operation current a signal from the comparator is set to true. This signal will, without delay, activate the output signal TRIP.

6.3.8 Technical data

Table 42: EFPIOC technical data

Function	Range or value	Accuracy
Operate current	(1-2500)% of IBase	$\pm 1.0\%$ of I_r at $I \leq I_r$ $\pm 1.0\%$ of I at $I > I_r$
Reset ratio	> 95%	-
Operate time	20 ms typically at 0 to $2 \times I_{set}$	-
Reset time	30 ms typically at 2 to $0 \times I_{set}$	-
Critical impulse time	10 ms typically at 0 to $2 \times I_{set}$	-
Operate time	10 ms typically at 0 to $5 \times I_{set}$	-
Reset time	40 ms typically at 5 to $0 \times I_{set}$	-
Critical impulse time	2 ms typically at 0 to $5 \times I_{set}$	-
Dynamic overreach	< 5% at $\tau = 100$ ms	-

6.4 Four step residual overcurrent protection, zero, negative sequence direction EF4PTOC

6.4.1 Identification

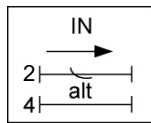
Function description	IEC 61850 identification	IEC 60617 identification	ANSI/IEEE C37.2 device number
Four step residual overcurrent protection, zero or negative sequence direction	EF4PTOC		51N/67N

6.4.2 Functionality

The four step residual overcurrent protection, zero or negative sequence direction (EF4PTOC) has a settable inverse or definite time delay independent for step 1 and 4 separately. Step 2 and 3 are always definite time delayed.

All IEC and ANSI inverse time characteristics are available.

EF4PTOC can be set directional or non-directional independently for each of the steps.

The directional part of the function can be set to operate on following combinations:

- Directional current (I3PDir) versus Polarizing voltage (U3PPol)
- Directional current (I3PDir) versus Polarizing current (I3PPol)
- Directional current (I3PDir) versus Dual polarizing (UPol+ZPol x IPol) where ZPol = RPol + jXPol

IDir, UPol and IPol can be independently selected to be either zero sequence or negative sequence.



Other setting combinations are possible, but not recommended.

Second harmonic blocking level can be set for the function and can be used to block each step individually.

EF4PTOC can be used as main protection for phase-to-earth faults.

EF4PTOC can also be used to provide a system back-up for example, in the case of the primary protection being out of service due to communication or voltage transformer circuit failure.

Directional operation can be combined together with corresponding communication logic in permissive or blocking teleprotection scheme. Current reversal and weak-end infeed functionality are available as well.

6.4.3 Function block

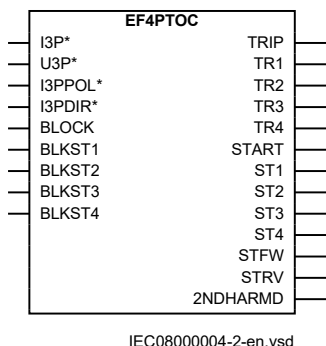

Figure 36: EF4PTOC function block

6.4.4 Signals

Table 43: EF4PTOC Input signals

Name	Type	Default	Description
I3P	GROUP SIGNAL	-	Three phase group signal for current inputs
U3P	GROUP SIGNAL	-	Three phase group signal for polarizing voltage inputs
I3PPOL	GROUP SIGNAL	-	Three phase group signal for polarizing current inputs

Table continues on next page

Name	Type	Default	Description
I3PDIR	GROUP SIGNAL	-	Three phase group signal for operating directional inputs
BLOCK	BOOLEAN	0	Block of function
BLKST1	BOOLEAN	0	Block of step 1 (start and trip)
BLKST2	BOOLEAN	0	Block of step 2 (start and trip)
BLKST3	BOOLEAN	0	Block of step 3 (start and trip)
BLKST4	BOOLEAN	0	Block of step 4 (start and trip)

Table 44: EF4PTOC Output signals

Name	Type	Description
TRIP	BOOLEAN	General trip signal
TR1	BOOLEAN	Trip signal from step 1
TR2	BOOLEAN	Trip signal from step 2
TR3	BOOLEAN	Trip signal from step 3
TR4	BOOLEAN	Trip signal from step 4
START	BOOLEAN	General start signal
ST1	BOOLEAN	Start signal step 1
ST2	BOOLEAN	Start signal step 2
ST3	BOOLEAN	Start signal step 3
ST4	BOOLEAN	Start signal step 4
STFW	BOOLEAN	Forward directional start signal
STRV	BOOLEAN	Reverse directional start signal
2NDHARMD	BOOLEAN	2nd harmonic block signal

6.4.5 Settings

Table 45: EF4PTOC Group settings (basic)

Name	Values (Range)	Unit	Step	Default	Description
Operation	Off On	-	-	Off	Operation Off / On
EnaDir	Disable Enable	-	-	Enable	Enabling the Directional calculation
AngleRCA	-180 - 180	Deg	1	65	Relay characteristic angle (RCA)
polMethod	Voltage Current Dual	-	-	Voltage	Type of polarization
UPolMin	1 - 100	%UB	1	1	Minimum voltage level for polarization (UN or U2) in % of UBase
IPolMin	2 - 100	%IB	1	5	Minimum current level for polarization (IN or I2) in % of IBase
RPol	0.50 - 1000.00	ohm	0.01	5.00	Real part of source Z to be used for current polarisation

Table continues on next page

Name	Values (Range)	Unit	Step	Default	Description
XPol	0.50 - 3000.00	ohm	0.01	40.00	Imaginary part of source Z to be used for current polarisation
I>Dir	1 - 100	%IB	1	10	Current level (I _N or I ₂) for direction release in % of IBase
2ndHarmStab	5 - 100	%	1	20	Second harmonic restrain operation in % of I _N amplitude
DirMode1	Off Non-directional Forward Reverse	-	-	Non-directional	Directional mode of step 1 (off, non-directional, forward, reverse)
Characterist1	ANSI Ext. inv. ANSI Very inv. ANSI Norm. inv. ANSI Mod. inv. ANSI Def. Time L.T.E. inv. L.T.V. inv. L.T. inv. IEC Norm. inv. IEC Very inv. IEC inv. IEC Ext. inv. IEC S.T. inv. IEC L.T. inv. IEC Def. Time Reserved RI type RD type	-	-	ANSI Def. Time	Time delay curve type for step 1
I _{N1} >	1 - 2500	%IB	1	100	Operate residual current level for step 1 in % of IBase
t ₁	0.000 - 60.000	s	0.001	0.000	Independent (definite) time delay of step 1
k ₁	0.05 - 999.00	-	0.01	0.05	Time multiplier for the dependent time delay for step 1
I _{Min1}	1 - 10000	%IB	1	100	Minimum operate current for step1 in % of IBase
t _{1Min}	0.000 - 60.000	s	0.001	0.000	Minimum operate time for inverse curves for step 1
HarmRestrain1	Off On	-	-	On	Enable block of step 1 from harmonic restrain
DirMode2	Off Non-directional Forward Reverse	-	-	Non-directional	Directional mode of step 2 (off, non-directional, forward, reverse)
I _{N2} >	1 - 2500	%IB	1	50	Operate residual current level for step 2 in % of IBase
t ₂	0.000 - 60.000	s	0.001	0.400	Independent (definite) time delay of step 2
I _{Min2}	1 - 10000	%IB	1	50	Minimum operate current for step 2 in % of IBase
HarmRestrain2	Off On	-	-	On	Enable block of step 2 from harmonic restrain
DirMode3	Off Non-directional Forward Reverse	-	-	Non-directional	Directional mode of step 3 (off, non-directional, forward, reverse)
I _{N3} >	1 - 2500	%IB	1	33	Operate residual current level for step 3 in % of IBase

Table continues on next page

Name	Values (Range)	Unit	Step	Default	Description
t3	0.000 - 60.000	s	0.001	0.800	Independent (definite) time delay of step 3
IMin3	1 - 10000	%IB	1	33	Minimum operate current for step 3 in % of IBase
HarmRestrained3	Off On	-	-	On	Enable block of step 3 from harmonic restrain
DirMode4	Off Non-directional Forward Reverse	-	-	Non-directional	Directional mode of step 4 (off, non-directional, forward, reverse)
Characterist4	ANSI Ext. inv. ANSI Very inv. ANSI Norm. inv. ANSI Mod. inv. ANSI Def. Time L.T.E. inv. L.T.V. inv. L.T. inv. IEC Norm. inv. IEC Very inv. IEC inv. IEC Ext. inv. IEC S.T. inv. IEC L.T. inv. IEC Def. Time Reserved RI type RD type	-	-	ANSI Def. Time	Time delay curve type for step 4
IN4>	1 - 2500	%IB	1	17	Operate residual current level for step 4 in % of IBase
t4	0.000 - 60.000	s	0.001	1.200	Independent (definite) time delay of step 4
k4	0.05 - 999.00	-	0.01	0.05	Time multiplier for the dependent time delay for step 4
IMin4	1 - 10000	%IB	1	17	Minimum operate current for step 4 in % of IBase
t4Min	0.000 - 60.000	s	0.001	0.000	Minimum operate time in inverse curves step 4
HarmRestrained4	Off On	-	-	On	Enable block of step 4 from harmonic restrain

Table 46: EF4PTOC Non group settings (basic)

Name	Values (Range)	Unit	Step	Default	Description
GlobalBaseSel	1 - 6	-	1	1	Selection of one of the Global Base Value groups
SeqTypeUPol	ZeroSeq NegSeq	-	-	ZeroSeq	Choice of measurand for polarizing voltage
SeqTypeIPol	ZeroSeq NegSeq	-	-	ZeroSeq	Choice of measurand for polarizing current
SeqTypeIDir	ZeroSeq NegSeq	-	-	ZeroSeq	Choice of measurand for directional current

6.4.6 Monitored data

Table 47: EF4PTOC Monitored data

Name	Type	Values (Range)	Unit	Description
STDIR	INTEGER	3=Both 1=Forward 2=Reverse 0=No direction	-	Fault direction coded as integer
IOP	REAL	-	A	Operating current level
UPol	REAL	-	kV	Polarizing voltage level
IPol	REAL	-	A	Polarizing current level
UPOLIANG	REAL	-	deg	Angle between polarizing voltage and operating current
IPOLIANG	REAL	-	deg	Angle between polarizing current and operating current
IOPDIR	REAL	-	A	Amplitude of the directional operating quantity

6.4.7 Operation principle

Four step residual overcurrent protection, zero or negative sequence direction EF4PTOC function has the following four “Analog Inputs” on its function block in the configuration tool:

1. I3P, input used for “Operating Quantity”.
2. U3P, input used for “Voltage Polarizing Quantity”.
3. I3PPOL, input used for “Current Polarizing Quantity”.
4. I3PDIR, input used for “Operating Directional Quantity”.

These inputs are connected from the corresponding pre-processing function blocks in the Configuration Tool within PCM600.

6.4.7.1 Operating quantity within the function

If the function is set to measure zero sequence, it uses Residual Current ($3I_0$) for its operating quantity. The residual current can be:

1. directly measured (when a dedicated CT input of the IED is connected in PCM600 to the fourth analog input of the pre-processing block connected to EF4PTOC function input I3P). This dedicated IED CT input can be for example, connected to:
 - parallel connection of current instrument transformers in all three phases (Holm-Green connection).
 - one single core balance, current instrument transformer (cable CT).
 - one single current instrument transformer located between power system star point and earth (that is, current transformer located in the star point of a star connected transformer winding).
 - one single current instrument transformer located between two parts of a protected object (that is, current transformer located between two star points of double star shunt capacitor bank).
2. calculated from three-phase current input within the IED (when the fourth analog input into the pre-processing block connected to EF4PTOC function Analog Input I3P is not connected to a dedicated CT input of the IED in PCM600). In such case the pre-processing block will calculate $3I_0$ from the first three inputs into the pre-processing block by using

the following formula (will take I2 from same SMAI AI3P connected to I3PDIR input (same SMAI AI3P connected to I3P input)):

If zero sequence current is selected,

$$I_{op} = 3I_0 = IL1 + IL2 + IL3$$

(Equation 7)

where:

IL1, IL2 and IL3 are fundamental frequency phasors of three individual phase currents.

The residual current is pre-processed by a discrete Fourier filter. Thus the phasor of the fundamental frequency component of the residual current is derived. The phasor magnitude is used within the EF4PTOC protection to compare it with the set operation current value of the four steps (*IN1*>, *IN2*>, *IN3*> or *IN4*>). If the residual current is larger than the set operation current and the step is used in non-directional mode a signal from the comparator for this step is set to true. This signal will, without delay, activate the output signal STx (x=step 1-4) for this step and a common START signal.

6.4.7.2 Internal polarizing

A polarizing quantity is used within the protection in order to determine the direction to the earth fault (Forward/Reverse).

The function can be set to use voltage polarizing, current polarizing or dual polarizing.

Voltage polarizing

When voltage polarizing is selected the protection will use either the residual voltage $3U_0$ or the negative sequence voltage U_2 as polarizing quantity U3P.

The residual voltage can be:

1. directly measured (when a dedicated VT input of the IED is connected in PCM600 to the fourth analog input of the pre-processing block connected to EF4PTOC function input U3P). This dedicated IED VT input shall be then connected to open delta winding of a three phase main VT.
2. calculated from three phase voltage input within the IED (when the fourth analog input into the pre-processing block connected to EF4PTOC analog function input U3P is NOT connected to a dedicated VT input of the IED in PCM600). In such case the pre-processing block will calculate $3U_0$ from the first three inputs into the pre-processing block by using the following formula:

$$UPol = 3U_0 = (UL1 + UL2 + UL3)$$

(Equation 9)

where:

UL1, UL2 and UL3 are fundamental frequency phasors of three individual phase voltages.



In order to use this, all three phase-to-earth voltages must be connected to three IED VT inputs.

The residual voltage is pre-processed by a discrete fourier filter. Thus, the phasor of the fundamental frequency component of the residual voltage is derived.

The negative sequence voltage is calculated from the three-phase voltage input within the IED by using the pre-processing block. The preprocessing block will calculate the negative sequence voltage from the three inputs into the pre-processing block by using the following formula:

$$U_2 = (UL1 + \alpha \cdot UL2 + \alpha^2 \cdot UL3) / 3 \quad (\text{Equation 10})$$

where:

UL1, UL2 and UL3 are fundamental frequency phasors of three individual phase voltages.
alpha unit phasor with an angle of 120 degrees.

The polarizing phasor is used together with the phasor of the operating directional current, in order to determine the direction to the earth fault (Forward/Reverse). In order to enable voltage polarizing the magnitude of polarizing voltage shall be bigger than a minimum level defined by setting parameter *UpolMin*.

It shall be noted that residual voltage (U_n) or negative sequence voltage (U_2) is used to determine the location of the earth fault. This insures the required inversion of the polarizing voltage within the earth-fault function.

Current polarizing

When current polarizing is selected the function will use an external residual current ($3I_0$) or the calculated negative sequence current (I_2) as polarizing quantity *IPol*. The user can select the required current.

The residual current can be:

1. directly measured (when a dedicated CT input of the IED is connected in PCM600 to the fourth analog input of the pre-processing block connected to EF4PTOC function input I3PPOL). This dedicated IED CT input is then typically connected to one single current transformer located between power system star point and earth (current transformer located in the star point of a star connected transformer winding).
 - For some special line protection applications this dedicated IED CT input can be connected to parallel connection of current transformers in all three phases (Holm-Green connection).
2. calculated from three phase current input within the IED (when the fourth analog input into the pre-processing block connected to EF4PTOC function analog input I3PPOL is NOT connected to a dedicated CT input of the IED in PCM600). In such case the pre-processing block will calculate $3I_0$ from the first three inputs into the pre-processing block by using the following formula:

$$IPol = 3I_0 = IL1 + IL2 + IL3 \quad (\text{Equation 11})$$

where:

IL1, IL2 and IL3 are fundamental frequency phasors of three individual phase currents.

The negative sequence current can be calculated from the three-phase current input within the IED by using the pre-processing block. The pre-processing block will calculate the negative

sequence current from the three inputs into the pre-processing block by using the following formula:

$$I2 = (IL1 + \alpha^2 \cdot IL2 + \alpha \cdot IL3) / 3$$

(Equation 12)

where:

IL1, IL2 and IL3 are fundamental frequency phasors of three individual phase currents.

alpha phasor with an angle of 120 degrees.

The polarizing current is pre-processed by a discrete fourier filter. Thus the phasor of the fundamental frequency component of the polarizing current is derived. This phasor is then multiplied with pre-set equivalent zero-sequence source Impedance in order to calculate equivalent polarizing voltage UIPol in accordance with the following formula:

$$UIPol = Z_{0s} \cdot IPol = (RNPOL + j \cdot XNPOL) \cdot IPol$$

(Equation 13)

which will be then used, together with the phasor of the operating directional current, in order to determine the direction to the earth fault (Forward/Reverse).

In order to enable current polarizing the magnitude of polarizing current shall be bigger than a minimum level defined by setting parameter *IPolMin*.

Dual polarizing

When dual polarizing is selected the function will use the vectorial sum of the voltage based and current based polarizing in accordance with the following formula:

$$UTotPol = UUPol + UIPol = UPol + Z_{0s} \cdot IPol = UPol + (RNPOL + jXNPOL) \cdot IPol$$

(Equation 14)

Upol and Ipol can be either zero sequence component or negative sequence component depending upon the user selection.

Then the phasor of the total polarizing voltage UTotPol will be used, together with the phasor of the operating current, to determine the direction of the earth fault (Forward/Reverse).

6.4.7.3 External polarizing for earth-fault function

The individual steps within the protection can be set as non-directional. When this setting is selected it is then possible via function binary input BLKSTx (where x indicates the relevant step within the protection) to provide external directional control (that is, torque control) by for example using one of the following functions if available in the IED:

1. Distance protection directional function.
2. Negative sequence based overcurrent function.

6.4.7.4 Base quantities within the protection

The base quantities are entered as global settings for all functions in the IED. Base current (*IBase*) shall be entered as rated phase current of the protected object in primary amperes. Base voltage (*UBase*) shall be entered as rated phase-to-phase voltage of the protected object in primary kV.

6.4.7.5 Internal earth-fault protection structure

The protection is internally divided into the following parts:

1. Four residual overcurrent steps.
2. Directional supervision element for residual overcurrent steps with integrated directional comparison step for communication based earth-fault protection schemes (permissive or blocking).
3. Second harmonic blocking element with additional feature for sealed-in blocking during switching of parallel transformers.

Each part is described separately in the following sections.

6.4.7.6 Four residual overcurrent steps

Each overcurrent step uses operating quantity I_{op} (residual current) as measuring quantity. Each of the four residual overcurrent steps has the following built-in facilities:

- Directional mode can be set to *Off/ Non-directional/ Forward/ Reverse*. By this parameter setting the directional mode of the step is selected. It shall be noted that the directional decision (Forward/Reverse) is not made within each residual overcurrent step itself. The direction of the fault is determined in a directional element common for all steps.
- Residual current start value.
- Type of operating characteristic. By this parameter setting it is possible to select inverse or definitive time delay for step 1 and 4 separately. Step 2 and 3 are always definite time delayed. All of the standard IEC and ANSI inverse characteristics are available. For the complete list of available inverse curves please refer to section "[Inverse time characteristics](#)".
- Time delay related settings. By these parameter settings the properties like definite time delay, minimum operating time for inverse curves and reset time delay are defined.
- Supervision by second harmonic blocking feature (*On/ Off*). By this parameter setting it is possible to prevent operation of the step if the second harmonic content in the residual current exceeds the preset level.

Simplified logic diagram for one residual overcurrent step is shown in figure 37.

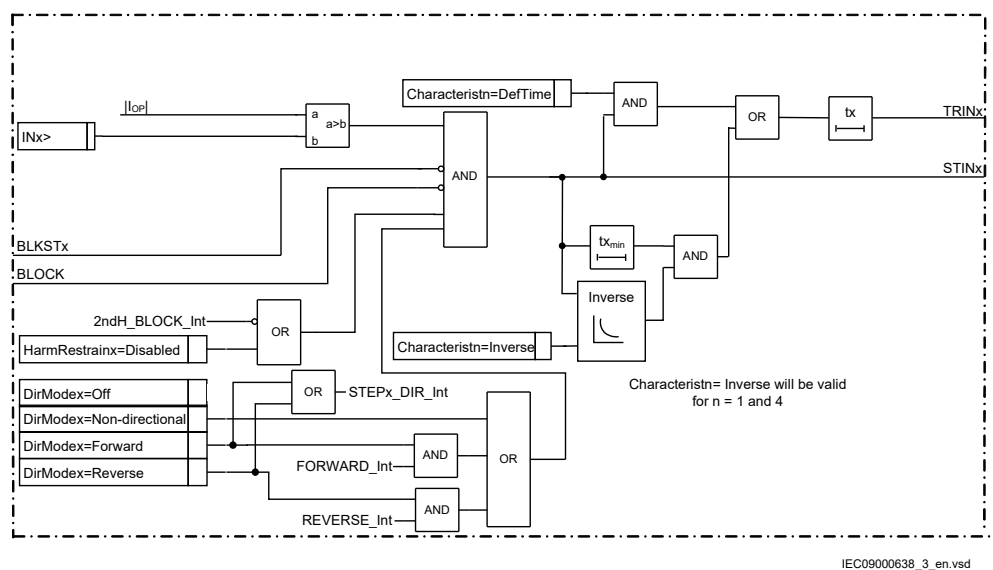

Figure 37: Simplified logic diagram for residual overcurrent

The protection can be completely blocked from the binary input BLOCK. Output signals for respective step, STx and TRx and , can be blocked from the binary input BLKSTx.

6.4.7.7 Directional supervision element with integrated directional comparison function



It shall be noted that at least one of the four residual overcurrent steps shall be set as directional in order to enable execution of the directional supervision element and the integrated directional comparison function.

The protection has integrated directional feature. The operating quantity current I_{3PDIR} is always used. The polarizinwgc method is determined by the parameter setting *polMethod*. The polarizing quantity will be selected by the function in one of the following three ways:

1. When *polMethod* = *Voltage*, UPol will be used as polarizing quantity.
2. When *polMethod* = *Current*, IPol will be used as polarizing quantity.
3. When *polMethod* = *Dual*, UPol + IPol · ZNPOL will be used as polarizing quantity.

The operating and polarizing quantity are then used inside the directional element, as shown in figure 38, in order to determine the direction of the earth fault.

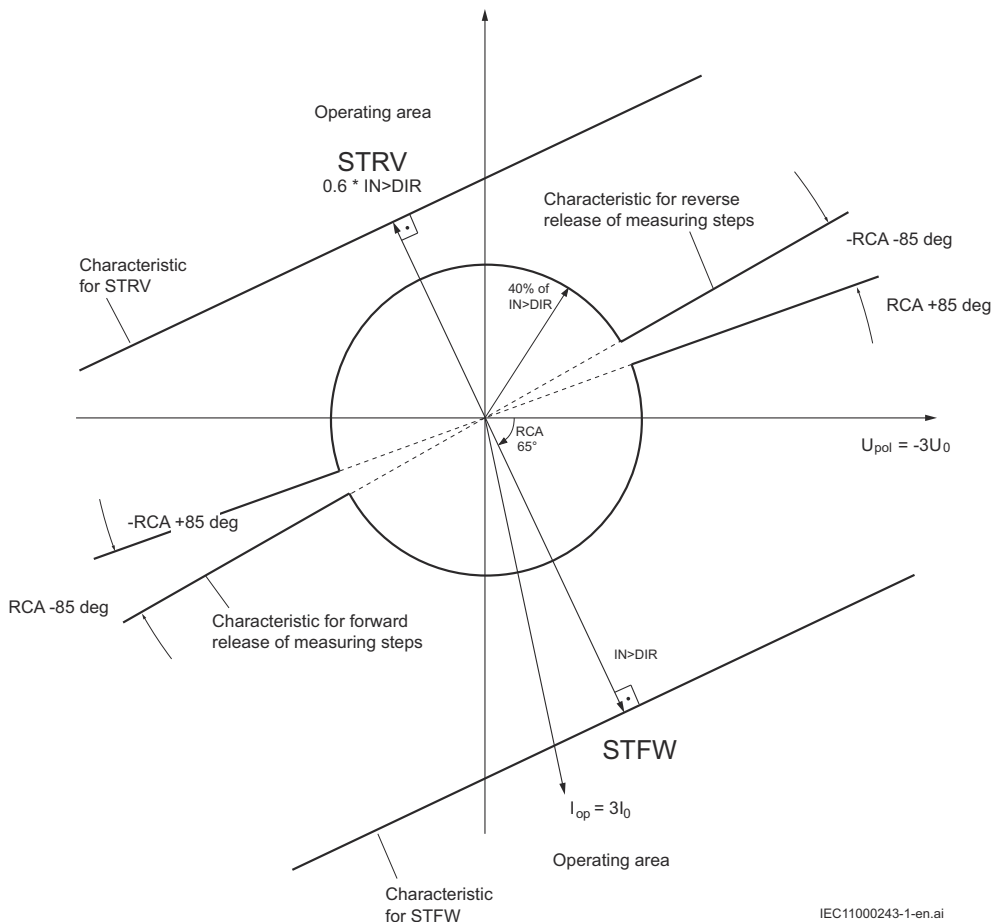

Figure 38: Operating characteristic for earth-fault directional element using the zero sequence components

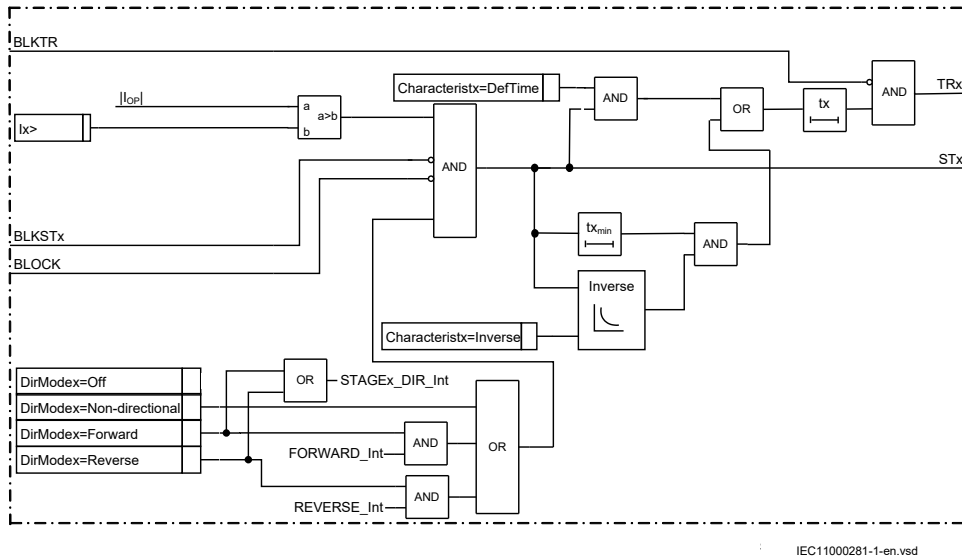

Figure 39: Operating characteristic for earth-fault directional element using the zero sequence components

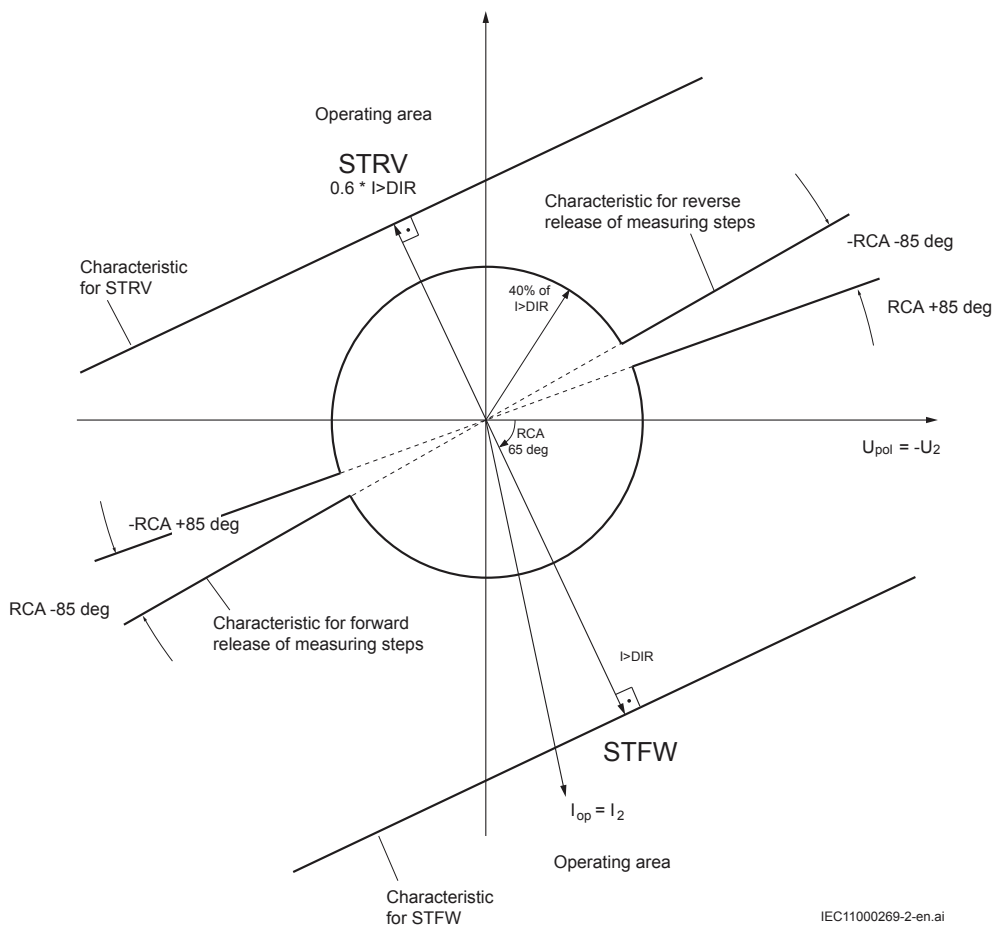

Figure 40: Operating characteristic for earth-fault directional element using the negative sequence components

Two relevant setting parameters for directional supervision element are:

- Directional element will be internally enabled to operate as soon as I_{op} is bigger than 40% of $I_{>Dir}$ and directional condition is fulfilled in set direction.
- Relay characteristic angle $AngleRCA$, which defines the position of forward and reverse areas in the operating characteristic.

Directional comparison step, built-in within directional supervision element, will set EF4PTOC function output binary signals:

1. STFW=1 when operating quantity magnitude $I_{op} \times \cos(\phi - AngleRCA)$ is bigger than setting parameter $I_{>Dir}$ and directional supervision element detects fault in forward direction.
2. STRV=1 when operating quantity magnitude $I_{op} \times \cos(\phi - AngleRCA)$ is bigger than 60% of setting parameter $I_{>Dir}$ and directional supervision element detects fault in reverse direction.

These signals shall be used for communication based earth-fault teleprotection communication schemes (permissive or blocking).

Simplified logic diagram for directional supervision element with integrated directional comparison step is shown in figure 41:

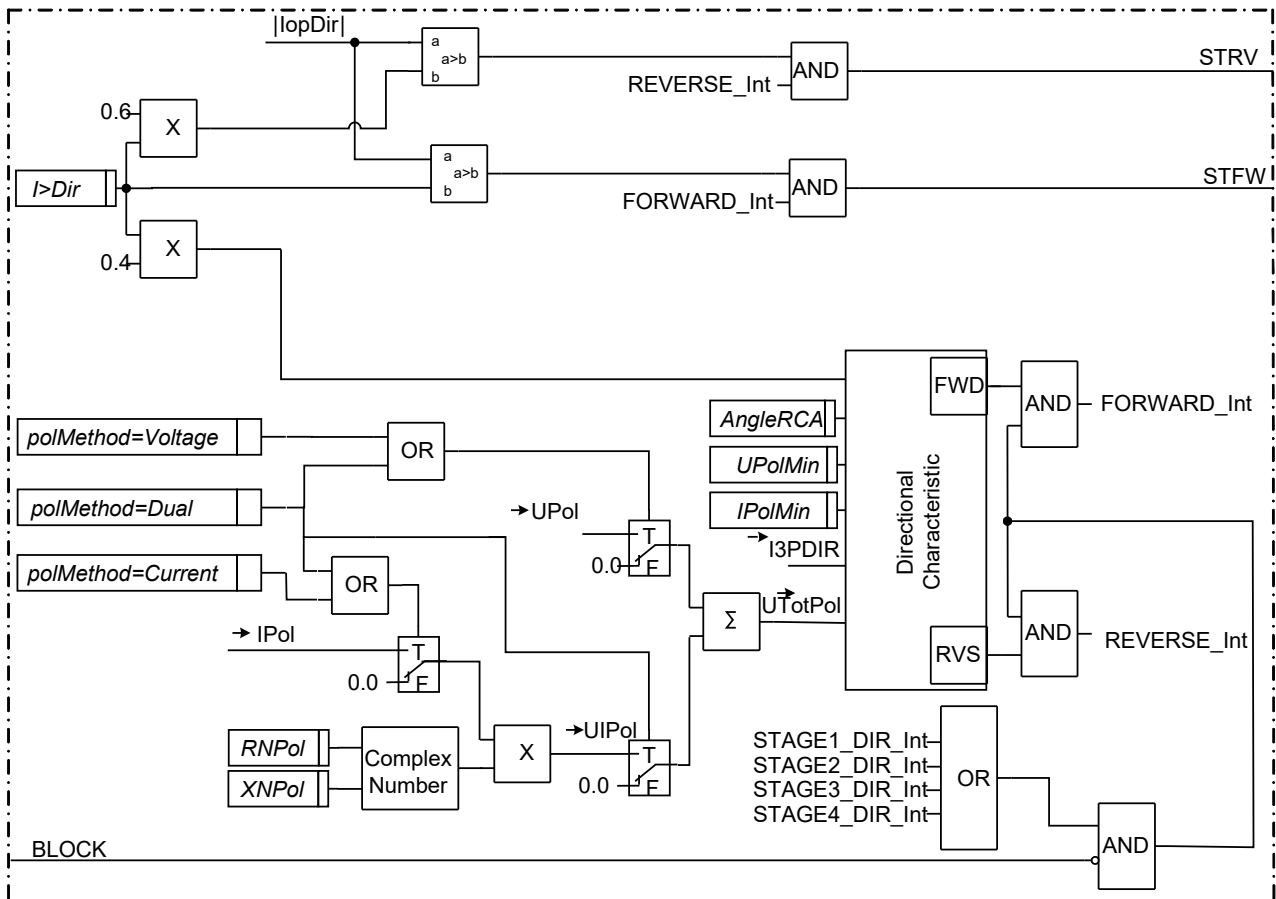

IEC07000067-5-en.vsd

Figure 41: Simplified logic diagram for directional supervision element with integrated directional comparison step

6.4.8 Second harmonic blocking element

A harmonic restrain of the Four step residual overcurrent protection function EF4PTOC can be chosen. Any of the four residual overcurrent stages can be selectively blocked by parameter *HarmRestrainx* setting. When second harmonic restraint feature is active, the EF4PTOC function output signal 2NDHARMD will be set to logical value one if following conditions are fulfilled:

- Magnitude of fundamental frequency component in a phase current is above 7.0% I_B
- Magnitude of second harmonic component in a residual current is above 7.0% I_B
- Magnitude of second harmonic component in a residual current exceeds the preset level defined by a setting *2ndHarmStab* multiplied by the magnitude of fundamental frequency component in a residual current.

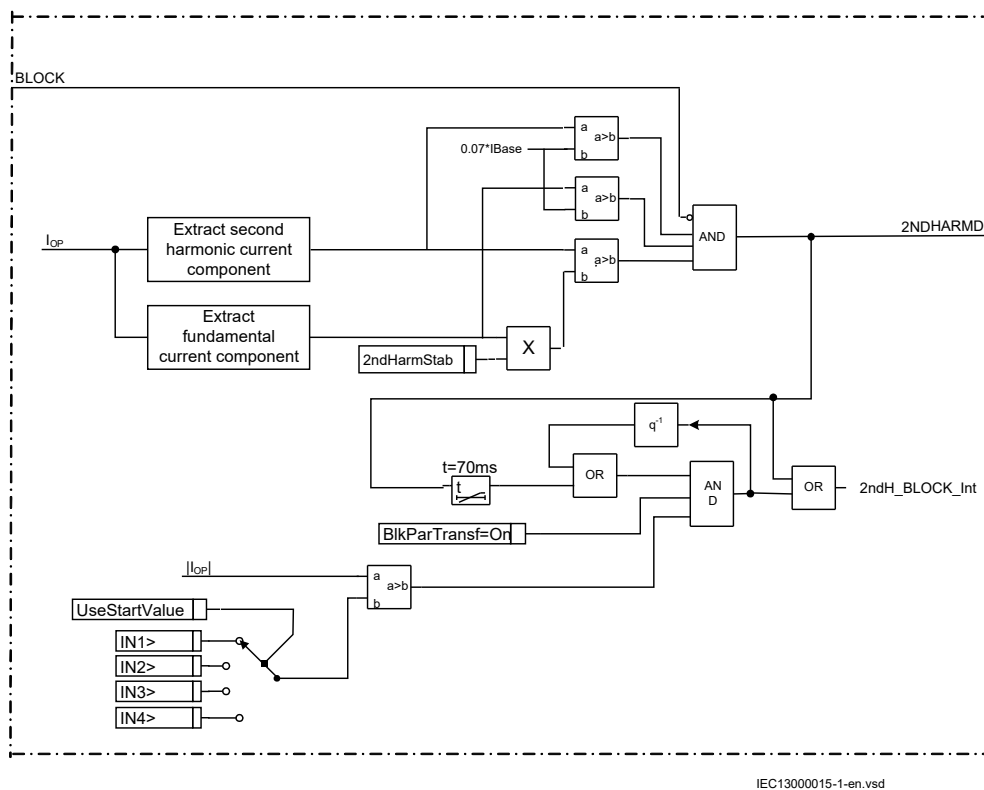

Figure 42: Second harmonic blocking

6.4.9 Technical data

Table 48: EF4PTOC technical data

Function	Range or value	Accuracy
Operate current	(1-2500)% of I_{Base}	$\pm 1.0\%$ of I_r at $I < I_r$ $\pm 1.0\%$ of I at $I > I_r$
Reset ratio	> 95%	-
Operate current for directional comparison, Zero sequence	(1-100)% of I_{Base}	$\pm 2.0\%$ of I_r
Operate current for directional comparison, Negative sequence	(1-100)% of I_{Base}	$\pm 2.0\%$ of I_r
Table continues on next page		

Function	Range or value	Accuracy
Min. operating current	(1-10000)% of I_{Base}	$\pm 1.0\%$ of I_r at $I < I_r$ $\pm 1.0\%$ of I at $I > I_r$
Minimum operate time for inverse characteristics	(0.000-60.000) s	$\pm 0.5\% \pm 25$ ms
Timers	(0.000-60.000) s	$\pm 0.5\% \pm 25$ ms
Inverse characteristics, see table 573, table 574 and table 575	15 curve types	¹⁾ ANSI/IEEE C37.112 IEC 60255-151 $\pm 3\%$ or ± 40 ms $0.10 \leq k \leq 3.00$ $1.5 \times I_{set} \leq I \leq 20 \times I_{set}$
Minimum polarizing voltage, Zero sequence	(1-100)% of U_{Base}	$\pm 0.5\%$ of U_r
Minimum polarizing voltage, Negative sequence	(1-100)% of U_{Base}	$\pm 0.5\%$ of U_r
Minimum polarizing current, Zero sequence	(2-100)% of I_{Base}	$\pm 1.0\%$ of I_r
Minimum polarizing current, Negative sequence	(2-100)% of I_{Base}	$\pm 1.0\%$ of I_r
Real part of source Z used for current polarization	(0.50-1000.00) Ω /phase	-
Imaginary part of source Z used for current polarization	(0.50-3000.00) Ω /phase	-
Operate time, non-directional start function	30 ms typically at 0.5 to $2 \times I_{set}$	-
Reset time, non-directional start function	30 ms typically at 2 to $0.5 \times I_{set}$	-
Operate time, directional start function	30 ms typically at $0,5$ to $2 \times I_N$	-
Reset time, directional start function	30 ms typically at 2 to $0,5 \times I_N$	-
¹⁾ Note: Timing accuracy only valid when 2nd harmonic blocking is turned off.		

6.5 Sensitive directional residual overcurrent and power protection SDEPSDE

6.5.1 Identification

Function description	IEC 61850 identification	IEC 60617 identification	ANSI/IEEE C37.2 device number
Sensitive directional residual over current and power protection	SDEPSDE	-	67N

6.5.2 Functionality

In isolated networks or in networks with high impedance earthing, the earth fault current is significantly smaller than the short circuit currents. In addition to this, the magnitude of the fault current is almost independent on the fault location in the network. The protection can be

selected to use either the residual current, $3I_0 \cdot \cos \varphi$ or $3I_0 \cdot \varphi$, or residual power component $3U_0 \cdot 3I_0 \cdot \cos \varphi$, for operating quantity. There is also available one non-directional $3I_0$ step and one non-directional $3U_0$ overvoltage tripping step.

6.5.3 Function block

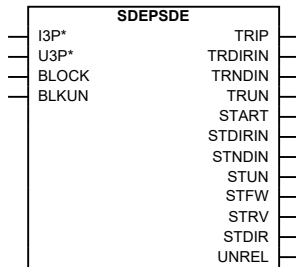

Figure 43: SDEPSDE function block

6.5.4 Signals

Table 49: SDEPSDE Input signals

Name	Type	Default	Description
I3P	GROUP SIGNAL	-	Three phase group signal for current inputs
U3P	GROUP SIGNAL	-	Three phase group signal for voltage inputs
BLOCK	BOOLEAN	0	Block of function
BLKUN	BOOLEAN	0	Blocks the non-directional voltage residual outputs

Table 50: SDEPSDE Output signals

Name	Type	Description
TRIP	BOOLEAN	General trip signal
TRDIRIN	BOOLEAN	Trip of the directional residual overcurrent
TRNDIN	BOOLEAN	Trip of non-directional residual overcurrent
TRUN	BOOLEAN	Trip of non-directional residual overvoltage
START	BOOLEAN	General start signal
STDIRIN	BOOLEAN	Start of the directional residual overcurrent function
STNDIN	BOOLEAN	Start of non directional residual overcurrent
STUN	BOOLEAN	Start of non directional residual overvoltage
STFW	BOOLEAN	Start of directional function for fault in forward direction
STRV	BOOLEAN	Start of directional function for fault in reverse direction
STDIR	INTEGER	Direction of fault
UNREL	BOOLEAN	Residual voltage release of operation of directional modes

6.5.5 Settings

Table 51: SDEPSDE Group settings (basic)

Name	Values (Range)	Unit	Step	Default	Description
Operation	Off On	-	-	Off	Operation Off / On
OpMode	3I0Cosfi 3I03U0Cosfi 3I0 and fi	-	-	3I0Cosfi	Selection of operation mode for protection
DirMode	Forward Reverse	-	-	Forward	Direction of operation forward or reverse
RCADir	-179 - 180	Deg	1	-90	Relay characteristic angle RCA
RCAComp	-10.0 - 10.0	Deg	0.1	0.0	Relay characteristic angle compensation
ROADir	0 - 90	Deg	1	90	Relay open angle ROA used as release in phase mode
INCosPhi>	0.25 - 200.00	%IB	0.01	1.00	Set level for 3I0cosPhi, directional residual overcurrent, in % of IBase
SN>	0.25 - 200.00	%SB	0.01	10.00	Set level for 3I0U0cosPhi, starting inverse time count, in % of SBase
INDir>	0.25 - 200.00	%IB	0.01	5.00	Set level for directional residual overcurrent protection, in % of IBase
tDef	0.000 - 60.000	s	0.001	0.100	Definite time delay directional residual overcurrent
SRef	0.03 - 200.00	%SB	0.01	10.00	Reference value of residual power for inverse time count, in % of SBase
kSN	0.00 - 2.00	-	0.01	0.10	Time multiplier setting for directional residual power mode
OpINNonDir>	Off On	-	-	Off	Operation of non-directional residual overcurrent protection
INNonDir>	1.00 - 400.00	%IB	0.01	10.00	Set level for non-directional residual overcurrent, in % of IBase
tINNonDir	0.000 - 60.000	s	0.001	1.000	Time delay for non-directional residual overcurrent
TimeChar	ANSI Ext. inv. ANSI Very inv. ANSI Norm. inv. ANSI Mod. inv. ANSI Def. Time L.T.E. inv. L.T.V. inv. L.T. inv. IEC Norm. inv. IEC Very inv. IEC inv. IEC Ext. inv. IEC S.T. inv. IEC L.T. inv. IEC Def. Time Reserved RI type RD type	-	-	IEC Norm. inv.	Operation curve selection for IDMT operation
tMin	0.000 - 60.000	s	0.001	0.040	Minimum operate time for IEC IDMT curves
kIN	0.00 - 2.00	-	0.01	1.00	IDMT time multiplier for non-directional residual overcurrent

Table continues on next page

Name	Values (Range)	Unit	Step	Default	Description
OpUN>	Off On	-	-	Off	Operation of non-directional residual overvoltage
UN>	1.00 - 300.00	%UB	0.01	20.00	Set level for non-dir residual voltage, % of UBase
tUN	0.000 - 60.000	s	0.001	0.100	Time delay for non-directional residual overvoltage
INRel>	0.25 - 200.00	%IB	0.01	1.00	Residual release current for all directional modes, in % of IBase
UNRel>	1.00 - 300.00	%UB	0.01	3.00	Residual release volt for all dir modes, % of UBase

Table 52: SDEPSDE Non group settings (basic)

Name	Values (Range)	Unit	Step	Default	Description
GlobalBaseSel	1 - 6	-	1	1	Selection of one of the Global Base Value groups

6.5.6 Monitored data

Table 53: SDEPSDE Monitored data

Name	Type	Values (Range)	Unit	Description
INCOSPHI	REAL	-	A	Mag of residual current along polarizing qty $3I_0\cos(\text{Fi-RCA})$
IN	REAL	-	A	Measured magnitude of the residual current $3I_0$
UN	REAL	-	kV	Measured magnitude of the residual voltage $3U_0$
SN	REAL	-	MVA	Measured magnitude of residual power $3I_03U_0\cos(\text{Fi-RCA})$
ANG FI-RCA	REAL	-	deg	Angle between $3U_0$ and $3I_0$ minus RCA (Fi-RCA)

6.5.7 Operation principle

6.5.7.1 Function inputs

The function is using phasors of the residual current and voltage. Group signals I3P and U3P containing phasors of residual current and voltage is taken from pre-processor blocks.

The sensitive directional earth fault protection has the following sub-functions included:

6.5.7.2 Directional residual current protection measuring $3I_0 \cdot \cos \phi$

ϕ is defined as the angle between the residual current $3I_0$ and the reference voltage. $U_{ref} = -3U_0 e^{jRCADir}$, that is $-3U_0$ rotated by the set characteristic angle $RCADir$ ($\phi = \text{ang}(3I_0) - \text{ang}(U_{ref})$). $RCADir$ is normally set equal to 0 in a high impedance earthed network with a neutral point resistor as the active current component is appearing out on the faulted feeder only. $RCADir$ is

set equal to -90° in an isolated network as all currents are mainly capacitive. The function operates when $3I_0 \cdot \cos \phi$ gets larger than the set value.

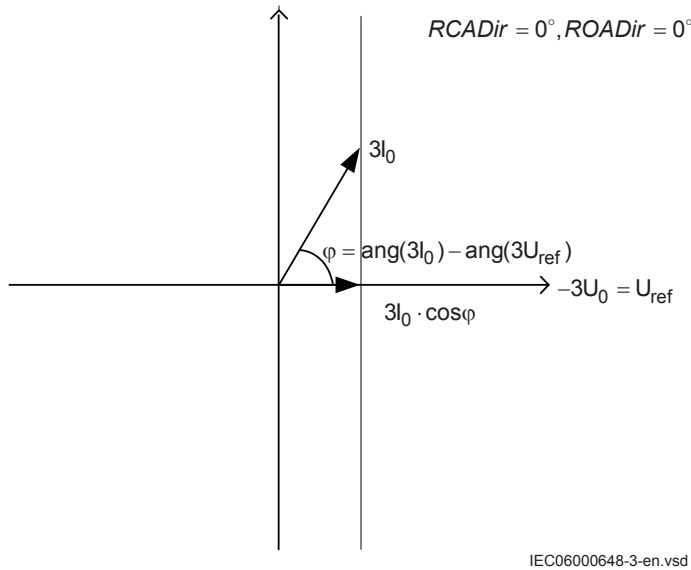

Figure 44: *RCADir* set to 0°

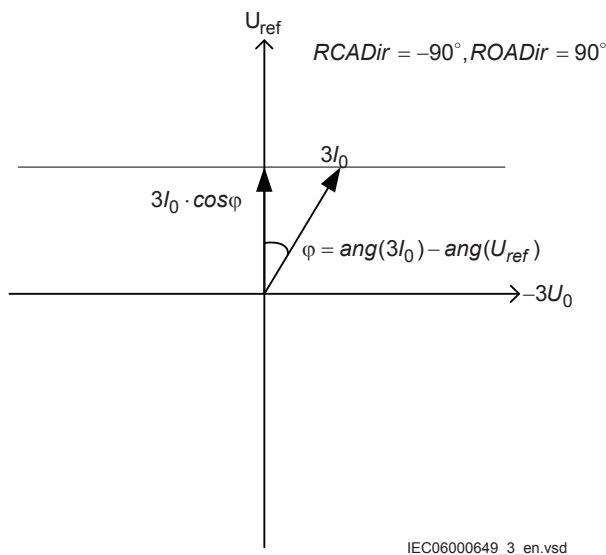
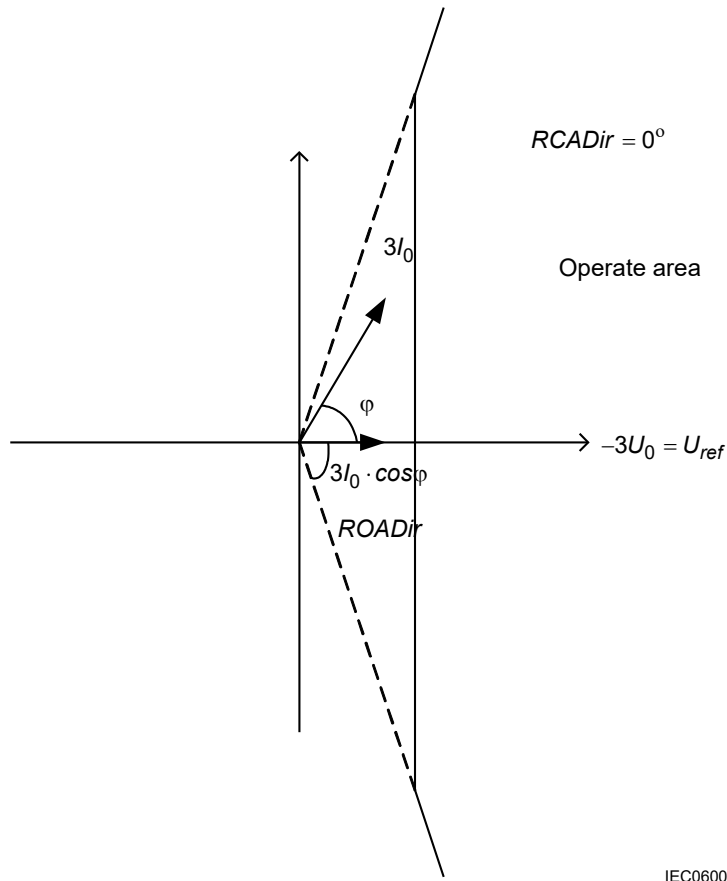

Figure 45: *RCADir* set to -90°

For trip, both the residual current $3I_0 \cdot \cos \phi$ and the release voltage $3U_0$, must be larger than the set levels: *INCosPhi*> and *UNRel*>.

When the function is activated binary output signals *START* and *STDIRIN* are activated. If the output signals are active after the set delay *tDef* the binary output signals *TRIP* and *TRDIRIN* are activated. The trip from this sub-function has definite time delay.

There is a possibility to increase the operate level for currents where the angle ϕ is larger than a set value as shown in figure 46. This is equivalent to blocking of the function if $\phi > ROADir$. This option is used to handle angle error for the instrument transformers.



IEC06000650_2_en.vsd

Figure 46: Characteristic with $ROADir$ restriction

The function indicates forward/reverse direction to the fault. Reverse direction is defined as $3I_0 \cdot \cos(\varphi + 180^\circ) \geq$ the set value.

It is also possible to tilt the characteristic to compensate for current transformer angle error with a setting $RCAComp$ as shown in the figure [47](#):

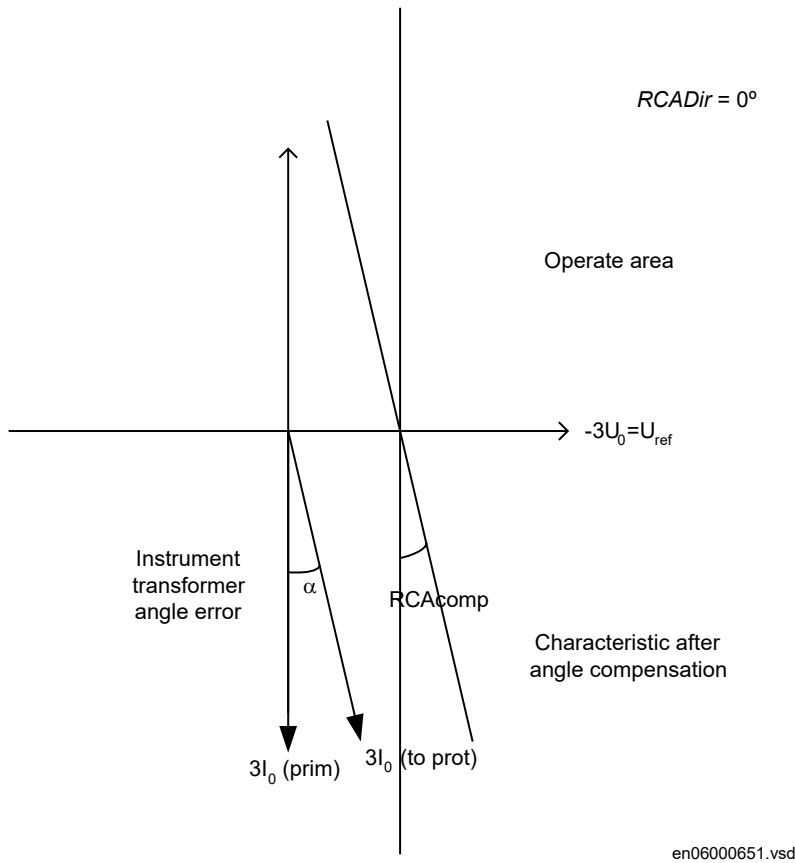

Figure 47: Explanation of RCAComp

6.5.7.3 Directional residual power protection measuring $3I_0 \cdot 3U_0 \cdot \cos \phi$

ϕ is defined as the angle between the residual current $3I_0$ and the reference voltage compensated with the set characteristic angle $RCADir$ ($\phi = \text{ang}(3I_0) - \text{ang}(U_{ref})$). $U_{ref} = -3U_0 e^{jRCADir}$. The function operates when $3I_0 \cdot 3U_0 \cdot \cos \phi$ gets larger than the set value.

For trip, both the residual power $3I_0 \cdot 3U_0 \cdot \cos \phi$, the residual current $3I_0$ and the release voltage $3U_0$, shall be larger than the set levels ($SN >$, $INRel >$ and $UNRel >$).

When the function is activated binary output signals START and STDIRIN are activated. If the output signals are active after the set delay $tDef$ or after the inverse time delay (setting kSM) the binary output signals TRIP and TRDIRIN are activated.

The function shall indicate forward/reverse direction to the fault. Reverse direction is defined as $3I_0 \cdot 3U_0 \cdot \cos(\phi + 180^\circ) \geq$ the set value.

This sub-function has the possibility of choice between definite time delay and inverse time delay.

The inverse time delay is defined as:

$$t_{inv} = \frac{kSN \cdot (3I_0 \cdot 3U_0 \cdot \cos \phi(\text{reference}))}{3I_0 \cdot 3U_0 \cdot \cos \phi(\text{measured})}$$

(Equation 15)

6.5.7.4 Directional residual current protection measuring $3I_0$ and ϕ

The function will operate if the residual current is larger than the set value and the angle $\phi = \text{ang}(3I_0) - \text{ang}(U_{\text{ref}} = -3U_0)$ is within the sector $RCADir \pm ROADir$

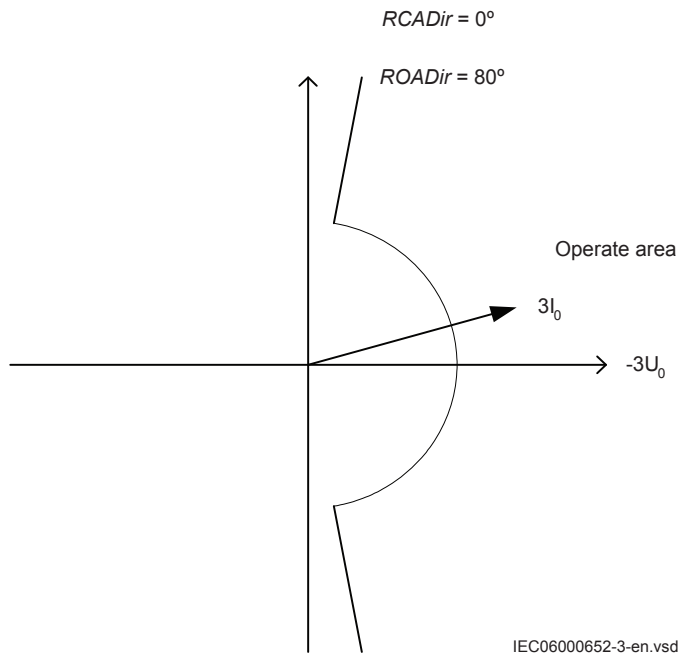

Figure 48: Example of characteristic

For trip, the residual current $3I_0$ shall be larger than the set level $INDir >$, the release voltage $3U_0$ shall be larger than the set level $UNREL >$ and the angle ϕ shall be in the set sector $ROADir$ and $RCADir$.

When the function is activated binary output signals START and STDIRIN are activated. If the output signals are active after the set delay $tDef$ the binary output signals TRIP and TRDIRIN are activated.

The function indicates forward/reverse direction to the fault. Reverse direction is defined as ϕ is within the angle sector: $RCADir + 180^\circ \pm ROADir$

This sub-function has definite time delay.

6.5.7.5 Directional functions

For all the directional functions there are directional start signals STFW: fault in the forward direction, and STRV: start in the reverse direction. Even if the directional function is set to operate for faults in the forward direction a fault in the reverse direction will give the start signal STRV. Also if the directional function is set to operate for faults in the reverse direction a fault in the forward direction will give the start signal STFW.

6.5.7.6 Non-directional earth fault current protection

This function will measure the residual current without checking the phase angle. The function will be used to detect cross-country faults. This function can serve as alternative or back-up to distance protection with phase preference logic.

The non-directional function is using the calculated residual current, derived as sum of the phase currents. This will give a better ability to detect cross-country faults with high residual

current, also when dedicated core balance CT for the sensitive earth fault protection will saturate.

This sub-function has the possibility of choice between definite time delay and inverse time delay. The inverse time delay shall be according to IEC 60255-3.

For trip, the residual current $3I_0$ shall be larger than the set level (IN_{NonDir}).

When the function is activated binary output signal STNDIN is activated. If the output signal is active after the set delay tIN_{NonDir} or after the inverse time delay the binary output signals TRIP and TRNDIN are activated.

6.5.7.7 Residual overvoltage release and protection

The directional function shall be released when the residual voltage gets higher than a set level.

There shall also be a separate trip, with its own definite time delay, from this level set voltage level.

For trip, the residual voltage $3U_0$ shall be larger than the set level (UN).

Trip from this function can be blocked from the binary input BLKUN.

When the function is activated binary output signal STUN is activated. If the output signals are active after the set delay tUN_{NonDir} TRIP and TRUN are activated. A simplified logical diagram of the total function is shown in figure [49](#).

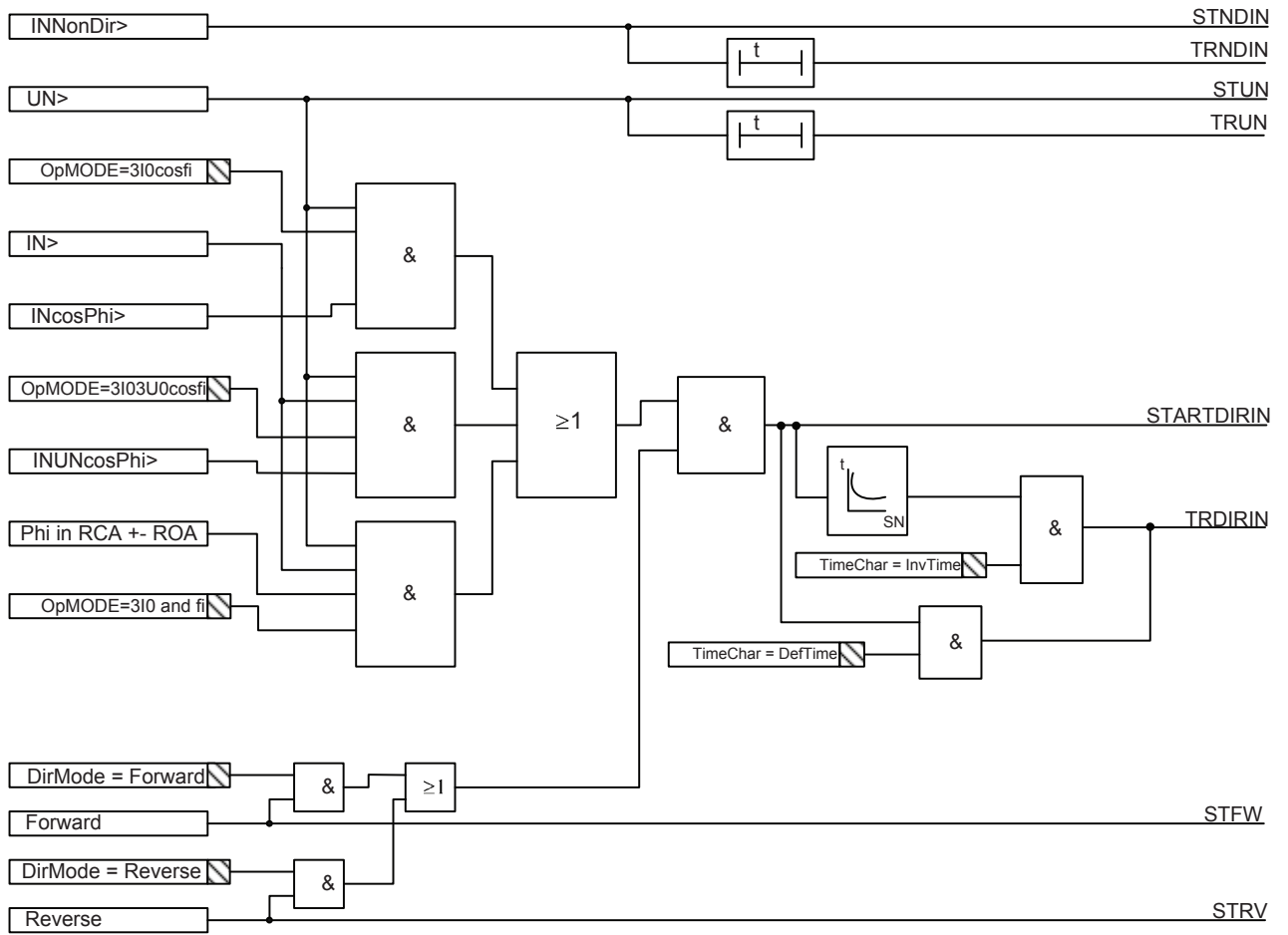

IEC09000147-2-en.vsd

Figure 49: Simplified logical diagram of the sensitive earth-fault current protection

6.5.8 Technical data

Table 54: SDEPSDE technical data

Function	Range or value	Accuracy
Operate level for $3I_0 \cdot \cos\varphi$ directional residual overcurrent	(0.25-200.00)% of <i>I</i> Base	$\pm 1.0\%$ of I_r at $I \leq I_r$ $\pm 1.0\%$ of I at $I > I_r$ At low setting: (0.25-1.00)% of I_r ; $\pm 0.05\%$ of I_r (1.00-5.00)% of I_r ; $\pm 0.1\%$ of I_r
Operate level for $3I_0 \cdot 3U_0 \cdot \cos\varphi$ directional residual power	(0.25-200.00)% of <i>S</i> Base	$\pm 2.0\%$ of S_r at $S \leq S_r$ $\pm 2.0\%$ of S at $S > S_r$ At low setting: (0.25-5.00)% of <i>S</i> Base $\pm 10\%$ of set value
Operate level for $3I_0$ and φ residual overcurrent	(0.25-200.00)% of <i>I</i> Base	$\pm 1.0\%$ of I_r at $I \leq I_r$ $\pm 1.0\%$ of I at $I > I_r$ At low setting: (0.25-1.00)% of I_r ; $\pm 0.05\%$ of I_r (1.00-5.00)% of I_r ; $\pm 0.1\%$ of I_r
Operate level for non-directional overcurrent	(1.00-400.00)% of <i>I</i> Base	$\pm 1.0\%$ of I_r at $I \leq I_r$ $\pm 1.0\%$ of I at $I > I_r$ At low setting $< 5\%$ of I_r : $\pm 0.1\%$ of I_r
Operate level for non-directional residual overvoltage	(1.00-200.00)% of <i>U</i> Base	$\pm 0.5\%$ of U_r at $U \leq U_r$ $\pm 0.5\%$ of U at $U > U_r$
Residual release current for all directional modes	(0.25-200.00)% of <i>I</i> Base	$\pm 1.0\%$ of I_r at $I \leq I_r$ $\pm 1.0\%$ of I at $I > I_r$ At low setting: (0.25-1.00)% of I_r ; $\pm 0.05\%$ of I_r (1.00-5.00)% of I_r ; $\pm 0.1\%$ of I_r
Residual release voltage for all directional modes	(1.00 - 300.00)% of <i>U</i> Base	$\pm 0.5\%$ of U_r at $U \leq U_r$ $\pm 0.5\%$ of U at $U > U_r$
Reset ratio	$> 95\%$	-
Timers	(0.000-60.000) s	$\pm 0.5\% \pm 25$ ms
Inverse characteristics, see table 573, table 574 and table 575	15 curve types	ANSI/IEEE C37.112 IEC 60255-151 $\pm 3.0\%$ or ± 90 ms $0.10 \leq k \leq 3.00$ $1.5 \times I_{set} \leq I \leq 20 \times I_{set}$
Relay characteristic angle RCA	(-179 to 180) degrees	± 2.0 degrees
Relay open angle ROA	(0-90) degrees	± 2.0 degrees
Operate time, non-directional residual over current	60 ms typically at 0 to $2 \times I_{set}$	60 ms typically at 0 to $2 \times I_{set}$
Reset time, non-directional residual over current	65 ms typically at 2 to $0 \times I_{set}$	65 ms typically at 2 to $0 \times I_{set}$
Table continues on next page		

Function	Range or value	Accuracy
Operate time, non-directional residual overvoltage	45 ms typically at 0.8 to 1.5 x U _{set}	45 ms typically at 0.8 to 1.5 x U _{set}
Reset time, non-directional residual overvoltage	85 ms typically at 1.2 to 0.8 x U _{set}	85 ms typically at 1.2 to 0.8 x U _{set}
Operate time, directional residual over current	140 ms typically at 0.5 to 2 x I _{set}	-
Reset time, directional residual over current	85 ms typically at 2 to 0.5 x I _{set}	-
Critical impulse time non-directional residual over current	35 ms typically at 0 to 2 x I _{set}	-
Impulse margin time non-directional residual over current	25 ms typically	-

6.6 Thermal overload protection, one time constant Celsius/Fahrenheit LCPTTR/LFPTTR

6.6.1 Identification

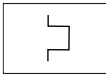
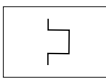
Function description	IEC 61850 identification	IEC 60617 identification	ANSI/IEEE C37.2 device number
Thermal overload protection, one time constant, Celsius	LCPTTR		26
Thermal overload protection, one time constant, Fahrenheit	LFPTTR		26

6.6.2 Functionality

The increasing utilizing of the power system closer to the thermal limits has generated a need of a thermal overload protection also for power lines.

A thermal overload will often not be detected by other protection functions and the introduction of the thermal overload protection can allow the protected circuit to operate closer to the thermal limits.

The three-phase current measuring protection has an I²t characteristic with settable time constant and a thermal memory. The temperature is displayed in either in Celsius or in Fahrenheit depending on whether the function used is Thermal overload protection one time constant, Celsius LCPTTR or Fahrenheit LFPTTR.

An alarm level gives early warning to allow operators to take action well before the line is tripped.

Estimated time to trip before operation, and estimated time to reclose after operation are presented.

6.6.3 Function block

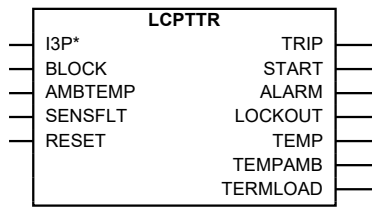

IEC08000038-2-en.vsd

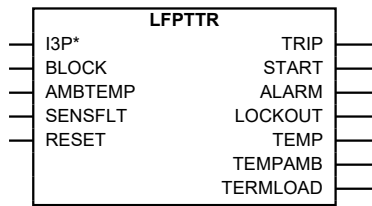

IEC11000246-1-en.vsd

Figure 50: LCPTR/LFPTTR function block

6.6.4 Signals

Table 55: LCPTR Input signals

Name	Type	Default	Description
I3P	GROUP SIGNAL	-	Three phase group signal for current inputs
BLOCK	BOOLEAN	0	Block of function
AMBTEMP	REAL	0	Ambient temperature from external temperature sensor
SENSFLT	BOOLEAN	0	Validity status of ambient temperature sensor
RESET	BOOLEAN	0	Reset of internal thermal load counter

Table 56: LFPTTR Input signals

Name	Type	Default	Description
I3P	GROUP SIGNAL	-	Three phase group signal for current inputs
BLOCK	BOOLEAN	0	Block of function
AMBTEMP	REAL	0	Ambient temperature from external temperature sensor
SENSFLT	BOOLEAN	0	Validity status of ambient temperature sensor
RESET	BOOLEAN	0	Reset of internal thermal load counter

Table 57: LCPTTR Output signals

Name	Type	Description
TRIP	BOOLEAN	General trip signal
START	BOOLEAN	General start signal
ALARM	BOOLEAN	Alarm signal
LOCKOUT	BOOLEAN	Lockout signal
TEMP	REAL	Calculated temperature of the device
TEMPAMB	REAL	Ambient temperature used in the calculations
TERMLOAD	REAL	Temperature relative to operate temperature

Table 58: LFPTTR Output signals

Name	Type	Description
TRIP	BOOLEAN	General trip signal
START	BOOLEAN	General start signal
ALARM	BOOLEAN	Alarm signal
LOCKOUT	BOOLEAN	Lockout signal
TEMP	REAL	Calculated temperature of the device
TEMPAMB	REAL	Ambient temperature used in the calculations
TERMLOAD	REAL	Temperature relative to operate temperature

6.6.5 Settings

Table 59: LCPTTR Group settings (basic)

Name	Values (Range)	Unit	Step	Default	Description
Operation	Off On	-	-	Off	Operation Off / On
TRef	0 - 300	Deg C	1	90	End temperature rise above ambient of the line when loaded with IRef
IRef	0 - 400	%IB	1	100	Load current in % of IBase leading to TRef temperature
Tau	1 - 1000	Min	1	45	Time constant of the line
AlarmTemp	0 - 200	Deg C	1	80	Temperature level for start (alarm)
TripTemp	0 - 300	Deg C	1	90	Temperature level for trip
ReclTemp	0 - 300	Deg C	1	75	Temperature for reset of lockout after trip
AmbiSens	Off On	-	-	Off	External temperature sensor available
DefaultAmbTemp	-50 - 100	Deg C	1	20	Ambient temperature used when AmbiSens is set to Off
DefaultTemp	-50 - 300	Deg C	1	50	Temperature raise above ambient temperature at startup

Table 60: LCPTTR Non group settings (basic)

Name	Values (Range)	Unit	Step	Default	Description
GlobalBaseSel	1 - 6	-	1	1	Selection of one of the Global Base Value groups

Table 61: LFPTTR Group settings (basic)

Name	Values (Range)	Unit	Step	Default	Description
Operation	Off On	-	-	Off	Operation Off / On
TRef	0 - 600	Deg F	1	160	End temperature rise above ambient of the line when loaded with IRef
IRef	0 - 400	%IB	1	100	Load current in % of IBase leading to TRef temperature
Tau	1 - 1000	Min	1	45	Time constant of the line
AlarmTemp	0 - 400	Deg F	1	175	Temperature level for start (alarm)
TripTemp	0 - 600	Deg F	1	195	Temperature level for trip
ReclTemp	0 - 600	Deg F	1	170	Temperature for reset of lockout after trip
AmbiSens	Off On	-	-	Off	External temperature sensor available
DefaultAmbTemp	-50 - 250	Deg F	1	60	Ambient temperature used when AmbiSens is set to Off
DefaultTemp	-50 - 600	Deg F	1	100	Temperature raise above ambient temperature at startup

Table 62: LFPTTR Non group settings (basic)

Name	Values (Range)	Unit	Step	Default	Description
GlobalBaseSel	1 - 6	-	1	1	Selection of one of the Global Base Value groups

6.6.6 Monitored data

Table 63: LCPTTR Monitored data

Name	Type	Values (Range)	Unit	Description
TTRIP	INTEGER	-	-	Estimated time to trip (in min)
TENRECL	INTEGER	-	-	Estimated time to reset of lockout (in min)
TEMP	REAL	-	deg	Calculated temperature of the device
TEMPAMB	REAL	-	deg	Ambient temperature used in the calculations

Table 64: LFPTTR Monitored data

Name	Type	Values (Range)	Unit	Description
TTRIP	INTEGER	-	-	Estimated time to trip (in min)
TENRECL	INTEGER	-	-	Estimated time to reset of lockout (in min)
TEMP	REAL	-	Temperature Fahrenheit	Calculated temperature of the device
TEMPAMB	REAL	-	Temperature Fahrenheit	Ambient temperature used in the calculations

6.6.7 Operation principle

The sampled analog phase currents are pre-processed and for each phase current the RMS value is derived. These phase current values are fed to the thermal overload protection, one time constant LCPTTR/LFPTTR function. The temperature is displayed either in Celsius or Fahrenheit, depending on whether LCPTTR/LFPTTR function is selected.

From the largest of the three-phase currents a final temperature is calculated according to the expression:

$$\Theta_{final} = \left(\frac{I}{I_{ref}} \right)^2 \cdot T_{ref}$$

(Equation 16)

where:

I is the largest phase current,

I_{ref} is a given reference current and

T_{ref} is steady state temperature rise corresponding to I_{ref}

If this temperature is larger than the set operate temperature level, *TripTemp*, a START output signal is activated.

The actual temperature at the actual execution cycle is calculated as:

$$\Theta_n = \Theta_{n-1} + \left(\Theta_{final} - \Theta_{n-1} \right) \cdot \left(1 - e^{-\frac{\Delta t}{\tau}} \right)$$

(Equation 17)

where:

Θ_n is the calculated present temperature,

Θ_{n-1} is the calculated temperature at the previous time step,

Θ_{final} is the calculated final temperature with the actual current,

Δt is the time step between calculation of the actual temperature and

τ is the set thermal time constant for the protected device (line or cable)

The calculated component temperature is available as a real figure signal, TEMP.

When the component temperature reaches the set alarm level *AlarmTemp* the output signal ALARM is set. When the component temperature reaches the set trip level *TripTemp* the output signal TRIP is set.

There is also a calculation of the present time to operate with the present current. This calculation is only performed if the final temperature is calculated to be above the operation temperature:

$$t_{operate} = -\tau \cdot \ln \left(\frac{\Theta_{final} - \Theta_{operate}}{\Theta_{final} - \Theta_n} \right)$$

(Equation 18)

The calculated time to trip is available as a real figure signal, TTRIP.

After a trip, caused by the thermal overload protection, there can be a lockout to reconnect the tripped circuit. The output lockout signal LOCKOUT is activated when the device temperature is above the set lockout release temperature setting *RecTemp*.

The time to lockout release is calculated that is, a calculation of the cooling time to a set value. The thermal content of the function can be reset with input RESET.

$$t_{lockout_release} = -\tau \cdot \ln \left(\frac{\Theta_{final} - \Theta_{lockout_release}}{\Theta_{final} - \Theta_n} \right)$$

(Equation 19)

The calculated time to reset of lockout is available as a real figure signal, TENRECL.

The protection has a reset input: RESET. By activating this input the calculated temperature is reset to its default initial value. This is useful during testing when secondary injected current has given a calculated “false” temperature level.

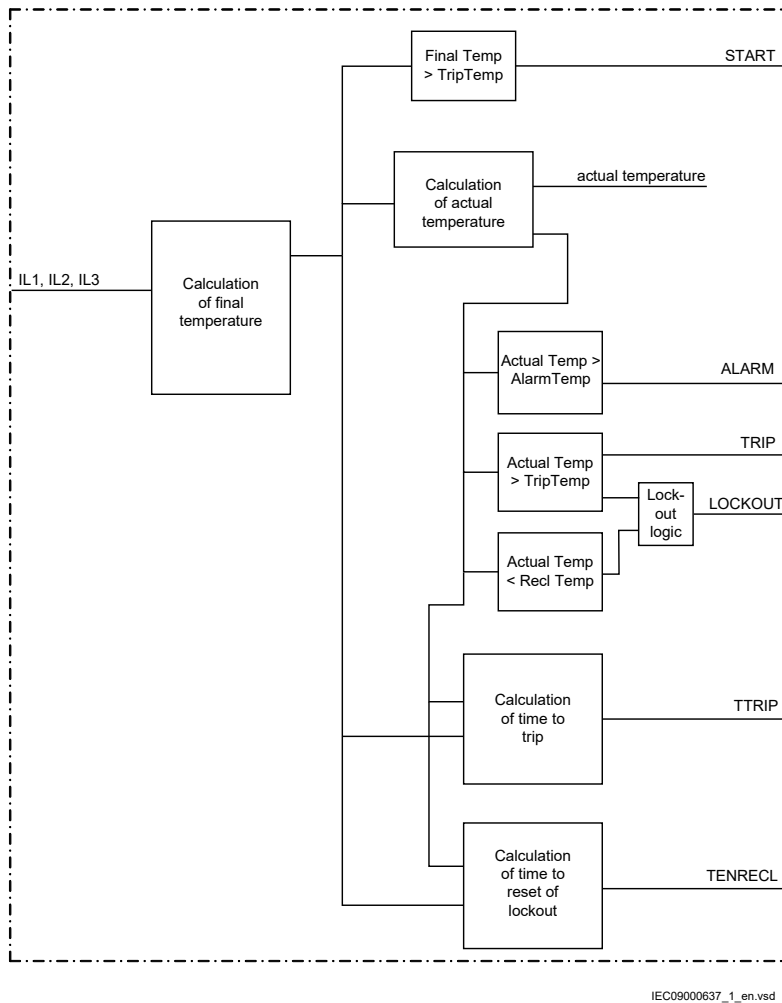

Figure 51: Functional overview of LCPTTR/LFPTTR

6.6.8 Technical data

Table 65: LCPTTR/LFPTTR technical data

Function	Range or value	Accuracy
Reference current	(0-400)% of IBase	± 1.0% of I _r
Reference temperature	(0-300)°C, (0 - 600)°F	± 2.0°C, ±2.0°F
Operate time: $t = \tau \cdot \ln \left(\frac{I^2 - I_p^2}{I^2 - I_{ref}^2} \right)$ (Equation 20) I = actual measured current I _p = load current before overload occurs I _{ref} = reference load current	Time constant τ = (0–1000) minutes	IEC 60255-8, ±5% + 200 ms
Table continues on next page		

Function	Range or value	Accuracy
Alarm temperature	(0-200)°C, (0-400)°F	± 2.0°C ± 2.0°F
Trip temperature	(0-300)°C, (0-600)°F	± 2.0°C ± 2.0°F
Reset level temperature	(0-300)°C, (0-600)°F	± 2.0°C ± 2.0°F

6.7 Breaker failure protection 3-phase activation and output CCRBRF

6.7.1 Identification

Function description	IEC 61850 identification	IEC 60617 identification	ANSI/IEEE C37.2 device number
Breaker failure protection, 3-phase activation and output	CCRBRF	<div style="border: 1px solid black; padding: 5px; width: fit-content; margin: 0 auto;">3I>BF</div>	50BF

6.7.2 Functionality

CCRBRF can be current based, contact based, or an adaptive combination of these two conditions.

Breaker failure protection, 3-phase activation and output (CCRBRF) ensures fast back-up tripping of surrounding breakers in case the own breaker fails to open. CCRBRF can be current based, contact based, or an adaptive combination of these two conditions.

Current check with extremely short reset time is used as check criterion to achieve high security against inadvertent operation.

Contact check criteria can be used where the fault current through the breaker is small.

Breaker failure protection, 3-phase activation and output (CCRBRF) current criteria can be fulfilled by one or two phase currents the residual current, or one phase current plus residual current. When those currents exceed the user defined settings, the function is triggered. These conditions increase the security of the back-up trip command.

CCRBRF function can be programmed to give a three-phase re-trip of the own breaker to avoid inadvertent tripping of surrounding breakers.

6.7.3 Function block

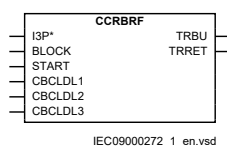

Figure 52: CCRBRF function block

6.7.4 Signals

Table 66: CCRBRF Input signals

Name	Type	Default	Description
I3P	GROUP SIGNAL	-	Three phase group signal for current inputs
BLOCK	BOOLEAN	0	Block of function
START	BOOLEAN	0	Three phase start of breaker failure protection function
CBCLDL1	BOOLEAN	1	Circuit breaker closed in phase L1
CBCLDL2	BOOLEAN	1	Circuit breaker closed in phase L2
CBCLDL3	BOOLEAN	1	Circuit breaker closed in phase L3

Table 67: CCRBRF Output signals

Name	Type	Description
TRBU	BOOLEAN	Back-up trip by breaker failure protection function
TRRET	BOOLEAN	Retrip by breaker failure protection function

6.7.5 Settings

Table 68: CCRBRF Group settings (basic)

Name	Values (Range)	Unit	Step	Default	Description
Operation	Off On	-	-	Off	Operation Off / On
FunctionMode	Current Contact Current&Contact	-	-	Current	Detection principle for back-up trip
BuTripMode	2 out of 4 1 out of 3 1 out of 4	-	-	1 out of 3	Back-up trip mode
RetripMode	Retrip Off CB Pos Check No CBPos Check	-	-	Retrip Off	Operation mode of re-trip logic
IP>	5 - 200	%IB	1	10	Operate phase current level in % of IBase
IN>	2 - 200	%IB	1	10	Operate residual current level in % of IBase
t1	0.000 - 60.000	s	0.001	0.000	Time delay of re-trip
t2	0.000 - 60.000	s	0.001	0.150	Time delay of back-up trip

Table 69: CCRBRF Group settings (advanced)

Name	Values (Range)	Unit	Step	Default	Description
I>BlkCont	5 - 200	%IB	1	20	Current for blocking of CB contact operation in % of IBase

Table 70: CCRBRF Non group settings (basic)

Name	Values (Range)	Unit	Step	Default	Description
GlobalBaseSel	1 - 6	-	1	1	Selection of one of the Global Base Value groups

6.7.6 Monitored data

Table 71: CCRBRF Monitored data

Name	Type	Values (Range)	Unit	Description
IL1	REAL	-	A	Measured current in phase L1
IL2	REAL	-	A	Measured current in phase L2
IL3	REAL	-	A	Measured current in phase L3
IN	REAL	-	A	Measured residual current

6.7.7 Operation principle

Breaker failure protection, 3-phase activation and output CCRBRF is initiated from protection trip command, either from protection functions within the IED or from external protection devices.

The start signal is general for all three phases. A re-trip attempt can be made after a set time delay. The re-trip function can be done with or without CB position check based on current and/or contact evaluation. With the current check the re-trip is only performed if the current through the circuit breaker is larger than the operate current level. With contact check the re-trip is only performed if breaker is indicated as closed.

The start signal can be an internal or external protection trip signal. This signal will start the back-up trip timer. If the opening of the breaker is successful this is detected by the function, by detection of either low current through RMS evaluation and a special adapted current algorithm or by open contact indication. The special algorithm enables a very fast detection of successful breaker opening, that is, fast resetting of the current measurement. If the current and/or contact detection has not detected breaker opening before the back-up timer has run its time a back-up trip is initiated.

Further the following possibilities are available:

- In the current detection it is possible to use three different options: *1 out of 3* where it is sufficient to detect failure to open (high current) in one pole, *1 out of 4* where it is sufficient to detect failure to open (high current) in one pole or high residual current and *2 out of 4* where at least two current (phase current and/or residual current) shall be high for breaker failure detection.
- The current detection level for the residual current can be set different from the setting of phase current detection.
- Back-up trip is always made with current or contact check. It is possible to have this option activated for small load currents only.

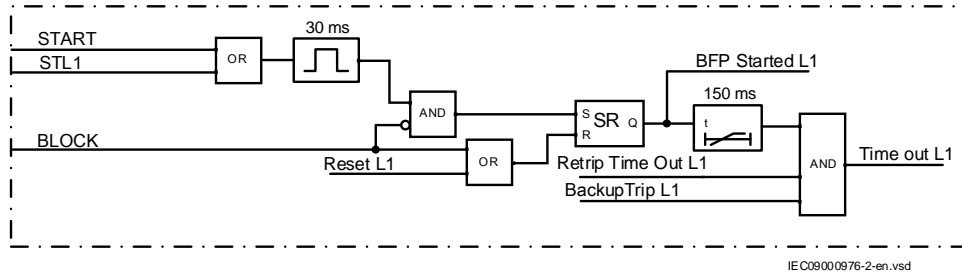

IEC09000976-2-en.vsd

Figure 53: Simplified logic scheme of the CCRBRF starting logic

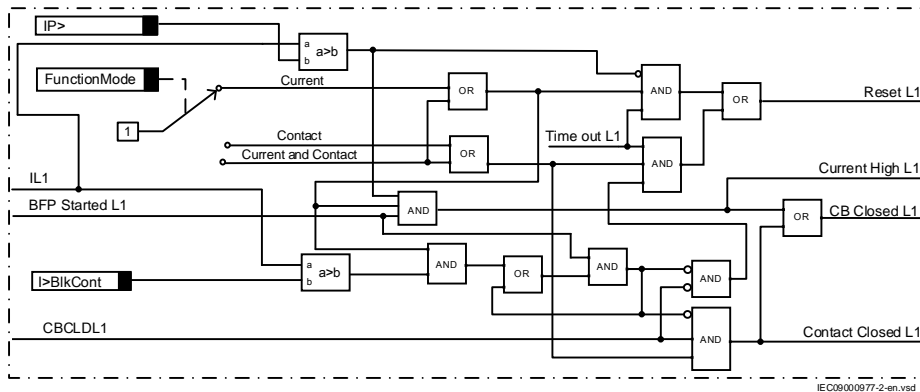

IEC09000977-2-en.vsd

Figure 54: Simplified logic scheme of the CCRBRF, CB position evaluation

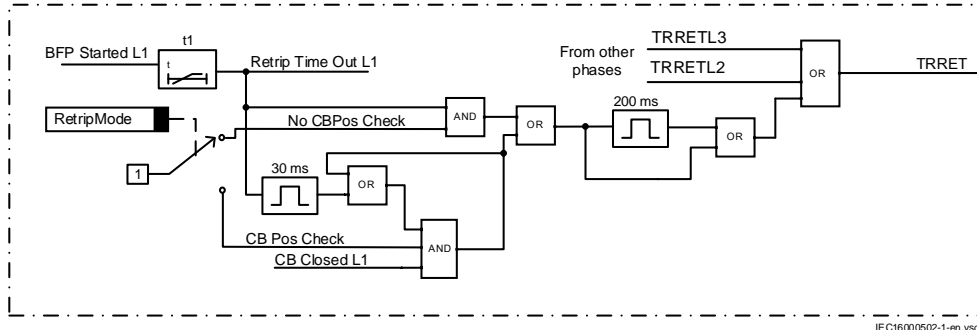

IEC16000502-1-en.vsd

Figure 55: Simplified logic scheme of the retrip logic function

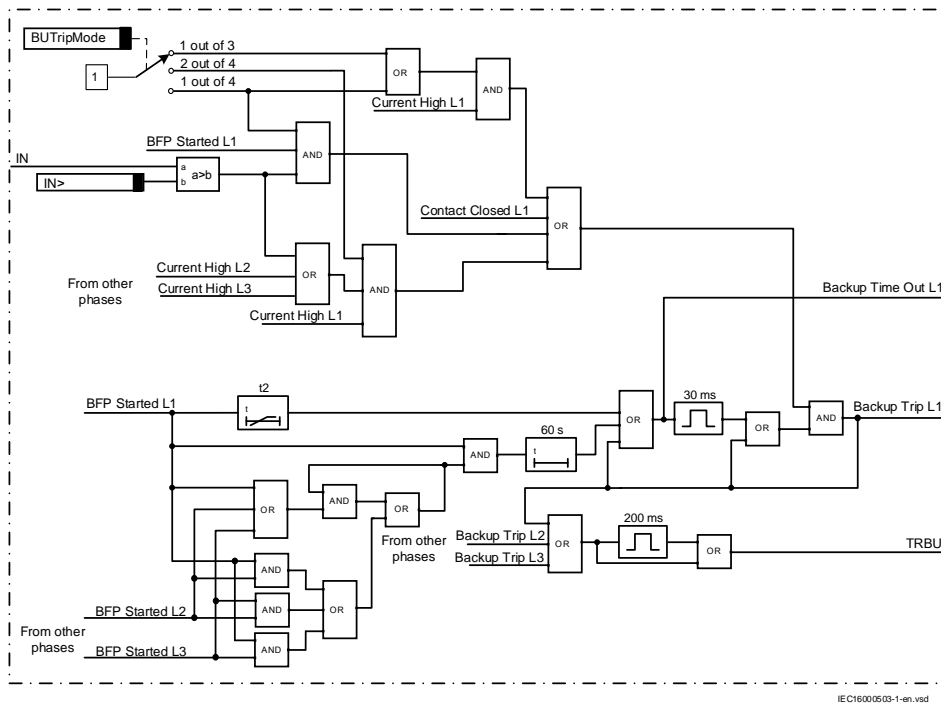

Figure 56: Simplified logic scheme of the back-up trip function

Internal logical signals Current High L1, Current High L2, and Current High L3 have logical value 1 when current in respective phase has magnitude larger than setting parameter I_P .

6.7.8 Technical data

Table 72: CCRBRF technical data

Function	Range or value	Accuracy
Operate phase current	(5-200)% of I_{Base}	$\pm 1.0\%$ of I_r at $I \leq I_r$ $\pm 1.0\%$ of I at $I > I_r$
Reset ratio, phase current	> 95%	-
Operate residual current	(2-200)% of I_{Base}	$\pm 1.0\%$ of I_r at $I \leq I_r$ $\pm 1.0\%$ of I at $I > I_r$
Reset ratio, residual current	> 95%	-
Phase current level for blocking of contact function	(5-200)% of I_{Base}	$\pm 1.0\%$ of I_r at $I \leq I_r$ $\pm 1.0\%$ of I at $I > I_r$
Reset ratio	> 95%	-
Timers	(0.000-60.000) s	$\pm 0.5\% \pm 10$ ms
Operate time for current detection	20 ms typically	-
Reset time for current detection	10 ms maximum	-

6.8 Stub protection STBPTOC

6.8.1 Identification

Function description	IEC 61850 identification	IEC 60617 identification	ANSI/IEEE C37.2 device number
Stub protection	STBPTOC		50STB

6.8.2 Functionality

When a power line is taken out of service for maintenance and the line disconnecter is opened the voltage transformers will mostly be outside on the disconnected part. The primary line distance protection will thus not be able to operate and must be blocked.

The stub protection STBPTOC covers the zone between the current transformers and the open disconnecter. The three-phase instantaneous overcurrent function is released from a normally open, NO (b) auxiliary contact on the line disconnecter.

6.8.3 Function block

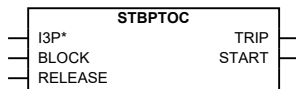

Figure 57: STBPTOC function block

6.8.4 Signals

Table 73: STBPTOC Input signals

Name	Type	Default	Description
I3P	GROUP SIGNAL	-	Three phase group signal for current inputs
BLOCK	BOOLEAN	0	Block of function
RELEASE	BOOLEAN	0	Release of stub protection

Table 74: STBPTOC Output signals

Name	Type	Description
TRIP	BOOLEAN	General trip signal
START	BOOLEAN	General start signal

6.8.5 Settings

Table 75: STBPTOC Group settings (basic)

Name	Values (Range)	Unit	Step	Default	Description
Operation	Off On	-	-	Off	Operation Off / On
I>	1 - 2500	%IB	1	200	Operate current level in % of IBase

Table 76: STBPTOC Non group settings (basic)

Name	Values (Range)	Unit	Step	Default	Description
GlobalBaseSel	1 - 6	-	1	1	Selection of one of the Global Base Value groups

6.8.6 Monitored data

Table 77: STBPTOC Monitored data

Name	Type	Values (Range)	Unit	Description
IL1	REAL	-	A	Current in phase L1
IL2	REAL	-	A	Current in phase L2
IL3	REAL	-	A	Current in phase L3

6.8.7 Operation principle

The sampled analog phase currents are pre-processed in a discrete Fourier filter (DFT) block. From the fundamental frequency components of each phase current the RMS value of each phase current is derived. These phase current values are fed to a comparator in the stub protection function STBPTOC. In a comparator the RMS values are compared to the set operating current value of the function I>.

If a phase current is larger than the set operating current the signal from the comparator for this phase is activated. If the fault current remains during the timer delay t , the TRIP output signal is activated. The function can be blocked by activation of the BLOCK input.

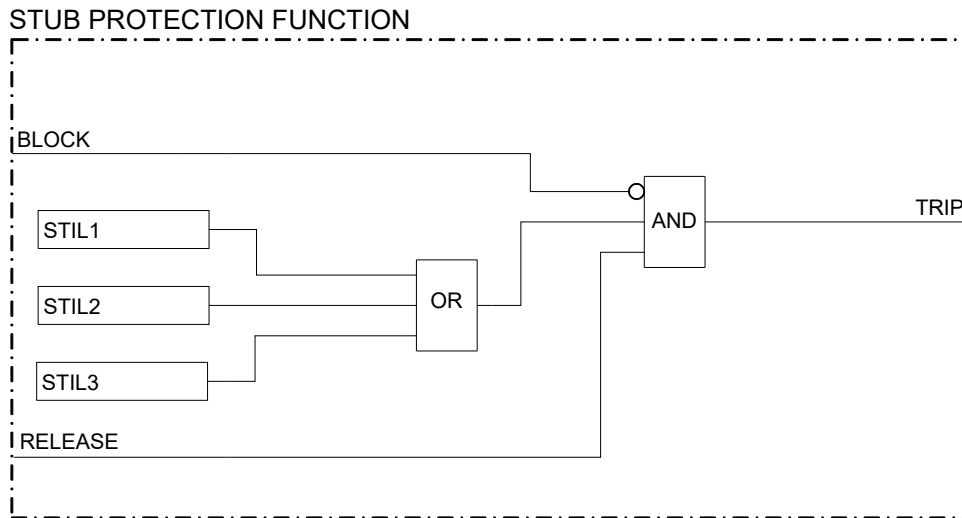

en05000731.vsd

Figure 58: Simplified logic diagram for Stub protection

6.8.8 Technical data

Table 78: STBPTOC technical data

Function	Range or value	Accuracy
Operating current	(1-2500)% of I_{Base}	$\pm 1.0\%$ of I_r at $I \leq I_r$ $\pm 1.0\%$ of I at $I > I_r$
Reset ratio	> 95%	-
Operate time	20 ms typically at 0 to $2 \times I_{set}$	-
Reset time	30 ms typically at 2 to $0 \times I_{set}$	-
Critical impulse time	10 ms typically at 0 to $2 \times I_{set}$	-
Impulse margin time	15 ms typically	-

6.9 Pole discordance protection CCRPLD

6.9.1 Identification

Function description	IEC 61850 identification	IEC 60617 identification	ANSI/IEEE C37.2 device number
Pole discordance protection	CCRPLD	<div style="border: 1px solid black; width: 40px; height: 40px; display: flex; align-items: center; justify-content: center; margin: 0 auto;"> <i>PD</i> </div>	52PD

6.9.2 Functionality

Circuit breakers and disconnectors can end up with the phases in different positions (close-open), due to electrical or mechanical failures. An open phase can cause negative and zero sequence currents which cause thermal stress on rotating machines and can cause unwanted operation of zero sequence or negative sequence current functions.

Normally the own breaker is tripped to correct such a situation. If the situation persists the surrounding breakers should be tripped to clear the unsymmetrical load situation.

The pole discordance function operates based on information from the circuit breaker logic with additional criteria from phase selective current unsymmetry.

6.9.3 Function block

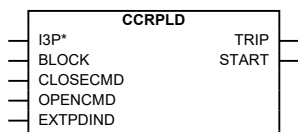

Figure 59: CCRPLD function block

6.9.4 Signals

Table 79: CCRPLD Input signals

Name	Type	Default	Description
I3P	GROUP SIGNAL	-	Three phase group signal for current inputs
BLOCK	BOOLEAN	0	Block of function
CLOSECMD	BOOLEAN	0	Close order to CB
OPENCMD	BOOLEAN	0	Open order to CB
EXTPDIND	BOOLEAN	0	Pole discordance signal from CB logic

Table 80: CCRPLD Output signals

Name	Type	Description
TRIP	BOOLEAN	Trip signal to CB
START	BOOLEAN	Trip condition TRUE, waiting for time delay

6.9.5 Settings

Table 81: CCRPLD Group settings (basic)

Name	Values (Range)	Unit	Step	Default	Description
Operation	Off On	-	-	Off	Operation Off / On
tTrip	0.000 - 60.000	s	0.001	0.300	Time delay between trip condition and trip signal
ContSel	Off PD signal from CB	-	-	Off	Contact function selection
CurrSel	Off CB oper monitor Continuous monitor	-	-	Off	Current function selection
CurrUnsymLevel	0 - 100	%	1	80	Unsym magn of lowest phase current compared to the highest.
CurrRelLevel	0 - 100	%IB	1	10	Current magnitude for release of the function in % of IBase

Table 82: CCRPLD Non group settings (basic)

Name	Values (Range)	Unit	Step	Default	Description
GlobalBaseSel	1 - 6	-	1	1	Selection of one of the Global Base Value groups

6.9.6 Monitored data

Table 83: CCRPLD Monitored data

Name	Type	Values (Range)	Unit	Description
IMin	REAL	-	A	Lowest phase current
IMax	REAL	-	A	Highest phase current

6.9.7 Operation principle

The detection of pole discordance can be made in two different ways. If the contact based function is used an external logic can be made by connecting the auxiliary contacts of the circuit breaker so that a pole discordance is indicated, see figure [60](#).

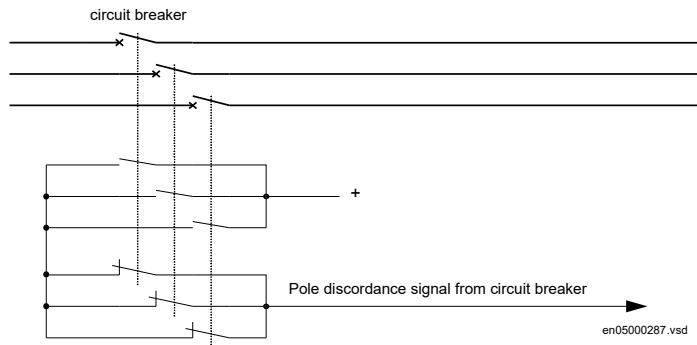

Figure 60: Pole discordance external detection logic

This binary signal is connected to a binary input of the IED. The appearance of this signal will start a timer that will give a trip signal after the set time delay.

Pole discordance can also be detected by means of phase selective current measurement. The sampled analog phase currents are pre-processed in a discrete Fourier filter (DFT) block. From the fundamental frequency components of each phase current the RMS value of each phase current is derived. The smallest and the largest phase current are derived. If the smallest phase current is lower than the setting *CurrUnsymLevel* times the largest phase current the settable trip timer (*tTrip*) is started. The *tTrip* timer gives a trip signal after the set delay. The TRIP signal is a pulse 150 ms long. The current based pole discordance function can be set to be active either continuously or only directly in connection to breaker open or close command.

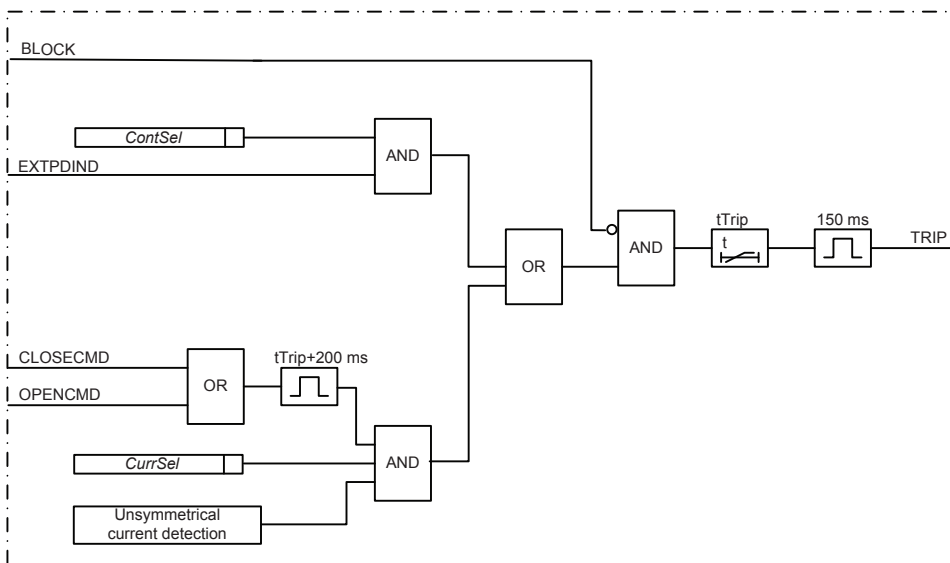

Figure 61: Simplified block diagram of pole discordance function - contact and current based

The pole discrepancy protection is blocked if the input signal BLOCK is high.

The BLOCK signal is a general purpose blocking signal of the pole discordance protection. It can be connected to a binary input in the IED in order to receive a block command from external devices or can be software connected to other internal functions in the IED itself in order to receive a block command from internal functions. Through OR gate it can be connected to both binary inputs and internal function outputs.

If the pole discordance protection is enabled, then two different criteria can generate a trip signal TRIP:

- Pole discordance signaling from the circuit breaker.
- Unsymmetrical current detection.

6.9.7.1 Pole discordance signaling from circuit breaker

If one or two poles of the circuit breaker have failed to open or to close (pole discordance status), then the function input EXTPDIND is activated from the pole discordance signal in figure 60. After a settable time t_{Trip} , a 150 ms trip pulse command TRIP is generated by the pole discordance function.

6.9.7.2 Unsymmetrical current detection

Unsymmetrical current indicated if:

- any phase current is lower than $CurrUnsymLevel$ of the highest current in the three phases.
- the highest phase current is greater than $CurrRelLevel$ of I_{Base} .

If these conditions are true, an unsymmetrical condition is detected. This detection is enabled to generate a trip after a set time delay t_{Trip} if the detection occurs in the next 200 ms after the circuit breaker has received a command to open trip or close and if the unbalance persists. The 200 ms limitation is for avoiding unwanted operation during unsymmetrical load conditions.

The pole discordance protection is informed that a trip or close command has been given to the circuit breaker through the inputs CLOSECMD (for closing command information) and OPENCMD (for opening command information). These inputs can be connected to terminal binary inputs if the information are generated from the field (that is from auxiliary contacts of the close and open push buttons) or may be software connected to the outputs of other integrated functions (that is close command from a control function or a general trip from integrated protections).

6.9.8 Technical data

Table 84: CCRPLD technical data

Function	Range or value	Accuracy
Operate value, current asymmetry level	(0-100) %	$\pm 1.0\%$ of I_r
Reset ratio	>95%	-
Time delay	(0.000-60.000) s	$\pm 0.5\% \pm 25$ ms

6.10 Broken conductor check BRCPTOC

6.10.1 Identification

Function description	IEC 61850 identification	IEC 60617 identification	ANSI/IEEE C37.2 device number
Broken conductor check	BRCPTOC	-	46

6.10.2 Functionality

Conventional protection functions can not detect the broken conductor condition. Broken conductor check BRCPTOC function, consisting of continuous phase selective current unsymmetrical check on the line where the IED is connected will give alarm or trip at detecting broken conductors.

6.10.3 Function block



IEC09000277_1_en.vsd

Figure 62: BRCPTOC function block

6.10.4 Signals

Table 85: BRCPTOC Input signals

Name	Type	Default	Description
I3P	GROUP SIGNAL	-	Three phase group signal for current inputs
BLOCK	BOOLEAN	0	Block of function

Table 86: BRCPTOC Output signals

Name	Type	Description
TRIP	BOOLEAN	Operate signal of the protection logic
START	BOOLEAN	Start signal of the protection logic

6.10.5 Settings

Table 87: BRCPTOC Group settings (basic)

Name	Values (Range)	Unit	Step	Default	Description
Operation	Off On	-	-	Off	Operation Off / On
Iub>	50 - 90	%IM	1	50	Unbalance current operation value in percent of max current
IP>	5 - 100	%IB	1	20	Minimum phase current for operation of Iub> in % of Ibase
tOper	0.000 - 60.000	s	0.001	5.000	Operate time delay

Table 88: BRCPTOC Non group settings (basic)

Name	Values (Range)	Unit	Step	Default	Description
GlobalBaseSel	1 - 6	-	1	1	Selection of one of the Global Base Value groups

6.10.6 Monitored data

Table 89: BRCPTOC Monitored data

Name	Type	Values (Range)	Unit	Description
IUNBAL	REAL	-	-	Measured unbalance of phase currents

6.10.7 Operation principle

Broken conductor check (BRCPTOC) detects a broken conductor condition by detecting the asymmetry between currents in the three phases. The current-measuring elements continuously measure the three-phase currents.

The current asymmetry signal output START is set on if:

- The difference in currents between the phase with the lowest current and the phase with the highest current is greater than set percentage $I_{ub>}$ of the highest phase current
- The highest phase current is greater than the minimum setting value $IP>$.
- The lowest phase current is below 50% of the minimum setting value $IP>$

The third condition is included to avoid problems in systems involving parallel lines. If a conductor breaks in one phase on one line, the parallel line will experience an increase in current in the same phase. This might result in the first two conditions being satisfied. If the unsymmetrical detection lasts for a period longer than the set time t_{Oper} the TRIP output is activated.

The simplified logic diagram of the broken conductor check function is shown in figure [63](#)

BRCPTOC is disabled (blocked) if:

- The IED is in test mode and BRCPTOC has been blocked from the HMI test menu (*Blocked= Yes*).
- The input signal BLOCK is high.

The BLOCK input can be connected to a binary input of the IED in order to receive a block command from external devices, or can be software connected to other internal functions of the IED itself to receive a block command from internal functions.

The output trip signal TRIP is a three-phase trip. It can be used to command a trip to the circuit breaker or for alarm purpose only.

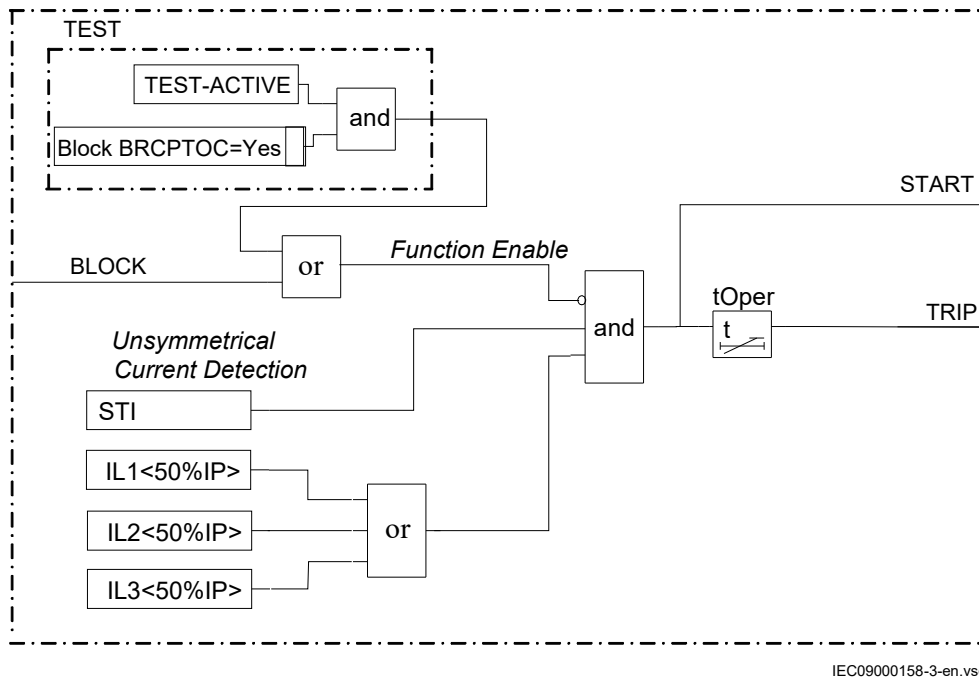

IEC09000158-3-en.vsd

Figure 63: Simplified logic diagram for Broken conductor check BRCPTOC

6.10.8 Technical data

Table 90: BRCPTOC technical data

Function	Range or value	Accuracy
Minimum phase current for operation	(5–100)% of I_{Base}	$\pm 1.0\%$ of I_r
Unbalance current operation	(50–90)% of maximum current	$\pm 2.0\%$ of I_r
Timer	(0.00–60.000) s	$\pm 0.5\% \pm 25$ ms
Operate time for start function	35 ms typically	-
Reset time for start function	30 ms typically	-
Critical impulse time	15 ms typically	-
Impulse margin time	10 ms typically	-

6.11 Directional over-/under-power protection GOPPDOP/GUPPDUP

6.11.1 Functionality

The directional over-/under-power protection GOPPDOP/GUPPDUP can be used wherever a high/low active, reactive or apparent power protection or alarming is required. The functions can alternatively be used to check the direction of active or reactive power flow in the power system. There are a number of applications where such functionality is needed. Some of them are:

- detection of reversed active power flow
- detection of high reactive power flow

Each function has two steps with definite time delay.

6.11.2 Directional overpower protection GOPPDOP

6.11.2.1 Identification

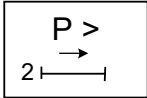
Function description	IEC 61850 identification	IEC 60617 identification	ANSI/IEEE C37.2 device number
Directional overpower protection	GOPPDOP		32

6.11.2.2 Function block

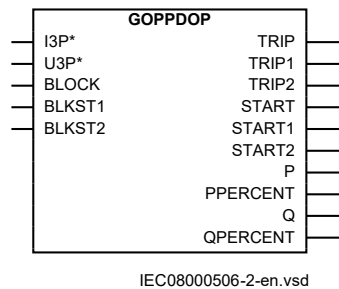

Figure 64: GOPPDOP function block

6.11.2.3 Signals

Table 91: GOPPDOP Input signals

Name	Type	Default	Description
I3P	GROUP SIGNAL	-	Three phase group signal for current inputs
U3P	GROUP SIGNAL	-	Three phase group signal for voltage inputs
BLOCK	BOOLEAN	0	Block of function
BLKST1	BOOLEAN	0	Block of step 1
BLKST2	BOOLEAN	0	Block of step 2

Table 92: GOPPDOP Output signals

Name	Type	Description
TRIP	BOOLEAN	General trip signal
TRIP1	BOOLEAN	Trip signal from stage 1
TRIP2	BOOLEAN	Trip signal from stage 2
START	BOOLEAN	General start signal
START1	BOOLEAN	Start signal from stage 1
START2	BOOLEAN	Start signal from stage 2
P	REAL	Active Power
PPERCENT	REAL	Active power in % of calculated power base value
Q	REAL	Reactive power
QPERCENT	REAL	Reactive power in % of calculated power base value

6.11.2.4 Settings

Table 93: GOPPDOP Group settings (basic)

Name	Values (Range)	Unit	Step	Default	Description
Operation	Off On	-	-	Off	Operation Off / On
OpMode1	Off OverPower	-	-	OverPower	Operation mode 1
Power1	0.0 - 500.0	%	0.1	1.0	Power setting for stage 1 in % of calculated power base value
Angle1	-180.0 - 180.0	Deg	0.1	0.0	Characteristic angle for stage 1
TripDelay1	0.010 - 6000.000	s	0.001	1.000	Trip delay for stage 1
OpMode2	Off OverPower	-	-	OverPower	Operation mode 2
Power2	0.0 - 500.0	%	0.1	1.0	Power setting for stage 2 in % of calculated power base value
Angle2	-180.0 - 180.0	Deg	0.1	0.0	Characteristic angle for stage 2
TripDelay2	0.010 - 6000.000	s	0.001	1.000	Trip delay for stage 2

Table 94: GOPPDOP Group settings (advanced)

Name	Values (Range)	Unit	Step	Default	Description
k	0.00 - 0.99	-	0.01	0.00	Low pass filter coefficient for power measurement, U and I

Table 95: GOPPDOP Non group settings (basic)

Name	Values (Range)	Unit	Step	Default	Description
GlobalBaseSel	1 - 6	-	1	1	Selection of one of the Global Base Value groups
Mode	L1, L2, L3 Arone Pos Seq L1L2 L2L3 L3L1 L1 L2 L3	-	-	Pos Seq	Mode of measurement for current and voltage

6.11.2.5 Monitored data

Table 96: GOPPDOP Monitored data

Name	Type	Values (Range)	Unit	Description
P	REAL	-	MW	Active Power
PPERCENT	REAL	-	%	Active power in % of calculated power base value
Q	REAL	-	MVAR	Reactive power
QPERCENT	REAL	-	%	Reactive power in % of calculated power base value

6.11.3 Directional underpower protection GUPPDUP

6.11.3.1 Identification

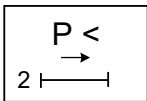
Function description	IEC 61850 identification	IEC 60617 identification	ANSI/IEEE C37.2 device number
Directional underpower protection	GUPPDUP		37

6.11.3.2 Function block

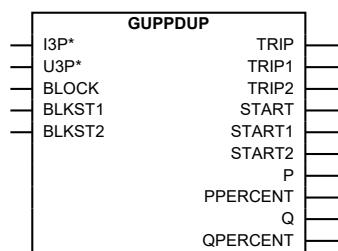

Figure 65: GUPPDUP function block

6.11.3.3 Signals

Table 97: GUPPDUP Input signals

Name	Type	Default	Description
I3P	GROUP SIGNAL	-	Three phase group signal for current inputs
U3P	GROUP SIGNAL	-	Three phase group signal for voltage inputs
BLOCK	BOOLEAN	0	Block of function
BLKST1	BOOLEAN	0	Block of step 1
BLKST2	BOOLEAN	0	Block of step 2

Table 98: GUPPDUP Output signals

Name	Type	Description
TRIP	BOOLEAN	General trip signal
TRIP1	BOOLEAN	Trip signal from stage 1
TRIP2	BOOLEAN	Trip signal from stage 2
START	BOOLEAN	General start signal
START1	BOOLEAN	Start signal from stage 1
START2	BOOLEAN	Start signal from stage 2
P	REAL	Active Power
PPERCENT	REAL	Active power in % of calculated power base value
Q	REAL	Reactive power
QPERCENT	REAL	Reactive power in % of calculated power base value

6.11.3.4 Settings

Table 99: GUPPDUP Group settings (basic)

Name	Values (Range)	Unit	Step	Default	Description
Operation	Off On	-	-	Off	Operation Off / On
OpMode1	Off UnderPower	-	-	UnderPower	Operation mode 1
Power1	0.0 - 500.0	%	0.1	1.0	Power setting for stage 1 in % of calculated power base value
Angle1	-180.0 - 180.0	Deg	0.1	0.0	Characteristic angle for stage 1
TripDelay1	0.010 - 6000.000	s	0.001	1.000	Trip delay for stage 1
OpMode2	Off UnderPower	-	-	UnderPower	Operation mode 2
Power2	0.0 - 500.0	%	0.1	1.0	Power setting for stage 2 in % of calculated power base value
Angle2	-180.0 - 180.0	Deg	0.1	0.0	Characteristic angle for stage 2
TripDelay2	0.010 - 6000.000	s	0.001	1.000	Trip delay for stage 2

Table 100: GUPPDUP Group settings (advanced)

Name	Values (Range)	Unit	Step	Default	Description
k	0.00 - 0.99	-	0.01	0.00	Low pass filter coefficient for power measurement, U and I

Table 101: GUPPDUP Non group settings (basic)

Name	Values (Range)	Unit	Step	Default	Description
GlobalBaseSel	1 - 6	-	1	1	Selection of one of the Global Base Value groups
Mode	L1, L2, L3 Arone Pos Seq L1L2 L2L3 L3L1 L1 L2 L3	-	-	Pos Seq	Mode of measurement for current and voltage

6.11.3.5 Monitored data

Table 102: GUPPDUP Monitored data

Name	Type	Values (Range)	Unit	Description
P	REAL	-	MW	Active Power
PPERCENT	REAL	-	%	Active power in % of calculated power base value
Q	REAL	-	MVAr	Reactive power
QPERCENT	REAL	-	%	Reactive power in % of calculated power base value

6.11.4 Operation principle

A simplified scheme showing the principle of the power protection function is shown in figure [66](#). The function has two stages with individual settings.

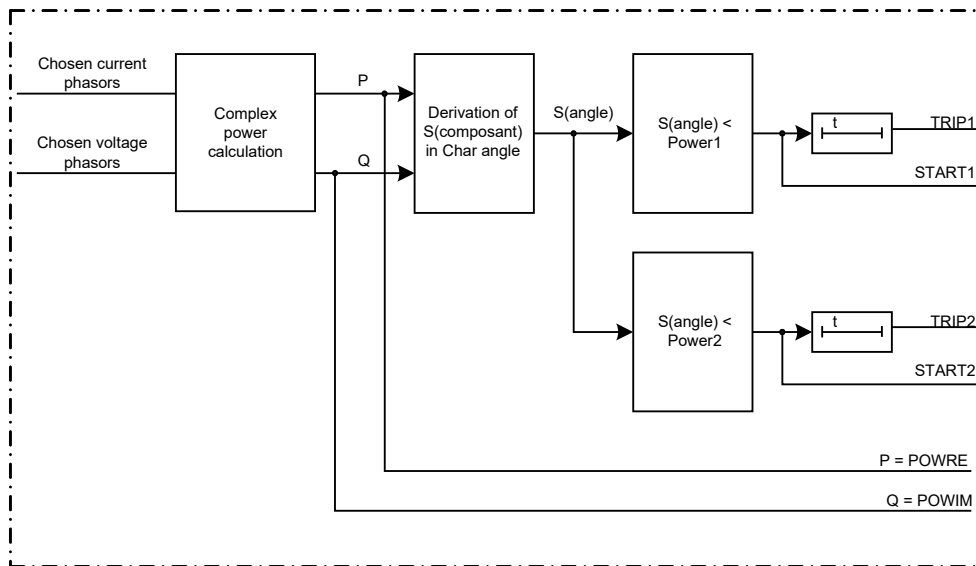

IEC09000018-2-en.vsd

Figure 66: Simplified logic diagram of the power protection function

The function will use voltage and current phasors calculated in the pre-processing blocks. The apparent complex power is calculated according to chosen formula as shown in table 103.

Table 103: Complex power calculation

Set value: Mode	Formula used for complex power calculation
L1, L2, L3	$\bar{S} = \bar{U}_{L1} \cdot \bar{I}_{L1}^* + \bar{U}_{L2} \cdot \bar{I}_{L2}^* + \bar{U}_{L3} \cdot \bar{I}_{L3}^*$ (Equation 21)
Arone	$\bar{S} = \bar{U}_{L1L2} \cdot \bar{I}_{L1}^* - \bar{U}_{L2L3} \cdot \bar{I}_{L3}^*$ (Equation 22)
PosSeq	$\bar{S} = 3 \cdot \bar{U}_{PosSeq} \cdot \bar{I}_{PosSeq}^*$ (Equation 23)
L1L2	$\bar{S} = \bar{U}_{L1L2} \cdot (\bar{I}_{L1}^* - \bar{I}_{L2}^*)$ (Equation 24)
L2L3	$\bar{S} = \bar{U}_{L2L3} \cdot (\bar{I}_{L2}^* - \bar{I}_{L3}^*)$ (Equation 25)
L3L1	$\bar{S} = \bar{U}_{L3L1} \cdot (\bar{I}_{L3}^* - \bar{I}_{L1}^*)$ (Equation 26)
L1	$\bar{S} = 3 \cdot \bar{U}_{L1} \cdot \bar{I}_{L1}^*$ (Equation 27)
L2	$\bar{S} = 3 \cdot \bar{U}_{L2} \cdot \bar{I}_{L2}^*$ (Equation 28)
L3	$\bar{S} = 3 \cdot \bar{U}_{L3} \cdot \bar{I}_{L3}^*$ (Equation 29)

The active and reactive power is available from the function and can be used for monitoring and fault recording.

The component of the complex power $S = P + jQ$ in the direction $Angle1(2)$ is calculated. If this angle is 0° the active power component P is calculated. If this angle is 90° the reactive power component Q is calculated.

The calculated power component is compared to the power pick up setting $Power1(2)$. For directional underpower protection, a start signal $START1(2)$ is activated if the calculated power component is smaller than the pick up value. For directional overpower protection, a start signal $START1(2)$ is activated if the calculated power component is larger than the pick up value. After a set time delay $TripDelay1(2)$ a trip $TRIP1(2)$ signal is activated if the start signal is still active. At activation of any of the two stages a common signal $START$ will be activated. At trip from any of the two stages also a common signal $TRIP$ will be activated.

To avoid instability there is a hysteresis in the power function. The absolute hysteresis for stage 1(2) is 0.5 p.u. for $Power1(2) \geq 1.0$ p.u., else the hysteresis is $0.5 \cdot Power1(2)$.

If the measured power drops under the $(Power1(2) - \text{hysteresis})$ value, the over-power function will reset after 0.06 seconds. If the measured power comes over the $(Power1(2) + \text{hysteresis})$ value, the under-power function will reset after 0.06 seconds. The reset means that the start signal will drop out and that the timer of the stage will reset.

6.11.4.1 Low pass filtering

In order to minimize the influence of the noise signal on the measurement it is possible to introduce the recursive, low pass filtering of the measured values for S (P , Q). This will make slower measurement response to the step changes in the measured quantity. Filtering is performed in accordance with the following recursive formula:

$$S = k \cdot S_{Old} + (1 - k) \cdot S_{Calculated}$$

(Equation 30)

Where

S	is a new measured value to be used for the protection function
S_{Old}	is the measured value given from the function in previous execution cycle
$S_{Calculated}$	is the new calculated value in the present execution cycle
k	is settable parameter by the end user which influence the filter properties
TD	

Default value for parameter k is 0.00 . With this value the new calculated value is immediately given out without any filtering (that is without any additional delay). When k is set to value bigger than 0, the filtering is enabled. A typical value for $k=0.92$ in case of slow operating functions.

6.11.5 Technical data

Table 104: GOPPDOP, GUPPDUP technical data

Function	Range or value	Accuracy
Power level	(0.0–500.0)% of <i>SBase</i>	± 1.0% of S_r at $S < S_r$ ± 1.0% of S at $S > S_r$
	(1.0-2.0)% of <i>SBase</i>	< ± 50% of set value
	(2.0-10)% of <i>SBase</i>	< ± 20% of set value
Characteristic angle	(-180.0–180.0) degrees	2 degrees
Timers	(0.010 - 6000.000) s	± 0.5% ± 25 ms

6.12 Negative sequence based overcurrent function DNSPTOC

6.12.1 Identification

Function description	IEC 61850 identification	IEC 60617 identification	ANSI/IEEE C37.2 device number
Negative sequence based overcurrent function	DNSPTOC	<div style="border: 1px solid black; padding: 5px; display: inline-block;">3I2></div>	46

6.12.2 Functionality

Negative sequence based overcurrent function DNSPTOC is typically used as sensitive earth-fault protection of power lines, where incorrect zero sequence polarization may result from mutual induction between two or more parallel lines.

Additionally, it is applied in applications on cables, where zero sequence impedance depends on the fault current return paths, but the cable negative sequence impedance is practically constant.

The directional function is current and voltage polarized. The function can be set to forward, reverse or non-directional independently for each step. Both steps are provided with a settable definite time delay.

DNSPTOC protects against all unbalanced faults including phase-to-phase faults. The minimum start current of the function must be set to above the normal system unbalance level in order to avoid unwanted operation.

6.12.3 Function block

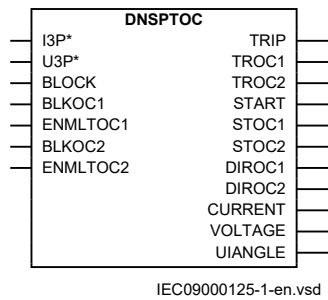

Figure 67: DNSPTOC function block

6.12.4 Signals

Table 105: DNSPTOC Input signals

Name	Type	Default	Description
I3P	GROUP SIGNAL	-	Three phase group signal for current inputs
U3P	GROUP SIGNAL	-	Three phase group signal for voltage inputs
BLOCK	BOOLEAN	0	Block of function
BLKOC1	BOOLEAN	0	Block of over current function OC1
ENMLTOC1	BOOLEAN	0	Enable signal for current multiplier - step1 (OC1)
BLKOC2	BOOLEAN	0	Block of over current function OC2
ENMLTOC2	BOOLEAN	0	Enable signal for current multiplier - step 2 (OC2)

Table 106: DNSPTOC Output signals

Name	Type	Description
TRIP	BOOLEAN	General trip signal
TROC1	BOOLEAN	Trip signal from step 1 (OC1)
TROC2	BOOLEAN	Trip signal from step 2 (OC2)
START	BOOLEAN	General start signal
STOC1	BOOLEAN	Start signal from step 1 (OC1)
STOC2	BOOLEAN	Start signal from step 2 (OC2)
DIROC1	INTEGER	Directional mode of step 1(non-directional, forward, reverse)
DIROC2	INTEGER	Directional mode of step 2 (non-directional, forward, reverse)
CURRENT	REAL	Measured current value
VOLTAGE	REAL	Measured voltage value
UIANGLE	REAL	Angle between voltage and current

6.12.5 Settings

Table 107: DNSPTOC Group settings (basic)

Name	Values (Range)	Unit	Step	Default	Description
Operation	Off On	-	-	Off	Operation Off / On
RCADir	-180 - 180	Deg	1	-75	Relay characteristic angle
ROADir	1 - 90	Deg	1	75	Relay operate angle
LowVolt_VM	0.0 - 5.0	%UB	0.1	0.5	Voltage level in % of Ubase below which ActLowVolt control takes over
Operation_OC1	Off On	-	-	Off	Operation Off/On for step 1 (OC1)
StartCurr_OC1	2.0 - 200.0	%IB	1.0	10.0	Operate current level in % of IBase for step 1 (OC1)
CurrMult_OC1	1.0 - 10.0	-	0.1	2.0	Multiplier for current operate level for step 1 (OC1)
tDef_OC1	0.00 - 6000.00	s	0.01	0.50	Independent (definite) time delay for step 1 (OC1)
DirMode_OC1	Non-directional Forward Reverse	-	-	Non-directional	Directional mode of step 1 (non-directional, forward, reverse)
DirPrinc_OC1	I&U IcosPhi&U	-	-	I&U	Measuring on I & U or IcosPhi & U for step 1 (OC1)
ActLowVolt1_VM	Non-directional Block	-	-	Block	Low voltage level action for step 1 (Non-directional, Block, Memory)
Operation_OC2	Off On	-	-	Off	Operation Off/On for step 2 (OC2)
StartCurr_OC2	2.0 - 200.0	%IB	1.0	10.0	Operate current level in % of Ibase for step 2 (OC2)
CurrMult_OC2	1.0 - 10.0	-	0.1	2.0	Multiplier for current operate level for step 2 (OC2)
tDef_OC2	0.00 - 6000.00	s	0.01	0.50	Independent (definite) time delay for step 2 (OC2)
DirMode_OC2	Non-directional Forward Reverse	-	-	Non-directional	Directional mode of step 2 (non-directional, forward, reverse)
DirPrinc_OC2	I&U IcosPhi&U	-	-	I&U	Measuring on I & U or IcosPhi & U for step 2 (OC2)
ActLowVolt2_VM	Non-directional Block	-	-	Block	Low voltage level action for step 2 (Non-directional, Block, Memory)

Table 108: DNSPTOC Non group settings (basic)

Name	Values (Range)	Unit	Step	Default	Description
GlobalBaseSel	1 - 6	-	1	1	Selection of one of the Global Base Value groups

6.12.6 Monitored data

Table 109: DNSPTOC Monitored data

Name	Type	Values (Range)	Unit	Description
CURRENT	REAL	-	A	Measured current value
VOLTAGE	REAL	-	kV	Measured voltage value
UIANGLE	REAL	-	deg	Angle between voltage and current

6.12.7 Operation principle

Negative sequence based overcurrent function (DNSPTOC) has two settable current levels, setting parameters *StartCurr_OC1* and *StartCurr_OC2*. Both features have definite time characteristics with settings *tDef_OC1* and *tDef_OC2* respectively. It is possible to change the direction of these steps to *forward*, *reverse* or *non-directional* by setting parameters *DirMode_OC1* and *DirMode_OC2*. At too low polarizing voltage the overcurrent feature can be either blocked or non-directional. This is controlled by settings *ActLowVolt1_VM* and *ActLowVolt2_VM*.

6.12.8 Technical data

Table 110: DNSPTOC Technical data

Function	Range or value	Accuracy
Operate current	(2.0 - 200.0) % of <i>I_{Base}</i>	± 1.0% of <i>I_r</i> at $I < I_r$ ± 1.0% of I at $I > I_r$
Reset ratio	> 95 %	-
Low polarizing voltage level	(0.0 - 5.0) % of <i>U_{Base}</i>	< ± 0.5% of <i>U_r</i>
Relay characteristic angle	(-180 - 180) degrees	± 2.0 degrees
Relay operate angle	(1 - 90) degrees	± 2.0 degrees
Timers	(0.00 - 6000.00) s	± 0.5% ± 25 ms
Operate time, non-directional	30 ms typically at 0 to 2 × <i>I_{set}</i> 20 ms typically at 0 to 10 × <i>I_{set}</i>	-
Reset time, non-directional	40 ms typically at 2 to 0 × <i>I_{set}</i>	-
Operate time, directional	30 ms typically at 0 to 2 × <i>I_{set}</i> 20 ms typically at 0 to 10 × <i>I_{set}</i>	-
Reset time, directional	40 ms typically at 2 to 0 × <i>I_{set}</i>	-
Critical impulse time	10 ms typically at 0 to 2 × <i>I_{set}</i> 2 ms typically at 0 to 10 × <i>I_{set}</i>	-
Impulse margin time	15 ms typically	-
Dynamic overreach	< 10% at t = 300 ms	-

Section 7 Voltage protection

7.1 Two step undervoltage protection UV2PTUV

7.1.1 Identification

Function description	IEC 61850 identification	IEC 60617 identification	ANSI/IEEE C37.2 device number
Two step undervoltage protection	UV2PTUV	<div style="border: 1px solid black; padding: 5px; width: fit-content; margin: 0 auto;">3U<</div>	27

7.1.2 Functionality

Undervoltages can occur in the power system during faults or abnormal conditions. Two step undervoltage protection (UV2PTUV) function can be used to open circuit breakers to prepare for system restoration at power outages or as long-time delayed back-up to primary protection.

UV2PTUV has two voltage steps, where step 1 is settable as inverse or definite time delayed. Step 2 is always definite time delayed.

UV2PTUV has a high reset ratio to allow settings close to system service voltage.

7.1.3 Function block

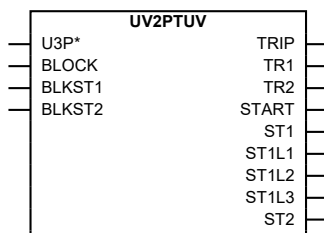

IEC09000285_1_en.vsd

Figure 68: UV2PTUV function block

7.1.4 Signals

Table 111: UV2PTUV Input signals

Name	Type	Default	Description
U3P	GROUP SIGNAL	-	Three phase group signal for voltage inputs
BLOCK	BOOLEAN	0	Block of function
BLKST1	BOOLEAN	0	Block of step 1
BLKST2	BOOLEAN	0	Block of step 2

Table 112: UV2PTUV Output signals

Name	Type	Description
TRIP	BOOLEAN	General trip signal
TR1	BOOLEAN	Trip signal from step 1
TR2	BOOLEAN	Trip signal from step 2
START	BOOLEAN	General start signal
ST1	BOOLEAN	Start signal from step 1
ST1L1	BOOLEAN	Start signal from step 1 phase L1
ST1L2	BOOLEAN	Start signal from step 1 phase L2
ST1L3	BOOLEAN	Start signal from step 1 phase L3
ST2	BOOLEAN	Start signal from step 2

7.1.5 Settings

Table 113: UV2PTUV Group settings (basic)

Name	Values (Range)	Unit	Step	Default	Description
Operation	Off On	-	-	Off	Operation Off / On
OperationStep1	Off On	-	-	On	Enable execution of step 1
Characterist1	Definite time Inverse curve A Inverse curve B	-	-	Definite time	Selection of time delay curve type for step 1
OpMode1	1 out of 3 2 out of 3 3 out of 3	-	-	1 out of 3	Number of phases required to operate (1 of 3, 2 of 3, 3 of 3) from step 1
U1<	1 - 100	%UB	1	70	Voltage start value (DT & IDMT) in % of UBase for step 1
t1	0.00 - 6000.00	s	0.01	5.00	Definite time delay of step 1
t1Min	0.000 - 60.000	s	0.001	5.000	Minimum operate time for inverse curves for step 1
k1	0.05 - 1.10	-	0.01	0.05	Time multiplier for the inverse time delay for step 1
OperationStep2	Off On	-	-	On	Enable execution of step 2

Table continues on next page

Name	Values (Range)	Unit	Step	Default	Description
OpMode2	1 out of 3 2 out of 3 3 out of 3	-	-	1 out of 3	Number of phases required to operate (1 of 3, 2 of 3, 3 of 3) from step 2
U2<	1 - 100	%UB	1	50	Voltage start value (DT & IDMT) in % of UBase for step 2
t2	0.000 - 60.000	s	0.001	5.000	Definie time delay of step 2

Table 114: UV2PTUV Non group settings (basic)

Name	Values (Range)	Unit	Step	Default	Description
GlobalBaseSel	1 - 6	-	1	1	Selection of one of the Global Base Value groups
ConnType	PhN DFT PhN RMS PhPh DFT PhPh RMS	-	-	PhN DFT	Group selector for connection type

7.1.6 Monitored data

Table 115: UV2PTUV Monitored data

Name	Type	Values (Range)	Unit	Description
UL1	REAL	-	kV	Voltage in phase L1
UL2	REAL	-	kV	Voltage in phase L2
UL3	REAL	-	kV	Voltage in phase L3

7.1.7 Operation principle

Two-step undervoltage protection (UV2PTUV) is used to detect low power system voltage. UV2PTUV has two voltage measuring steps with separate time delays. If one, two or three phase voltages decrease below the set value, a corresponding START signal is generated. UV2PTUV can be set to START/TRIP based on *1 out of 3*, *2 out of 3* or *3 out of 3* of the measured voltages, being below the set point. If the voltage remains below the set value for a time period corresponding to the chosen time delay, the corresponding trip signal is issued. The time delay characteristic is settable for step 1 and can be either definite or inverse time delayed. Step 2 is always definite time delayed.

UV2PTUV can be set to measure phase-to-earth fundamental value, phase-to-phase fundamental value, phase-to-earth true RMS value or phase-to-phase true RMS value. The choice of the measuring is done by the parameter *ConnType*. The voltage related settings are made in percent of base voltage which is set in kV phase-to-phase voltage. This means operation for phase-to-earth voltage under:

$$U < (\%) \cdot UBase(kV) / \sqrt{3}$$

(Equation 31)

and operation for phase-to-phase voltage under:

$$U < (\%) \cdot U_{Base}(kV)$$

(Equation 32)



When phase-to-earth voltage measurement is selected the function automatically introduces division of the base value by the square root of three.

7.1.7.1 Measurement principle

Depending on the set *ConnType* value, UV2PTUV measures phase-to-earth or phase-to-phase voltages and compare against set values, $U1<$ and $U2<$. The parameters *OpMode1* and *OpMode2* influence the requirements to activate the START outputs. Either *1 out of 3*, *2 out of 3*, or *3 out of 3* measured voltages have to be lower than the corresponding set point to issue the corresponding START signal.

To avoid oscillations of the output START signal, a hysteresis has been included.

7.1.7.2 Time delay

The time delay for step 1 can be either definite time delay (DT) or inverse time delay (IDMT). Step 2 is always definite time delay (DT). For the inverse time delay two different modes are available; inverse curve A and inverse curve B.

The type A curve is described as:

$$t = \frac{k}{\left(\frac{U_n < -U}{U_n <} \right)}$$

(Equation 33)

The type B curve is described as:

$$t = \frac{k \cdot 480}{\left(32 \cdot \frac{U_n < -U}{U_n <} - 0.5 \right)^{2.0}} + 0.055$$

(Equation 34)

The lowest voltage is always used for the inverse time delay integration. The details of the different inverse time characteristics are shown in section [20.3 "Inverse time characteristics"](#).

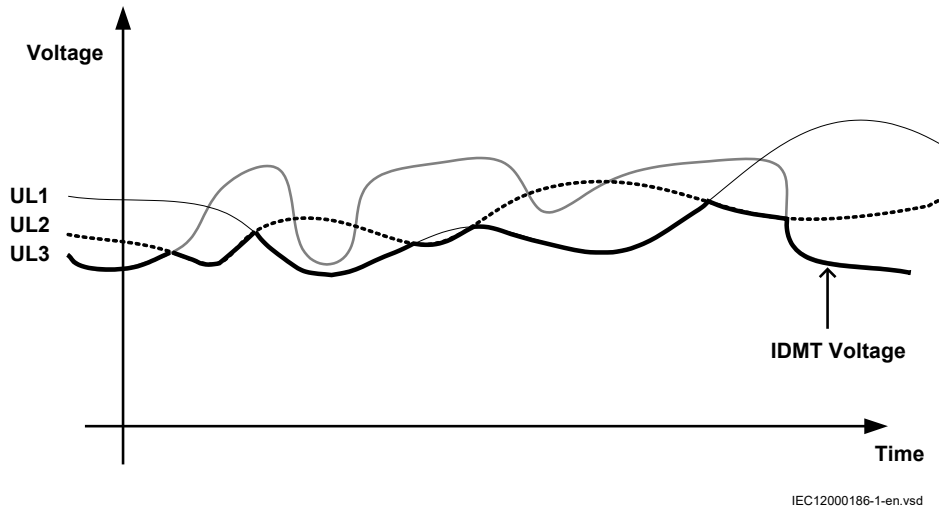

Figure 69: Voltage used for the inverse time characteristic integration

Trip signal issuing requires that the undervoltage condition continues for at least the user set time delay. This time delay is set by the parameter $t1$ and $t2$ for definite time mode (DT) and by some special voltage level dependent time curves for the inverse time mode (IDMT). If the start condition, with respect to the measured voltage ceases during the delay time, the corresponding start output is reset.

7.1.7.3 Blocking

It is possible to block Two step undervoltage protection (UV2PTUV) partially or completely, by binary input signals or by parameter settings, where:

BLOCK:	blocks all outputs
BLKST1:	blocks all start and trip outputs related to step 1
BLKST2:	blocks all start and trip outputs related to step 2

7.1.7.4 Design

The voltage measuring elements continuously measure the three phase-to-neutral voltages or the three phase-to-phase voltages. Recursive fourier filters or true RMS filters of input voltage signals are used. The voltages are individually compared to the set value, and the lowest voltage is used for the inverse time characteristic integration. A special logic is included to achieve the *1 out of 3*, *2 out of 3* and *3 out of 3* criteria to fulfill the START condition. The design of Two step undervoltage protection UV2PTUV is schematically shown in [Figure 70](#).

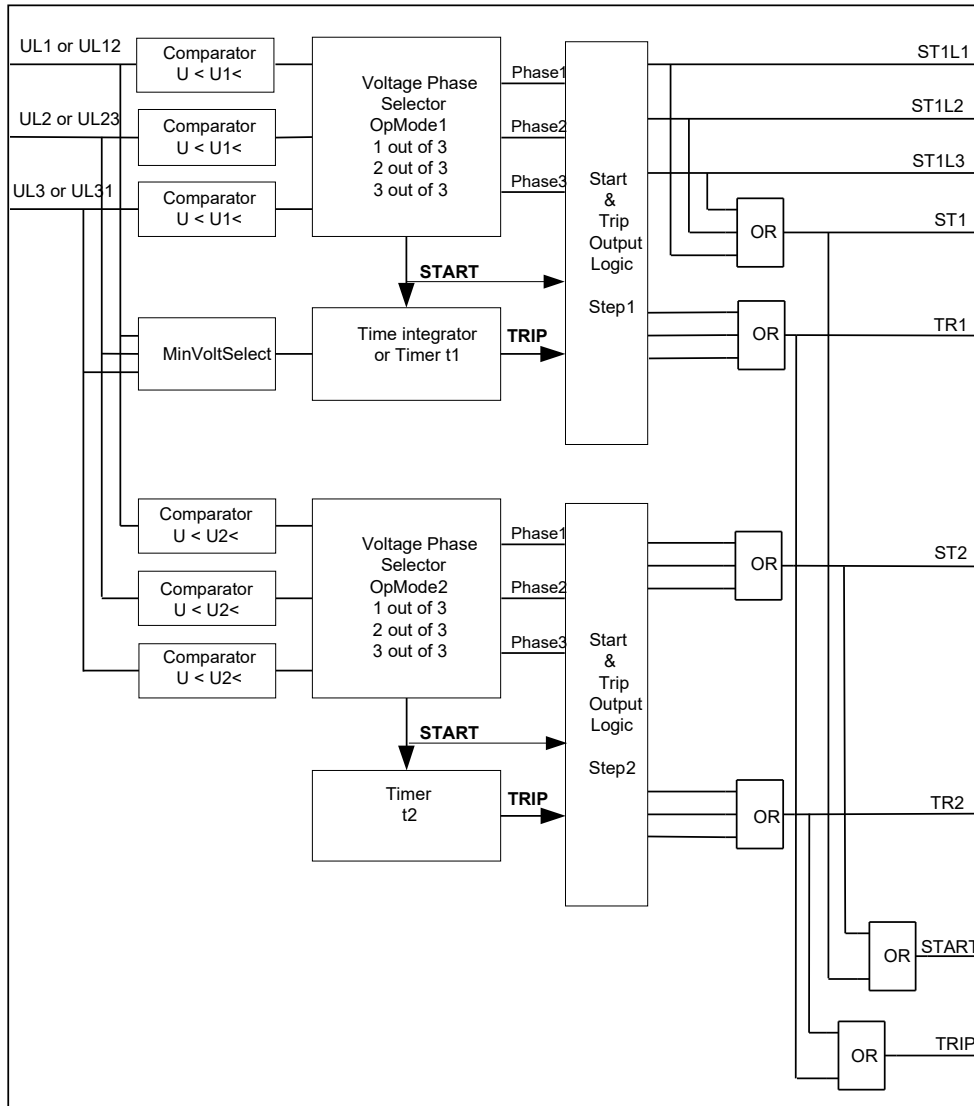

IEC08000016-3-en.vsd

Figure 70: Schematic design of Two step undervoltage protection UV2PTUV

7.1.8 Technical data

Table 116: UV2PTUV technical data

Function	Range or value	Accuracy
Operate voltage, low and high step	(1–100)% of U_{Base}	$\pm 0.5\%$ of U_r
Reset ratio	<102%	-
Inverse time characteristics for low and high step, see table 577	-	See table 577
Definite time delay, step 1	(0.00 - 6000.00) s	$\pm 0.5\% \pm 25$ ms
Definite time delays, step 2	(0.000-60.000) s	$\pm 0.5\% \pm 25$ ms
Minimum operate time, inverse characteristics	(0.000–60.000) s	$\pm 0.5\% \pm 25$ ms
Table continues on next page		

Function	Range or value	Accuracy
Operate time, start function	30 ms typically at 1.2 to 0.5U _{set}	-
Reset time, start function	40 ms typically at 0.5 to 1.2 xU _{set}	-
Critical impulse time	10 ms typically at 1.2 to 0.8 x U _{set}	-
Impulse margin time	15 ms typically	-

7.2 Two step overvoltage protection OV2PTOV

7.2.1 Identification

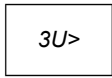
Function description	IEC 61850 identification	IEC 60617 identification	ANSI/IEEE C37.2 device number
Two step overvoltage protection	OV2PTOV		59

7.2.2 Functionality

Overvoltages may occur in the power system during abnormal conditions such as sudden power loss, tap changer regulating failures, and open line ends on long lines.

Two step overvoltage protection (OV2PTOV) function can be used to detect open line ends, normally then combined with a directional reactive over-power function to supervise the system voltage. When triggered, the function will cause an alarm, switch in reactors, or switch out capacitor banks.

OV2PTOV has two voltage steps, where step 1 can be set as inverse or definite time delayed. Step 2 is always definite time delayed.

OV2PTOV has a high reset ratio to allow settings close to system service voltage.

7.2.3 Function block

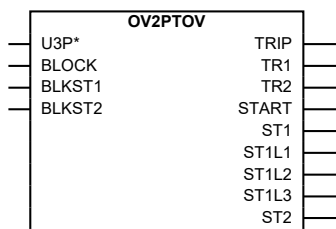

IEC09000278-2-en.vsd

Figure 71: OV2PTOV function block

7.2.4 Signals

Table 117: OV2PTOV Input signals

Name	Type	Default	Description
U3P	GROUP SIGNAL	-	Three phase group signal for voltage inputs
BLOCK	BOOLEAN	0	Block of function
BLKST1	BOOLEAN	0	Block of step 1
BLKST2	BOOLEAN	0	Block of step 2

Table 118: OV2PTOV Output signals

Name	Type	Description
TRIP	BOOLEAN	General trip signal
TR1	BOOLEAN	Trip signal from step 1
TR2	BOOLEAN	Trip signal from step 2
START	BOOLEAN	General start signal
ST1	BOOLEAN	Start signal from step 1
ST1L1	BOOLEAN	Start signal from step 1 phase L1
ST1L2	BOOLEAN	Start signal from step 1 phase L2
ST1L3	BOOLEAN	Start signal from step 1 phase L3
ST2	BOOLEAN	Start signal from step 2

7.2.5 Settings

Table 119: OV2PTOV Group settings (basic)

Name	Values (Range)	Unit	Step	Default	Description
Operation	Off On	-	-	Off	Operation Off / On
OperationStep1	Off On	-	-	On	Enable execution of step 1
Characterist1	Definite time Inverse curve A Inverse curve B Inverse curve C	-	-	Definite time	Selection of time delay curve type for step 1
OpMode1	1 out of 3 2 out of 3 3 out of 3	-	-	1 out of 3	Number of phases required to operate (1 of 3, 2 of 3, 3 of 3) from step 1
U1>	1 - 200	%UB	1	120	Voltage start value (DT & IDMT) in % of UBase for step 1
t1	0.00 - 6000.00	s	0.01	5.00	Definite time delay of step 1
t1Min	0.000 - 60.000	s	0.001	5.000	Minimum operate time for inverse curves for step 1
k1	0.05 - 1.10	-	0.01	0.05	Time multiplier for the inverse time delay for step 1

Table continues on next page

Name	Values (Range)	Unit	Step	Default	Description
OperationStep2	Off On	-	-	On	Enable execution of step 2
OpMode2	1 out of 3 2 out of 3 3 out of 3	-	-	1 out of 3	Number of phases required to operate (1 of 3, 2 of 3, 3 of 3) from step 2
U2>	1 - 200	%UB	1	150	Voltage start value (DT & IDMT) in % of UBase for step 2
t2	0.000 - 60.000	s	0.001	5.000	Definite time delay of step 2

Table 120: OV2PTOV Non group settings (basic)

Name	Values (Range)	Unit	Step	Default	Description
GlobalBaseSel	1 - 6	-	1	1	Selection of one of the Global Base Value groups
ConnType	PhN DFT PhN RMS PhPh DFT PhPh RMS	-	-	PhN DFT	Group selector for connection type

7.2.6 Monitored data

Table 121: OV2PTOV Monitored data

Name	Type	Values (Range)	Unit	Description
UL1	REAL	-	kV	Voltage in phase L1
UL2	REAL	-	kV	Voltage in phase L2
UL3	REAL	-	kV	Voltage in phase L3

7.2.7 Operation principle

Two step overvoltage protection OV2PTOV is used to detect high power system voltage. OV2PTOV has two steps with separate time delays. If one-, two- or three-phase voltages increase above the set value, a corresponding START signal is issued. OV2PTOV can be set to START/TRIP, based on *1 out of 3*, *2 out of 3* or *3 out of 3* of the measured voltages, being above the set point. If the voltage remains above the set value for a time period corresponding to the chosen time delay, the corresponding trip signal is issued.

The time delay characteristic is settable for step 1 and can be either definite or inverse time delayed. Step 2 is always definite time delayed.

The voltage related settings are made in percent of the global set base voltage *UBase*, which is set in kV, phase-to-phase.

OV2PTOV can be set to measure phase-to-earth fundamental value, phase-to-phase fundamental value, phase-to-earth RMS value or phase-to-phase RMS value. The choice of measuring is done by the parameter *ConnType*.

The voltage related settings are made in percent of base voltage which is set in kV phase-to-phase voltage. OV2PTOV will operate if the voltage gets higher than the set percentage of the set global base voltage *UBase*. This means operation for phase-to-earth voltage over:

$$U > (\%) \cdot U_{Base}(kV) / \sqrt{3}$$

(Equation 35)

and operation for phase-to-phase voltage over:

$$U > (\%) \cdot U_{Base}(kV)$$

(Equation 36)



When phase-to-earth voltage measurement is selected the function automatically introduces division of the base value by the square root of three.

7.2.7.1 Measurement principle

All the three voltages are measured continuously, and compared with the set values, $U1>$ for Step 1 and $U2>$ for Step 2. The parameters *OpMode1* and *OpMode2* influence the requirements to activate the START outputs. Either *1 out of 3*, *2 out of 3* or *3 out of 3* measured voltages have to be higher than the corresponding set point to issue the corresponding START signal.

To avoid oscillations of the output START signal, a hysteresis is included.

7.2.7.2 Time delay

The time delay for step 1 can be either definite time delay (DT) or inverse time delay (IDMT). Step 2 is always definite time delay (DT). For the inverse time delay three different modes are available:

- inverse curve A
- inverse curve B
- inverse curve C

The type A curve is described as:

$$t = \frac{k}{\left(\frac{U - U >}{U >} \right)}$$

(Equation 37)

The type B curve is described as:

$$t = \frac{k \cdot 480}{\left(32 \cdot \frac{U - U >}{U >} - 0.5 \right)^{2.0}} - 0.035$$

(Equation 38)

The type C curve is described as:

$$t = \frac{k \cdot 480}{\left(32 \cdot \frac{U - U >}{U >} - 0.5\right)^{3.0}} + 0.035$$

(Equation 39)

The highest phase (or phase-to-phase) voltage is always used for the inverse time delay integration, see [Figure 72](#). The details of the different inverse time characteristics are shown in section "[Inverse time characteristics](#)".

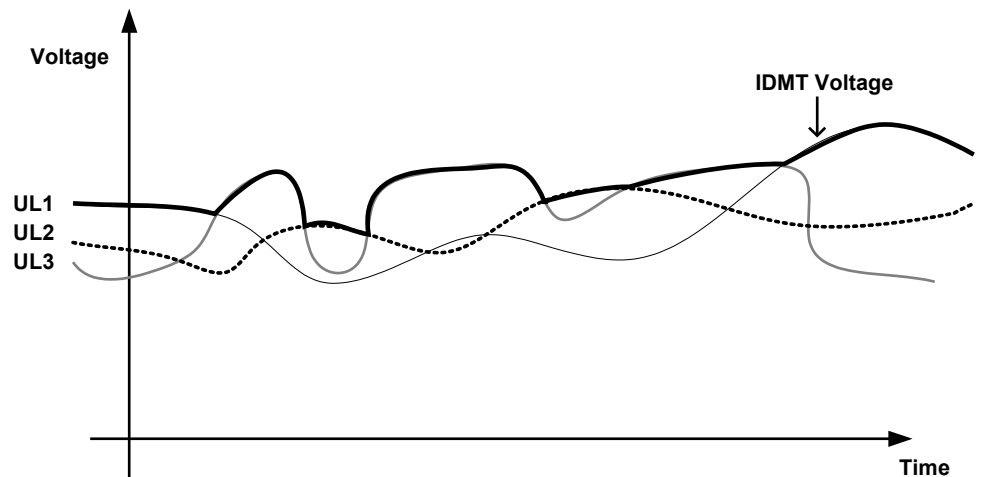

IEC05000016-2-en.vsd

Figure 72: Voltage used for the inverse time characteristic integration

A TRIP requires that the overvoltage condition continues for at least the user set time delay. This time delay is set by the parameter $t1$ and $t2$ for definite time mode (DT) and by selected voltage level dependent time curves for the inverse time mode (IDMT). If the START condition, with respect to the measured voltage ceases during the delay time, the corresponding START output is reset.

7.2.7.3 Blocking

It is possible to block two step overvoltage protection (OV2PTOV) partially or completely, by binary input signals where:

BLOCK:	blocks all outputs
BLKST1:	blocks all start and trip outputs related to step 1
BLKST2:	blocks all start and trip outputs related to step 2

7.2.7.4 Design

The voltage measuring elements continuously measure the three phase-to-earth voltages or the three phase-to-phase voltages. Recursive Fourier filters or true RMS filters of input voltage signals are used. The phase voltages are individually compared to the set value, and the highest voltage is used for the inverse time characteristic integration. A special logic is included to achieve the *1 out of 3*, *2 out of 3* or *3 out of 3* criteria to fulfill the START condition. The design of Two step overvoltage protection (OV2PTOV) is schematically described in [Figure 73](#).

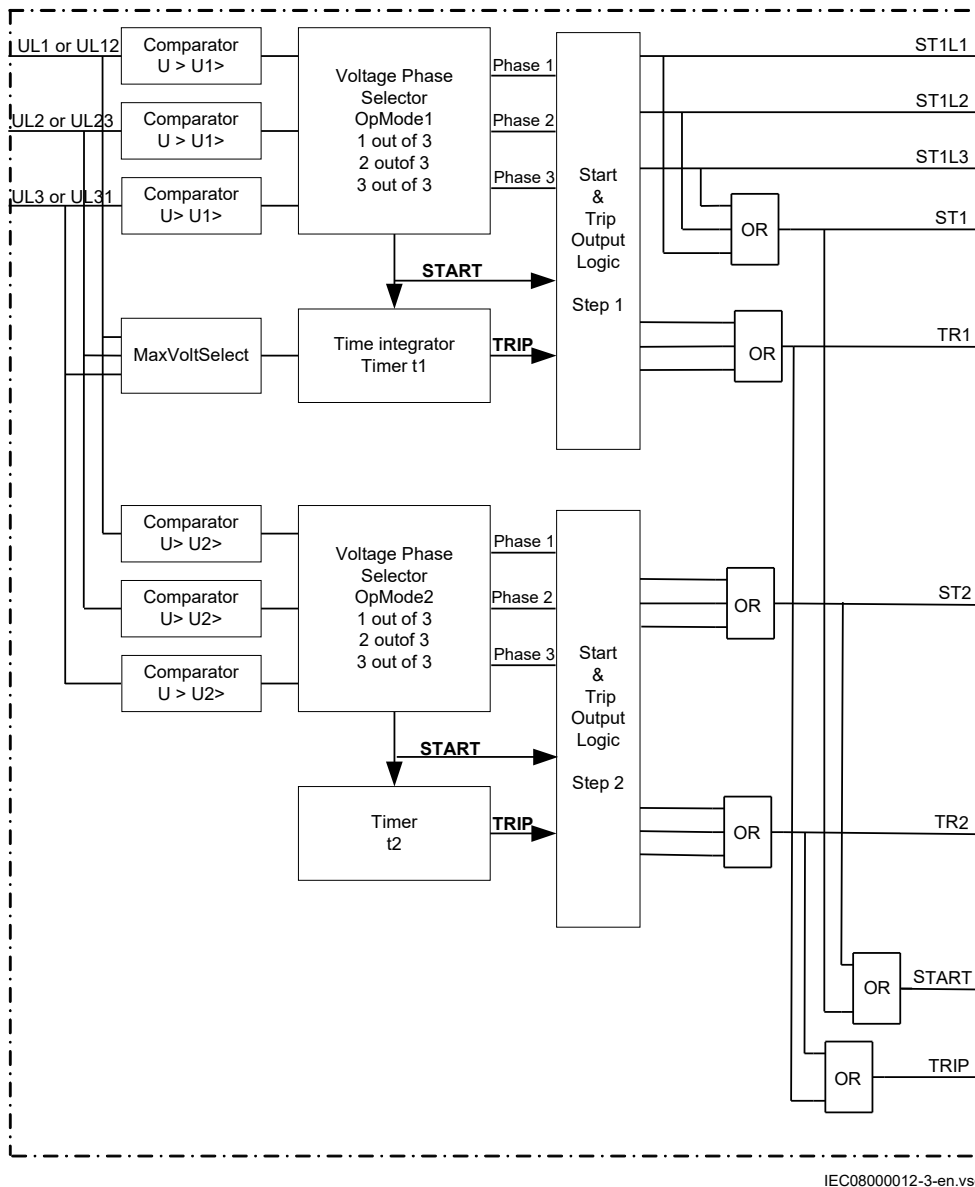

IEC0800012-3-en.vsd

Figure 73: Schematic design of Two step overvoltage protection (OV2PTOV)

7.2.8 Technical data

Table 122: OV2PTOV technical data

Function	Range or value	Accuracy
Operate voltage, step 1 and 2	(1-200)% of U_{Base}	$\pm 0.5\%$ of U_r at $U < U_r$ $\pm 0.5\%$ of U at $U > U_r$
Reset ratio	>98%	-
Inverse time characteristics for steps 1 and 2, see table "___"	-	See table 576
Definite time delay, step 1	(0.00 - 6000.00) s	$\pm 0.5\% \pm 25$ ms
Definite time delays, step 2	(0.000-60.000) s	$\pm 0.5\% \pm 25$ ms
Table continues on next page		

Function	Range or value	Accuracy
Minimum operate time, Inverse characteristics	(0.000-60.000) s	$\pm 0.5\% \pm 25$ ms
Operate time, start function	30 ms typically at 0 to $2 \times U_{set}$	-
Reset time, start function	40 ms typically at 2 to $0 \times U_{set}$	-
Critical impulse time	10 ms typically at 0 to $2 \times U_{set}$	-
Impulse margin time	15 ms typically	-

7.3 Two step residual overvoltage protection ROV2PTOV

7.3.1 Identification

Function description	IEC 61850 identification	IEC 60617 identification	ANSI/IEEE C37.2 device number
Two step residual overvoltage protection	ROV2PTOV	<div style="border: 1px solid black; padding: 5px; width: fit-content; margin: 0 auto;"> $3U0>$ </div>	59N

7.3.2 Functionality

Residual voltages may occur in the power system during earth faults.

Two step residual overvoltage protection ROV2PTOV function calculates the residual voltage from the three-phase voltage input transformers or measures it from a single voltage input transformer fed from an open delta or neutral point voltage transformer.

ROV2PTOV has two voltage steps, where step 1 can be set as inverse or definite time delayed. Step 2 is always definite time delayed.

7.3.3 Function block

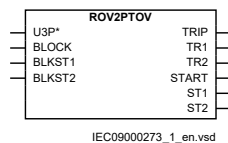

Figure 74: ROV2PTOV function block

7.3.4 Signals

Table 123: ROV2PTOV Input signals

Name	Type	Default	Description
U3P	GROUP SIGNAL	-	Three phase group signal for voltage inputs
BLOCK	BOOLEAN	0	Block of function
BLKST1	BOOLEAN	0	Block of step 1
BLKST2	BOOLEAN	0	Block of step 2

Table 124: ROV2PTOV Output signals

Name	Type	Description
TRIP	BOOLEAN	General trip signal
TR1	BOOLEAN	Trip signal from step 1
TR2	BOOLEAN	Trip signal from step 2
START	BOOLEAN	General start signal
ST1	BOOLEAN	Start signal from step 1
ST2	BOOLEAN	Start signal from step 2

7.3.5 Settings

Table 125: ROV2PTOV Group settings (basic)

Name	Values (Range)	Unit	Step	Default	Description
Operation	Off On	-	-	Off	Operation Off / On
OperationStep1	Off On	-	-	On	Enable execution of step 1
Characterist1	Definite time Inverse curve A Inverse curve B Inverse curve C	-	-	Definite time	Selection of time delay curve type for step 1
U1>	1 - 200	%UB	1	30	Voltage start value (DT & IDMT) in % of UBase for step 1
t1	0.00 - 6000.00	s	0.01	5.00	Definite time delay of step 1
t1Min	0.000 - 60.000	s	0.001	5.000	Minimum operate time for inverse curves for step 1
k1	0.05 - 1.10	-	0.01	0.05	Time multiplier for the inverse time delay for step 1
OperationStep2	Off On	-	-	On	Enable execution of step 2
U2>	1 - 100	%UB	1	45	Voltage start value (DT & IDMT) in % of UBase for step 2
t2	0.000 - 60.000	s	0.001	5.000	Definite time delay of step 2

Table 126: ROV2PTOV Non group settings (basic)

Name	Values (Range)	Unit	Step	Default	Description
GlobalBaseSel	1 - 6	-	1	1	Selection of one of the Global Base Value groups

7.3.6 Monitored data

Table 127: ROV2PTOV Monitored data

Name	Type	Values (Range)	Unit	Description
ULevel	REAL	-	kV	Magnitude of measured voltage

7.3.7 Operation principle

Two step residual overvoltage protection ROV2PTOV is used to detect earth (zero sequence) overvoltages. The ground overvoltage $3U_0$ is normally computed by adding the input phase voltages. $3U_0$ may also be input single phase by either measuring directly from a voltage transformer in the neutral of a power transformer, or from a secondary broken delta connection of a transformer with a star-grounded primary. ROV2PTOV has two steps with separate time delays. If the ground overvoltage remains above the set value for a time period corresponding to the chosen time delay, the corresponding TRIP signal is issued.

The time delay characteristic is settable for step 1 and can be either definite or inverse time delayed. Step 2 is always definite time delayed.

The voltage related settings are made in percent of the global phase-to-phase base voltage divided by $\sqrt{3}$.

7.3.7.1 Measurement principle

The residual voltage is measured continuously, and compared with the set values, $U1>$ and $U2>$.

To avoid oscillations of the output START signal, a hysteresis has been included.

7.3.7.2 Time delay

7.3.7.3 Blocking

It is possible to block two step residual overvoltage protection (ROV2PTOV) partially or completely, by binary input signals where:

BLOCK:	blocks all outputs
BLKST1:	blocks all start and trip outputs related to step 1
BLKST2:	blocks all start and trip inputs related to step 2

7.3.7.4 Design

The voltage measuring elements continuously measure the residual voltage. Recursive Fourier filters filter the input voltage signal. The single input voltage is compared to the set value, and

is also used for the inverse time characteristic integration. The design of Two step residual overvoltage protection (ROV2PTOV) is schematically described in [Figure 75](#).

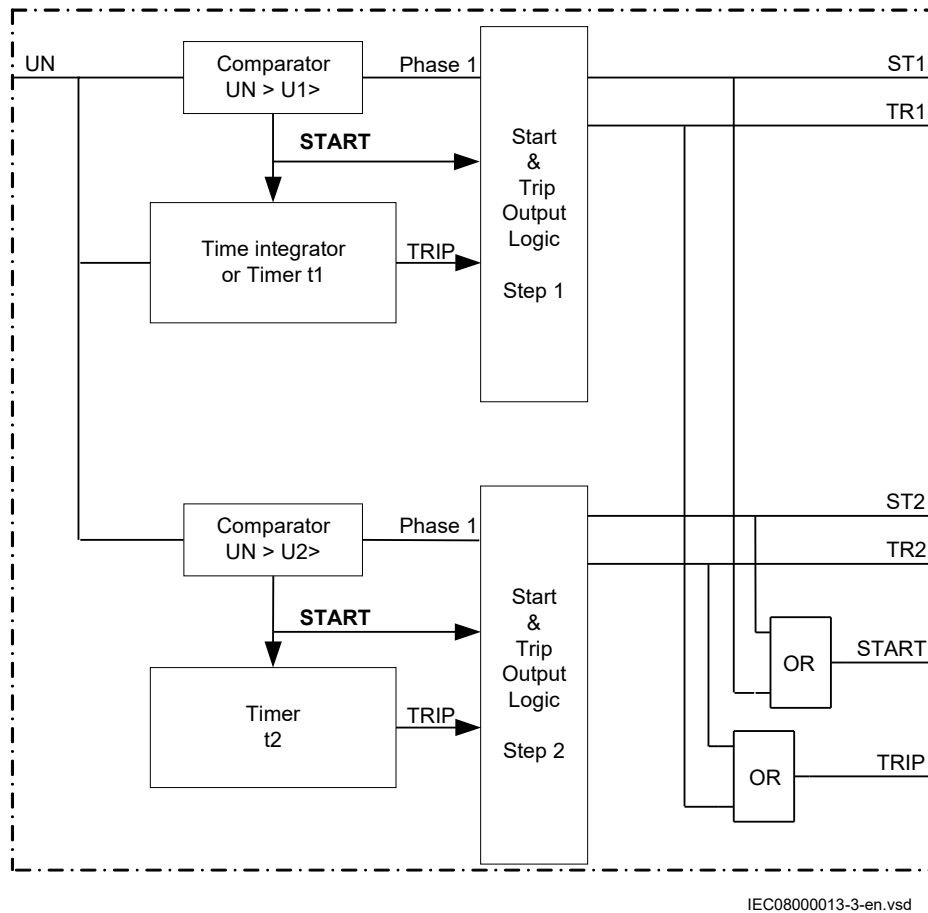

Figure 75: Schematic design of Two step residual overvoltage protection (ROV2PTOV)



The design of Two step residual overvoltage protection (ROV2PTOV) is schematically described in [Figure 75](#). UN is a signal included in the three phase group signal U3P which shall be connected to output AI3P of the SMAI. If a connection is made to the 4 input GRP_xN (x is equal to instance number 2 to 12) on the SMAI, UN is this signal else UN is the vectorial sum of the three inputs GRP_xL1 to GRP_xL3.

7.3.8 Technical data

Table 128: ROV2PTOV technical data

Function	Range or value	Accuracy
Operate voltage, step 1	(1-200)% of U_{Base}	$\pm 0.5\%$ of U_r at $U < U_r$ $\pm 0.5\%$ of U at $U > U_r$
Operate voltage, step 2	(1-100)% of U_{Base}	$\pm 0.5\%$ of U_r at $U < U_r$ $\pm 0.5\%$ of U at $U > U_r$
Reset ratio	> 98%	-
Table continues on next page		

Function	Range or value	Accuracy
Inverse time characteristics for low and high step, see table 578	-	See table 578
Definite time setting, step 1	(0.00–6000.00) s	± 0.5% ± 25 ms
Definite time setting, step 2	(0.000–60.000) s	± 0.5% ± 25 ms
Minimum operate time for step 1 inverse characteristic	(0.000–60.000) s	± 0.5% ± 25 ms
Operate time, start function	30 ms typically at 0 to 2 x U _{set}	-
Reset time, start function	40 ms typically at 2 to 0 x U _{set}	-
Critical impulse time	10 ms typically at 0 to 1.2 x U _{set}	-
Impulse margin time	15 ms typically	-

7.4 Loss of voltage check LOVPTUV

7.4.1 Identification

Function description	IEC 61850 identification	IEC 60617 identification	ANSI/IEEE C37.2 device number
Loss of voltage check	LOVPTUV	-	27

7.4.2 Functionality

Loss of voltage check LOVPTUV is suitable for use in networks with an automatic system restoration function. LOVPTUV issues a three-pole trip command to the circuit breaker, if all three phase voltages fall below the set value for a time longer than the set time and the circuit breaker remains closed.

The operation of LOVPTUV is supervised by the fuse failure supervision SDDRFUF.

7.4.3 Function block

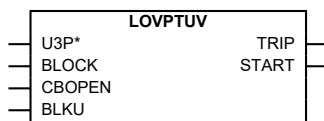

IEC09000279_1_en.vsd

Figure 76: LOVPTUV function block

7.4.4 Signals

Table 129: LOVPTUV Input signals

Name	Type	Default	Description
U3P	GROUP SIGNAL	-	Three phase group signal for voltage inputs
BLOCK	BOOLEAN	0	Block of function
CBOPEN	BOOLEAN	0	Circuit breaker open
BLKU	BOOLEAN	0	Block from voltage circuit supervision

Table 130: LOVPTUV Output signals

Name	Type	Description
TRIP	BOOLEAN	Trip signal
START	BOOLEAN	Start signal

7.4.5 Settings

Table 131: LOVPTUV Group settings (basic)

Name	Values (Range)	Unit	Step	Default	Description
Operation	Off On	-	-	Off	Operation Off/On
UPE	1 - 100	%UB	1	70	Operate voltage in% of base voltage Ubase
tTrip	0.000 - 60.000	s	0.001	7.000	Operate time delay

Table 132: LOVPTUV Group settings (advanced)

Name	Values (Range)	Unit	Step	Default	Description
tPulse	0.050 - 60.000	s	0.001	0.150	Duration of TRIP pulse
tBlock	0.000 - 60.000	s	0.001	5.000	Time delay to block when all 3ph voltages are not low
tRestore	0.000 - 60.000	s	0.001	3.000	Time delay for enable the function after restoration

Table 133: LOVPTUV Non group settings (basic)

Name	Values (Range)	Unit	Step	Default	Description
GlobalBaseSel	1 - 6	-	1	1	Selection of one of the Global Base Value groups

7.4.6 Operation principle

The operation of Loss of voltage check LOVPTUV is based on line voltage measurement. LOVPTUV is provided with a logic, which automatically recognizes if the line was restored for

at least $t_{Restore}$ before starting the t_{Trip} timer. All three phases are required to be low before the output TRIP is activated. The START output signal indicates start.

Additionally, LOVPTUV is automatically blocked if only one or two phase voltages have been detected low for more than t_{Block} .

LOVPTUV operates again only if the line has been restored to full voltage for at least $t_{Restore}$. Operation of the function is also inhibited by fuse failure and open circuit breaker information signals, by their connection to dedicated inputs of the function block.

Due to undervoltage conditions being continuous the trip pulse is limited to a length set by setting t_{Pulse} .

The operation of LOVPTUV is supervised by the fuse-failure function (BLKU input) and the information about the open position (CBOPEN) of the associated circuit breaker.

The BLOCK input can be connected to a binary input of the IED in order to receive a block command from external devices or can be software connected to other internal functions of the IED itself in order to receive a block command from internal functions. LOVPTUV is also blocked when the IED is in test mode and LOVPTUV has been blocked from the HMI test menu (*Blocked= Yes*).

LOSS OF VOLTAGE CHECK FUNCTION

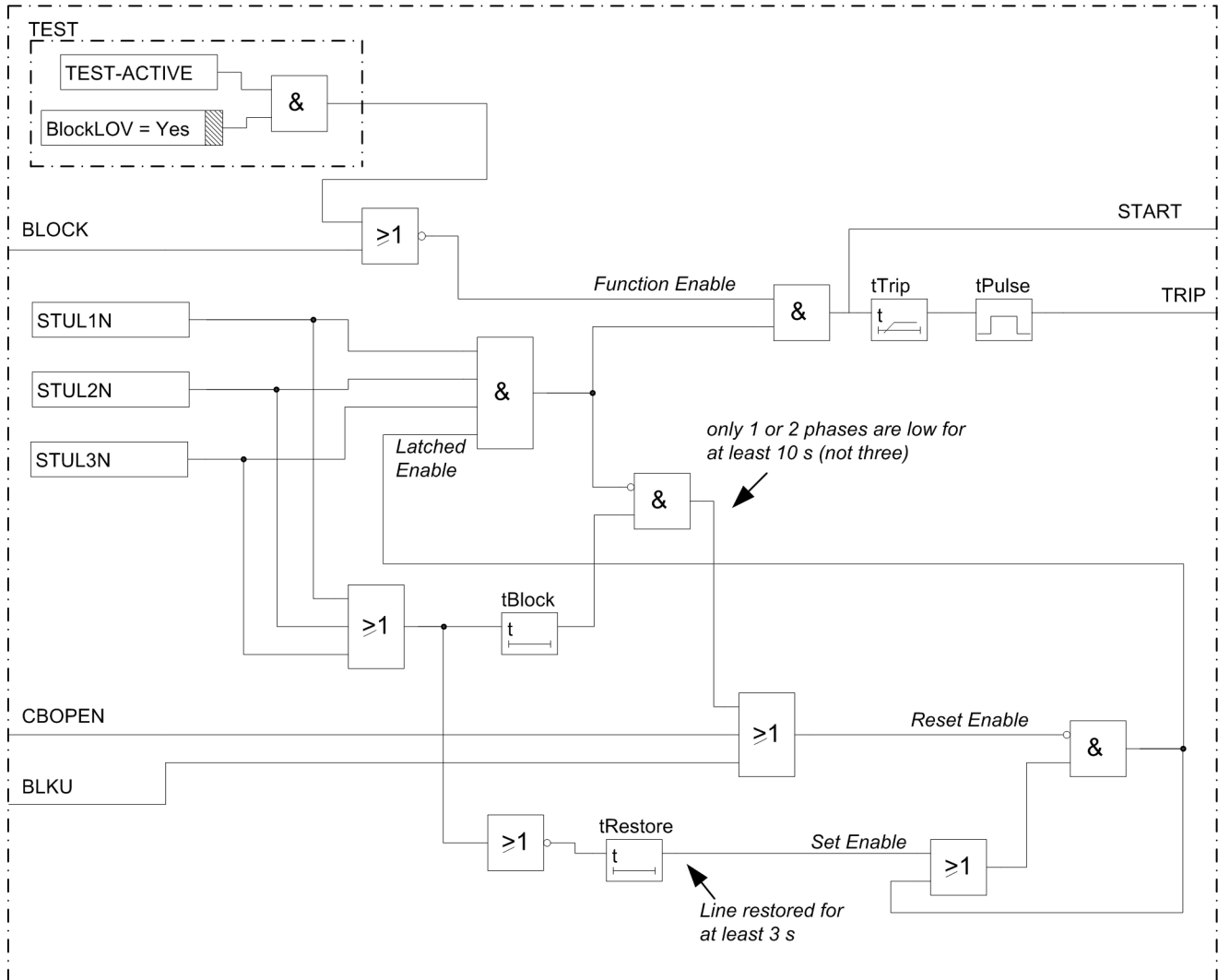

en08000011.vsd

Figure 77: Simplified diagram of Loss of voltage check LOVPTUV

7.4.7 Technical data

Table 134: LOVPTUV technical data

Function	Range or value	Accuracy
Operate voltage	(0–100)% of UBase	± 0.5% of U _r
Reset ratio	<105%	-
Pulse timer	(0.050–60.000) s	± 0.5% ± 25 ms
Timers	(0.000–60.000) s	± 0.5% ± 25 ms

Section 8 Frequency protection

8.1 Underfrequency protection SAPTUF

8.1.1 Identification

Function description	IEC 61850 identification	IEC 60617 identification	ANSI/IEEE C37.2 device number
Underfrequency protection	SAPTUF	<div style="border: 1px solid black; padding: 5px; display: inline-block;"> $f <$ </div>	81

8.1.2 Functionality

Underfrequency occurs as a result of a lack of sufficient generation in the network.

Underfrequency protection SAPTUF measures frequency with high accuracy, and is used for load shedding systems, remedial action schemes, gas turbine startup and so on. Separate definite time delays are provided for operate and restore.

SAPTUF is provided with undervoltage blocking.

8.1.3 Function block

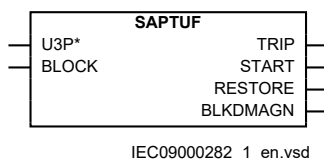

Figure 78: SAPTUF function block

8.1.4 Signals

Table 135: SAPTUF Input signals

Name	Type	Default	Description
U3P	GROUP SIGNAL	-	Three phase group signal for voltage inputs
BLOCK	BOOLEAN	0	Block of function

Table 136: SAPTUF Output signals

Name	Type	Description
TRIP	BOOLEAN	General trip signal
START	BOOLEAN	General start signal
RESTORE	BOOLEAN	Restore signal for load restoring purposes
BLKDMAGN	BOOLEAN	Measurement blocked due to low voltage amplitude

8.1.5 Settings

Table 137: SAPTUF Group settings (basic)

Name	Values (Range)	Unit	Step	Default	Description
Operation	Off On	-	-	Off	Operation Off / On
StartFrequency	35.00 - 75.00	Hz	0.01	48.80	Frequency set value
tDelay	0.000 - 60.000	s	0.001	0.200	Operate time delay
tRestore	0.000 - 60.000	s	0.001	0.000	Restore time delay
RestoreFreq	45.00 - 65.00	Hz	0.01	49.90	Restore frequency if frequency is above frequency value

8.1.6 Monitored data

Table 138: SAPTUF Monitored data

Name	Type	Values (Range)	Unit	Description
FREQ	REAL	-	Hz	Measured frequency

8.1.7 Operation principle

The underfrequency protection (SAPTUF) function is used to detect low power system frequency. If the frequency remains below the set value for a time period greater than the set time delay the TRIP signal is issued. To avoid an unwanted trip due to uncertain frequency measurement at low voltage magnitude, a voltage controlled blocking of the function is available from the preprocessing function, that is, if the voltage is lower than the set blocking voltage in the preprocessing function, the function is blocked and no START or TRIP signal is issued.

8.1.7.1 Measurement principle

The frequency measuring element continuously measures the frequency of the positive sequence voltage and compares it to the setting *StartFrequency*. The frequency signal is filtered to avoid transients due to switchings and faults in the power system. If the voltage magnitude decreases below the setting *MinValFreqMeas* in the SMAI preprocessing function, which is described in the Basic IED Functions chapter and is set as a percentage of a global base voltage parameter, SAPTUF gets blocked, and the output BLKDMAGN is issued. All voltage settings are made in percent of the setting of the global parameter *UBase*.

To avoid oscillations of the output START signal, a hysteresis has been included.

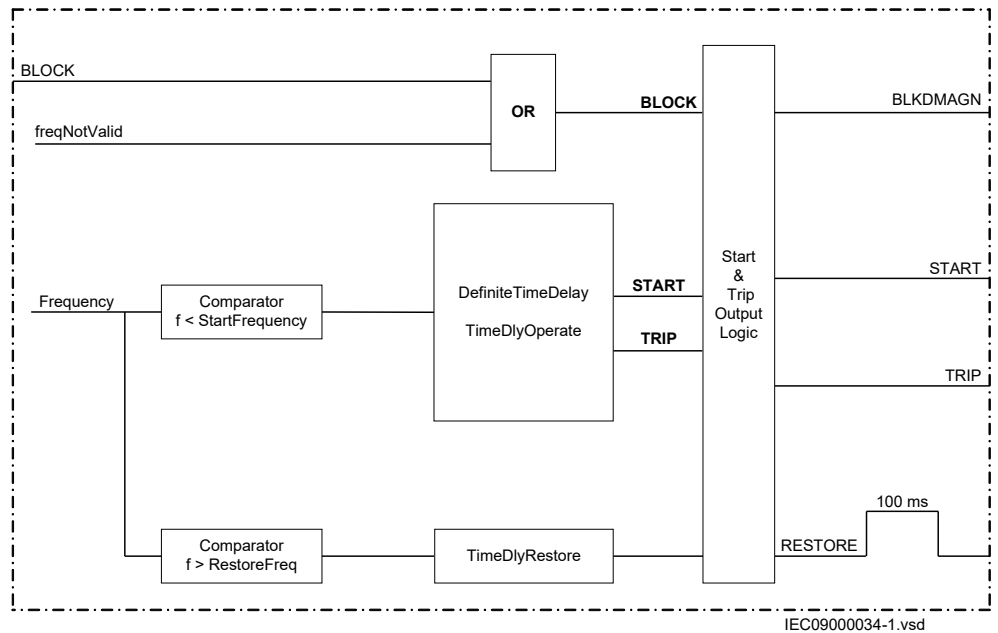

Figure 79: Simplified logic diagram for SAPTUF

8.1.7.2 Time delay

The time delay for SAPTUF is a settable definite time delay, specified by the setting $tDelay$.

Trip signal issuing requires that the under frequency condition continues for at least the user set time delay. If the START ceases during the delay time, and is not fulfilled again within a defined reset time, the START output is reset.

When the measured frequency returns to the level corresponding to the setting $RestoreFreq$, a 100ms pulse is given on the output RESTORE after a settable time delay ($tRestore$).

8.1.7.3 Blocking

It is possible to block underfrequency protection SAPTUF completely, by binary input signal:

BLOCK: blocks all outputs

If the measured voltage level decreases below the setting of $MinValFreqMeas$ in the preprocessing function both the START and the TRIP outputs are blocked.

8.1.7.4 Design

The design of underfrequency protection SAPTUF is schematically described in figure 80.

Figure 80: Simplified logic diagram for SAPTUF

8.1.8 Technical data

Table 139: SAPTUF Technical data

Function	Range or value	Accuracy
Operate value, start function	(35.00-75.00) Hz	± 2.0 mHz at symmetrical three-phase voltage
Operate value, restore frequency	(45 - 65) Hz	± 2.0 mHz
Reset ratio	<1.001	-
Operate time, start function	At 50 Hz: 200 ms typically at $f_{set} + 0.5$ Hz to $f_{set} - 0.5$ Hz At 60 Hz: 170 ms typically at $f_{set} + 0.5$ Hz to $f_{set} - 0.5$ Hz	-
Reset time, start function	At 50 Hz: 60 ms typically at $f_{set} - 0.5$ Hz to $f_{set} + 0.5$ Hz At 60 Hz: 50 ms typically at $f_{set} - 0.5$ Hz to $f_{set} + 0.5$ Hz	-
Operate time delay	(0.000-60.000)s	<250 ms
Restore time delay	(0.000-60.000)s	<150 ms

8.2 Overfrequency protection SAPTOF

8.2.1 Identification

Function description	IEC 61850 identification	IEC 60617 identification	ANSI/IEEE C37.2 device number
Overfrequency protection	SAPTOF		81

8.2.2 Functionality

Overfrequency protection function SAPTOF is applicable in all situations, where reliable detection of high fundamental power system frequency is needed.

Overfrequency occurs because of sudden load drops or shunt faults in the power network. Close to the generating plant, generator governor problems can also cause over frequency.

SAPTOF measures frequency with high accuracy, and is used mainly for generation shedding and remedial action schemes. It is also used as a frequency stage initiating load restoring. A definite time delay is provided for operate.

SAPTOF is provided with an undervoltage blocking.

8.2.3 Function block

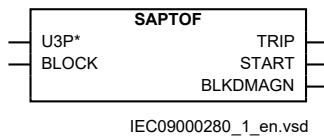

Figure 81: SAPTOF function block

8.2.4 Signals

Table 140: SAPTOF Input signals

Name	Type	Default	Description
U3P	GROUP SIGNAL	-	Three phase group signal for voltage inputs
BLOCK	BOOLEAN	0	Block of function

Table 141: SAPTOF Output signals

Name	Type	Description
TRIP	BOOLEAN	General trip signal
START	BOOLEAN	General start signal
BLKDMAGN	BOOLEAN	Measurement blocked due to low amplitude

8.2.5 Settings

Table 142: SAPTOF Group settings (basic)

Name	Values (Range)	Unit	Step	Default	Description
Operation	Off On	-	-	Off	Operation Off / On
StartFrequency	35.00 - 75.00	Hz	0.01	51.20	Frequency set value
tDelay	0.000 - 60.000	s	0.001	0.200	Operate time delay

8.2.6 Monitored data

Table 143: SAPTOF Monitored data

Name	Type	Values (Range)	Unit	Description
FREQ	REAL	-	Hz	Measured frequency

8.2.7 Operation principle

Overfrequency protection SAPTOF is used to detect high power system frequency. SAPTOF has a settable definite time delay. If the frequency remains above the set value for a time

period greater than the set time delay the TRIP signal is issued. To avoid an unwanted TRIP due to uncertain frequency measurement at low voltage magnitude, a voltage controlled blocking of the function is available from the preprocessing function, that is, if the voltage is lower than the set blocking voltage in the preprocessing function, the function is blocked and no START or TRIP signal is issued.

8.2.7.1 Measurement principle

The frequency measuring element continuously measures the frequency of the positive sequence voltage and compares it to the setting *StartFrequency*. The frequency signal is filtered to avoid transients due to switchings and faults in the power system. If the voltage magnitude decreases below the setting *MinValFreqMeas* in the SMAI preprocessing function, which is discussed in the Basic IED Functions chapter and is set as a percentage of a global base voltage parameter *UBase*, SAPTOF is blocked and the output BLKDMAGN is issued. All voltage settings are made in percent of the global parameter *UBase*. To avoid oscillations of the output START signal, a hysteresis has been included.

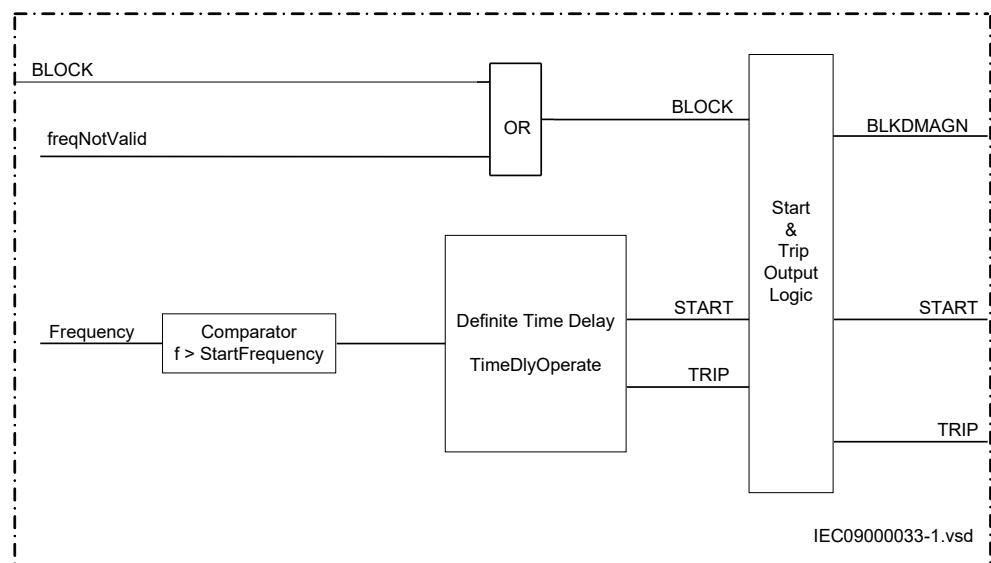

Figure 82: Schematic design of overfrequency protection SAPTOF

8.2.7.2 Time delay

The time delay for SAPTOF is a settable definite time delay, specified by the setting *tDelay*.

If the START condition frequency ceases during the delay time, and is not fulfilled again within a defined reset time, the START output is reset.

8.2.7.3 Blocking

It is possible to block Over frequency protection (SAPTOF) completely, by binary input signals or by parameter settings, where:

BLOCK: blocks all outputs

If the measured voltage level decreases below the setting of *MinValFreqMeas* in the preprocessing function both the START and the TRIP outputs are blocked.

8.2.7.4 Design

The design of overfrequency protection SAPTOF is schematically described in figure 83.

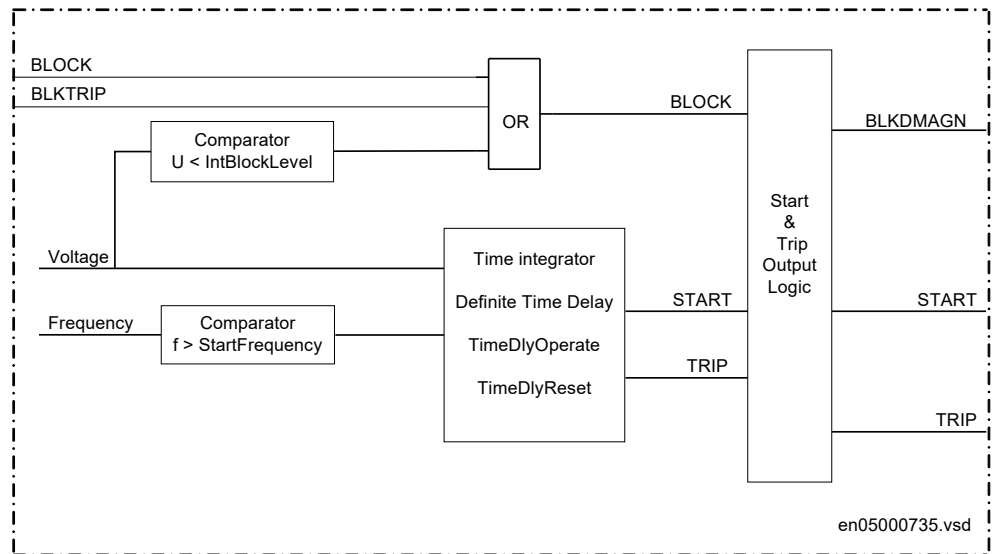

Figure 83: Schematic design of overfrequency protection SAPTOF

8.2.8 Technical data

Table 144: SAPTOF technical data

Function	Range or value	Accuracy
Operate value, start function	(35.00-75.00) Hz	± 2.0 mHz at symmetrical three-phase voltage
Reset ratio	>0.999	-
Operate time, start function	At 50 Hz: 200 ms typically at $f_{set} - 0.5$ Hz to $f_{set} + 0.5$ Hz At 60 Hz: 170 ms typically at $f_{set} - 0.5$ Hz to $f_{set} + 0.5$ Hz	-
Reset time, start function	At 50 and 60 Hz: 55 ms typically at $f_{set} + 0.5$ Hz to $f_{set} - 0.5$ Hz	-
Timer	(0.000-60.000)s	<250 ms

8.3 Rate-of-change frequency protection SAPFRC

8.3.1 Identification

Function description	IEC 61850 identification	IEC 60617 identification	ANSI/IEEE C37.2 device number
Rate-of-change frequency protection	SAPFRC	<div style="border: 1px solid black; padding: 5px; width: fit-content; margin: 0 auto;"> $df/dt \gtrless$ </div>	81

8.3.2 Functionality

The rate-of-change frequency protection function SAPFRC gives an early indication of a main disturbance in the system. SAPFRC measures frequency with high accuracy, and can be used for generation shedding, load shedding and remedial action schemes. SAPFRC can discriminate between a positive or negative change of frequency. A definite time delay is provided for operate.

SAPFRC is provided with an undervoltage blocking.

8.3.3 Function block

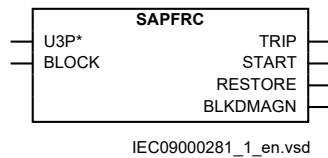

Figure 84: SAPFRC function block

8.3.4 Signals

Table 145: SAPFRC Input signals

Name	Type	Default	Description
U3P	GROUP SIGNAL	-	Three phase group signal for voltage inputs
BLOCK	BOOLEAN	0	Block of function

Table 146: SAPFRC Output signals

Name	Type	Description
TRIP	BOOLEAN	Operate/trip signal for frequency gradient
START	BOOLEAN	Start/pick-up signal for frequency gradient
RESTORE	BOOLEAN	Restore signal for load restoring purposes
BLKDMAGN	BOOLEAN	Blocking indication due to low amplitude

8.3.5 Settings

Table 147: SAPFRC Group settings (basic)

Name	Values (Range)	Unit	Step	Default	Description
Operation	Off On	-	-	Off	Operation Off / On
StartFreqGrad	-10.00 - 10.00	Hz/s	0.01	0.50	Frequency gradient start value, the sign defines direction
tTrip	0.000 - 60.000	s	0.001	0.200	Operate time delay in positive / negative frequency gradient mode
RestoreFreq	45.00 - 65.00	Hz	0.01	49.90	Restore is enabled if frequency is above set frequency value
tRestore	0.000 - 60.000	s	0.001	0.000	Restore time delay

8.3.6 Operation principle

Rate-of-change frequency protection SAPFRC is used to detect fast power system frequency changes at an early stage. It has a settable definite time delay. To avoid an unwanted trip due to uncertain frequency measurement at low voltage magnitude, a voltage controlled blocking of the function is available from the preprocessing function that is, if the voltage is lower than the set blocking voltage in the preprocessing function, the function is blocked and no START or TRIP signal is issued. If the frequency recovers, after a frequency decrease, a restore signal is issued.

8.3.6.1 Measurement principle

The rate-of-change of the fundamental frequency of the selected voltage is measured continuously, and compared with the set value (*StartFreqGrad*). If the voltage magnitude decreases below the setting *MinValFreqMeas* in the preprocessing function, which is set as a percentage of a global base voltage parameter, SAPFRC is blocked and the output BLKDMAGN is issued. The sign of the setting *StartFreqGrad*, controls if SAPFRC reacts on a positive or on a negative change in frequency. If SAPFRC is used for decreasing frequency that is, the setting *StartFreqGrad* has been given a negative value, and a trip signal has been issued, a 100 ms pulse is issued on the RESTORE output, when the frequency recovers to a value higher than the setting *RestoreFreq*. A positive setting of *StartFreqGrad*, sets SAPFRC to START and TRIP for frequency increases.

To avoid oscillations of the output START signal, a hysteresis has been included.

8.3.6.2 Time delay

SAPFRC has a settable definite time delay, *tTrip*.

Trip signal issuing requires that SAPFRC condition continues for at least the user set time delay, *tTrip*. If the START condition, ceases during the delay time and is not fulfilled again within a defined reset time, the START output is reset after the reset time has elapsed.

After an issue of the TRIP output signal, the RESTORE output of SAPFRC is set after a time delay (*tRestore*), when the measured frequency has returned to the level corresponding to *RestoreFreq*. If *tRestore* is set to 0.000 s the restore functionality is disabled, and no output will be given. The restore functionality is only active for lowering frequency conditions and the restore sequence is disabled if a new negative frequency gradient is detected during the restore period.

8.3.6.3 Design

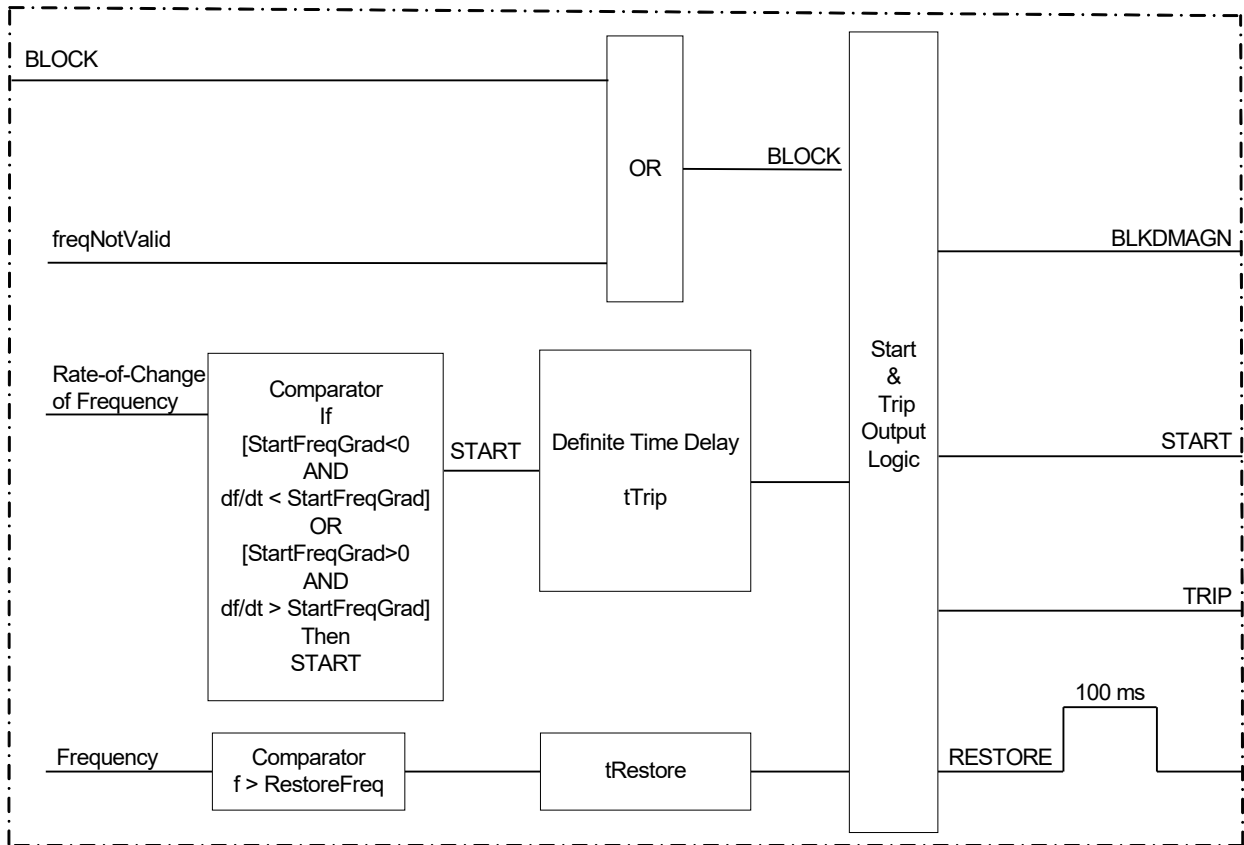

IEC08000009_en_1.vsd

Figure 85: Schematic design of Rate-of-change frequency protection SAPFRC

8.3.7 Technical data

Table 148: SAPFRC technical data

Function	Range or value	Accuracy
Operate value, start function	(-10.00-10.00) Hz/s	± 10.0 mHz/s
Operate value, restore enable frequency	(45.00 - 65.00) Hz	± 2.0 mHz
Timers	(0.000 - 60.000) s	<130 ms
Operate time, start function	At 50 Hz: 100 ms typically At 60 Hz: 80 ms typically	-

Section 9 Secondary system supervision

9.1 Current circuit supervision CCSRDIF

9.1.1 Identification

Function description	IEC 61850 identification	IEC 60617 identification	ANSI/IEEE C37.2 device number
Current circuit supervision	CCSRDIF	-	87

9.1.2 Functionality

Open or short circuited current transformer cores can cause unwanted operation of many protection functions such as differential, earth-fault current and negative-sequence current functions.

It must be remembered that a blocking of protection functions at an occurrence of open CT circuit will mean that the situation will remain and extremely high voltages will stress the secondary circuit.

Current circuit supervision (CCSRDIF) compares the residual current from a three phase set of current transformer cores with the neutral point current on a separate input taken from another set of cores on the current transformer.

A detection of a difference indicates a fault in the circuit and is used as alarm or to block protection functions expected to give inadvertent tripping.

9.1.3 Function block

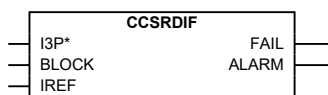

IEC08000055-1-en.vsd

Figure 86: CCSRDIF function block

9.1.4 Signals

Table 149: CCSRDIF Input signals

Name	Type	Default	Description
I3P	GROUP SIGNAL	-	Three phase group signal for current inputs
IREF	GROUP SIGNAL	-	Group signal for current reference
BLOCK	BOOLEAN	0	Block of function

Table 150: CCSRDIF Output signals

Name	Type	Description
FAIL	BOOLEAN	Detection of current circuit failure
ALARM	BOOLEAN	Alarm for current circuit failure

9.1.5 Settings

Table 151: CCSRDIF Group settings (basic)

Name	Values (Range)	Unit	Step	Default	Description
Operation	Off On	-	-	Off	Operation Off / On
IMinOp	5 - 200	%IB	1	20	Minimum operate current differential level in % of IBase

Table 152: CCSRDIF Group settings (advanced)

Name	Values (Range)	Unit	Step	Default	Description
Ip>Block	5 - 500	%IB	1	150	Block of the function at high phase current, in % of IBase

Table 153: CCSRDIF Non group settings (basic)

Name	Values (Range)	Unit	Step	Default	Description
GlobalBaseSel	1 - 6	-	1	1	Selection of one of the Global Base Value groups

9.1.6 Operation principle

Current circuit supervision CCSRDIF compares the absolute value of the vectorial sum of the three phase currents $|\Sigma I_{\text{phase}}|$ and the numerical value of the residual current $|I_{\text{ref}}|$ from another current transformer set, see figure 87.

The FAIL output will be set to a logical one when the following criteria are fulfilled:

- The numerical value of the difference $|\Sigma I_{\text{phase}}| - |I_{\text{ref}}|$ is higher than 80% of the numerical value of the sum $|\Sigma I_{\text{phase}}| + |I_{\text{ref}}|$.
- The numerical value of the current $|\Sigma I_{\text{phase}}| - |I_{\text{ref}}|$ is equal to or higher than the set operate value *IMinOp*.
- No phase current has exceeded *Ip>Block* during the last 10 ms.
- CCSRDIF is enabled by setting *Operation = On*.

The FAIL output remains activated 100 ms after the AND-gate resets when being activated for more than 20 ms. If the FAIL lasts for more than 150 ms an ALARM will be issued. In this case the FAIL and ALARM will remain activated 1 s after the AND-gate resets. This prevents unwanted resetting of the blocking function when phase current supervision element(s) operate, for example, during a fault.

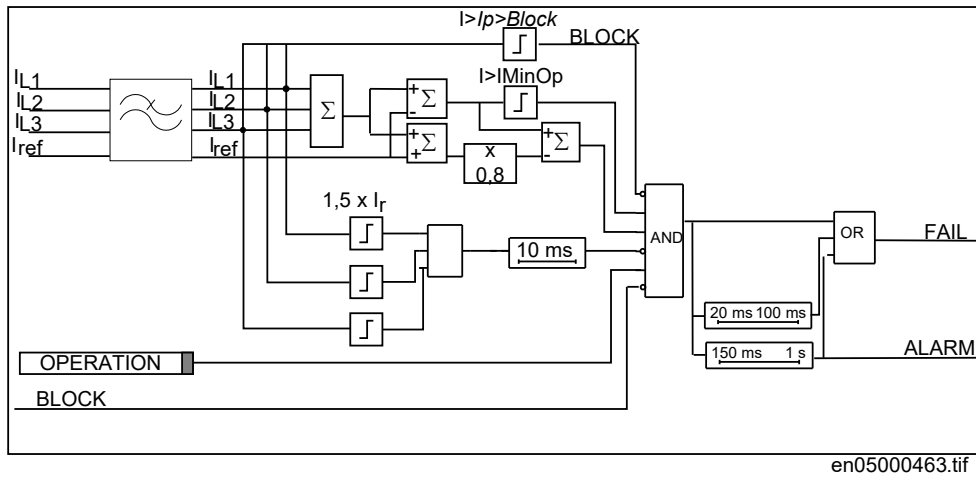

Figure 87: Simplified logic diagram for Current circuit supervision CCSRDIF
The operate characteristic is percentage restrained, see figure 88.

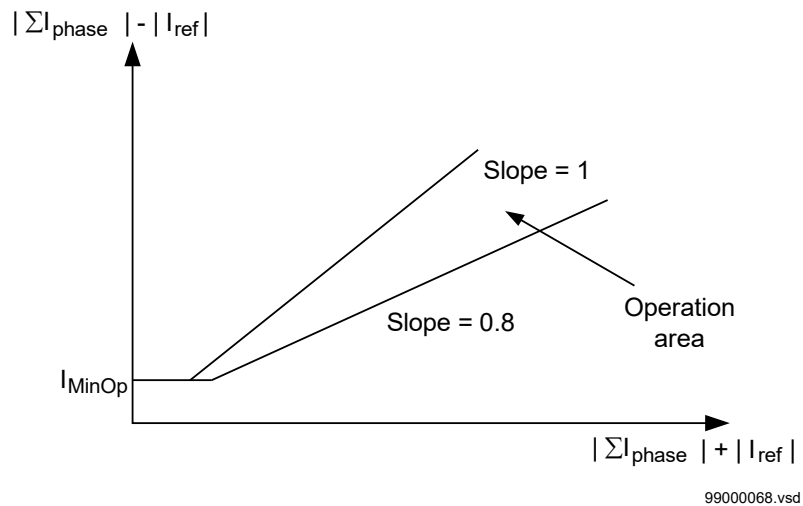

Figure 88: Operate characteristics



Due to the formulas for the axis compared, $|\Sigma I_{\text{phase}}| - |I_{\text{ref}}|$ and $|\Sigma I_{\text{phase}}| + |I_{\text{ref}}|$ respectively, the slope can not be above 2.

9.1.7 Technical data

Table 154: CCSRDIF technical data

Function	Range or value	Accuracy
Operate current	(5-200)% of I_r	$\pm 10.0\%$ of I_r at $I \leq I_r$ $\pm 10.0\%$ of I at $I > I_r$
Block current	(5-500)% of I_r	$\pm 5.0\%$ of I_r at $I \leq I_r$ $\pm 5.0\%$ of I at $I > I_r$

9.2 Fuse failure supervision SDDRFUF

9.2.1 Identification

Function description	IEC 61850 identification	IEC 60617 identification	ANSI/IEEE C37.2 device number
Fuse failure supervision	SDDRFUF	-	-

9.2.2 Functionality

The aim of the fuse failure supervision function SDDRFUF is to block voltage measuring functions at failures in the secondary circuits between the voltage transformer and the IED in order to avoid inadvertent operations that otherwise might occur.

The fuse failure supervision function basically has three different detection methods, negative sequence and zero sequence based detection and an additional delta voltage and delta current detection.

The negative sequence detection is recommended for IEDs used in isolated or high-impedance earthed networks. It is based on the negative-sequence measuring quantities, a high value of negative sequence voltage $3U_2$ without the presence of the negative-sequence current $3I_2$.

The zero sequence detection is recommended for IEDs used in directly or low impedance earthed networks. It is based on the zero sequence measuring quantities, a high value of zero sequence voltage $3U_0$ without the presence of the zero sequence current $3I_0$.

For better adaptation to system requirements, an operation mode setting has been introduced which makes it possible to select the operating conditions for negative sequence and zero sequence based function. The selection of different operation modes makes it possible to choose different interaction possibilities between the negative sequence and zero sequence based detection.

A criterion based on delta current and delta voltage measurements can be added to the fuse failure supervision function in order to detect a three phase fuse failure, which in practice is more associated with voltage transformer switching during station operations.

9.2.3 Function block

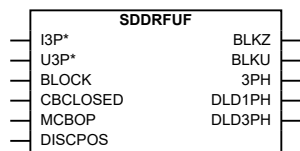

Figure 89: SDDRFUF function block

9.2.4 Signals

Table 155: SDDRFUF Input signals

Name	Type	Default	Description
I3P	GROUP SIGNAL	-	Three phase group signal for current inputs
U3P	GROUP SIGNAL	-	Three phase group signal for voltage inputs
BLOCK	BOOLEAN	0	Block of function
CBCLOSED	BOOLEAN	0	Active when circuit breaker is closed
MCBOP	BOOLEAN	0	Active when external MCB opens protected voltage circuit
DISCPOS	BOOLEAN	0	Active when line disconnecter is open

Table 156: SDDRFUF Output signals

Name	Type	Description
BLKZ	BOOLEAN	Start of current and voltage controlled function
BLKU	BOOLEAN	General start of function
3PH	BOOLEAN	Three-phase start of function
DLD1PH	BOOLEAN	Dead line condition in at least one phase
DLD3PH	BOOLEAN	Dead line condition in all three phases

9.2.5 Settings

Table 157: SDDRFUF Group settings (basic)

Name	Values (Range)	Unit	Step	Default	Description
Operation	Off On	-	-	On	Operation Off / On
OpMode	Off UNsINs UZsIZs UZsIZs OR UNsINs UZsIZs AND UNsINs OptimZsNs	-	-	UZsIZs	Operating mode selection
3U0>	1 - 100	%UB	1	30	Operate level of residual overvoltage element in % of UBase
3I0<	1 - 100	%IB	1	10	Operate level of residual undercurrent element in % of IBase
3U2>	1 - 100	%UB	1	30	Operate level of neg seq overvoltage element in % of UBase
3I2<	1 - 100	%IB	1	10	Operate level of neg seq undercurrent element in % of IBase
OpDUDI	Off On	-	-	Off	Operation of change based function Off/On
DU>	1 - 100	%UB	1	60	Operate level of change in phase voltage in % of UBase

Table continues on next page

Name	Values (Range)	Unit	Step	Default	Description
DI<	1 - 100	%IB	1	15	Operate level of change in phase current in % of IBase
UPh>	1 - 100	%UB	1	70	Operate level of phase voltage in % of UBase
IPh>	1 - 100	%IB	1	10	Operate level of phase current in % of IBase
SealIn	Off On	-	-	On	Seal in functionality Off/On
USEalIn<	1 - 100	%UB	1	70	Operate level of seal-in phase voltage in % of UBase
IDLD<	1 - 100	%IB	1	5	Operate level for open phase current detection in % of IBase
UDLD<	1 - 100	%UB	1	60	Operate level for open phase voltage detection in % of UBase

Table 158: SDDRFUF Non group settings (basic)

Name	Values (Range)	Unit	Step	Default	Description
GlobalBaseSel	1 - 6	-	1	1	Selection of one of the Global Base Value groups

9.2.6 Monitored data

Table 159: SDDRFUF Monitored data

Name	Type	Values (Range)	Unit	Description
3I0	REAL	-	A	Magnitude of zero sequence current
3I2	REAL	-	A	Magnitude of negative sequence current
3U0	REAL	-	kV	Magnitude of zero sequence voltage
3U2	REAL	-	kV	Magnitude of negative sequence voltage

9.2.7 Operation principle

9.2.7.1 Zero and negative sequence detection

The zero and negative sequence function continuously measures the currents and voltages in all three phases and calculates: (see figure 90)

- the zero-sequence voltage $3U_0$
- the zero-sequence current $3I_0$
- the negative sequence current $3I_2$
- the negative sequence voltage $3U_2$

The measured signals are compared with their respective set values $3U0<$ and $3I0>$, $3U2<$ and $3I2>$.

The function enable the internal signal FuseFailDetZeroSeq if the measured zero-sequence voltage is higher than the set value $3U_0>$ and the measured zero-sequence current is below the set value $3I_0<$.

The function enable the internal signal FuseFailDetNegSeq if the measured negative sequence voltage is higher than the set value $3U_2>$ and the measured negative sequence current is below the set value $3I_2<$.

A drop off delay of 100 ms for the measured zero-sequence and negative sequence current will prevent a false fuse failure detection at un-equal breaker opening at the two line ends.

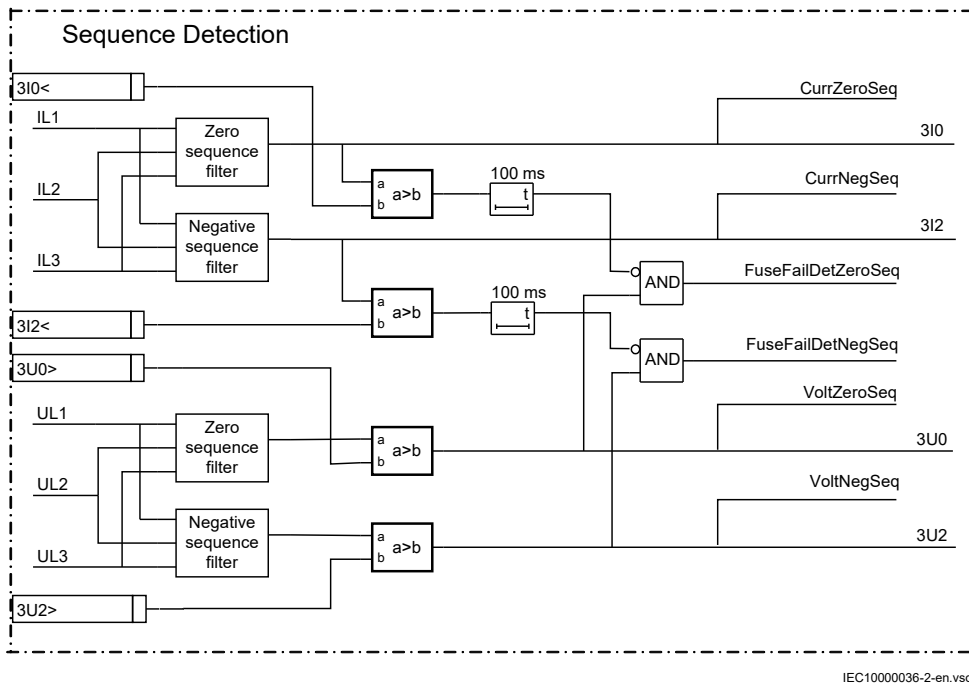

Figure 90: Simplified logic diagram for sequence detection part

The calculated values $3U_0$, $3I_0$, $3I_2$ and $3U_2$ are available as service values on local HMI and monitoring tool in PCM600.

9.2.7.2 Delta current and delta voltage detection

A simplified diagram for the functionality is found in figure 91. The calculation of the change is based on vector change which means that it detects both amplitude and phase angle changes. The calculated delta quantities are compared with their respective set values $DI<$ and $DU>$ and the algorithm, detects a fuse failure if a sufficient change in voltage without a sufficient change in current is detected in each phase separately. The following quantities are calculated in all three phases:

- The change in voltage DU
- The change in current DI

The internal FuseFailDetDUDI signal is activated if the following conditions are fulfilled for a phase:

- The magnitude of the phase-earth voltage has been above $UPh>$ for more than 1.5 cycle
- The magnitude of DU is higher than the setting $DU>$
- The magnitude of DI is below the setting $DI>$

and at least one of the following conditions are fulfilled:

- The magnitude of the phase current in the same phase is higher than the setting $I_{Ph>}$
- The circuit breaker is closed (CBCLOSED = True)

The first criterion means that detection of failure in one phase together with a current in the same phase greater than $50P$ will set the output. The measured phase current is used to reduce the risk of false fuse failure detection. If the current on the protected line is low, a voltage drop in the system (not caused by fuse failure) is not necessarily followed by current change and a false fuse failure might occur.

The second criterion requires that the delta condition shall be fulfilled in any phase while the circuit breaker is closed. A fault occurs with an open circuit breaker at one end and closed at the other end, could lead to wrong start of the fuse failure function at the end with the open breaker. If this is considered to be a disadvantage, connect the CBCLOSED input to FALSE. In this way only the first criterion can activate the delta function.

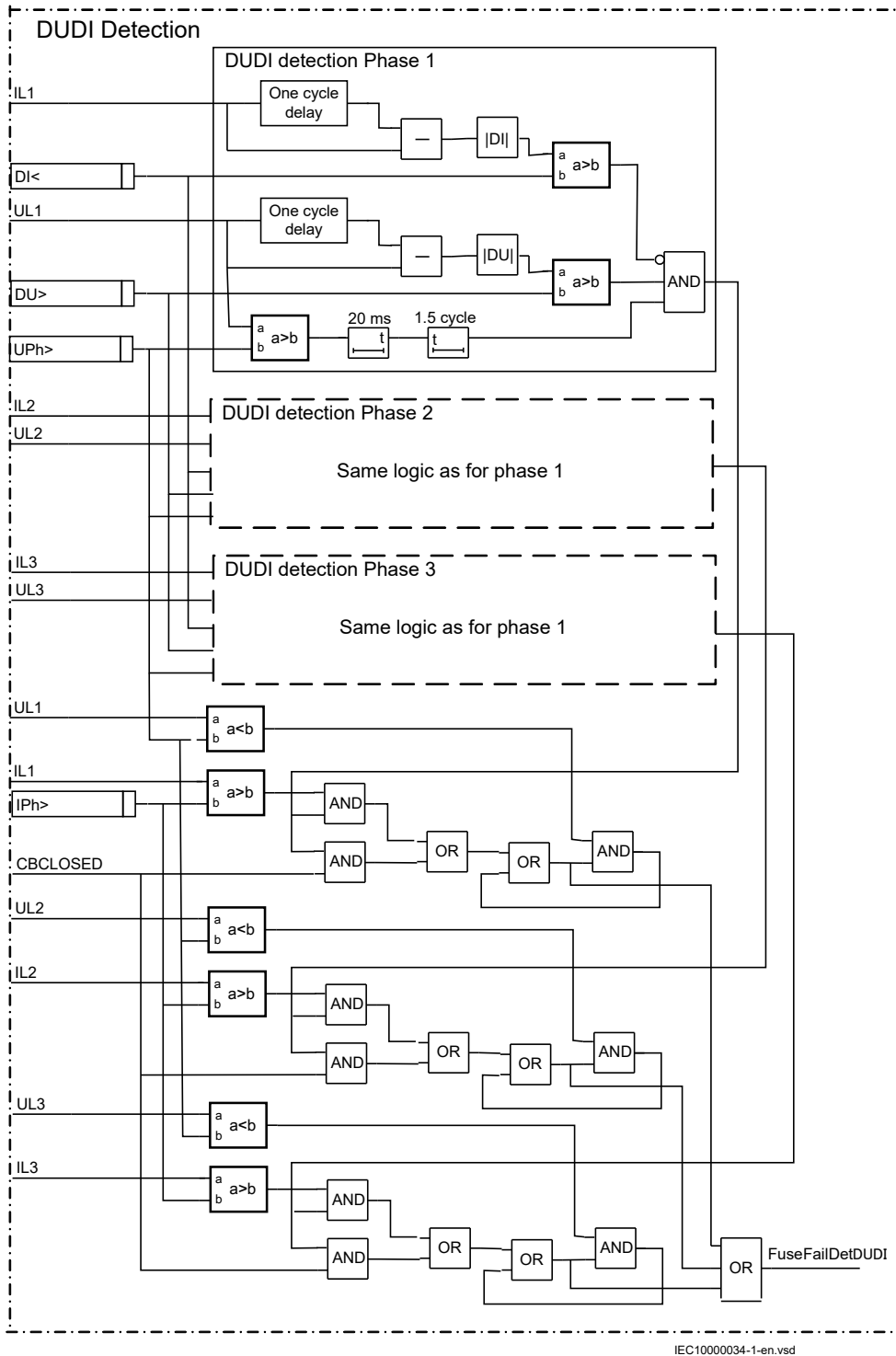

IEC10000034-1-en.vsd

Figure 91: Simplified logic diagram for DU/DI detection part

9.2.7.3 Dead line detection

A simplified diagram for the functionality is found in figure 92. A dead phase condition is indicated if both the voltage and the current in one phase is below their respective setting values $UDLD<$ and $IDLD<$. If at least one phase is considered to be dead the output $DLD1PH$ and the internal signal $DeadLineDet1Ph$ is activated. If all three phases are considered to be dead the output $DLD3PH$ is activated

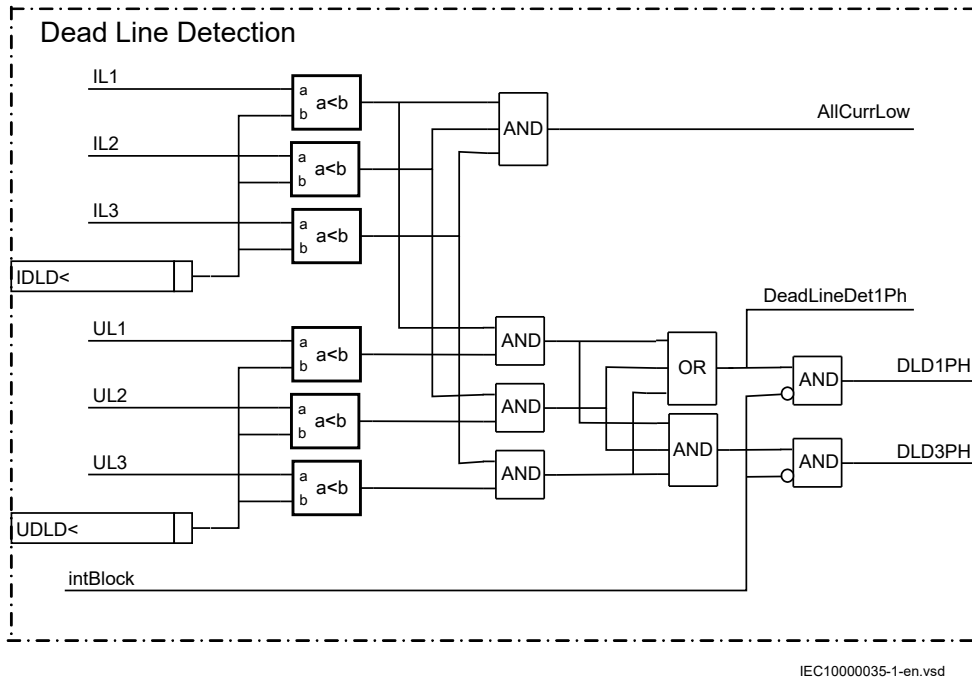

Figure 92: Simplified logic diagram for Dead Line detection part

9.2.7.4 Main logic

A simplified diagram for the functionality is found in figure 93. The fuse failure supervision function (SDDRFUF) can be switched on or off by the setting parameter *Operation* to *On* or *Off*.

For increased flexibility and adaptation to system requirements an operation mode selector, *OpMode*, has been introduced to make it possible to select different operating modes for the negative and zero sequence based algorithms. The different operation modes are:

- *Off*. The negative and zero sequence function is switched off.
- *UNsINs*. Negative sequence is selected.
- *UZsIZs*. Zero sequence is selected.
- *UZsIZs OR UNsINs*. Both negative and zero sequence is activated and working in parallel (OR-condition for operation).
- *UZsIZs AND UNsINs*. Both negative and zero sequence is activated and working in series (AND-condition for operation).
- *OptimZsNs*. Optimum of negative and zero sequence current (the function that has the highest magnitude of measured negative and zero sequence current will be activated).

The delta function can be activated by setting the parameter *OpDUDI* to *On*. When selected it operates in parallel with the sequence based algorithms.

As soon as any fuse failure situation is detected, signals FuseFailDetZeroSeq, FuseFailDetNegSeq or FuseFailDetDUDI, and the specific functionality is released, the function will activate the output signal BLKU. The output signal BLKZ will be activated as well if not the internal dead phase detection, DeadLineDet1Ph, is not activated at the same time. The output BLKU can be used for blocking voltage related measuring functions (under voltage protection, energizing check, and so on). For blocking of impedance protection functions, output BLKZ shall be used.

If the fuse failure situation is present for more than 5 seconds and the setting parameter *Sealln* is set to *On* it will be sealed in as long as at least one phase voltages is below the set

value $USealln<$. This will keep the BLKU and BLKZ signals activated as long as any phase voltage is below the set value $USealln<$. If all three phase voltages drop below the set value $USealln<$ and the setting parameter $Sealln$ is set to *On* the output signal 3PH will also be activated. The signals 3PH, BLKU and BLKZ signals will now be active as long as any phase voltage is below the set value $USealln<$.

If $Sealln$ is set to *On* the fuse failure condition lasting more than 5 seconds is stored in the non-volatile memory in the IED. At start-up of the IED (due to auxiliary power interruption or restart due to configuration change) it uses the stored value in its non-volatile memory and re-establishes the conditions that were present before the shut down. All phase voltages must be restored above $USealln<$ before fuse failure is de-activated and resets the signals BLKU, BLKZ and 3PH.

The output signal BLKU will also be active if all phase voltages have been above the setting $USealln<$ for more than 60 seconds, the zero or negative sequence voltage has been above the set value $3U0>$ and $3U2>$ for more than 5 seconds, all phase currents are below the setting $IDLD<$ (operate level for dead line detection) and the circuit breaker is closed (input CBCLOSED is activated).

If a MCB is used then the input signal MCBOP is to be connected via a terminal binary input to the N.C. auxiliary contact of the miniature circuit breaker protecting the VT secondary circuit. The MCBOP signal sets the output signals BLKU and BLKZ in order to block all the voltage related functions when the MCB is open independent of the setting of $OpMode$ or $OpDUDI$. An additional drop-out timer of 150 ms prolongs the presence of MCBOP signal to prevent the unwanted operation of voltage dependent function due to non simultaneous closing of the main contacts of the miniature circuit breaker.

The input signal DISCPOS is supposed to be connected via a terminal binary input to the N.C. auxiliary contact of the line disconnector. The DISCPOS signal sets the output signal BLKU in order to block the voltage related functions when the line disconnector is open. The impedance protection function does not have to be affected since there will be no line currents that can cause malfunction of the distance protection.

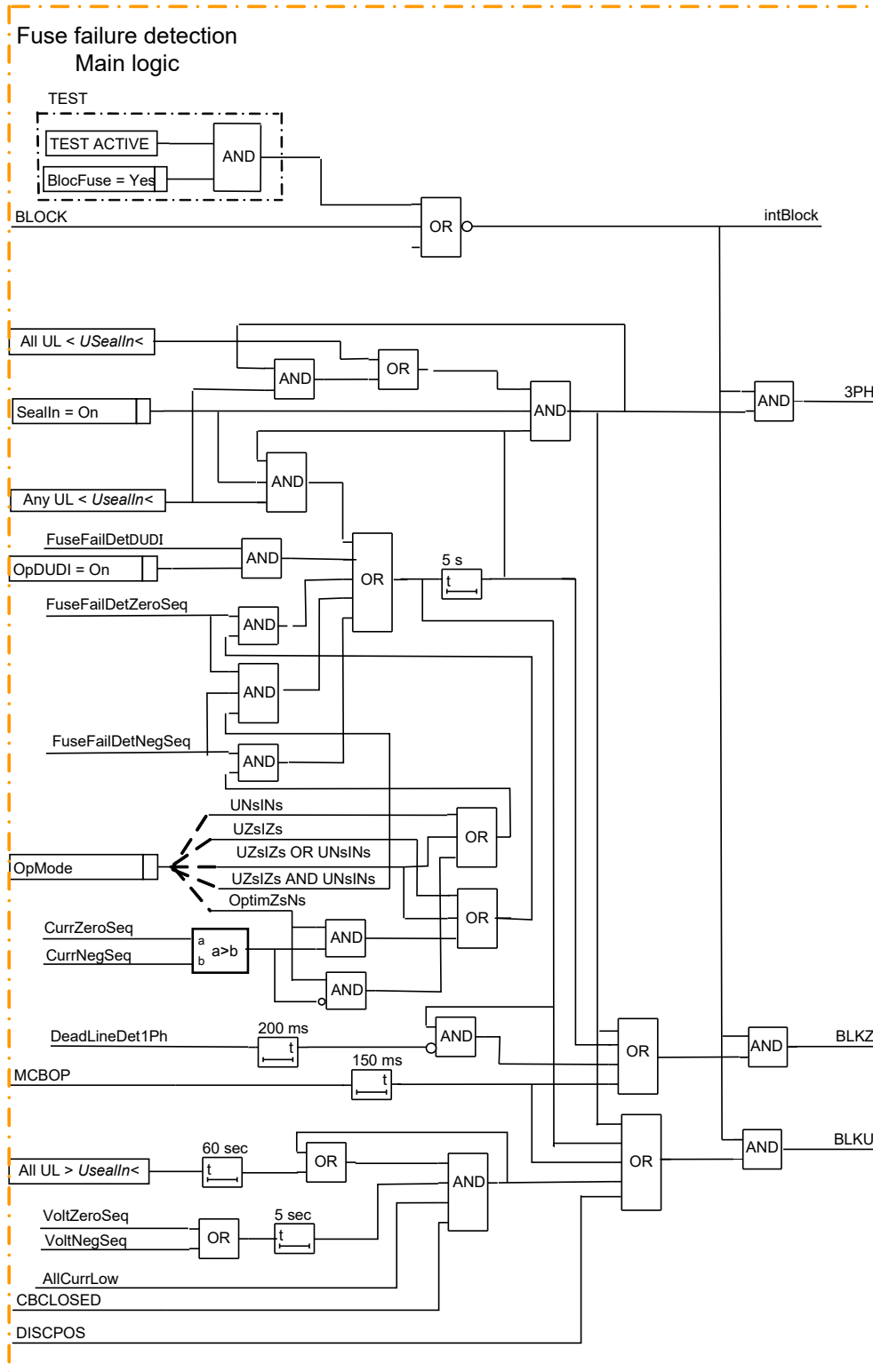

IEC1000041-1-en.vsd

Figure 93: Simplified logic diagram for fuse failure supervision function, Main logic

9.2.8 Technical data

Table 160: SDDRFUF technical data

Function	Range or value	Accuracy
Operate voltage, zero sequence	(1-100)% of UBase	± 1.0% of U_r
Operate current, zero sequence	(1-100)% of IBase	± 1.0% of I_r
Operate voltage, negative sequence	(1-100)% of UBase	± 0.5% of U_r
Operate current, negative sequence	(1-100)% of IBase	± 1.0% of I_r
Operate voltage change level	(1-100)% of UBase	± 5.0% of U_r
Operate current change level	(1-100)% of IBase	± 5.0% of I_r
Operate phase voltage	(1-100)% of UBase	± 0.5% of U_r
Operate phase current	(1-100)% of IBase	± 1.0% of I_r
Operate phase dead line voltage	(1-100)% of UBase	± 0.5% of U_r
Operate phase dead line current	(1-100)% of IBase	± 1.0% of I_r

9.3 Breaker close/trip circuit monitoring TCSSCBR

9.3.1 Identification

Function description	IEC 61850 identification	IEC 60617 identification	ANSI/IEEE C37.2 device number
Breaker close/trip circuit monitoring	TCSSCBR	-	-

9.3.2 Functionality

The trip circuit supervision function TCSSCBR is designed to supervise the control circuit of the circuit breaker. The trip circuit supervision generates a current of approximately 1 mA through the supervised control circuit. The validity supervision of a control circuit is provided for power output contacts T1, T2 and T3.

The trip circuit supervision operates after a settable definite operating time and resets after a settable definite time when the fault disappears.

9.3.3 Function block



Figure 94: Function block

9.3.4 Signals

Table 161: TCSSCBR Input signals

Name	Type	Default	Description
TCS_STATE	BOOLEAN	0	Trip circuit fail indication from I/O-card
BLOCK	BOOLEAN	0	Block of function

Table 162: TCSSCBR Output signals

Name	Type	Description
ALARM	BOOLEAN	Trip circuit fault indication

9.3.5 Settings

Table 163: TCSSCBR Non group settings (basic)

Name	Values (Range)	Unit	Step	Default	Description
Operation	Off On	-	-	On	Operation Off/On
tDelay	0.020 - 300.000	s	0.001	3.000	Operate time delay

9.3.6 Operation principle

The function can be enabled and disabled with the *Operation* setting. The corresponding parameter values are "On" and "Off".

The operation of trip circuit supervision can be described by using a module diagram. All the modules in the diagram are explained in the next sections.

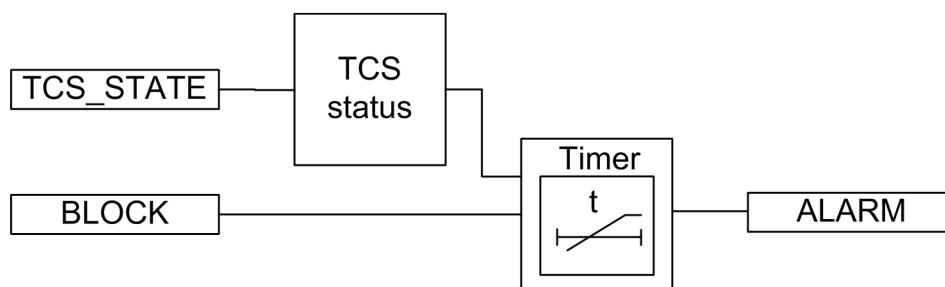

Figure 95: Functional module diagram



Trip circuit supervision generates a current of approximately 1.0 mA through the supervised circuit. It must be ensured that this current will not cause a latch up of the controlled object.



To protect the trip circuit supervision circuits in the IED, the output contacts are provided with parallel transient voltage suppressors. The breakdown voltage of these suppressors is 400 +/- 20 V DC.

Timer

Once activated, the timer runs until the set value t_{Delay} is elapsed. The time characteristic is according to DT. When the operation timer has reached the maximum time value, the `ALARM` output is activated. If a drop-off situation occurs during the operate time up counting, the reset timer is activated.

The binary input `BLOCK` can be used to block the function. The activation of the `BLOCK` input deactivates the `ALARM` output and resets the internal timer.

9.3.7 Technical data

Table 164: TCSSCBR Technical data

Function	Range or value	Accuracy
Operate time delay	(0.020 - 300.000) s	± 0,5% ± 110 ms

Section 10 Control

10.1 Synchrocheck, energizing check, and synchronizing SESRSYN

10.1.1 Identification

Function description	IEC 61850 identification	IEC 60617 identification	ANSI/IEEE C37.2 device number
Synchrocheck, energizing check, and synchronizing	SESRSYN	<div style="border: 1px solid black; padding: 5px; display: inline-block;">sc/vc</div>	25

10.1.2 Functionality

The Synchronizing function allows closing of asynchronous networks at the correct moment including the breaker closing time, which improves the network stability.

Synchrocheck, energizing check, and synchronizing SESRSYN function checks that the voltages on both sides of the circuit breaker are in synchronism, or with at least one side dead to ensure that closing can be done safely.

SESRSYN function includes a built-in voltage selection scheme for double bus and 1½ breaker or ring busbar arrangements.

Manual closing as well as automatic reclosing can be checked by the function and can have different settings.

For systems, which are running asynchronous, a synchronizing function is provided. The main purpose of the synchronizing function is to provide controlled closing of circuit breakers when two asynchronous systems are going to be connected. The synchronizing function evaluates voltage difference, phase angle difference, slip frequency and frequency rate of change before issuing a controlled closing of the circuit breaker. Breaker closing time is a parameter setting.

10.1.3 Function block

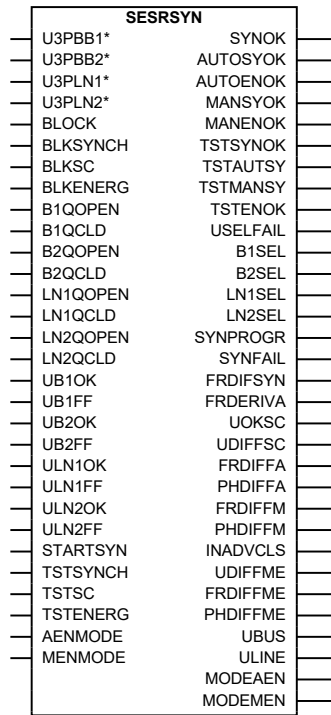

IEC08000219_3_en.vsd

Figure 96: SESRSYN function block

10.1.4 Signals

Table 165: SESRSYN Input signals

Name	Type	Default	Description
U3PBB1	GROUP SIGNAL	-	Group signal for phase to earth voltage input L1, busbar 1
U3PBB2	GROUP SIGNAL	-	Group signal for phase to earth voltage input L1, busbar 2
U3PLN1	GROUP SIGNAL	-	Group signal for phase to earth voltage input L1, line 1
U3PLN2	GROUP SIGNAL	-	Group signal for phase to earth voltage input L1, line 2
BLOCK	BOOLEAN	0	General block
BLKSYNCH	BOOLEAN	0	Block synchronizing
BLKSC	BOOLEAN	0	Block synchro check
BLKENERG	BOOLEAN	0	Block energizing check
B1QOPEN	BOOLEAN	0	Open status for CB or disconnector connected to bus1
B1QCLD	BOOLEAN	0	Close status for CB or disconnector connected to bus1
B2QOPEN	BOOLEAN	0	Open status for CB or disconnector connected to bus2
B2QCLD	BOOLEAN	0	Close status for CB or disconnector connected to bus2
LN1QOPEN	BOOLEAN	0	Open status for CB or disconnector connected to line1

Table continues on next page

Name	Type	Default	Description
LN1QCLD	BOOLEAN	0	Close status for CB or disconnecter connected to line1
LN2QOPEN	BOOLEAN	0	Open status for CB or disconnecter connected to line2
LN2QCLD	BOOLEAN	0	Close status for CB or disconnecter connected to line2
UB1OK	BOOLEAN	0	Bus1 voltage transformer OK
UB1FF	BOOLEAN	0	Bus1 voltage transformer fuse failure
UB2OK	BOOLEAN	0	Bus2 voltage transformer OK
UB2FF	BOOLEAN	0	Bus2 voltage transformer fuse failure
ULN1OK	BOOLEAN	0	Line1 voltage transformer OK
ULN1FF	BOOLEAN	0	Line1 voltage transformer fuse failure
ULN2OK	BOOLEAN	0	Line2 voltage transformer OK
ULN2FF	BOOLEAN	0	Line2 voltage transformer fuse failure
STARTSYN	BOOLEAN	0	Start synchronizing
TSTSYNCH	BOOLEAN	0	Set synchronizing in test mode
TSTSC	BOOLEAN	0	Set synchro check in test mode
TSTENERG	BOOLEAN	0	Set energizing check in test mode
AENMODE	INTEGER	0	Input for setting of automatic energizing mode
MENMODE	INTEGER	0	Input for setting of manual energizing mode

Table 166: SESRSYN Output signals

Name	Type	Description
SYNOK	BOOLEAN	Synchronizing OK output
AUTOSYOK	BOOLEAN	Auto synchro check OK
AUTOENOK	BOOLEAN	Automatic energizing check OK
MANSYOK	BOOLEAN	Manual synchro check OK
MANENOK	BOOLEAN	Manual energizing check OK
TSTSYNOK	BOOLEAN	Synchronizing OK test output
TSTAUTSY	BOOLEAN	Auto synchro check OK test output
TSTMANSY	BOOLEAN	Manual synchro check OK test output
TSTENOK	BOOLEAN	Energizing check OK test output
USELFAIL	BOOLEAN	Selected voltage transformer fuse failed
B1SEL	BOOLEAN	Bus1 selected
B2SEL	BOOLEAN	Bus2 selected
LN1SEL	BOOLEAN	Line1 selected
LN2SEL	BOOLEAN	Line2 selected
SYNPROGR	BOOLEAN	Synchronizing in progress
SYNFAIL	BOOLEAN	Synchronizing failed
FRDIFSYN	BOOLEAN	Frequency difference out of limit for synchronizing
FRDERIVA	BOOLEAN	Frequency derivative out of limit for synchronizing
UOKSC	BOOLEAN	Voltage amplitudes above set limits
UDIFFSC	BOOLEAN	Voltage difference out of limit
FRDIFFA	BOOLEAN	Frequency difference out of limit for Auto operation

Table continues on next page

Name	Type	Description
PHDIFFA	BOOLEAN	Phase angle difference out of limit for Auto operation
FRDIFFM	BOOLEAN	Frequency difference out of limit for Manual operation
PHDIFFM	BOOLEAN	Phase angle difference out of limit for Manual Operation
INADVCLS	BOOLEAN	Inadvertent circuit breaker closing
UDIFFME	REAL	Calculated difference of voltage in p.u of set voltage base value
FRDIFFME	REAL	Calculated difference of frequency
PHDIFFME	REAL	Calculated difference of phase angle
UBUS	REAL	Bus voltage
ULINE	REAL	Line voltage
MODEAEN	INTEGER	Selected mode for automatic energizing
MODEMEN	INTEGER	Selected mode for manual energizing

10.1.5 Settings

Table 167: SESRSYN Group settings (basic)

Name	Values (Range)	Unit	Step	Default	Description
Operation	Off On	-	-	Off	Operation Off / On
CBCConfig	No voltage sel. Double bus 1 1/2 bus CB 1 1/2 bus alt. CB Tie CB	-	-	No voltage sel.	Select CB configuration
URatio	0.500 - 2.000	-	0.001	1.000	Multiplication factor for minor internal adjustment of measured line voltage for synchro functions
PhaseShift	-180 - 180	Deg	1	0	Additional phase angle for selected line voltage
OperationSynch	Off On	-	-	Off	Operation for synchronizing function Off/On
FreqDiffMin	0.003 - 0.250	Hz	0.001	0.010	Minimum frequency difference limit for synchronizing
FreqDiffMax	0.050 - 0.500	Hz	0.001	0.200	Maximum frequency difference limit for synchronizing
FreqRateChange	0.000 - 0.500	Hz/s	0.001	0.300	Maximum allowed frequency rate of change
tBreaker	0.000 - 60.000	s	0.001	0.080	Closing time of the breaker
tClosePulse	0.050 - 60.000	s	0.001	0.200	Breaker closing pulse duration
tMaxSynch	0.00 - 6000.00	s	0.01	600.00	Resets synch if no close has been made before set time
tMinSynch	0.000 - 60.000	s	0.001	2.000	Minimum time to accept synchronizing conditions
OperationSC	Off On	-	-	On	Operation for synchronism check function Off/On
UDiffSC	0.02 - 0.50	pu	0.01	0.15	Voltage difference limit for synchrocheck in p.u of set voltage base value

Table continues on next page

Name	Values (Range)	Unit	Step	Default	Description
FreqDiffA	0.003 - 1.000	Hz	0.001	0.010	Frequency difference limit between bus and line Auto
FreqDiffM	0.003 - 1.000	Hz	0.001	0.010	Frequency difference limit between bus and line Manual
PhaseDiffA	5.0 - 90.0	Deg	1.0	25.0	Phase angle difference limit between bus and line Auto
PhaseDiffM	5.0 - 90.0	Deg	1.0	25.0	Phase angle difference limit between bus and line Manual
tSCA	0.000 - 60.000	s	0.001	0.100	Time delay output for synchrocheck Auto
tSCM	0.000 - 60.000	s	0.001	0.100	Time delay output for synchrocheck Manual
AutoEnerg	Off DLLB DBLL Both	-	-	DLLB	Automatic energizing check mode
ManEnerg	Off DLLB DBLL Both	-	-	Both	Manual energizing check mode
ManEnergDBDL	Off On	-	-	Off	Manual dead bus, dead line energizing
tAutoEnerg	0.000 - 60.000	s	0.001	0.100	Time delay for automatic energizing check
tManEnerg	0.000 - 60.000	s	0.001	0.100	Time delay for manual energizing check

Table 168: SESRSYN Non group settings (basic)

Name	Values (Range)	Unit	Step	Default	Description
GblBaseSelBus	1 - 6	-	1	1	Selection of one of the Global Base Value groups, Bus
GblBaseSelLine	1 - 6	-	1	1	Selection of one of the Global Base Value groups, Line
SelPhaseBus1	Phase L1 Phase L2 Phase L3 Phase L1L2 Phase L2L3 Phase L3L1 Positive sequence	-	-	Phase L1	Select phase for busbar1

Table continues on next page

Name	Values (Range)	Unit	Step	Default	Description
SelPhaseBus2	Phase L1 Phase L2 Phase L3 Phase L1L2 Phase L2L3 Phase L3L1 Positive sequence	-	-	Phase L1	Select phase for busbar2
SelPhaseLine1	Phase L1 Phase L2 Phase L3 Phase L1L2 Phase L2L3 Phase L3L1 Positive sequence	-	-	Phase L1	Select phase for line1
SelPhaseLine2	Phase L1 Phase L2 Phase L3 Phase L1L2 Phase L2L3 Phase L3L1 Positive sequence	-	-	Phase L1	Select phase for line2

10.1.6 Monitored data

Table 169: SESRSYN Monitored data

Name	Type	Values (Range)	Unit	Description
UDIFFME	REAL	-	-	Calculated difference of voltage in p.u of set voltage base value
FRDIFFME	REAL	-	Hz	Calculated difference of frequency
PHDIFFME	REAL	-	deg	Calculated difference of phase angle
UBUS	REAL	-	kV	Bus voltage
ULINE	REAL	-	kV	Line voltage

10.1.7 Operation principle

10.1.7.1 Basic functionality

The synchrocheck function measures the conditions across the circuit breaker and compares them to set limits. The output is only given when all measured quantities are simultaneously within their set limits.

The energizing check function measures the bus and line voltages and compares them to both high and low threshold detectors. The output is given only when the actual measured quantities match the set conditions.

The synchronizing function measures the conditions across the circuit breaker, and also determines the angle change occurring during the closing delay of the circuit breaker, from the measured slip frequency. The output is given only when all measured conditions are simultaneously within their set limits. The issue of the output is timed to give closure at the optimal time including the time for the circuit breaker and the closing circuit.

For single circuit breaker double bus and 1½ breaker circuit breaker arrangements, the SESRSYN function blocks have the capability to make the necessary voltage selection. For

single circuit breaker double bus arrangements, selection of the correct voltage is made using auxiliary contacts of the bus disconnectors. For 1½ breaker circuit breaker arrangements, correct voltage selection is made using auxiliary contacts of the bus/line disconnectors as well as the circuit breakers.

The internal logic for each function block as well as, the input and outputs, and the settings with default setting and setting ranges is described in this document. For application related information, please refer to the application manual.

10.1.7.2 Synchrocheck

The voltage difference, frequency difference and phase angle difference values are calculated by the SESRSYN function and are available for the synchrocheck function for evaluation. If the bus voltage is connected as phase-phase and the line voltage as phase-neutral (or the opposite), this need to be compensated. This is done by selecting the corresponding phases for the measurement in the settings for the SESRSYN function. In addition the phase angle difference has to be compensated for by the setting PhaseShift. The setting scales the line voltage and adjust the phase angle equal to the bus voltage.

When the function is set to *OperationSC = On*, the measuring will start.

The function will compare the bus and line voltage values with internally preset values that are set to be 80% of the *UBase* selected for *GlbBaseSelBus* and *GlbBaseSelLine*.

If both sides are higher than 80% of the *Ubase* values, the measured values are compared with the set values for acceptable frequency, phase angle and voltage difference: *FreqDiff*, *PhaseDiff* and *UDiff*. If a compensation factor is set due to the use of different voltages on the bus and line, the factor is deducted from the line voltage before the comparison of the phase angle values.

The frequency on both sides of the circuit breaker is also measured. The function is only released if the frequency difference is less than the fixed set value of +/-5 Hz.

Two sets of settings for frequency difference and phase angle difference are available and used for the manual closing and autoreclose functions respectively, as required.

The inputs BLOCK and BLKSC are available for total block of the complete SESRSYN function and selective block of the Synchrocheck function respectively. Input TSTSC will allow testing of the function where the fulfilled conditions are connected to a separate test output.

The outputs MANSYOK and AUTOSYOK are activated when the actual measured conditions match the set conditions for the respective output. The output signal can be delayed independently for MANSYOK and AUTOSYOK conditions.

A number of outputs are available as information about fulfilled checking conditions. UOKSC shows that the voltages are high, UDIFFFSC, FRDIFFA, FRDIFFM, PHDIFFA, PHDIFFM shows when the voltage difference, frequency difference and phase angle difference conditions are out of limits.

Output INADVCLS, inadvertent circuit breaker closing, indicate that the circuit breaker has been closed at wrong phase angle by mistake. The output is activated, if the voltage conditions are fulfilled at the same time the phase angle difference between bus and line is suddenly changed from being larger than 60 degrees to smaller than 5 degrees.

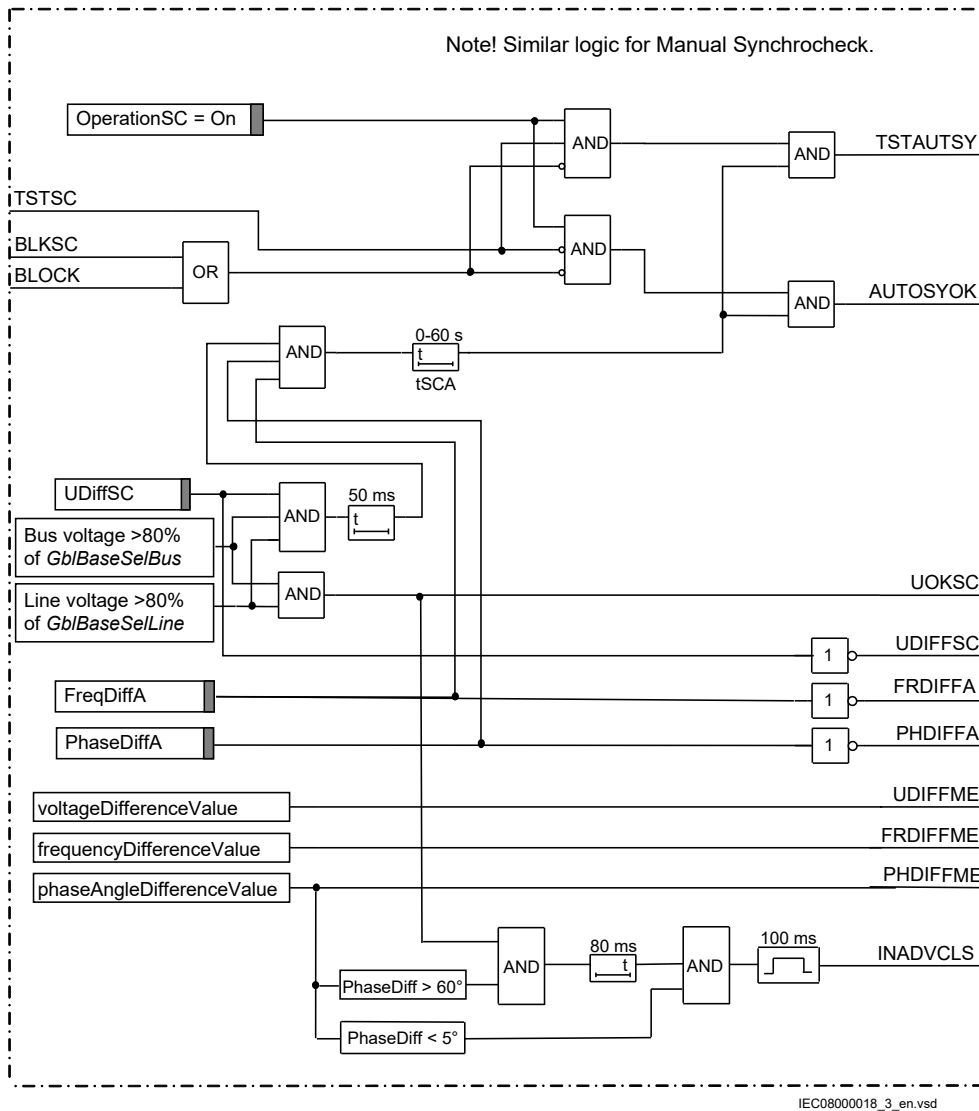

Figure 97: Simplified logic diagram for the Auto Synchrocheck function

10.1.7.3 Synchronizing

When the function is set to *OperationSynch = On* the measuring will be performed.

The function will compare the values for the bus and line voltage with internally preset values that are set to be 80% of the set *UBase* selected for *GlbBaseSelBus* and *GlbBaseSelLine*, which is a supervision that the voltages are both live. Also the voltage difference is checked to be smaller than the internally preset value 0.10, which is a p.u value of set voltage base values. If both sides are higher than the preset values and the voltage difference between bus and line is acceptable, the measured values are also compared with the set values for acceptable frequency *FreqDiffMax* and *FreqDiffMin*, rate of change of frequency *FreqRateChange* and phase angle, which has to be smaller than the internally preset value of 15 degrees.

Measured frequencies between the settings for the maximum and minimum frequency will initiate the measuring and the evaluation of the angle change to allow operation to be sent in the right moment including the set *tBreaker* time. There is a phase angle release internally to block any incorrect closing pulses. At operation the SYNOK output will be activated with a pulse *tClosePulse* and the function reset. The function will also reset if the synchronizing

conditions are not fulfilled within the set $t_{MaxSynch}$ time. This prevents that the function is, by mistake, maintained in operation for a long time, waiting for conditions to be fulfilled.

The inputs BLOCK and BLKSYNCH are available for total block of the complete SESRSYN function and block of the Synchronizing function respectively. TSTSYNCH will allow testing of the function where the fulfilled conditions are connected to a separate output.

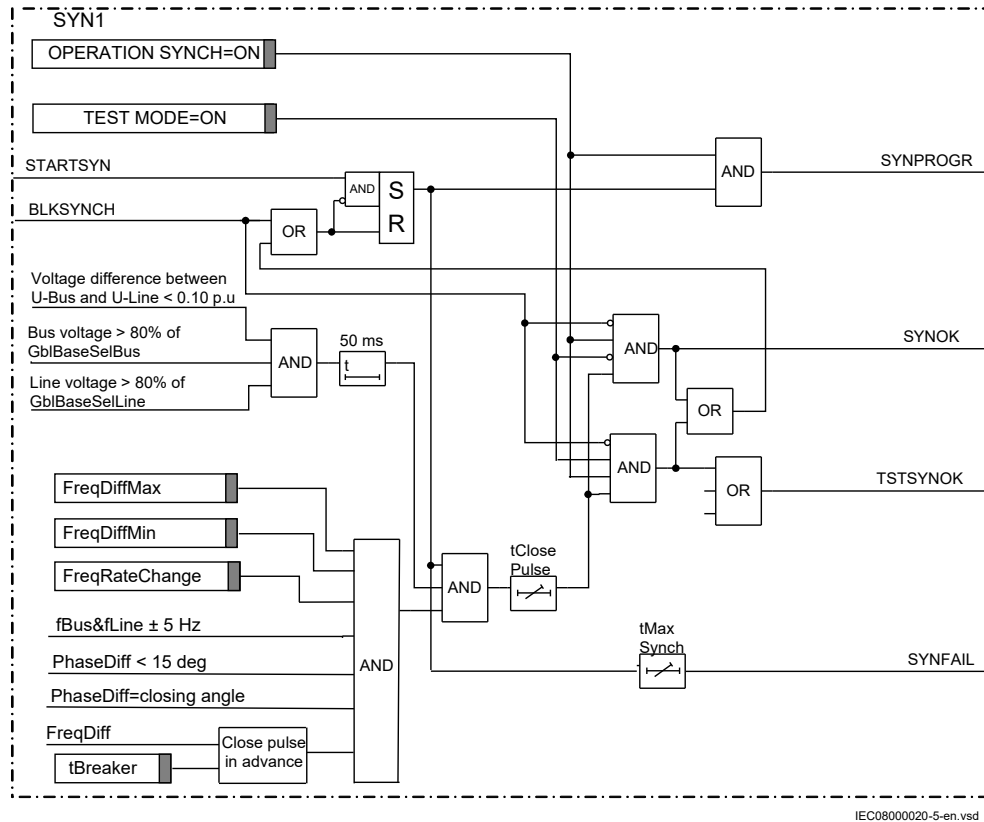

Figure 98: Simplified logic diagram for the synchronizing function

10.1.7.4 Energizing check

Voltage values are measured in the IED and are available for evaluation by the Energizing check function.

The function measures voltages on the busbar and the line to verify whether they are live or dead. To be considered live, the value must be above 80% of set U_{Base} selected for $GblBaseSelBus$ or $GblBaseSelLine$ and to be considered dead it must be below 40% of set U_{Base} selected for $GblBaseSelBus$ or $GblBaseSelLine$.

The frequency on both sides of the circuit breaker is also measured. The frequencies must not deviate from the rated frequency more than ± 5 Hz.

The Energizing direction can be selected individually for the Manual and the Automatic functions respectively. When the conditions are met the outputs AUTOENOK and MANENOK respectively will be activated if the fuse supervision conditions are fulfilled. The output signal can be delayed independently for MANENOK and AUTOENOK conditions. The Energizing direction can also be selected by an integer input AENMODE respective MENMODE, which for example, can be connected to a Binary to Integer function block (B16I). Integers supplied shall be 1=off, 2=DLLB, 3=DBLL and 4= Both. Not connected input with connection of INTZERO output from Fixed Signals (FIXDSIGN) function block will mean that the setting is done from

Parameter Setting tool. The active position can be read on outputs MODEAEN resp MODEMEN. The modes are 0=OFF, 1=DLLB, 2=DBLL and 3=Both.

The inputs BLOCK and BLKENERG are available for total block of the complete SESRSYN function respective block of the Energizing check function. TSTENERG will allow testing of the function where the fulfilled conditions are connected to a separate test output.

10.1.7.5 Fuse failure supervision

External fuse failure signals or signals from a tripped fuse switch/MCB are connected to binary inputs that are configured to the inputs of SESRSYN function in the IED. Alternatively, the internal signals from fuse failure supervision can be used when available. There are two alternative connection possibilities. Inputs labelled OK must be connected if the available contact indicates that the voltage circuit is healthy. Inputs labelled FF must be connected if the available contact indicates that the voltage circuit is faulty.

The UB1OK/UB2OK and UB1FF/UB2FF inputs are related to the busbar voltage and the ULN1OK/ULN2OK and ULN1FF/ULN2FF inputs are related to the line voltage. Configure them to the binary input or function outputs that indicate the status of the external fuse failure of the busbar and line voltages. In the event of a fuse failure, the energizing check function is blocked. The synchronizing and the synchrocheck function requires full voltage on both sides, thus no blocking at fuse failure is needed.

10.1.7.6 Voltage selection

The voltage selection module including supervision of included voltage transformers for the different arrangements is a basic part of the SESRSYN function and determines the voltages fed to the Synchronizing, Synchrocheck and Energizing check functions. This includes the selection of the appropriate Line and Bus voltages and MCB supervision.

The voltage selection type to be used is set with the parameter *CBConfig*.

If *No voltage sel.* is set the voltages used will be U-Line1 and U-Bus1. This setting is also used in the case when external voltage selection is provided. Fuse failure supervision for the used inputs must also be connected.

From the voltage selection part, selected voltages, and functions conditions are connected to the Synchronizing, Synchrocheck and Energizing check inputs.

For the disconnector positions it is advisable to use (NO) a and (NC) b type contacts to supply Disconnector Open and Closed positions but, it is also possible to use an inverter for one of the positions.

10.1.7.7 Voltage selection for a single circuit breaker with double busbars

This function uses the binary input from the disconnectors auxiliary contacts B1QOPEN-B1QCLD for Bus 1, and B2QOPEN-B2QCLD for Bus 2 to select between bus 1 and bus 2 voltages. If the disconnector connected to bus 1 is closed and the disconnector connected to bus 2 is opened the bus 1 voltage is used. All other combinations use the bus 2 voltage. The outputs B1SEL and B2SEL respectively indicate the selected Bus voltage.

The function checks the fuse-failure signals for bus 1, bus 2 and line voltage transformers. Inputs UB1OK-UB1FF supervise the MCB for Bus 1 and UB2OK-UB2FF supervises the MCB for Bus 2. ULN1OK and ULN1FF supervises the MCB for the Line voltage transformer. The inputs fail (FF) or healthy (OK) can alternatively be used dependent on the available signal. If a VT failure is detected in the selected voltage source an output signal USELFAIL is set. This output signal is true if the selected bus or line voltages have a VT failure. This output as well as the

function can be blocked with the input signal BLOCK. The function logic diagram is shown in figure 99.

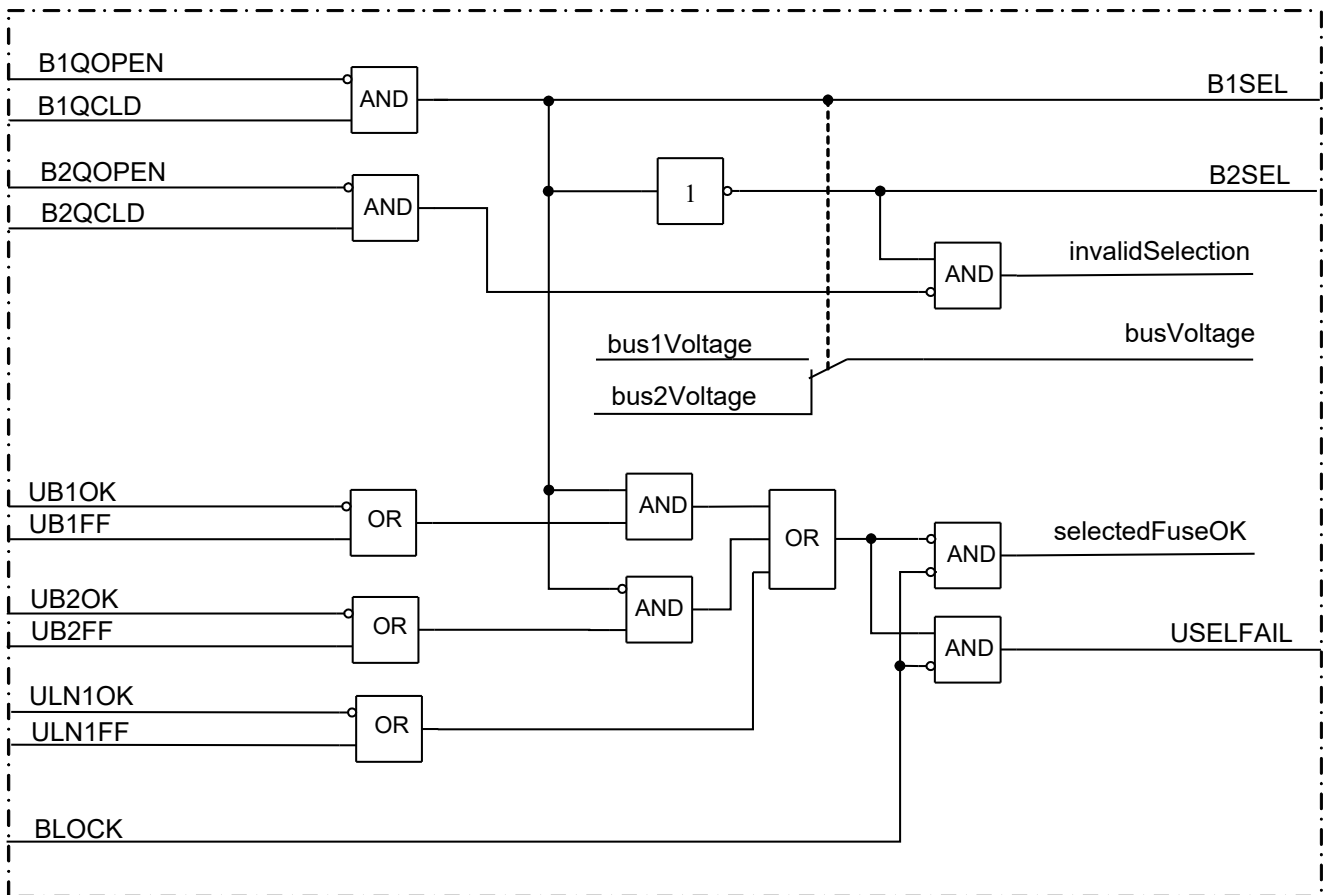

en05000779-2.vsd

Figure 99: Logic diagram for the voltage selection function of a single circuit breaker with double busbars

10.1.7.8 Voltage selection for a 1 1/2 circuit breaker arrangement

Note that with 1½ breaker schemes three Synchrocheck functions must be used for the complete diameter. Below, the scheme for one Bus breaker and the Tie breaker is described.

This voltage selection function uses the binary inputs from the disconnectors and circuit breakers auxiliary contacts to select the right voltage for the SESRSYN (Synchronism, Synchronizing and Energizing check) function. For the bus circuit breaker one side of the circuit breaker is connected to the busbar and the other side is connected either to line 1, line 2 or the other busbar depending on the best selection of voltage circuit.

Inputs LN1QOPEN-LN1QCLD, B1QOPEN-B1QCLD, B2QOPEN-B2QCLD, LN2QOPEN-LN2QCLD are inputs for the position of the Line disconnectors respectively the Bus and Tie breakers. The outputs LN1SEL, LN2SEL and B2SEL will give indication of the selected Line voltage as a reference to the fixed Bus 1 voltage, which indicates B1SEL.

The fuse supervision is connected to ULN1OK-ULN1FF, ULN2OK-ULN2FF and with alternative Healthy or Failing MCB signals depending on what is available from each MCB.

The tie circuit breaker is connected either to bus 1 or line 1 voltage on one side and the other side is connected either to bus 2 or line 2 voltage. Four different output combinations are possible, bus to bus, bus to line, line to bus and line to line.

- The line 1 voltage is selected if the line 1 disconnector is closed.
- The bus 1 voltage is selected if the line 1 disconnector is open and the bus 1 circuit breaker is closed.
- The line 2 voltage is selected if the line 2 disconnector is closed.
- The bus 2 voltage is selected if the line 2 disconnector is open and the bus 2 circuit breaker is closed.

The function also checks the fuse-failure signals for bus 1, bus 2, line 1 and line 2. If a VT failure is detected in the selected voltage an output signal USELFAIL is set. This output signal is true if the selected bus or line voltages have a MCB trip. This output as well as the function can be blocked with the input signal BLOCK. The function block diagram for the voltage selection of a bus circuit breaker is shown in figure 100 and for the tie circuit breaker in figure 101.

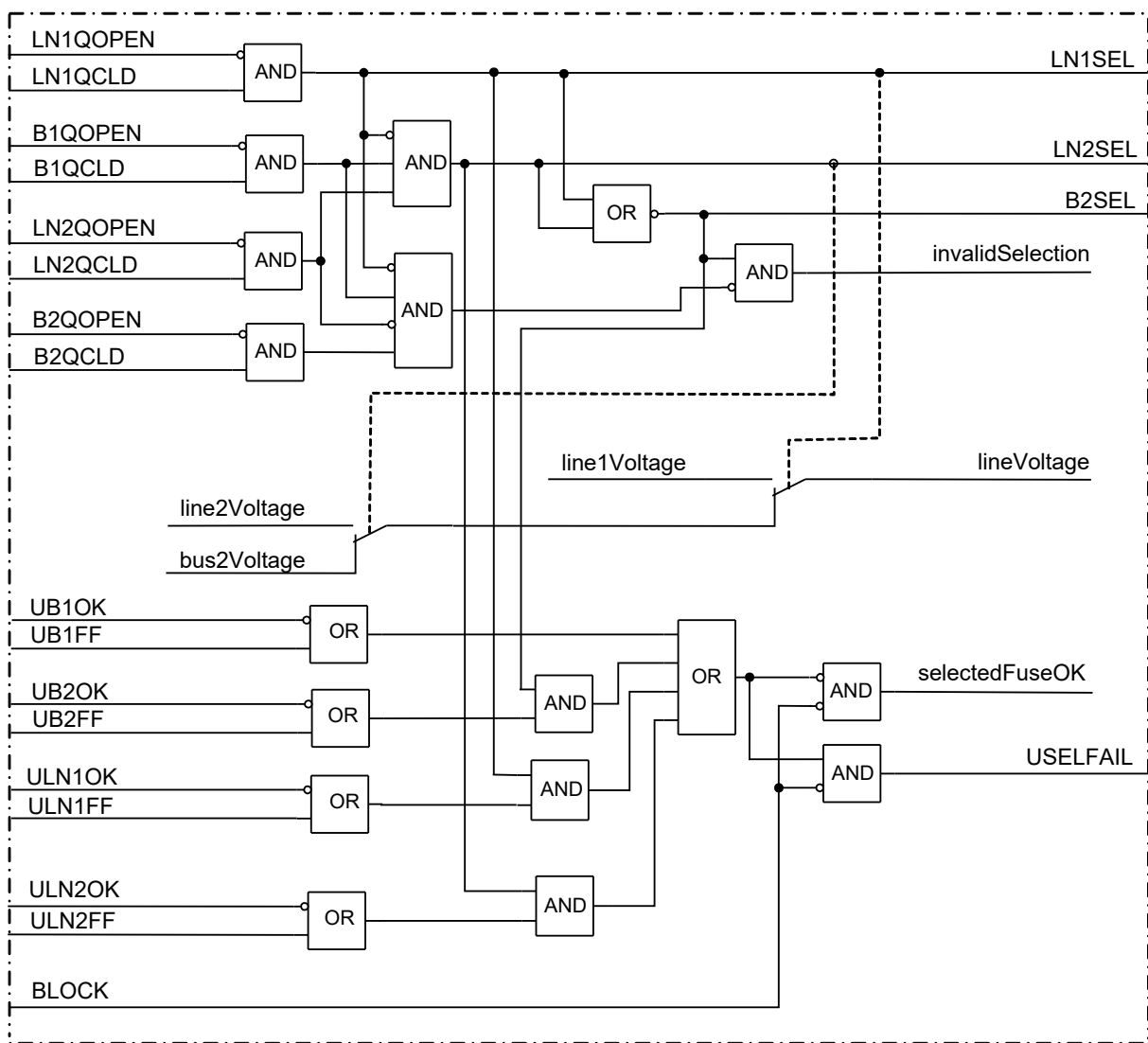

en05000780-2.vsd

Figure 100: Simplified logic diagram for the voltage selection function for a bus circuit breaker in a 1 1/2 breaker arrangement

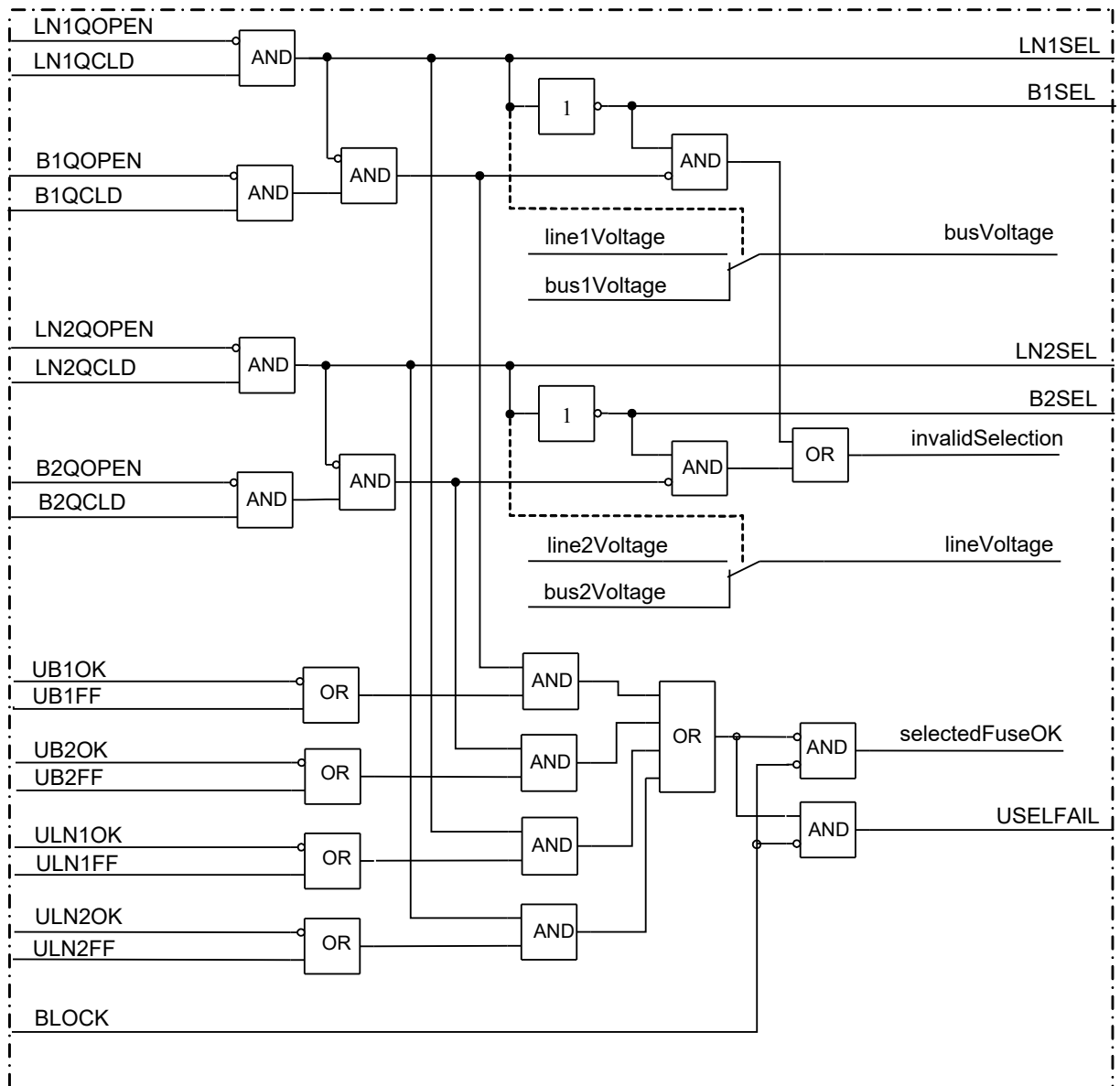

en05000781-2.vsd

Figure 101: Simplified logic diagram for the voltage selection function for the tie circuit breaker in 1 1/2 breaker arrangement.

10.1.8 Technical data

Table 170: SESRSYN technical data

Function	Range or value	Accuracy
Phase shift, $\varphi_{line} - \varphi_{bus}$	(-180 to 180) degrees	-
Voltage ratio, U_{bus}/U_{line}	0.500 - 2.000	-
Reset ratio, synchrocheck	> 95%	-
Frequency difference limit between bus and line for synchrocheck	(0.003-1.000) Hz	± 2.0 mHz
Table continues on next page		

Function	Range or value	Accuracy
Phase angle difference limit between bus and line for synchrocheck	(5.0-90.0) degrees	± 2.0 degrees
Voltage difference limit between bus and line for synchronizing and synchrocheck	0.03-0.50 p.u	± 0.5% of U_r
Time delay output for synchrocheck	(0.000-60.000) s	± 0.5% ± 25 ms
Frequency difference minimum limit for synchronizing	(0.003-0.250) Hz	± 2.0 mHz
Frequency difference maximum limit for synchronizing	(0.050-0.500) Hz	± 2.0 mHz
Maximum allowed frequency rate of change	(0.000-0.500) Hz/s	± 10.0 mHz/s
Closing time of the breaker	(0.000-60.000) s	± 0.5% ± 25 ms
Breaker closing pulse duration	(0.050-60.000) s	± 0.5% ± 25 ms
tMaxSynch, which resets synchronizing function if no close has been made before set time	(0.000-60.000) s	± 0.5% ± 25 ms
Minimum time to accept synchronizing conditions	(0.000-60.000) s	± 0.5% ± 25 ms
Time delay output for energizing check	(0.000-60.000) s	± 0.5% ± 25 ms
Operate time for synchrocheck function	40 ms typically	-
Operate time for energizing function	100 ms typically	-

10.2 Autorecloser for 3-phase operation SMBRREC

10.2.1 Identification

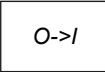
Function Description	IEC 61850 identification	IEC 60617 identification	ANSI/IEEE C37.2 device number
Autorecloser for 3-phase operation	SMBRREC		79

10.2.2 Functionality

The autorecloser for 3-phase operation SMBRREC function provides high-speed and/or delayed auto-reclosing for single breaker applications.

Up to five three-phase reclosing attempts can be included by parameter setting.

The autoreclosing function is configured to co-operate with the synchrocheck function.

10.2.3 Function block

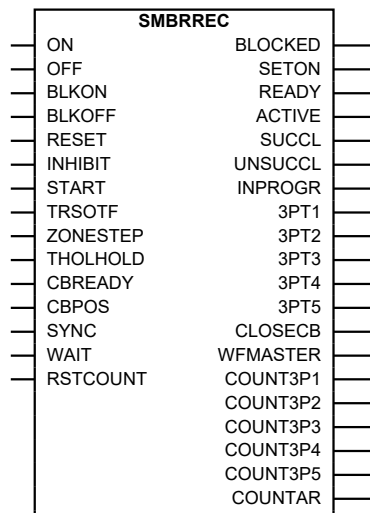

IEC0800086_1_en.vsd

Figure 102: SMBRREC function block

10.2.4 Signals

Table 171: SMBRREC Input signals

Name	Type	Default	Description
ON	BOOLEAN	0	Switches AR On when Operation = ExternalCtrl
OFF	BOOLEAN	0	Switches AR Off when Operation = ExternalCtrl
BLKON	BOOLEAN	0	Sets AR in blocked state
BLKOFF	BOOLEAN	0	Releases AR from blocked state
RESET	BOOLEAN	0	Resets AR to initial conditions
INHIBIT	BOOLEAN	0	Interrupts and inhibits reclosing sequence
START	BOOLEAN	0	Reclosing sequence starts by a protection trip signal
TRSOTF	BOOLEAN	0	Makes AR to continue to shots 2-5 at a trip from SOTF
ZONESTEP	BOOLEAN	0	Coordination between local AR and down stream devices
THOLHOLD	BOOLEAN	0	Holds AR in wait state
CBREADY	BOOLEAN	0	CB must be ready for CO/OCO operation to allow start / close
CBPOS	BOOLEAN	0	Status of the circuit breaker Closed/Open
SYNC	BOOLEAN	0	Synchronizing check fulfilled for 3Ph closing attempts
WAIT	BOOLEAN	0	Wait for master in Multi-breaker arrangements
RSTCOUNT	BOOLEAN	0	Resets all counters

Table 172: SMBRREC Output signals

Name	Type	Description
BLOCKED	BOOLEAN	AR is in blocked state
SETON	BOOLEAN	AR operation is switched on
READY	BOOLEAN	Indicates that AR is ready for a new sequence
ACTIVE	BOOLEAN	Reclosing sequence in progress
SUCCL	BOOLEAN	Activated if CB closes during the time tUnsucCl
UNSUCCL	BOOLEAN	Reclosing unsuccessful, signal resets after the reclaim time
INPROGR	BOOLEAN	Reclosing shot in progress, activated during open time
3PT1	BOOLEAN	Three-phase reclosing in progress, shot 1
3PT2	BOOLEAN	Three-phase reclosing in progress, shot 2
3PT3	BOOLEAN	Three-phase reclosing in progress, shot 3
3PT4	BOOLEAN	Three-phase reclosing in progress, shot 4
3PT5	BOOLEAN	Three-phase reclosing in progress, shot 5
CLOSECB	BOOLEAN	Closing command for CB
WFMASTER	BOOLEAN	Signal to Slave issued by Master for sequential reclosing
COUNT3P1	INTEGER	Counting the number of three-phase reclosing shot 1
COUNT3P2	INTEGER	Counting the number of three-phase reclosing shot 2
COUNT3P3	INTEGER	Counting the number of three-phase reclosing shot 3
COUNT3P4	INTEGER	Counting the number of three-phase reclosing shot 4
COUNT3P5	INTEGER	Counting the number of three-phase reclosing shot 5
COUNTAR	INTEGER	Counting total number of reclosing shots

10.2.5 Settings

Table 173: SMBRREC Group settings (basic)

Name	Values (Range)	Unit	Step	Default	Description
Operation	Off External ctrl On	-	-	External ctrl	Off / ExternalCtrl / On
t1 3Ph	0.000 - 60.000	s	0.001	6.000	Open time for shot 1, delayed reclosing 3ph
tReclaim	0.00 - 6000.00	s	0.01	60.00	Duration of the reclaim time
tSync	0.00 - 6000.00	s	0.01	30.00	Maximum wait time for synchrocheck OK
tTrip	0.000 - 60.000	s	0.001	0.200	Maximum trip pulse duration
tCBClosedMin	0.00 - 6000.00	s	0.01	5.00	Minimum time that CB must be closed before new sequence allows
tUnsucCl	0.00 - 6000.00	s	0.01	30.00	Wait time for CB before indicating Unsuccessful/Successful
Priority	None Low High	-	-	None	Priority selection between adjacent terminals None/Low/High
tWaitForMaster	0.00 - 6000.00	s	0.01	60.00	Maximum wait time for release from Master

Table 174: SMBRREC Group settings (advanced)

Name	Values (Range)	Unit	Step	Default	Description
NoOfShots	1 2 3 4 5	-	-	1	Maximum number of reclosing shots 1-5
StartByCBOpen	Off On	-	-	Off	To be set ON if AR is to be started by CB open position
CBAuxContType	NormClosed NormOpen	-	-	NormOpen	Select CB auxiliary contact type NC/NO for CBPOS input
CBReadyType	CO OCO	-	-	CO	Select type of circuit breaker ready signal CO/OCO
t2 3Ph	0.00 - 6000.00	s	0.01	30.00	Open time for shot 2, three-phase
t3 3Ph	0.00 - 6000.00	s	0.01	30.00	Open time for shot 3, three-phase
t4 3Ph	0.00 - 6000.00	s	0.01	30.00	Open time for shot 4, three-phase
t5 3Ph	0.00 - 6000.00	s	0.01	30.00	Open time for shot 5, three-phase
tInhibit	0.000 - 60.000	s	0.001	5.000	Inhibit reclosing reset time
Follow CB	Off On	-	-	Off	Advance to next shot if CB has been closed during dead time
AutoCont	Off On	-	-	Off	Continue with next reclosing-shot if breaker did not close
tAutoContWait	0.000 - 60.000	s	0.001	2.000	Wait time after close command before proceeding to next shot
UnsucClByCBChk	NoCBCheck CB check	-	-	NoCBCheck	Unsuccessful closing signal obtained by checking CB position
BlockByUnsucCl	Off On	-	-	Off	Block AR at unsuccessful reclosing
ZoneSeqCoord	Off On	-	-	Off	Coordination of down stream devices to local protection unit's AR

10.2.6 Operation principle

10.2.6.1 Start auto-reclosing and conditions for start of a reclosing cycle

The usual way in which to start a reclosing cycle, or sequence, is to start it when a line protection tripping has occurred, by applying a signal to the START input.

For a new auto-reclosing cycle to be started, a number of conditions need to be met. They are linked to dedicated inputs. The inputs are:

- CBREADY: CB ready for a reclosing cycle, for example, charged operating gear
- CBPOS: to ensure that the CB was closed when the line fault occurred and start was applied
- No blocking or inhibit signal shall be present.

After the start has been accepted, it is latched in and an internal signal "Started" is set. It can be interrupted by certain events, like an inhibit signal.

To start auto-reclosing by CB position Open instead of from protection trip signals, one has to configure the CB Open position signal to inputs CBPOS and START and set a parameter *StartByCBOpen* = *On* and *CBAuxContType* = *NormClosed* (normally closed). One also has to configure and connect signals from manual trip commands to input INHIBIT.

The logic for switching the auto-recloser *On/Off* and the starting of the reclosing is shown in figure 103. The following should be considered:

- Setting *Operation* can be set to *Off*, *External ctrl* or *On*. *External ctrl* offers the possibility of switching by external switches to inputs ON and OFF, communication commands to the same inputs, and so on.
- SMBRREC is normally started by tripping. It is either a Zone 1 and Communication aided trip, or a general trip. If the general trip is used the function must be blocked from all back-up tripping connected to INHIBIT. In both alternatives the breaker failure function must be connected to inhibit the function. START makes a first attempt with synchrocheck. TRSOTF starts shots 2-5.
- Circuit breaker checks that the breaker was closed for a certain length of time before the starting occurred and that the CB has sufficient stored energy to perform an auto-reclosing sequence and is connected to inputs CBPOS and CBREADY.

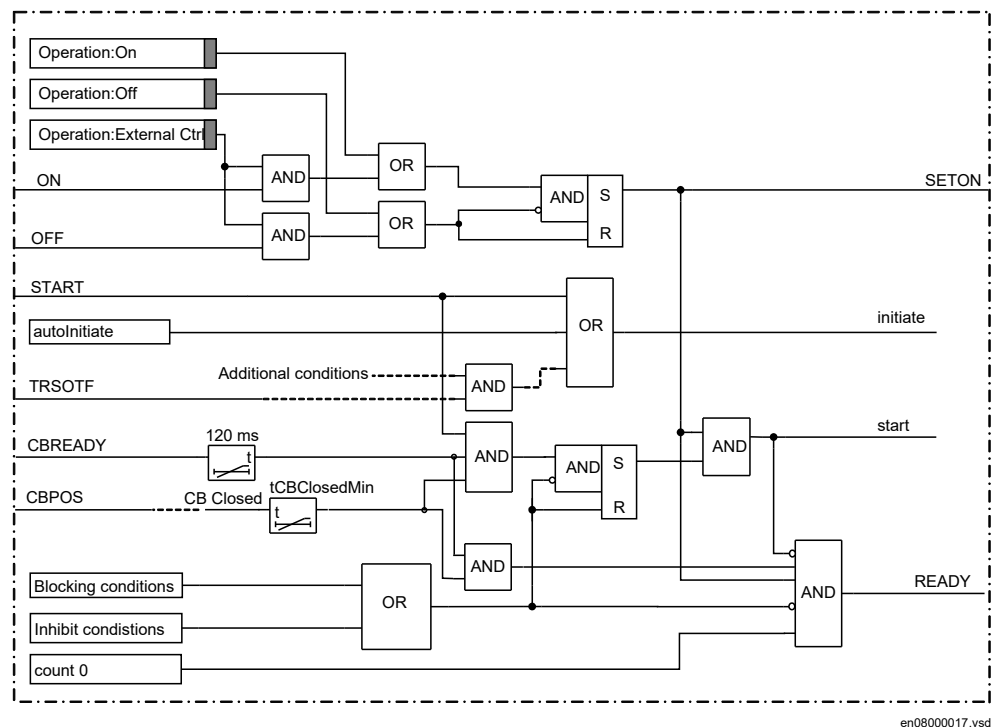

Figure 103: Auto-reclosing Off/On and start

10.2.6.2 Control of the auto-reclosing open time

There are settings for three-phase auto-reclosing open time, $t1\ 3Ph$ to $t5\ 3Ph$.

10.2.6.3 Long trip signal

In normal circumstances the trip command resets quickly due to fault clearing. The user can set a maximum trip pulse duration t_{Trip} . A long trip signal interrupts the reclosing sequence in the same way as a signal to input INHIBIT.

Reclosing checks and the reclaim timer

When dead time has elapsed during the auto-reclosing procedure certain conditions must be fulfilled before the CB closing command is issued. To achieve this, signals are exchanged between program modules to check that these conditions are met. In three-phase reclosing a synchronizing and/or energizing check can be used. It is possible to use a synchro-check

function in the same physical device or an external one. The release signal is configured by connecting to the auto-reclosing function input SYNC. If reclosing without checking is preferred the SYNC input can be set to TRUE (set high). Another possibility is to set the output of the synchro-check function to a permanently activated state. At confirmation from the synchro-check, the signal passes on.

By choosing *CBReadyType* = CO (CB ready for a Close-Open sequence) the readiness of the circuit breaker is also checked before issuing the CB closing command. If the CB has a readiness contact of type *CBReadyType* = OCO (CB ready for an Open-Close-Open sequence) this condition may not be complied with after the tripping and at the moment of reclosure. The Open-Close-Open condition was however checked at the start of the reclosing cycle and it is then likely that the CB is prepared for a Close-Open sequence.

The synchro-check or energizing check must be fulfilled within a set time interval, *tSync*. If it is not, or if other conditions are not met, the reclosing is interrupted and blocked.

The reclaim timer defines a time from the issue of the reclosing command, after which the reclosing function resets. Should a new trip occur during this time, it is treated as a continuation of the first fault. The reclaim timer is started when the CB closing command is given.

A number of outputs for Autoreclosing state control keeps track of the actual state in the reclosing sequence.

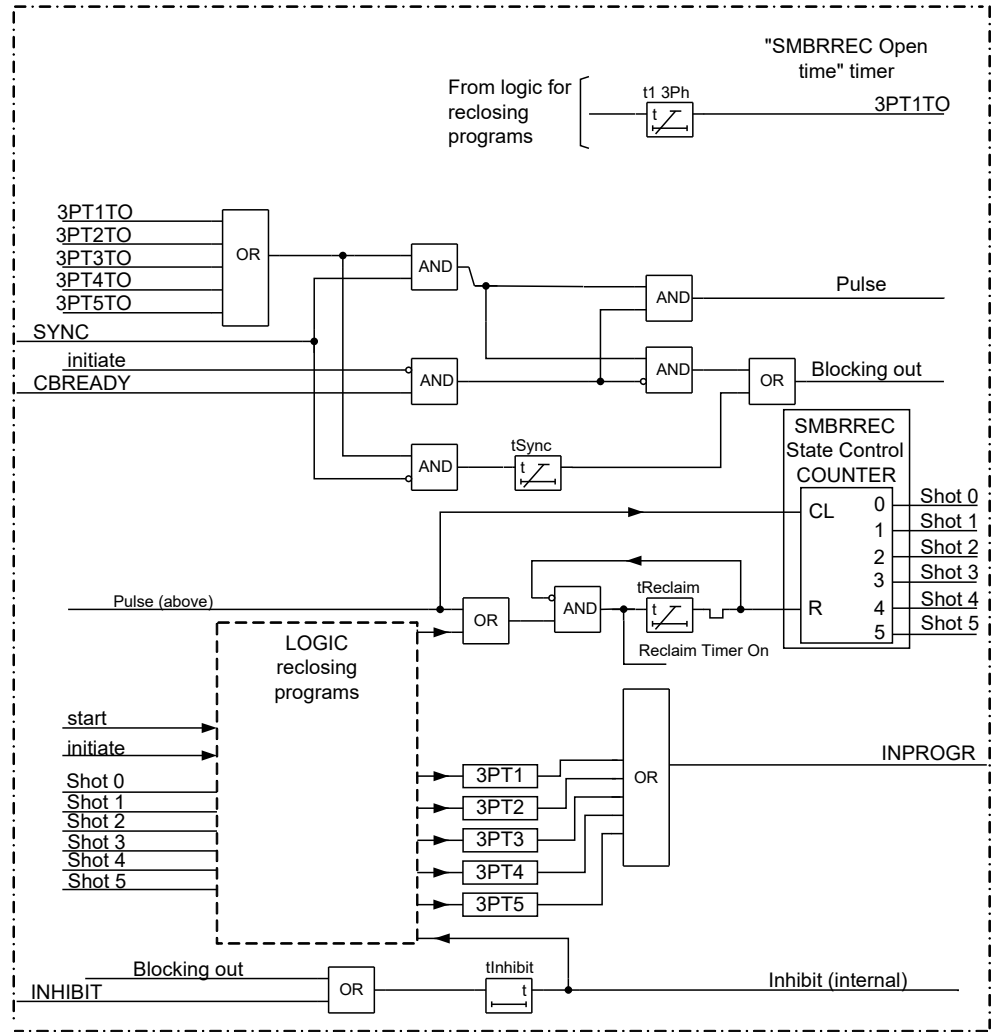

IEC08000244-2-en.vsd

Figure 104: Reclosing Reclaim and Inhibit timers

Pulsing of the CB closing command

The duration of the pulse is fixed 200 ms. See figure 105

When a reclosing command is issued, the appropriate reclosing operation counter is incremented. There is a counter for each reclosing shot and one for the total number of reclosing commands issued.

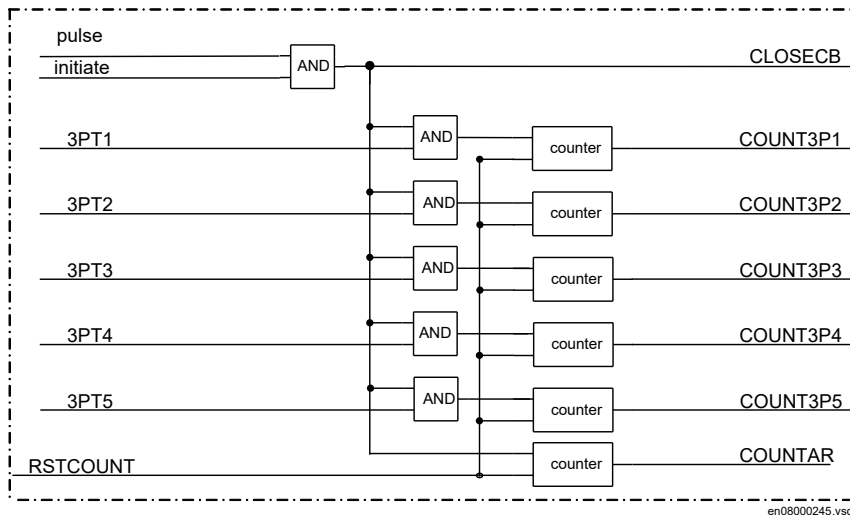

Figure 105: Pulsing of closing command and driving the operation counters

Transient fault

After the reclosing command the reclaim timer $tReclaim$ starts running for the set time. If no tripping occurs within this time, the auto-reclosing will reset.

Permanent fault and reclosing unsuccessful signal

If a new trip occurs after the CB closing command, and a new input signal START or TRSOTF appears, the output UNSUCCL (unsuccessful closing) is set high. The timers for the first shot can no longer be started. Depending on the setting for the number of reclosing shots, further shots may be made or the reclosing sequence will be ended. After the reclaim time has elapsed, the auto-reclosing function resets but the CB remains open. The CB closed data at the CBPOS input will be missing. Because of this, the reclosing function will not be ready for a new reclosing cycle.

Normally the signal UNSUCCL appears when a new trip and start is received after the last reclosing shot has been made and the auto-reclosing function is blocked. The signal resets once the reclaim time has elapsed. The “unsuccessful” signal can also be made to depend on CB position input. The parameter $UnsucClByCBchk$ should then be set to $CBcheck$, and a timer $tUnsucCl$ should also be set. If the CB does not respond to the closing command and does not close, but remains open, the output UNSUCCL is set high after time $tUnsucCl$.

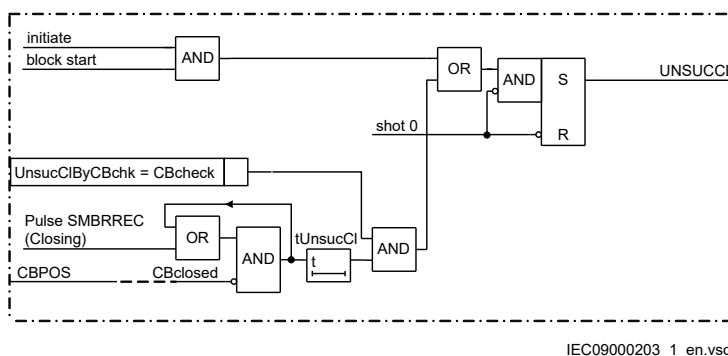

Figure 106: Issue of signal UNSUCCL, unsuccessful reclosing

Automatic continuation of the reclosing sequence

The auto-reclosing function can be programmed to proceed to the following reclosing shots (if selected) even if the start signals are not received from the protection functions, but the

breaker is still not closed. This is done by setting parameter *AutoCont* = *On* and *tAutoContWait* to the required delay for the function to proceed without a new start.

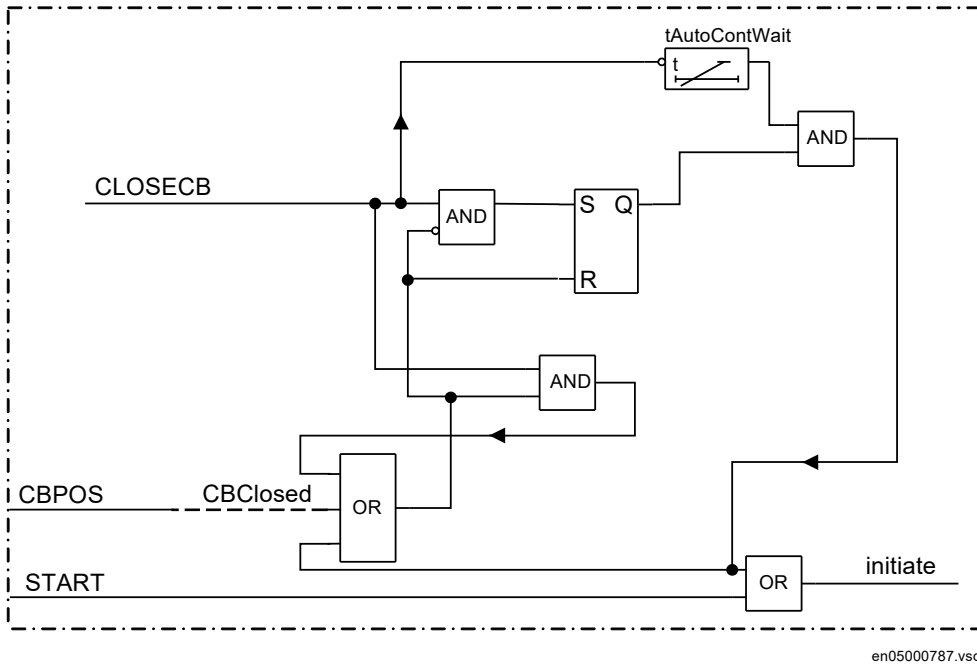

Figure 107: Automatic proceeding of shot 2 to 5

Start of reclosing from CB open information

If a user wants to apply starting of auto-reclosing from CB open position instead of from protection trip signals, the function offers such a possibility. This starting mode is selected by a setting parameter *StartByCBOpen* = *On*. One needs then to block reclosing at all manual trip operations. Typically, one also set *CBAuxContType* = *NormClosed* and connect a CB auxiliary contact of type NC (normally closed) to inputs CBPOS and START. When the signal changes from CB closed to CB open an auto-reclosing start pulse of limited length is generated and latched in the function, subject to the usual checks. Then the reclosing sequence continues as usual. One needs to connect signals from manual tripping and other functions, which shall prevent reclosing, to the input INHIBIT.

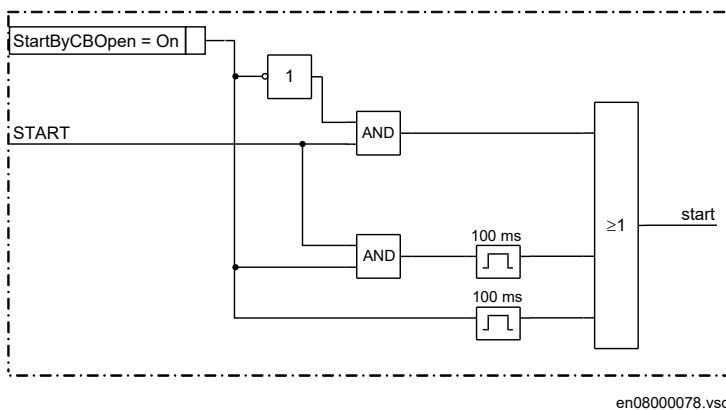

Figure 108: Pulsing of the start inputs

10.2.7 Technical data

Table 175: SMBRREC technical data

Function	Range or value	Accuracy
Number of autoreclosing shots	1 - 5	-
Autoreclosing open time: shot 1 - t1 3Ph	(0.000-60.000) s	± 0.5% ± 25 ms
shot 2 - t2 3Ph shot 3 - t3 3Ph shot 4 - t4 3Ph shot 5 - t5 3Ph	(0.00-6000.00) s	
Autorecloser maximum wait time for sync	(0.00-6000.00) s	
Maximum trip pulse duration	(0.000-60.000) s	
Inhibit reset time	(0.000-60.000) s	
Reclaim time	(0.00-6000.00) s	
Minimum time CB must be closed before AR becomes ready for autoreclosing cycle	(0.00-6000.00) s	
CB check time before unsuccessful	(0.00-6000.00) s	
Wait for master release	(0.00-6000.00) s	
Wait time after close command before proceeding to next shot	(0.000-60.000) s	

10.3 Apparatus control

10.3.1 Functionality

The apparatus control function APC8 for up to 8 apparatuses is used for control and supervision of circuit breakers, disconnectors and earthing switches within a bay. Permission to operate is given after evaluation of conditions from other functions such as interlocking, synchrocheck, operator place selection and external or internal blockings.

In normal security, the command is processed and the resulting position is not supervised. However with enhanced security, the command is processed and the resulting position is supervised.

The switch controller SCSWI initializes and supervises all functions to properly select and operate switching primary apparatuses. Each of the 8 switch controllers SCSWI may handle and operate on one three-phase apparatus.

Each of the 3 circuit breaker controllers SXCBR provides the actual position status and pass the commands to the primary circuit breaker and supervises the switching operation and positions.

Each of the 7 circuit switch controllers SXSXI provides the actual position status and pass the commands to the primary disconnectors and earthing switches and supervises the switching operation and positions.

10.3.2 Switch controller SCSWI

10.3.2.1 Identification

Function description	IEC 61850 identification	IEC 60617 identification	ANSI/IEEE C37.2 device number
Switch controller	SCSWI	-	-

10.3.2.2 Functionality

The Switch controller (SCSWI) initializes and supervises all functions to properly select and operate switching primary apparatuses. The Switch controller may handle and operate on one three-phase device.

10.3.2.3 Function block

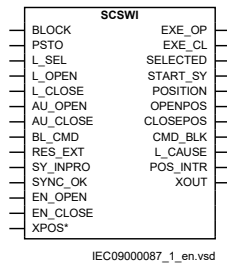

Figure 109: SCSWI function block

10.3.2.4 Signals

Table 176: SCSWI Input signals

Name	Type	Default	Description
BLOCK	BOOLEAN	0	Block of function
PSTO	INTEGER	2	Operator place selection
L_SEL	BOOLEAN	0	Select signal from local panel
L_OPEN	BOOLEAN	0	Open signal from local panel
L_CLOSE	BOOLEAN	0	Close signal from local panel
AU_OPEN	BOOLEAN	0	Used for local automation function
AU_CLOSE	BOOLEAN	0	Used for local automation function
BL_CMD	BOOLEAN	0	Steady signal for block of the command
RES_EXT	BOOLEAN	0	Reservation is made externally
SY_INPRO	BOOLEAN	0	Synchronizing function in progress
SYNC_OK	BOOLEAN	0	Closing is permitted at set to true by the synchrocheck
EN_OPEN	BOOLEAN	0	Enables open operation
EN_CLOSE	BOOLEAN	0	Enables close operation
XPOS	GROUP SIGNAL	-	Group signal from XCBR/XSWI

Table 177: SCSWI Output signals

Name	Type	Description
EXE_OP	BOOLEAN	Execute command for open direction
EXE_CL	BOOLEAN	Execute command for close direction
SELECTED	BOOLEAN	Select conditions are fulfilled
START_SY	BOOLEAN	Starts the synchronizing function
POSITION	INTEGER	Position indication
OPENPOS	BOOLEAN	Open position indication
CLOSEPOS	BOOLEAN	Closed position indication
CMD_BLK	BOOLEAN	Commands are blocked
L_CAUSE	INTEGER	Latest value of the error indication during command
POS_INTR	BOOLEAN	Stopped in intermediate position
XOUT	BOOLEAN	Execution information to XCBR/XSWI

10.3.2.5 Settings

Table 178: SCSWI Non group settings (basic)

Name	Values (Range)	Unit	Step	Default	Description
CtlModel	Dir Norm SBO Enh	-	-	SBO Enh	Specifies control model type
PosDependent	Always permitted Not perm at 00/11	-	-	Always permitted	Permission to operate depending on the position
tSelect	0.000 - 60.000	s	0.001	30.000	Maximum time between select and execute signals
tSynchrocheck	0.00 - 600.00	s	0.01	10.00	Allowed time for synchrocheck to fulfil close conditions
tSynchronizing	0.00 - 600.00	s	0.01	0.00	Supervision time to get the signal synchronizing in progress
tExecutionFB	0.00 - 600.00	s	0.01	30.00	Maximum time from command execution to termination

10.3.3 Circuit breaker SXCBR

10.3.3.1 Identification

Function description	IEC 61850 identification	IEC 60617 identification	ANSI/IEEE C37.2 device number
Circuit breaker	SXCBR	-	-

10.3.3.2 Functionality

The purpose of Circuit breaker (SXCBR) is to provide the actual status of positions and to perform the control operations, that is, pass all the commands to primary apparatuses in the

form of circuit breakers via binary output boards and to supervise the switching operation and position.

10.3.3.3 Function block

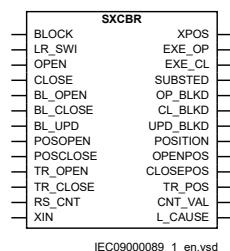

Figure 110: SXCBB function block

10.3.3.4 Signals

Table 179: SXCBB Input signals

Name	Type	Default	Description
BLOCK	BOOLEAN	0	Block of function
LR_SWI	BOOLEAN	0	Local/Remote switch indication from switchyard
OPEN	BOOLEAN	0	Pulsed signal used to immediately open the switch
CLOSE	BOOLEAN	0	Pulsed signal used to immediately close the switch
BL_OPEN	BOOLEAN	0	Signal to block the open command
BL_CLOSE	BOOLEAN	0	Signal to block the close command
BL_UPD	BOOLEAN	0	Steady signal for block of the position updating
POSOPEN	BOOLEAN	0	Signal for open position of apparatus from I/O
POSCLOSE	BOOLEAN	0	Signal for close position of apparatus from I/O
TR_OPEN	BOOLEAN	0	Signal for open position of truck from I/O
TR_CLOSE	BOOLEAN	0	Signal for close position of truck from I/O
RS_CNT	BOOLEAN	0	Resets the operation counter
XIN	BOOLEAN	0	Execution information from CSWI

Table 180: SXCBB Output signals

Name	Type	Description
XPOS	GROUP SIGNAL	Group connection to CSWI
EXE_OP	BOOLEAN	Executes the command for open direction
EXE_CL	BOOLEAN	Executes the command for close direction
OP_BLKD	BOOLEAN	Indication that the function is blocked for open commands
CL_BLKD	BOOLEAN	Indication that the function is blocked for close commands
UPD_BLKD	BOOLEAN	Update of position indication is blocked
POSITION	INTEGER	Apparatus position indication
OPENPOS	BOOLEAN	Apparatus open position
CLOSEPOS	BOOLEAN	Apparatus closed position

Table continues on next page

Name	Type	Description
TR_POS	INTEGER	Truck position indication
CNT_VAL	INTEGER	Operation counter value
L_CAUSE	INTEGER	Latest value of the error indication during command

10.3.3.5 Settings

Table 181: SXCBR Non group settings (basic)

Name	Values (Range)	Unit	Step	Default	Description
tStartMove	0.000 - 60.000	s	0.001	0.100	Supervision time for the apparatus to move after a command
tIntermediate	0.000 - 60.000	s	0.001	0.150	Allowed time for intermediate position
AdaptivePulse	Not adaptive Adaptive	-	-	Not adaptive	Output resets when a new correct end position is reached
tOpenPulse	0.000 - 60.000	s	0.001	0.200	Output pulse length for open command
tClosePulse	0.000 - 60.000	s	0.001	0.200	Output pulse length for close command
SuppressMidPos	Off On	-	-	On	Mid-position is suppressed during the time tIntermediate

10.3.4 Circuit switch SXSWI

10.3.4.1 Identification

Function description	IEC 61850 identification	IEC 60617 identification	ANSI/IEEE C37.2 device number
Circuit switch	SXSWI	-	-

10.3.4.2 Functionality

The purpose of Circuit switch (SXSWI) function is to provide the actual status of positions and to perform the control operations, that is, pass all the commands to primary apparatuses in the form of disconnectors or earthing switches via binary output boards and to supervise the switching operation and position.

10.3.4.3 Function block

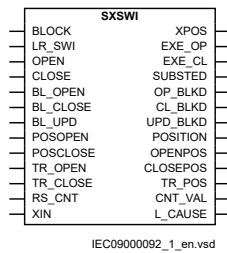

Figure 111: SXS WI function block

10.3.4.4 Signals

Table 182: SXS WI Input signals

Name	Type	Default	Description
BLOCK	BOOLEAN	0	Block of function
LR_SWI	BOOLEAN	0	Local/Remote switch indication from switchyard
OPEN	BOOLEAN	0	Pulsed signal used to immediately open the switch
CLOSE	BOOLEAN	0	Pulsed signal used to immediately close the switch
BL_OPEN	BOOLEAN	0	Signal to block the open command
BL_CLOSE	BOOLEAN	0	Signal to block the close command
BL_UPD	BOOLEAN	0	Steady signal for block of the position updating
POSOPEN	BOOLEAN	0	Signal for open position of apparatus from I/O
POSCLOSE	BOOLEAN	0	Signal for close position of apparatus from I/O
TR_OPEN	BOOLEAN	0	Signal for open position of truck from I/O
TR_CLOSE	BOOLEAN	0	Signal for close position of truck from I/O
RS_CNT	BOOLEAN	0	Resets the operation counter
XIN	BOOLEAN	0	Execution information from CSWI

Table 183: SXS WI Output signals

Name	Type	Description
XPOS	GROUP SIGNAL	Group connection to CSWI
EXE_OP	BOOLEAN	Executes the command for open direction
EXE_CL	BOOLEAN	Executes the command for close direction
OP_BLKD	BOOLEAN	Indication that the function is blocked for open commands
CL_BLKD	BOOLEAN	Indication that the function is blocked for close commands
UPD_BLKD	BOOLEAN	Update of position indication is blocked
POSITION	INTEGER	Apparatus position indication
OPENPOS	BOOLEAN	Apparatus open position
CLOSEPOS	BOOLEAN	Apparatus closed position
TR_POS	INTEGER	Truck position indication
CNT_VAL	INTEGER	Operation counter value
L_CAUSE	INTEGER	Latest value of the error indication during command

10.3.4.5 Settings

Table 184: SXS WI Non group settings (basic)

Name	Values (Range)	Unit	Step	Default	Description
tStartMove	0.000 - 60.000	s	0.001	3.000	Supervision time for the apparatus to move after a command
tIntermediate	0.000 - 60.000	s	0.001	15.000	Allowed time for intermediate position
AdaptivePulse	Not adaptive Adaptive	-	-	Not adaptive	Output resets when a new correct end position is reached
tOpenPulse	0.000 - 60.000	s	0.001	0.200	Output pulse length for open command
tClosePulse	0.000 - 60.000	s	0.001	0.200	Output pulse length for close command
SwitchType	Load Break Disconnecter Earthing Switch HS Earthing Switch	-	-	Disconnecter	1=LoadBreak,2=Disconnecter,3=Earth Sw,4=HighSpeedEarthSw
SuppressMidPos	Off On	-	-	On	Mid-position is suppressed during the time tIntermediate

10.3.5 Bay control QCBAY

10.3.5.1 Identification

Function description	IEC 61850 identification	IEC 60617 identification	ANSI/IEEE C37.2 device number
Bay control	QCBAY	-	-

10.3.5.2 Functionality

The Bay control QCBAY function is used together with Local remote and local remote control functions to handle the selection of the operator place per bay. QCBAY also provides blocking functions that can be distributed to different apparatuses within the bay.

10.3.5.3 Function block

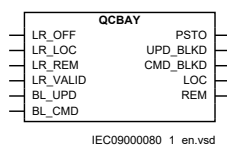

Figure 112: QCBAY function block

10.3.5.4 Signals

Table 185: QCBAY Input signals

Name	Type	Default	Description
LR_OFF	BOOLEAN	0	External Local/Remote switch is in Off position
LR_LOC	BOOLEAN	0	External Local/Remote switch is in Local position
LR_REM	BOOLEAN	0	External Local/Remote switch is in Remote position
LR_VALID	BOOLEAN	0	Data representing the L/R switch position is valid
BL_UPD	BOOLEAN	0	Steady signal to block the position updates
BL_CMD	BOOLEAN	0	Steady signal to block the command

Table 186: QCBAY Output signals

Name	Type	Description
PSTO	INTEGER	Value for the operator place allocation
UPD_BLKD	BOOLEAN	Update of position is blocked
CMD_BLKD	BOOLEAN	Function is blocked for commands
LOC	BOOLEAN	Local operation allowed
REM	BOOLEAN	Remote operation allowed

10.3.5.5 Settings

Table 187: QCBAY Non group settings (basic)

Name	Values (Range)	Unit	Step	Default	Description
AllPSTOValid	Priority No priority	-	-	Priority	Priority of originators

10.3.6 Local remote LOCREM

10.3.6.1 Identification

Function description	IEC 61850 identification	IEC 60617 identification	ANSI/IEEE C37.2 device number
Local remote	LOCREM	-	-

10.3.6.2 Functionality

The signals from the local HMI or from an external local/remote switch are applied via the function blocks LOCREM and LOCREMCTRL to the Bay control QCBAY function block. A parameter in function block LOCREM is set to choose if the switch signals are coming from the local HMI or from an external hardware switch connected via binary inputs.

10.3.6.3 Function block

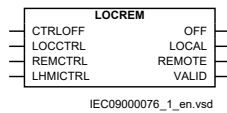

Figure 113: LOCREM function block

10.3.6.4 Signals

Table 188: LOCREM Input signals

Name	Type	Default	Description
CTRLLOFF	BOOLEAN	0	Disable control
LOCCTRL	BOOLEAN	0	Local in control
REMCTRL	BOOLEAN	0	Remote in control
LHMICTRL	INTEGER	0	LHMI control

Table 189: LOCREM Output signals

Name	Type	Description
OFF	BOOLEAN	Control is disabled
LOCAL	BOOLEAN	Local control is activated
REMOTE	BOOLEAN	Remote control is activated
VALID	BOOLEAN	Outputs are valid

10.3.6.5 Settings

Table 190: LOCREM Non group settings (basic)

Name	Values (Range)	Unit	Step	Default	Description
ControlMode	Internal LR-switch External LR-switch	-	-	Internal LR-switch	Control mode for internal/external LR-switch

10.3.7 Local remote control LOCREMCTRL

10.3.7.1 Identification

Function description	IEC 61850 identification	IEC 60617 identification	ANSI/IEEE C37.2 device number
Local remote control	LOCREMCTRL	-	-

10.3.7.2 Functionality

The signals from the local HMI or from an external local/remote switch are applied via the function blocks LOCREM and LOCREMCTRL to the Bay control QCBAY function block. A parameter in function block LOCREM is set to choose if the switch signals are coming from the local HMI or from an external hardware switch connected via binary inputs.

10.3.7.3 Function block

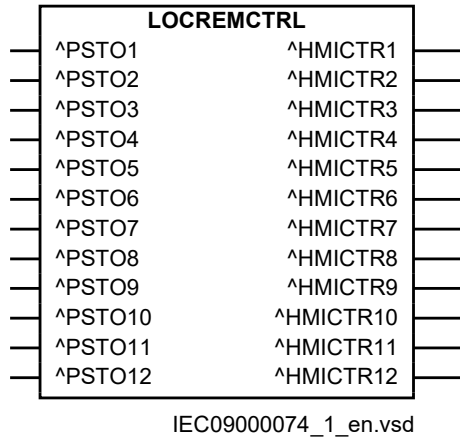

Figure 114: LOCREMCTRL function block

10.3.7.4 Signals

Table 191: LOCREMCTRL Input signals

Name	Type	Default	Description
PSTO1	INTEGER	0	PSTO input channel 1
PSTO2	INTEGER	0	PSTO input channel 2
PSTO3	INTEGER	0	PSTO input channel 3
PSTO4	INTEGER	0	PSTO input channel 4
PSTO5	INTEGER	0	PSTO input channel 5
PSTO6	INTEGER	0	PSTO input channel 6
PSTO7	INTEGER	0	PSTO input channel 7
PSTO8	INTEGER	0	PSTO input channel 8
PSTO9	INTEGER	0	PSTO input channel 9
PSTO10	INTEGER	0	PSTO input channel 10
PSTO11	INTEGER	0	PSTO input channel 11
PSTO12	INTEGER	0	PSTO input channel 12

Table 192: LOCREMCTRL Output signals

Name	Type	Description
HMICTR1	INTEGER	Bitmask output 1 to local remote LHMI input
HMICTR2	INTEGER	Bitmask output 2 to local remote LHMI input
HMICTR3	INTEGER	Bitmask output 3 to local remote LHMI input
HMICTR4	INTEGER	Bitmask output 4 to local remote LHMI input
HMICTR5	INTEGER	Bitmask output 5 to local remote LHMI input
HMICTR6	INTEGER	Bitmask output 6 to local remote LHMI input
HMICTR7	INTEGER	Bitmask output 7 to local remote LHMI input
HMICTR8	INTEGER	Bitmask output 8 to local remote LHMI input
HMICTR9	INTEGER	Bitmask output 9 to local remote LHMI input
HMICTR10	INTEGER	Bitmask output 10 to local remote LHMI input
HMICTR11	INTEGER	Bitmask output 11 to local remote LHMI input
HMICTR12	INTEGER	Bitmask output 12 to local remote LHMI input

10.3.7.5 Settings

The function does not have any parameters available in Local HMI or Protection and Control IED Manager (PCM600).

10.3.8 Select release SELGGIO

10.3.8.1 Identification

Function description	IEC 61850 identification	IEC 60617 identification	ANSI/IEEE C37.2 device number
Select release	SELGGIO	-	-

10.3.8.2 Function block

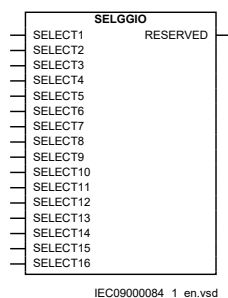

Figure 115: SELGGIO function block

10.3.8.3 Signals

Table 193: SELGGIO Input signals

Name	Type	Default	Description
SELECT1	BOOLEAN	0	Select signal of control 1
SELECT2	BOOLEAN	0	Select signal of control 2
SELECT3	BOOLEAN	0	Select signal of control 3
SELECT4	BOOLEAN	0	Select signal of control 4
SELECT5	BOOLEAN	0	Select signal of control 5
SELECT6	BOOLEAN	0	Select signal of control 6
SELECT7	BOOLEAN	0	Select signal of control 7
SELECT8	BOOLEAN	0	Select signal of control 8
SELECT9	BOOLEAN	0	Select signal of control 9
SELECT10	BOOLEAN	0	Select signal of control 10
SELECT11	BOOLEAN	0	Select signal of control 11
SELECT12	BOOLEAN	0	Select signal of control 12
SELECT13	BOOLEAN	0	Select signal of control 13
SELECT14	BOOLEAN	0	Select signal of control 14
SELECT15	BOOLEAN	0	Select signal of control 15
SELECT16	BOOLEAN	0	Select signal of control 16

Table 194: SELGGIO Output signals

Name	Type	Description
RESERVED	BOOLEAN	Reserved indication from bay/apparatus

10.3.8.4 Settings

The function does not have any parameters available in Local HMI or Protection and Control IED Manager (PCM600).

10.3.9 Operation principle

10.3.9.1 Switch controller SCSWI

The Switch controller (SCSWI) is provided with verification checks for the select - execute sequence, that is, checks the conditions prior each step of the operation. The involved functions for these condition verifications are interlocking, reservation, blockings and synchrocheck.

Control handling

Two types of control models can be used. The two control models are "direct with normal security" and "SBO (Select-Before-Operate) with enhanced security". The parameter *CtModel* defines which one of the two control models is used. The control model "direct with normal

security" does not require a select whereas, the "SBO with enhanced security" command model requires a select before execution.

Normal security means that only the command is evaluated and the resulting position is not supervised. Enhanced security means that the command sequence is supervised in three steps, the selection, command evaluation and the supervision of position. Each step ends up with a pulsed signal to indicate that the respective step in the command sequence is finished. If an error occurs in one of the steps in the command sequence, the sequence is terminated and the error is mapped into the enumerated variable "cause" attribute belonging to the pulsed response signal for the IEC 61850 communication. The last cause L_CAUSE can be read from the function block and used for example at commissioning.



There is no relation between the command direction and the actual position. For example, if the switch is in close position it is possible to execute a close command.

Before an execution command, an evaluation of the position is done. If the parameter *PosDependent* is true and the position is in intermediate state or in bad state no execution command is sent. If the parameter is false the execution command is sent independent of the position value.

Evaluation of position

The position output from switch (SXCBR or SXSWI) is connected to SCSWI. With the group signal connection the SCSWI obtains the position, time stamps and quality attributes of the position which is used for further evaluation.

In the supervision phase, the switch controller function evaluates the "cause" values from the switch modules Circuit breaker (SXCBR)/ Circuit switch (SXSWI). At error the "cause" value with highest priority is shown.

Blocking principles

The blocking signals are normally coming from the bay control function (QCBAY) and via the IEC 61850 communication from the operator place.



The IEC 61850 communication has always priority over binary inputs, e.g. a block command on binary inputs will not prevent commands over IEC 61850.

The different blocking possibilities are:

- Block/deblock of command. It is used to block command for operation of position.
- Blocking of function, BLOCK, signal from DO (Data Object) Behavior (IEC 61850). If DO Behavior is set to "blocked" it means that the function is active, but no outputs are generated, no reporting, control commands are rejected and functional and configuration data is visible.



The different block conditions will only affect the operation of this function, that is, no blocking signals will be "forwarded" to other functions. The above blocking outputs are stored in a non-volatile memory.

Interaction with synchrocheck and synchronizing functions

The Switch controller (SCSWI) works in conjunction with the synchrocheck and the synchronizing function (SESRYSYN). It is assumed that the synchrocheck function is continuously in operation and gives the result to SCSWI. The result from the synchrocheck function is evaluated during the close execution. If the operator performs an override of the synchrocheck, the evaluation of the synchrocheck state is omitted. When there is a positive

confirmation from the synchrocheck function, SCSWI will send the close signal EXE_CL to the switch function Circuit breaker (SXCBR).

When there is no positive confirmation from the synchrocheck function, SCSWI will send a start signal START_SY to the synchronizing function, which will send the closing command to SXCBR when the synchronizing conditions are fulfilled, see figure 116. If no synchronizing function is included, the timer for supervision of the "synchronizing in progress signal" is set to 0, which means no start of the synchronizing function. SCSWI will then set the attribute "blocked-by-synchrocheck" in the "cause" signal. See also the time diagram in figure 119.

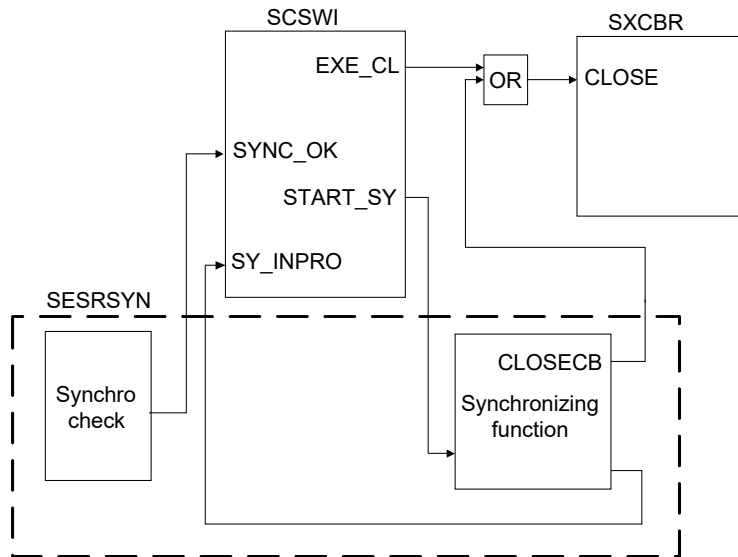

IEC09000209_1_en.vsd

Figure 116: Example of interaction between SCSWI, SESRSYN (synchrocheck and synchronizing function) and SXCBR function

Time diagrams

The Switch controller (SCSWI) function has timers for evaluating different time supervision conditions. These timers are explained here.

The timer *tSelect* is used for supervising the time between the select and the execute command, that is, the time the operator has to perform the command execution after the selection of the object to operate.

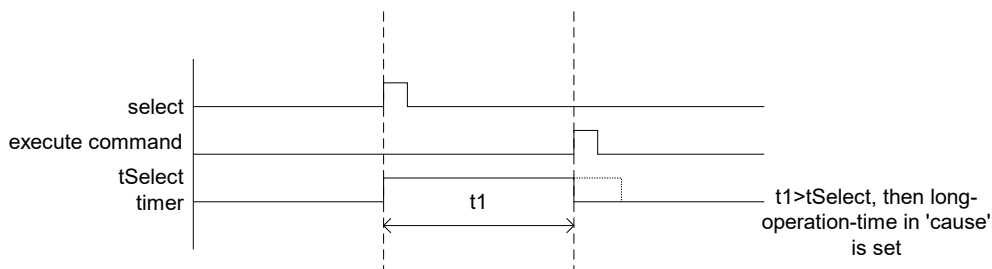

en05000092.vsd

Figure 117: *tSelect*

The timer *tExecutionFB* supervises the time between the execute command and the command termination, see figure 118.

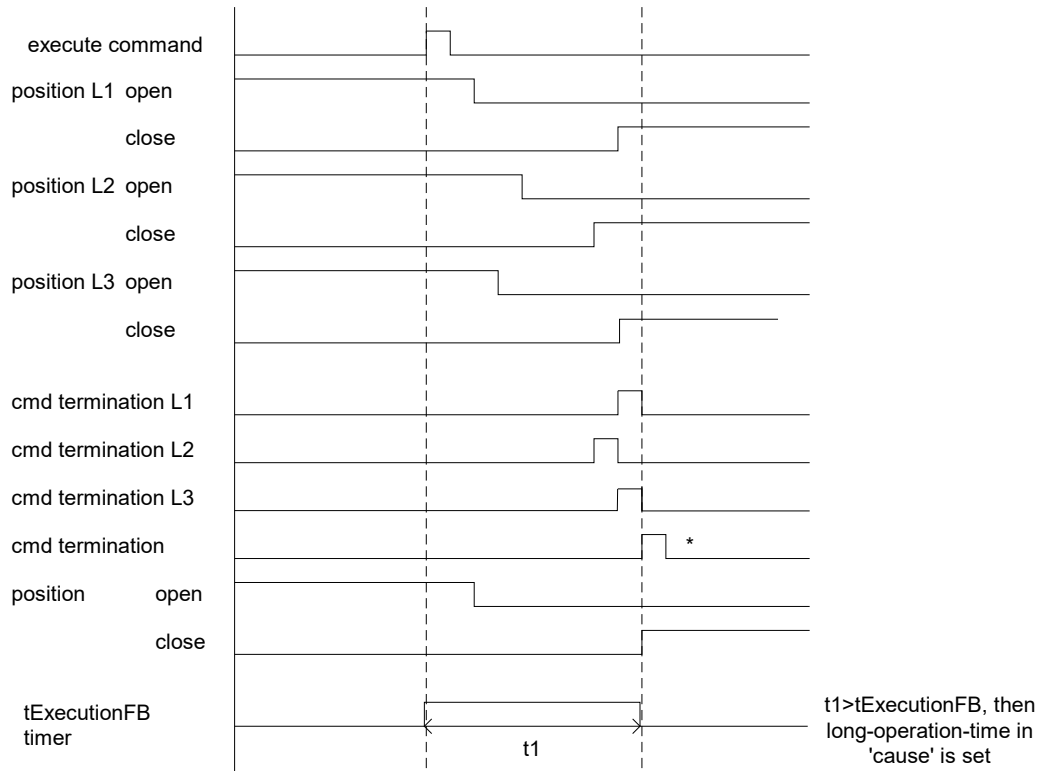

* The cmd termination will be delayed one execution sample.

en05000094.vsd

Figure 118: *tExecutionFB*

The parameter *tSynchronocheck* is used to define the maximum allowed time between the execute command and the input SYNC_OK to become true. If SYNC_OK=true at the time the execute command signal is received, the timer "tSynchronocheck" will not start. The start signal for the synchronizing is obtained if the synchronocheck conditions are not fulfilled.

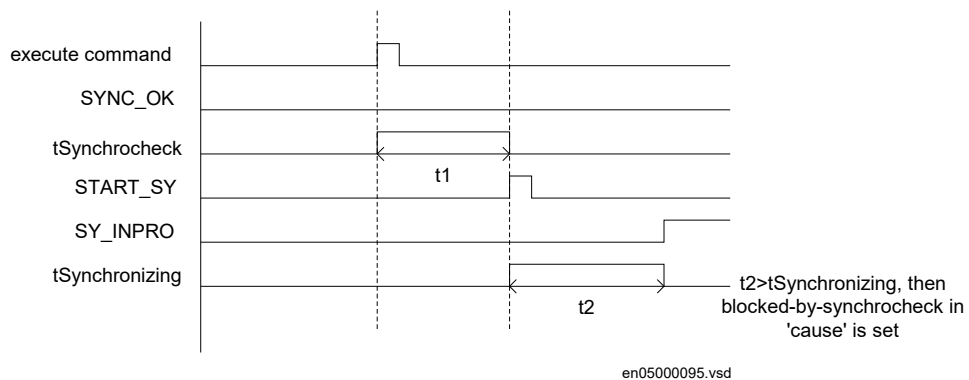

en05000095.vsd

Figure 119: *tSynchronoCheck and tSynchronizing*

Error handling

Depending on the error that occurs during the command sequence, the error signal will be set with a value. Table 195 describes vendor specific cause values in addition to these specified in IEC 61850-8-1 standard. The list of values of the "cause" are in order of priority. The values are available over the IEC 61850. An output L_CAUSE on the function block indicates the latest value of the error during the command.

Table 195: Values for "cause" signal in priority order

Apparatus control function	Description
-22	wrongCTLModel
-23	blockedForCommand
-24	blocked-for-open-command
-25	blocked-for-close-command
-30	longOperationTime
-31	switch-not-start-moving
-32	persistent-intermediate-state
-33	switch-returned-to-initial-position
-34	switch-in-bad-state
-35	not-expected-final-position

10.3.9.2 Circuit breaker SXCBR

The users of the Circuit breaker function (SXCBR) is other functions such as for example, switch controller, protection functions, autorecloser function or an IEC 61850 client residing in another IED or the operator place. This switch function executes commands, evaluates block conditions and evaluates different time supervision conditions. Only if all conditions indicate a switch operation to be allowed, the function performs the execution command. In case of erroneous conditions, the function indicates an appropriate "cause" value.

SXCBR has an operation counter for closing and opening commands. The counter value can be read remotely from the operator place. The value is reset from a binary input or remotely from the operator place by configuring a signal from the Single Point Generic Control 8 signals (SPC8GGIO) for example.

Local/Remote switch

One binary input signal LR_SWI is included in SXCBR to indicate the local/remote switch position from switchyard provided via the I/O board. If this signal is set to TRUE it means that change of position is allowed only from switchyard level. If the signal is set to FALSE it means that command from IED or higher level is permitted. When the signal is set to TRUE all commands (for change of position) from internal IED clients are rejected, even trip commands from protection functions are rejected. The functionality of the local/remote switch is described in figure 120.

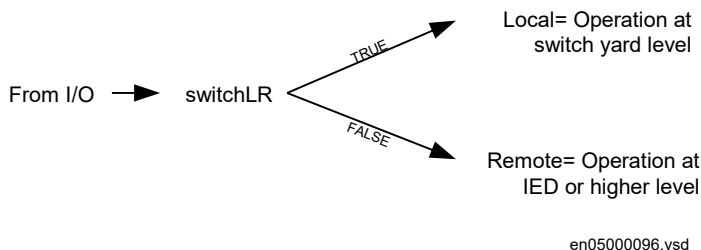

Figure 120: Local/Remote switch

Blocking principles

SXCBR includes several blocking principles. The basic principle for all blocking signals is that they will affect commands from all other clients for example, operators place, protection functions, autoreclosure and so on.



The IEC 61850 communication has always priority over binary inputs, e.g. a block command on binary inputs will not prevent commands over IEC 61850.

The blocking possibilities are:

- Block/deblock for open command. It is used to block operation for open command. Note that this block signal also affects the input OPEN for immediate command.
- Block/deblock for close command. It is used to block operation for close command. Note that this block signal also affects the input CLOSE for immediate command.
- Update block/deblock of positions. It is used to block the updating of position values. Other signals related to the position will be reset.
- Blocking of function, BLOCK, signal from DO (Data Object) Behavior (IEC 61850). If DO Behavior is set to "blocked" it means that the function is active, but no outputs are generated, no reporting, control commands are rejected and functional and configuration data is visible.

The above blocking outputs are stored in a non-volatile memory.

Substitution

The substitution part in SXCBR is used for manual set of the position for the switch. The typical use of substitution is that an operator enters a manual value because that the real process value is erroneous for some reason. SXCBR will then use the manually entered value instead of the value for positions determined by the process.



It is always possible to make a substitution, independently of the position indication and the status information of the I/O board. When substitution is enabled, the position values are blocked for updating. The substituted values are stored in a non-volatile memory.

Time diagrams

There are two timers for supervising of the execute phase, *tStartMove* and *tIntermediate*. *tStartMove* supervises that the primary device starts moving after the execute output pulse is sent. *tIntermediate* defines the maximum allowed time for intermediate position. Figure [121](#) explains these two timers during the execute phase.

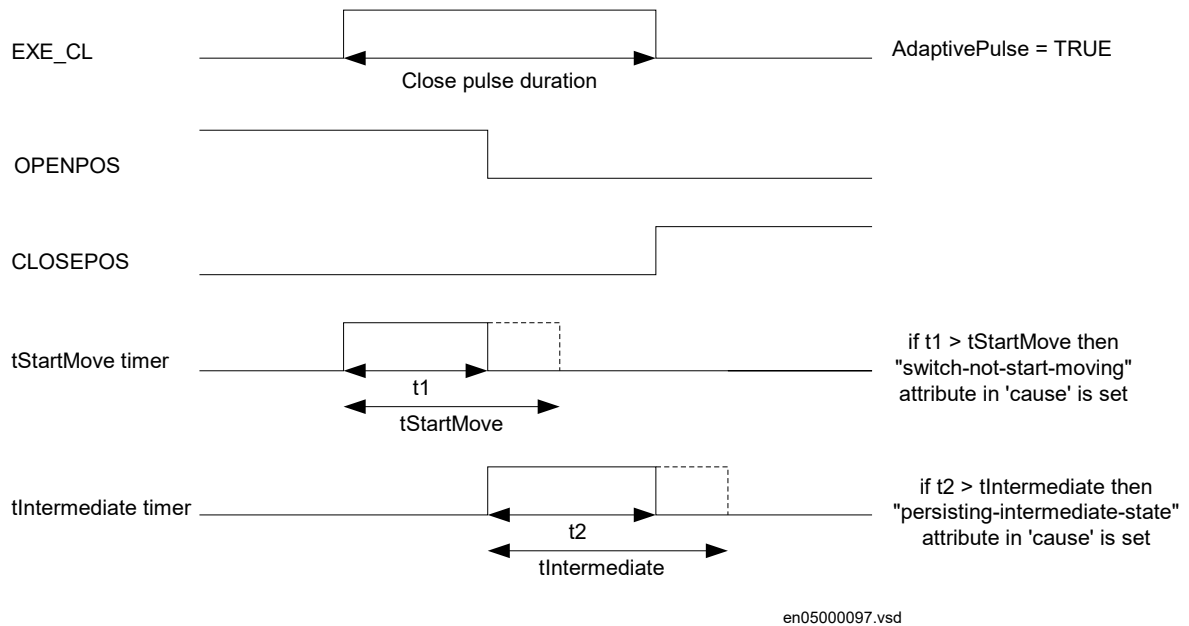

Figure 121: The timers *tStartMove* and *tIntermediate*

The timers *tOpenPulse* and *tClosePulse* are the length of the execute output pulses to be sent to the primary equipment. Note that the output pulses for open and close command can have different pulse lengths. The pulses can also be set to be adaptive with the configuration parameter *AdaptivePulse*. Figure 122 shows the principle of the execute output pulse. The *AdaptivePulse* parameter will have affect on both execute output pulses.

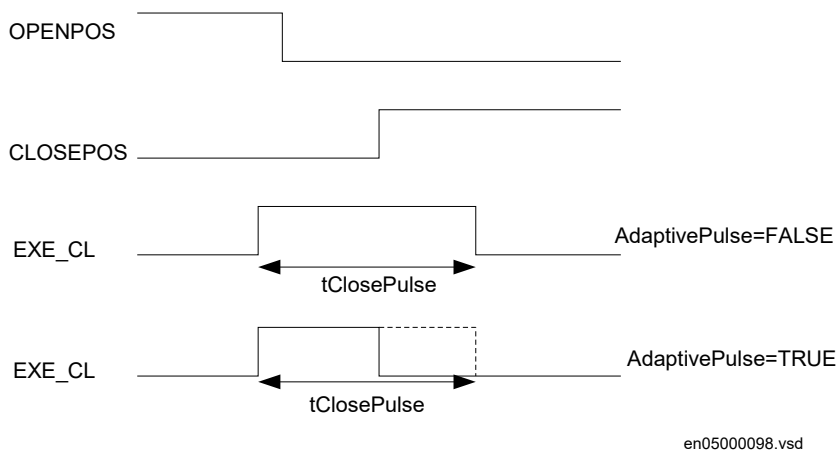

Figure 122: Execute output pulse

If the pulse is set to be adaptive, it is not possible for the pulse to exceed *tOpenPulse* or *tClosePulse*.

The execute output pulses are reset when:

- the new expected final position is reached and the configuration parameter *AdaptivePulse* is set to true
- the timer *tOpenPulse* or *tClosePulse* has elapsed
- an error occurs due to the switch does not start moving, that is, *tStartMove* has elapsed.

There is one exception from the first item above. If the primary device is in open position and an open command is executed or if the primary device is in closed position and a close

command is executed. In these cases, with the additional condition that the configuration parameter *AdaptivePulse* is true, the execute output pulse is always activated and resets when *tStartMove* has elapsed. If the configuration parameter *AdaptivePulse* is set to false the execution output remains active until the pulse duration timer has elapsed.



If the start position indicates bad state (OPENPOS=1 and CLOSEPOS =1) when a command is executed the execute output pulse resets only when timer *tOpenPulse* or *tClosePulse* has elapsed.

An example of when a primary device is open and an open command is executed is shown in figure 123.

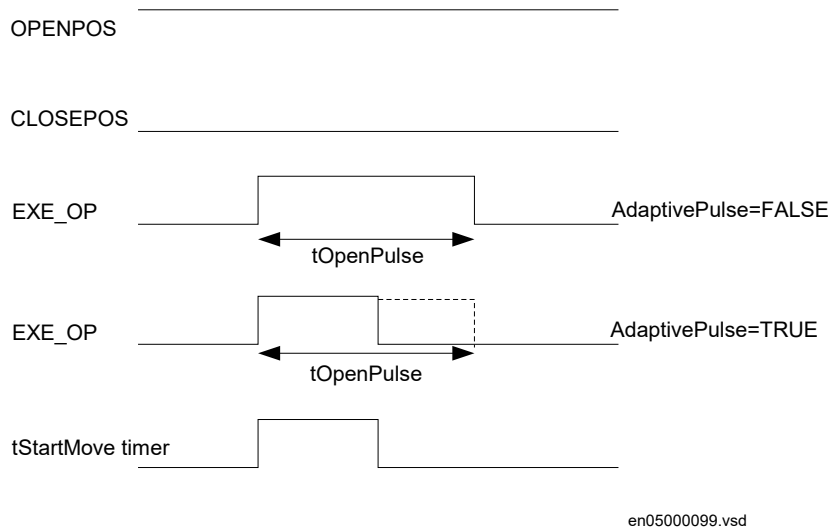

Figure 123: Open command with open position indication

Error handling

Depending on the error that occurs during the command sequence the error signal will be set with a value. Table 196 describes vendor specific cause values in addition to these specified in IEC 61850-8-1 standard. The list of values of the “cause” are in order of priority. The values are available over the IEC 61850. An output L_CAUSE on the function block indicates the latest value of the error during the command.

Table 196: Vendor specific cause values for Apparatus control in priority order

Apparatus control function	Description
-22	wrongCTLModel
-23	blockedForCommand
-24	blocked-for-open-command
-25	blocked-for-close-command
-30	longOperationTime
-31	switch-not-start-moving
-32	persistent-intermediate-state
-33	switch-returned-to-initial-position
-34	switch-in-bad-state
-35	not-expected-final-position

10.3.9.3 Circuit switch SXSWI

The users of the Circuit switch (SXSWI) is other functions such as for example, switch controller, protection functions, autorecloser function, or a 61850 client residing in another IED or the operator place. SXSWI executes commands, evaluates block conditions and evaluates different time supervision conditions. Only if all conditions indicate a switch operation to be allowed, SXSWI performs the execution command. In case of erroneous conditions, the function indicates an appropriate "cause" value.

SXSWI has an operation counter for closing and opening commands. The counter value can be read remotely from the operator place. The value is reset from a binary input or remotely from the operator place by configuring a signal from the Single Point Generic Control 8 signals (SPC8GGIO) for example.

Local/Remote switch

One binary input signal LR_SWI is included in SXSWI to indicate the local/remote switch position from switchyard provided via the I/O board. If this signal is set to TRUE it means that change of position is allowed only from switchyard level. If the signal is set to FALSE it means that command from IED or higher level is permitted. When the signal is set to TRUE all commands (for change of position) from internal IED clients are rejected, even trip commands from protection functions are rejected. The functionality of the local/remote switch is described in figure 124.

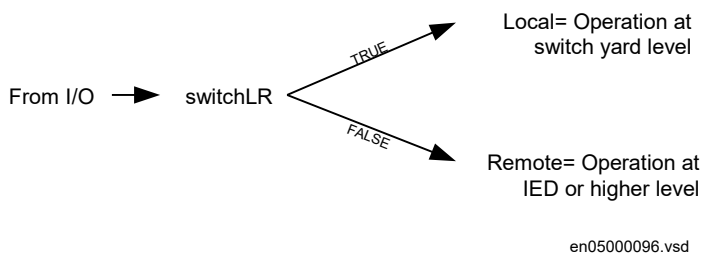

Figure 124: Local/Remote switch

Blocking principles

SXSWI includes several blocking principles. The basic principle for all blocking signals is that they will affect commands from all other clients for example, operators place, protection functions, autorecloser and so on.

The blocking possibilities are:

- Block/deblock for open command. It is used to block operation for open command. Note that this block signal also affects the input OPEN for immediate command.
- Block/deblock for close command. It is used to block operation for close command. Note that this block signal also affects the input CLOSE for immediate command.
- Update block/deblock of positions. It is used to block the updating of position values. Other signals related to the position will be reset.
- Blocking of function, BLOCK, signal from DO (Data Object) Behavior (IEC 61850). If DO Behavior is set to "blocked" it means that the function is active, but no outputs are generated, no reporting, control commands are rejected and functional and configuration data is visible.

The above blocking outputs are stored in a non-volatile memory.

Substitution

The substitution part in SXSWI is used for manual set of the position for the switch. The typical use of substitution is that an operator enters a manual value because the real process value is

erroneous of some reason. SXS WI will then use the manually entered value instead of the value for positions determined by the process.



It is always possible to make a substitution, independently of the position indication and the status information of the I/O board. When substitution is enabled, the position values are blocked for updating. The substituted values are stored in a non-volatile memory.

Time diagrams

There are two timers for supervising of the execute phase, $t_{StartMove}$ and $t_{Intermediate}$. $t_{StartMove}$ supervises that the primary device starts moving after the execute output pulse is sent. $t_{Intermediate}$ defines the maximum allowed time for intermediate position. Figure 125 explains these two timers during the execute phase.

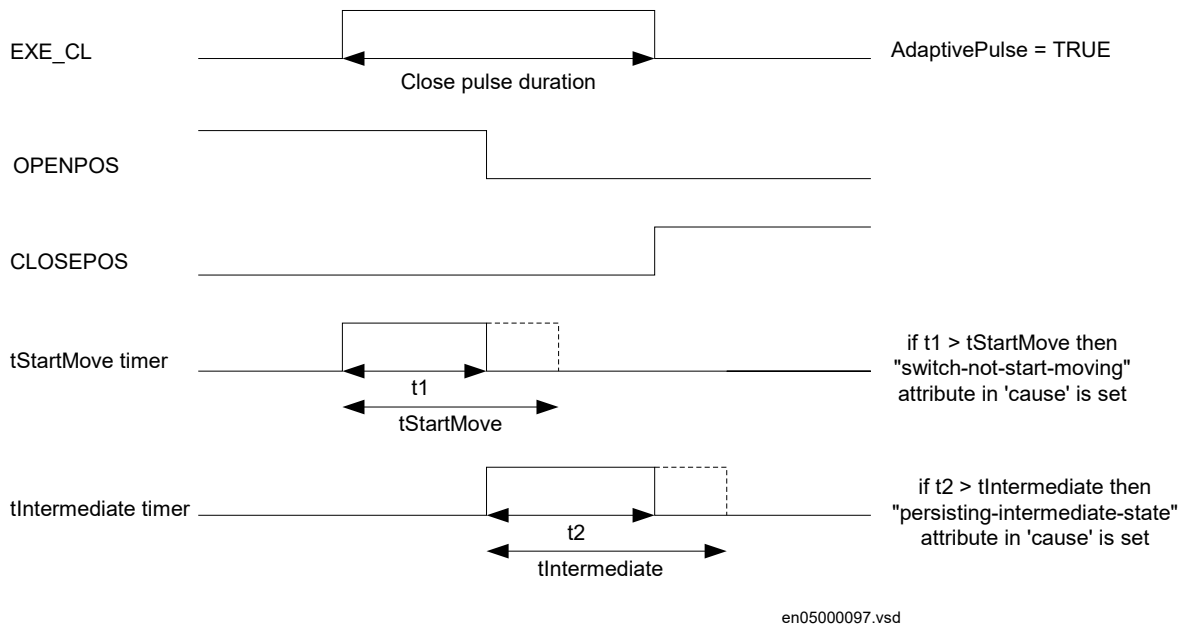

Figure 125: The timers $t_{StartMove}$ and $t_{Intermediate}$

The timers $t_{OpenPulse}$ and $t_{ClosePulse}$ are the length of the execute output pulses to be sent to the primary equipment. Note that the output pulses for open and close command can have different pulse lengths. The pulses can also be set to be adaptive with the configuration parameter *AdaptivePulse*. Figure 126 shows the principle of the execute output pulse. The *AdaptivePulse* parameter will have affect on both execute output pulses.

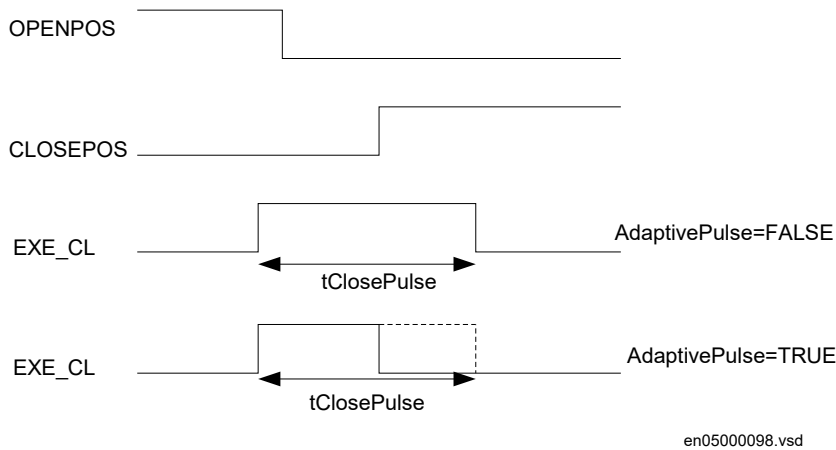

Figure 126: Execute output pulse

If the pulse is set to be adaptive, it is not possible for the pulse to exceed *tOpenPulse* or *tClosePulse*.

The execute output pulses are reset when:

- the new expected final position is reached and the configuration parameter *AdaptivePulse* is set to true
- the timer *tOpenPulse* or *tClosePulse* has elapsed
- an error occurs due to the switch does not start moving, that is, *tStartMove* has elapsed.

There is one exception from the first item above. If the primary device is in open position and an open command is executed or if the primary device is in close position and a close command is executed. In these cases, with the additional condition that the configuration parameter *AdaptivePulse* is true, the execute output pulse is always activated and resets when *tStartMove* has elapsed. If the configuration parameter *AdaptivePulse* is set to false the execution output remains active until the pulse duration timer has elapsed.



If the start position indicates bad state (OPENPOS=1 and CLOSEPOS =1) when a command is executed the execute output pulse resets only when timer *tOpenPulse* or *tClosePulse* has elapsed.

An example when a primary device is open and an open command is executed is shown in figure [127](#).

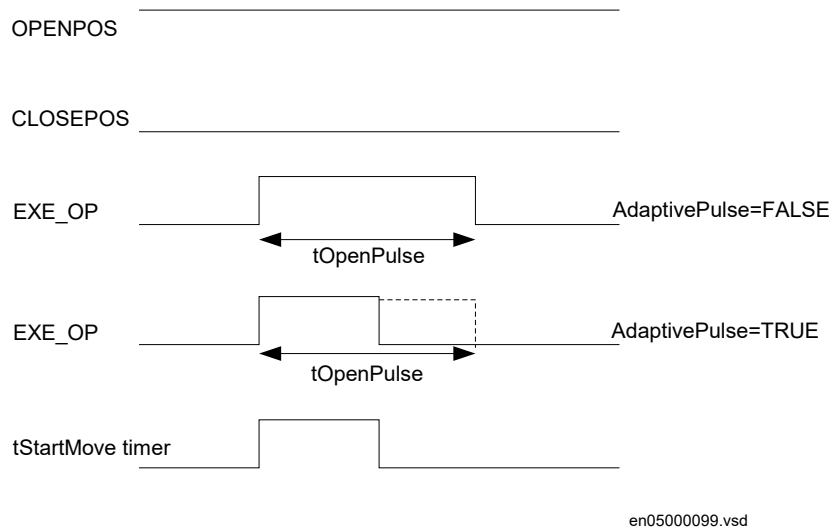

Figure 127: Open command with open position indication

Error handling

Depending on the error that occurs during the command sequence the error signal will be set with a value. Table 197 describes vendor specific cause values in addition to those specified in IEC 61850-8-1 standard. The list of values of the “cause” are in order of priority. The values are available over the IEC 61850. An output L_CAUSE on the function block indicates the latest value of the error during the command.

Table 197: Values for “cause” signal in priority order

Apparatus control function	Description
-22	wrongCTLModel
-23	blockedForCommand
-24	blocked-for-open-command
-25	blocked-for-close-command
-30	longOperationTime
-31	switch-not-start-moving
-32	persistent-intermediate-state
-33	switch-returned-to-initial-position
-34	switch-in-bad-state
-35	not-expected-final-position

10.3.9.4 Bay control QCBAY

The functionality of the Bay control (QCBAY) function is not defined in the IEC 61850-8-1 standard, which means that the function is a vendor specific logical node.

The function sends information about the Permitted Source To Operate (PSTO) and blocking conditions to other functions within the bay for example, switch control functions, voltage control functions and measurement functions.

Local panel switch

The local panel switch is a switch that defines the operator place selection. The switch connected to this function can have three positions remote/local/off. The positions are here

defined so that remote means that operation is allowed from station/remote level and local from the IED level. The local/remote switch is also on the control/protection IED itself, which means that the position of the switch and its validity information are connected internally, and not via I/O boards. When the switch is mounted separately from the IED the signals are connected to the function via I/O boards.

When the local panel switch (or LHMI selection, depending on the set source to select this) is in Off position, all commands from remote and local level will be ignored. If the position for the local/remote switch is not valid the PSTO output will always be set to faulty state (3), which means no possibility to operate.

To adapt the signals from the local HMI or from an external local/remote switch, the function blocks LOCREM and LOCREMCTRL are needed and connected to QCBAY.

Permitted Source To Operate (PSTO)

The actual state of the operator place is presented by the value of the Permitted Source To Operate, PSTO signal. The PSTO value is evaluated from the local/remote switch position according to table 198. In addition, there is one setting parameter that affects the value of the PSTO signal. If the parameter *AllPSTOValid* is set and LR-switch position is in Local or Remote state, the PSTO value is set to 5 (all), that is, it is permitted to operate from both local and remote level without any priority. When the external panel switch is in Off position the PSTO value shows the actual state of switch that is, 0. In this case it is not possible to control anything.

Table 198: PSTO values for different Local panel switch positions

Local panel switch positions	PSTO value	AllPSTOValid (setting parameter)	Possible locations that shall be able to operate
0 = Off	0	--	Not possible to operate
1 = Local	1	Priority	Local Panel
1 = Local	5	No priority	Local or Remote level without any priority
2 = Remote	2	Priority	Remote level
2 = Remote	5	No priority	Local or Remote level without any priority
3 = Faulty	3	--	Not possible to operate

Blockings

The blocking states for position indications and commands are intended to provide the possibility for the user to make common blockings for the functions configured within a complete bay.

The blocking facilities provided by the bay control function are the following:

- Blocking of position indications, BL_UPD. This input will block all inputs related to apparatus positions for all configured functions within the bay.
- Blocking of commands, BL_CMD. This input will block all commands for all configured functions within the bay.
- Blocking of function, BLOCK, signal from DO (Data Object) Behavior (IEC 61850–8–1). If DO Behavior is set to "blocked" it means that the function is active, but no outputs are generated, no reporting, control commands are rejected and functional and configuration data is visible.

The switching of the Local/Remote switch requires at least system operator level. The password will be requested at an attempt to operate if authority levels have been defined in

the IED. Otherwise the default authority level, SuperUser, can handle the control without LogOn. The users and passwords are defined in PCM600.

10.3.9.5 Local remote/Local remote control LOCREM/LOCREMCTRL

The function block Local remote (LOCREM) handles the signals coming from the local/remote switch. The connections are seen in figure 128, where the inputs on function block LOCREM are connected to binary inputs if an external switch is used. When the local HMI is used, the inputs are not used and are set to FALSE in the configuration. The outputs from the LOCREM function block control the output PSTO (Permitted Source To Operate) on Bay control (QCBAY).

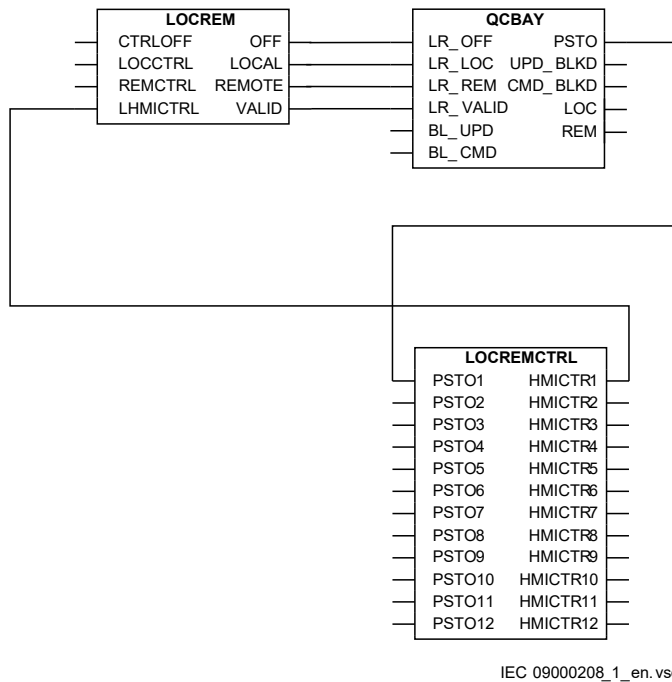

Figure 128: Configuration for the local/remote handling for a local HMI with one bay and one screen page

The switching of the local/remote switch requires at least system operator level. The password will be requested at an attempt to operate if authority levels have been defined in the IED. Otherwise the default authority level, SuperUser, can handle the control without LogOn. The users and passwords are defined in PCM600.

10.4 Interlocking

10.4.1 Functionality

The interlocking functionality blocks the possibility to operate high-voltage switching devices, for instance when a disconnecter is under load, in order to prevent material damage and/or accidental human injury.

Each control IED has interlocking functions for different switchyard arrangements, each handling the interlocking of one bay. The interlocking functionality in each IED is not dependent on any central function. For the station-wide interlocking, the IEDs communicate via the station bus or by using hard wired binary inputs/outputs.

The interlocking conditions depend on the primary bus configuration and status of any breaker or switch at any given time.

10.4.2 Logical node for interlocking SCILO

10.4.2.1 Identification

Function description	IEC 61850 identification	IEC 60617 identification	ANSI/IEEE C37.2 device number
Logical node for interlocking	SCILO	-	3

10.4.2.2 Functionality

The Logical node for interlocking SCILO function is used to enable a switching operation if the interlocking conditions permit. SCILO function itself does not provide any interlocking functionality. The interlocking conditions are generated in separate function blocks containing the interlocking logic and provides SCILO its input.

10.4.2.3 Function block

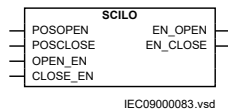

Figure 129: SCILO function block

10.4.2.4 Logic diagram

The function contains logic to enable the open and close commands respectively if the interlocking conditions are fulfilled. That means also, if the switch being controlled has its position defined as open (via POSOPEN) for example, then the appropriate enable signal output (in this case EN_OPEN) is false. The switch operation enable signals EN_OPEN and EN_CLOSE can be true at the same time only in the intermediate and bad position state of the switch (defined via POSOPEN and POSCLOSE) and if they are enabled by the interlocking function. The position inputs come from the logical nodes Circuit breaker/Circuit switch (SXCBR/SXSWI) and the enable signals, OPEN_EN and CLOSE_EN come from the interlocking logic. The outputs are connected to the logical node Switch controller (SCSWI). One instance per switching device is needed.

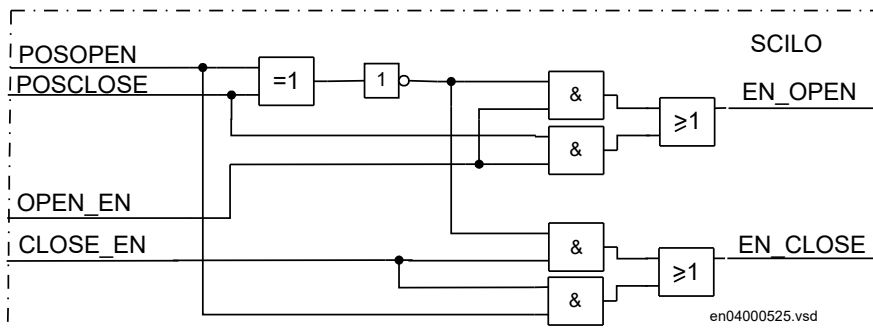

Figure 130: SCILO function logic diagram

10.4.2.5 Signals

Table 199: SCILO Input signals

Name	Type	Default	Description
POSOPEN	BOOLEAN	0	Open position of switch device
POSCLOSE	BOOLEAN	0	Closed position of switch device
OPEN_EN	BOOLEAN	0	Open operation from interlocking logic is enabled
CLOSE_EN	BOOLEAN	0	Close operation from interlocking logic is enabled

Table 200: SCILO Output signals

Name	Type	Description
EN_OPEN	BOOLEAN	Open operation at closed or intermediate or bad position is enabled
EN_CLOSE	BOOLEAN	Close operation at open or intermediate or bad position is enabled

10.4.2.6 Settings

The function does not have any settings available in Local HMI or Protection and Control IED Manager (PCM600).

10.4.3 Interlocking for busbar earthing switch BB_ES

10.4.3.1 Identification

Function description	IEC 61850 identification	IEC 60617 identification	ANSI/IEEE C37.2 device number
Interlocking for busbar earthing switch	BB_ES	-	3

10.4.3.2 Functionality

The interlocking for busbar earthing switch (BB_ES) function is used for one busbar earthing switch on any busbar parts according to figure [131](#).

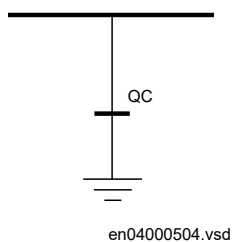

Figure 131: Switchyard layout BB_ES

10.4.3.3 Function block

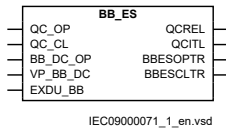
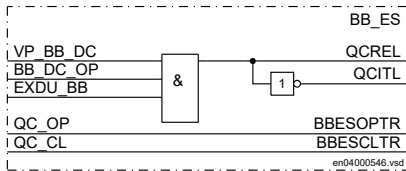

Figure 132: BB_ES function block

10.4.3.4 Logic diagram



10.4.3.5 Signals

Table 201: BB_ES Input signals

Name	Type	Default	Description
QC_OP	BOOLEAN	0	Busbar earthing switch QC is in open position
QC_CL	BOOLEAN	0	Busbar earthing switch QC is in closed position
BB_DC_OP	BOOLEAN	0	All disconnectors on this busbar part are open
VP_BB_DC	BOOLEAN	0	Status for all disconnectors on this busbar part are valid
EXDU_BB	BOOLEAN	0	No transmission error from any bay containing all disconnectors on this busbar part

Table 202: BB_ES Output signals

Name	Type	Description
QCREL	BOOLEAN	Switching of QC is allowed
QCITL	BOOLEAN	Switching of QC is forbidden
BBESOPTR	BOOLEAN	QC on this busbar part is in open position
BBESCLTR	BOOLEAN	QC on this busbar part is in closed position

10.4.3.6 Settings

The function does not have any settings available in Local HMI or Protection and Control IED Manager (PCM600).

10.4.4 Interlocking for bus-section breaker A1A2_BS

10.4.4.1 Identification

Function description	IEC 61850 identification	IEC 60617 identification	ANSI/IEEE C37.2 device number
Interlocking for bus-section breaker	A1A2_BS	-	3

10.4.4.2 Functionality

The interlocking for bus-section breaker (A1A2_BS) function is used for one bus-section circuit breaker between section 1 and 2 according to figure 133. The function can be used for different busbars, which includes a bus-section circuit breaker.

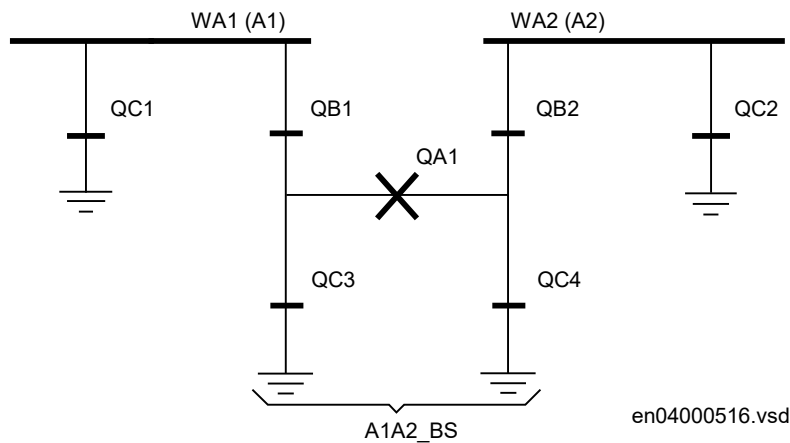

Figure 133: Switchyard layout A1A2_BS

10.4.4.3 Function block

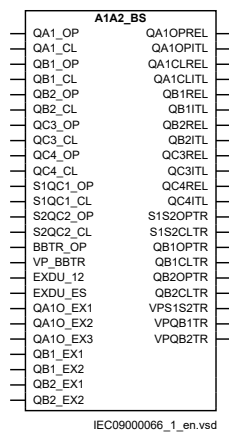
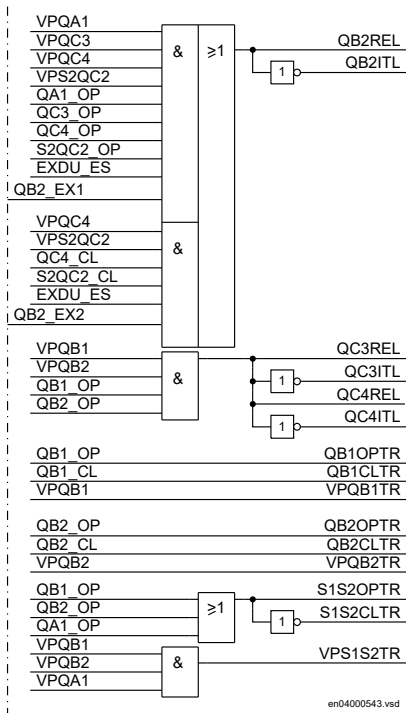
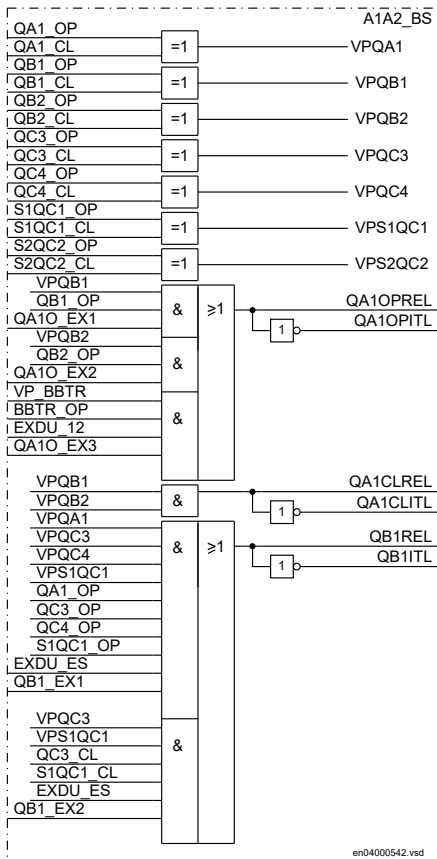

Figure 134: A1A2_BS function block

10.4.4.4 Logic diagram



10.4.4.5 Signals

Table 203: A1A2_BS Input signals

Name	Type	Default	Description
QA1_OP	BOOLEAN	0	QA1 is in open position
QA1_CL	BOOLEAN	0	QA1 is in closed position
QB1_OP	BOOLEAN	0	QB1 is in open position
QB1_CL	BOOLEAN	0	QB1 is in closed position
QB2_OP	BOOLEAN	0	QB2 is in open position
QB2_CL	BOOLEAN	0	QB2 is in closed position
QC3_OP	BOOLEAN	0	QC3 is in open position
QC3_CL	BOOLEAN	0	QC3 is in closed position
QC4_OP	BOOLEAN	0	QC4 is in open position
QC4_CL	BOOLEAN	0	QC4 is in closed position
S1QC1_OP	BOOLEAN	0	QC1 on bus section 1 is in open position
S1QC1_CL	BOOLEAN	0	QC1 on bus section 1 is in closed position
S2QC2_OP	BOOLEAN	0	QC2 on bus section 2 is in open position
S2QC2_CL	BOOLEAN	0	QC2 on bus section 2 is in closed position
BBTR_OP	BOOLEAN	0	No busbar transfer is in progress
VP_BBTR	BOOLEAN	0	Status are valid for apparatuses involved in the busbar transfer
EXDU_12	BOOLEAN	0	No transmission error from any bay connected to busbar 1 and 2
EXDU_ES	BOOLEAN	0	No transmission error from bays containing earthing switches QC1 or QC2
QA10_EX1	BOOLEAN	0	External open condition for apparatus QA1
QA10_EX2	BOOLEAN	0	External open condition for apparatus QA1
QA10_EX3	BOOLEAN	0	External open condition for apparatus QA1
QB1_EX1	BOOLEAN	0	External condition for apparatus QB1
QB1_EX2	BOOLEAN	0	External condition for apparatus QB1
QB2_EX1	BOOLEAN	0	External condition for apparatus QB2
QB2_EX2	BOOLEAN	0	External condition for apparatus QB2

Table 204: A1A2_BS Output signals

Name	Type	Description
QA1OPREL	BOOLEAN	Opening of QA1 is allowed
QA1OPITL	BOOLEAN	Opening of QA1 is forbidden
QA1CLREL	BOOLEAN	Closing of QA1 is allowed
QA1CLITL	BOOLEAN	Closing of QA1 is forbidden
QB1REL	BOOLEAN	Switching of QB1 is allowed
QB1ITL	BOOLEAN	Switching of QB1 is forbidden
QB2REL	BOOLEAN	Switching of QB2 is allowed
QB2ITL	BOOLEAN	Switching of QB2 is forbidden

Table continues on next page

Name	Type	Description
QC3REL	BOOLEAN	Switching of QC3 is allowed
QC3ITL	BOOLEAN	Switching of QC3 is forbidden
QC4REL	BOOLEAN	Switching of QC4 is allowed
QC4ITL	BOOLEAN	Switching of QC4 is forbidden
S1S2OPTR	BOOLEAN	No bus section connection between bus section 1 and 2
S1S2CLTR	BOOLEAN	Bus coupler connection between bus section 1 and 2 exists
QB1OPTR	BOOLEAN	QB1 is in open position
QB1CLTR	BOOLEAN	QB1 is in closed position
QB2OPTR	BOOLEAN	QB2 is in open position
QB2CLTR	BOOLEAN	QB2 is in closed position
VPS1S2TR	BOOLEAN	Status of the apparatuses between bus section 1 and 2 are valid
VPQB1TR	BOOLEAN	Switch status of QB1 is valid (open or closed)
VPQB2TR	BOOLEAN	Switch status of QB2 is valid (open or closed)

10.4.4.6 Settings

The function does not have any settings available in Local HMI or Protection and Control IED Manager (PCM600).

10.4.5 Interlocking for bus-section disconnecter A1A2_DC

10.4.5.1 Identification

Function description	IEC 61850 identification	IEC 60617 identification	ANSI/IEEE C37.2 device number
Interlocking for bus-section disconnecter	A1A2_DC	-	3

10.4.5.2 Functionality

The interlocking for bus-section disconnecter (A1A2_DC) function is used for one bus-section disconnecter between section 1 and 2 according to figure [135](#). A1A2_DC function can be used for different busbars, which includes a bus-section disconnecter.

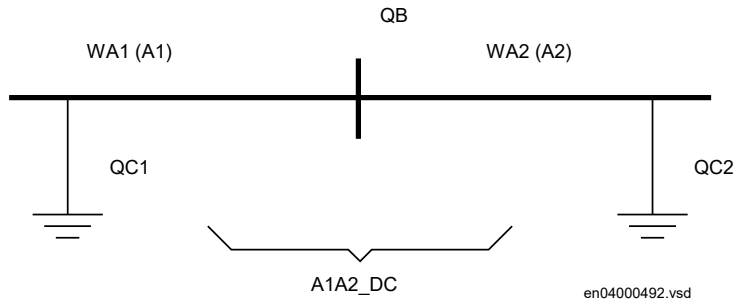

Figure 135: Switchyard layout A1A2_DC

10.4.5.3 Function block

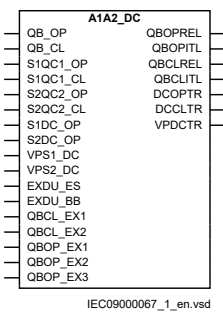
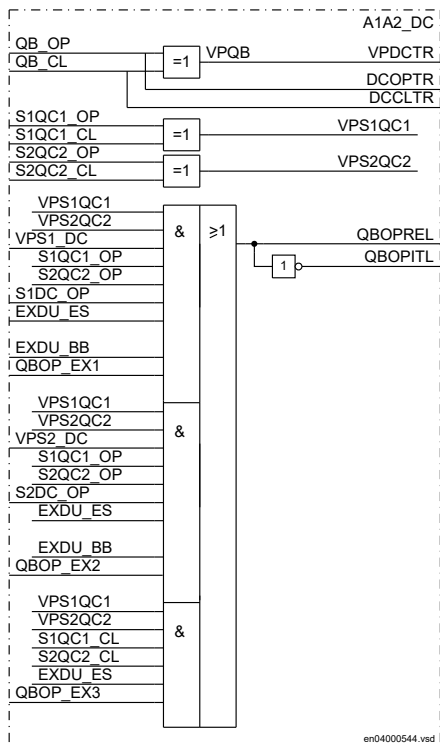

Figure 136: A1A2_DC function block

10.4.5.4 Logic diagram



10.4.5.5 Signals

Table 205: A1A2_DC Input signals

Name	Type	Default	Description
QB_OP	BOOLEAN	0	QB is in open position
QB_CL	BOOLEAN	0	QB is in closed position
S1QC1_OP	BOOLEAN	0	QC1 on bus section 1 is in open position
S1QC1_CL	BOOLEAN	0	QC1 on bus section 1 is in closed position
S2QC2_OP	BOOLEAN	0	QC2 on bus section 2 is in open position
S2QC2_CL	BOOLEAN	0	QC2 on bus section 2 is in closed position
S1DC_OP	BOOLEAN	0	All disconnectors on bus section 1 are in open position
S2DC_OP	BOOLEAN	0	All disconnectors on bus section 2 are in open position
VPS1_DC	BOOLEAN	0	Switch status of disconnectors on bus section 1 are valid
VPS2_DC	BOOLEAN	0	Switch status of disconnectors on bus section 2 are valid
EXDU_ES	BOOLEAN	0	No transmission error from bays containing earthing switches QC1 or QC2
EXDU_BB	BOOLEAN	0	No transmission error from bays with disconnectors connected to sections 1 and 2
QBCL_EX1	BOOLEAN	0	External close condition for section disconnector QB
QBCL_EX2	BOOLEAN	0	External close condition for section disconnector QB
QBOP_EX1	BOOLEAN	0	External open condition for section disconnector QB
QBOP_EX2	BOOLEAN	0	External open condition for section disconnector QB
QBOP_EX3	BOOLEAN	0	External open condition for section disconnector QB

Table 206: A1A2_DC Output signals

Name	Type	Description
QBOPREL	BOOLEAN	Opening of QB is allowed
QBOPITL	BOOLEAN	Opening of QB is forbidden
QBCLREL	BOOLEAN	Closing of QB is allowed
QBCLITL	BOOLEAN	Closing of QB is forbidden
DCOPTR	BOOLEAN	The bus section disconnector is in open position
DCCLTR	BOOLEAN	The bus section disconnector is in closed position
VPDCTR	BOOLEAN	Switch status of QB is valid (open or closed)

10.4.5.6 Settings

The function does not have any settings available in Local HMI or Protection and Control IED Manager (PCM600).

10.4.6 Interlocking for bus-coupler bay ABC_BC

10.4.6.1 Identification

Function description	IEC 61850 identification	IEC 60617 identification	ANSI/IEEE C37.2 device number
Interlocking for bus-coupler bay	ABC_BC	-	3

10.4.6.2 Functionality

The interlocking for bus-coupler bay (ABC_BC) function is used for a bus-coupler bay connected to a double busbar arrangement according to figure 137. The function can also be used for a single busbar arrangement with transfer busbar or double busbar arrangement without transfer busbar.

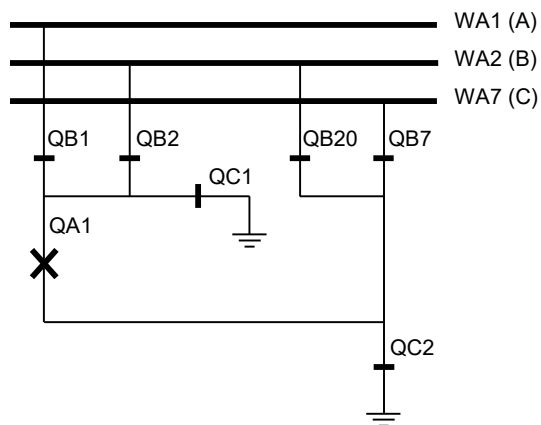

en04000514.vsd

Figure 137: Switchyard layout ABC_BC



The interlocking functionality in 650 series can not handle the transfer bus (WA7)C.

10.4.6.3 Function block

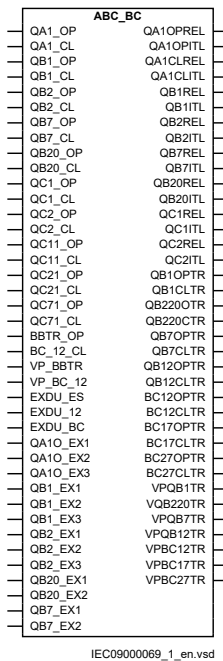
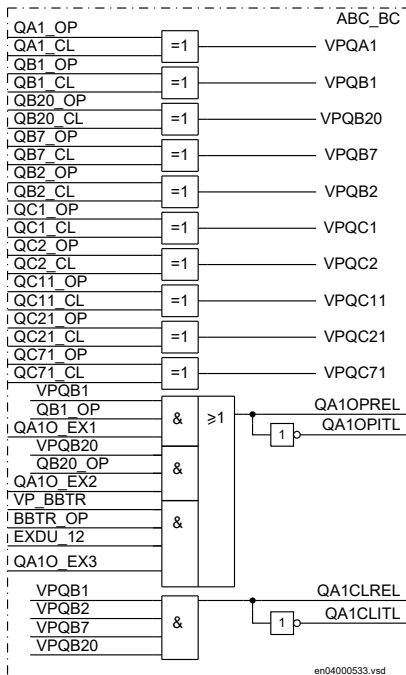
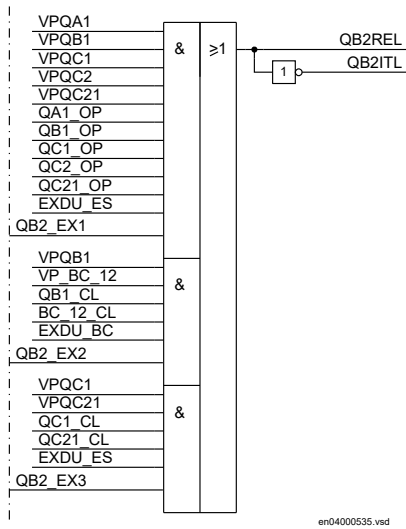
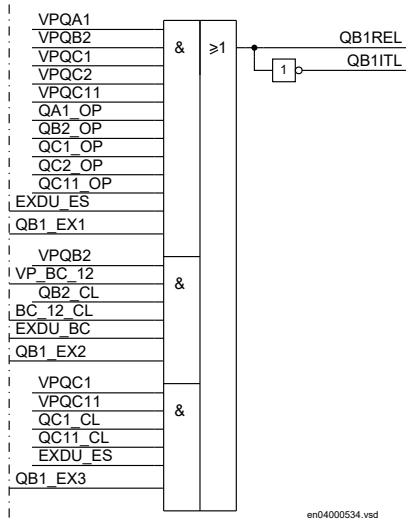
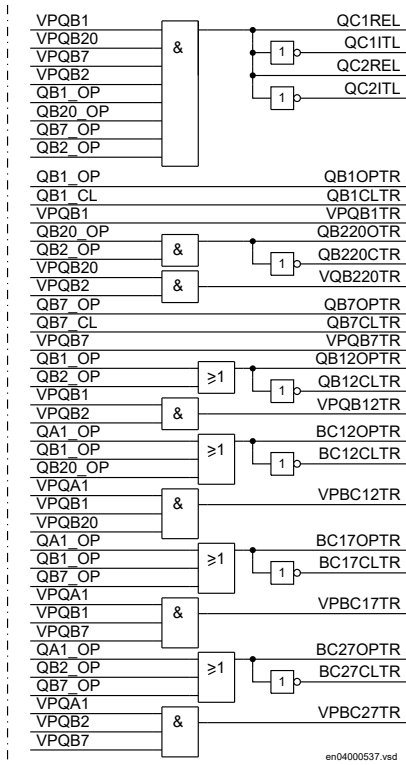
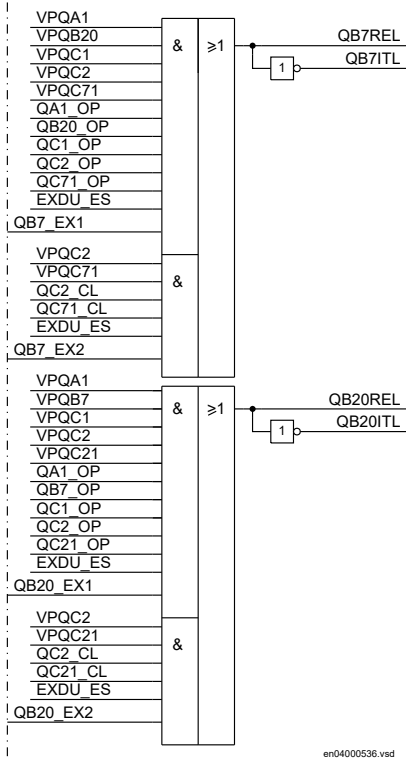

Figure 138: ABC_BC function block

10.4.6.4 Logic diagram







10.4.6.5 Signals

Table 207: ABC_BC Input signals

Name	Type	Default	Description
QA1_OP	BOOLEAN	0	QA1 is in open position
QA1_CL	BOOLEAN	0	QA1 is in closed position
QB1_OP	BOOLEAN	0	QB1 is in open position
QB1_CL	BOOLEAN	0	QB1 is in closed position
QB2_OP	BOOLEAN	0	QB2 is in open position
QB2_CL	BOOLEAN	0	QB2 is in closed position
QB7_OP	BOOLEAN	0	QB7 is in open position
QB7_CL	BOOLEAN	0	QB7 is in closed position
QB20_OP	BOOLEAN	0	QB20 is in open position
QB20_CL	BOOLEAN	0	QB20 is in closed position
QC1_OP	BOOLEAN	0	QC1 is in open position
QC1_CL	BOOLEAN	0	QC1 is in closed position
QC2_OP	BOOLEAN	0	QC2 is in open position
QC2_CL	BOOLEAN	0	QC2 is in closed position
QC11_OP	BOOLEAN	0	Earthing switch QC11 on busbar WA1 is in open position
QC11_CL	BOOLEAN	0	Earthing switch QC11 on busbar WA1 is in closed position
QC21_OP	BOOLEAN	0	Earthing switch QC21 on busbar WA2 is in open position
QC21_CL	BOOLEAN	0	Earthing switch QC21 on busbar WA2 is in closed position
QC71_OP	BOOLEAN	0	Earthing switch QC71 on busbar WA7 is in open position
QC71_CL	BOOLEAN	0	Earthing switch QC71 on busbar WA7 is in closed position
BBTR_OP	BOOLEAN	0	No busbar transfer is in progress
BC_12_CL	BOOLEAN	0	Bus coupler connection exists between busbar WA1 and WA2
VP_BBTR	BOOLEAN	0	Status are valid for apparatuses involved in the busbar transfer
VP_BC_12	BOOLEAN	0	Status of the bus coupler apparatuses between WA1 and WA2 are valid
EXDU_ES	BOOLEAN	0	No transmission error from any bay containing earthing switches
EXDU_12	BOOLEAN	0	No transmission error from any bay connected to WA1/WA2 busbars
EXDU_BC	BOOLEAN	0	No transmission error from any other bus coupler bay
QA10_EX1	BOOLEAN	0	External open condition for apparatus QA1
QA10_EX2	BOOLEAN	0	External open condition for apparatus QA1
QA10_EX3	BOOLEAN	0	External open condition for apparatus QA1
QB1_EX1	BOOLEAN	0	External condition for apparatus QB1
QB1_EX2	BOOLEAN	0	External condition for apparatus QB1
QB1_EX3	BOOLEAN	0	External condition for apparatus QB1
QB2_EX1	BOOLEAN	0	External condition for apparatus QB2
QB2_EX2	BOOLEAN	0	External condition for apparatus QB2
QB2_EX3	BOOLEAN	0	External condition for apparatus QB2

Table continues on next page

Name	Type	Default	Description
QB20_EX1	BOOLEAN	0	External condition for apparatus QB20
QB20_EX2	BOOLEAN	0	External condition for apparatus QB20
QB7_EX1	BOOLEAN	0	External condition for apparatus QB7
QB7_EX2	BOOLEAN	0	External condition for apparatus QB7

Table 208: ABC_BC Output signals

Name	Type	Description
QA1OPREL	BOOLEAN	Opening of QA1 is allowed
QA1OPITL	BOOLEAN	Opening of QA1 is forbidden
QA1CLREL	BOOLEAN	Closing of QA1 is allowed
QA1CLITL	BOOLEAN	Closing of QA1 is forbidden
QB1REL	BOOLEAN	Switching of QB1 is allowed
QB1ITL	BOOLEAN	Switching of QB1 is forbidden
QB2REL	BOOLEAN	Switching of QB2 is allowed
QB2ITL	BOOLEAN	Switching of QB2 is forbidden
QB7REL	BOOLEAN	Switching of QB7 is allowed
QB7ITL	BOOLEAN	Switching of QB7 is forbidden
QB20REL	BOOLEAN	Switching of QB20 is allowed
QB20ITL	BOOLEAN	Switching of QB20 is forbidden
QC1REL	BOOLEAN	Switching of QC1 is allowed
QC1ITL	BOOLEAN	Switching of QC1 is forbidden
QC2REL	BOOLEAN	Switching of QC2 is allowed
QC2ITL	BOOLEAN	Switching of QC2 is forbidden
QB1OPTR	BOOLEAN	QB1 is in open position
QB1CLTR	BOOLEAN	QB1 is in closed position
QB220OTR	BOOLEAN	QB2 and QB20 are in open position
QB220CTR	BOOLEAN	QB2 or QB20 or both are not in open position
QB7OPTR	BOOLEAN	QB7 is in open position
QB7CLTR	BOOLEAN	QB7 is in closed position
QB12OPTR	BOOLEAN	QB1 or QB2 or both are in open position
QB12CLTR	BOOLEAN	QB1 and QB2 are not in open position
BC12OPTR	BOOLEAN	No connection via the own bus coupler between WA1 and WA2
BC12CLTR	BOOLEAN	Connection exists via the own bus coupler between WA1 and WA2
BC17OPTR	BOOLEAN	No connection via the own bus coupler between WA1 and WA7
BC17CLTR	BOOLEAN	Connection exists via the own bus coupler between WA1 and WA7
BC27OPTR	BOOLEAN	No connection via the own bus coupler between WA2 and WA7
BC27CLTR	BOOLEAN	Connection exists via the own bus coupler between WA2 and WA7
VPQB1TR	BOOLEAN	Switch status of QB1 is valid (open or closed)
Table continues on next page		

Name	Type	Description
VQB220TR	BOOLEAN	Switch status of QB2 and QB20 are valid (open or closed)
VPQB7TR	BOOLEAN	Switch status of QB7 is valid (open or closed)
VPQB12TR	BOOLEAN	Switch status of QB1 and QB2 are valid (open or closed)
VPBC12TR	BOOLEAN	Status of the bus coupler apparatuses between WA1 and WA2 are valid
VPBC17TR	BOOLEAN	Status of the bus coupler apparatuses between WA1 and WA7 are valid
VPBC27TR	BOOLEAN	Status of the bus coupler apparatuses between WA2 and WA7 are valid

10.4.6.6 Settings

The function does not have any settings available in Local HMI or Protection and Control IED Manager (PCM600).

10.4.7 Interlocking for 1 1/2 CB BH

10.4.7.1 Identification

Function description	IEC 61850 identification	IEC 60617 identification	ANSI/IEEE C37.2 device number
Interlocking for 1 1/2 breaker diameter	BH_CONN	-	3
Interlocking for 1 1/2 breaker diameter	BH_LINE_A	-	3
Interlocking for 1 1/2 breaker diameter	BH_LINE_B	-	3

10.4.7.2 Functionality

The interlocking for 1 1/2 breaker diameter (BH_CONN, BH_LINE_A, BH_LINE_B) functions are used for lines connected to a 1 1/2 breaker diameter according to figure [139](#).

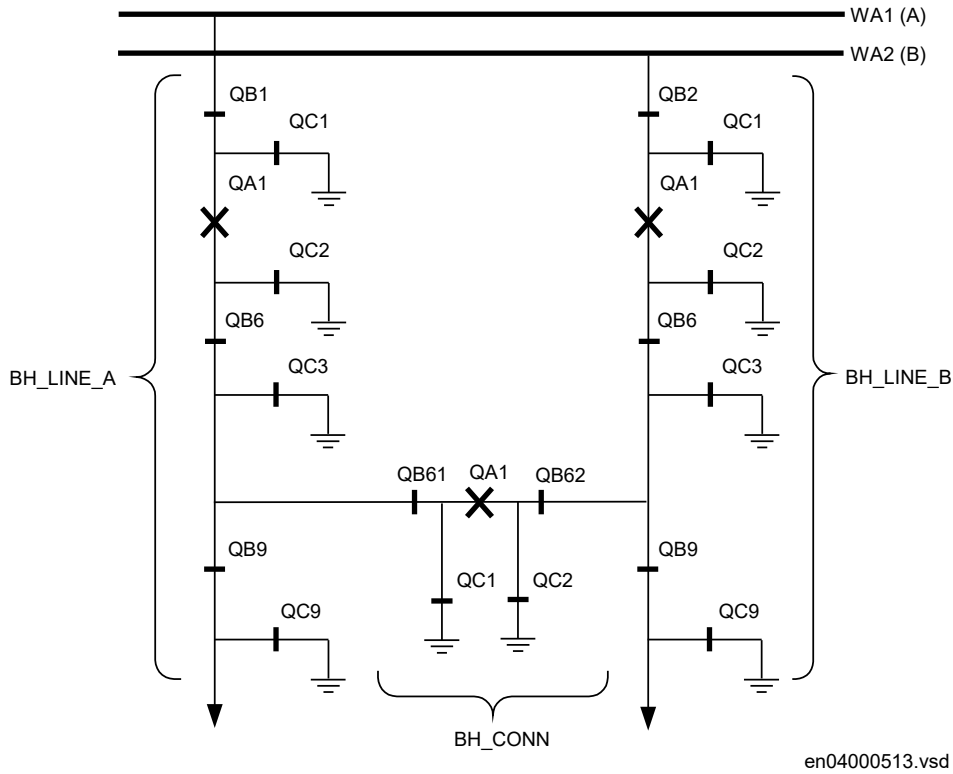

Figure 139: Switchyard layout 1 1/2 breaker

Three types of interlocking modules per diameter are defined. BH_LINE_A and BH_LINE_B are the connections from a line to a busbar. BH_CONN is the connection between the two lines of the diameter in the 1 1/2 breaker switchyard layout.

10.4.7.3 Function block

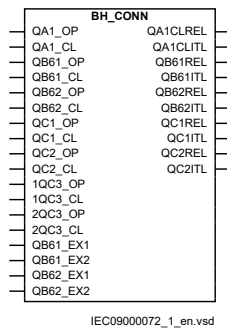

Figure 140: BH_CONN function block

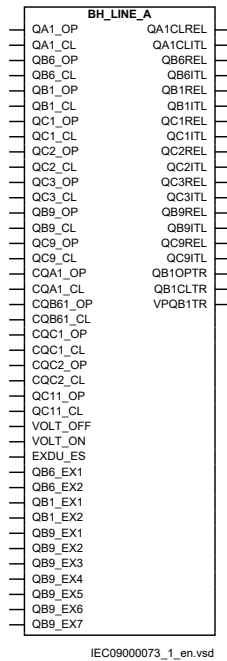

Figure 141: BH_LINE_A function block

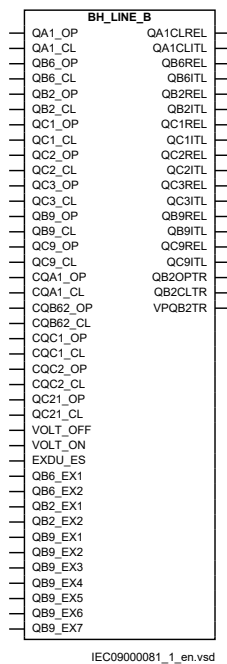
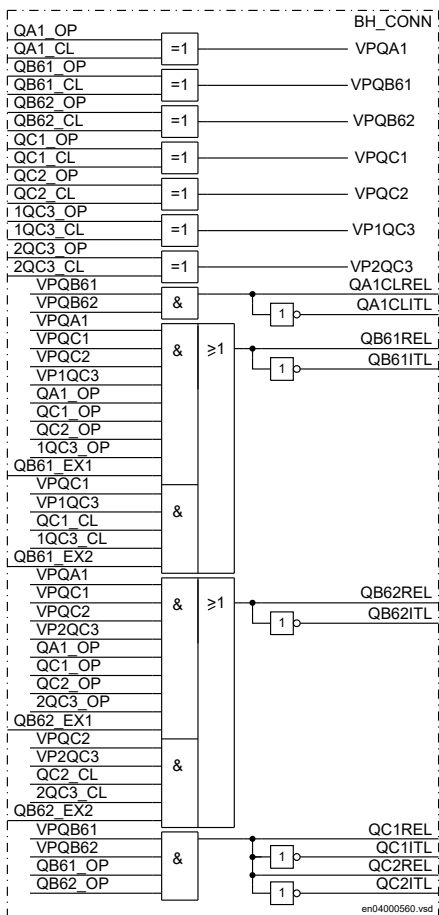
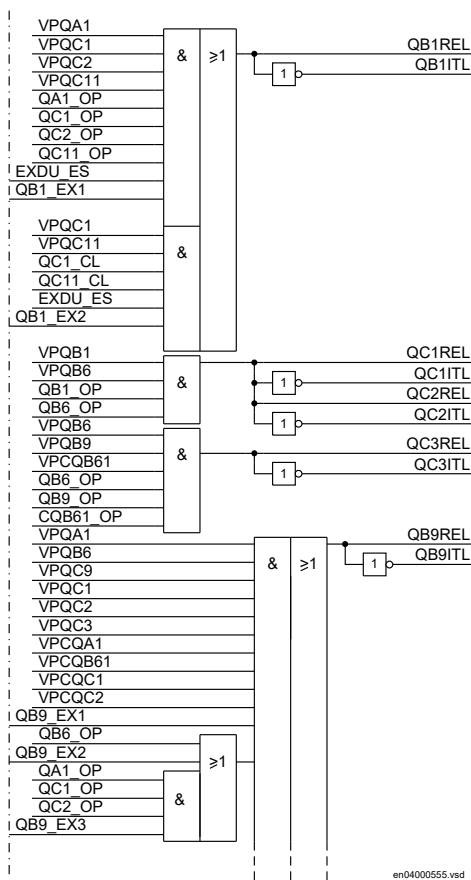
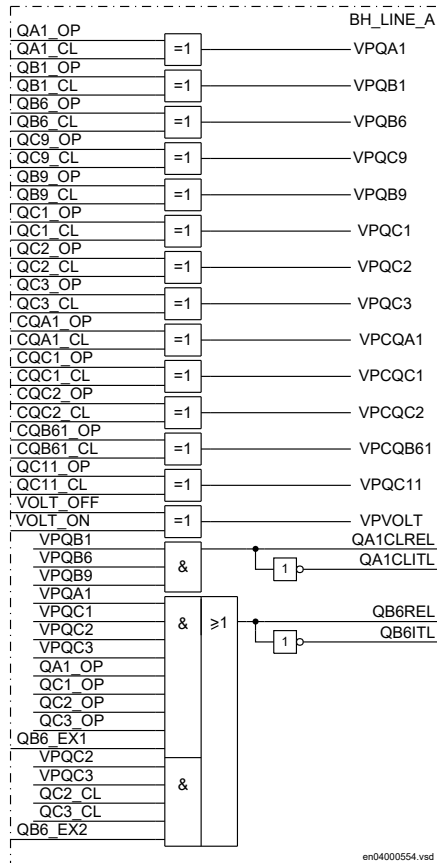
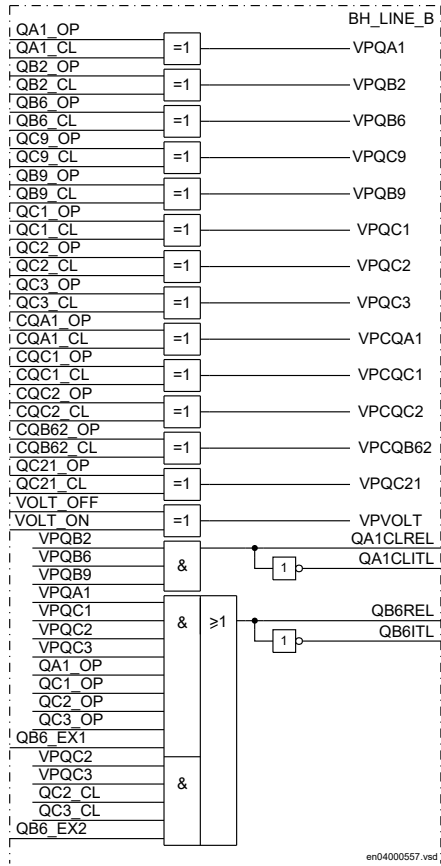
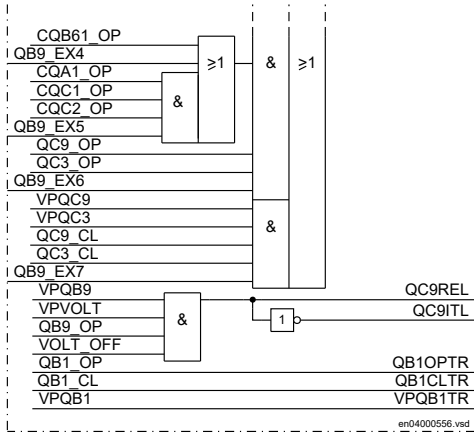

Figure 142: BH_LINE_B function block

10.4.7.4 Logic diagrams







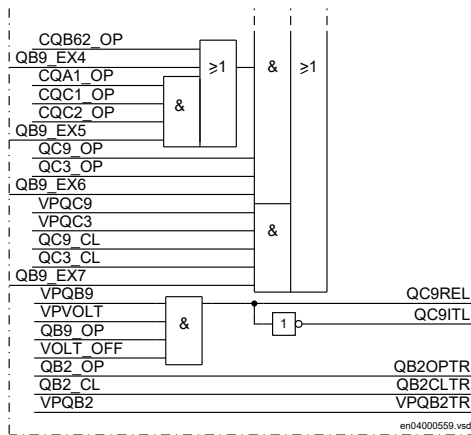
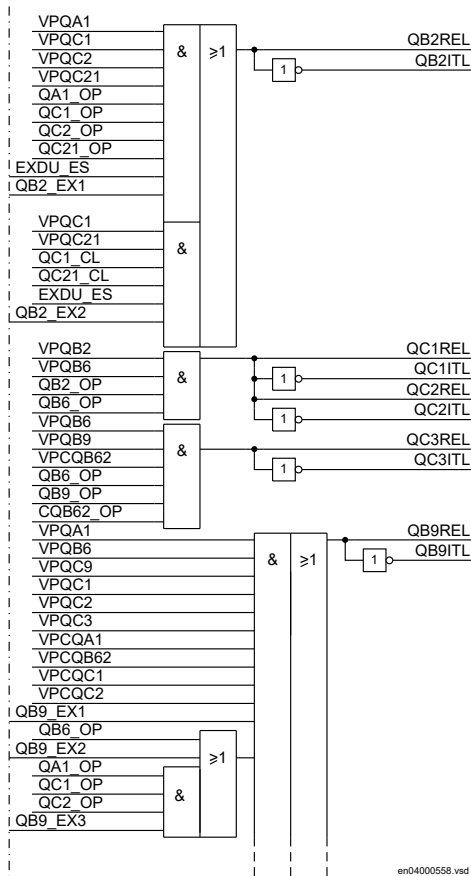

10.4.7.5 Signals

Table 209: BH_CONN Input signals

Name	Type	Default	Description
QA1_OP	BOOLEAN	0	QA1 is in open position
QA1_CL	BOOLEAN	0	QA1 is in closed position
QB61_OP	BOOLEAN	0	QB61 is in open position
QB61_CL	BOOLEAN	0	QB61 is in closed position
QB62_OP	BOOLEAN	0	QB62 is in open position

Table continues on next page

Name	Type	Default	Description
QB62_CL	BOOLEAN	0	QB62 is in closed position
QC1_OP	BOOLEAN	0	QC1 is in open position
QC1_CL	BOOLEAN	0	QC1 is in closed position
QC2_OP	BOOLEAN	0	QC2 is in open position
QC2_CL	BOOLEAN	0	QC2 is in closed position
1QC3_OP	BOOLEAN	0	QC3 on line 1 is in open position
1QC3_CL	BOOLEAN	0	QC3 on line 1 is in closed position
2QC3_OP	BOOLEAN	0	QC3 on line 2 is in open position
2QC3_CL	BOOLEAN	0	QC3 on line 2 is in closed position
QB61_EX1	BOOLEAN	0	External condition for apparatus QB61
QB61_EX2	BOOLEAN	0	External condition for apparatus QB61
QB62_EX1	BOOLEAN	0	External condition for apparatus QB62
QB62_EX2	BOOLEAN	0	External condition for apparatus QB62

Table 210: BH_LINE_A Input signals

Name	Type	Default	Description
QA1_OP	BOOLEAN	0	QA1 is in open position
QA1_CL	BOOLEAN	0	QA1 is in closed position
QB6_OP	BOOLEAN	0	QB6 is in open position
QB6_CL	BOOLEAN	0	QB6 is in close position
QB1_OP	BOOLEAN	0	QB1 is in open position
QB1_CL	BOOLEAN	0	QB1 is in closed position
QC1_OP	BOOLEAN	0	QC1 is in open position
QC1_CL	BOOLEAN	0	QC1 is in closed position
QC2_OP	BOOLEAN	0	QC2 is in open position
QC2_CL	BOOLEAN	0	QC2 is in closed position
QC3_OP	BOOLEAN	0	QC3 is in open position
QC3_CL	BOOLEAN	0	QC3 is in closed position
QB9_OP	BOOLEAN	0	QB9 is in open position
QB9_CL	BOOLEAN	0	QB9 is in closed position
QC9_OP	BOOLEAN	0	QC9 is in open position
QC9_CL	BOOLEAN	0	QC9 is in closed position
CQA1_OP	BOOLEAN	0	QA1 in module BH_CONN is in open position
CQA1_CL	BOOLEAN	0	QA1 in module BH_CONN is in closed position
CQB61_OP	BOOLEAN	0	QB61 in module BH_CONN is in open position
CQB61_CL	BOOLEAN	0	QB61 in module BH_CONN is in closed position
CQC1_OP	BOOLEAN	0	QC1 in module BH_CONN is in open position
CQC1_CL	BOOLEAN	0	QC1 in module BH_CONN is in closed position
CQC2_OP	BOOLEAN	0	QC2 in module BH_CONN is in open position
CQC2_CL	BOOLEAN	0	QC2 in module BH_CONN is in closed position
QC11_OP	BOOLEAN	0	Earthing switch QC11 on busbar WA1 is in open position

Table continues on next page

Name	Type	Default	Description
QC11_CL	BOOLEAN	0	Earthing switch QC11 on busbar WA1 is in closed position
VOLT_OFF	BOOLEAN	0	There is no voltage on line and not VT (fuse) failure
VOLT_ON	BOOLEAN	0	There is voltage on the line or there is a VT (fuse) failure
EXDU_ES	BOOLEAN	0	No transmission error from bay containing earthing switch QC11
QB6_EX1	BOOLEAN	0	External condition for apparatus QB6
QB6_EX2	BOOLEAN	0	External condition for apparatus QB6
QB1_EX1	BOOLEAN	0	External condition for apparatus QB1
QB1_EX2	BOOLEAN	0	External condition for apparatus QB1
QB9_EX1	BOOLEAN	0	External condition for apparatus QB9
QB9_EX2	BOOLEAN	0	External condition for apparatus QB9
QB9_EX3	BOOLEAN	0	External condition for apparatus QB9
QB9_EX4	BOOLEAN	0	External condition for apparatus QB9
QB9_EX5	BOOLEAN	0	External condition for apparatus QB9
QB9_EX6	BOOLEAN	0	External condition for apparatus QB9
QB9_EX7	BOOLEAN	0	External condition for apparatus QB9

Table 211: BH_LINE_B Input signals

Name	Type	Default	Description
QA1_OP	BOOLEAN	0	QA1 is in open position
QA1_CL	BOOLEAN	0	QA1 is in closed position
QB6_OP	BOOLEAN	0	QB6 is in open position
QB6_CL	BOOLEAN	0	QB6 is in close position
QB2_OP	BOOLEAN	0	QB2 is in open position
QB2_CL	BOOLEAN	0	QB2 is in closed position
QC1_OP	BOOLEAN	0	QC1 is in open position
QC1_CL	BOOLEAN	0	QC1 is in closed position
QC2_OP	BOOLEAN	0	QC2 is in open position
QC2_CL	BOOLEAN	0	QC2 is in closed position
QC3_OP	BOOLEAN	0	QC3 is in open position
QC3_CL	BOOLEAN	0	QC3 is in closed position
QB9_OP	BOOLEAN	0	QB9 is in open position
QB9_CL	BOOLEAN	0	QB9 is in closed position
QC9_OP	BOOLEAN	0	QC9 is in open position
QC9_CL	BOOLEAN	0	QC9 is in closed position
CQA1_OP	BOOLEAN	0	QA1 in module BH_CONN is in open position
CQA1_CL	BOOLEAN	0	QA1 in module BH_CONN is in closed position
CQB62_OP	BOOLEAN	0	QB62 in module BH_CONN is in open position
CQB62_CL	BOOLEAN	0	QB62 in module BH_CONN is in closed position
CQC1_OP	BOOLEAN	0	QC1 in module BH_CONN is in open position
CQC1_CL	BOOLEAN	0	QC1 in module BH_CONN is in closed position

Table continues on next page

Name	Type	Default	Description
CQC2_OP	BOOLEAN	0	QC2 in module BH_CONN is in open position
CQC2_CL	BOOLEAN	0	QC2 in module BH_CONN is in closed position
QC21_OP	BOOLEAN	0	Earthing switch QC21 on busbar WA2 is in open position
QC21_CL	BOOLEAN	0	Earthing switch QC21 on busbar WA2 is in closed position
VOLT_OFF	BOOLEAN	0	There is no voltage on line and not VT (fuse) failure
VOLT_ON	BOOLEAN	0	There is voltage on the line or there is a VT (fuse) failure
EXDU_ES	BOOLEAN	0	No transmission error from bay containing earthing switch QC21
QB6_EX1	BOOLEAN	0	External condition for apparatus QB6
QB6_EX2	BOOLEAN	0	External condition for apparatus QB6
QB2_EX1	BOOLEAN	0	External condition for apparatus QB2
QB2_EX2	BOOLEAN	0	External condition for apparatus QB2
QB9_EX1	BOOLEAN	0	External condition for apparatus QB9
QB9_EX2	BOOLEAN	0	External condition for apparatus QB9
QB9_EX3	BOOLEAN	0	External condition for apparatus QB9
QB9_EX4	BOOLEAN	0	External condition for apparatus QB9
QB9_EX5	BOOLEAN	0	External condition for apparatus QB9
QB9_EX6	BOOLEAN	0	External condition for apparatus QB9
QB9_EX7	BOOLEAN	0	External condition for apparatus QB9

Table 212: BH_CONN Output signals

Name	Type	Description
QA1CLREL	BOOLEAN	Closing of QA1 is allowed
QA1CLITL	BOOLEAN	Closing of QA1 is forbidden
QB61REL	BOOLEAN	Switching of QB61 is allowed
QB61ITL	BOOLEAN	Switching of QB61 is forbidden
QB62REL	BOOLEAN	Switching of QB62 is allowed
QB62ITL	BOOLEAN	Switching of QB62 is forbidden
QC1REL	BOOLEAN	Switching of QC1 is allowed
QC1ITL	BOOLEAN	Switching of QC1 is forbidden
QC2REL	BOOLEAN	Switching of QC2 is allowed
QC2ITL	BOOLEAN	Switching of QC2 is forbidden

Table 213: BH_LINE_A Output signals

Name	Type	Description
QA1CLREL	BOOLEAN	Closing of QA1 is allowed
QA1CLITL	BOOLEAN	Closing of QA1 is forbidden
QB6REL	BOOLEAN	Switching of QB6 is allowed
QB6ITL	BOOLEAN	Switching of QB6 is forbidden
QB1REL	BOOLEAN	Switching of QB1 is allowed
Table continues on next page		

Name	Type	Description
QB1ITL	BOOLEAN	Switching of QB1 is forbidden
QC1REL	BOOLEAN	Switching of QC1 is allowed
QC1ITL	BOOLEAN	Switching of QC1 is forbidden
QC2REL	BOOLEAN	Switching of QC2 is allowed
QC2ITL	BOOLEAN	Switching of QC2 is forbidden
QC3REL	BOOLEAN	Switching of QC3 is allowed
QC3ITL	BOOLEAN	Switching of QC3 is forbidden
QB9REL	BOOLEAN	Switching of QB9 is allowed
QB9ITL	BOOLEAN	Switching of QB9 is forbidden
QC9REL	BOOLEAN	Switching of QC9 is allowed
QC9ITL	BOOLEAN	Switching of QC9 is forbidden
QB1OPTR	BOOLEAN	QB1 is in open position
QB1CLTR	BOOLEAN	QB1 is in closed position
VPQB1TR	BOOLEAN	Switch status of QB1 is valid (open or closed)

Table 214: BH_LINE_B Output signals

Name	Type	Description
QA1CLREL	BOOLEAN	Closing of QA1 is allowed
QA1CLITL	BOOLEAN	Closing of QA1 is forbidden
QB6REL	BOOLEAN	Switching of QB6 is allowed
QB6ITL	BOOLEAN	Switching of QB6 is forbidden
QB2REL	BOOLEAN	Switching of QB2 is allowed
QB2ITL	BOOLEAN	Switching of QB2 is forbidden
QC1REL	BOOLEAN	Switching of QC1 is allowed
QC1ITL	BOOLEAN	Switching of QC1 is forbidden
QC2REL	BOOLEAN	Switching of QC2 is allowed
QC2ITL	BOOLEAN	Switching of QC2 is forbidden
QC3REL	BOOLEAN	Switching of QC3 is allowed
QC3ITL	BOOLEAN	Switching of QC3 is forbidden
QB9REL	BOOLEAN	Switching of QB9 is allowed
QB9ITL	BOOLEAN	Switching of QB9 is forbidden
QC9REL	BOOLEAN	Switching of QC9 is allowed
QC9ITL	BOOLEAN	Switching of QC9 is forbidden
QB2OPTR	BOOLEAN	QB2 is in open position
QB2CLTR	BOOLEAN	QB2 is in closed position
VPQB2TR	BOOLEAN	Switch status of QB2 is valid (open or closed)

10.4.7.6 Settings

The function does not have any settings available in Local HMI or Protection and Control IED Manager (PCM600).

10.4.8 Interlocking for double CB bay DB

10.4.8.1 Identification

Function description	IEC 61850 identification	IEC 60617 identification	ANSI/IEEE C37.2 device number
Interlocking for double CB bay	DB_BUS_A	-	3
Interlocking for double CB bay	DB_BUS_B	-	3
Interlocking for double CB bay	DB_LINE	-	3

10.4.8.2 Functionality

The interlocking for a double busbar double circuit breaker bay including DB_BUS_A, DB_BUS_B and DB_LINE functions are used for a line connected to a double busbar arrangement according to figure 143.

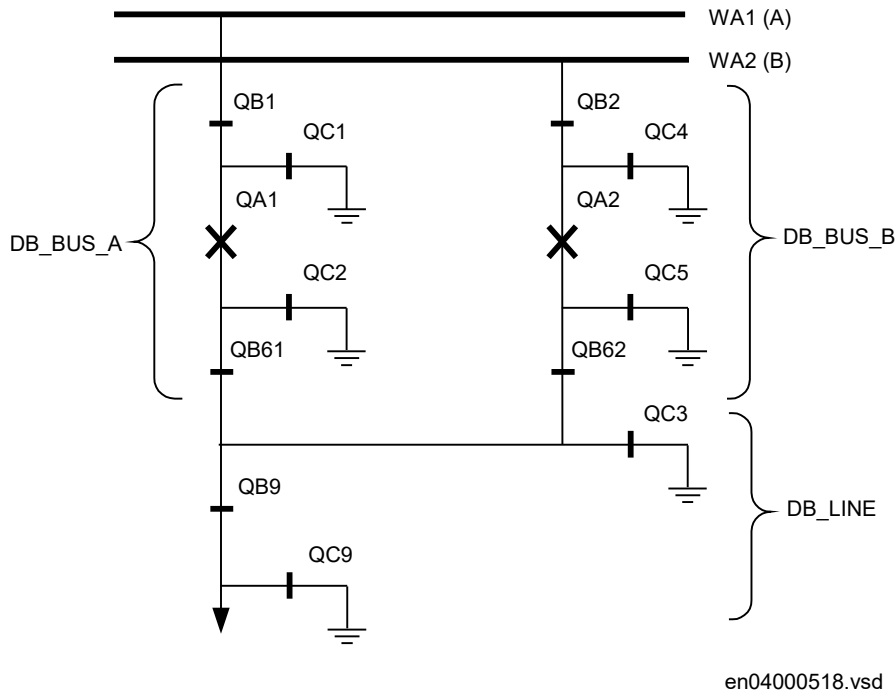

Figure 143: Switchyard layout double circuit breaker

Three types of interlocking modules per double circuit breaker bay are defined. DB_BUS_A handles the circuit breaker QA1 that is connected to busbar WA1 and the disconnectors and earthing switches of this section. DB_BUS_B handles the circuit breaker QA2 that is connected to busbar WA2 and the disconnectors and earthing switches of this section.

10.4.8.3 Function block

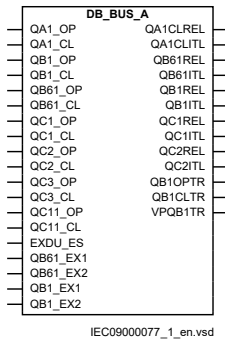

Figure 144: DB_BUS_A function block

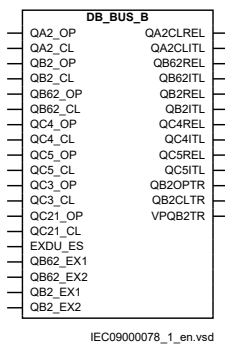

Figure 145: DB_BUS_B function block

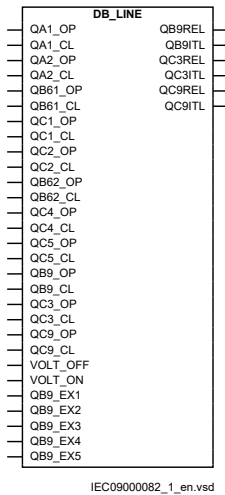
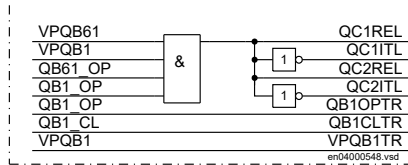
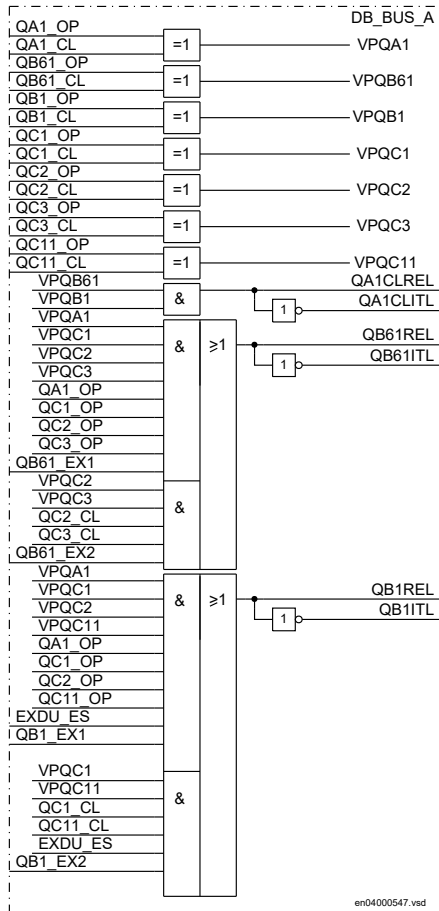
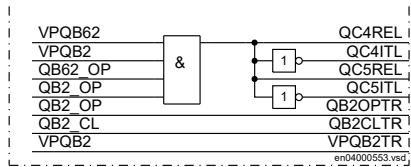
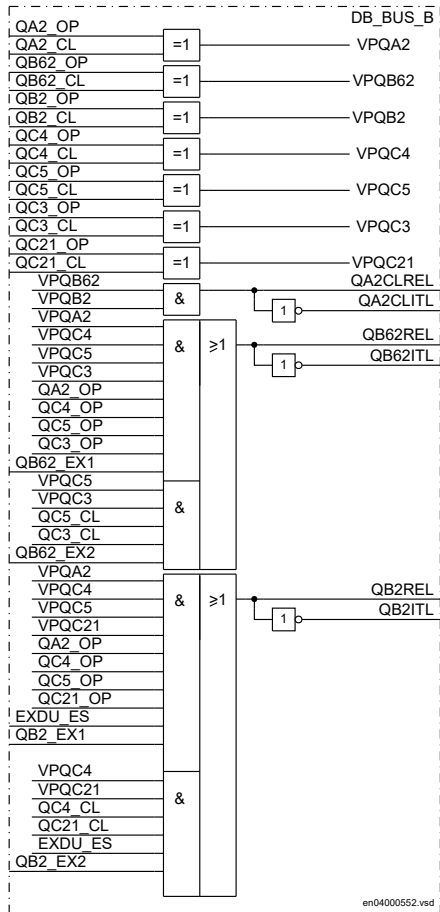
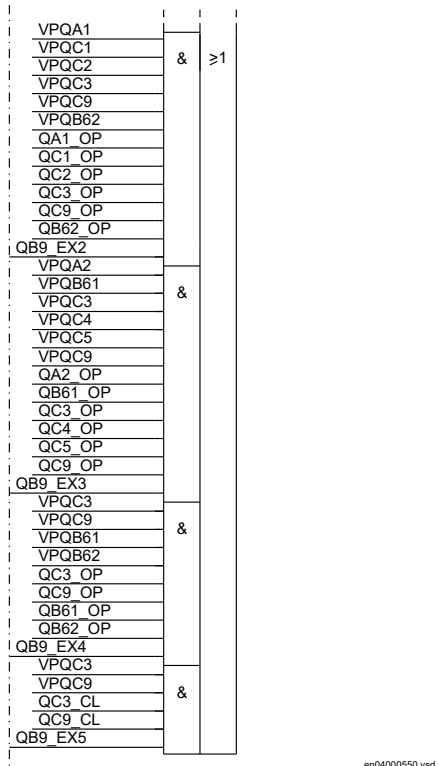
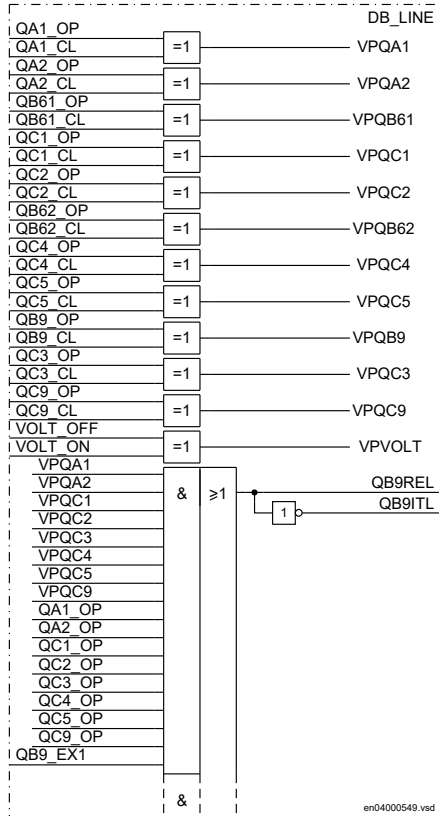

Figure 146: DB_LINE function block

10.4.8.4 Logic diagrams







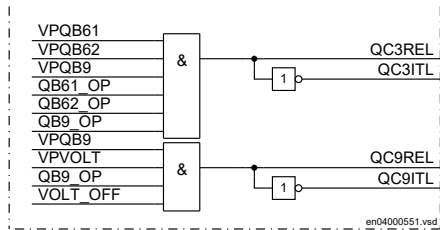

10.4.8.5 Signals

Table 215: DB_BUS_A Input signals

Name	Type	Default	Description
QA1_OP	BOOLEAN	0	QA1 is in open position
QA1_CL	BOOLEAN	0	QA1 is in closed position
QB1_OP	BOOLEAN	0	QB1 is in open position
QB1_CL	BOOLEAN	0	QB1 is in closed position
QB61_OP	BOOLEAN	0	QB61 is in open position
QB61_CL	BOOLEAN	0	QB61 is in closed position
QC1_OP	BOOLEAN	0	QC1 is in open position
QC1_CL	BOOLEAN	0	QC1 is in closed position
QC2_OP	BOOLEAN	0	QC2 is in open position
QC2_CL	BOOLEAN	0	QC2 is in closed position
QC3_OP	BOOLEAN	0	QC3 is in open position
QC3_CL	BOOLEAN	0	QC3 is in closed position
QC11_OP	BOOLEAN	0	Earthing switch QC11 on busbar WA1 is in open position
QC11_CL	BOOLEAN	0	Earthing switch QC11 on busbar WA1 is in closed position
EXDU_ES	BOOLEAN	0	No transmission error from bay containing earthing switch QC11
QB61_EX1	BOOLEAN	0	External condition for apparatus QB61
QB61_EX2	BOOLEAN	0	External condition for apparatus QB61
QB1_EX1	BOOLEAN	0	External condition for apparatus QB1
QB1_EX2	BOOLEAN	0	External condition for apparatus QB1

Table 216: DB_BUS_B Input signals

Name	Type	Default	Description
QA2_OP	BOOLEAN	0	QA2 is in open position
QA2_CL	BOOLEAN	0	QA2 is in closed position
QB2_OP	BOOLEAN	0	QB2 is in open position
QB2_CL	BOOLEAN	0	QB2 is in closed position
QB62_OP	BOOLEAN	0	QB62 is in open position
QB62_CL	BOOLEAN	0	QB62 is in closed position
QC4_OP	BOOLEAN	0	QC4 is in open position
QC4_CL	BOOLEAN	0	QC4 is in closed position

Table continues on next page

Name	Type	Default	Description
QC5_OP	BOOLEAN	0	QC5 is in open position
QC5_CL	BOOLEAN	0	QC5 is in closed position
QC3_OP	BOOLEAN	0	QC3 is in open position
QC3_CL	BOOLEAN	0	QC3 is in closed position
QC21_OP	BOOLEAN	0	Earthing switch QC21 on busbar WA2 is in open position
QC21_CL	BOOLEAN	0	Earthing switch QC21 on busbar WA2 is in closed position
EXDU_ES	BOOLEAN	0	No transmission error from bay containing earthing switch QC21
QB62_EX1	BOOLEAN	0	External condition for apparatus QB62
QB62_EX2	BOOLEAN	0	External condition for apparatus QB62
QB2_EX1	BOOLEAN	0	External condition for apparatus QB2
QB2_EX2	BOOLEAN	0	External condition for apparatus QB2

Table 217: DB_LINE Input signals

Name	Type	Default	Description
QA1_OP	BOOLEAN	0	QA1 is in open position
QA1_CL	BOOLEAN	0	QA1 is in closed position
QA2_OP	BOOLEAN	0	QA2 is in open position
QA2_CL	BOOLEAN	0	QA2 is in closed position
QB61_OP	BOOLEAN	0	QB61 is in open position
QB61_CL	BOOLEAN	0	QB61 is in closed position
QC1_OP	BOOLEAN	0	QC1 is in open position
QC1_CL	BOOLEAN	0	QC1 is in closed position
QC2_OP	BOOLEAN	0	QC2 is in open position
QC2_CL	BOOLEAN	0	QC2 is in closed position
QB62_OP	BOOLEAN	0	QB62 is in open position
QB62_CL	BOOLEAN	0	QB62 is in closed position
QC4_OP	BOOLEAN	0	QC4 is in open position
QC4_CL	BOOLEAN	0	QC4 is in closed position
QC5_OP	BOOLEAN	0	QC5 is in open position
QC5_CL	BOOLEAN	0	QC5 is in closed position
QB9_OP	BOOLEAN	0	QB9 is in open position
QB9_CL	BOOLEAN	0	QB9 is in closed position
QC3_OP	BOOLEAN	0	QC3 is in open position
QC3_CL	BOOLEAN	0	QC3 is in closed position
QC9_OP	BOOLEAN	0	QC9 is in open position
QC9_CL	BOOLEAN	0	QC9 is in closed position
VOLT_OFF	BOOLEAN	0	There is no voltage on the line and not VT (fuse) failure
VOLT_ON	BOOLEAN	0	There is voltage on the line or there is a VT (fuse) failure
QB9_EX1	BOOLEAN	0	External condition for apparatus QB9
QB9_EX2	BOOLEAN	0	External condition for apparatus QB9

Table continues on next page

Name	Type	Default	Description
QB9_EX3	BOOLEAN	0	External condition for apparatus QB9
QB9_EX4	BOOLEAN	0	External condition for apparatus QB9
QB9_EX5	BOOLEAN	0	External condition for apparatus QB9

Table 218: DB_BUS_A Output signals

Name	Type	Description
QA1CLREL	BOOLEAN	Closing of QA1 is allowed
QA1CLITL	BOOLEAN	Closing of QA1 is forbidden
QB61REL	BOOLEAN	Switching of QB61 is allowed
QB61ITL	BOOLEAN	Switching of QB61 is forbidden
QB1REL	BOOLEAN	Switching of QB1 is allowed
QB1ITL	BOOLEAN	Switching of QB1 is forbidden
QC1REL	BOOLEAN	Switching of QC1 is allowed
QC1ITL	BOOLEAN	Switching of QC1 is forbidden
QC2REL	BOOLEAN	Switching of QC2 is allowed
QC2ITL	BOOLEAN	Switching of QC2 is forbidden
QB1OPTR	BOOLEAN	QB1 is in open position
QB1CLTR	BOOLEAN	QB1 is in closed position
VPQB1TR	BOOLEAN	Switch status of QB1 is valid (open or closed)

Table 219: DB_BUS_B Output signals

Name	Type	Description
QA2CLREL	BOOLEAN	Closing of QA2 is allowed
QA2CLITL	BOOLEAN	Closing of QA2 is forbidden
QB62REL	BOOLEAN	Switching of QB62 is allowed
QB62ITL	BOOLEAN	Switching of QB62 is forbidden
QB2REL	BOOLEAN	Switching of QB2 is allowed
QB2ITL	BOOLEAN	Switching of QB2 is forbidden
QC4REL	BOOLEAN	Switching of QC4 is allowed
QC4ITL	BOOLEAN	Switching of QC4 is forbidden
QC5REL	BOOLEAN	Switching of QC5 is allowed
QC5ITL	BOOLEAN	Switching of QC5 is forbidden
QB2OPTR	BOOLEAN	QB2 is in open position
QB2CLTR	BOOLEAN	QB2 is in closed position
VPQB2TR	BOOLEAN	Switch status of QB2 is valid (open or closed)

Table 220: DB_LINE Output signals

Name	Type	Description
QB9REL	BOOLEAN	Switching of QB9 is allowed
QB9ITL	BOOLEAN	Switching of QB9 is forbidden
QC3REL	BOOLEAN	Switching of QC3 is allowed
QC3ITL	BOOLEAN	Switching of QC3 is forbidden
QC9REL	BOOLEAN	Switching of QC9 is allowed
QC9ITL	BOOLEAN	Switching of QC9 is forbidden

10.4.8.6 Settings

The function does not have any settings available in Local HMI or Protection and Control IED Manager (PCM600).

10.4.9 Interlocking for line bay ABC_LINE

10.4.9.1 Identification

Function description	IEC 61850 identification	IEC 60617 identification	ANSI/IEEE C37.2 device number
Interlocking for line bay	ABC_LINE	-	3

10.4.9.2 Functionality

The interlocking for line bay (ABC_LINE) function is used for a line connected to a double busbar arrangement with a transfer busbar according to figure 147. The function can also be used for a double busbar arrangement without transfer busbar or a single busbar arrangement with/without transfer busbar.

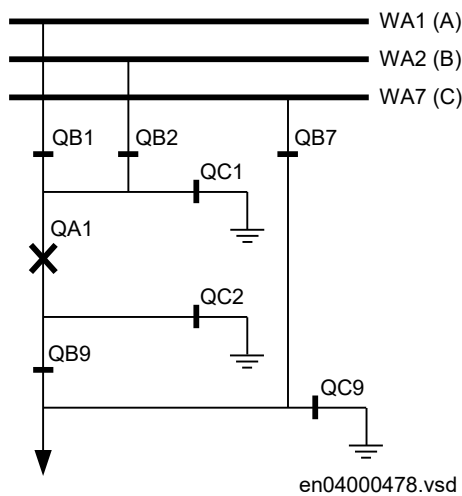

Figure 147: Switchyard layout ABC_LINE



The interlocking functionality in 650 series can not handle the transfer bus (WA7)C.

10.4.9.3 Function block

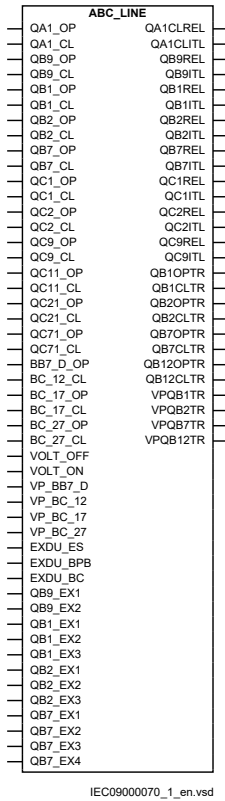
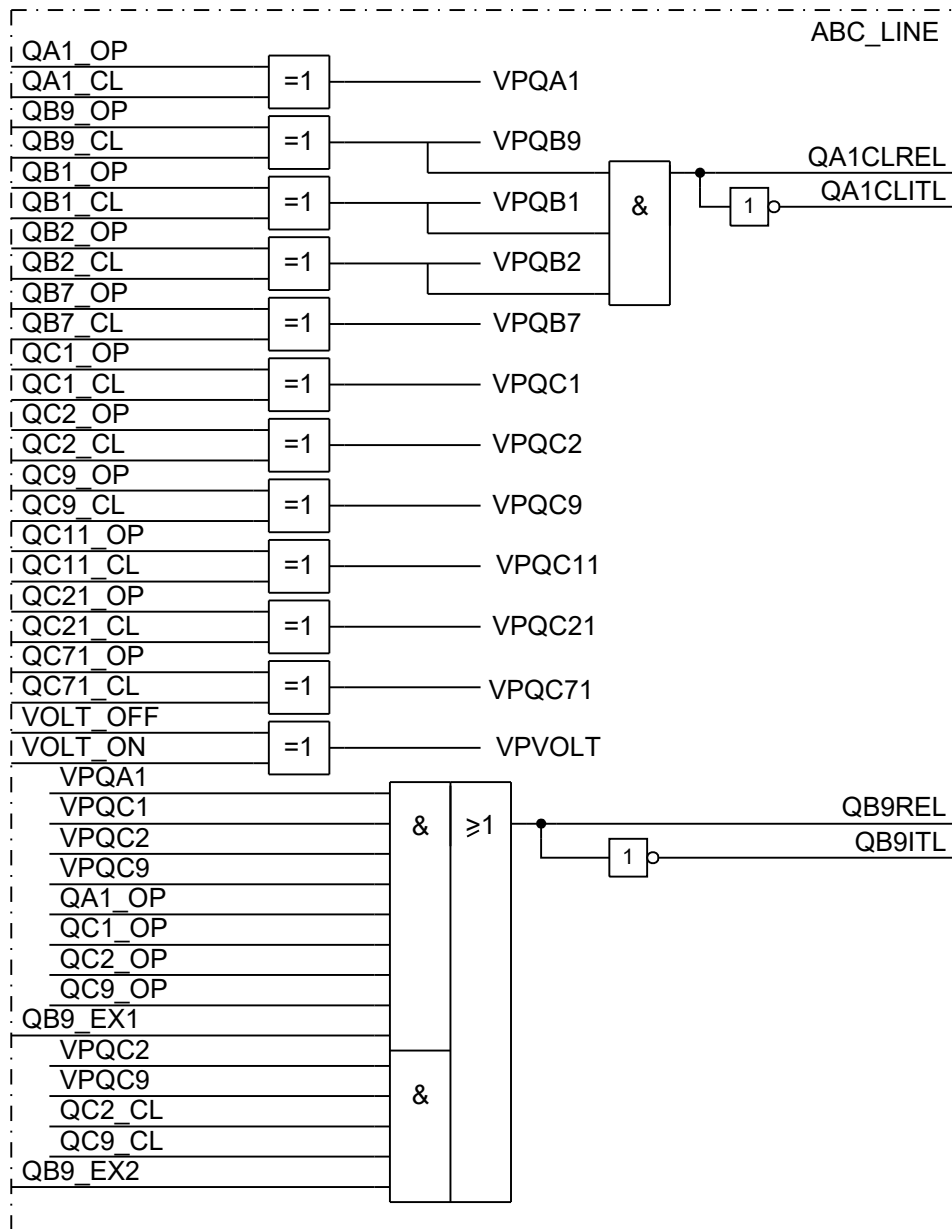
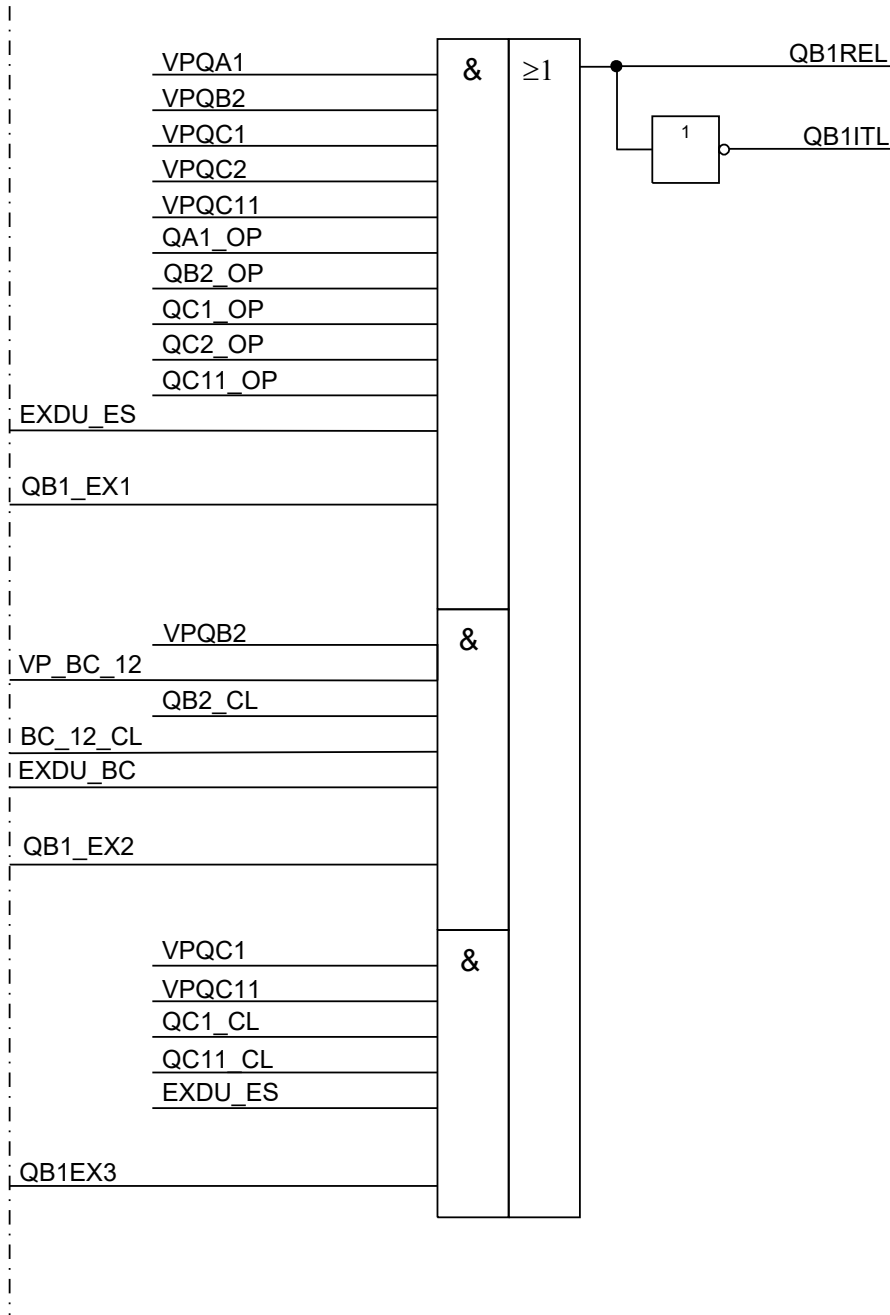

Figure 148: ABC_LINE function block

10.4.9.4 Logic diagram





en04000528.vsd

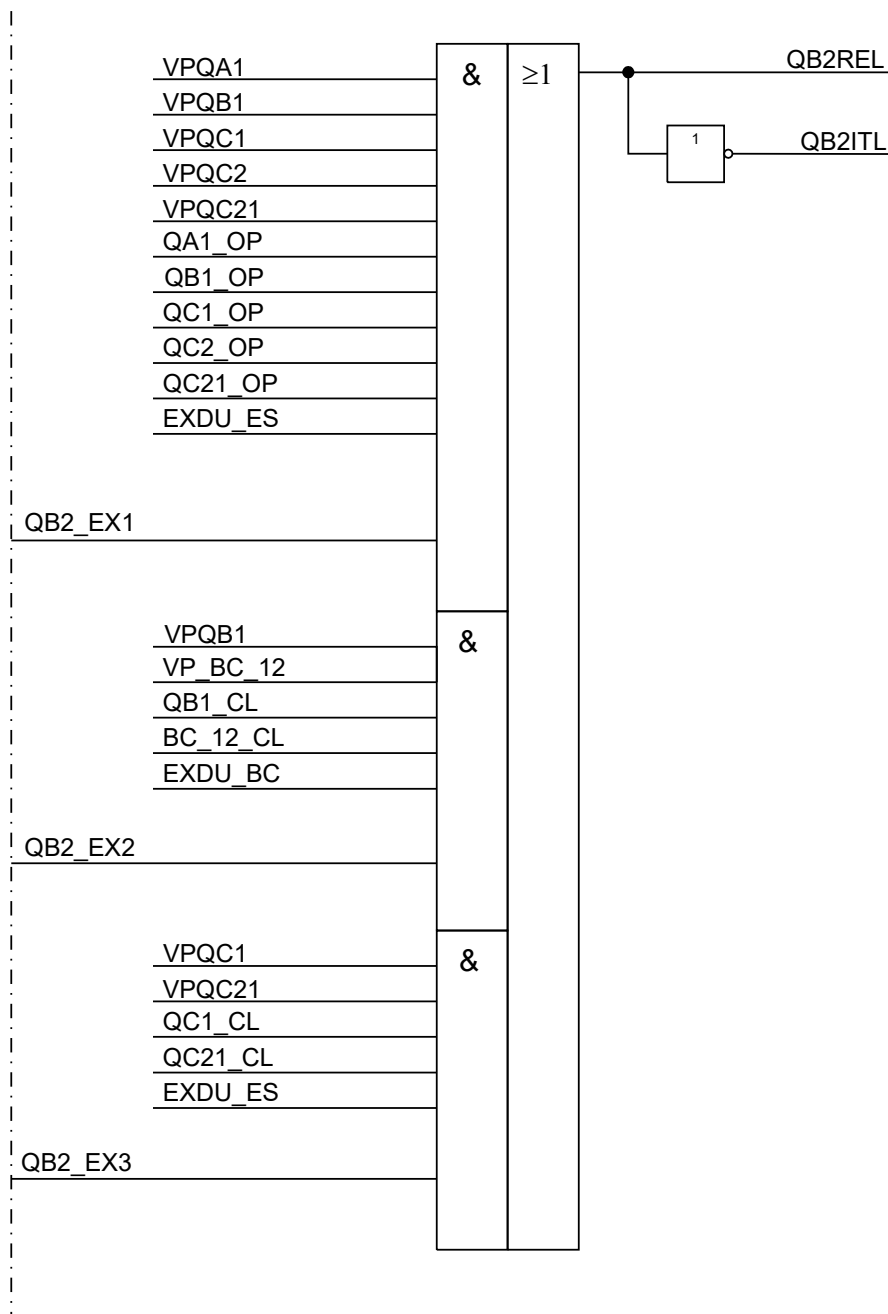

en04000529.vsd

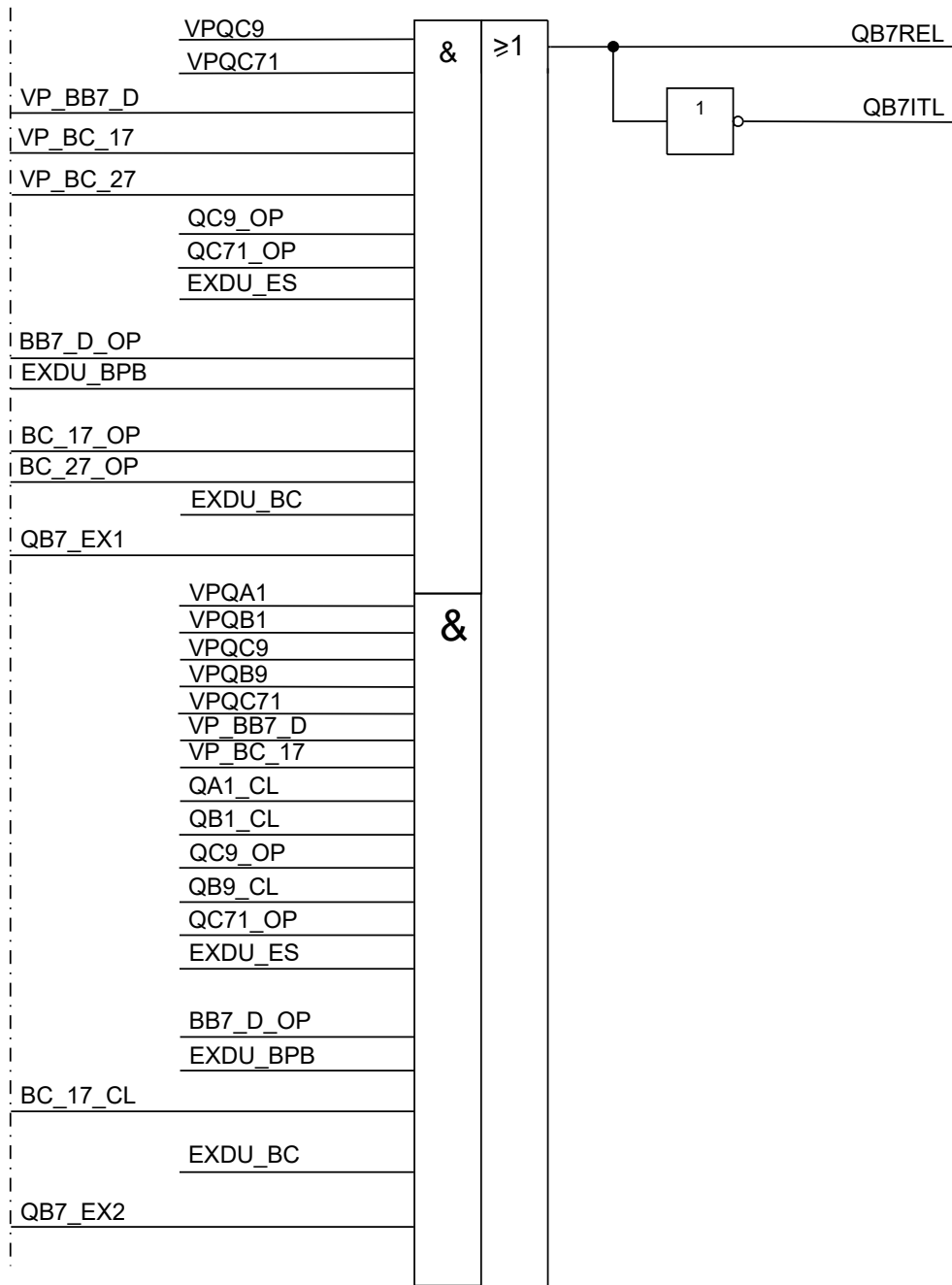

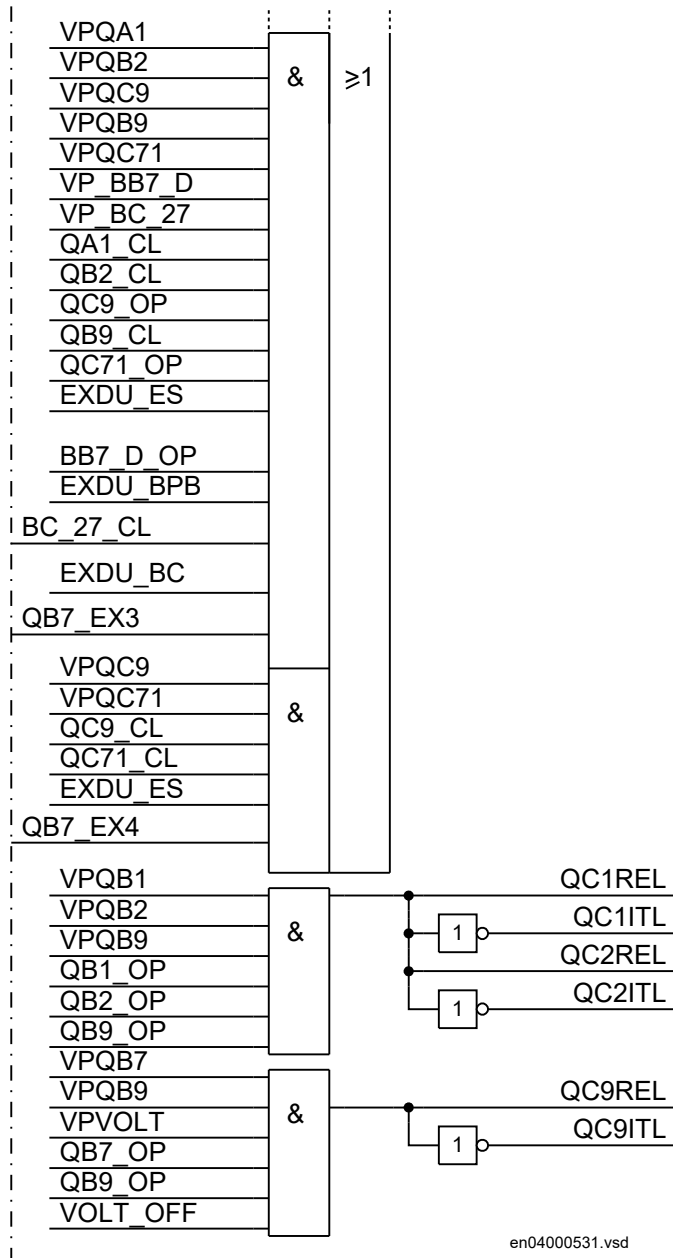

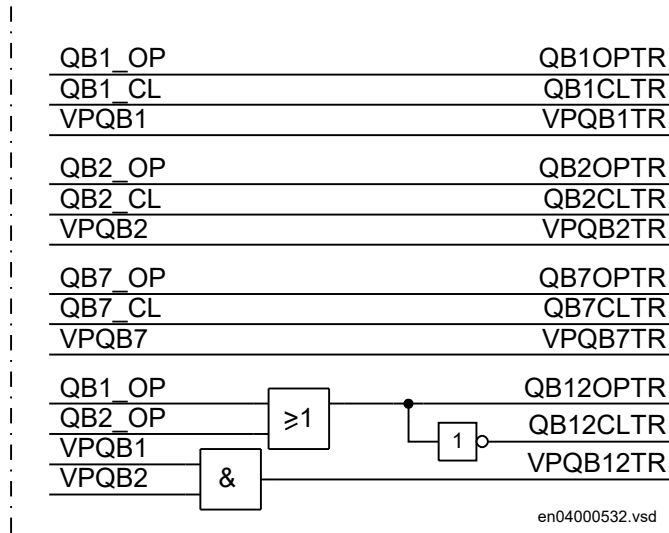

10.4.9.5 Signals

Table 221: ABC_LINE Input signals

Name	Type	Default	Description
QA1_OP	BOOLEAN	0	QA1 is in open position
QA1_CL	BOOLEAN	0	QA1 is in closed position
QB9_OP	BOOLEAN	0	QB9 is in open position
QB9_CL	BOOLEAN	0	QB9 is in closed position
QB1_OP	BOOLEAN	0	QB1 is in open position
QB1_CL	BOOLEAN	0	QB1 is in closed position
QB2_OP	BOOLEAN	0	QB2 is in open position
QB2_CL	BOOLEAN	0	QB2 is in closed position
QB7_OP	BOOLEAN	0	QB7 is in open position
QB7_CL	BOOLEAN	0	QB7 is in closed position
QC1_OP	BOOLEAN	0	QC1 is in open position
QC1_CL	BOOLEAN	0	QC1 is in closed position
QC2_OP	BOOLEAN	0	QC2 is in open position
QC2_CL	BOOLEAN	0	QC2 is in closed position
QC9_OP	BOOLEAN	0	QC9 is in open position
QC9_CL	BOOLEAN	0	QC9 is in closed position
QC11_OP	BOOLEAN	0	Earthing switch QC11 on busbar WA1 is in open position
QC11_CL	BOOLEAN	0	Earthing switch QC11 on busbar WA1 is in closed position
QC21_OP	BOOLEAN	0	Earthing switch QC21 on busbar WA2 is in open position
QC21_CL	BOOLEAN	0	Earthing switch QC21 on busbar WA2 is in closed position
QC71_OP	BOOLEAN	0	Earthing switch QC71 on busbar WA7 is in open position
QC71_CL	BOOLEAN	0	Earthing switch QC71 on busbar WA7 is in closed position
BB7_D_OP	BOOLEAN	0	Disconnectors on busbar WA7 except in the own bay are open
BC_12_CL	BOOLEAN	0	A bus coupler connection exists between busbar WA1 and WA2

Table continues on next page

Name	Type	Default	Description
BC_17_OP	BOOLEAN	0	No bus coupler connection exists between busbar WA1 and WA7
BC_17_CL	BOOLEAN	0	A bus coupler connection exists between busbar WA1 and WA7
BC_27_OP	BOOLEAN	0	No bus coupler connection exists between busbar WA2 and WA7
BC_27_CL	BOOLEAN	0	A bus coupler connection exists between busbar WA2 and WA7
VOLT_OFF	BOOLEAN	0	There is no voltage on the line and not VT (fuse) failure
VOLT_ON	BOOLEAN	0	There is voltage on the line or there is a VT (fuse) failure
VP_BB7_D	BOOLEAN	0	Switch status of the disconnectors on busbar WA7 are valid
VP_BC_12	BOOLEAN	0	Status of the bus coupler apparatuses between WA1 and WA2 are valid
VP_BC_17	BOOLEAN	0	Status of the bus coupler apparatuses between WA1 and WA7 are valid
VP_BC_27	BOOLEAN	0	Status of the bus coupler apparatus between WA2 and WA7 are valid
EXDU_ES	BOOLEAN	0	No transmission error from any bay containing earthing switches
EXDU_BPB	BOOLEAN	0	No transmission error from any bay with disconnectors on WA7
EXDU_BC	BOOLEAN	0	No transmission error from any bus coupler bay
QB9_EX1	BOOLEAN	0	External condition for apparatus QB9
QB9_EX2	BOOLEAN	0	External condition for apparatus QB9
QB1_EX1	BOOLEAN	0	External condition for apparatus QB1
QB1_EX2	BOOLEAN	0	External condition for apparatus QB1
QB1_EX3	BOOLEAN	0	External condition for apparatus QB1
QB2_EX1	BOOLEAN	0	External condition for apparatus QB2
QB2_EX2	BOOLEAN	0	External condition for apparatus QB2
QB2_EX3	BOOLEAN	0	External condition for apparatus QB2
QB7_EX1	BOOLEAN	0	External condition for apparatus QB7
QB7_EX2	BOOLEAN	0	External condition for apparatus QB7
QB7_EX3	BOOLEAN	0	External condition for apparatus QB7
QB7_EX4	BOOLEAN	0	External condition for apparatus QB7

Table 222: ABC_LINE Output signals

Name	Type	Description
QA1CLREL	BOOLEAN	Closing of QA1 is allowed
QA1CLITL	BOOLEAN	Closing of QA1 is forbidden
QB9REL	BOOLEAN	Switching of QB9 is allowed
QB9ITL	BOOLEAN	Switching of QB9 is forbidden
QB1REL	BOOLEAN	Switching of QB1 is allowed
QB1ITL	BOOLEAN	Switching of QB1 is forbidden
QB2REL	BOOLEAN	Switching of QB2 is allowed

Table continues on next page

Name	Type	Description
QB2ITL	BOOLEAN	Switching of QB2 is forbidden
QB7REL	BOOLEAN	Switching of QB7 is allowed
QB7ITL	BOOLEAN	Switching of QB7 is forbidden
QC1REL	BOOLEAN	Switching of QC1 is allowed
QC1ITL	BOOLEAN	Switching of QC1 is forbidden
QC2REL	BOOLEAN	Switching of QC2 is allowed
QC2ITL	BOOLEAN	Switching of QC2 is forbidden
QC9REL	BOOLEAN	Switching of QC9 is allowed
QC9ITL	BOOLEAN	Switching of QC9 is forbidden
QB1OPTR	BOOLEAN	QB1 is in open position
QB1CLTR	BOOLEAN	QB1 is in closed position
QB2OPTR	BOOLEAN	QB2 is in open position
QB2CLTR	BOOLEAN	QB2 is in closed position
QB7OPTR	BOOLEAN	QB7 is in open position
QB7CLTR	BOOLEAN	QB7 is in closed position
QB12OPTR	BOOLEAN	QB1 or QB2 or both are in open position
QB12CLTR	BOOLEAN	QB1 and QB2 are not in open position
VPQB1TR	BOOLEAN	Switch status of QB1 is valid (open or closed)
VPQB2TR	BOOLEAN	Switch status of QB2 is valid (open or closed)
VPQB7TR	BOOLEAN	Switch status of QB7 is valid (open or closed)
VPQB12TR	BOOLEAN	Switch status of QB1 and QB2 are valid (open or closed)

10.4.9.6 Settings

The function does not have any settings available in Local HMI or Protection and Control IED Manager (PCM600).

10.4.10 Interlocking for transformer bay AB_TRAFO

10.4.10.1 Identification

Function description	IEC 61850 identification	IEC 60617 identification	ANSI/IEEE C37.2 device number
Interlocking for transformer bay	AB_TRAFO	-	3

10.4.10.2 Functionality

The interlocking for transformer bay (AB_TRAFO) function is used for a transformer bay connected to a double busbar arrangement according to figure 149. The function is used when there is no disconnecter between circuit breaker and transformer. Otherwise, the interlocking for line bay (ABC_LINE) function can be used. This function can also be used in single busbar arrangements.

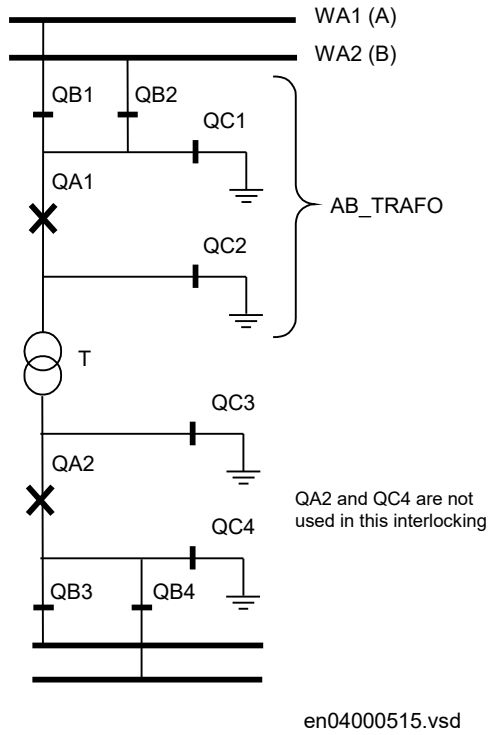

Figure 149: Switchyard layout AB_TRAFO

10.4.10.3 Function block

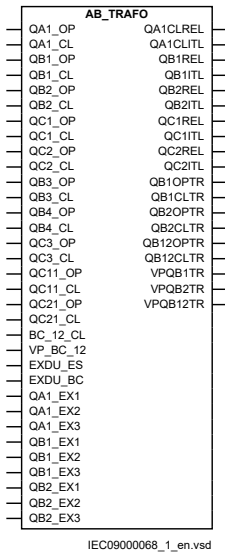
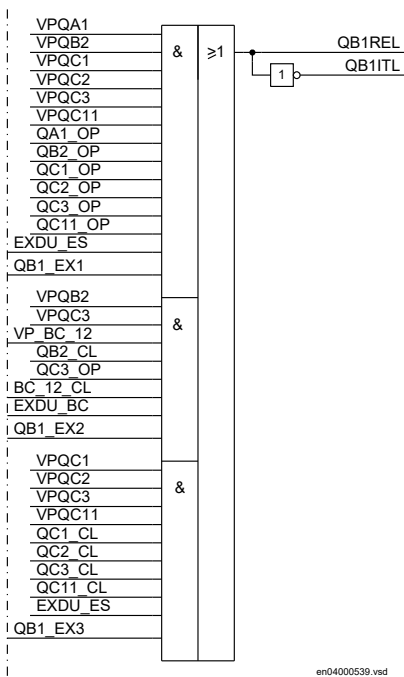
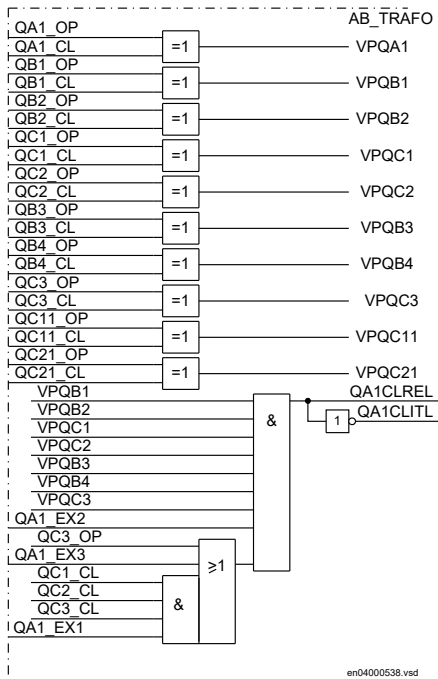
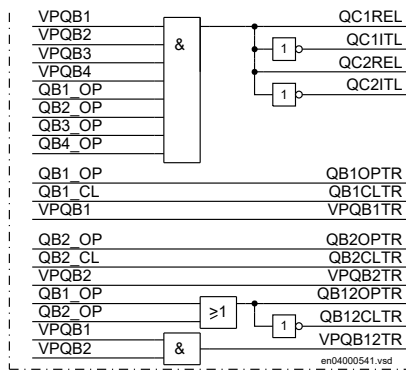
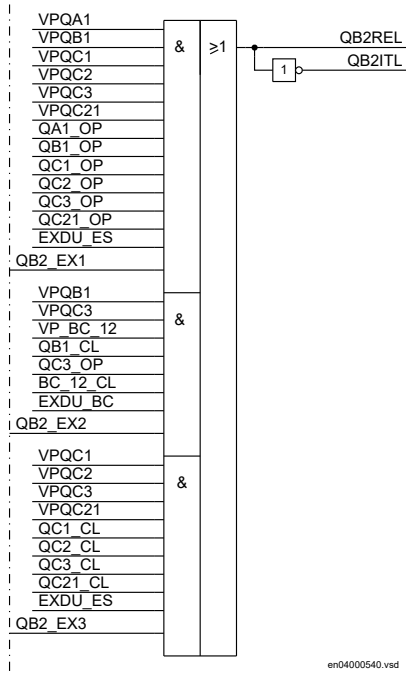

Figure 150: AB_TRAFO function block

10.4.10.4 Logic diagram





10.4.10.5 Signals

Table 223: AB_TRAFO Input signals

Name	Type	Default	Description
QA1_OP	BOOLEAN	0	QA1 is in open position
QA1_CL	BOOLEAN	0	QA1 is in closed position
QB1_OP	BOOLEAN	0	QB1 is in open position
QB1_CL	BOOLEAN	0	QB1 is in closed position
QB2_OP	BOOLEAN	0	QB2 is in open position
QB2_CL	BOOLEAN	0	QB2 is in closed position
QC1_OP	BOOLEAN	0	QC1 is in open position
QC1_CL	BOOLEAN	0	QC1 is in closed position
QC2_OP	BOOLEAN	0	QC2 is in open position
QC2_CL	BOOLEAN	0	QC2 is in closed position
QB3_OP	BOOLEAN	0	QB3 is in open position

Table continues on next page

Name	Type	Default	Description
QB3_CL	BOOLEAN	0	QB3 is in closed position
QB4_OP	BOOLEAN	0	QB4 is in open position
QB4_CL	BOOLEAN	0	QB4 is in closed position
QC3_OP	BOOLEAN	0	QC3 is in open position
QC3_CL	BOOLEAN	0	QC3 is in closed position
QC11_OP	BOOLEAN	0	QC11 on busbar WA1 is in open position
QC11_CL	BOOLEAN	0	QC11 on busbar WA1 is in closed position
QC21_OP	BOOLEAN	0	QC21 on busbar WA2 is in open position
QC21_CL	BOOLEAN	0	QC21 on busbar WA2 is in closed position
BC_12_CL	BOOLEAN	0	A bus coupler connection exists between busbar WA1 and WA2
VP_BC_12	BOOLEAN	0	Status of the bus coupler apparatuses between WA1 and WA2 are valid
EXDU_ES	BOOLEAN	0	No transmission error from any bay containing earthing switches
EXDU_BC	BOOLEAN	0	No transmission error from any bus coupler bay
QA1_EX1	BOOLEAN	0	External condition for apparatus QA1
QA1_EX2	BOOLEAN	0	External condition for apparatus QA1
QA1_EX3	BOOLEAN	0	External condition for apparatus QA1
QB1_EX1	BOOLEAN	0	External condition for apparatus QB1
QB1_EX2	BOOLEAN	0	External condition for apparatus QB1
QB1_EX3	BOOLEAN	0	External condition for apparatus QB1
QB2_EX1	BOOLEAN	0	External condition for apparatus QB2
QB2_EX2	BOOLEAN	0	External condition for apparatus QB2
QB2_EX3	BOOLEAN	0	External condition for apparatus QB2

Table 224: AB_TRAFO Output signals

Name	Type	Description
QA1CLREL	BOOLEAN	Closing of QA1 is allowed
QA1CLITL	BOOLEAN	Closing of QA1 is forbidden
QB1REL	BOOLEAN	Switching of QB1 is allowed
QB1ITL	BOOLEAN	Switching of QB1 is forbidden
QB2REL	BOOLEAN	Switching of QB2 is allowed
QB2ITL	BOOLEAN	Switching of QB2 is forbidden
QC1REL	BOOLEAN	Switching of QC1 is allowed
QC1ITL	BOOLEAN	Switching of QC1 is forbidden
QC2REL	BOOLEAN	Switching of QC2 is allowed
QC2ITL	BOOLEAN	Switching of QC2 is forbidden
QB1OPTR	BOOLEAN	QB1 is in open position
QB1CLTR	BOOLEAN	QB1 is in closed position
QB2OPTR	BOOLEAN	QB2 is in open position
QB2CLTR	BOOLEAN	QB2 is in closed position

Table continues on next page

Name	Type	Description
QB12OPTR	BOOLEAN	QB1 or QB2 or both are in open position
QB12CLTR	BOOLEAN	QB1 and QB2 are not in open position
VPQB1TR	BOOLEAN	Switch status of QB1 is valid (open or closed)
VPQB2TR	BOOLEAN	Switch status of QB2 is valid (open or closed)
VPQB12TR	BOOLEAN	Switch status of QB1 and QB2 are valid (open or closed)

10.4.10.6 Settings

The function does not have any settings available in Local HMI or Protection and Control IED Manager (PCM600).

10.4.11 Position evaluation POS_EVAL

10.4.11.1 Identification

Function description	IEC 61850 identification	IEC 60617 identification	ANSI/IEEE C37.2 device number
Position evaluation	POS_EVAL	-	-

10.4.11.2 Functionality

Position evaluation (POS_EVAL) function converts the input position data signal POSITION, consisting of value, time and signal status, to binary signals OPENPOS or CLOSEPOS.

The output signals are used by other functions in the interlocking scheme.

10.4.11.3 Function block

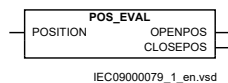
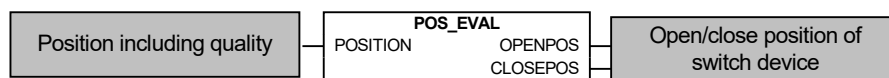

Figure 151: POS_EVAL function block

10.4.11.4 Logic diagram



IEC08000469-1-en.vsd

Only the value, open/close, and status is used in this function. Time information is not used.

Input position (Value)	Signal quality	Output OPENPOS	Output CLOSEPOS
0 (Breaker intermediate)	Good	0	0
1 (Breaker open)	Good	1	0
2 (Breaker closed)	Good	0	1

Table continues on next page

Input position (Value)	Signal quality	Output OPENPOS	Output CLOSEPOS
3 (Breaker faulty)	Good	0	0
Any	Invalid	0	0
Any	Oscillatory	0	0

10.4.11.5 Signals

Table 225: POS_EVAL Input signals

Name	Type	Default	Description
POSITION	INTEGER	0	Position status including quality

Table 226: POS_EVAL Output signals

Name	Type	Description
OPENPOS	BOOLEAN	Open position
CLOSEPOS	BOOLEAN	Close position

10.4.11.6 Settings

The function does not have any settings available in Local HMI or Protection and Control IED Manager (PCM600).

10.4.12 Operation principle

The interlocking function consists of software modules located in each control IED. The function is distributed and not dependent on any central function. Communication between modules in different bays is performed via the station bus.

The reservation function is used to ensure that HV apparatuses that might affect the interlock are blocked during the time gap, which arises between position updates. This can be done by means of the communication system, reserving all HV apparatuses that might influence the interlocking condition of the intended operation. The reservation is maintained until the operation is performed.

After the selection and reservation of an apparatus, the function has complete data on the status of all apparatuses in the switchyard that are affected by the selection. Other operators cannot interfere with the reserved apparatus or the status of switching devices that may affect it.

The open or closed positions of the HV apparatuses are inputs to software modules distributed in the control IEDs. Each module contains the interlocking logic for a bay. The interlocking logic in a module is different, depending on the bay function and the switchyard arrangements, that is, double-breaker or 1 1/2 breaker bays have different modules. Specific interlocking conditions and connections between standard interlocking modules are performed with an engineering tool. Bay-level interlocking signals can include the following kind of information:

- Positions of HV apparatuses (sometimes per phase)
- Valid positions (if evaluated in the control module)
- External release (to add special conditions for release)
- Line voltage (to block operation of line earthing switch)
- Output signals to release the HV apparatus

The interlocking module is connected to the surrounding functions within a bay as shown in figure 152.

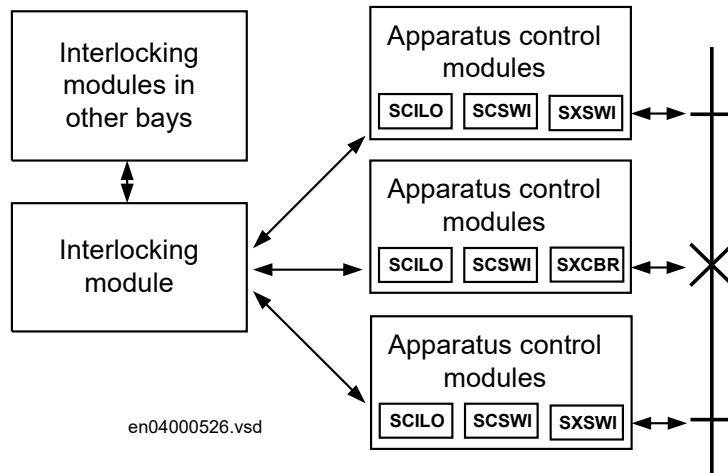

Figure 152: Interlocking module on bay level

Bays communicate via the station bus and can convey information regarding the following:

- Unearthed busbars
- Busbars connected together
- Other bays connected to a busbar
- Received data from other bays is valid

Figure 153 illustrates the data exchange principle.

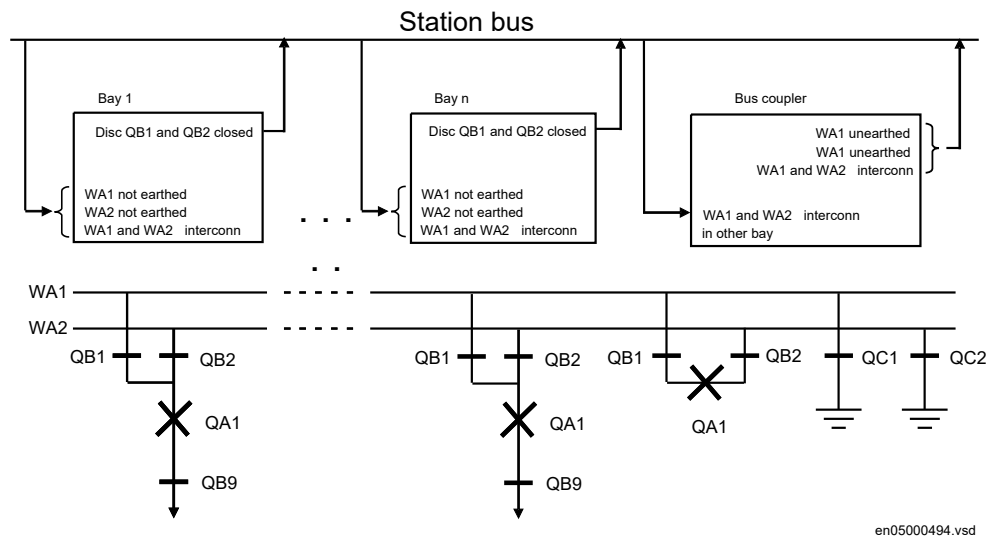

Figure 153: Data exchange between interlocking modules

When invalid data such as intermediate position, loss of a control IED, or input board error are used as conditions for the interlocking condition in a bay, a release for execution of the function will not be given.

On the local HMI an override function exists, which can be used to bypass the interlocking function in cases where not all the data required for the condition is valid.

For all interlocking modules these general rules apply:

- The interlocking conditions for opening or closing of disconnectors and earthing switches are always identical.
- Earthing switches on the line feeder end, for example, rapid earthing switches, are normally interlocked only with reference to the conditions in the bay where they are located, not with reference to switches on the other side of the line. So a line voltage indication may be included into line interlocking modules. If there is no line voltage supervision within the bay, then the appropriate inputs must be set to *no voltage*, and the operator must consider this when operating.
- Earthing switches can only be operated on isolated sections for example, without load/voltage. Circuit breaker contacts cannot be used to isolate a section, that is, the status of the circuit breaker is irrelevant as far as the earthing switch operation is concerned.
- Disconnectors cannot break power current or connect different voltage systems. Disconnectors in series with a circuit breaker can only be operated if the circuit breaker is open, or if the disconnectors operate in parallel with other closed connections. Other disconnectors can be operated if one side is completely isolated, or if the disconnectors operate in parallel to other closed connections, or if they are earthed on both sides.
- Circuit breaker closing is only interlocked against running disconnectors in its bay or additionally in a transformer bay against the disconnectors and earthing switch on the other side of the transformer, if there is no disconnector between CB and transformer.
- Circuit breaker opening is only interlocked in a bus-coupler bay, if a bus bar transfer is in progress.

To make the implementation of the interlocking function easier, a number of standardized and tested software interlocking modules containing logic for the interlocking conditions are available:

- Line for double and transfer busbars, ABC_LINE
- Bus for double and transfer busbars, ABC_BC
- Transformer bay for double busbars, AB_TRAFO
- Bus-section breaker for double busbars, A1A2_BS
- Bus-section disconnector for double busbars, A1A2_DC
- Busbar earthing switch, BB_ES
- Double CB Bay, DB_BUS_A, DB_LINE, DB_BUS_B
- 1 1/2-CB diameter, BH_LINE_A, BH_CONN, BH_LINE_B

The interlocking conditions can be altered, to meet the customer specific requirements, by adding configurable logic by means of the graphical configuration tool PCM600. The inputs Qx_EXy on the interlocking modules are used to add these specific conditions.

The input signals EXDU_xx shall be set to true if there is no transmission error at the transfer of information from other bays. Required signals with designations ending in TR are intended for transfer to other bays.

10.5 Logic rotating switch for function selection and LHMI presentation SLGGIO

10.5.1 Identification

Function description	IEC 61850 identification	IEC 60617 identification	ANSI/IEEE C37.2 device number
Logic rotating switch for function selection and LHMI presentation	SLGGIO	-	-

10.5.2 Functionality

The logic rotating switch for function selection and LHMI presentation SLGGIO (or the selector switch function block) is used to get an enhanced selector switch functionality compared to the one provided by a hardware selector switch. Hardware selector switches are used extensively by utilities, in order to have different functions operating on pre-set values. Hardware switches are however sources for maintenance issues, lower system reliability and an extended purchase portfolio. The logic selector switches eliminate all these problems.

10.5.3 Function block

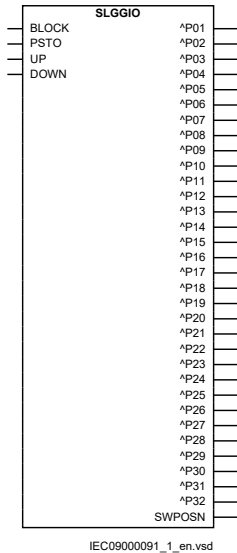

Figure 154: SLGGIO function block

10.5.4 Signals

Table 227: SLGGIO Input signals

Name	Type	Default	Description
BLOCK	BOOLEAN	0	Block of function
PSTO	INTEGER	0	Operator place selection
UP	BOOLEAN	0	Binary "UP" command
DOWN	BOOLEAN	0	Binary "DOWN" command

Table 228: SLGGIO Output signals

Name	Type	Description
P01	BOOLEAN	Selector switch position 1
P02	BOOLEAN	Selector switch position 2
P03	BOOLEAN	Selector switch position 3
P04	BOOLEAN	Selector switch position 4
P05	BOOLEAN	Selector switch position 5

Table continues on next page

Name	Type	Description
P06	BOOLEAN	Selector switch position 6
P07	BOOLEAN	Selector switch position 7
P08	BOOLEAN	Selector switch position 8
P09	BOOLEAN	Selector switch position 9
P10	BOOLEAN	Selector switch position 10
P11	BOOLEAN	Selector switch position 11
P12	BOOLEAN	Selector switch position 12
P13	BOOLEAN	Selector switch position 13
P14	BOOLEAN	Selector switch position 14
P15	BOOLEAN	Selector switch position 15
P16	BOOLEAN	Selector switch position 16
P17	BOOLEAN	Selector switch position 17
P18	BOOLEAN	Selector switch position 18
P19	BOOLEAN	Selector switch position 19
P20	BOOLEAN	Selector switch position 20
P21	BOOLEAN	Selector switch position 21
P22	BOOLEAN	Selector switch position 22
P23	BOOLEAN	Selector switch position 23
P24	BOOLEAN	Selector switch position 24
P25	BOOLEAN	Selector switch position 25
P26	BOOLEAN	Selector switch position 26
P27	BOOLEAN	Selector switch position 27
P28	BOOLEAN	Selector switch position 28
P29	BOOLEAN	Selector switch position 29
P30	BOOLEAN	Selector switch position 30
P31	BOOLEAN	Selector switch position 31
P32	BOOLEAN	Selector switch position 32
SWPOSN	INTEGER	Switch position as integer value

10.5.5 Settings

Table 229: SLGGIO Non group settings (basic)

Name	Values (Range)	Unit	Step	Default	Description
Operation	Off On	-	-	Off	Operation Off/On
NrPos	2 - 32	-	1	32	Number of positions in the switch
OutType	Pulsed Steady	-	-	Steady	Output type, steady or pulse
tPulse	0.000 - 60.000	s	0.001	0.200	Operate pulse duration
tDelay	0.000 - 60000.000	s	0.010	0.000	Output time delay
StopAtExtremes	Disabled Enabled	-	-	Disabled	Stop when min or max position is reached

10.5.6 Monitored data

Table 230: SLGGIO Monitored data

Name	Type	Values (Range)	Unit	Description
SWPOSN	INTEGER	-	-	Switch position as integer value

10.5.7 Operation principle

The logic rotating switch for function selection and LHMI presentation (SLGGIO) function has two operating inputs – UP and DOWN. When a signal is received on the UP input, the block will activate the output next to the present activated output, in ascending order (if the present activated output is 3 – for example and one operates the UP input, then the output 4 will be activated). When a signal is received on the DOWN input, the block will activate the output next to the present activated output, in descending order (if the present activated output is 3 – for example and one operates the DOWN input, then the output 2 will be activated). Depending on the output settings the output signals can be steady or pulsed. In case of steady signals, in case of UP or DOWN operation, the previously active output will be deactivated. Also, depending on the settings one can have a time delay between the UP or DOWN activation signal positive front and the output activation.

Besides the inputs visible in the application configuration in the Application Configuration tool, there are other possibilities that will allow an user to set the desired position directly (without activating the intermediate positions), either locally or remotely, using a “select before execute” dialog. One can block the function operation, by activating the BLOCK input. In this case, the present position will be kept and further operation will be blocked. The operator place (local or remote) is specified through the PSTO input. If any operation is allowed the signal INTONE from the Fixed signal function block can be connected. SLGGIO function block has also an integer value output, that generates the actual position number. The positions and the block names are fully settable by the user. These names will appear in the menu, so the user can see the position names instead of a number.

10.6 Selector mini switch VSGGIO

10.6.1 Identification

Function description	IEC 61850 identification	IEC 60617 identification	ANSI/IEEE C37.2 device number
Selector mini switch	VSGGIO	-	-

10.6.2 Functionality

The Selector mini switch VSGGIO function block is a multipurpose function used for a variety of applications, as a general purpose switch.

VSGGIO can be controlled from the menu or from a symbol on the single line diagram (SLD) on the local HMI.

10.6.3 Function block

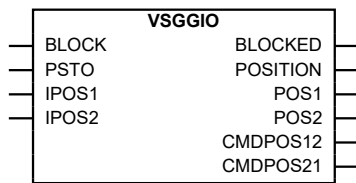

IEC09000341-1-en.vsd

10.6.4 Signals

Table 231: VSGGIO Input signals

Name	Type	Default	Description
BLOCK	BOOLEAN	0	Block of function
PSTO	INTEGER	0	Operator place selection
IPOS1	BOOLEAN	0	Position 1 indicating input
IPOS2	BOOLEAN	0	Position 2 indicating input

Table 232: VSGGIO Output signals

Name	Type	Description
BLOCKED	BOOLEAN	The function is active but the functionality is blocked
POSITION	INTEGER	Position indication, integer
POS1	BOOLEAN	Position 1 indication, logical signal
POS2	BOOLEAN	Position 2 indication, logical signal
CMDPOS12	BOOLEAN	Execute command from position 1 to position 2
CMDPOS21	BOOLEAN	Execute command from position 2 to position 1

10.6.5 Settings

Table 233: VSGGIO Non group settings (basic)

Name	Values (Range)	Unit	Step	Default	Description
Operation	Off On	-	-	Off	Operation Off / On
CtlModel	Dir Norm SBO Enh	-	-	Dir Norm	Specifies the type for control model according to IEC 61850
Mode	Steady Pulsed	-	-	Pulsed	Operation mode
tSelect	0.000 - 60.000	s	0.001	30.000	Max time between select and execute signals
tPulse	0.000 - 60.000	s	0.001	0.200	Command pulse length

10.6.6 Operation principle

Selector mini switch (VSGGIO) function can be used for double purpose, in the same way as switch controller (SCSWI) functions are used:

- for indication on the single line diagram (SLD). Position is received through the IPOS1 and IPOS2 inputs and distributed in the configuration through the POS1 and POS2 outputs, or to IEC 61850 through reporting, or GOOSE.
- for commands that are received via the local HMI or IEC 61850 and distributed in the configuration through outputs CMDPOS12 and CMDPOS21.
The output CMDPOS12 is set when the function receives a CLOSE command from the local HMI when the SLD is displayed and the object is chosen.
The output CMDPOS21 is set when the function receives an OPEN command from the local HMI when the SLD is displayed and the object is chosen.



It is important for indication in the SLD that the a symbol is associated with a controllable object, otherwise the symbol won't be displayed on the screen. A symbol is created and configured in GDE tool in PCM600.

The PSTO input is connected to the Local remote switch to have a selection of operators place, operation from local HMI (Local) or through IEC 61850 (Remote). An INTONE connection from Fixed signal function block (FXDSIGN) will allow operation from local HMI.

As it can be seen, both indications and commands are done in double-bit representation, where a combination of signals on both inputs/outputs generate the desired result.

The following table shows the relationship between IPOS1/IPOS2 inputs and the name of the string that is shown on the SLD. The value of the strings are set in PST.

IPOS1	IPOS2	Name of displayed string	Default string value
0	0	PosUndefined	P00
1	0	Position1	P01
0	1	Position2	P10
1	1	PosBadState	P11

10.7 IEC 61850 generic communication I/O functions DPGGIO

10.7.1 Identification

Function description	IEC 61850 identification	IEC 60617 identification	ANSI/IEEE C37.2 device number
IEC 61850 generic communication I/O functions	DPGGIO	-	-

10.7.2 Functionality

The IEC 61850 generic communication I/O functions DPGGIO function block is used to send double indications to other systems or equipment in the substation using IEC61850. It is especially used in the interlocking and reservation station-wide logics.

10.7.3 Function block

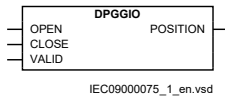

Figure 155: DPGGIO function block

10.7.4 Signals

Table 234: DPGGIO Input signals

Name	Type	Default	Description
OPEN	BOOLEAN	0	Open indication
CLOSE	BOOLEAN	0	Close indication
VALID	BOOLEAN	0	Valid indication

Table 235: DPGGIO Output signals

Name	Type	Description
POSITION	INTEGER	Double point indication

10.7.5 Settings

The function does not have any parameters available in Local HMI or Protection and Control IED Manager (PCM600).

10.7.6 Operation principle

Upon receiving the input signals, the IEC 61850 generic communication I/O functions (DPGGIO) function block will send the signals over IEC 61850-8-1 to the equipment or system that requests these signals. To be able to get the signals, PCM600 must be used to define which function block in which equipment or system should receive this information.

10.8 Single point generic control 8 signals SPC8GGIO

10.8.1 Identification

Function description	IEC 61850 identification	IEC 60617 identification	ANSI/IEEE C37.2 device number
Single point generic control 8 signals	SPC8GGIO	-	-

10.8.2 Functionality

The Single point generic control 8 signals SPC8GGIO function block is a collection of 8 single point commands, designed to bring in commands from REMOTE (SCADA) to those parts of the logic configuration that do not need extensive command receiving functionality (for example, SCSWI). In this way, simple commands can be sent directly to the IED outputs, without confirmation. The commands can be pulsed or steady with a settable pulse time.

10.8.3 Function block

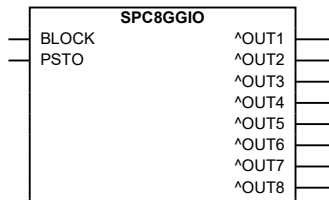

IEC09000086_1_en.vsd

Figure 156: SPC8GGIO function block

10.8.4 Signals

Table 236: SPC8GGIO Input signals

Name	Type	Default	Description
BLOCK	BOOLEAN	0	Block of function
PSTO	INTEGER	2	Operator place selection

Table 237: SPC8GGIO Output signals

Name	Type	Description
OUT1	BOOLEAN	Output 1
OUT2	BOOLEAN	Output 2
OUT3	BOOLEAN	Output 3
OUT4	BOOLEAN	Output 4
OUT5	BOOLEAN	Output 5
OUT6	BOOLEAN	Output 6
OUT7	BOOLEAN	Output 7
OUT8	BOOLEAN	Output 8

10.8.5 Settings

Table 238: SPC8GGIO Non group settings (basic)

Name	Values (Range)	Unit	Step	Default	Description
Operation	Off On	-	-	Off	Operation Off/On
Latched1	Pulsed Latched	-	-	Pulsed	Setting for pulsed/latched mode for output 1
tPulse1	0.01 - 6000.00	s	0.01	0.10	Output 1 Pulse Time
Latched2	Pulsed Latched	-	-	Pulsed	Setting for pulsed/latched mode for output 2
tPulse2	0.01 - 6000.00	s	0.01	0.10	Output 2 Pulse Time
Latched3	Pulsed Latched	-	-	Pulsed	Setting for pulsed/latched mode for output 3
tPulse3	0.01 - 6000.00	s	0.01	0.10	Output 3 Pulse Time
Latched4	Pulsed Latched	-	-	Pulsed	Setting for pulsed/latched mode for output 4
tPulse4	0.01 - 6000.00	s	0.01	0.10	Output 4 Pulse Time
Latched5	Pulsed Latched	-	-	Pulsed	Setting for pulsed/latched mode for output 5
tPulse5	0.01 - 6000.00	s	0.01	0.10	Output 5 Pulse Time
Latched6	Pulsed Latched	-	-	Pulsed	Setting for pulsed/latched mode for output 6
tPulse6	0.01 - 6000.00	s	0.01	0.10	Output 6 Pulse Time
Latched7	Pulsed Latched	-	-	Pulsed	Setting for pulsed/latched mode for output 7
tPulse7	0.01 - 6000.00	s	0.01	0.10	Output 7 Pulse Time
Latched8	Pulsed Latched	-	-	Pulsed	Setting for pulsed/latched mode for output 8
tPulse8	0.01 - 6000.00	s	0.01	0.10	Output 8 pulse time

10.8.6 Operation principle

The PSTO input selects the operator place (LOCAL, REMOTE or ALL). One of the eight outputs is activated based on the command sent from the operator place selected. The settings *Latchedx* and *tPulsedx* (where x is the respective output) will determine if the signal will be pulsed (and how long the pulse is) or latched (steady). BLOCK will block the operation of the function – in case a command is sent, no output will be activated.



PSTO is the universal operator place selector for all control functions. Although, PSTO can be configured to use LOCAL or ALL operator places only, REMOTE operator place is used in SPC8GGIO function.

10.9 Automation bits AUTOBITS

10.9.1 Identification

Function description	IEC 61850 identification	IEC 60617 identification	ANSI/IEEE C37.2 device number
AutomationBits, command function for DNP3	AUTOBITS	-	-

10.9.2 Functionality

The Automation bits function AUTOBITS is used to configure the DNP3 protocol command handling. Each of the 3 AUTOBITS available has 32 individual outputs available, each can be mapped as a binary output point in DNP3.

10.9.3 Function block

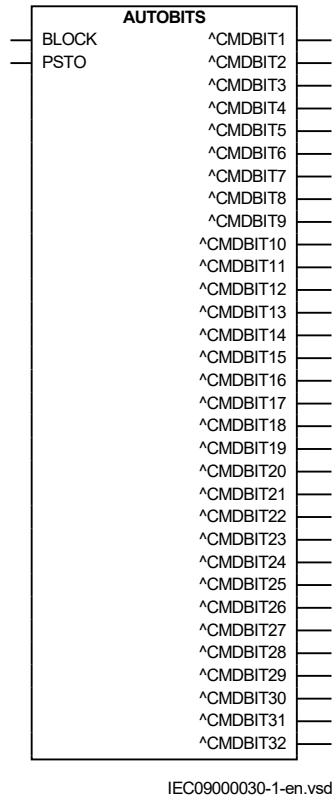

Figure 157: AUTOBITS function block

10.9.4 Signals

Table 239: AUTOBITS Input signals

Name	Type	Default	Description
BLOCK	BOOLEAN	0	Block of function
PSTO	INTEGER	0	Operator place selection

Table 240: AUTOBITS Output signals

Name	Type	Description
CMDBIT1	BOOLEAN	Command out bit 1
CMDBIT2	BOOLEAN	Command out bit 2
CMDBIT3	BOOLEAN	Command out bit 3
CMDBIT4	BOOLEAN	Command out bit 4
CMDBIT5	BOOLEAN	Command out bit 5
CMDBIT6	BOOLEAN	Command out bit 6
CMDBIT7	BOOLEAN	Command out bit 7
CMDBIT8	BOOLEAN	Command out bit 8
CMDBIT9	BOOLEAN	Command out bit 9
CMDBIT10	BOOLEAN	Command out bit 10
CMDBIT11	BOOLEAN	Command out bit 11
CMDBIT12	BOOLEAN	Command out bit 12
CMDBIT13	BOOLEAN	Command out bit 13
CMDBIT14	BOOLEAN	Command out bit 14
CMDBIT15	BOOLEAN	Command out bit 15
CMDBIT16	BOOLEAN	Command out bit 16
CMDBIT17	BOOLEAN	Command out bit 17
CMDBIT18	BOOLEAN	Command out bit 18
CMDBIT19	BOOLEAN	Command out bit 19
CMDBIT20	BOOLEAN	Command out bit 20
CMDBIT21	BOOLEAN	Command out bit 21
CMDBIT22	BOOLEAN	Command out bit 22
CMDBIT23	BOOLEAN	Command out bit 23
CMDBIT24	BOOLEAN	Command out bit 24
CMDBIT25	BOOLEAN	Command out bit 25
CMDBIT26	BOOLEAN	Command out bit 26
CMDBIT27	BOOLEAN	Command out bit 27
CMDBIT28	BOOLEAN	Command out bit 28
CMDBIT29	BOOLEAN	Command out bit 29
CMDBIT30	BOOLEAN	Command out bit 30
CMDBIT31	BOOLEAN	Command out bit 31
CMDBIT32	BOOLEAN	Command out bit 32

10.9.5 Settings

Table 241: AUTOBITS Non group settings (basic)

Name	Values (Range)	Unit	Step	Default	Description
Operation	Off On	-	-	Off	Operation Off / On

10.9.6 Operation principle

Automation bits function (AUTOBITS) has 32 individual outputs which each can be mapped as a Binary Output point in DNP3. The output is operated by a "Object 12" in DNP3. This object contains parameters for control-code, count, on-time and off-time. To operate an AUTOBITS output point, send a control-code of latch-On, latch-Off, pulse-On, pulse-Off, Trip or Close. The remaining parameters will be regarded were appropriate. ex: pulse-On, on-time=100, off-time=300, count=5 would give 5 positive 100 ms pulses, 300 ms apart.

There is a BLOCK input signal, which will disable the operation of the function, in the same way the setting *Operation: On/Off* does. That means that, upon activation of the BLOCK input, all 32 CMDBITxx outputs will be set to 0. The BLOCK acts like an overriding, the function still receives data from the DNP3 master. Upon deactivation of BLOCK, all the 32 CMDBITxx outputs will be set by the DNP3 master again, momentarily. For AUTOBITS, the PSTO input determines the operator place. The command can be written to the block while in "Remote". If PSTO is in "Local" then no change is applied to the outputs.

For description of the DNP3 protocol implementation, refer to DNP3 communication protocol manual.

10.10 Function commands for IEC 60870-5-103 I103CMD

10.10.1 Functionality

I103CMD is a command function block in control direction with pre-defined output signals. The signals are in steady state, not pulsed, and stored in the IED in case of restart.

10.10.2 Function block

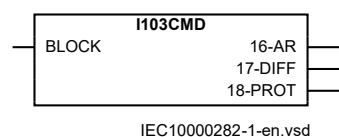

Figure 158: I103CMD function block

10.10.3 Signals

Table 242: I103CMD Input signals

Name	Type	Default	Description
BLOCK	BOOLEAN	0	Block of commands

Table 243: I103CMD Output signals

Name	Type	Description
16-AR	BOOLEAN	Information number 16, off/on of autorecloser
17-DIFF	BOOLEAN	Information number 17, block of differential protection
18-PROT	BOOLEAN	Information number 18, block of protection

10.10.4 Settings

Table 244: I103CMD Non group settings (basic)

Name	Values (Range)	Unit	Step	Default	Description
FunctionType	1 - 255	-	1	1	Function type (1-255)

10.11 IED commands for IEC 60870-5-103 I103IEDCMD

10.11.1 Functionality

I103IEDCMD is a command block in control direction with defined IED functions. All outputs are pulsed and they are NOT stored. Pulse length is fixed to 400ms.

10.11.2 Function block

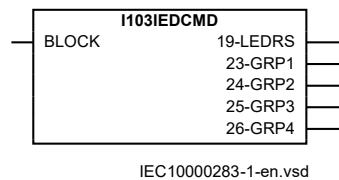

Figure 159: I103IEDCMD function block

10.11.3 Signals

Table 245: I103IEDCMD Input signals

Name	Type	Default	Description
BLOCK	BOOLEAN	0	Block of commands

Table 246: I103IEDCMD Output signals

Name	Type	Description
19-LEDRS	BOOLEAN	Information number 19, reset LEDs
23-GRP1	BOOLEAN	Information number 23, activate setting group 1
24-GRP2	BOOLEAN	Information number 24, activate setting group 2
25-GRP3	BOOLEAN	Information number 25, activate setting group 3
26-GRP4	BOOLEAN	Information number 26, activate setting group 4

10.11.4 Settings

Table 247: I103IEDCMD Non group settings (basic)

Name	Values (Range)	Unit	Step	Default	Description
FunctionType	1 - 255	-	1	255	Function type (1-255)

10.12 Function commands user defined for IEC 60870-5-103 I103USRCMD

10.12.1 Functionality

I103USRCMD is a command block in control direction with user defined output signals. These function blocks include the *FunctionType* parameter for each block in the private range, and the Information number parameter for each output signal.

10.12.2 Function block

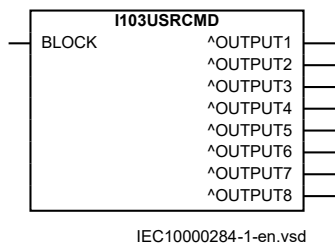

Figure 160: I103USRCMD function block

10.12.3 Signals

Table 248: I103USRCMD Input signals

Name	Type	Default	Description
BLOCK	BOOLEAN	0	Block of commands

Table 249: I103USRCMD Output signals

Name	Type	Description
OUTPUT1	BOOLEAN	Command output 1
OUTPUT2	BOOLEAN	Command output 2
OUTPUT3	BOOLEAN	Command output 3
OUTPUT4	BOOLEAN	Command output 4
OUTPUT5	BOOLEAN	Command output 5
OUTPUT6	BOOLEAN	Command output 6
OUTPUT7	BOOLEAN	Command output 7
OUTPUT8	BOOLEAN	Command output 8

10.12.4 Settings

Table 250: I103USRCMD Non group settings (basic)

Name	Values (Range)	Unit	Step	Default	Description
FunctionType	1 - 255	-	1	1	Function type (1-255)
PulseMode	Steady Pulsed	-	-	Pulsed	Pulse mode
PulseLength	0.200 - 60.000	s	0.001	0.400	Pulse length
InfNo_1	1 - 255	-	1	1	Information number for output 1 (1-255)
InfNo_2	1 - 255	-	1	2	Information number for output 2 (1-255)
InfNo_3	1 - 255	-	1	3	Information number for output 3 (1-255)
InfNo_4	1 - 255	-	1	4	Information number for output 4 (1-255)
InfNo_5	1 - 255	-	1	5	Information number for output 5 (1-255)
InfNo_6	1 - 255	-	1	6	Information number for output 6 (1-255)
InfNo_7	1 - 255	-	1	7	Information number for output 7 (1-255)
InfNo_8	1 - 255	-	1	8	Information number for output 8 (1-255)

10.13 Function commands generic for IEC 60870-5-103 I103GENCMD

10.13.1 Functionality

I103GENCMD is used for transmitting generic commands over IEC 60870-5-103. The function has two outputs signals CMD_OFF and CMD_ON that can be used to implement double-point command schemes.

The I103GENCMD component can be configured as either 2 pulsed ON/OFF or 2 steady ON/OFF outputs. The ON output is pulsed with a command with value 2, while the OFF output is pulsed with a command value 1. If in steady mode is ON asserted and OFF deasserted with command 2 and vice versa with command 1. The I103GENCMD is retained, and a command in steady mode will be reissued on restart.

The standard does not define the use of values 0 and 3. However, when connected to a switching device, these values are transmitted.

10.13.2 Function block

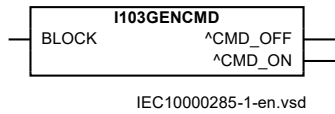

Figure 161: I103GENCMD function block

10.13.3 Signals

Table 251: I103GENCMD Input signals

Name	Type	Default	Description
BLOCK	BOOLEAN	0	Block of command

Table 252: I103GENCMD Output signals

Name	Type	Description
CMD_OFF	BOOLEAN	Command output OFF
CMD_ON	BOOLEAN	Command output ON

10.13.4 Settings

Table 253: I103GENCMD Non group settings (basic)

Name	Values (Range)	Unit	Step	Default	Description
FunctionType	1 - 255	-	1	1	Function type (1-255)
PulseLength	0.000 - 60.000	s	0.001	0.400	Pulse length
InfNo	1 - 255	-	1	1	Information number for command output (1-255)

10.14 IED commands with position and select for IEC 60870-5-103 I103POSCMD

10.14.1 Functionality

I103POSCMD has double-point position indicators that are getting the position value as an integer (for example from the POSITION output of the SCSWI function block) and sending it over IEC 60870-5-103 (1=OPEN; 2=CLOSE). The standard does not define the use of values 0 and 3. However, when connected to a switching device, these values are transmitted.

The BLOCK input will block only the signals in monitoring direction (the position information), not the commands via IEC 60870-5-103. The SELECT input is used to indicate that the monitored apparatus has been selected (in a select-before-operate type of control)

10.14.2 Function block

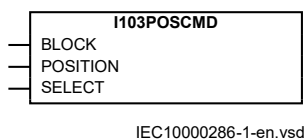

Figure 162: I103POSCMD function block

10.14.3 Signals

Table 254: I103POSCMD Input signals

Name	Type	Default	Description
BLOCK	BOOLEAN	0	Block of command
POSITION	INTEGER	0	Position of controllable object
SELECT	BOOLEAN	0	Select of controllable object

10.14.4 Settings

Table 255: I103POSCMD Non group settings (basic)

Name	Values (Range)	Unit	Step	Default	Description
FunctionType	1 - 255	-	1	1	Fucntion type (1-255)
InfNo	160 - 196	-	4	160	Information number for command output (1-255)

Section 11 Logic

11.1 Tripping logic common 3-phase output SMPPTRC

11.1.1 Identification

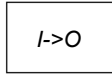
Function description	IEC 61850 identification	IEC 60617 identification	ANSI/IEEE C37.2 device number
Tripping logic common 3-phase output	SMPPTRC		94

11.1.2 Functionality

A function block for protection tripping is provided for each circuit breaker involved in the tripping of the fault. It provides a settable pulse prolongation to ensure a three-phase trip pulse of sufficient length, as well as all functionality necessary for correct co-operation with autoreclosing functions.

The trip function block also includes a settable latch functionality for breaker lock-out.

11.1.3 Function block

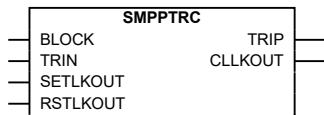

IEC09000284_1_en.vsd

Figure 163: SMPPTRC function block

11.1.4 Signals

Table 256: SMPPTRC Input signals

Name	Type	Default	Description
BLOCK	BOOLEAN	0	Block of function
TRIN	BOOLEAN	0	Trip all phases
SETLKOUT	BOOLEAN	0	Input for setting the circuit breaker lockout function
RSTLKOUT	BOOLEAN	0	Input for resetting the circuit breaker lockout function

Table 257: SMPPTRC Output signals

Name	Type	Description
TRIP	BOOLEAN	General trip signal
CLLKOUT	BOOLEAN	Circuit breaker lockout output (set until reset)

11.1.5 Settings

Table 258: SMPPTRC Group settings (basic)

Name	Values (Range)	Unit	Step	Default	Description
Operation	Off On	-	-	On	Operation Off / On
tTripMin	0.000 - 60.000	s	0.001	0.150	Minimum duration of trip output signal

Table 259: SMPPTRC Group settings (advanced)

Name	Values (Range)	Unit	Step	Default	Description
TripLockout	Off On	-	-	Off	On: Activate output (CLLKOUT) and trip latch, Off: Only output
AutoLock	Off On	-	-	Off	On: Lockout from input (SETLKOUT) and trip, Off: Only input

11.1.6 Operation principle

The duration of a trip output signal from tripping logic common 3-phase output SMPPTRC is settable (*tTripMin*). The pulse length should be long enough to secure the breaker opening.

For three-phase tripping logic common 3-phase output, SMPPTRC has a single input (TRIN) through which all trip output signals from the protection functions within the IED, or from external protection functions via one or more of the IEDs binary inputs, are routed. It has a single trip output (TRIP) for connection to one or more of the IEDs binary outputs, as well as to other functions within the IED requiring this signal.

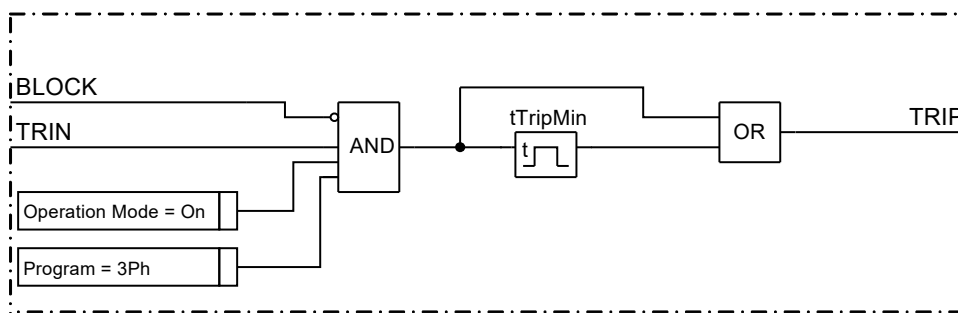

en05000789.vsd

Figure 164: Simplified logic diagram for three phase trip

In multi-breaker arrangements, one SMPPTRC function block is used for each breaker.

Lockout can be activated either by activating the input (SETLKOUT) or automatically from trip input by setting *AutoLock* to *On*. A Lockout condition will be indicated by activation of the

output (CLKOUT). If lockout has been activated it can be reset by activating the input (RSTLKOUT) or via the HMI.

If *TripLockout* is set to *On* an active Lockout will result in a three-phase trip output. In this way if both *AutoLock* and *TripLockout* are set to *On* the trip will always be three-phase and sealed in.

11.1.7 Technical data

Table 260: SMPPTRC technical data

Function	Range or value	Accuracy
Trip action	3-ph	-
Timers	(0.000-60.000) s	± 0.5% ± 10 ms

11.2 Trip matrix logic TMAGGIO

11.2.1 Identification

Function description	IEC 61850 identification	IEC 60617 identification	ANSI/IEEE C37.2 device number
Trip matrix logic	TMAGGIO	-	-

11.2.2 Functionality

The 12 Trip matrix logic TMAGGIO function each with 32 inputs are used to route trip signals and other logical output signals to the tripping logics SMPPTRC and SPTPTRC or to different output contacts on the IED.

TMAGGIO 3 output signals and the physical outputs allows the user to adapt the signals to the physical tripping outputs according to the specific application needs for settable pulse or steady output.

11.2.3 Function block

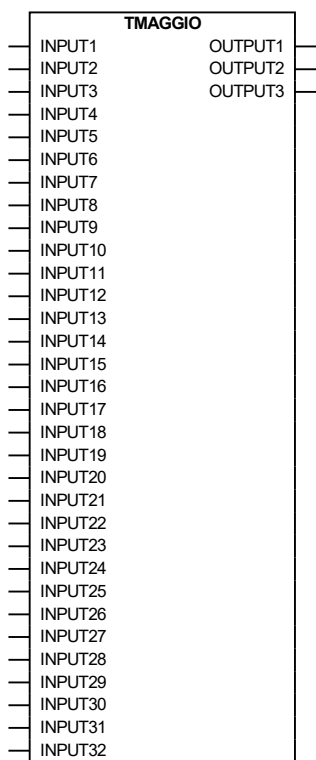

Figure 165: TMAGGIO function block

11.2.4 Signals

Table 261: TMAGGIO Input signals

Name	Type	Default	Description
INPUT1	BOOLEAN	0	Binary input 1
INPUT2	BOOLEAN	0	Binary input 2
INPUT3	BOOLEAN	0	Binary input 3
INPUT4	BOOLEAN	0	Binary input 4
INPUT5	BOOLEAN	0	Binary input 5
INPUT6	BOOLEAN	0	Binary input 6
INPUT7	BOOLEAN	0	Binary input 7
INPUT8	BOOLEAN	0	Binary input 8
INPUT9	BOOLEAN	0	Binary input 9
INPUT10	BOOLEAN	0	Binary input 10
INPUT11	BOOLEAN	0	Binary input 11
INPUT12	BOOLEAN	0	Binary input 12
INPUT13	BOOLEAN	0	Binary input 13
INPUT14	BOOLEAN	0	Binary input 14
INPUT15	BOOLEAN	0	Binary input 15
INPUT16	BOOLEAN	0	Binary input 16
Table continues on next page			

Name	Type	Default	Description
INPUT17	BOOLEAN	0	Binary input 17
INPUT18	BOOLEAN	0	Binary input 18
INPUT19	BOOLEAN	0	Binary input 19
INPUT20	BOOLEAN	0	Binary input 20
INPUT21	BOOLEAN	0	Binary input 21
INPUT22	BOOLEAN	0	Binary input 22
INPUT23	BOOLEAN	0	Binary input 23
INPUT24	BOOLEAN	0	Binary input 24
INPUT25	BOOLEAN	0	Binary input 25
INPUT26	BOOLEAN	0	Binary input 26
INPUT27	BOOLEAN	0	Binary input 27
INPUT28	BOOLEAN	0	Binary input 28
INPUT29	BOOLEAN	0	Binary input 29
INPUT30	BOOLEAN	0	Binary input 30
INPUT31	BOOLEAN	0	Binary input 31
INPUT32	BOOLEAN	0	Binary input 32

Table 262: TMAGGIO Output signals

Name	Type	Description
OUTPUT1	BOOLEAN	OR function between inputs 1 to 16
OUTPUT2	BOOLEAN	OR function between inputs 17 to 32
OUTPUT3	BOOLEAN	OR function between inputs 1 to 32

11.2.5 Settings

Table 263: TMAGGIO Group settings (basic)

Name	Values (Range)	Unit	Step	Default	Description
Operation	Off On	-	-	On	Operation Off / On
PulseTime	0.050 - 60.000	s	0.001	0.150	Output pulse time
OnDelay	0.000 - 60.000	s	0.001	0.000	Output on delay time
OffDelay	0.000 - 60.000	s	0.001	0.000	Output off delay time
ModeOutput1	Steady Pulsed	-	-	Steady	Mode for output 1, steady or pulsed
ModeOutput2	Steady Pulsed	-	-	Steady	Mode for output 2, steady or pulsed
ModeOutput3	Steady Pulsed	-	-	Steady	Mode for output 3, steady or pulsed

11.2.6 Operation principle

The trip matrix logic (TMAGGIO) block is provided with 32 input signals and 3 output signals. The function block incorporates internal logic OR gates in order to provide grouping of connected input signals to the three output signals from the function block.

Internal built-in OR logic is made in accordance with the following three rules:

1. when any one of first 16 inputs signals (INPUT1 to INPUT16) has logical value 1 the first output signal (OUTPUT1) will get logical value 1.
2. when any one of second 16 inputs signals (INPUT17 to INPUT32) has logical value 1 the second output signal (OUTPUT2) will get logical value 1.
3. when any one of all 32 input signals (INPUT1 to INPUT32) has logical value 1 the third output signal (OUTPUT3) will get logical value 1.

By use of the settings *ModeOutput1*, *ModeOutput2*, *ModeOutput3*, *PulseTime*, *OnDelay* and *OffDelay* the behavior of each output can be customized. The *OnDelay* is always active and will delay the input to output transition by the set time. The *ModeOutput* for respective output decides whether the output shall be steady with an drop-off delay as set by *OffDelay* or if it shall give a pulse with duration set by *PulseTime*. Note that for pulsed operation and that the inputs are connected in an OR-function, a new pulse will only be given on the output if all related inputs are reset and then one is activated again. For steady operation the *OffDelay* will start when all related inputs have reset. Detailed logical diagram is shown in figure 166

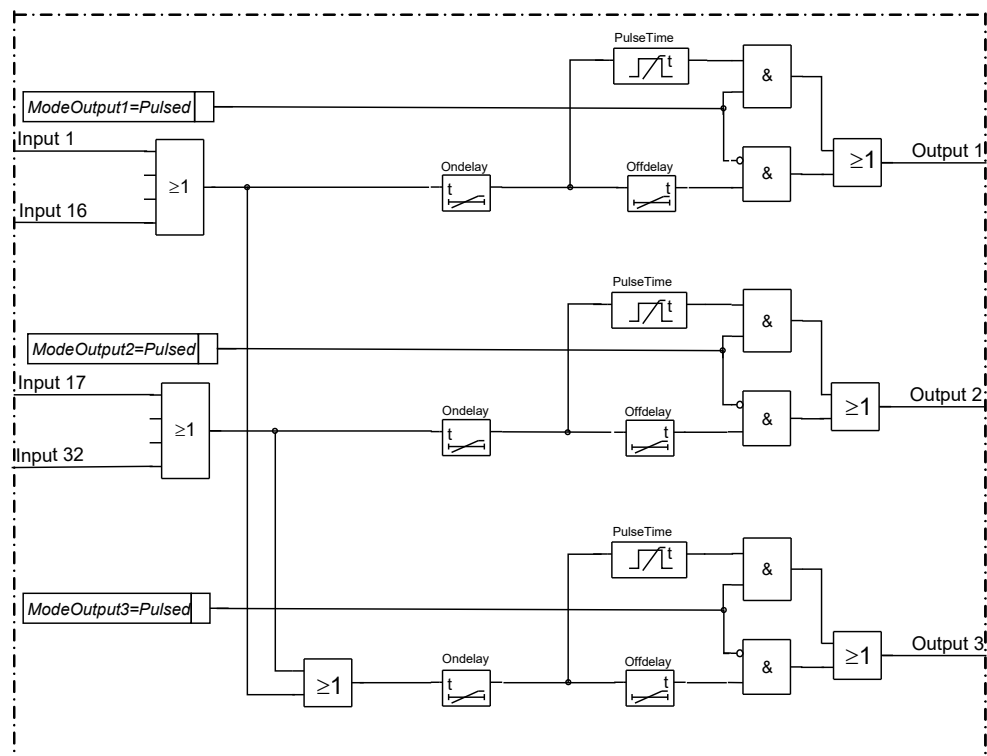

IEC09000612_2_en.vsd

Figure 166: Trip matrix internal logic

Output signals from TMAGGIO are typically connected to other logic blocks or directly to output contacts in the IED. When used for direct tripping of the circuit breaker(s) the pulse time delay shall be set to approximately 0.150 seconds in order to obtain satisfactory minimum duration of the trip pulse to the circuit breaker trip coils.

11.3 Configurable logic blocks

11.3.1 Standard configurable logic blocks

11.3.1.1 Functionality

A number of logic blocks and timers are available for the user to adapt the configuration to the specific application needs.

- **OR** function block. Each block has 6 inputs and two outputs where one is inverted.
- **INVERTER** function blocks that invert the input signal.
- **PULSETIMER** function block can be used, for example, for pulse extensions or limiting of operation of outputs, settable pulse time.
- **GATE** function block is used for whether or not a signal should be able to pass from the input to the output.
- **XOR** function block. Each block has two outputs where one is inverted.
- **LOOPDELAY** function block used to delay the output signal one execution cycle.
- **TIMERSET** function has pick-up and drop-out delayed outputs related to the input signal. The timer has a settable time delay and must be On for the input signal to activate the output with the appropriate time delay.
- **AND** function block. Each block has four inputs and two outputs where one is inverted
- **SRMEMORY** function block is a flip-flop that can set or reset an output from two inputs respectively. Each block has two outputs where one is inverted. The memory setting controls if the block's output should reset or return to the state it was, after a power interruption. The **SET** input has priority if both **SET** and **RESET** inputs are operated simultaneously.
- **RSMEMORY** function block is a flip-flop that can reset or set an output from two inputs respectively. Each block has two outputs where one is inverted. The memory setting controls if the block's output should reset or return to the state it was, after a power interruption. The **RESET** input has priority if both **SET** and **RESET** are operated simultaneously.

Configurable logic Q/T

A number of logic blocks and timers, with the capability to propagate timestamp and quality of the input signals, are available. The function blocks assist the user to adapt the IEDs configuration to the specific application needs.

- **ORQT** OR function block that also propagates timestamp and quality of input signals. Each block has six inputs and two outputs where one is inverted.
- **INVERTERQT** function block that inverts the input signal and propagates timestamp and quality of input signal.

- **PULSETIMERQT** Pulse timer function block can be used, for example, for pulse extensions or limiting of operation of outputs. The function also propagates timestamp and quality of input signal.
- **XORQT** XOR function block. The function also propagates timestamp and quality of input signals. Each block has two outputs where one is inverted.
- **TIMERSETQT** function has pick-up and drop-out delayed outputs related to the input signal. The timer has a settable time delay. The function also propagates timestamp and quality of input signal.
- **ANDQT** AND function block. The function also propagates timestamp and quality of input signals. Each block has four inputs and two outputs where one is inverted.
- **SRMEMORYQT** function block is a flip-flop that can set or reset an output from two inputs respectively. Each block has two outputs where one is inverted. The memory setting controls if the block after a power interruption should return to the state before the interruption, or be reset. The function also propagates timestamp and quality of input signal.
- **RSMEMORYQT** function block is a flip-flop that can reset or set an output from two inputs respectively. Each block has two outputs where one is inverted. The memory setting controls if the block after a power interruption should return to the state before the interruption, or be reset. The function also propagates timestamp and quality of input signal.
- **INVALIDQT** function which sets quality invalid of outputs according to a "valid" input. Inputs are copied to outputs. If input VALID is 0, or if its quality invalid bit is set, all outputs invalid quality bit will be set to invalid. The timestamp of an output will be set to the latest timestamp of INPUT and VALID inputs.
- **INDCOMBSPQT** combines single input signals to group signal. Single position input is copied to value part of SP_OUT output. TIME input is copied to time part of SP_OUT output. Quality input bits are copied to the corresponding quality part of SP_OUT output.
- **INDEXTSPQT** extracts individual signals from a group signal input. Value part of single position input is copied to SI_OUT output. Time part of single position input is copied to TIME output. Quality bits in common part and indication part of inputs signal is copied to the corresponding quality output.

11.3.1.2 OR function block

Identification

Function description	IEC 61850 identification	IEC 60617 identification	ANSI/IEEE C37.2 device number
OR Function block	OR	-	-

Functionality

The OR function is used to form general combinatory expressions with boolean variables. The OR function block has six inputs and two outputs. One of the outputs is inverted.

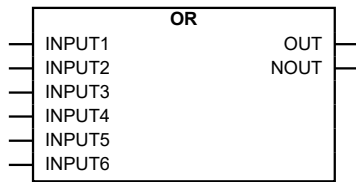
Function block

IEC09000288-1-en.vsd

*Figure 167: OR function block***Signals***Table 264: OR Input signals*

Name	Type	Default	Description
INPUT1	BOOLEAN	0	Input signal 1
INPUT2	BOOLEAN	0	Input signal 2
INPUT3	BOOLEAN	0	Input signal 3
INPUT4	BOOLEAN	0	Input signal 4
INPUT5	BOOLEAN	0	Input signal 5
INPUT6	BOOLEAN	0	Input signal 6

Table 265: OR Output signals

Name	Type	Description
OUT	BOOLEAN	Output signal
NOUT	BOOLEAN	Inverted output signal

Settings

The function does not have any parameters available in Local HMI or Protection and Control IED Manager (PCM600).

11.3.1.3 Inverter function block INVERTER**Identification**

Function description	IEC 61850 identification	IEC 60617 identification	ANSI/IEEE C37.2 device number
Inverter function block	INVERTER	-	-

Function block

IEC09000287-1-en.vsd

*Figure 168: INVERTER function block***Signals**

Table 266: INVERTER Input signals

Name	Type	Default	Description
INPUT	BOOLEAN	0	Input signal

Table 267: INVERTER Output signals

Name	Type	Description
OUT	BOOLEAN	Output signal

Settings

The function does not have any parameters available in Local HMI or Protection and Control IED Manager (PCM600).

11.3.1.4 PULSETIMER function block

Identification

Function description	IEC 61850 identification	IEC 60617 identification	ANSI/IEEE C37.2 device number
PULSETIMER function block	PULSETIMER	-	-

Functionality

The pulse function can be used, for example for pulse extensions or limiting of operation of outputs. The PULSETIMER has a settable length.

Function block

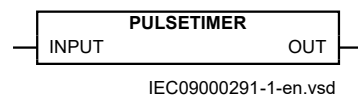

Figure 169: PULSETIMER function block

Signals

Table 268: PULSETIMER Input signals

Name	Type	Default	Description
INPUT	BOOLEAN	0	Input signal

Table 269: PULSETIMER Output signals

Name	Type	Description
OUT	BOOLEAN	Output signal

Settings

Table 270: PULSETIMER Non group settings (basic)

Name	Values (Range)	Unit	Step	Default	Description
t	0.000 - 90000.000	s	0.001	0.010	Pulse time length

11.3.1.5 Controllable gate function block GATE

Identification

Function description	IEC 61850 identification	IEC 60617 identification	ANSI/IEEE C37.2 device number
Controllable gate function block	GATE	-	-

Functionality

The GATE function block is used for controlling if a signal should pass from the input to the output or not, depending on setting.

Function block

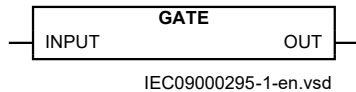

Figure 170: GATE function block

Signals

Table 271: GATE Input signals

Name	Type	Default	Description
INPUT	BOOLEAN	0	Input signal

Table 272: GATE Output signals

Name	Type	Description
OUT	BOOLEAN	Output signal

Settings

Table 273: GATE Group settings (basic)

Name	Values (Range)	Unit	Step	Default	Description
Operation	Off On	-	-	Off	Operation Off/On

11.3.1.6 Exclusive OR function block XOR

Identification

Function description	IEC 61850 identification	IEC 60617 identification	ANSI/IEEE C37.2 device number
Exclusive OR function block	XOR	-	-

Functionality

The exclusive OR function (XOR) is used to generate combinatory expressions with boolean variables. XOR has two inputs and two outputs. One of the outputs is inverted. The output signal is 1 if the input signals are different and 0 if they are the same.

Function block

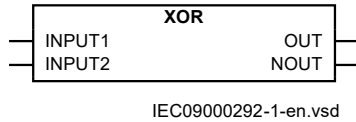

Figure 171: XOR function block

Signals

Table 274: XOR Input signals

Name	Type	Default	Description
INPUT1	BOOLEAN	0	Input signal 1
INPUT2	BOOLEAN	0	Input signal 2

Table 275: XOR Output signals

Name	Type	Description
OUT	BOOLEAN	Output signal
NOUT	BOOLEAN	Inverted output signal

Settings

The function does not have any parameters available in Local HMI or Protection and Control IED Manager (PCM600).

11.3.1.7 Loop delay function block LOOPDELAY

Function description	IEC 61850 identification	IEC 60617 identification	ANSI/IEEE C37.2 device number
Logic loop delay function block	LOOPDELAY	-	-

The Logic loop delay function block (LOOPDELAY) function is used to delay the output signal one execution cycle.

Function block

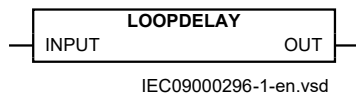

Figure 172: LOOPDELAY function block

Signals

Table 276: LOOPDELAY Input signals

Name	Type	Default	Description
INPUT	BOOLEAN	0	Input signal

Table 277: LOOPDELAY Output signals

Name	Type	Description
OUT	BOOLEAN	Output signal, signal is delayed one execution cycle

Settings

The function does not have any parameters available in Local HMI or Protection and Control IED Manager (PCM600).

11.3.1.8 Timer function block TIMERSET

Identification

Function description	IEC 61850 identification	IEC 60617 identification	ANSI/IEEE C37.2 device number
Timer function block	TIMERSET	-	-

Functionality

The function block TIMERSET has pick-up and drop-out delayed outputs related to the input signal. The timer has a settable time delay (t).

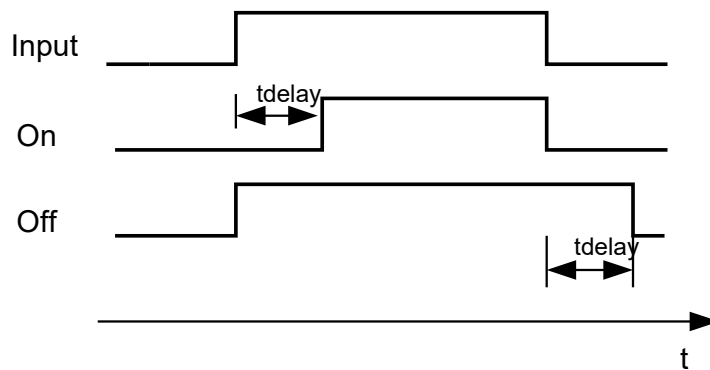

en08000289-2-en.vsd

Figure 173: TIMERSET Status diagram

Function block

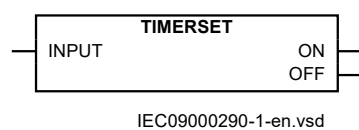

Figure 174: TIMERSET function block

Signals

Table 278: *TIMERSET* Input signals

Name	Type	Default	Description
INPUT	BOOLEAN	0	Input signal

Table 279: *TIMERSET* Output signals

Name	Type	Description
ON	BOOLEAN	Output signal, pick-up delayed
OFF	BOOLEAN	Output signal, drop-out delayed

Settings

Table 280: *TIMERSET* Group settings (basic)

Name	Values (Range)	Unit	Step	Default	Description
Operation	Off On	-	-	Off	Operation Off/On
t	0.000 - 90000.000	s	0.001	0.000	Delay for settable timer n

11.3.1.9 AND function block

Identification

Function description	IEC 61850 identification	IEC 60617 identification	ANSI/IEEE C37.2 device number
AND function block	AND	-	-

Functionality

The AND function is used to form general combinatory expressions with boolean variables. The AND function block has four inputs and two outputs.

Default value on all four inputs are logical 1 which makes it possible for the user to just use the required number of inputs and leave the rest un-connected. The output OUT has a default value 0 initially, which suppresses one cycle pulse if the function has been put in the wrong execution order.

Function block

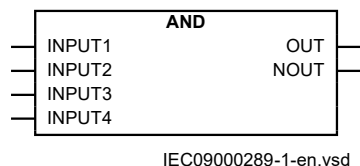

Figure 175: *AND* function block

Signals

Table 281: AND Input signals

Name	Type	Default	Description
INPUT1	BOOLEAN	1	Input signal 1
INPUT2	BOOLEAN	1	Input signal 2
INPUT3	BOOLEAN	1	Input signal 3
INPUT4	BOOLEAN	1	Input signal 4

Table 282: AND Output signals

Name	Type	Description
OUT	BOOLEAN	Output signal
NOUT	BOOLEAN	Inverted output signal

Settings

The function does not have any parameters available in Local HMI or Protection and Control IED Manager (PCM600).

11.3.1.10 Set-reset memory function block SRMEMORY

Identification

Function description	IEC 61850 identification	IEC 60617 identification	ANSI/IEEE C37.2 device number
Set-reset memory function block	SRMEMORY	-	-

Functionality

The Set-Reset function SRMEMORY is a flip-flop with memory that can set or reset an output from two inputs respectively. Each SRMEMORY function block has two outputs, where one is inverted. The memory setting controls if the flip-flop after a power interruption will return the state it had before or if it will be reset. For a Set-Reset flip-flop, SET input has higher priority over RESET input.

Table 283: Truth table for the Set-Reset (SRMEMORY) function block

SET	RESET	OUT	NOUT
1	0	1	0
0	1	0	1
1	1	1	0
0	0	0	1

Function block

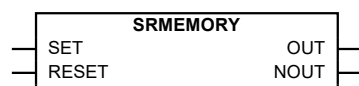

IEC09000293-1-en.vsd

Figure 176: SRMEMORY function block

Signals

Table 284: SRMEMORY Input signals

Name	Type	Default	Description
SET	BOOLEAN	0	Input signal to set
RESET	BOOLEAN	0	Input signal to reset

Table 285: SRMEMORY Output signals

Name	Type	Description
OUT	BOOLEAN	Output signal
NOUT	BOOLEAN	Inverted output signal

Settings

Table 286: SRMEMORY Group settings (basic)

Name	Values (Range)	Unit	Step	Default	Description
Memory	Off On	-	-	On	Operating mode of the memory function

11.3.1.11 Reset-set with memory function block RSMEMORY

Identification

Function description	IEC 61850 identification	IEC 60617 identification	ANSI/IEEE C37.2 device number
Reset-set with memory function block	RSMEMORY	-	-

Functionality

The Reset-set with memory function block (RSMEMORY) is a flip-flop with memory that can reset or set an output from two inputs respectively. Each RSMEMORY function block has two outputs, where one is inverted. The memory setting controls if the flip-flop after a power interruption will return the state it had before or if it will be reset. For a Reset-Set flip-flop, RESET input has higher priority over SET input.

Table 287: Truth table for RSMEMORY function block

SET	RESET	OUT	NOUT
0	0	Last value	Inverted last value
0	1	0	1
1	0	1	0
1	1	0	1

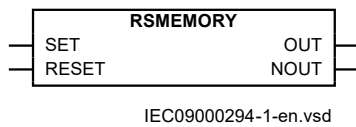
Function block*Figure 177: RSMEMORY function block***Signals***Table 288: RSMEMORY Input signals*

Name	Type	Default	Description
SET	BOOLEAN	0	Input signal to set
RESET	BOOLEAN	0	Input signal to reset

Table 289: RSMEMORY Output signals

Name	Type	Description
OUT	BOOLEAN	Output signal
NOUT	BOOLEAN	Inverted output signal

Settings*Table 290: RSMEMORY Group settings (basic)*

Name	Values (Range)	Unit	Step	Default	Description
Memory	Off On	-	-	On	Operating mode of the memory function

11.3.2 Configurable logic Q/T**11.3.2.1 Functionality**

A number of logic blocks and timers with the capability to propagate timestamp and quality of the input signals are available. The function blocks assist the user to adapt the IEDs configuration to the specific application needs.

11.3.2.2 ORQT function block**Identification**

Function description	IEC 61850 identification	IEC 60617 identification	ANSI/IEEE C37.2 device number
ORQT function block	ORQT	-	-

Functionality

ORQT function block (ORQT) is used to form general combinatory expressions with boolean variables. ORQT function block has six inputs and two outputs. One of the outputs is inverted.

Function block

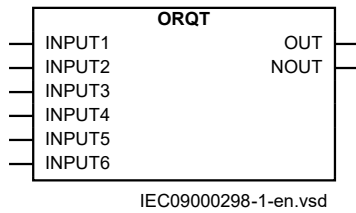

Figure 178: ORQT function block

Signals

Table 291: ORQT Input signals

Name	Type	Default	Description
INPUT1	BOOLEAN	0	Input signal 1
INPUT2	BOOLEAN	0	Input signal 2
INPUT3	BOOLEAN	0	Input signal 3
INPUT4	BOOLEAN	0	Input signal 4
INPUT5	BOOLEAN	0	Input signal 5
INPUT6	BOOLEAN	0	Input signal 6

Table 292: ORQT Output signals

Name	Type	Description
OUT	BOOLEAN	Output signal
NOUT	BOOLEAN	Inverted output signal

Settings

The function does not have any parameters available in Local HMI or Protection and Control IED Manager (PCM600).

11.3.2.3 INVERTERQT function block

Identification

Function description	IEC 61850 identification	IEC 60617 identification	ANSI/IEEE C37.2 device number
INVERTERQT function block	INVERTERQT	-	-

Function block

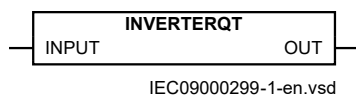

Figure 179: INVERTERQT function block

Signals

Table 293: INVERTERQT Input signals

Name	Type	Default	Description
INPUT	BOOLEAN	0	Input signal

Table 294: INVERTERQT Output signals

Name	Type	Description
OUT	BOOLEAN	Output signal

Settings

The function does not have any parameters available in Local HMI or Protection and Control IED Manager (PCM600).

11.3.2.4 Pulse timer function block PULSTIMERQT

Identification

Function description	IEC 61850 identification	IEC 60617 identification	ANSI/IEEE C37.2 device number
Pulse timer function block	PULSTIMERQT	-	-

Functionality

Pulse timer function block (PULSETIMERQT) can be used, for example, for pulse extensions or limiting of operation of outputs. The pulse timer has a settable length and will also propagate quality and time.

When the input goes to 1 the output will be 1 for the time set by the time delay parameter t . Then return to 0.

When the output changes value, the timestamp of the output signal is updated.

The supported “quality” state bits are propagated from the input each execution to the output. A change of these bits will not lead to an updated timestamp on the output.

Function block

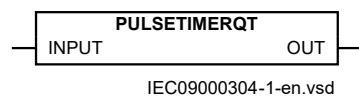

Figure 180: PULSETIMERQT function block

Signals

Table 295: PULSETIMERQT Input signals

Name	Type	Default	Description
INPUT	BOOLEAN	0	Input signal

Table 296: PULSETIMERQT Output signals

Name	Type	Description
OUT	BOOLEAN	Output signal

Settings

Table 297: PULSETIMERQT Non group settings (basic)

Name	Values (Range)	Unit	Step	Default	Description
t	0.000 - 90000.000	s	0.001	0.010	Pulse time length

11.3.2.5 XORQT function block

Identification

Function description	IEC 61850 identification	IEC 60617 identification	ANSI/IEEE C37.2 device number
XORQT function block	XORQT	-	-

Functionality

The exclusive OR function (XORQT) function is used to generate combinatory expressions with boolean variables. XORQT function has two inputs and two outputs. One of the outputs is inverted. The output signal is 1 if the input signals are different and 0 if they are equal.

Function block

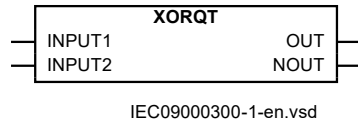

Figure 181: XORQT function block

Signals

Table 298: XORQT Input signals

Name	Type	Default	Description
INPUT1	BOOLEAN	0	Input signal 1
INPUT2	BOOLEAN	0	Input signal 2

Table 299: XORQT Output signals

Name	Type	Description
OUT	BOOLEAN	Output signal
NOUT	BOOLEAN	Inverted output signal

Settings

The function does not have any parameters available in Local HMI or Protection and Control IED Manager (PCM600).

11.3.2.6 Settable timer function block TIMERSETQT**Identification**

Function description	IEC 61850 identification	IEC 60617 identification	ANSI/IEEE C37.2 device number
Settable timer function block	TIMERSETQT	-	-

Functionality

The Settable timer function block (TIMERSETQT) has pick-up and drop-out delayed outputs related to the input signal. The timer has a settable time delay (t).

When the output changes value the timestamp of the output signal is updated. The supported “quality” state bits are propagated from the input each execution to the output. A change of these bits will not lead to an updated timestamp on the output.

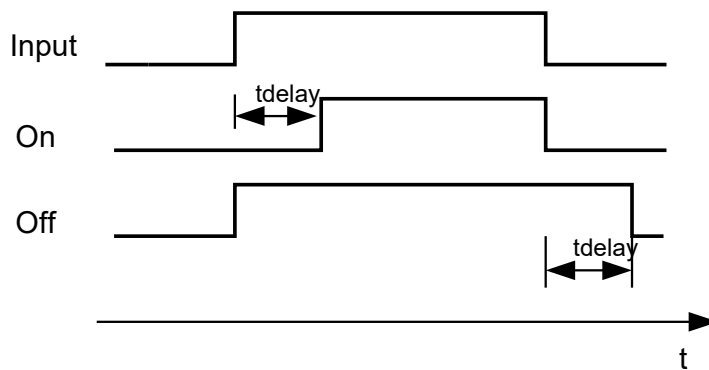

en08000289-2-en.vsd

Figure 182: TIMERSETQT function

Function block

IEC09000303-1-en.vsd

Figure 183: TIMERSETQT function block

Signals

Table 300: TIMERSETQT Input signals

Name	Type	Default	Description
INPUT	BOOLEAN	0	Input signal

Table 301: *TIMERSETQT Output signals*

Name	Type	Description
ON	BOOLEAN	Output signal, pick-up delayed
OFF	BOOLEAN	Output signal, drop-out delayed

Settings

Table 302: *TIMERSETQT Group settings (basic)*

Name	Values (Range)	Unit	Step	Default	Description
Operation	Off On	-	-	Off	Operation Off/On
t	0.000 - 90000.000	s	0.001	0.000	Delay for settable timer n

11.3.2.7 ANDQT function block

Identification

Function description	IEC 61850 identification	IEC 60617 identification	ANSI/IEEE C37.2 device number
ANDQT function block	ANDQT	-	-

Functionality

ANDQT function is used to form general combinatory expressions with boolean variables. ANDQT function block has four inputs and two outputs.

Default value on all four inputs are logical 1 which makes it possible for the user to just use the required number of inputs and leave the rest un-connected. The output OUT has a default value 0 initially, which will suppress one cycle pulse if the function has been put in the wrong execution order.

Function block

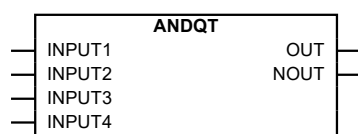

IEC09000297-1-en.vsd

Figure 184: *ANDQT function block*

Signals

Table 303: *ANDQT Input signals*

Name	Type	Default	Description
INPUT1	BOOLEAN	1	Input signal 1
INPUT2	BOOLEAN	1	Input signal 2
INPUT3	BOOLEAN	1	Input signal 3
INPUT4	BOOLEAN	1	Input signal 4

Table 304: ANDQT Output signals

Name	Type	Description
OUT	BOOLEAN	Output signal
NOUT	BOOLEAN	Inverted output signal

Settings

The function does not have any parameters available in Local HMI or Protection and Control IED Manager (PCM600).

11.3.2.8 Set-reset function block SRMEMORYQT

Identification

Function description	IEC 61850 identification	IEC 60617 identification	ANSI/IEEE C37.2 device number
Set/reset logic component	SRMEMORYQT	-	-

Functionality

The Set-reset function (SRMEMORYQT) is a flip-flop with memory that can set or reset an output from two inputs respectively. Each SRMEMORYQT function block has two outputs, where one is inverted. The memory setting controls if the flip-flop after a power interruption will return the state it had before or if it will be reset.

SRMEMORYQT propagates quality and time as well as value.

Table 305: Truth table for SRMEMORYQT function block

SET	RESET	OUT	NOUT
0	0	Last value	Inverted last value
0	1	0	1
1	0	1	0
1	1	1	0

If *Memory* parameter is *On*, the output result is stored in semi-retained memory.

Function block

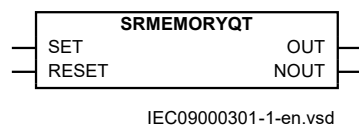

Figure 185: SRMEMORYQT function block

Signals

Table 306: SRMEMORYQT Input signals

Name	Type	Default	Description
SET	BOOLEAN	0	Input signal to set
RESET	BOOLEAN	0	Input signal to reset

Table 307: SRMEMORYQT Output signals

Name	Type	Description
OUT	BOOLEAN	Output signal
NOUT	BOOLEAN	Inverted output signal

Settings

Table 308: SRMEMORYQT Group settings (basic)

Name	Values (Range)	Unit	Step	Default	Description
Memory	Off On	-	-	On	Operating mode of the memory function

11.3.2.9 Reset-set function block RSMEMORYQT

Identification

Function description	IEC 61850 identification	IEC 60617 identification	ANSI/IEEE C37.2 device number
Reset/set logic component	RSMEMORYQT	-	-

Functionality

The Reset-set function (RSMEMORYQT) is a flip-flop with memory that can reset or set an output from two inputs respectively. Each RSMEMORYQT function block has two outputs, where one is inverted. The memory setting controls if the flip-flop after a power interruption will return the state it had before or if it will be reset. In RSMEMORYQT, the RESET input has priority over the SET input..

Table 309: Truth table for RSMEMORYQT function block

SET	RESET	OUT	NOUT
0	0	Last value	Inverted last value
0	1	0	1
1	0	1	0
1	1	0	1

RSMEMORYQT propagates quality and time as well as value.

Function block

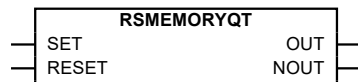

IEC09000302-1-en.vsd

Figure 186: RSMEMORYQT function block

Signals

Table 310: RSMEMORYQT Input signals

Name	Type	Default	Description
SET	BOOLEAN	0	Input signal to set
RESET	BOOLEAN	0	Input signal to reset

Table 311: RSMEMORYQT Output signals

Name	Type	Description
OUT	BOOLEAN	Output signal
NOUT	BOOLEAN	Inverted output signal

Settings

Table 312: RSMEMORYQT Group settings (basic)

Name	Values (Range)	Unit	Step	Default	Description
Memory	Off On	-	-	On	Operating mode of the memory function

11.3.2.10 INVALIDQT function block

Identification

Function description	IEC 61850 identification	IEC 60617 identification	ANSI/IEEE C37.2 device number
INVALIDQT function block	INVALIDQT	-	-

Function block

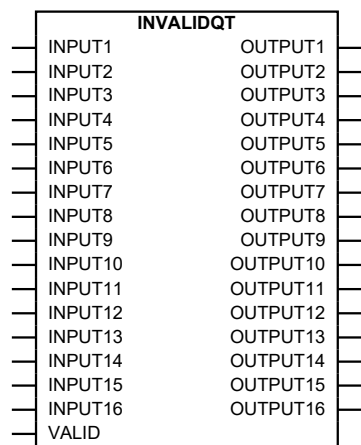

IEC09000305-1-en.vsd

Figure 187: INVALIDQT function block

Function which sets quality invalid of outputs according to a "valid" input.

Inputs are copied to outputs. If input VALID is 0, or if its quality invalid bit is set, all outputs invalid quality bit will be set. The timestamp of an output will be set to the latest timestamp of INPUT and VALID input.

Signals

Table 313: INVALIDQT Input signals

Name	Type	Default	Description
INPUT1	BOOLEAN	0	Indication input 1
INPUT2	BOOLEAN	0	Indication input 2
INPUT3	BOOLEAN	0	Indication input 3
INPUT4	BOOLEAN	0	Indication input 4
INPUT5	BOOLEAN	0	Indication input 5
INPUT6	BOOLEAN	0	Indication input 6
INPUT7	BOOLEAN	0	Indication input 7
INPUT8	BOOLEAN	0	Indication input 8
INPUT9	BOOLEAN	0	Indication input 9
INPUT10	BOOLEAN	0	Indication input 10
INPUT11	BOOLEAN	0	Indication input 11
INPUT12	BOOLEAN	0	Indication input 12
INPUT13	BOOLEAN	0	Indication input 13
INPUT14	BOOLEAN	0	Indication input 14
INPUT15	BOOLEAN	0	Indication input 15
INPUT16	BOOLEAN	0	Indication input 16
VALID	BOOLEAN	1	Inputs are valid or not

Table 314: INVALIDQT Output signals

Name	Type	Description
OUTPUT1	BOOLEAN	Indication output 1
OUTPUT2	BOOLEAN	Indication output 2
OUTPUT3	BOOLEAN	Indication output 3
OUTPUT4	BOOLEAN	Indication output 4
OUTPUT5	BOOLEAN	Indication output 5
OUTPUT6	BOOLEAN	Indication output 6
OUTPUT7	BOOLEAN	Indication output 7
OUTPUT8	BOOLEAN	Indication output 8
OUTPUT9	BOOLEAN	Indication output 9
OUTPUT10	BOOLEAN	Indication output 10
OUTPUT11	BOOLEAN	Indication output 11
OUTPUT12	BOOLEAN	Indication output 12
OUTPUT13	BOOLEAN	Indication output 13
OUTPUT14	BOOLEAN	Indication output 14
OUTPUT15	BOOLEAN	Indication output 15
OUTPUT16	BOOLEAN	Indication output 16

Settings

The function does not have any parameters available in Local HMI or Protection and Control IED Manager (PCM600).

11.3.2.11 Indication combining single position function block INDCOMBSPQT**Identification**

Function description	IEC 61850 identification	IEC 60617 identification	ANSI/IEEE C37.2 device number
Single indication signal combining function block	INDCOMBSPQT	-	-

Functionality

Single position input is copied to value part of SP_OUT output. TIME input is copied to time part of SP_OUT output. State input bits are copied to the corresponding state part of SP_OUT output. If the state or value on the SP_OUT output changes, the Event bit in the state part is toggled.

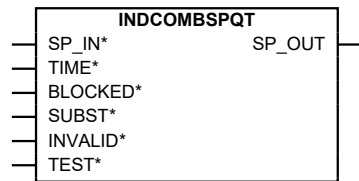
Function block

IEC09000306-1-en.vsd

Figure 188: INDCOMBSPQT function block

Signals

Table 315: INDCOMBSPQT Input signals

Name	Type	Default	Description
SP_IN	BOOLEAN	0	Single point indication
TIME	GROUP SIGNAL	0	Timestamp
BLOCKED	BOOLEAN	0	Blocked for update
SUBST	BOOLEAN	0	Substituted
INVALID	BOOLEAN	0	Invalid value
TEST	BOOLEAN	0	Testmode

Table 316: INDCOMBSPQT Output signals

Name	Type	Description
SP_OUT	BOOLEAN	Single point indication

Settings

The function does not have any parameters available in Local HMI or Protection and Control IED Manager (PCM600).

11.3.2.12 Indication extractor single position function block INDEXTSPQT

Identification

Function description	IEC 61850 identification	IEC 60617 identification	ANSI/IEEE C37.2 device number
Single indication signal extractor function block	INDEXTSPQT	-	-

Functionality

Value part of single position input is copied to SI_OUT output.

Time part of single position input is copied to TIME output.

State bits in common part and indication part of inputs signal is copied to the corresponding state output.

Function block

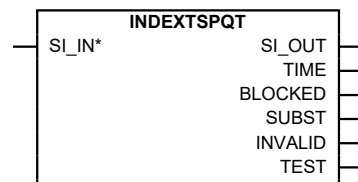

IEC09000307-1-en.vsd

Figure 189: INDEXTSPQT function block

Signals

Table 317: INDEXTSPQT Input signals

Name	Type	Default	Description
SI_IN	BOOLEAN	0	Single indication

Table 318: INDEXTSPQT Output signals

Name	Type	Description
SI_OUT	BOOLEAN	Single indication
TIME	GROUP SIGNAL	Timestamp of input
BLOCKED	BOOLEAN	Blocked for update
SUBST	BOOLEAN	Substituted
INVALID	BOOLEAN	Invalid value
TEST	BOOLEAN	Testmode

Settings

The function does not have any parameters available in Local HMI or Protection and Control IED Manager (PCM600).

11.3.3 Technical data

Table 319: Configurable logic blocks

Logic block	Quantity with cycle time			Range or value	Accuracy
	5 ms	20 ms	100 ms		
AND	60	60	160	-	-
OR	60	60	160	-	-
XOR	10	10	20	-	-
INVERTER	30	30	80	-	-
SRMEMORY	10	10	20	-	-
RSMEMORY	10	10	20	-	-
GATE	10	10	20	-	-
PULSETIMER	10	10	20	(0.000–90000.000) s	± 0.5% ± 25 ms for 20 ms cycle time
TIMERSET	10	10	20	(0.000–90000.000) s	± 0.5% ± 25 ms for 20 ms cycle time
LOOPDELAY	10	10	20		

Table 320: Configurable logic Q/T

Logic block	Quantity with cycle time		Range or value	Accuracy
	20 ms	100 ms		
ANDQT	20	100	-	-
ORQT	20	100	-	-
XORQT	10	30	-	-
INVERTERQT	20	100	-	-
RSMEMORYQT	10	30	-	-
SRMEMORYQT	15	10	-	-
PULSETIMERQT	10	30	(0.000–90000.000) s	± 0.5% ± 25 ms for 20 ms cycle time
TIMERSETQT	10	30	(0.000–90000.000) s	± 0.5% ± 25 ms for 20 ms cycle time
INVALIDQT	6	6	-	-
INDCOMBSPQT	10	10	-	-
INDEXTSPQT	10	10	-	-

11.4 Fixed signals FXDSIGN

11.4.1 Identification

Function description	IEC 61850 identification	IEC 60617 identification	ANSI/IEEE C37.2 device number
Fixed signals	FXDSIGN	-	-

11.4.2 Functionality

The Fixed signals function FXDSIGN generates nine pre-set (fixed) signals that can be used in the configuration of an IED, either for forcing the unused inputs in other function blocks to a certain level/value, or for creating certain logic. Boolean, integer, floating point, string types of signals are available.

11.4.3 Function block

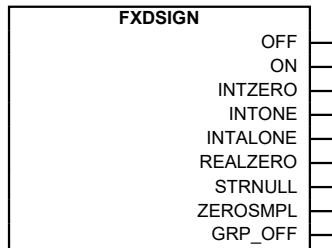

IEC09000037.vsd

Figure 190: FXDSIGN function block

11.4.4 Signals

Table 321: FXDSIGN Output signals

Name	Type	Description
OFF	BOOLEAN	Boolean signal fixed off
ON	BOOLEAN	Boolean signal fixed on
INTZERO	INTEGER	Integer signal fixed zero
INTONE	INTEGER	Integer signal fixed one
INTALONE	INTEGER	Integer signal fixed all ones
REALZERO	REAL	Real signal fixed zero
STRNULL	STRING	String signal with no characters
ZEROSMPL	GROUP SIGNAL	Channel id for zero sample
GRP_OFF	GROUP SIGNAL	Group signal fixed off

11.4.5 Settings

The function does not have any settings available in Local HMI or Protection and Control IED Manager (PCM600).

11.4.6 Operation principle

There are nine outputs from FXDSIGN function block:

- OFF is a boolean signal, fixed to OFF (boolean 0) value
- ON is a boolean signal, fixed to ON (boolean 1) value
- INTZERO is an integer number, fixed to integer value 0
- INTONE is an integer number, fixed to integer value 1

- INTALONE is an integer value FFFF (hex)
- REALZERO is a floating point real number, fixed to 0.0 value
- STRNULL is a string, fixed to an empty string (null) value
- ZEROSMPL is a channel index, fixed to 0 value
- GRP_OFF is a group signal, fixed to 0 value

11.5 Boolean 16 to integer conversion B16I

11.5.1 Identification

Function description	IEC 61850 identification	IEC 60617 identification	ANSI/IEEE C37.2 device number
Boolean 16 to integer conversion	B16I	-	-

11.5.2 Functionality

Boolean 16 to integer conversion function B16I is used to transform a set of 16 binary (logical) signals into an integer.

11.5.3 Function block

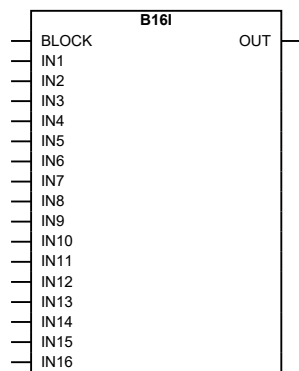

IEC09000035-1-en.vsd

Figure 191: B16I function block

11.5.4 Signals

Table 322: B16I Input signals

Name	Type	Default	Description
BLOCK	BOOLEAN	0	Block of function
IN1	BOOLEAN	0	Input 1
IN2	BOOLEAN	0	Input 2
IN3	BOOLEAN	0	Input 3
IN4	BOOLEAN	0	Input 4
IN5	BOOLEAN	0	Input 5

Table continues on next page

Name	Type	Default	Description
IN6	BOOLEAN	0	Input 6
IN7	BOOLEAN	0	Input 7
IN8	BOOLEAN	0	Input 8
IN9	BOOLEAN	0	Input 9
IN10	BOOLEAN	0	Input 10
IN11	BOOLEAN	0	Input 11
IN12	BOOLEAN	0	Input 12
IN13	BOOLEAN	0	Input 13
IN14	BOOLEAN	0	Input 14
IN15	BOOLEAN	0	Input 15
IN16	BOOLEAN	0	Input 16

Table 323: B16I Output signals

Name	Type	Description
OUT	INTEGER	Output value

11.5.5 Settings

The function does not have any parameters available in local HMI or Protection and Control IED Manager (PCM600)

11.5.6 Monitored data

Table 324: B16I Monitored data

Name	Type	Values (Range)	Unit	Description
OUT	INTEGER	-	-	Output value

11.5.7 Operation principle

The Boolean 16 to integer conversion function (B16I) will transfer a combination of up to 16 binary inputs INx, where 1 ≤ x ≤ 16, to an integer. Each INx represents a value according to the table below from 0 to 32768. This follows the general formula: $IN_x = 2^{x-1}$ where 1 ≤ x ≤ 16. The sum of all the values on the activated INx will be available on the output OUT as a sum of the integer values of all the inputs INx that are activated. OUT is an integer. When all INx (where 1 ≤ x ≤ 16) are activated, that is = Boolean 1, it corresponds to that integer 65535 is available on the output OUT. The B16I function is designed for receiving up to 16 booleans input locally. If the BLOCK input is activated, it will freeze the output at the last value.

Values of each of the different OUTx from function block B16I for 1 ≤ x ≤ 16.

The sum of the value on each INx corresponds to the integer presented on the output OUT on the function block B16I

Name of input	Type	Default	Description	Value when activated	Value when deactivated
IN1	BOOLEAN	0	Input 1	1	0
IN2	BOOLEAN	0	Input 2	2	0
IN3	BOOLEAN	0	Input 3	4	0
IN4	BOOLEAN	0	Input 4	8	0
IN5	BOOLEAN	0	Input 5	16	0
IN6	BOOLEAN	0	Input 6	32	0
IN7	BOOLEAN	0	Input 7	64	0
IN8	BOOLEAN	0	Input 8	128	0
IN9	BOOLEAN	0	Input 9	256	0
IN10	BOOLEAN	0	Input 10	512	0
IN11	BOOLEAN	0	Input 11	1024	0
IN12	BOOLEAN	0	Input 12	2048	0
IN13	BOOLEAN	0	Input 13	4096	0
IN14	BOOLEAN	0	Input 14	8192	0
IN15	BOOLEAN	0	Input 15	16384	0
IN16	BOOLEAN	0	Input 16	32768	0

The sum of the numbers in column “Value when activated” when all IN_x (where 1≤x≤16) are active that is=1; is 65535. 65535 is the highest boolean value that can be converted to an integer by the B16I function block.

11.6 Boolean 16 to integer conversion with logic node representation B16IFCVI

11.6.1 Identification

Function description	IEC 61850 identification	IEC 60617 identification	ANSI/IEEE C37.2 device number
Boolean 16 to integer conversion with logic node representation	B16IFCVI	-	-

11.6.2 Functionality

Boolean 16 to integer conversion with logic node representation function B16IFCVI is used to transform a set of 16 binary (logical) signals into an integer. The block input will freeze the output at the last value.

11.6.3 Function block

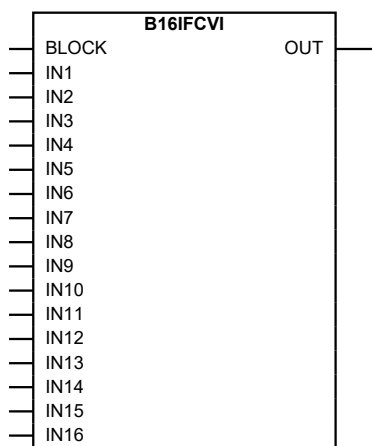

IEC09000624-1-en.vsd

Figure 192: B16IFCVI function block

11.6.4 Signals

Table 325: B16IFCVI Input signals

Name	Type	Default	Description
BLOCK	BOOLEAN	0	Block of function
IN1	BOOLEAN	0	Input 1
IN2	BOOLEAN	0	Input 2
IN3	BOOLEAN	0	Input 3
IN4	BOOLEAN	0	Input 4
IN5	BOOLEAN	0	Input 5
IN6	BOOLEAN	0	Input 6
IN7	BOOLEAN	0	Input 7
IN8	BOOLEAN	0	Input 8
IN9	BOOLEAN	0	Input 9
IN10	BOOLEAN	0	Input 10
IN11	BOOLEAN	0	Input 11
IN12	BOOLEAN	0	Input 12
IN13	BOOLEAN	0	Input 13
IN14	BOOLEAN	0	Input 14
IN15	BOOLEAN	0	Input 15
IN16	BOOLEAN	0	Input 16

Table 326: B16IFCVI Output signals

Name	Type	Description
OUT	INTEGER	Output value

11.6.5 Settings

The function does not have any parameters available in local HMI or Protection and Control IED Manager (PCM600)

11.6.6 Monitored data

Table 327: B16IFCVI Monitored data

Name	Type	Values (Range)	Unit	Description
OUT	INTEGER	-	-	Output value

11.6.7 Operation principle

The Boolean 16 to integer conversion with logic node representation function (B16IFCVI) will transfer a combination of up to 16 binary inputs IN_x, where 1 ≤ x ≤ 16, to an integer. Each IN_x represents a value according to the table below from 0 to 32768. This follows the general formula: $IN_x = 2^{x-1}$ where 1 ≤ x ≤ 16. The sum of all the values on the activated IN_x will be available on the output OUT as a sum of the integer values of all the inputs IN_x that are activated. OUT is an integer. When all IN_x (where 1 ≤ x ≤ 16) are activated, that is = Boolean 1, it corresponds to that integer 65535 is available on the output OUT. The B16IFCVI function is designed for receiving the integer input from a station computer - for example, over IEC 61850. If the BLOCK input is activated, it will freeze the logical outputs at the last value.

Values of each of the different OUT_x from function block B16IFCVI for 1 ≤ x ≤ 16.

The sum of the value on each IN_x corresponds to the integer presented on the output OUT on the function block B16IFCVI.

Name of input	Type	Default	Description	Value when activated	Value when deactivated
IN1	BOOLEAN	0	Input 1	1	0
IN2	BOOLEAN	0	Input 2	2	0
IN3	BOOLEAN	0	Input 3	4	0
IN4	BOOLEAN	0	Input 4	8	0
IN5	BOOLEAN	0	Input 5	16	0
IN6	BOOLEAN	0	Input 6	32	0
IN7	BOOLEAN	0	Input 7	64	0
IN8	BOOLEAN	0	Input 8	128	0
IN9	BOOLEAN	0	Input 9	256	0
IN10	BOOLEAN	0	Input 10	512	0
IN11	BOOLEAN	0	Input 11	1024	0
IN12	BOOLEAN	0	Input 12	2048	0
IN13	BOOLEAN	0	Input 13	4096	0
IN14	BOOLEAN	0	Input 14	8192	0
IN15	BOOLEAN	0	Input 15	16384	0
IN16	BOOLEAN	0	Input 16	32768	0

The sum of the numbers in column “Value when activated” when all INx (where 1≤x≤16) are active that is=1; is 65535. 65535 is the highest boolean value that can be converted to an integer by the B16IFCVI function block.

11.7 Integer to boolean 16 conversion IB16A

11.7.1 Identification

Function description	IEC 61850 identification	IEC 60617 identification	ANSI/IEEE C37.2 device number
Integer to boolean 16 conversion	IB16A	-	-

11.7.2 Functionality

Integer to boolean 16 conversion function IB16A is used to transform an integer into a set of 16 binary (logical) signals.

11.7.3 Function block

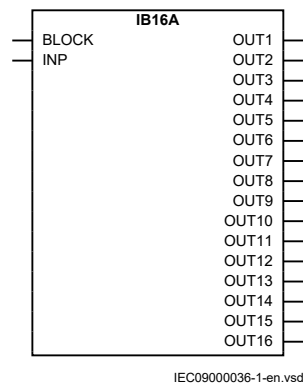

Figure 193: IB16A function block

11.7.4 Signals

Table 328: IB16A Input signals

Name	Type	Default	Description
BLOCK	BOOLEAN	0	Block of function
INP	INTEGER	0	Integer Input

Table 329: IB16A Output signals

Name	Type	Description
OUT1	BOOLEAN	Output 1
OUT2	BOOLEAN	Output 2
OUT3	BOOLEAN	Output 3
OUT4	BOOLEAN	Output 4
OUT5	BOOLEAN	Output 5
OUT6	BOOLEAN	Output 6
OUT7	BOOLEAN	Output 7
OUT8	BOOLEAN	Output 8
OUT9	BOOLEAN	Output 9
OUT10	BOOLEAN	Output 10
OUT11	BOOLEAN	Output 11
OUT12	BOOLEAN	Output 12
OUT13	BOOLEAN	Output 13
OUT14	BOOLEAN	Output 14
OUT15	BOOLEAN	Output 15
OUT16	BOOLEAN	Output 16

11.7.5 Settings

The function does not have any parameters available in local HMI or Protection and Control IED Manager (PCM600)

11.7.6 Operation principle

With integer 15 on the input INP the $OUT1 = OUT2 = OUT3 = OUT4 = 1$ and the remaining $OUTx = 0$ for $(5 \leq x \leq 16)$.

$OUTx$ represents a value when activated. The value of each of the $OUTx$ is in accordance with the table IB16A_1. When not activated the $OUTx$ has the value 0.

In the above example when integer 15 is on the input INP the $OUT1$ has a value =1, $OUT2$ has a value =2, $OUT3$ has a value =4 and $OUT4$ has a value =8. The sum of these $OUTx$ is equal to $1 + 2 + 4 + 8 = 15$.

This follows the general formulae: The sum of the values of all $OUTx = 2^{x-1}$ where $1 \leq x \leq 16$ will be equal to the integer value on the input INP.

The Integer to Boolean 16 conversion function (IB16A) will transfer an integer with a value between 0 to 65535 connected to the input INP to a combination of activated outputs $OUTx$ where $1 \leq x \leq 16$. The sum of the values of all $OUTx$ will then be equal to the integer on input INP. The values of the different $OUTx$ are according to the table below. When an $OUTx$ is not activated, its value is 0.

When all $OUTx$ where $1 \leq x \leq 16$ are activated that is = Boolean 1 it corresponds to that integer 65535 is connected to input INP. The IB16A function is designed for receiving the integer input locally. If the BLOCK input is activated, it will freeze the logical outputs at the last value.

Values of each of the different $OUTx$ from function block IB16A for $1 \leq x \leq 16$.

The sum of the value on each INx corresponds to the integer presented on the output OUT on the function block IB16A.

Name of OUTx	Type	Description	Value when activated	Value when deactivated
OUT1	BOOLEAN	Output 1	1	0
OUT2	BOOLEAN	Output 2	2	0
OUT3	BOOLEAN	Output 3	4	0
OUT4	BOOLEAN	Output 4	8	0
OUT5	BOOLEAN	Output 5	16	0
OUT6	BOOLEAN	Output 6	32	0
OUT7	BOOLEAN	Output 7	64	0
OUT8	BOOLEAN	Output 8	128	0
OUT9	BOOLEAN	Output 9	256	0
OUT10	BOOLEAN	Output 10	512	0
OUT11	BOOLEAN	Output 11	1024	0
OUT12	BOOLEAN	Output 12	2048	0
OUT13	BOOLEAN	Output 13	4096	0
OUT14	BOOLEAN	Output 14	8192	0
OUT15	BOOLEAN	Output 15	16384	0
OUT16	BOOLEAN	Output 16	32768	0

The sum of the numbers in column “Value when activated” when all OUTx (where x = 1 to 16) are active that is=1; is 65535. 65535 is the highest integer that can be converted by the IB16A function block.

11.8 Integer to boolean 16 conversion with logic node representation IB16FCVB

11.8.1 Identification

Function description	IEC 61850 identification	IEC 60617 identification	ANSI/IEEE C37.2 device number
Integer to boolean 16 conversion with logic node representation	IB16FCVB	-	-

11.8.2 Functionality

Integer to boolean conversion with logic node representation function IB16FCVB is used to transform an integer to 16 binary (logic) signals.

IB16FCVB function can receive remote values over IEC61850 when the operator position input PSTO is in position remote. The block input will freeze the output at the last value.

11.8.3 Function block

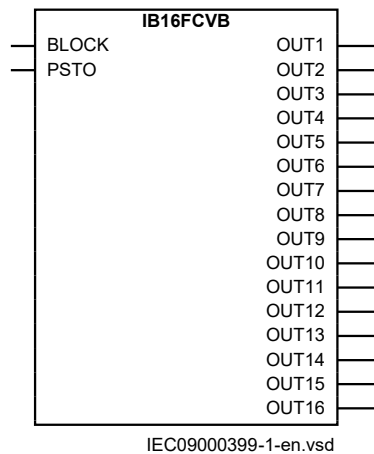

Figure 194: IB16FCVB function block

11.8.4 Signals

Table 330: IB16FCVB Input signals

Name	Type	Default	Description
BLOCK	BOOLEAN	0	Block of function
PSTO	INTEGER	1	Operator place selection

Table 331: IB16FCVB Output signals

Name	Type	Description
OUT1	BOOLEAN	Output 1
OUT2	BOOLEAN	Output 2
OUT3	BOOLEAN	Output 3
OUT4	BOOLEAN	Output 4
OUT5	BOOLEAN	Output 5
OUT6	BOOLEAN	Output 6
OUT7	BOOLEAN	Output 7
OUT8	BOOLEAN	Output 8
OUT9	BOOLEAN	Output 9
OUT10	BOOLEAN	Output 10
OUT11	BOOLEAN	Output 11
OUT12	BOOLEAN	Output 12
OUT13	BOOLEAN	Output 13
OUT14	BOOLEAN	Output 14
OUT15	BOOLEAN	Output 15
OUT16	BOOLEAN	Output 16

11.8.5 Settings

The function does not have any parameters available in local HMI or Protection and Control IED Manager (PCM600)

11.8.6 Operation principle

An example is used to explain the principle of operation: With integer 15 sent to and received by the IB16FCVB function on the IEC 61850 the OUTx changes from 0 to 1 on each of the OUT1; OUT2 OUT3 and OUT4. All other OUTx (5≤x≤16) remains 0. The boolean interpretation of this is represented by the assigned values of each of the outputs OUT1 = 1; and OUT2 = 2; and OUT3 = 4; and OUT4 = 8. The sum of these OUTx (1≤x≤4) is equal to the integer 15 received via the IEC 61850 network. The remaining OUTx = 0 for (5≤x≤16).

OUTx represents a value when activated. The value of each of the OUTx is in accordance with the Table 332. When not activated the OUTx has the value 0.

The value of each OUTx for 1≤x≤16 (1≤x≤16) follows the general formulae: $OUT_x = 2^{x-1}$ The sum of the values of all activated $OUT_x = 2^{x-1}$ where 1≤x≤16 will be equal to the integer value received over IEC 61850 to the IB16FCVB_1 function block.

The Integer to Boolean 16 conversion with logic node representation function (IB16FCVB) will transfer an integer with a value between 0 to 65535 communicated via IEC 61850 and connected to the IB16FCVB function block to a combination of activated outputs OUTx where 1≤x≤16. The values represented by the different OUTx are according to Table 332. When an OUTx is not activated, its value is 0.

The IB16FCVB function is designed for receiving the integer input from a station computer - for example, over IEC 61850. If the BLOCK input is activated, it will freeze the logical outputs at the last value.

Table 332: Outputs and their values when activated

Name of OUTx	Type	Description	Value when activated	Value when deactivated
OUT1	BOOLEAN	Output 1	1	0
OUT2	BOOLEAN	Output 2	2	0
OUT3	BOOLEAN	Output 3	4	0
OUT4	BOOLEAN	Output 4	8	0
OUT5	BOOLEAN	Output 5	16	0
OUT6	BOOLEAN	Output 6	32	0
OUT7	BOOLEAN	Output 7	64	0
OUT8	BOOLEAN	Output 8	128	0
OUT9	BOOLEAN	Output 9	256	0
OUT10	BOOLEAN	Output 10	512	0
OUT11	BOOLEAN	Output 11	1024	0
OUT12	BOOLEAN	Output 12	2048	0
OUT13	BOOLEAN	Output 13	4096	0
OUT14	BOOLEAN	Output 14	8192	0
OUT15	BOOLEAN	Output 15	16384	0
OUT16	BOOLEAN	Output 16	32768	0

The sum of the numbers in column "Value when activated" when all OUTx (1≤x≤16) are active equals 65535. This is the highest integer that can be converted to boolean by the IB16FCVB function block.

The operator position input (PSTO) determines the operator place. The integer number that is communicated to the IB16FCVB can only be written to the block while the PSTO is in position "Remote". If PSTO is in position "Off" or "Local", then no changes are applied to the outputs.

11.9 Elapsed time integrator with limit transgression and overflow supervision TEIGGIO

11.9.1 Identification

Function Description	IEC 61850 identification	IEC 60617 identification	ANSI/IEEE C37.2 device number
Elapsed time integrator	TEIGGIO	-	-

11.9.2 Functionality

Elapsed Time Integrator (TEIGGIO) function is a function that accumulates the elapsed time when a given binary signal has been high.

The main features of TEIGGIO are

- Applicable to long time integration (≤999 999.9 seconds).
- Supervision of limit transgression conditions and overflow.
- Possibility defining a warning or alarm with the resolution of 10 milliseconds.
- Retain the integration value at a warning/alarm/overflow.
- Possibilities for blocking and reset.
- Report the integrated time

11.9.3 Function block

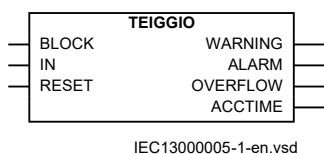

Figure 195: TEIGGIO function block

11.9.4 Signals

Table 333: TEIGGIO Input signals

Name	Type	Default	Description
BLOCK	BOOLEAN	0	Freeze the integration and block the other outputs
IN	BOOLEAN	0	The input signal that is used to measure the elapsed time, when its value is high
RESET	BOOLEAN	0	Reset the integration time

Table 334: TEIGGIO Output signals

Name	Type	Description
WARNING	BOOLEAN	Indicator of the integrated time has reached the warning limit
ALARM	BOOLEAN	Indicator of the integrated time has reached the alarm limit
OVERFLOW	BOOLEAN	Indicator of the integrated time has reached the overflow limit
ACCTIME	REAL	Integrated elapsed time in seconds

11.9.5 Settings

Table 335: TEIGGIO Group settings (basic)

Name	Values (Range)	Unit	Step	Default	Description
Operation	0 - 1	-	1	1	Operation Off / On
tWarning	1.00 - 999999.99	s	0.01	600.00	Time limit for warning supervision
tAlarm	1.00 - 999999.99	s	0.01	1200.00	Time limit for alarm supervision

11.9.6 Operation principle

The elapsed time integrator (TEIGGIO) provides

- time integration, accumulating the elapsed time when a given binary signal has been high.
- blocking and reset.
- supervision of limit transgression and overflow.
- retaining of the integrated value if any warning, alarm or overflow occurs.

Figure 196 describes the simplified logic of the function where the block “Time Integration” covers the logics for the first two items listed above while the block “Transgression Supervision Plus Retain” contains the logics for the last two.

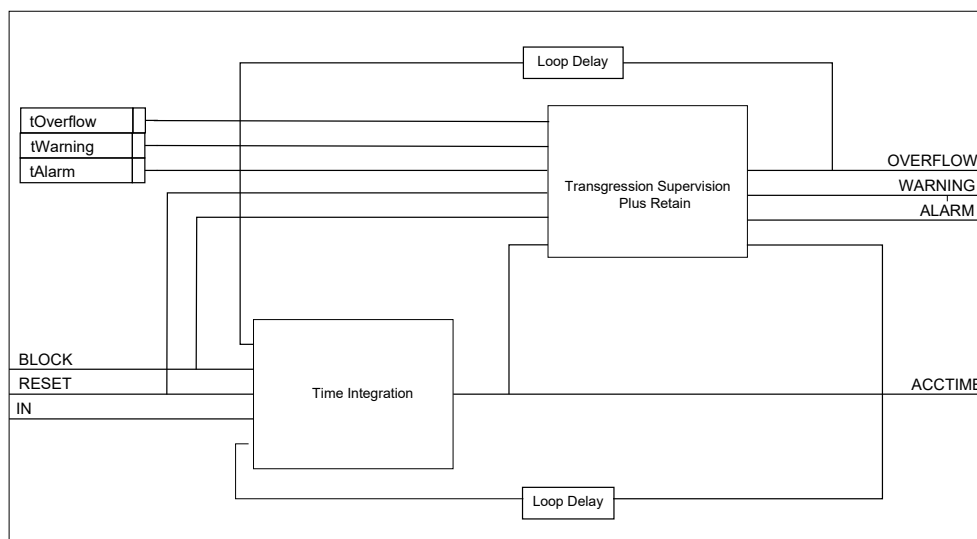

Figure 196: TEIGGIO Simplified logic

IEC12000195-2-en.vsd

TEIGGIO main functionalities are

- integrate the elapsed time when IN has been high
 - applicable to long time integration ($\leq 999\ 999.9$ seconds)
 - output ACCTIME presents integrated value in seconds to all tools
 - integrated value is retained in non-volatile memory, if any warning, alarm or overflow occurs
 - any retained value with a warning/alarm/overflow shall be available as the initiation value for the integration followed by a restart.
- RESET: Reset the integration value. Consequently all other outputs are also reset
 - unconditionally on the input IN value
 - reset the value of the non-volatile memory to zero.
- BLOCK: Freeze the integration and block/reset the other outputs
 - unconditionally on the signal value
 - BLOCK request overrides RESET request.
- Monitor and report the conditions of limit transgression
 - overflow if output ACCTIME > $t_{Overflow}$
 - alarm if ACCTIME > t_{Alarm}
 - warning if ACCTIME > $t_{Warning}$.

The ACCTIME output represents the integrated time in seconds while $t_{Overflow}$, t_{Alarm} and $t_{Warning}$ are the time limit parameters in seconds.

t_{Alarm} and $t_{Warning}$ are user settable limits. They are also independent, that is, there is no check if $t_{Alarm} > t_{Warning}$.

t_{Alarm} and $t_{Warning}$ are possible to be defined with a resolution of 10 ms, depending on the level of the defined values for the parameters.

$t_{Overflow}$ is for the overflow supervision with a default value $t_{Overflow} = 999\ 999.9$ seconds. The outputs freeze if an overflow occurs.

11.9.6.1 Operation Accuracy

The accuracy of TEIGGIO depends on essentially three factors

- task cycle time
- the pulse length
- the number of pulses, that is the number of rising and falling flank pairs

In principle, a shorter task cycle time, longer integrated time length or more pulses may lead to reduced accuracy.

11.9.6.2 Memory storage

The value of the integrated elapsed time is retained in a non-volatile memory, only if any warning, alarm or/and overflow occurs. Consequently there is a risk of data loss in the integrated time at a power failure.

11.9.7 Technical data

Table 336: TEIGGIO Technical data

Function	Cycle time (ms)	Range or value	Accuracy
Elapsed time integration	5	0 ~ 999999.9 s	±0.05% or ±0.015 s
	20	0 ~ 999999.9 s	±0.05% or ±0.04 s
	100	0 ~ 999999.9 s	±0.05% or ±0.2 s

Section 12 Monitoring

12.1 Measurements

12.1.1 Functionality

Measurement functions is used for power system measurement, supervision and reporting to the local HMI, monitoring tool within PCM600 or to station level for example, via IEC 61850. The possibility to continuously monitor measured values of active power, reactive power, currents, voltages, frequency, power factor etc. is vital for efficient production, transmission and distribution of electrical energy. It provides to the system operator fast and easy overview of the present status of the power system. Additionally, it can be used during testing and commissioning of protection and control IEDs in order to verify proper operation and connection of instrument transformers (CTs and VTs). During normal service by periodic comparison of the measured value from the IED with other independent meters the proper operation of the IED analog measurement chain can be verified. Finally, it can be used to verify proper direction orientation for distance or directional overcurrent protection function.



The available measured values of an IED are depending on the actual hardware (TRM) and the logic configuration made in PCM600.

All measured values can be supervised with four settable limits that is, low-low limit, low limit, high limit and high-high limit. A zero clamping reduction is also supported, that is, the measured value below a settable limit is forced to zero which reduces the impact of noise in the inputs. There are no interconnections regarding any settings or parameters, neither between functions nor between signals within each function.

Zero clampings are handled by *ZeroDb* for each signal separately for each of the functions. For example, the zero clamping of U12 is handled by *ULZeroDb* in VMMXU, zero clamping of I1 is handled by *ILZeroDb* in CMMXU.

Dead-band supervision can be used to report measured signal value to station level when change in measured value is above set threshold limit or time integral of all changes since the last time value updating exceeds the threshold limit. Measure value can also be based on periodic reporting.

The measurement function, CVMMXN, provides the following power system quantities:

- P, Q and S: three phase active, reactive and apparent power
- PF: power factor
- U: phase-to-phase voltage amplitude
- I: phase current amplitude
- F: power system frequency

The output values are displayed in the local HMI under **Main menu/Tests/Function status/Monitoring/CVMMXN/Outputs**

The measuring functions CMMXU, VNMMXU and VMMXU provide physical quantities:

- I: phase currents (amplitude and angle) (CMMXU)
- U: voltages (phase-to-earth and phase-to-phase voltage, amplitude and angle) (VMMXU, VNMMXU)

It is possible to calibrate the measuring function above to get better than class 0.5 presentation. This is accomplished by angle and amplitude compensation at 5, 30 and 100% of rated current and at 100% of rated voltage.



The power system quantities provided, depends on the actual hardware, (TRM) and the logic configuration made in PCM600.

The measuring functions CMSQI and VMSQI provide sequence component quantities:

- I: sequence currents (positive, zero, negative sequence, amplitude and angle)
- U: sequence voltages (positive, zero and negative sequence, amplitude and angle).

The CVMMXN function calculates three-phase power quantities by using fundamental frequency phasors (DFT values) of the measured current respectively voltage signals. The measured power quantities are available either, as instantaneously calculated quantities or, averaged values over a period of time (low pass filtered) depending on the selected settings.

12.1.2 Measurements CVMMXN

12.1.2.1 Identification

Function description	IEC 61850 identification	IEC 60617 identification	ANSI/IEEE C37.2 device number
Measurements	CVMMXN	<div style="border: 1px solid black; padding: 5px; width: fit-content; margin: 0 auto;"> <i>P, Q, S, I, U, f</i> </div>	-

12.1.2.2 Function block

The available function blocks of an IED are depending on the actual hardware (TRM) and the logic configuration made in PCM600.

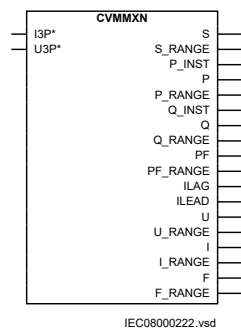

Figure 197: CVMMXN function block

12.1.2.3 Signals

Table 337: CVMMXN Input signals

Name	Type	Default	Description
I3P	GROUP SIGNAL	-	Three phase group signal for current inputs
U3P	GROUP SIGNAL	-	Three phase group signal for voltage inputs

Table 338: CVMMXN Output signals

Name	Type	Description
S	REAL	Apparent power magnitude of deadband value
S_RANGE	INTEGER	Apparent power range
P_INST	REAL	Active power
P	REAL	Active power magnitude of deadband value
P_RANGE	INTEGER	Active power range
Q_INST	REAL	Reactive power
Q	REAL	Reactive power magnitude of deadband value
Q_RANGE	INTEGER	Reactive power range
PF	REAL	Power factor magnitude of deadband value
PF_RANGE	INTEGER	Power factor range
ILAG	BOOLEAN	Current is lagging voltage
ILEAD	BOOLEAN	Current is leading voltage
U	REAL	Calculated voltage magnitude of deadband value
U_RANGE	INTEGER	Calculated voltage range
I	REAL	Calculated current magnitude of deadband value
I_RANGE	INTEGER	Calculated current range
F	REAL	System frequency magnitude of deadband value
F_RANGE	INTEGER	System frequency range

12.1.2.4 Settings

Table 339: CVMMXN Non group settings (basic)

Name	Values (Range)	Unit	Step	Default	Description
Operation	Off On	-	-	Off	Operation Off / On
GlobalBaseSel	1 - 6	-	1	1	Selection of one of the Global Base Value groups
Mode	L1, L2, L3 Arone Pos Seq L1L2 L2L3 L3L1 L1 L2 L3	-	-	L1, L2, L3	Selection of measured current and voltage
PowAmpFact	0.000 - 6.000	-	0.001	1.000	Amplitude factor to scale power calculations
PowAngComp	-180.0 - 180.0	Deg	0.1	0.0	Angle compensation for phase shift between measured I & U
k	0.00 - 1.00	-	0.01	0.00	Low pass filter coefficient for power measurement
SLowLim	0.0 - 2000.0	%SB	0.1	80.0	Low limit in % of SBase
SLowLowLim	0.0 - 2000.0	%SB	0.1	60.0	Low Low limit in % of SBase
SMin	0.0 - 2000.0	%SB	0.1	50.0	Minimum value in % of SBase
SMax	0.0 - 2000.0	%SB	0.1	200.0	Maximum value in % of SBase
SRepTyp	Cyclic Dead band Int deadband	-	-	Cyclic	Reporting type
PMin	-2000.0 - 2000.0	%SB	0.1	-200.0	Minimum value in % of SBase
PMax	-2000.0 - 2000.0	%SB	0.1	200.0	Maximum value in % of SBase
PRepTyp	Cyclic Dead band Int deadband	-	-	Cyclic	Reporting type
QMin	-2000.0 - 2000.0	%SB	0.1	-200.0	Minimum value in % of SBase
QMax	-2000.0 - 2000.0	%SB	0.1	200.0	Maximum value in % of SBase
QRepTyp	Cyclic Dead band Int deadband	-	-	Cyclic	Reporting type
PFMin	-1.000 - 1.000	-	0.001	-1.000	Minimum value
PFMax	-1.000 - 1.000	-	0.001	1.000	Maximum value
PFRepTyp	Cyclic Dead band Int deadband	-	-	Cyclic	Reporting type
UMin	0.0 - 200.0	%UB	0.1	50.0	Minimum value in % of UBase
UMax	0.0 - 200.0	%UB	0.1	200.0	Maximum value in % of UBase
URepTyp	Cyclic Dead band Int deadband	-	-	Cyclic	Reporting type
IMin	0.0 - 500.0	%IB	0.1	50.0	Minimum value in % of IBase
IMax	0.0 - 500.0	%IB	0.1	200.0	Maximum value in % of IBase

Table continues on next page

Name	Values (Range)	Unit	Step	Default	Description
IRepTyp	Cyclic Dead band Int deadband	-	-	Cyclic	Reporting type
FrMin	0.000 - 100.000	Hz	0.001	0.000	Minimum value
FrMax	0.000 - 100.000	Hz	0.001	70.000	Maximum value
FrRepTyp	Cyclic Dead band Int deadband	-	-	Cyclic	Reporting type

Table 340: CVMMXN Non group settings (advanced)

Name	Values (Range)	Unit	Step	Default	Description
SDBReplnt	1 - 300	Type	1	10	Cycl: Report interval (s), Db: In % of range, Int Db: In %s
SZeroDb	0 - 100000	m%	1	500	Zero point clamping in 0,001% of range
SHiHiLim	0.0 - 2000.0	%SB	0.1	150.0	High High limit in % of SBase
SHiLim	0.0 - 2000.0	%SB	0.1	120.0	High limit in % of SBase
PHiHiLim	-2000.0 - 2000.0	%SB	0.1	150.0	High High limit in % of SBase
SLimHyst	0.000 - 100.000	%	0.001	5.000	Hysteresis value in % of range (common for all limits)
PDBReplnt	1 - 300	Type	1	10	Cycl: Report interval (s), Db: In % of range, Int Db: In %s
PZeroDb	0 - 100000	m%	1	500	Zero point clamping
PHiLim	-2000.0 - 2000.0	%SB	0.1	120.0	High limit in % of SBase
PLowLim	-2000.0 - 2000.0	%SB	0.1	-120.0	Low limit in % of SBase
PLowLowLim	-2000.0 - 2000.0	%SB	0.1	-150.0	Low Low limit in % of SBase
PLimHyst	0.000 - 100.000	%	0.001	5.000	Hysteresis value in % of range (common for all limits)
QDBReplnt	1 - 300	Type	1	10	Cycl: Report interval (s), Db: In % of range, Int Db: In %s
QZeroDb	0 - 100000	m%	1	500	Zero point clamping
QHiHiLim	-2000.0 - 2000.0	%SB	0.1	150.0	High High limit in % of SBase
QHiLim	-2000.0 - 2000.0	%SB	0.1	120.0	High limit in % of SBase
QLowLim	-2000.0 - 2000.0	%SB	0.1	-120.0	Low limit in % of SBase
QLowLowLim	-2000.0 - 2000.0	%SB	0.1	-150.0	Low Low limit in % of SBase
QLimHyst	0.000 - 100.000	%	0.001	5.000	Hysteresis value in % of range (common for all limits)
UGenZeroDb	1 - 100	%UB	1	5	Zero point clamping in % of Ubase
PFDReplnt	1 - 300	Type	1	10	Cycl: Report interval (s), Db: In % of range, Int Db: In %s
PFZeroDb	0 - 100000	m%	1	500	Zero point clamping
IGenZeroDb	1 - 100	%IB	1	5	Zero point clamping in % of Ibase
PFHiHiLim	-1.000 - 1.000	-	0.001	1.000	High High limit (physical value)
PFHiLim	-1.000 - 1.000	-	0.001	0.800	High limit (physical value)
PFLowLim	-1.000 - 1.000	-	0.001	-0.800	Low limit (physical value)
PFLowLowLim	-1.000 - 1.000	-	0.001	-1.000	Low Low limit (physical value)

Table continues on next page

Name	Values (Range)	Unit	Step	Default	Description
PFLimHyst	0.000 - 100.000	%	0.001	5.000	Hysteresis value in % of range (common for all limits)
UDbReplnt	1 - 300	Type	1	10	Cycl: Report interval (s), Db: In % of range, Int Db: In %s
UZeroDb	0 - 100000	m%	1	500	Zero point clamping
UHiHiLim	0.0 - 200.0	%UB	0.1	150.0	High High limit in % of UBase
UHiLim	0.0 - 200.0	%UB	0.1	120.0	High limit in % of UBase
ULowLim	0.0 - 200.0	%UB	0.1	80.0	Low limit in % of UBase
ULowLowLim	0.0 - 200.0	%UB	0.1	60.0	Low Low limit in % of UBase
ULimHyst	0.000 - 100.000	%	0.001	5.000	Hysteresis value in % of range (common for all limits)
IDbReplnt	1 - 300	Type	1	10	Cycl: Report interval (s), Db: In % of range, Int Db: In %s
IZeroDb	0 - 100000	m%	1	500	Zero point clamping
IHiHiLim	0.0 - 500.0	%IB	0.1	150.0	High High limit in % of IBase
IHiLim	0.0 - 500.0	%IB	0.1	120.0	High limit in % of IBase
ILowLim	0.0 - 500.0	%IB	0.1	80.0	Low limit in % of IBase
ILowLowLim	0.0 - 500.0	%IB	0.1	60.0	Low Low limit in % of IBase
ILimHyst	0.000 - 100.000	%	0.001	5.000	Hysteresis value in % of range (common for all limits)
FrDbReplnt	1 - 300	Type	1	10	Cycl: Report interval (s), Db: In % of range, Int Db: In %s
FrZeroDb	0 - 100000	m%	1	500	Zero point clamping
FrHiHiLim	0.000 - 100.000	Hz	0.001	65.000	High High limit (physical value)
FrHiLim	0.000 - 100.000	Hz	0.001	63.000	High limit (physical value)
FrLowLim	0.000 - 100.000	Hz	0.001	47.000	Low limit (physical value)
FrLowLowLim	0.000 - 100.000	Hz	0.001	45.000	Low Low limit (physical value)
FrLimHyst	0.000 - 100.000	%	0.001	5.000	Hysteresis value in % of range (common for all limits)
UAmpComp5	-10.000 - 10.000	%	0.001	0.000	Amplitude factor to calibrate voltage at 5% of Ur
UAmpComp30	-10.000 - 10.000	%	0.001	0.000	Amplitude factor to calibrate voltage at 30% of Ur
UAmpComp100	-10.000 - 10.000	%	0.001	0.000	Amplitude factor to calibrate voltage at 100% of Ur
IAmpComp5	-10.000 - 10.000	%	0.001	0.000	Amplitude factor to calibrate current at 5% of Ir
IAmpComp30	-10.000 - 10.000	%	0.001	0.000	Amplitude factor to calibrate current at 30% of Ir
IAmpComp100	-10.000 - 10.000	%	0.001	0.000	Amplitude factor to calibrate current at 100% of Ir
IAngComp5	-10.000 - 10.000	Deg	0.001	0.000	Angle calibration for current at 5% of Ir
IAngComp30	-10.000 - 10.000	Deg	0.001	0.000	Angle calibration for current at 30% of Ir
IAngComp100	-10.000 - 10.000	Deg	0.001	0.000	Angle calibration for current at 100% of Ir

12.1.2.5 Monitored data

Table 341: CVMMXN Monitored data

Name	Type	Values (Range)	Unit	Description
S	REAL	-	MVA	Apparent power magnitude of deadband value
P	REAL	-	MW	Active power magnitude of deadband value
Q	REAL	-	MVA _r	Reactive power magnitude of deadband value
PF	REAL	-	-	Power factor magnitude of deadband value
U	REAL	-	kV	Calculated voltage magnitude of deadband value
I	REAL	-	A	Calculated current magnitude of deadband value
F	REAL	-	Hz	System frequency magnitude of deadband value

12.1.3 Phase current measurement CMMXU

12.1.3.1 Identification

Function description	IEC 61850 identification	IEC 60617 identification	ANSI/IEEE C37.2 device number
Phase current measurement	CMMXU	/	-

12.1.3.2 Function block

The available function blocks of an IED are depending on the actual hardware (TRM) and the logic configuration made in PCM600.

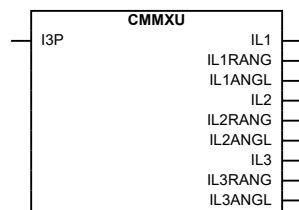

Figure 198: CMMXU function block

12.1.3.3 Signals

Table 342: CMMXU Input signals

Name	Type	Default	Description
I3P	GROUP SIGNAL	-	Three phase group signal for current inputs

Table 343: CMMXU Output signals

Name	Type	Description
IL1	REAL	IL1 Amplitude
IL1RANG	INTEGER	IL1 Amplitude range
IL1ANGL	REAL	IL1 Angle
IL2	REAL	IL2 Amplitude
IL2RANG	INTEGER	IL2 Amplitude range
IL2ANGL	REAL	IL2 Angle
IL3	REAL	IL3 Amplitude
IL3RANG	INTEGER	IL3 Amplitude range
IL3ANGL	REAL	IL3 Angle

12.1.3.4 Settings

Table 344: CMMXU Non group settings (basic)

Name	Values (Range)	Unit	Step	Default	Description
Operation	Off On	-	-	Off	Operation Off / On
GlobalBaseSel	1 - 6	-	1	1	Selection of one of the Global Base Value groups
ILDbReplnt	1 - 300	Type	1	10	Cycl: Report interval (s), Db: In % of range, Int Db: In %s
ILMax	0 - 500000	A	1	1300	Maximum value
ILRepTyp	Cyclic Dead band Int deadband	-	-	Dead band	Reporting type
ILAngDbReplnt	1 - 300	Type	1	10	Cycl: Report interval (s), Db: In % of range, Int Db: In %s

Table 345: CMMXU Non group settings (advanced)

Name	Values (Range)	Unit	Step	Default	Description
ILZeroDb	0 - 100000	m%	1	500	Zero point clamping
ILHiHiLim	0 - 500000	A	1	1200	High High limit (physical value)
ILHiLim	0 - 500000	A	1	1100	High limit (physical value)
ILLowLim	0 - 500000	A	1	0	Low limit (physical value)
ILLowLowLim	0 - 500000	A	1	0	Low Low limit (physical value)

Table continues on next page

Name	Values (Range)	Unit	Step	Default	Description
ILMin	0 - 500000	A	1	0	Minimum value
ILLimHys	0.000 - 100.000	%	0.001	5.000	Hysteresis value in % of range and is common for all limits
IComp5	-10.000 - 10.000	%	0.001	0.000	Amplitude factor to calibrate current at 5% of I _r
IComp30	-10.000 - 10.000	%	0.001	0.000	Amplitude factor to calibrate current at 30% of I _r
IComp100	-10.000 - 10.000	%	0.001	0.000	Amplitude factor to calibrate current at 100% of I _r
IAngComp5	-10.000 - 10.000	Deg	0.001	0.000	Angle calibration for current at 5% of I _r
IAngComp30	-10.000 - 10.000	Deg	0.001	0.000	Angle calibration for current at 30% of I _r
IAngComp100	-10.000 - 10.000	Deg	0.001	0.000	Angle calibration for current at 100% of I _r

12.1.3.5 Monitored data

Table 346: CMMXU Monitored data

Name	Type	Values (Range)	Unit	Description
IL1	REAL	-	A	IL1 Amplitude
IL1ANGL	REAL	-	deg	IL1 Angle
IL2	REAL	-	A	IL2 Amplitude
IL2ANGL	REAL	-	deg	IL2 Angle
IL3	REAL	-	A	IL3 Amplitude
IL3ANGL	REAL	-	deg	IL3 Angle

12.1.4 Phase-phase voltage measurement VMMXU

12.1.4.1 Identification

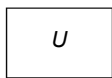
Function description	IEC 61850 identification	IEC 60617 identification	ANSI/IEEE C37.2 device number
Phase-phase voltage measurement	VMMXU		-

12.1.4.2 Function block

The available function blocks of an IED are depending on the actual hardware (TRM) and the logic configuration made in PCM600.

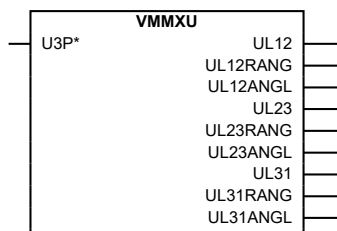

IEC08000223-2-en.vsd

Figure 199: VMMXU function block

12.1.4.3 Signals

Table 347: VMMXU Input signals

Name	Type	Default	Description
U3P	GROUP SIGNAL	-	Three phase group signal for voltage inputs

Table 348: VMMXU Output signals

Name	Type	Description
UL12	REAL	UL12 Amplitude
UL12RANG	INTEGER	UL12 Amplitude range
UL12ANGL	REAL	UL12 Angle
UL23	REAL	UL23 Amplitude
UL23RANG	INTEGER	UL23 Amplitude range
UL23ANGL	REAL	UL23 Angle
UL31	REAL	UL31 Amplitude
UL31RANG	INTEGER	UL31Amplitude range
UL31ANGL	REAL	UL31 Angle

12.1.4.4 Settings

Table 349: VMMXU Non group settings (basic)

Name	Values (Range)	Unit	Step	Default	Description
Operation	Off On	-	-	Off	Operation Off / On
GlobalBaseSel	1 - 6	-	1	1	Selection of one of the Global Base Value groups
ULDbReplnt	1 - 300	Type	1	10	Cycl: Report interval (s), Db: In % of range, Int Db: In %s
ULMax	0 - 4000000	V	1	170000	Maximum value
ULRepTyp	Cyclic Dead band Int deadband	-	-	Dead band	Reporting type
ULAngDbReplnt	1 - 300	Type	1	10	Cycl: Report interval (s), Db: In % of range, Int Db: In %s

Table 350: VMMXU Non group settings (advanced)

Name	Values (Range)	Unit	Step	Default	Description
ULZeroDb	0 - 100000	m%	1	500	Zero point clamping
ULHiHiLim	0 - 4000000	V	1	160000	High High limit (physical value)
ULHiLim	0 - 4000000	V	1	150000	High limit (physical value)
ULLowLim	0 - 4000000	V	1	125000	Low limit (physical value)
ULLowLowLim	0 - 4000000	V	1	115000	Low Low limit (physical value)
ULMin	0 - 4000000	V	1	0	Minimum value
ULLimHys	0.000 - 100.000	V	0.001	5.000	Hysteresis value in % of range and is common for all limits

12.1.4.5 Monitored data

Table 351: VMMXU Monitored data

Name	Type	Values (Range)	Unit	Description
UL12	REAL	-	kV	UL12 Amplitude
UL12ANGL	REAL	-	deg	UL12 Angle
UL23	REAL	-	kV	UL23 Amplitude
UL23ANGL	REAL	-	deg	UL23 Angle
UL31	REAL	-	kV	UL31 Amplitude
UL31ANGL	REAL	-	deg	UL31 Angle

12.1.5 Current sequence component measurement CMSQI

12.1.5.1 Identification

Function description	IEC 61850 identification	IEC 60617 identification	ANSI/IEEE C37.2 device number
Current sequence component measurement	CMSQI	11, 12, 10	-

12.1.5.2 Function block

The available function blocks of an IED are depending on the actual hardware (TRM) and the logic configuration made in PCM600.

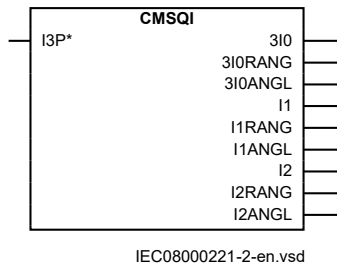

Figure 200: CMSQI function block

12.1.5.3 Signals

Table 352: CMSQI Input signals

Name	Type	Default	Description
I3P	GROUP SIGNAL	-	Three phase group signal for current inputs

Table 353: CMSQI Output signals

Name	Type	Description
3I0	REAL	3I0 Amplitude
3I0RANG	INTEGER	3I0 Amplitude range
3I0ANGL	REAL	3I0 Angle
I1	REAL	I1 Amplitude
I1RANG	INTEGER	I1Amplitude range
I1ANGL	REAL	I1 Angle
I2	REAL	I2 Amplitude
I2RANG	INTEGER	I2 Amplitude range
I2ANGL	REAL	I2Angle

12.1.5.4 Settings

Table 354: CMSQI Non group settings (basic)

Name	Values (Range)	Unit	Step	Default	Description
Operation	Off On	-	-	Off	Operation Off / On
3I0DbRepInt	1 - 300	Type	1	10	Cycl: Report interval (s), Db: In % of range, Int Db: In %s
3I0Min	0 - 500000	A	1	0	Minimum value
3I0Max	0 - 500000	A	1	3300	Maximum value
3I0RepTyp	Cyclic Dead band Int deadband	-	-	Dead band	Reporting type
3I0LimHys	0.000 - 100.000	%	0.001	5.000	Hysteresis value in % of range and is common for all limits

Table continues on next page

Name	Values (Range)	Unit	Step	Default	Description
3I0AngDbRepInt	1 - 300	Type	1	10	Cycl: Report interval (s), Db: In % of range, Int Db: In %s
I1DbRepInt	1 - 300	Type	1	10	Cycl: Report interval (s), Db: In % of range, Int Db: In %s
I1Min	0 - 500000	A	1	0	Minimum value
I1Max	0 - 500000	A	1	1300	Maximum value
I1RepTyp	Cyclic Dead band Int deadband	-	-	Dead band	Reporting type
I1AngDbRepInt	1 - 300	Type	1	10	Cycl: Report interval (s), Db: In % of range, Int Db: In %s
I2DbRepInt	1 - 300	Type	1	10	Cycl: Report interval (s), Db: In % of range, Int Db: In %s
I2Min	0 - 500000	A	1	0	Minimum value
I2Max	0 - 500000	A	1	1300	Maximum value
I2RepTyp	Cyclic Dead band Int deadband	-	-	Dead band	Reporting type
I2LimHys	0.000 - 100.000	%	0.001	5.000	Hysteresis value in % of range and is common for all limits
I2AngDbRepInt	1 - 300	Type	1	10	Cycl: Report interval (s), Db: In % of range, Int Db: In %s

Table 355: CMSQI Non group settings (advanced)

Name	Values (Range)	Unit	Step	Default	Description
3I0ZeroDb	0 - 100000	m%	1	500	Zero point clamping
3I0HiHiLim	0 - 500000	A	1	3600	High High limit (physical value)
3I0HiLim	0 - 500000	A	1	3300	High limit (physical value)
3I0LowLim	0 - 500000	A	1	0	Low limit (physical value)
3I0LowLowLim	0 - 500000	A	1	0	Low Low limit (physical value)
I1ZeroDb	0 - 100000	m%	1	500	Zero point clamping
I1HiHiLim	0 - 500000	A	1	1200	High High limit (physical value)
I1HiLim	0 - 500000	A	1	1100	High limit (physical value)
I1LowLim	0 - 500000	A	1	0	Low limit (physical value)
I1LowLowLim	0 - 500000	A	1	0	Low Low limit (physical value)
I1LimHys	0.000 - 100.000	%	0.001	5.000	Hysteresis value in % of range and is common for all limits
I2ZeroDb	0 - 100000	m%	1	500	Zero point clamping
I2HiHiLim	0 - 500000	A	1	1200	High High limit (physical value)
I2HiLim	0 - 500000	A	1	1100	High limit (physical value)
I2LowLim	0 - 500000	A	1	0	Low limit (physical value)
I2LowLowLim	0 - 500000	A	1	0	Low Low limit (physical value)

12.1.5.5 Monitored data

Table 356: CMSQI Monitored data

Name	Type	Values (Range)	Unit	Description
3I0	REAL	-	A	3I0 Amplitude
3I0ANGL	REAL	-	deg	3I0 Angle
I1	REAL	-	A	I1 Amplitude
I1ANGL	REAL	-	deg	I1 Angle
I2	REAL	-	A	I2 Amplitude
I2ANGL	REAL	-	deg	I2Angle

12.1.6 Voltage sequence measurement VMSQI

12.1.6.1 Identification

Function description	IEC 61850 identification	IEC 60617 identification	ANSI/IEEE C37.2 device number
Voltage sequence measurement	VMSQI	U1, U2, U0	-

12.1.6.2 Function block

The available function blocks of an IED are depending on the actual hardware (TRM) and the logic configuration made in PCM600.

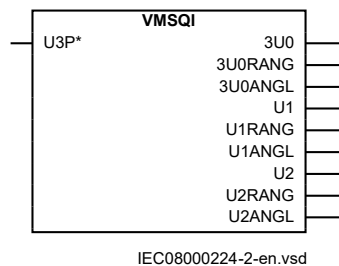

Figure 201: VMSQI function block

12.1.6.3 Signals

Table 357: VMSQI Input signals

Name	Type	Default	Description
U3P	GROUP SIGNAL	-	Three phase group signal for voltage inputs

Table 358: VMSQI Output signals

Name	Type	Description
3U0	REAL	3U0 Amplitude
3UORANG	INTEGER	3U0 Amplitude range
3U0ANGL	REAL	3U0 Angle
U1	REAL	U1 Amplitude
U1RANG	INTEGER	U1 Amplitude range
U1ANGL	REAL	U1 Angle
U2	REAL	U2 Amplitude
U2RANG	INTEGER	U2 Amplitude range
U2ANGL	REAL	U2 Angle

12.1.6.4 Settings

Table 359: VMSQI Non group settings (basic)

Name	Values (Range)	Unit	Step	Default	Description
Operation	Off On	-	-	Off	Operation Off / On
3U0DbReplnt	1 - 300	Type	1	10	Cycl: Report interval (s), Db: In % of range, Int Db: In %s
3U0Min	0 - 2000000	V	1	0	Minimum value
3U0Max	0 - 2000000	V	1	318000	Maximum value
3U0RepTyp	Cyclic Dead band Int deadband	-	-	Dead band	Reporting type
3U0LimHys	0.000 - 100.000	%	0.001	5.000	Hysteresis value in % of range and is common for all limits
3U0AngDbReplnt	1 - 300	Type	1	10	Cycl: Report interval (s), Db: In % of range, Int Db: In %s
U1DbReplnt	1 - 300	Type	1	10	Cycl: Report interval (s), Db: In % of range, Int Db: In %s
U1Min	0 - 2000000	V	1	0	Minimum value
U1Max	0 - 2000000	V	1	106000	Maximum value
U1RepTyp	Cyclic Dead band Int deadband	-	-	Dead band	Reporting type
U1AngDbReplnt	1 - 300	Type	1	10	Cycl: Report interval (s), Db: In % of range, Int Db: In %s
U2DbReplnt	1 - 300	Type	1	10	Cycl: Report interval (s), Db: In % of range, Int Db: In %s
U2Min	0 - 2000000	V	1	0	Minimum value
U2Max	0 - 2000000	V	1	106000	Maximum value

Table continues on next page

Name	Values (Range)	Unit	Step	Default	Description
U2RepTyp	Cyclic Dead band Int deadband	-	-	Dead band	Reporting type
U2LimHys	0.000 - 100.000	%	0.001	5.000	Hysteresis value in % of range and is common for all limits
U2AngDbReplnt	1 - 300	Type	1	10	Cycl: Report interval (s), Db: In % of range, Int Db: In %s

Table 360: VMSQI Non group settings (advanced)

Name	Values (Range)	Unit	Step	Default	Description
3U0ZeroDb	0 - 100000	m%	1	500	Zero point clamping
3U0HiHiLim	0 - 2000000	V	1	288000	High High limit (physical value)
3U0HiLim	0 - 2000000	V	1	258000	High limit (physical value)
3U0LowLim	0 - 2000000	V	1	213000	Low limit (physical value)
3U0LowLowLim	0 - 2000000	V	1	198000	Low Low limit (physical value)
U1ZeroDb	0 - 100000	m%	1	500	Zero point clamping
U1HiHiLim	0 - 2000000	V	1	96000	High High limit (physical value)
U1HiLim	0 - 2000000	V	1	86000	High limit (physical value)
U1LowLim	0 - 2000000	V	1	71000	Low limit (physical value)
U1LowLowLim	0 - 2000000	V	1	66000	Low Low limit (physical value)
U1LimHys	0.000 - 100.000	%	0.001	5.000	Hysteresis value in % of range and is common for all limits
U2ZeroDb	0 - 100000	m%	1	500	Zero point clamping
U2HiHiLim	0 - 2000000	V	1	96000	High High limit (physical value)
U2HiLim	0 - 2000000	V	1	86000	High limit (physical value)
U2LowLim	0 - 2000000	V	1	71000	Low limit (physical value)
U2LowLowLim	0 - 2000000	V	1	66000	Low Low limit (physical value)

12.1.6.5 Monitored data

Table 361: VMSQI Monitored data

Name	Type	Values (Range)	Unit	Description
3U0	REAL	-	kV	3U0 Amplitude
3U0ANGL	REAL	-	deg	3U0 Angle
U1	REAL	-	kV	U1 Amplitude
U1ANGL	REAL	-	deg	U1 Angle
U2	REAL	-	kV	U2 Amplitude
U2ANGL	REAL	-	deg	U2 Angle

12.1.7 Phase-neutral voltage measurement VNMMXU

12.1.7.1 Identification

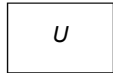
Function description	IEC 61850 identification	IEC 60617 identification	ANSI/IEEE C37.2 device number
Phase-neutral voltage measurement	VNMMXU		-

12.1.7.2 Function block

The available function blocks of an IED are depending on the actual hardware (TRM) and the logic configuration made in PCM600.

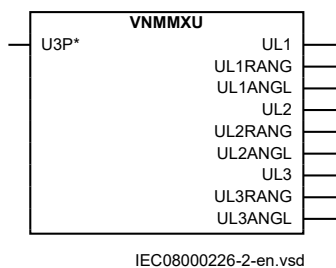

Figure 202: VNMMXU function block

12.1.7.3 Signals

Table 362: VNMMXU Input signals

Name	Type	Default	Description
U3P	GROUP SIGNAL	-	Three phase group signal for voltage inputs

Table 363: VNMMXU Output signals

Name	Type	Description
UL1	REAL	UL1 Amplitude, magnitude of reported value
UL1RANG	INTEGER	UL1 Amplitude range
UL1ANGL	REAL	UL1 Angle, magnitude of reported value
UL2	REAL	UL2 Amplitude, magnitude of reported value
UL2RANG	INTEGER	UL2 Amplitude range
UL2ANGL	REAL	UL2 Angle, magnitude of reported value
UL3	REAL	UL3 Amplitude, magnitude of reported value
UL3RANG	INTEGER	UL3 Amplitude range
UL3ANGL	REAL	UL3 Angle, magnitude of reported value

12.1.7.4 Settings

Table 364: VNMMXU Non group settings (basic)

Name	Values (Range)	Unit	Step	Default	Description
Operation	Off On	-	-	Off	Operation Mode On / Off
GlobalBaseSel	1 - 6	-	1	1	Selection of one of the Global Base Value groups
UDbRepInt	1 - 300	Type	1	10	Cycl: Report interval (s), Db: In % of range, Int Db: In %s
UMax	0 - 2000000	V	1	106000	Maximum value
URepTyp	Cyclic Dead band Int deadband	-	-	Dead band	Reporting type
ULimHys	0.000 - 100.000	V	0.001	5.000	Hysteresis value in % of range and is common for all limits
UAngDbRepInt	1 - 300	Type	1	10	Cycl: Report interval (s), Db: In % of range, Int Db: In %s

Table 365: VNMMXU Non group settings (advanced)

Name	Values (Range)	Unit	Step	Default	Description
UZeroDb	0 - 100000	m%	1	500	Zero point clamping in 0,001% of range
UHiHiLim	0 - 2000000	V	1	96000	High High limit (physical value)
UHiLim	0 - 2000000	V	1	86000	High limit (physical value)
ULowLim	0 - 2000000	V	1	71000	Low limit (physical value)
ULowLowLim	0 - 2000000	V	1	66000	Low Low limit (physical value)
UMin	0 - 2000000	V	1	0	Minimum value

12.1.7.5 Monitored data

Table 366: VNMMXU Monitored data

Name	Type	Values (Range)	Unit	Description
UL1	REAL	-	kV	UL1 Amplitude, magnitude of reported value
UL1ANGL	REAL	-	deg	UL1 Angle, magnitude of reported value
UL2	REAL	-	kV	UL2 Amplitude, magnitude of reported value
UL2ANGL	REAL	-	deg	UL2 Angle, magnitude of reported value
UL3	REAL	-	kV	UL3 Amplitude, magnitude of reported value
UL3ANGL	REAL	-	deg	UL3 Angle, magnitude of reported value

12.1.8 Operation principle

12.1.8.1 Measurement supervision

The protection, control, and monitoring IEDs have functionality to measure and further process information for currents and voltages obtained from the pre-processing blocks. The number of processed alternate measuring quantities depends on the type of IED and built-in options.

The information on measured quantities is available for the user at different locations:

- Locally by means of the local HMI
- Remotely using the monitoring tool within PCM600 or over the station bus
- Internally by connecting the analogue output signals to the Disturbance Report function

Phase angle reference

All phase angles are presented in relation to a defined reference channel. The General setting parameter *PhaseAngleRef* defines the reference. The *PhaseAngleRef* is set in local HMI under: **Configuration/Analogue modules/Reference** channel service values.

Zero point clamping

Measured value below zero point clamping limit is forced to zero. This allows the noise in the input signal to be ignored. The zero point clamping limit is a general setting (*XZeroDb* where X equals S, P, Q, PF, U, I, F, IL1-3, UL1-3, UL12-31, I1, I2, 3I0, U1, U2 or 3U0). Observe that this measurement supervision zero point clamping might be overridden by the zero point clamping used for the measurement values within CVMMXN.

Continuous monitoring of the measured quantity

Users can continuously monitor the measured quantity available in each function block by means of four defined operating thresholds, see figure 203. The monitoring has two different modes of operating:

- Overfunction, when the measured current exceeds the High limit (*XHiLim*) or High-high limit (*XHiHiLim*) pre-set values
- Underfunction, when the measured current decreases under the Low limit (*XLowLim*) or Low-low limit (*XLowLowLim*) pre-set values.

X_RANGE is illustrated in figure 203.

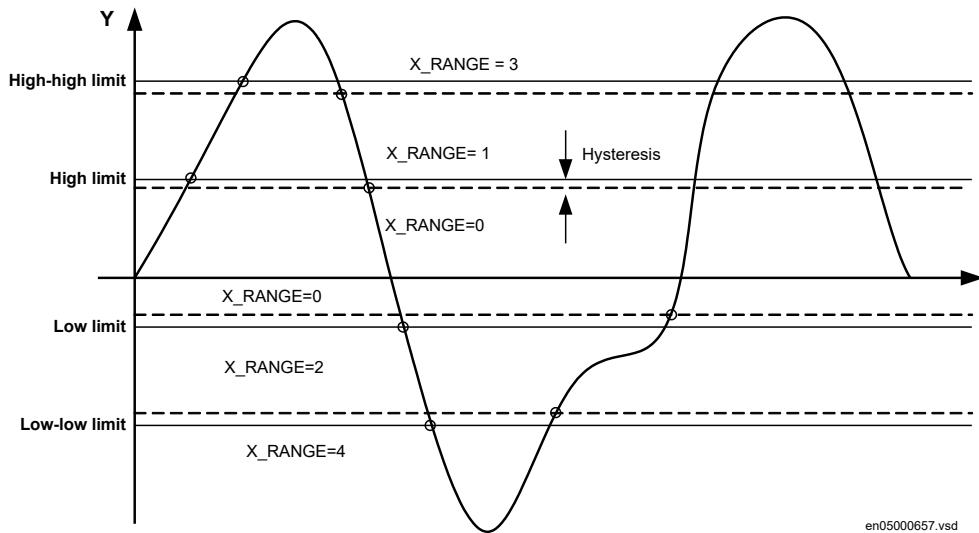

Figure 203: Presentation of operating limits

Each analogue output has one corresponding supervision level output (X_RANGE). The output signal is an integer in the interval 0-4 (0: Normal, 1: High limit exceeded, 3: High-high limit exceeded, 2: below Low limit and 4: below Low-low limit). The output may be connected to a measurement expander block (XP (RANGE_XP)) to get measurement supervision as binary signals.

The logical value of the functional output signals changes according to figure 203.

The user can set the hysteresis ($XLimHyst$), which determines the difference between the operating and reset value at each operating point, in wide range for each measuring channel separately. The hysteresis is common for all operating values within one channel.

Actual value of the measured quantity

The actual value of the measured quantity is available locally and remotely. The measurement is continuous for each measured quantity separately, but the reporting of the value to the higher levels depends on the selected reporting mode. The following basic reporting modes are available:

- Cyclic reporting (*Cyclic*)
- Amplitude dead-band supervision (*Dead band*)
- Integral dead-band supervision (*Int deadband*)

Cyclic reporting

The cyclic reporting of measured value is performed according to chosen setting ($XRepTyp$). The measuring channel reports the value independent of amplitude or integral dead-band reporting.

In addition to the normal cyclic reporting the IED also report spontaneously when measured value passes any of the defined threshold limits.

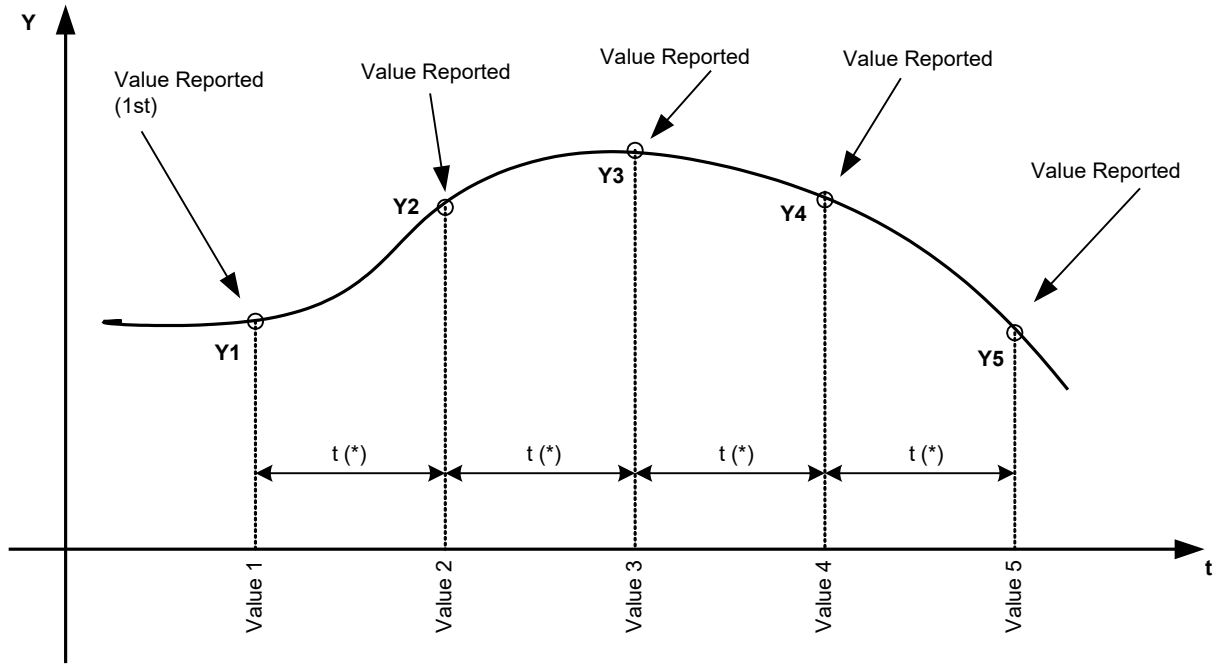

(*)Set value for t: XDbReplnt

en05000500.vsd

Figure 204: Periodic reporting

Amplitude dead-band supervision

If a measuring value is changed, compared to the last reported value, and the change is larger than the $\pm\Delta Y$ pre-defined limits that are set by user (*UDbRepln*), then the measuring channel reports the new value to a higher level. This limits the information flow to a minimum necessary. Figure 205 shows an example with the amplitude dead-band supervision. The picture is simplified: the process is not continuous but the values are evaluated with a time interval of one execution cycle from each other.

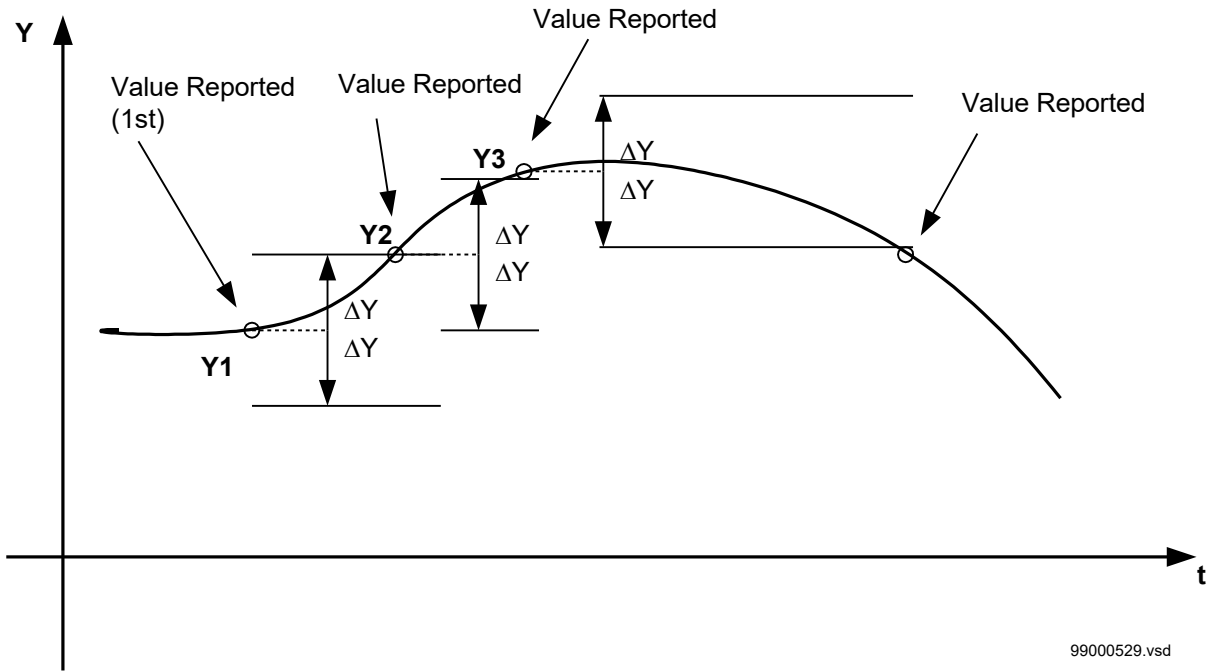

Figure 205: Amplitude dead-band supervision reporting

After the new value is reported, the $\pm\Delta Y$ limits for dead-band are automatically set around it. The new value is reported only if the measured quantity changes more than defined by the $\pm\Delta Y$ set limits.

Integral dead-band reporting

The measured value is reported if the time integral of all changes exceeds the pre-set limit (*XDbReplnt*), figure 206, where an example of reporting with integral dead-band supervision is shown. The picture is simplified: the process is not continuous but the values are evaluated with a time interval of one execution cycle from each other.

The last value reported, Y1 in figure 206 serves as a basic value for further measurement. A difference is calculated between the last reported and the newly measured value and is multiplied by the time increment (discrete integral). The absolute values of these integral values are added until the pre-set value is exceeded. This occurs with the value Y2 that is reported and set as a new base for the following measurements (as well as for the values Y3, Y4 and Y5).

The integral dead-band supervision is particularly suitable for monitoring signals with small variations that can last for relatively long periods.

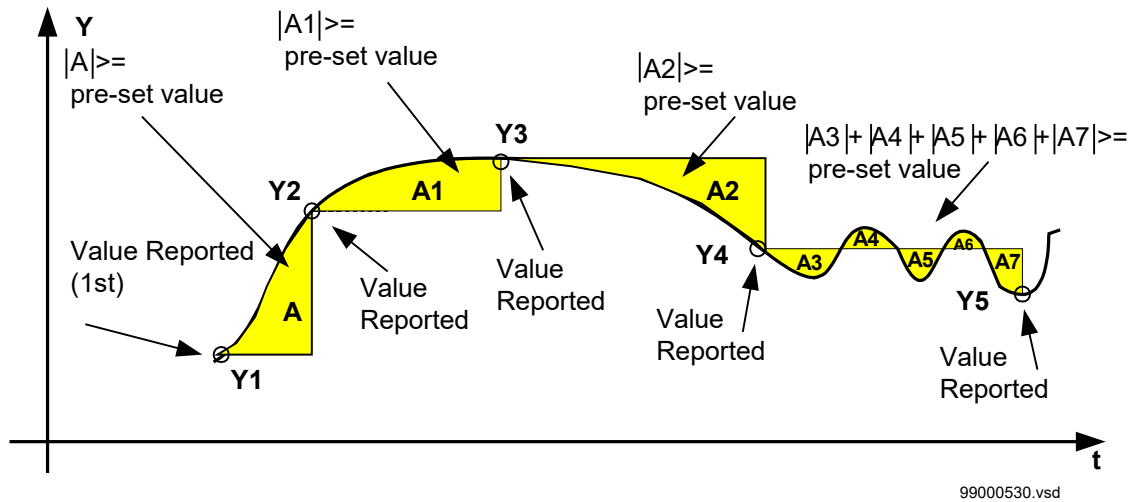

Figure 206: Reporting with integral dead-band supervision

12.1.8.2 Measurements CVMMXN

Mode of operation

The measurement function must be connected to three-phase current and three-phase voltage input in the configuration tool (group signals), but it is capable to measure and calculate above mentioned quantities in nine different ways depending on the available VT inputs connected to the IED. The end user can freely select by a parameter setting, which one of the nine available measuring modes shall be used within the function. Available options are summarized in the following table:

	Set value for parameter "Mode"	Formula used for complex, three-phase power calculation	Formula used for voltage and current magnitude calculation	Comment
1	L1, L2, L3	$\bar{S} = \overline{U_{L1}} \cdot \overline{I_{L1}^*} + \overline{U_{L2}} \cdot \overline{I_{L2}^*} + \overline{U_{L3}} \cdot \overline{I_{L3}^*}$	$U = (\overline{ U_{L1} } + \overline{ U_{L2} } + \overline{ U_{L3} }) / \sqrt{3}$ $I = (\overline{ I_{L1} } + \overline{ I_{L2} } + \overline{ I_{L3} }) / 3$	Used when three phase-to-earth voltages are available
2	Arone	$\bar{S} = \overline{U_{L1L2}} \cdot \overline{I_{L1}^*} - \overline{U_{L2L3}} \cdot \overline{I_{L3}^*}$ (Equation 40)	$U = (\overline{ U_{L1L2} } + \overline{ U_{L2L3} }) / 2$ $I = (\overline{ I_{L1} } + \overline{ I_{L3} }) / 2$ (Equation 41)	Used when three two phase-to-phase voltages are available
3	PosSeq	$\bar{S} = 3 \cdot \overline{U_{PosSeq}} \cdot \overline{I_{PosSeq}^*}$ (Equation 42)	$U = \sqrt{3} \cdot \overline{ U_{PosSeq} }$ $I = \overline{ I_{PosSeq} }$ (Equation 43)	Used when only symmetrical three phase power shall be measured
4	L1L2	$\bar{S} = \overline{U_{L1L2}} \cdot (\overline{I_{L1}^*} - \overline{I_{L2}^*})$ (Equation 44)	$U = \overline{ U_{L1L2} }$ $I = (\overline{ I_{L1} } + \overline{ I_{L2} }) / 2$ (Equation 45)	Used when only U_{L1L2} phase-to-phase voltage is available

Table continues on next page

	Set value for parameter "Mode"	Formula used for complex, three-phase power calculation	Formula used for voltage and current magnitude calculation	Comment
5	L2L3	$\bar{S} = \overline{U_{L2L3}} \cdot (\overline{I_{L2}^*} - \overline{I_{L3}^*})$ (Equation 46)	$U = \overline{U_{L2L3}} $ $I = (\overline{I_{L2}} + \overline{I_{L3}}) / 2$ (Equation 47)	Used when only U_{L2L3} phase-to-phase voltage is available
6	L3L1	$\bar{S} = \overline{U_{L3L1}} \cdot (\overline{I_{L3}^*} - \overline{I_{L1}^*})$ (Equation 48)	$U = \overline{U_{L3L1}} $ $I = (\overline{I_{L3}} + \overline{I_{L1}}) / 2$ (Equation 49)	Used when only U_{L3L1} phase-to-phase voltage is available
7	L1	$\bar{S} = 3 \cdot \overline{U_{L1}} \cdot \overline{I_{L1}^*}$ (Equation 50)	$U = \sqrt{3} \cdot \overline{U_{L1}} $ $I = \overline{I_{L1}} $ (Equation 51)	Used when only U_{L1} phase-to-earth voltage is available
8	L2	$\bar{S} = 3 \cdot \overline{U_{L2}} \cdot \overline{I_{L2}^*}$ (Equation 52)	$U = \sqrt{3} \cdot \overline{U_{L2}} $ $I = \overline{I_{L2}} $ (Equation 53)	Used when only U_{L2} phase-to-earth voltage is available
9	L3	$\bar{S} = 3 \cdot \overline{U_{L3}} \cdot \overline{I_{L3}^*}$ (Equation 54)	$U = \sqrt{3} \cdot \overline{U_{L3}} $ $I = \overline{I_{L3}} $ (Equation 55)	Used when only U_{L3} phase-to-earth voltage is available
* means complex conjugated value				

It shall be noted that only in the first two operating modes that is, 1 & 2 the measurement function calculates exact three-phase power. In other operating modes that is, from 3 to 9 it calculates the three-phase power under assumption that the power system is fully symmetrical. Once the complex apparent power is calculated then the P, Q, S, & PF are calculated in accordance with the following formulas:

$$P = \text{Re}(\bar{S}) \tag{Equation 56}$$

$$Q = \text{Im}(\bar{S}) \tag{Equation 57}$$

$$S = |\bar{S}| = \sqrt{P^2 + Q^2} \tag{Equation 58}$$

$$PF = \cos\varphi = \frac{P}{S}$$

(Equation 59)

Additionally to the power factor value the two binary output signals from the function are provided which indicates the angular relationship between current and voltage phasors. Binary output signal ILAG is set to one when current phasor is lagging behind voltage phasor. Binary output signal ILEAD is set to one when current phasor is leading the voltage phasor.

Each analogue output has a corresponding supervision level output (X_RANGE). The output signal is an integer in the interval 0-4, see section "[Measurement supervision](#)".

Calibration of analog inputs

Measured currents and voltages used in the CVMMXN function can be calibrated to get class 0.5 measuring accuracy. This is achieved by amplitude and angle compensation at 5, 30 and 100% of rated current and voltage. The compensation below 5% and above 100% is constant and linear in between, see example in figure [207](#).

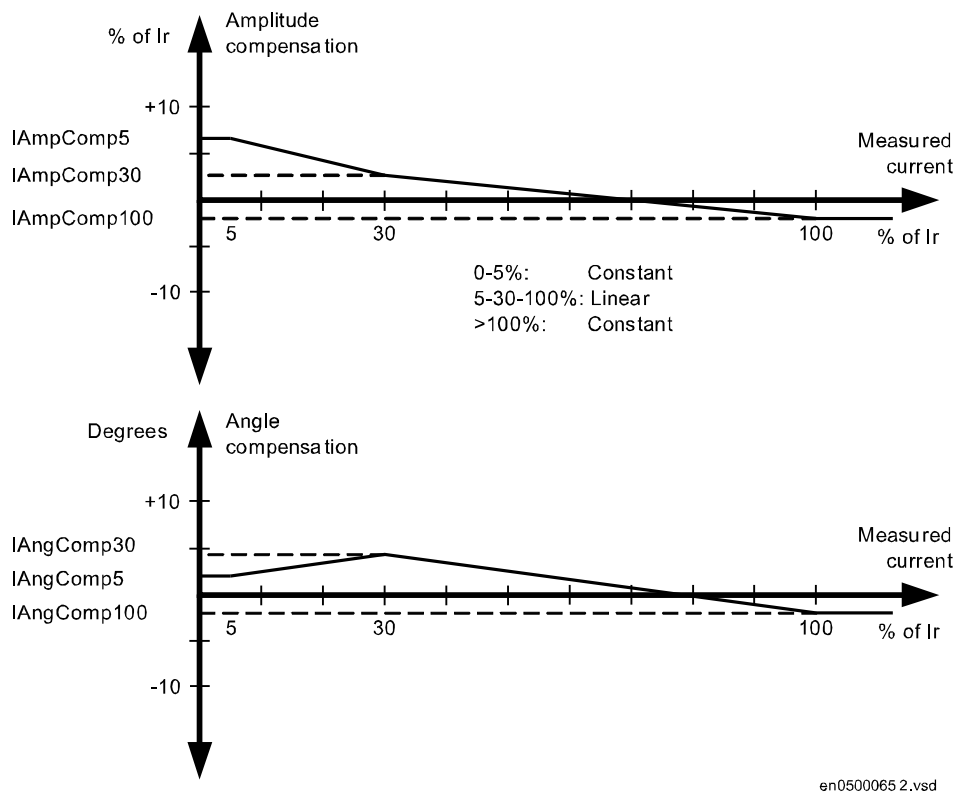

en0500065 2.vsd

Figure 207: Calibration curves

The first current and voltage phase in the group signals will be used as reference and the amplitude and angle compensation will be used for related input signals.

Low pass filtering

In order to minimize the influence of the noise signal on the measurement it is possible to introduce the recursive, low pass filtering of the measured values for P, Q, S, U, I and power factor. This will make slower measurement response to the step changes in the measured quantity. Filtering is performed in accordance with the following recursive formula:

$$X = k \cdot X_{Old} + (1 - k) \cdot X_{Calculated}$$

(Equation 60)

where:

- X is a new measured value (that is P, Q, S, U, I or PF) to be given out from the function
- X_{Old} is the measured value given from the measurement function in previous execution cycle
- X_{Calculated} is the new calculated value in the present execution cycle
- k is settable parameter by the end user which influence the filter properties

Default value for parameter *k* is 0.00. With this value the new calculated value is immediately given out without any filtering (that is, without any additional delay). When *k* is set to value bigger than 0, the filtering is enabled. Appropriate value of *k* shall be determined separately for every application. Some typical value for *k*=0.14.

Zero point clamping

In order to avoid erroneous measurements when either current or voltage signal is not present, the amplitude level for current and voltage measurement is forced to zero. When either current or voltage measurement is forced to zero automatically the measured values for power (P, Q & S) and power factor are forced to zero as well. Since the measurement supervision functionality, included in the CVMMXN function, is using these values the zero clamping will influence the subsequent supervision (observe the possibility to do zero point clamping within measurement supervision, see section "[Measurement supervision](#)").

Compensation facility

In order to compensate for small amplitude and angular errors in the complete measurement chain (CT error, VT error, IED input transformer errors and so on.) it is possible to perform on site calibration of the power measurement. This is achieved by setting the complex constant which is then internally used within the function to multiply the calculated complex apparent power S. This constant is set as amplitude (setting parameter *PowAmpFact*, default value 1.000) and angle (setting parameter *PowAngComp*, default value 0.0 degrees). Default values for these two parameters are done in such way that they do not influence internally calculated value (complex constant has default value 1). In this way calibration, for specific operating range (for example, around rated power) can be done at site. However, to perform this calibration it is necessary to have an external power meter with high accuracy class available.

Directionality

CTStartPoint defines if the CTs earthing point is located towards or from the protected object under observation. If everything is properly set power is always measured towards protection object.

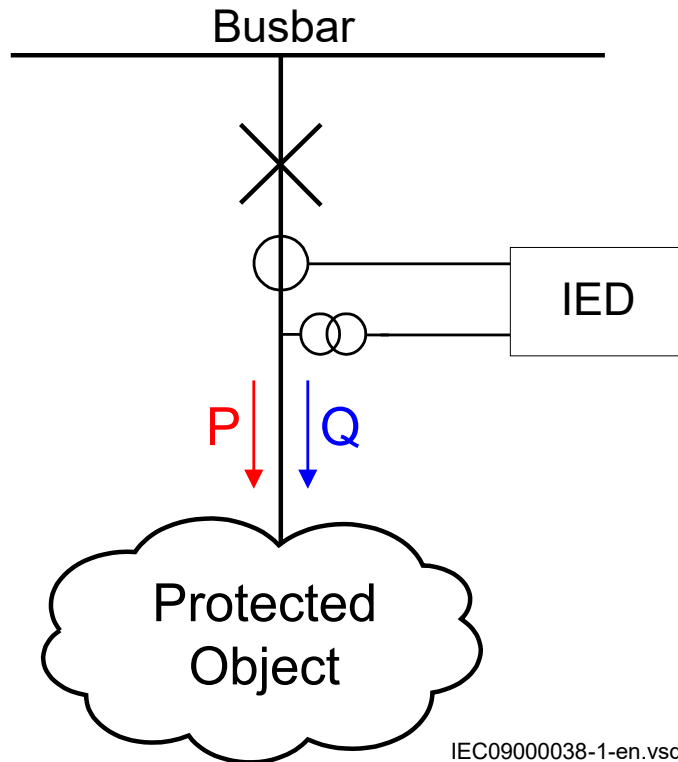

Figure 208: Internal IED directionality convention for P & Q measurements

Practically, it means that active and reactive power will have positive values when they flow from the busbar towards the protected object and they will have negative values when they flow from the protected object towards the busbar.

In some application, for example, when power is measured on the secondary side of the power transformer it might be desirable, from the end client point of view, to have actually opposite directional convention for active and reactive power measurements. This can be easily achieved by setting parameter *PowAngComp* to value of 180.0 degrees. With such setting the active and reactive power will have positive values when they flow from the protected object towards the busbar.

Frequency

Frequency is actually not calculated within measurement block. It is simply obtained from the pre-processing block and then just given out from the measurement block as an output.

12.1.8.3 Phase current measurement CMMXU

The Phase current measurement (CMMXU) function must be connected to three-phase current input in the configuration tool to be operable. Currents handled in the function can be calibrated to get better than class 0.5 measuring accuracy for internal use, on the outputs and IEC 61850. This is achieved by amplitude and angle compensation at 5, 30 and 100% of rated current. The compensation below 5% and above 100% is constant and linear in between, see figure 207.

Phase currents (amplitude and angle) are available on the outputs and each amplitude output has a corresponding supervision level output (ILx_RANG). The supervision output signal is an integer in the interval 0-4, see section "[Measurement supervision](#)".

12.1.8.4 Phase-phase and phase-neutral voltage measurements VMMXU, VNMMXU

The voltage function must be connected to three-phase voltage input in the configuration tool to be operable. Voltages are handled in the same way as currents when it comes to class 0.5 calibrations, see above.

The voltages (phase or phase-phase voltage, amplitude and angle) are available on the outputs and each amplitude output has a corresponding supervision level output (ULxy_RANG). The supervision output signal is an integer in the interval 0-4, see section "[Measurement supervision](#)".

12.1.8.5 Voltage and current sequence measurements VMSQI, CMSQI

The measurement functions must be connected to three-phase current (CMSQI) or voltage (VMSQI) input in the configuration tool to be operable. No outputs, other than X_RANG, are calculated within the measuring blocks and it is not possible to calibrate the signals. Input signals are obtained from the pre-processing block and transferred to corresponding output.

Positive, negative and three times zero sequence quantities are available on the outputs (voltage and current, amplitude and angle). Each amplitude output has a corresponding supervision level output (X_RANGE). The output signal is an integer in the interval 0-4, see section "[Measurement supervision](#)".

12.1.9 Technical data

Table 367: CVMMXN, CMMXU, VMMXU, CMSQI, VMSQI, VNMMXU

Function	Range or value	Accuracy
Voltage	$(0.1-1.5) \times U_r$	$\pm 0.5\%$ of U_r at $U \leq U_r$ $\pm 0.5\%$ of U at $U > U_r$
Connected current	$(0.2-4.0) \times I_r$	$\pm 0.5\%$ of I_r at $I \leq I_r$ $\pm 0.5\%$ of I at $I > I_r$
Active power, P	$0.1 \times U_r < U < 1.5 \times U_r$ $0.2 \times I_r < I < 4.0 \times I_r$	$\pm 1.0\%$ of S_r at $S \leq S_r$ $\pm 1.0\%$ of S at $S > S_r$
Reactive power, Q	$0.1 \times U_r < U < 1.5 \times U_r$ $0.2 \times I_r < I < 4.0 \times I_r$	$\pm 1.0\%$ of S_r at $S \leq S_r$ $\pm 1.0\%$ of S at $S > S_r$
Apparent power, S	$0.1 \times U_r < U < 1.5 \times U_r$ $0.2 \times I_r < I < 4.0 \times I_r$	$\pm 1.0\%$ of S_r at $S \leq S_r$ $\pm 1.0\%$ of S at $S > S_r$
Apparent power, S Three phase settings	$\cos \phi = 1$	$\pm 0.5\%$ of S at $S > S_r$ $\pm 0.5\%$ of S_r at $S \leq S_r$
Power factor, $\cos(\phi)$	$0.1 \times U_r < U < 1.5 \times U_r$ $0.2 \times I_r < I < 4.0 \times I_r$	< 0.02

12.2 Event Counter CNTGGIO

12.2.1 Identification

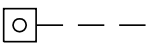
Function description	IEC 61850 identification	IEC 60617 identification	ANSI/IEEE C37.2 device number
Event counter	CNTGGIO		-

12.2.2 Functionality

Event counter CNTGGIO has six counters which are used for storing the number of times each counter input has been activated.

12.2.3 Function block

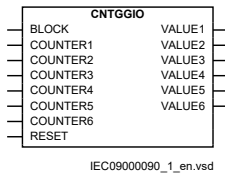

Figure 209: CNTGGIO function block

12.2.4 Signals

Table 368: CNTGGIO Input signals

Name	Type	Default	Description
BLOCK	BOOLEAN	0	Block of function
COUNTER1	BOOLEAN	0	Input for counter 1
COUNTER2	BOOLEAN	0	Input for counter 2
COUNTER3	BOOLEAN	0	Input for counter 3
COUNTER4	BOOLEAN	0	Input for counter 4
COUNTER5	BOOLEAN	0	Input for counter 5
COUNTER6	BOOLEAN	0	Input for counter 6
RESET	BOOLEAN	0	Reset of function

Table 369: CNTGGIO Output signals

Name	Type	Description
VALUE1	INTEGER	Output of counter 1
VALUE2	INTEGER	Output of counter 2
VALUE3	INTEGER	Output of counter 3
VALUE4	INTEGER	Output of counter 4
VALUE5	INTEGER	Output of counter 5
VALUE6	INTEGER	Output of counter 6

12.2.5 Settings

Table 370: CNTGGIO Group settings (basic)

Name	Values (Range)	Unit	Step	Default	Description
Operation	Off On	-	-	Off	Operation Off / On

12.2.6 Monitored data

Table 371: CNTGGIO Monitored data

Name	Type	Values (Range)	Unit	Description
VALUE1	INTEGER	-	-	Output of counter 1
VALUE2	INTEGER	-	-	Output of counter 2
VALUE3	INTEGER	-	-	Output of counter 3
VALUE4	INTEGER	-	-	Output of counter 4
VALUE5	INTEGER	-	-	Output of counter 5
VALUE6	INTEGER	-	-	Output of counter 6

12.2.7 Operation principle

Event counter (CNTGGIO) has six counter inputs. CNTGGIO stores how many times each of the inputs has been activated. The counter memory for each of the six inputs is updated, giving the total number of times the input has been activated, as soon as an input is activated.

To not risk that the flash memory is worn out due to too many writings, a mechanism for limiting the number of writings per time period is included in the product. This however gives as a result that it can take long time, up to several minutes, before a new value is stored in the flash memory. And if a new CNTGGIO value is not stored before auxiliary power interruption, it will be lost. CNTGGIO stored values in flash memory will however not be lost at an auxiliary power interruption.

The function block also has an input BLOCK. At activation of this input all six counters are blocked. The input can for example, be used for blocking the counters at testing. The function block has an input RESET. At activation of this input all six counters are set to 0.

All inputs are configured via PCM600.

12.2.7.1 Reporting

The content of the counters can be read in the local HMI.

Reset of counters can be performed in the local HMI and a binary input.

Reading of content can also be performed remotely, for example from a IEC 61850 client. The value can also be presented as a measuring value on the local HMI graphical display.

12.2.8 Technical data

Table 372: CNTGGIO technical data

Function	Range or value	Accuracy
Counter value	0-100000	-
Max. count up speed	10 pulses/s (50% duty cycle)	-

12.3 Function description

Function description	IEC 61850 identification	IEC 60617 identification	ANSI/IEEE C37.2 device number
Limit counter	L4UFCNT		-

12.3.1 Limit counter L4UFCNT

12.3.2 Introduction

Limit counter (L4UFCNT) provides a settable counter with four independent limits where the number of positive and/or negative flanks on the input signal are counted against the setting values for limits. The output for each limit is activated when the counted value reaches that limit.

12.3.3 Principle of operation

Limit counter (L4UFCNT) counts the number of positive and/or negative flanks on the binary input signal depending on the function settings. L4UFCNT also checks if the accumulated value is equal or greater than any of its four settable limits. The four limit outputs will be activated relatively on reach of each limit and remain activated until the reset of the function. Moreover, the content of L4UFCNT is stored in flash memory and will not be lost at an auxiliary power interruption.

12.3.3.1 Design

Figure [Figure 1](#) illustrates the general logic diagram of the function.

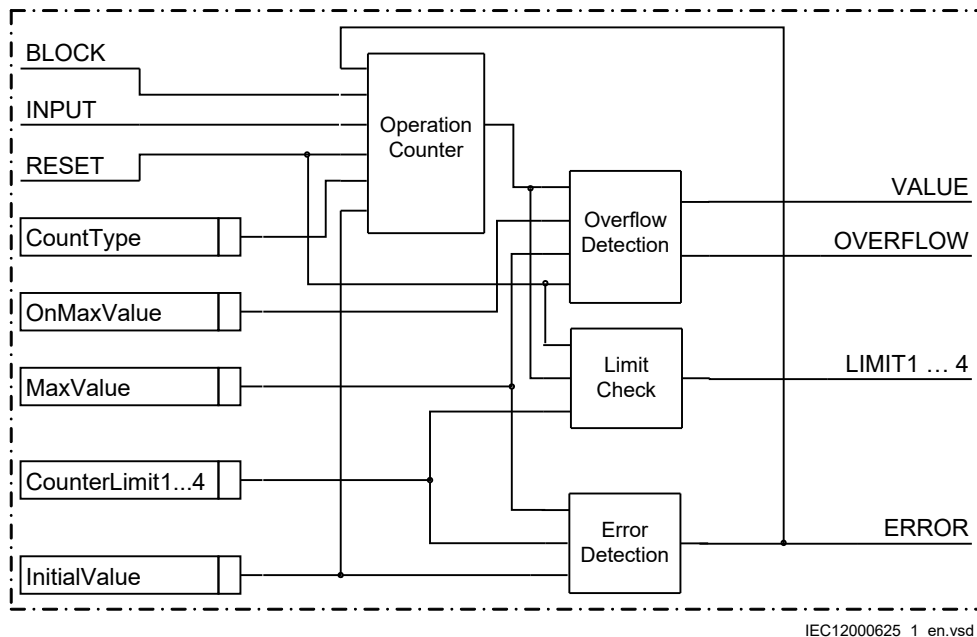

Figure 210: Logic diagram

The counter can be initialized to count from a settable non-zero value after reset of the function. The function has also a maximum counted value check. The three possibilities after reaching the maximum counted value are:

- Stops counting and activates a steady overflow indication for the next count
- Rolls over to zero and activates a steady overflow indication for the next count
- Rolls over to zero and activates a pulsed overflow indication for the next count

The pulsed overflow output lasts up to the first count after rolling over to zero, as illustrated in figure [Figure 2](#).

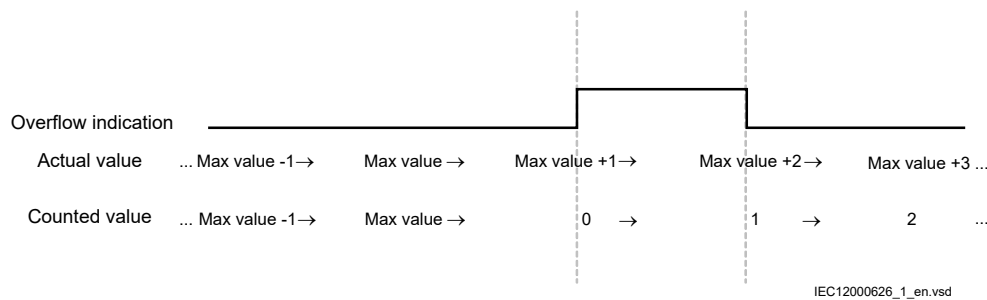

Figure 211: Overflow indication when OnMaxValue is set to rollover pulsed

The Error output is activated as an indicator of setting the counter limits and/or initial value setting(s) greater than the maximum value. The counter stops counting the input and all the outputs except the error output remains at zero state. The error condition remains until the correct settings for counter limits and/or initial value setting(s) are applied.

The function can be blocked through a block input. During the block time, input is not counted and outputs remain in their previous states. However, the counter can be initialized after reset of the function. In this case the outputs remain in their initial states until the release of the block input.

12.3.3.2 Reporting

The content of the counter can be read on the local HMI.

Reset of the counter can be performed from the local HMI or via a binary input.

Reading of content and resetting of the function can also be performed remotely, for example from a IEC 61850 client. The value can also be presented as a measurement on the local HMI graphical display.

12.3.4 Function block

L4UFCNT function block

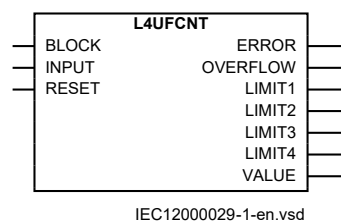

12.3.5 Signals

Table 373: L4UFCNT Input signals

Name	Type	Default	Description
BLOCK	BOOLEAN	0	Block of function
INPUT	BOOLEAN	0	Input for counter
RESET	BOOLEAN	0	Reset of function

Table 374: L4UFCNT Output signals

Name	Type	Description
ERROR	BOOLEAN	Error indication on counter limit and/or initial value settings
OVERFLOW	BOOLEAN	Overflow indication on count of greater than MaxValue
LIMIT1	BOOLEAN	Counted value is larger than or equal to CounterLimit1
LIMIT2	BOOLEAN	Counted value is larger than or equal to CounterLimit2
LIMIT3	BOOLEAN	Counted value is larger than or equal to CounterLimit3
LIMIT4	BOOLEAN	Counted value is larger than or equal to CounterLimit4
VALUE	INTEGER	Counted value

12.3.6 Settings

Table 375: L4UFCNT Group settings (basic)

Name	Values (Range)	Unit	Step	Default	Description
Operation	Off On	-	-	Off	Operation Off / On
CountType	Set Reset Both	-	-	Set	Select counting on positive and/or negative flanks
CounterLimit1	1 - 65535	-	1	100	Value of the first limit
CounterLimit2	1 - 65535	-	1	200	Value of the second limit
CounterLimit3	1 - 65535	-	1	300	Value of the third limit
CounterLimit4	1 - 65535	-	1	400	Value of the fourth limit
MaxValue	1 - 65535	-	1	500	Maximum count value
OnMaxValue	Stop Rollover Steady Rollover Pulsed	-	-	Stop	Select if counter stops or rolls over after reaching maxVal with steady or pulsed overflow flag
InitialValue	0 - 65535	-	1	0	Initial count value after reset of the function

12.3.7 Monitored data

Table 376: L4UFCNT Monitored data

Name	Type	Values (Range)	Unit	Description
VALUE	INTEGER	-	-	Counted value

12.3.8 Technical data

Table 377: L4UFCNTtechnical data

Function	Range or value	Accuracy
Counter value	0-65535	-
Max. count up speed	5-160 pulses/s	-

12.4 Disturbance report

12.4.1 Functionality

Complete and reliable information about disturbances in the primary and/or in the secondary system together with continuous event-logging is accomplished by the disturbance report functionality.

Disturbance report DRPRDRE, always included in the IED, acquires sampled data of all selected analog input and binary signals connected to the function block with a maximum of 40 analog and 96 binary signals.

The Disturbance report functionality is a common name for several functions:

- Event list
- Indications
- Event recorder
- Trip value recorder
- Disturbance recorder

The Disturbance report function is characterized by great flexibility regarding configuration, starting conditions, recording times, and large storage capacity.

A disturbance is defined as an activation of an input to the AnRADR or BnRBDR function blocks, which are set to trigger the disturbance recorder. All connected signals from start of pre-fault time to the end of post-fault time will be included in the recording.

Every disturbance report recording is saved in the IED in the standard Comtrade format as a reader file HDR, a configuration file CFG, and a data file DAT. The same applies to all events, which are continuously saved in a ring-buffer. The local HMI is used to get information about the recordings. The disturbance report files may be uploaded to PCM600 for further analysis using the disturbance handling tool.

12.4.2 Disturbance report DRPRDRE

12.4.2.1 Identification

Function description	IEC 61850 identification	IEC 60617 identification	ANSI/IEEE C37.2 device number
Disturbance report	DRPRDRE	-	-

12.4.2.2 Function block

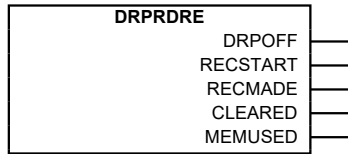

IEC09000346-1-en.vsd

Figure 212: DRPRDRE function block

12.4.2.3 Signals

Table 378: DRPRDRE Output signals

Name	Type	Description
DRPOFF	BOOLEAN	Disturbance report function turned off
RECSTART	BOOLEAN	Disturbance recording started
RECMAD	BOOLEAN	Disturbance recording made
CLEARED	BOOLEAN	All disturbances in the disturbance report cleared
MEMUSED	BOOLEAN	More than 80% of memory used

12.4.2.4 Settings

Table 379: DRPRDRE Non group settings (basic)

Name	Values (Range)	Unit	Step	Default	Description
Operation	Off On	-	-	Off	Operation Off/On
PreFaultRecT	0.05 - 9.90	s	0.01	0.10	Pre-fault recording time
PostFaultRecT	0.1 - 10.0	s	0.1	0.5	Post-fault recording time
TimeLimit	0.5 - 10.0	s	0.1	1.0	Fault recording time limit
PostRetrig	Off On	-	-	Off	Post-fault retrig enabled (On) or not (Off)
MaxNoStoreRec	10 - 100	-	1	100	Maximum number of stored disturbances
ZeroAngleRef	1 - 30	Ch	1	1	Trip value recorder, phasor reference channel
OpModeTest	Off On	-	-	Off	Operation mode during test mode

12.4.2.5 Monitored data

Table 380: DRPRDRE Monitored data

Name	Type	Values (Range)	Unit	Description
MemoryUsed	INTEGER	-	%	Memory usage (0-100%)
UnTrigStatCh1	BOOLEAN	-	-	Under level trig for analog channel 1 activated
OvTrigStatCh1	BOOLEAN	-	-	Over level trig for analog channel 1 activated
UnTrigStatCh2	BOOLEAN	-	-	Under level trig for analog channel 2 activated
OvTrigStatCh2	BOOLEAN	-	-	Over level trig for analog channel 2 activated
UnTrigStatCh3	BOOLEAN	-	-	Under level trig for analog channel 3 activated
OvTrigStatCh3	BOOLEAN	-	-	Over level trig for analog channel 3 activated
UnTrigStatCh4	BOOLEAN	-	-	Under level trig for analog channel 4 activated
OvTrigStatCh4	BOOLEAN	-	-	Over level trig for analog channel 4 activated
UnTrigStatCh5	BOOLEAN	-	-	Under level trig for analog channel 5 activated
OvTrigStatCh5	BOOLEAN	-	-	Over level trig for analog channel 5 activated
UnTrigStatCh6	BOOLEAN	-	-	Under level trig for analog channel 6 activated
OvTrigStatCh6	BOOLEAN	-	-	Over level trig for analog channel 6 activated
UnTrigStatCh7	BOOLEAN	-	-	Under level trig for analog channel 7 activated
OvTrigStatCh7	BOOLEAN	-	-	Over level trig for analog channel 7 activated
UnTrigStatCh8	BOOLEAN	-	-	Under level trig for analog channel 8 activated
OvTrigStatCh8	BOOLEAN	-	-	Over level trig for analog channel 8 activated
UnTrigStatCh9	BOOLEAN	-	-	Under level trig for analog channel 9 activated
OvTrigStatCh9	BOOLEAN	-	-	Over level trig for analog channel 9 activated
UnTrigStatCh10	BOOLEAN	-	-	Under level trig for analog channel 10 activated
OvTrigStatCh10	BOOLEAN	-	-	Over level trig for analog channel 10 activated
UnTrigStatCh11	BOOLEAN	-	-	Under level trig for analog channel 11 activated
OvTrigStatCh11	BOOLEAN	-	-	Over level trig for analog channel 11 activated
UnTrigStatCh12	BOOLEAN	-	-	Under level trig for analog channel 12 activated

Table continues on next page

Name	Type	Values (Range)	Unit	Description
OvTrigStatCh12	BOOLEAN	-	-	Over level trig for analog channel 12 activated
UnTrigStatCh13	BOOLEAN	-	-	Under level trig for analog channel 13 activated
OvTrigStatCh13	BOOLEAN	-	-	Over level trig for analog channel 13 activated
UnTrigStatCh14	BOOLEAN	-	-	Under level trig for analog channel 14 activated
OvTrigStatCh14	BOOLEAN	-	-	Over level trig for analog channel 14 activated
UnTrigStatCh15	BOOLEAN	-	-	Under level trig for analog channel 15 activated
OvTrigStatCh15	BOOLEAN	-	-	Over level trig for analog channel 15 activated
UnTrigStatCh16	BOOLEAN	-	-	Under level trig for analog channel 16 activated
OvTrigStatCh16	BOOLEAN	-	-	Over level trig for analog channel 16 activated
UnTrigStatCh17	BOOLEAN	-	-	Under level trig for analog channel 17 activated
OvTrigStatCh17	BOOLEAN	-	-	Over level trig for analog channel 17 activated
UnTrigStatCh18	BOOLEAN	-	-	Under level trig for analog channel 18 activated
OvTrigStatCh18	BOOLEAN	-	-	Over level trig for analog channel 18 activated
UnTrigStatCh19	BOOLEAN	-	-	Under level trig for analog channel 19 activated
OvTrigStatCh19	BOOLEAN	-	-	Over level trig for analog channel 19 activated
UnTrigStatCh20	BOOLEAN	-	-	Under level trig for analog channel 20 activated
OvTrigStatCh20	BOOLEAN	-	-	Over level trig for analog channel 20 activated
UnTrigStatCh21	BOOLEAN	-	-	Under level trig for analog channel 21 activated
OvTrigStatCh21	BOOLEAN	-	-	Over level trig for analog channel 21 activated
UnTrigStatCh22	BOOLEAN	-	-	Under level trig for analog channel 22 activated
OvTrigStatCh22	BOOLEAN	-	-	Over level trig for analog channel 22 activated
UnTrigStatCh23	BOOLEAN	-	-	Under level trig for analog channel 23 activated
OvTrigStatCh23	BOOLEAN	-	-	Over level trig for analog channel 23 activated
UnTrigStatCh24	BOOLEAN	-	-	Under level trig for analog channel 24 activated
OvTrigStatCh24	BOOLEAN	-	-	Over level trig for analog channel 24 activated
UnTrigStatCh25	BOOLEAN	-	-	Under level trig for analog channel 25 activated
Table continues on next page				

Name	Type	Values (Range)	Unit	Description
OvTrigStatCh25	BOOLEAN	-	-	Over level trig for analog channel 25 activated
UnTrigStatCh26	BOOLEAN	-	-	Under level trig for analog channel 26 activated
OvTrigStatCh26	BOOLEAN	-	-	Over level trig for analog channel 26 activated
UnTrigStatCh27	BOOLEAN	-	-	Under level trig for analog channel 27 activated
OvTrigStatCh27	BOOLEAN	-	-	Over level trig for analog channel 27 activated
UnTrigStatCh28	BOOLEAN	-	-	Under level trig for analog channel 28 activated
OvTrigStatCh28	BOOLEAN	-	-	Over level trig for analog channel 28 activated
UnTrigStatCh29	BOOLEAN	-	-	Under level trig for analog channel 29 activated
OvTrigStatCh29	BOOLEAN	-	-	Over level trig for analog channel 29 activated
UnTrigStatCh30	BOOLEAN	-	-	Under level trig for analog channel 30 activated
OvTrigStatCh30	BOOLEAN	-	-	Over level trig for analog channel 30 activated
UnTrigStatCh31	BOOLEAN	-	-	Under level trig for analog channel 31 activated
OvTrigStatCh31	BOOLEAN	-	-	Over level trig for analog channel 31 activated
UnTrigStatCh32	BOOLEAN	-	-	Under level trig for analog channel 32 activated
OvTrigStatCh32	BOOLEAN	-	-	Over level trig for analog channel 32 activated
UnTrigStatCh33	BOOLEAN	-	-	Under level trig for analog channel 33 activated
OvTrigStatCh33	BOOLEAN	-	-	Over level trig for analog channel 33 activated
UnTrigStatCh34	BOOLEAN	-	-	Under level trig for analog channel 34 activated
OvTrigStatCh34	BOOLEAN	-	-	Over level trig for analog channel 34 activated
UnTrigStatCh35	BOOLEAN	-	-	Under level trig for analog channel 35 activated
OvTrigStatCh35	BOOLEAN	-	-	Over level trig for analog channel 35 activated
UnTrigStatCh36	BOOLEAN	-	-	Under level trig for analog channel 36 activated
OvTrigStatCh36	BOOLEAN	-	-	Over level trig for analog channel 36 activated
UnTrigStatCh37	BOOLEAN	-	-	Under level trig for analog channel 37 activated
OvTrigStatCh37	BOOLEAN	-	-	Over level trig for analog channel 37 activated
UnTrigStatCh38	BOOLEAN	-	-	Under level trig for analog channel 38 activated
Table continues on next page				

Name	Type	Values (Range)	Unit	Description
OvTrigStatCh38	BOOLEAN	-	-	Over level trig for analog channel 38 activated
UnTrigStatCh39	BOOLEAN	-	-	Under level trig for analog channel 39 activated
OvTrigStatCh39	BOOLEAN	-	-	Over level trig for analog channel 39 activated
UnTrigStatCh40	BOOLEAN	-	-	Under level trig for analog channel 40 activated
OvTrigStatCh40	BOOLEAN	-	-	Over level trig for analog channel 40 activated
FaultNumber	INTEGER	-	-	Disturbance fault number

12.4.3 Analog input signals AxRADR

12.4.3.1 Identification

Function description	IEC 61850 identification	IEC 60617 identification	ANSI/IEEE C37.2 device number
Analog input signals	A1RADR	-	-
Analog input signals	A2RADR	-	-
Analog input signals	A3RADR	-	-

12.4.3.2 Function block

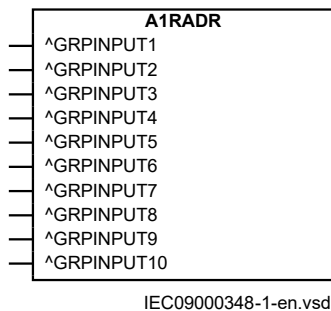

Figure 213: A1RADR function block, analog inputs, example for A1RADR, A2RADR and A3RADR

12.4.3.3 Signals

A1RADR - A3RADR Input signals

Tables for input signals for A1RADR, A2RADR and A3RADR are similar except for GRPINPUT number.

- A1RADR, GRPINPUT1 - GRPINPUT10
- A2RADR, GRPINPUT11 - GRPINPUT20
- A3RADR, GRPINPUT21 - GRPINPUT30

Table 381: A1RADR Input signals

Name	Type	Default	Description
GRPINPUT1	GROUP SIGNAL	-	Group signal for input 1
GRPINPUT2	GROUP SIGNAL	-	Group signal for input 2
GRPINPUT3	GROUP SIGNAL	-	Group signal for input 3
GRPINPUT4	GROUP SIGNAL	-	Group signal for input 4
GRPINPUT5	GROUP SIGNAL	-	Group signal for input 5
GRPINPUT6	GROUP SIGNAL	-	Group signal for input 6
GRPINPUT7	GROUP SIGNAL	-	Group signal for input 7
GRPINPUT8	GROUP SIGNAL	-	Group signal for input 8
GRPINPUT9	GROUP SIGNAL	-	Group signal for input 9
GRPINPUT10	GROUP SIGNAL	-	Group signal for input 10

12.4.3.4 Settings

A1RADR - A3RADR Settings

Setting tables for A1RADR, A2RADR and A3RADR are similar except for channel numbers.

- A1RADR, channel01 - channel10
- A2RADR, channel11 - channel20
- A3RADR, channel21 - channel30

Table 382: A1RADR Non group settings (basic)

Name	Values (Range)	Unit	Step	Default	Description
Operation01	Off On	-	-	Off	Operation On/Off
Operation02	Off On	-	-	Off	Operation On/Off
Operation03	Off On	-	-	Off	Operation On/Off
Operation04	Off On	-	-	Off	Operation On/Off
Operation05	Off On	-	-	Off	Operation On/Off
Operation06	Off On	-	-	Off	Operation On/Off
Operation07	Off On	-	-	Off	Operation On/Off
Operation08	Off On	-	-	Off	Operation On/Off

Table continues on next page

Name	Values (Range)	Unit	Step	Default	Description
Operation09	Off On	-	-	Off	Operation On/Off
Operation10	Off On	-	-	Off	Operation On/Off
FunType1	0 - 255	-	1	0	Function type for analog channel 1 (IEC-60870-5-103)
InfNo1	0 - 255	-	1	0	Information number for analog channel 1 (IEC-60870-5-103)
FunType2	0 - 255	-	1	0	Function type for analog channel 2 (IEC-60870-5-103)
InfNo2	0 - 255	-	1	0	Information number for analog channel 2 (IEC-60870-5-103)
FunType3	0 - 255	-	1	0	Function type for analog channel 3 (IEC-60870-5-103)
InfNo3	0 - 255	-	1	0	Information number for analog channel 3 (IEC-60870-5-103)
FunType4	0 - 255	-	1	0	Function type for analog channel 4 (IEC-60870-5-103)
InfNo4	0 - 255	-	1	0	Information number for analog channel 4 (IEC-60870-5-103)
FunType5	0 - 255	-	1	0	Function type for analog channel 5 (IEC-60870-5-103)
InfNo5	0 - 255	-	1	0	Information number for analog channel 5 (IEC-60870-5-103)
FunType6	0 - 255	-	1	0	Function type for analog channel 6 (IEC-60870-5-103)
InfNo6	0 - 255	-	1	0	Information number for analog channel 6 (IEC-60870-5-103)
FunType7	0 - 255	-	1	0	Function type for analog channel 7 (IEC-60870-5-103)
InfNo7	0 - 255	-	1	0	Information number for analog channel 7 (IEC-60870-5-103)
FunType8	0 - 255	-	1	0	Function type for analog channel 8 (IEC-60870-5-103)
InfNo8	0 - 255	-	1	0	Information number for analog channel 8 (IEC-60870-5-103)
FunType9	0 - 255	-	1	0	Function type for analog channel 9 (IEC-60870-5-103)
InfNo9	0 - 255	-	1	0	Information number for analog channel 9 (IEC-60870-5-103)
FunType10	0 - 255	-	1	0	Function type for analog channel 10 (IEC-60870-5-103)
InfNo10	0 - 255	-	1	0	Information number for analog channel10 (IEC-60870-5-103)

Table 383: A1RADR Non group settings (advanced)

Name	Values (Range)	Unit	Step	Default	Description
NomValue01	0.0 - 999999.9	-	0.1	0.0	Nominal value for analog channel 1
UnderTrigOp01	Off On	-	-	Off	Use under level trigger for analog channel 1 (on) or not (off)
UnderTrigLe01	0 - 200	%	1	50	Under trigger level for analog channel 1 in % of signal
OverTrigOp01	Off On	-	-	Off	Use over level trigger for analog channel 1 (on) or not (off)
OverTrigLe01	0 - 5000	%	1	200	Over trigger level for analog channel 1 in % of signal
NomValue02	0.0 - 999999.9	-	0.1	0.0	Nominal value for analog channel 2
UnderTrigOp02	Off On	-	-	Off	Use under level trigger for analog channel 2 (on) or not (off)
UnderTrigLe02	0 - 200	%	1	50	Under trigger level for analog channel 2 in % of signal
OverTrigOp02	Off On	-	-	Off	Use over level trigger for analog channel 2 (on) or not (off)
OverTrigLe02	0 - 5000	%	1	200	Over trigger level for analog channel 2 in % of signal
NomValue03	0.0 - 999999.9	-	0.1	0.0	Nominal value for analog channel 3
UnderTrigOp03	Off On	-	-	Off	Use under level trigger for analog channel 3 (on) or not (off)
UnderTrigLe03	0 - 200	%	1	50	Under trigger level for analog channel 3 in % of signal
OverTrigOp03	Off On	-	-	Off	Use over level trigger for analog channel 3 (on) or not (off)
OverTrigLe03	0 - 5000	%	1	200	Overtrigger level for analog channel 3 in % of signal
NomValue04	0.0 - 999999.9	-	0.1	0.0	Nominal value for analog channel 4
UnderTrigOp04	Off On	-	-	Off	Use under level trigger for analog channel 4 (on) or not (off)
UnderTrigLe04	0 - 200	%	1	50	Under trigger level for analog channel 4 in % of signal
OverTrigOp04	Off On	-	-	Off	Use over level trigger for analog channel 4 (on) or not (off)
OverTrigLe04	0 - 5000	%	1	200	Over trigger level for analog channel 4 in % of signal
NomValue05	0.0 - 999999.9	-	0.1	0.0	Nominal value for analog channel 5
UnderTrigOp05	Off On	-	-	Off	Use under level trigger for analog channel 5 (on) or not (off)
UnderTrigLe05	0 - 200	%	1	50	Under trigger level for analog channel 5 in % of signal
OverTrigOp05	Off On	-	-	Off	Use over level trigger for analog channel 5 (on) or not (off)
OverTrigLe05	0 - 5000	%	1	200	Over trigger level for analog channel 5 in % of signal
NomValue06	0.0 - 999999.9	-	0.1	0.0	Nominal value for analog channel 6
UnderTrigOp06	Off On	-	-	Off	Use under level trigger for analog channel 6 (on) or not (off)
UnderTrigLe06	0 - 200	%	1	50	Under trigger level for analog channel 6 in % of signal

Table continues on next page

Name	Values (Range)	Unit	Step	Default	Description
OverTrigOp06	Off On	-	-	Off	Use over level trigger for analog channel 6 (on) or not (off)
OverTrigLe06	0 - 5000	%	1	200	Over trigger level for analog channel 6 in % of signal
NomValue07	0.0 - 999999.9	-	0.1	0.0	Nominal value for analog channel 7
UnderTrigOp07	Off On	-	-	Off	Use under level trigger for analog channel 7 (on) or not (off)
UnderTrigLe07	0 - 200	%	1	50	Under trigger level for analog channel 7 in % of signal
OverTrigOp07	Off On	-	-	Off	Use over level trigger for analog channel 7 (on) or not (off)
OverTrigLe07	0 - 5000	%	1	200	Over trigger level for analog channel 7 in % of signal
NomValue08	0.0 - 999999.9	-	0.1	0.0	Nominal value for analog channel 8
UnderTrigOp08	Off On	-	-	Off	Use under level trigger for analog channel 8 (on) or not (off)
UnderTrigLe08	0 - 200	%	1	50	Under trigger level for analog channel 8 in % of signal
OverTrigOp08	Off On	-	-	Off	Use over level trigger for analog channel 8 (on) or not (off)
OverTrigLe08	0 - 5000	%	1	200	Over trigger level for analog channel 8 in % of signal
NomValue09	0.0 - 999999.9	-	0.1	0.0	Nominal value for analog channel 9
UnderTrigOp09	Off On	-	-	Off	Use under level trigger for analog channel 9 (on) or not (off)
UnderTrigLe09	0 - 200	%	1	50	Under trigger level for analog channel 9 in % of signal
OverTrigOp09	Off On	-	-	Off	Use over level trigger for analog channel 9 (on) or not (off)
OverTrigLe09	0 - 5000	%	1	200	Over trigger level for analog channel 9 in % of signal
NomValue10	0.0 - 999999.9	-	0.1	0.0	Nominal value for analog channel 10
UnderTrigOp10	Off On	-	-	Off	Use under level trigger for analog channel 10 (on) or not (off)
UnderTrigLe10	0 - 200	%	1	50	Under trigger level for analog channel 10 in % of signal
OverTrigOp10	Off On	-	-	Off	Use over level trigger for analog channel 10 (on) or not (off)
OverTrigLe10	0 - 5000	%	1	200	Over trigger level for analog channel 10 in % of signal

12.4.4 Analog input signals A4RADR

12.4.4.1 Identification

Function description	IEC 61850 identification	IEC 60617 identification	ANSI/IEEE C37.2 device number
Analog input signals	A4RADR	-	-

12.4.4.2 Function block

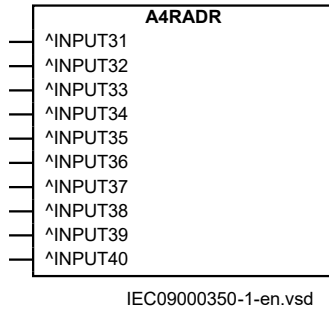

Figure 214: A4RADR function block, derived analog inputs



Channels 31-40 are not shown in LHMI. They are used for internally calculated analog signals.

12.4.4.3 Signals

Table 384: A4RADR Input signals

Name	Type	Default	Description
INPUT31	REAL	0	Analog channel 31
INPUT32	REAL	0	Analog channel 32
INPUT33	REAL	0	Analog channel 33
INPUT34	REAL	0	Analog channel 34
INPUT35	REAL	0	Analog channel 35
INPUT36	REAL	0	Analog channel 36
INPUT37	REAL	0	Analog channel 37
INPUT38	REAL	0	Analog channel 38
INPUT39	REAL	0	Analog channel 39
INPUT40	REAL	0	Analog channel 40

12.4.4.4 Settings

Table 385: A4RADR Non group settings (basic)

Name	Values (Range)	Unit	Step	Default	Description
Operation31	Off On	-	-	Off	Operation On/off
Operation32	Off On	-	-	Off	Operation On/off
Operation33	Off On	-	-	Off	Operation On/off
Operation34	Off On	-	-	Off	Operation On/off

Table continues on next page

Name	Values (Range)	Unit	Step	Default	Description
Operation35	Off On	-	-	Off	Operation On/off
Operation36	Off On	-	-	Off	Operation On/off
Operation37	Off On	-	-	Off	Operation On/off
Operation38	Off On	-	-	Off	Operation On/off
Operation39	Off On	-	-	Off	Operation On/off
Operation40	Off On	-	-	Off	Operation On/off
FunType31	0 - 255	-	1	0	Function type for analog channel 31 (IEC-60870-5-103)
InfNo31	0 - 255	-	1	0	Information number for analog channel 31 (IEC-60870-5-103)
FunType32	0 - 255	-	1	0	Function type for analog channel 32 (IEC-60870-5-103)
InfNo32	0 - 255	-	1	0	Information number for analog channel 32 (IEC-60870-5-103)
FunType33	0 - 255	-	1	0	Function type for analog channel 33 (IEC-60870-5-103)
InfNo33	0 - 255	-	1	0	Information number for analog channel 33 (IEC-60870-5-103)
FunType34	0 - 255	-	1	0	Function type for analog channel 34 (IEC-60870-5-103)
InfNo34	0 - 255	-	1	0	Information number for analog channel 34 (IEC-60870-5-103)
FunType35	0 - 255	-	1	0	Function type for analog channel 35 (IEC-60870-5-103)
InfNo35	0 - 255	-	1	0	Information number for analog channel 35 (IEC-60870-5-103)
FunType36	0 - 255	-	1	0	Function type for analog channel 36 (IEC-60870-5-103)
InfNo36	0 - 255	-	1	0	Information number for analog channel 36 (IEC-60870-5-103)
FunType37	0 - 255	-	1	0	Function type for analog channel 37 (IEC-60870-5-103)
InfNo37	0 - 255	-	1	0	Information number for analog channel 37 (IEC-60870-5-103)
FunType38	0 - 255	-	1	0	Function type for analog channel 38 (IEC-60870-5-103)
InfNo38	0 - 255	-	1	0	Information number for analog channel 38 (IEC-60870-5-103)
FunType39	0 - 255	-	1	0	Function type for analog channel 39 (IEC-60870-5-103)
InfNo39	0 - 255	-	1	0	Information number for analog channel 39 (IEC-60870-5-103)
FunType40	0 - 255	-	1	0	Function type for analog channel 40 (IEC-60870-5-103)
InfNo40	0 - 255	-	1	0	Information number for analog channel 40 (IEC-60870-5-103)

Table 386: A4RADR Non group settings (advanced)

Name	Values (Range)	Unit	Step	Default	Description
NomValue31	0.0 - 999999.9	-	0.1	0.0	Nominal value for analog channel 31
UnderTrigOp31	Off On	-	-	Off	Use under level trigger for analog channel 31 (on) or not (off)
UnderTrigLe31	0 - 200	%	1	50	Under trigger level for analog channel 31 in % of signal
OverTrigOp31	Off On	-	-	Off	Use over level trigger for analog channel 31 (on) or not (off)
OverTrigLe31	0 - 5000	%	1	200	Over trigger level for analog channel 31 in % of signal
NomValue32	0.0 - 999999.9	-	0.1	0.0	Nominal value for analog channel 32
UnderTrigOp32	Off On	-	-	Off	Use under level trigger for analog channel 32 (on) or not (off)
UnderTrigLe32	0 - 200	%	1	50	Under trigger level for analog channel 32 in % of signal
OverTrigOp32	Off On	-	-	Off	Use over level trigger for analog channel 32 (on) or not (off)
OverTrigLe32	0 - 5000	%	1	200	Over trigger level for analog channel 32 in % of signal
NomValue33	0.0 - 999999.9	-	0.1	0.0	Nominal value for analog channel 33
UnderTrigOp33	Off On	-	-	Off	Use under level trigger for analog channel 33 (on) or not (off)
UnderTrigLe33	0 - 200	%	1	50	Under trigger level for analog channel 33 in % of signal
OverTrigOp33	Off On	-	-	Off	Use over level trigger for analog channel 33 (on) or not (off)
OverTrigLe33	0 - 5000	%	1	200	Overtrigger level for analog channel 33 in % of signal
NomValue34	0.0 - 999999.9	-	0.1	0.0	Nominal value for analog channel 34
UnderTrigOp34	Off On	-	-	Off	Use under level trigger for analog channel 34 (on) or not (off)
UnderTrigLe34	0 - 200	%	1	50	Under trigger level for analog channel 34 in % of signal
OverTrigOp34	Off On	-	-	Off	Use over level trigger for analog channel 34 (on) or not (off)
OverTrigLe34	0 - 5000	%	1	200	Over trigger level for analog channel 34 in % of signal
NomValue35	0.0 - 999999.9	-	0.1	0.0	Nominal value for analog channel 35
UnderTrigOp35	Off On	-	-	Off	Use under level trigger for analog channel 35 (on) or not (off)
UnderTrigLe35	0 - 200	%	1	50	Under trigger level for analog channel 35 in % of signal
OverTrigOp35	Off On	-	-	Off	Use over level trigger for analog channel 35 (on) or not (off)
OverTrigLe35	0 - 5000	%	1	200	Over trigger level for analog channel 35 in % of signal
NomValue36	0.0 - 999999.9	-	0.1	0.0	Nominal value for analog channel 36
UnderTrigOp36	Off On	-	-	Off	Use under level trigger for analog channel 36 (on) or not (off)
UnderTrigLe36	0 - 200	%	1	50	Under trigger level for analog channel 36 in % of signal

Table continues on next page

Name	Values (Range)	Unit	Step	Default	Description
OverTrigOp36	Off On	-	-	Off	Use over level trigger for analog channel 36 (on) or not (off)
OverTrigLe36	0 - 5000	%	1	200	Over trigger level for analog channel 36 in % of signal
NomValue37	0.0 - 999999.9	-	0.1	0.0	Nominal value for analog channel 37
UnderTrigOp37	Off On	-	-	Off	Use under level trigger for analog channel 37 (on) or not (off)
UnderTrigLe37	0 - 200	%	1	50	Under trigger level for analog channel 37 in % of signal
OverTrigOp37	Off On	-	-	Off	Use over level trigger for analog channel 37 (on) or not (off)
OverTrigLe37	0 - 5000	%	1	200	Over trigger level for analog channel 37 in % of signal
NomValue38	0.0 - 999999.9	-	0.1	0.0	Nominal value for analog channel 38
UnderTrigOp38	Off On	-	-	Off	Use under level trigger for analog channel 38 (on) or not (off)
UnderTrigLe38	0 - 200	%	1	50	Under trigger level for analog channel 38 in % of signal
OverTrigOp38	Off On	-	-	Off	Use over level trigger for analog channel 38 (on) or not (off)
OverTrigLe38	0 - 5000	%	1	200	Over trigger level for analog channel 38 in % of signal
NomValue39	0.0 - 999999.9	-	0.1	0.0	Nominal value for analog channel 39
UnderTrigOp39	Off On	-	-	Off	Use under level trigger for analog channel 39 (on) or not (off)
UnderTrigLe39	0 - 200	%	1	50	Under trigger level for analog channel 39 in % of signal
OverTrigOp39	Off On	-	-	Off	Use over level trigger for analog channel 39 (on) or not (off)
OverTrigLe39	0 - 5000	%	1	200	Over trigger level for analog channel 39 in % of signal
NomValue40	0.0 - 999999.9	-	0.1	0.0	Nominal value for analog channel 40
UnderTrigOp40	Off On	-	-	Off	Use under level trigger for analog channel 40 (on) or not (off)
UnderTrigLe40	0 - 200	%	1	50	Under trigger level for analog channel 40 in % of signal
OverTrigOp40	Off On	-	-	Off	Use over level trigger for analog channel 40 (on) or not (off)
OverTrigLe40	0 - 5000	%	1	200	Over trigger level for analog channel 40 in % of signal

12.4.5 Binary input signals BxRBDR

12.4.5.1 Identification

Function description	IEC 61850 identification	IEC 60617 identification	ANSI/IEEE C37.2 device number
Binary input signals	B1RBDR	-	-
Binary input signals	B2RBDR	-	-
Binary input signals	B3RBDR	-	-
Binary input signals	B4RBDR	-	-
Binary input signals	B5RBDR	-	-
Binary input signals	B6RBDR	-	-

12.4.5.2 Function block

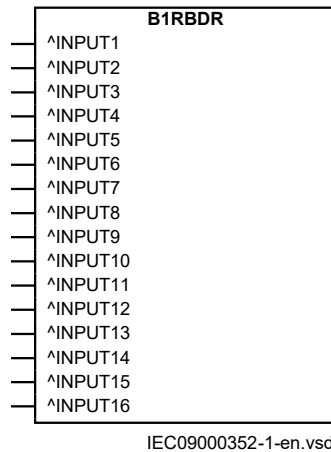

Figure 215: B1RBDR function block, binary inputs, example for B1RBDR - B6RBDR

12.4.5.3 Signals

B1RBDR - B6RBDR Input signals

Tables for input signals for B1RBDR - B6RBDR are all similar except for INPUT and description number.

- B1RBDR, INPUT1 - INPUT16
- B2RBDR, INPUT17 - INPUT32
- B3RBDR, INPUT33 - INPUT48
- B4RBDR, INPUT49 - INPUT64
- B5RBDR, INPUT65 - INPUT80
- B6RBDR, INPUT81 - INPUT96

Table 387: B1RBDR Input signals

Name	Type	Default	Description
INPUT1	BOOLEAN	0	Binary channel 1
INPUT2	BOOLEAN	0	Binary channel 2
INPUT3	BOOLEAN	0	Binary channel 3
INPUT4	BOOLEAN	0	Binary channel 4
INPUT5	BOOLEAN	0	Binary channel 5
INPUT6	BOOLEAN	0	Binary channel 6
INPUT7	BOOLEAN	0	Binary channel 7
INPUT8	BOOLEAN	0	Binary channel 8
INPUT9	BOOLEAN	0	Binary channel 9
INPUT10	BOOLEAN	0	Binary channel 10
INPUT11	BOOLEAN	0	Binary channel 11
INPUT12	BOOLEAN	0	Binary channel 12
INPUT13	BOOLEAN	0	Binary channel 13
INPUT14	BOOLEAN	0	Binary channel 14
INPUT15	BOOLEAN	0	Binary channel 15
INPUT16	BOOLEAN	0	Binary channel 16

12.4.5.4 Settings

B1RBDR - B6RBDR Settings

Setting tables for B1RBDR - B6RBDR are all similar except for binary channel and description numbers.

- B1RBDR, channel1 - channel16
- B2RBDR, channel17 - channel32
- B3RBDR, channel33 - channel48
- B4RBDR, channel49 - channel64
- B5RBDR, channel65 - channel80
- B6RBDR, channel81 - channel96

Table 388: B1RBDR Non group settings (basic)

Name	Values (Range)	Unit	Step	Default	Description
TrigDR01	Off On	-	-	Off	Trigger operation On/Off
SetLED01	Off Start Trip Start and Trip	-	-	Off	Set LED on HMI for binary channel 1
TrigDR02	Off On	-	-	Off	Trigger operation On/Off
SetLED02	Off Start Trip Start and Trip	-	-	Off	Set LED on HMI for binary channel 2
TrigDR03	Off On	-	-	Off	Trigger operation On/Off

Table continues on next page

Name	Values (Range)	Unit	Step	Default	Description
SetLED03	Off Start Trip Start and Trip	-	-	Off	Set LED on HMI for binary channel 3
TrigDR04	Off On	-	-	Off	Trigger operation On/Off
SetLED04	Off Start Trip Start and Trip	-	-	Off	Set LED on HMI for binary channel 4
TrigDR05	Off On	-	-	Off	Trigger operation On/Off
SetLED05	Off Start Trip Start and Trip	-	-	Off	Set LED on HMI for binary channel 5
TrigDR06	Off On	-	-	Off	Trigger operation On/Off
SetLED06	Off Start Trip Start and Trip	-	-	Off	Set LED on HMI for binary channel 6
TrigDR07	Off On	-	-	Off	Trigger operation On/Off
SetLED07	Off Start Trip Start and Trip	-	-	Off	Set LED on HMI for binary channel 7
TrigDR08	Off On	-	-	Off	Trigger operation On/Off
SetLED08	Off Start Trip Start and Trip	-	-	Off	Set LED on HMI for binary channel 8
TrigDR09	Off On	-	-	Off	Trigger operation On/Off
SetLED09	Off Start Trip Start and Trip	-	-	Off	Set LED on HMI for binary channel 9
TrigDR10	Off On	-	-	Off	Trigger operation On/Off
SetLED10	Off Start Trip Start and Trip	-	-	Off	Set LED on HMI for binary channel 10
TrigDR11	Off On	-	-	Off	Trigger operation On/Off
SetLED11	Off Start Trip Start and Trip	-	-	Off	Set LED on HMI for binary channel 11
TrigDR12	Off On	-	-	Off	Trigger operation On/Off

Table continues on next page

Name	Values (Range)	Unit	Step	Default	Description
SetLED12	Off Start Trip Start and Trip	-	-	Off	Set LED on HMI for binary channel 12
TrigDR13	Off On	-	-	Off	Trigger operation On/Off
SetLED13	Off Start Trip Start and Trip	-	-	Off	Set LED on HMI for binary channel 13
TrigDR14	Off On	-	-	Off	Trigger operation On/Off
SetLED14	Off Start Trip Start and Trip	-	-	Off	Set LED on HMI for binary channel 14
TrigDR15	Off On	-	-	Off	Trigger operation On/Off
SetLED15	Off Start Trip Start and Trip	-	-	Off	Set LED on HMI for binary channel 15
TrigDR16	Off On	-	-	Off	Trigger operation On/Off
SetLED16	Off Start Trip Start and Trip	-	-	Off	Set LED on HMI for binary channel 16
FunType1	0 - 255	-	1	0	Function type for binary channel 1 (IEC -60870-5-103)
InfNo1	0 - 255	-	1	0	Information number for binary channel 1 (IEC -60870-5-103)
FunType2	0 - 255	-	1	0	Function type for binary channel 2 (IEC -60870-5-103)
InfNo2	0 - 255	-	1	0	Information number for binary channel 2 (IEC -60870-5-103)
FunType3	0 - 255	-	1	0	Function type for binary channel 3 (IEC -60870-5-103)
InfNo3	0 - 255	-	1	0	Information number for binary channel 3 (IEC -60870-5-103)
FunType4	0 - 255	-	1	0	Function type for binary channel 4 (IEC -60870-5-103)
InfNo4	0 - 255	-	1	0	Information number for binary channel 4 (IEC -60870-5-103)
FunType5	0 - 255	-	1	0	Function type for binary channel 5 (IEC -60870-5-103)
InfNo5	0 - 255	-	1	0	Information number for binary channel 5 (IEC -60870-5-103)
FunType6	0 - 255	-	1	0	Function type for binary channel 6 (IEC -60870-5-103)
InfNo6	0 - 255	-	1	0	Information number for binary channel 6 (IEC -60870-5-103)
FunType7	0 - 255	-	1	0	Function type for binary channel 7 (IEC -60870-5-103)

Table continues on next page

Name	Values (Range)	Unit	Step	Default	Description
InfNo7	0 - 255	-	1	0	Information number for binary channel 7 (IEC -60870-5-103)
FunType8	0 - 255	-	1	0	Function type for binary channel 8 (IEC -60870-5-103)
InfNo8	0 - 255	-	1	0	Information number for binary channel 8 (IEC -60870-5-103)
FunType9	0 - 255	-	1	0	Function type for binary channel 9 (IEC -60870-5-103)
InfNo9	0 - 255	-	1	0	Information number for binary channel 9 (IEC -60870-5-103)
FunType10	0 - 255	-	1	0	Function type for binary channel 10 (IEC -60870-5-103)
InfNo10	0 - 255	-	1	0	Information number for binary channel 10 (IEC -60870-5-103)
FunType11	0 - 255	-	1	0	Function type for binary channel 11 (IEC -60870-5-103)
InfNo11	0 - 255	-	1	0	Information number for binary channel 11 (IEC -60870-5-103)
FunType12	0 - 255	-	1	0	Function type for binary channel 12 (IEC -60870-5-103)
InfNo12	0 - 255	-	1	0	Information number for binary channel 12 (IEC -60870-5-103)
FunType13	0 - 255	-	1	0	Function type for binary channel 13 (IEC -60870-5-103)
InfNo13	0 - 255	-	1	0	Information number for binary channel 13 (IEC -60870-5-103)
FunType14	0 - 255	-	1	0	Function type for binary channel 14 (IEC -60870-5-103)
InfNo14	0 - 255	-	1	0	Information number for binary channel 14 (IEC -60870-5-103)
FunType15	0 - 255	-	1	0	Function type for binary channel 15 (IEC -60870-5-103)
InfNo15	0 - 255	-	1	0	Information number for binary channel 15 (IEC -60870-5-103)
FunType16	0 - 255	-	1	0	Function type for binary channel 16 (IEC -60870-5-103)
InfNo16	0 - 255	-	1	0	Information number for binary channel 16 (IEC -60870-5-103)

Table 389: B1RBDR Non group settings (advanced)

Name	Values (Range)	Unit	Step	Default	Description
TrigLevel01	Trig on 0 Trig on 1	-	-	Trig on 1	Trigger on positive (1) or negative (0) slope for binary input 1
IndicationMa01	Hide Show	-	-	Hide	Indication mask for binary channel 1
TrigLevel02	Trig on 0 Trig on 1	-	-	Trig on 1	Trigger on positive (1) or negative (0) slope for binary input 2
IndicationMa02	Hide Show	-	-	Hide	Indication mask for binary channel 2
TrigLevel03	Trig on 0 Trig on 1	-	-	Trig on 1	Trigger on positive (1) or negative (0) slope for binary input 3

Table continues on next page

Name	Values (Range)	Unit	Step	Default	Description
IndicationMa03	Hide Show	-	-	Hide	Indication mask for binary channel 3
TrigLevel04	Trig on 0 Trig on 1	-	-	Trig on 1	Trigger on positive (1) or negative (0) slope for binary input 4
IndicationMa04	Hide Show	-	-	Hide	Indication mask for binary channel 4
TrigLevel05	Trig on 0 Trig on 1	-	-	Trig on 1	Trigger on positive (1) or negative (0) slope for binary input 5
IndicationMa05	Hide Show	-	-	Hide	Indication mask for binary channel 5
TrigLevel06	Trig on 0 Trig on 1	-	-	Trig on 1	Trigger on positive (1) or negative (0) slope for binary input 6
IndicationMa06	Hide Show	-	-	Hide	Indication mask for binary channel 6
TrigLevel07	Trig on 0 Trig on 1	-	-	Trig on 1	Trigger on positive (1) or negative (0) slope for binary input 7
IndicationMa07	Hide Show	-	-	Hide	Indication mask for binary channel 7
TrigLevel08	Trig on 0 Trig on 1	-	-	Trig on 1	Trigger on positive (1) or negative (0) slope for binary input 8
IndicationMa08	Hide Show	-	-	Hide	Indication mask for binary channel 8
TrigLevel09	Trig on 0 Trig on 1	-	-	Trig on 1	Trigger on positive (1) or negative (0) slope for binary input 9
IndicationMa09	Hide Show	-	-	Hide	Indication mask for binary channel 9
TrigLevel10	Trig on 0 Trig on 1	-	-	Trig on 1	Trigger on positive (1) or negative (0) slope for binary input 10
IndicationMa10	Hide Show	-	-	Hide	Indication mask for binary channel 10
TrigLevel11	Trig on 0 Trig on 1	-	-	Trig on 1	Trigger on positive (1) or negative (0) slope for binary input 11
IndicationMa11	Hide Show	-	-	Hide	Indication mask for binary channel 11
TrigLevel12	Trig on 0 Trig on 1	-	-	Trig on 1	Trigger on positive (1) or negative (0) slope for binary input 12
IndicationMa12	Hide Show	-	-	Hide	Indication mask for binary channel 12
TrigLevel13	Trig on 0 Trig on 1	-	-	Trig on 1	Trigger on positive (1) or negative (0) slope for binary input 13
IndicationMa13	Hide Show	-	-	Hide	Indication mask for binary channel 13
TrigLevel14	Trig on 0 Trig on 1	-	-	Trig on 1	Trigger on positive (1) or negative (0) slope for binary input 14
IndicationMa14	Hide Show	-	-	Hide	Indication mask for binary channel 14
TrigLevel15	Trig on 0 Trig on 1	-	-	Trig on 1	Trigger on positive (1) or negative (0) slope for binary input 15
IndicationMa15	Hide Show	-	-	Hide	Indication mask for binary channel 15
TrigLevel16	Trig on 0 Trig on 1	-	-	Trig on 1	Trigger on positive (1) or negative (0) slope for binary input 16
IndicationMa16	Hide Show	-	-	Hide	Indication mask for binary channel 16

12.4.6 Operation principle

Disturbance report DRPRDRE is a common name for several functions to supply the operator, analysis engineer, and so on, with sufficient information about events in the system.

The functions included in the disturbance report are:

- Event list
- Indications
- Event recorder
- Trip value recorder
- Disturbance recorder

Figure 216 shows the relations between Disturbance Report, included functions and function blocks. Event list, Event recorder and Indications uses information from the binary input function blocks (BxRBDR). Trip value recorder uses analog information from the analog input function blocks (AxRADR). Disturbance recorder DRPRDRE acquires information from both AxRADR and BxRBDR.

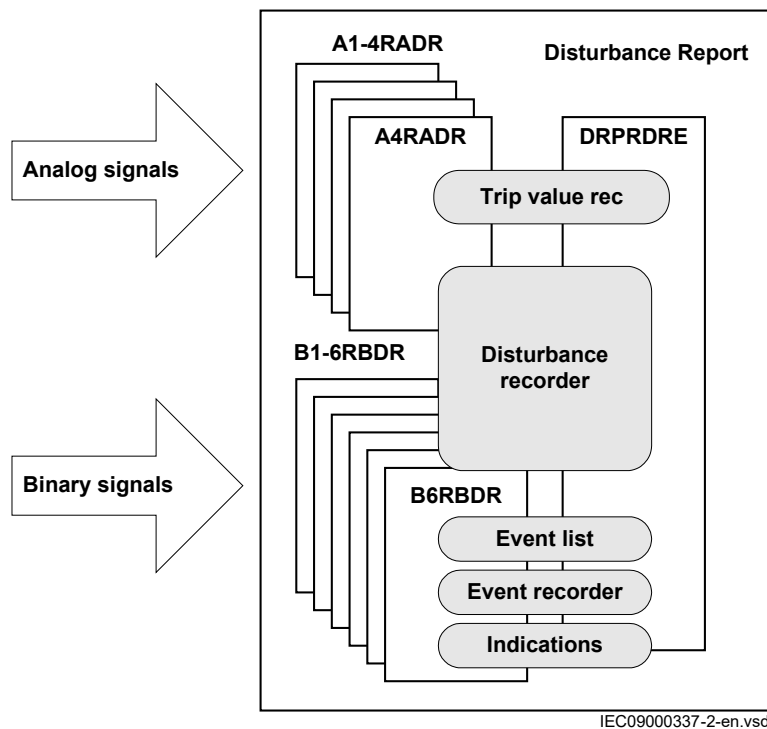

Figure 216: Disturbance report functions and related function blocks

The whole disturbance report can contain information for a number of recordings, each with the data coming from all the parts mentioned above. The event list function is working continuously, independent of disturbance triggering, recording time, and so on. All information in the disturbance report is stored in non-volatile flash memories. This implies that no information is lost in case of loss of auxiliary power. Each report will get an identification number in the interval from 0-999.

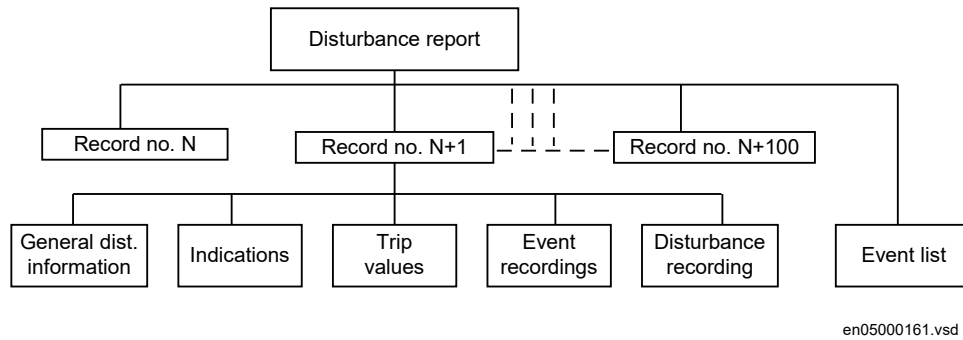

Figure 217: Disturbance report structure

Up to 100 disturbance reports can be stored. If a new disturbance is to be recorded when the memory is full, the oldest disturbance report is overwritten by the new one. The total recording capacity for the disturbance recorder is depending of sampling frequency, number of analog and binary channels and recording time. In a 50 Hz system it is possible to record 100 where the maximum recording time is 3.4 seconds. The memory limit does not affect the rest of the disturbance report (Event list, Event recorder, Indications and Trip value recorder).



The maximum number of recordings depend on each recordings total recording time. Long recording time will reduce the number of recordings to less than 100.



The IED flash disk should NOT be used to store any user files. This might cause disturbance recordings to be deleted due to lack of disk space.

12.4.6.1 Disturbance information

Date and time of the disturbance, the indications, events, fault location and the trip values are available on the local HMI. To acquire a complete disturbance report the user must use a PC and - either the PCM600 Disturbance handling tool - or a FTP or MMS (over 61850) client. The PC can be connected to the IED front, rear or remotely via the station bus (Ethernet ports).

12.4.6.2 Indications

Indications is a list of signals that were activated during the total recording time of the disturbance (not time-tagged), see Indication section for detailed information.

12.4.6.3 Event recorder

The event recorder may contain a list of up to 150 time-tagged events, which have occurred during the disturbance. The information is available via the local HMI or PCM600, see Event recorder section for detailed information.

12.4.6.4 Event list

The event list may contain a list of totally 1000 time-tagged events. The list information is continuously updated when selected binary signals change state. The oldest data is overwritten. The logged signals may be presented via local HMI or PCM600, see Event list section for detailed information.

12.4.6.5 Trip value recorder

The recorded trip values include phasors of selected analog signals before the fault and during the fault, see Trip value recorder section for detailed information.

12.4.6.6 Disturbance recorder

Disturbance recorder records analog and binary signal data before, during and after the fault, see Disturbance recorder section for detailed information.

12.4.6.7 Time tagging

The IED has a built-in real-time calendar and clock. This function is used for all time tagging within the disturbance report

12.4.6.8 Recording times

Disturbance report DRPRDRE records information about a disturbance during a settable time frame. The recording times are valid for the whole disturbance report. Disturbance recorder, event recorder and indication function register disturbance data and events during $t_{Recording}$, the total recording time.

The total recording time, $t_{Recording}$, of a recorded disturbance is:

$$t_{Recording} = \begin{matrix} PreFaultRecT + t_{Fault} + PostFaultRecT \text{ or } \\ PreFaultRecT + TimeLimit, \text{ depending on} \\ \text{which criterion stops the current disturbance recording} \end{matrix}$$

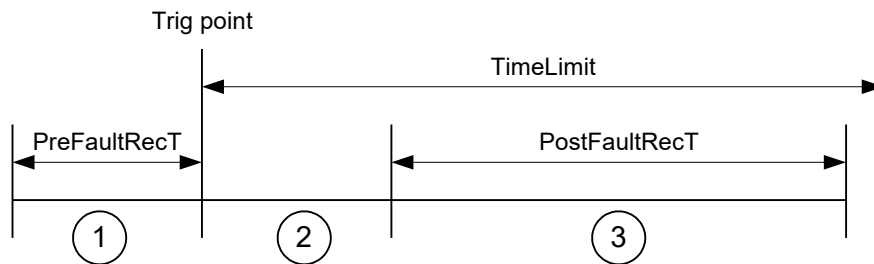

en05000487.vsd

Figure 218: The recording times definition

- PreFaultRecT, 1 Pre-fault or pre-trigger recording time. The time before the fault including the operate time of the trigger. Use the setting *PreFaultRecT* to set this time.
- tFault, 2 Fault time of the recording. The fault time cannot be set. It continues as long as any valid trigger condition, binary or analog, persists (unless limited by *TimeLimit* the limit time).
- PostFaultRecT, 3 Post fault recording time. The time the disturbance recording continues after all activated triggers are reset. Use the setting *PostFaultRecT* to set this time.
- TimeLimit Limit time. The maximum allowed recording time after the disturbance recording was triggered. The limit time is used to eliminate the consequences of a trigger that does not reset within a reasonable time interval. It limits the maximum recording time of a recording and prevents subsequent overwriting of already stored disturbances. Use the setting *TimeLimit* to set this time.

12.4.6.9 Analog signals

Up to 40 analog signals can be selected for recording by the Disturbance recorder and triggering of the Disturbance report function. Out of these 40, 30 are reserved for external analog signals from analog input modules via preprocessing function blocks (SMAI) and summation block (3PHSUM). The last 10 channels may be connected to internally calculated analog signals available as function block output signals (phase differential currents, bias currents and so on).

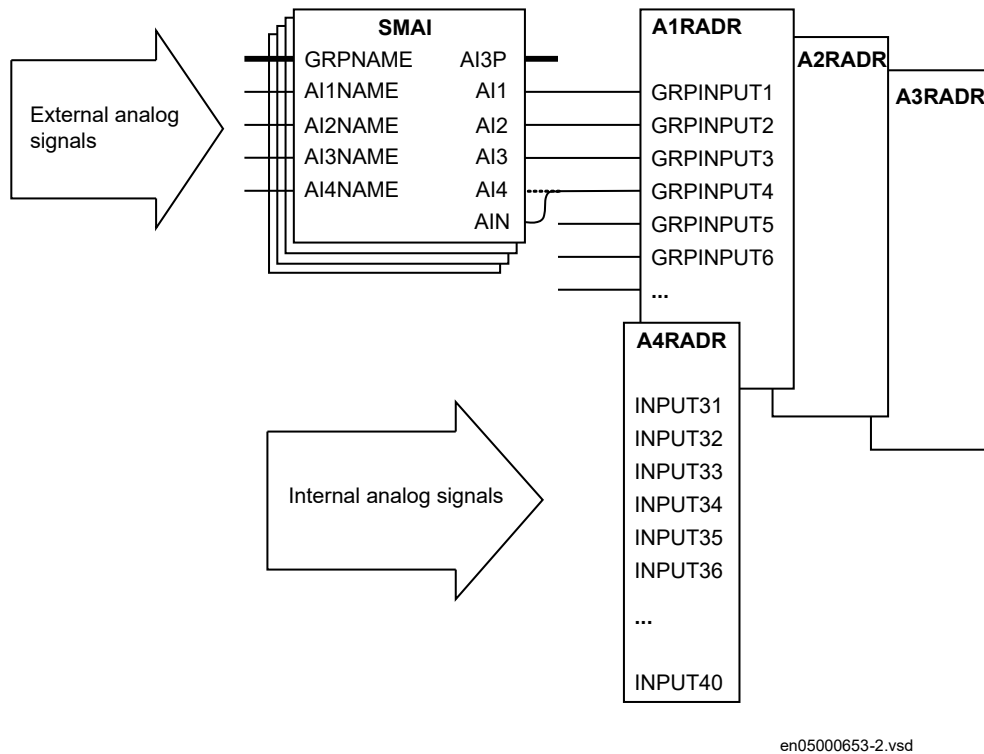

Figure 219: Analog input function blocks

The external input signals will be acquired, filtered and skewed and (after configuration) available as an input signal on the AxRADR function block via the SMAI function block. The information is saved at the Disturbance report base sampling rate (1000 or 1200 Hz). Internally calculated signals are updated according to the cycle time of the specific function. If a function is running at lower speed than the base sampling rate, Disturbance recorder will use the latest updated sample until a new updated sample is available.

Application configuration tool (ACT) is used for analog configuration of the Disturbance report.

The preprocessor function block (SMAI) calculates the residual quantities in cases where only the three phases are connected (AI4-input not used). SMAI makes the information available as a group signal output, phase outputs and calculated residual output (AIN-output). In situations where AI4-input is used as an input signal the corresponding information is available on the non-calculated output (AI4) on the SMAI function block. Connect the signals to the AxRADR accordingly.

For each of the analog signals, *Operation = On* means that it is recorded by the disturbance recorder. The trigger is independent of the setting of *Operation*, and triggers even if operation is set to *Off*. Both undervoltage and overvoltage can be used as trigger conditions. The same applies for the current signals.

If *Operation = Off*, no waveform (samples) will be recorded and reported in graph. However, Trip value, pre-fault and fault value will be recorded and reported. The input channel can still be used to trig the disturbance recorder.

If *Operation = On*, waveform (samples) will also be recorded and reported in graph.

The analog signals are presented only in the disturbance recording, but they affect the entire disturbance report when being used as triggers.

12.4.6.10 Binary signals

Up to 96 binary signals can be selected to be handled by disturbance report. The signals can be selected from internal logical and binary input signals. A binary signal is selected to be recorded when:

- the corresponding function block is included in the configuration
- the signal is connected to the input of the function block

Each of the 96 signals can be selected as a trigger of the disturbance report (*Operation = Off*). A binary signal can be selected to activate the yellow (START) and red (TRIP) LED on the local HMI (*SetLED = Off/Start/Trip/Start and Trip*).

The selected signals are presented in the event recorder, event list and the disturbance recording. But they affect the whole disturbance report when they are used as triggers. The indications are also selected from these 96 signals with local HMI *IndicationMask=Show/Hide*.

12.4.6.11 Trigger signals

The trigger conditions affect the entire disturbance report, except the event list, which runs continuously. As soon as at least one trigger condition is fulfilled, a complete disturbance report is recorded. On the other hand, if no trigger condition is fulfilled, there is no disturbance report, no indications, and so on. This implies the importance of choosing the right signals as trigger conditions.

A trigger can be of type:

- Manual trigger
- Binary-signal trigger
- Analog-signal trigger (over/under function)

Manual trigger

A disturbance report can be manually triggered from the local HMI, PCM600 or via station bus (IEC 61850). When the trigger is activated, the manual trigger signal is generated. This feature is especially useful for testing.

Binary-signal trigger

Any binary signal state (logic one or a logic zero) can be selected to generate a trigger (*Triglevel = Trig on 0/Trig on 1*). When a binary signal is selected to generate a trigger from a logic zero, the selected signal will not be listed in the indications list of the disturbance report.

Analog-signal trigger

All analog signals are available for trigger purposes, no matter if they are recorded in the disturbance recorder or not. The settings are *OverTrigOp*, *UnderTrigOp*, *OverTrigLe* and *UnderTrigLe*.

The check of the trigger condition is based on peak-to-peak values. When this is found, the absolute average value of these two peak values is calculated. If the average value is above the

threshold level for an overvoltage or overcurrent trigger, this trigger is indicated with a greater than (>) sign with the user-defined name.

If the average value is below the set threshold level for an undervoltage or undercurrent trigger, this trigger is indicated with a less than (<) sign with its name. The procedure is separately performed for each channel.

This method of checking the analog start conditions gives a function which is insensitive to DC offset in the signal. The operate time for this start is typically in the range of one cycle, 20 ms for a 50 Hz network.

All under/over trig signal information is available on the local HMI and PCM600.

12.4.6.12 Post Retrigger

Disturbance report function does not automatically respond to any new trig condition during a recording, after all signals set as trigger signals have been reset. However, under certain circumstances the fault condition may reoccur during the post-fault recording, for instance by automatic reclosing to a still faulty power line.

In order to capture the new disturbance it is possible to allow retriggering (*PostRetrig = On*) during the post-fault time. In this case a new, complete recording will start and, during a period, run in parallel with the initial recording.

When the retrig parameter is disabled (*PostRetrig = Off*), a new recording will not start until the post-fault (*PostFaultrecT* or *TimeLimit*) period is terminated. If a new trig occurs during the post-fault period and lasts longer than the proceeding recording a new complete recording will be started.

Disturbance report function can handle maximum 3 simultaneous disturbance recordings.

12.4.7 Technical data

Table 390: DRPRDRE technical data

Function	Range or value	Accuracy
Current recording	-	± 1,0% of I_r at $I \leq I_r$ ± 1,0% of I at $I > I_r$
Voltage recording	-	± 1,0% of U_r at $U \leq U_r$ ± 1,0% of U at $U > U_r$
Pre-fault time	(0.05–3.00) s	-
Post-fault time	(0.1–10.0) s	-
Limit time	(0.5–8.0) s	-
Maximum number of recordings	100, first in - first out	-
Time tagging resolution	1 ms	See time synchronization technical data
Maximum number of analog inputs	30 + 10 (external + internally derived)	-
Maximum number of binary inputs	96	-
Maximum number of phasors in the Trip Value recorder per recording	30	-
Maximum number of indications in a disturbance report	96	-
Table continues on next page		

Function	Range or value	Accuracy
Maximum number of events in the Event recording per recording	150	-
Maximum number of events in the Event list	1000, first in - first out	-
Maximum total recording time (3.4 s recording time and maximum number of channels, typical value)	340 seconds (100 recordings) at 50 Hz, 280 seconds (80 recordings) at 60 Hz	-
Sampling rate	1 kHz at 50 Hz 1.2 kHz at 60 Hz	-
Recording bandwidth	(5-300) Hz	-

12.5 Indications

12.5.1 Functionality

To get fast, condensed and reliable information about disturbances in the primary and/or in the secondary system it is important to know, for example binary signals that have changed status during a disturbance. This information is used in the short perspective to get information via the local HMI in a straightforward way.

There are three LEDs on the local HMI (green, yellow and red), which will display status information about the IED and the Disturbance recorder function (triggered).

The Indication list function shows all selected binary input signals connected to the Disturbance recorder function that have changed status during a disturbance.

12.5.2 Function block

The Indications function has no function block of its own.

12.5.3 Signals

12.5.3.1 Input signals

The Indications function logs the same binary input signals as the Disturbance report function.

12.5.4 Operation principle

The LED indications display this information:

Green LED:

Steady light	In Service
Flashing light	Internal fail
Dark	No power supply

Yellow LED:

Function controlled by *SetLEDn* setting in Disturbance report function.

Red LED:

Function controlled by *SetLEDn* setting in Disturbance report function.

Indication list:

The possible indication signals are the same as the ones chosen for the disturbance report function and disturbance recorder.

The indication function tracks 0 to 1 changes of binary signals during the recording period of the collection window. This means that constant logic zero, constant logic one or state changes from logic one to logic zero will not be visible in the list of indications. Signals are not time tagged. In order to be recorded in the list of indications the:

- the signal must be connected to binary input BxRBDR function block
- the DRPRDRE parameter *Operation* must be set *On*
- the DRPRDRE must be triggered (binary or analog)
- the input signal must change state from logical 0 to 1 during the recording time.

Indications are selected with the indication mask (*IndicationMask*) when setting the binary inputs.

The name of the binary signal that appears in the Indication function is the user-defined name assigned at configuration of the IED. The same name is used in disturbance recorder function, indications and event recorder function.

12.5.5 Technical data

Table 391: DRPRDRE technical data

Function		Value
Buffer capacity	Maximum number of indications presented for single disturbance	96
	Maximum number of recorded disturbances	100

12.6 Event recorder

12.6.1 Functionality

Quick, complete and reliable information about disturbances in the primary and/or in the secondary system is vital, for example, time-tagged events logged during disturbances. This information is used for different purposes in the short term (for example corrective actions) and in the long term (for example functional analysis).

The event recorder logs all selected binary input signals connected to the Disturbance recorder function. Each recording can contain up to 150 time-tagged events.

The event recorder information is available for the disturbances locally in the IED.

The event recording information is an integrated part of the disturbance record (Comtrade file).

12.6.2 Function block

The Event recorder has no function block of it's own.

12.6.3 Signals

12.6.3.1 Input signals

The Event recorder function logs the same binary input signals as the Disturbance report function.

12.6.4 Operation principle

When one of the trig conditions for the disturbance report is activated, the event recorder logs every status change in the 96 selected binary signals. The events can be generated by both internal logical signals and binary input channels. The internal signals are time-tagged in the main processor module, while the binary input channels are time-tagged directly in each I/O module. The events are collected during the total recording time (pre-, post-fault and limit time), and are stored in the disturbance report flash memory at the end of each recording.

In case of overlapping recordings, due to *PostRetrig = On* and a new trig signal appears during post-fault time, events will be saved in both recording files.

The name of the binary input signal that appears in the event recording is the user-defined name assigned when configuring the IED. The same name is used in the disturbance recorder function , indications and event recorder function.

The event record is stored as a part of the disturbance report information and managed via the local HMI or PCM600.



Events can not be read from the IED if more than one user is accessing the IED simultaneously.

12.6.5 Technical data

Table 392: DRPRDRE technical data

Function		Value
Buffer capacity	Maximum number of events in disturbance report	150
	Maximum number of disturbance reports	100
Resolution		1 ms
Accuracy		Depending on time synchronizing

12.7 Event list

12.7.1 Functionality

Continuous event-logging is useful for monitoring the system from an overview perspective and is a complement to specific disturbance recorder functions.

The event list logs all binary input signals connected to the Disturbance recorder function. The list may contain up to 1000 time-tagged events stored in a ring-buffer.

12.7.2 Function block

The Event list has no function block of its own.

12.7.3 Signals

12.7.3.1 Input signals

The Event list logs the same binary input signals as configured for the Disturbance report function.

12.7.4 Operation principle

When a binary signal, connected to the disturbance report function, changes status, the event list function stores input name, status and time in the event list in chronological order. The list can contain up to 1000 events from both internal logic signals and binary input channels. If the list is full, the oldest event is overwritten when a new event arrives.

The list can be configured to show oldest or newest events first with a setting on the local HMI.

The event list function runs continuously, in contrast to the event recorder function, which is only active during a disturbance.

The name of the binary signal that appears in the event recording is the user-defined name assigned when the IED is configured. The same name is used in the disturbance recorder function, indications and the event recorder function.

The event list is stored and managed separate from the disturbance report information.

12.7.5 Technical data

Table 393: DRPRDRE technical data

Function		Value
Buffer capacity	Maximum number of events in the list	1000
Resolution		1 ms
Accuracy		Depending on time synchronizing

12.8 Trip value recorder

12.8.1 Functionality

Information about the pre-fault and fault values for currents and voltages are vital for the disturbance evaluation.

The Trip value recorder calculates the values of all selected analog input signals connected to the Disturbance recorder function. The result is magnitude and phase angle before and during the fault for each analog input signal.

The trip value recorder information is available for the disturbances locally in the IED.

The trip value recorder information is an integrated part of the disturbance record (Comtrade file).

12.8.2 Function block

The Trip value recorder has no function block of its own.

12.8.3 Signals

12.8.3.1 Input signals

The trip value recorder function uses analog input signals connected to A1RADR to A3RADR (not A4RADR).

12.8.4 Operation principle

Trip value recorder calculates and presents both fault and pre-fault amplitudes as well as the phase angles of all the selected analog input signals. The parameter *ZeroAngleRef* points out which input signal is used as the angle reference.

When the disturbance report function is triggered the sample for the fault interception is searched for, by checking the non-periodic changes in the analog input signals. The channel search order is consecutive, starting with the analog input with the lowest number.

When a starting point is found, the Fourier estimation of the pre-fault values of the complex values of the analog signals starts 1.5 cycle before the fault sample. The estimation uses samples during one period. The post-fault values are calculated using the Recursive Least Squares (RLS) method. The calculation starts a few samples after the fault sample and uses samples during $1/2 - 2$ cycles depending on the shape of the signals.

If no starting point is found in the recording, the disturbance report trig sample is used as the start sample for the Fourier estimation. The estimation uses samples during one cycle before the trig sample. In this case the calculated values are used both as pre-fault and fault values.

The name of the analog signal that appears in the Trip value recorder function is the user-defined name assigned when the IED is configured. The same name is used in the Disturbance recorder function .

The trip value record is stored as a part of the disturbance report information (LMBRFLO) and managed in PCM600 or via the local HMI.

12.8.5 Technical data

Table 394: DRPRDRE technical data

Function		Value
Buffer capacity	Maximum number of analog inputs	30
	Maximum number of disturbance reports	100

12.9 Disturbance recorder

12.9.1 Functionality

The Disturbance recorder function supplies fast, complete and reliable information about disturbances in the power system. It facilitates understanding system behavior and related primary and secondary equipment during and after a disturbance. Recorded information is used for different purposes in the short perspective (for example corrective actions) and long perspective (for example functional analysis).

The Disturbance recorder acquires sampled data from selected analog- and binary signals connected to the Disturbance recorder function (maximum 40 analog and 96 binary signals). The binary signals available are the same as for the event recorder function.

The function is characterized by great flexibility and is not dependent on the operation of protection functions. It can record disturbances not detected by protection functions. Up to 9,9 seconds of data before the trigger instant can be saved in the disturbance file.

The disturbance recorder information for up to 100 disturbances are saved in the IED and the local HMI is used to view the list of recordings.

12.9.2 Function block

The Disturbance recorder has no function block of its own.

12.9.3 Signals

See Disturbance report for input and output signals.

12.9.4 Settings

See Disturbance report for settings.

12.9.5 Operation principle

Disturbance recording is based on the acquisition of binary and analog signals. The binary signals can be either true binary input signals or internal logical signals generated by the functions in the IED. The analog signals to be recorded are input channels from the Transformer Input Module (TRM) through the Signal Matrix Analog Input (SMAI) and possible summation (Sum3Ph) function blocks and some internally derived analog signals.

Disturbance recorder collects analog values and binary signals continuously, in a cyclic buffer. The pre-fault buffer operates according to the FIFO principle; old data will continuously be

overwritten as new data arrives when the buffer is full. The size of this buffer is determined by the set pre-fault recording time.

Upon detection of a fault condition (triggering), the disturbance is time tagged and the data storage continues in a post-fault buffer. The storage process continues as long as the fault condition prevails - plus a certain additional time. This is called the post-fault time and it can be set in the disturbance report.

The above mentioned two parts form a disturbance recording. The whole memory, intended for disturbance recordings, acts as a cyclic buffer and when it is full, the oldest recording is overwritten. Up to the last 100 recordings are stored in the IED.

The time tagging refers to the activation of the trigger that starts the disturbance recording. A recording can be triggered by, manual start, binary input and/or from analog inputs (over-/underlevel trig).

A user-defined name for each of the signals can be set. These names are common for all functions within the disturbance report functionality.

12.9.5.1 Memory and storage



The maximum number of recordings depend on each recordings total recording time. Long recording time will reduce the number of recordings to less than 100.



The IED flash disk should NOT be used to store any user files. This might cause disturbance recordings to be deleted due to lack of disk space.

When a recording is completed, a post recording processing occurs.

This post-recording processing comprises:

- Saving the data for analog channels with corresponding data for binary signals
- Add relevant data to be used by the Disturbance handling tool (part of PCM 600)
- Compression of the data, which is performed without losing any data accuracy
- Storing the compressed data in a non-volatile memory (flash memory)

The recorded disturbance is now ready for retrieval and evaluation.

The recording files comply with the Comtrade standard IEC 60255-24 and are divided into three files; a header file (HDR), a configuration file (CFG) and a data file (DAT).

The header file (optional in the standard) contains basic information about the disturbance, that is, information from the Disturbance report sub-functions. The Disturbance handling tool use this information and present the recording in a user-friendly way.

General:

- Station name, object name and unit name
- Date and time for the trig of the disturbance
- Record number
- Sampling rate
- Time synchronization source
- Recording times
- Activated trig signal
- Active setting group

Analog:

- Signal names for selected analog channels
- Information e.g. trig on analog inputs
- Primary and secondary instrument transformer rating
- Over- or Undertrig: level and operation
- Over- or Undertrig status at time of trig
- CT direction

Binary:

- Signal names
- Status of binary input signals

The configuration file is a mandatory file containing information needed to interpret the data file. For example sampling rate, number of channels, system frequency, channel info etc.

The data file, which also is mandatory, containing values for each input channel for each sample in the record (scaled value). The data file also contains a sequence number and time stamp for each set of samples.

12.9.6 Technical data

Table 395: DRPRDRE technical data

Function		Value
Buffer capacity	Maximum number of analog inputs	40
	Maximum number of binary inputs	96
	Maximum number of disturbance reports	100
Maximum total recording time (3.4 s recording time and maximum number of channels, typical value)		340 seconds (100 recordings) at 50 Hz 280 seconds (80 recordings) at 60 Hz

12.10 IEC 61850 generic communication I/O functions SPGGIO

12.10.1 Identification

Function description	IEC 61850 identification	IEC 60617 identification	ANSI/IEEE C37.2 device number
IEC 61850 generic communication I/O functions	SPGGIO	-	-

12.10.2 Functionality

IEC61850 generic communication I/O functions SPGGIO is used to send one single logical signal to other systems or equipment in the substation.

12.10.3 Function block

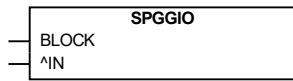

IEC09000237_en_1.vsd

Figure 220: SPGGIO function block

12.10.4 Signals

Table 396: SPGGIO Input signals

Name	Type	Default	Description
BLOCK	BOOLEAN	0	Block of function
IN	BOOLEAN	0	Input status

12.10.5 Settings

The function does not have any parameters available in Local HMI or Protection and Control IED Manager (PCM600).

12.10.6 Operation principle

Upon receiving a signal at its input, IEC61850 generic communication I/O functions (SPGGIO) function sends the signal over IEC 61850-8-1 to the equipment or system that requests this signal. To get the signal, PCM600 must be used to define which function block in which equipment or system should receive this information.

12.11 IEC 61850 generic communication I/O functions 16 inputs SP16GGIO

12.11.1 Identification

Function description	IEC 61850 identification	IEC 60617 identification	ANSI/IEEE C37.2 device number
IEC 61850 generic communication I/O functions 16 inputs	SP16GGIO	-	-

12.11.2 Functionality

IEC 61850 generic communication I/O functions 16 inputs SP16GGIO function is used to send up to 16 logical signals to other systems or equipment in the substation.

12.11.3 Function block

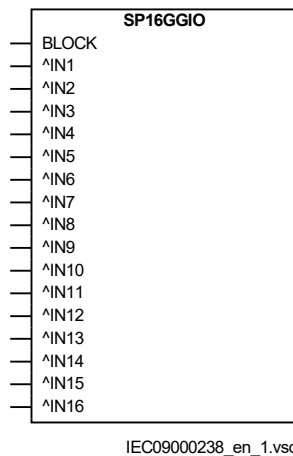

Figure 221: SP16GGIO function block

12.11.4 Signals

Table 397: SP16GGIO Input signals

Name	Type	Default	Description
BLOCK	BOOLEAN	0	Block of function
IN1	BOOLEAN	0	Input 1 status
IN2	BOOLEAN	0	Input 2 status
IN3	BOOLEAN	0	Input 3 status
IN4	BOOLEAN	0	Input 4 status
IN5	BOOLEAN	0	Input 5 status
IN6	BOOLEAN	0	Input 6 status
IN7	BOOLEAN	0	Input 7 status
IN8	BOOLEAN	0	Input 8 status
IN9	BOOLEAN	0	Input 9 status
IN10	BOOLEAN	0	Input 10 status
IN11	BOOLEAN	0	Input 11 status
IN12	BOOLEAN	0	Input 12 status
IN13	BOOLEAN	0	Input 13 status
IN14	BOOLEAN	0	Input 14 status
IN15	BOOLEAN	0	Input 15 status
IN16	BOOLEAN	0	Input 16 status

12.11.5 Settings

The function does not have any parameters available in Local HMI or Protection and Control IED Manager (PCM600).

12.11.6 MonitoredData

Table 398: SP16GGIO Monitored data

Name	Type	Values (Range)	Unit	Description
OUT1	GROUP SIGNAL	-	-	Output 1 status
OUT2	GROUP SIGNAL	-	-	Output 2 status
OUT3	GROUP SIGNAL	-	-	Output 3 status
OUT4	GROUP SIGNAL	-	-	Output 4 status
OUT5	GROUP SIGNAL	-	-	Output 5 status
OUT6	GROUP SIGNAL	-	-	Output 6 status
OUT7	GROUP SIGNAL	-	-	Output 7 status
OUT8	GROUP SIGNAL	-	-	Output 8 status
OUT9	GROUP SIGNAL	-	-	Output 9 status
OUT10	GROUP SIGNAL	-	-	Output 10 status
OUT11	GROUP SIGNAL	-	-	Output 11 status
OUT12	GROUP SIGNAL	-	-	Output 12 status
OUT13	GROUP SIGNAL	-	-	Output 13 status
OUT14	GROUP SIGNAL	-	-	Output 14 status
OUT15	GROUP SIGNAL	-	-	Output 15 status
OUT16	GROUP SIGNAL	-	-	Output 16 status
OUTOR	GROUP SIGNAL	-	-	Output status logic OR gate for input 1 to 16

12.11.7 Operation principle

Upon receiving signals at its inputs, IEC 61850 generic communication I/O functions 16 inputs (SP16GGIO) function will send the signals over IEC 61850-8-1 to the equipment or system that requests this signals. To be able to get the signal, one must use other tools, described in the Engineering manual and define which function block in which equipment or system should receive this information.

There are also 16 output signals that show the input status for each input as well as an OR type output combined for all 16 input signals. These output signals are handled in PST.

12.12 IEC 61850 generic communication I/O functions MVGGIO

12.12.1 Identification

Function description	IEC 61850 identification	IEC 60617 identification	ANSI/IEEE C37.2 device number
IEC61850 generic communication I/O functions	MVGGIO	-	-

12.12.2 Functionality

IEC61850 generic communication I/O functions (MVGGIO) function is used to send the instantaneous value of an analog signal to other systems or equipment in the substation. It can also be used inside the same IED, to attach a RANGE aspect to an analog value and to permit measurement supervision on that value.

12.12.3 Function block

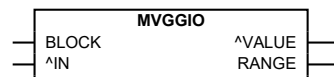

IEC09000239-2-en.vsd

12.12.4 Signals

Table 399: MVGGIO Input signals

Name	Type	Default	Description
BLOCK	BOOLEAN	0	Block of function
IN	REAL	0	Analog input value

Table 400: MVGGIO Output signals

Name	Type	Description
VALUE	REAL	Magnitude of deadband value
RANGE	INTEGER	Range

12.12.5 Settings

Table 401: MVGGIO Non group settings (basic)

Name	Values (Range)	Unit	Step	Default	Description
BasePrefix	micro milli unit kilo Mega Giga Tera	-	-	unit	Base prefix (multiplication factor)
MV db	1 - 300	Type	1	10	Cycl: Report interval (s), Db: In % of range, Int Db: In %s
MV zeroDb	0 - 100000	m%	1	500	Zero point clamping in 0,001% of range
MV hhLim	-5000.00 - 5000.00	xBase	0.01	900.00	High High limit multiplied with the base prefix (multiplication factor)
MV hLim	-5000.00 - 5000.00	xBase	0.01	800.00	High limit multiplied with the base prefix (multiplication factor)
MV lLim	-5000.00 - 5000.00	xBase	0.01	-800.00	Low limit multiplied with the base prefix (multiplication factor)
MV llLim	-5000.00 - 5000.00	xBase	0.01	-900.00	Low Low limit multiplied with the base prefix (multiplication factor)
MV min	-5000.00 - 5000.00	xBase	0.01	-1000.00	Minimum value multiplied with the base prefix (multiplication factor)
MV max	-5000.00 - 5000.00	xBase	0.01	1000.00	Maximum value multiplied with the base prefix (multiplication factor)
MV dbType	Cyclic Dead band Int deadband	-	-	Dead band	Reporting type
MV limHys	0.000 - 100.000	%	0.001	5.000	Hysteresis value in % of range (common for all limits)

12.12.6 Monitored data

Table 402: MVGGIO Monitored data

Name	Type	Values (Range)	Unit	Description
VALUE	REAL	-	-	Magnitude of deadband value
RANGE	INTEGER	0=Normal 1=High 2=Low 3=High-High 4=Low-Low	-	Range

12.12.7 Operation principle

Upon receiving an analog signal at its input, IEC61850 generic communication I/O functions (MVGGIO) will give the instantaneous value of the signal and the range, as output values. In the same time, it will send over IEC 61850-8-1 the value, to other IEC 61850 clients in the substation.

12.13 Measured value expander block MVEXP

12.13.1 Identification

Function description	IEC 61850 identification	IEC 60617 identification	ANSI/IEEE C37.2 device number
Measured value expander block	MVEXP	-	-

12.13.2 Functionality

The current and voltage measurements functions (CVMMXN, CMMXU, VMMXU and VNMMXU), current and voltage sequence measurement functions (CMSQI and VMSQI) and IEC 61850 generic communication I/O functions (MVGGIO) are provided with measurement supervision functionality. All measured values can be supervised with four settable limits: low-low limit, low limit, high limit and high-high limit. The measure value expander block MVEXP has been introduced to enable translating the integer output signal from the measuring functions to 5 binary signals: below low-low limit, below low limit, normal, above high limit or above high-high limit. The output signals can be used as conditions in the configurable logic or for alarming purpose.

12.13.3 Function block

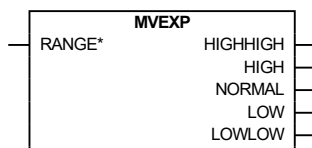

IEC09000215-1-en.vsd

Figure 222: MVEXP function block

12.13.4 Signals

Table 403: MVEXP Input signals

Name	Type	Default	Description
RANGE	INTEGER	0	Measured value range

Table 404: MVEXP Output signals

Name	Type	Description
HIGHHIGH	BOOLEAN	Measured value is above high-high limit
HIGH	BOOLEAN	Measured value is between high and high-high limit
NORMAL	BOOLEAN	Measured value is between high and low limit
LOW	BOOLEAN	Measured value is between low and low-low limit
LOWLOW	BOOLEAN	Measured value is below low-low limit

12.13.5 Settings

The function does not have any parameters available in Local HMI or Protection and Control IED Manager (PCM600).

GlobalBaseSel: Selects the global base value group used by the function to define (*IBase*), (*UBase*) and (*SBase*).

12.13.6 Operation principle

The input signal must be connected to a range output of a measuring function block (CVMMXN, CMMXU, VMMXU, VNMMXU, CMSQI, VMSQ or MVGGIO). The function block converts the input integer value to five binary output signals according to [table 405](#).

Table 405: Input integer value converted to binary output signals

Measured supervised value is: Output:	below low-low limit	between low-low and low limit	between low and high limit	between high-high and high limit	above high-high limit
LOWLOW	High				
LOW		High			
NORMAL			High		
HIGH				High	
HIGHHIGH					High

12.14 Fault locator LMBRFLO

12.14.1 Identification

Function description	IEC 61850 identification	IEC 60617 identification	ANSI/IEEE C37.2 device number
Fault locator	LMBRFLO	-	-

12.14.2 Functionality

The Fault locator LMBRFLO in the IED is an essential complement to other monitoring functions, since it measures and indicates the distance to the fault with great accuracy. It indicates the distance to fault in kilometers or miles as selected by parameter setting.



The fault locator LMBRFLO function, supports kilometer and mile for the line length unit. The fault distance will be presented with the same unit as the line length and is mapped to IEC61850 -8-1 communication protocol, where the fault distance is supposed to be in kilometer (km). Select the line length unit to kilometer for compliance with IEC61850.

The accurate fault locator is an essential component to minimize the outages after a persistent fault and/or to pin-point a weak spot on the line.

The fault locator is an impedance measuring function giving the distance to the fault km or miles. The main advantage is the high accuracy achieved by compensating for load current and for the mutual zero-sequence effect on double circuit lines.

The compensation includes setting of the remote and local sources and calculation of the distribution of fault currents from each side. This distribution of fault current, together with recorded load (pre-fault) currents, is used to exactly calculate the fault position. The fault can be recalculated with new source data at the actual fault to further increase the accuracy.

Especially on heavily loaded long lines, where the source voltage angles can be up to 35-40 degrees apart, the accuracy can be still maintained with the advanced compensation included in fault locator.

12.14.3 Function block

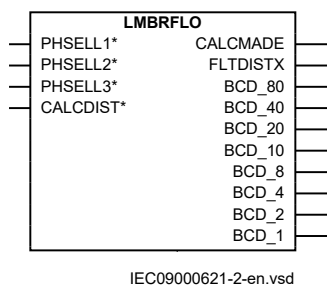

Figure 223: LMBRFLO function block

12.14.4 Signals

Table 406: LMBRFLO Input signals

Name	Type	Default	Description
PHSELL1	BOOLEAN	0	Phase selecton L1
PHSELL2	BOOLEAN	0	Phase selecton L2
PHSELL3	BOOLEAN	0	Phase selecton L3
CALCDIST	BOOLEAN	0	Do calculate fault distance (release)

Table 407: LMBRFLO Output signals

Name	Type	Description
CALCMADE	BOOLEAN	Fault calculation made
FLT_X	REAL	Reactive distance to fault
BCD_80	BOOLEAN	Distance in binary coded data, bit represents 80%
BCD_40	BOOLEAN	Distance in binary coded data, bit represents 40%
BCD_20	BOOLEAN	Distance in binary coded data, bit represents 20%
BCD_10	BOOLEAN	Distance in binary coded data, bit represents 10%
BCD_8	BOOLEAN	Distance in binary coded data, bit represents 8%

Table continues on next page

Name	Type	Description
BCD_4	BOOLEAN	Distance in binary coded data, bit represents 4%
BCD_2	BOOLEAN	Distance in binary coded data, bit represents 2%
BCD_1	BOOLEAN	Distance in binary coded data, bit represents 1%

12.14.5 Settings

Table 408: LMBRFLO Group settings (basic)

Name	Values (Range)	Unit	Step	Default	Description
R1A	0.001 - 1500.000	ohm/p	0.001	2.000	Source resistance A (near end)
X1A	0.001 - 1500.000	ohm/p	0.001	12.000	Source reactance A (near end)
R1B	0.001 - 1500.000	ohm/p	0.001	2.000	Source resistance B (far end)
X1B	0.001 - 1500.000	ohm/p	0.001	12.000	Source reactance B (far end)
R1L	0.001 - 1500.000	ohm/p	0.001	2.000	Positive sequence line resistance
X1L	0.001 - 1500.000	ohm/p	0.001	12.500	Positive sequence line reactance
R0L	0.001 - 1500.000	ohm/p	0.001	8.750	Zero sequence line resistance
X0L	0.001 - 1500.000	ohm/p	0.001	50.000	Zero sequence line reactance
R0M	0.000 - 1500.000	ohm/p	0.001	0.000	Zero sequence mutual resistance
X0M	0.000 - 1500.000	ohm/p	0.001	0.000	Zero sequence mutual reactance
LineLengthUnit	kilometer miles	-	-	kilometer	Line length unit
LineLength	0.0 - 10000.0	-	0.1	40.0	Length of line

Table 409: LMBRFLO Non group settings (basic)

Name	Values (Range)	Unit	Step	Default	Description
DrepChNoIL1	1 - 30	Ch	1	1	Recorder input number recording phase current, IL1
DrepChNoIL2	1 - 30	Ch	1	2	Recorder input number recording phase current, IL2
DrepChNoIL3	1 - 30	Ch	1	3	Recorder input number recording phase current, IL3
DrepChNoIN	0 - 30	Ch	1	4	Recorder input number recording residual current, IN
DrepChNoIP	0 - 30	Ch	1	0	Recorder input number recording 3I0 on parallel line
DrepChNoUL1	1 - 30	Ch	1	5	Recorder input number recording phase voltage, UL1
DrepChNoUL2	1 - 30	Ch	1	6	Recorder input number recording phase voltage, UL2
DrepChNoUL3	1 - 30	Ch	1	7	Recorder input number recording phase voltage, UL3

12.14.6 Monitored data

Table 410: LMBRFLO Monitored data

Name	Type	Values (Range)	Unit	Description
FLT_REL	REAL	-	-	Distance to fault, relative
FLT_DIST	REAL	-	-	Distance to fault in line length unit
FLT_X	REAL	-	Ohm	Reactive distance to fault
FLT_R	REAL	-	Ohm	Resistive distance to fault
FLT_LOOP	INTEGER	0=--- 1=L1-N 2=L2-N 3=L3-N 4=L1-L2 5=L2-L3 6=L3-L1 7=L1-L2-L3	-	Fault loop

12.14.7 Operation principle

The Fault locator (LMBRFLO) in the IED is an essential complement to other monitoring functions, since it measures and indicates the distance to the fault with high accuracy.

When calculating distance to fault, pre-fault and fault phasors of currents and voltages are selected from the Trip value recorder data, thus the analog signals used by the fault locator must be among those connected to the disturbance report function. The analog configuration (channel selection) is performed using the parameter setting tool within PCM600.

The calculation algorithm considers the effect of load currents, double-end infeed and additional fault resistance.

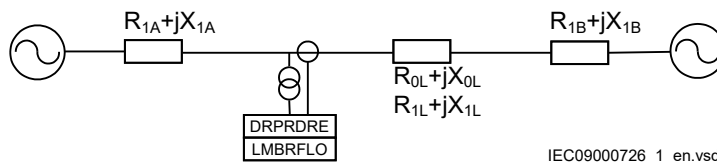

Figure 224: Simplified network configuration with network data, required for settings of the fault location-measuring function

If source impedance in the near and far end of the protected line have changed in a significant manner relative to the set values at fault location calculation time (due to exceptional switching state in the immediate network, power generation out of order, and so on), new values can be entered via the local HMI and a recalculation of the distance to the fault can be ordered using the algorithm described below. It's also possible to change fault loop. In this way, a more accurate location of the fault can be achieved.

The function indicates the distance to the fault as a percentage of the line length, in kilometers or miles as selected on the local HMI. *LineLengthUnit* setting is used to select the unit of length either, in *kilometer* or *miles* for the distance to fault. Line length unit can also be configured using PCM600. The fault location is stored as a part of the disturbance report information and managed via the LHMI or PCM600.

12.14.7.1 Measuring Principle

For transmission lines with voltage sources at both line ends, the effect of double-end infeed and additional fault resistance must be considered when calculating the distance to the fault from the currents and voltages at one line end. If this is not done, the accuracy of the calculated figure will vary with the load flow and the amount of additional fault resistance.

The calculation algorithm used in the fault locator in compensates for the effect of double-end infeed, additional fault resistance and load current.

12.14.7.2 Accurate algorithm for measurement of distance to fault

Figure 225 shows a single-line diagram of a single transmission line, that is fed from both ends with source impedances Z_A and Z_B . Assume that the fault occurs at a distance F from IED A on a line with the length L and impedance Z_L . The fault resistance is defined as R_F . A single-line model is used for better clarification of the algorithm.

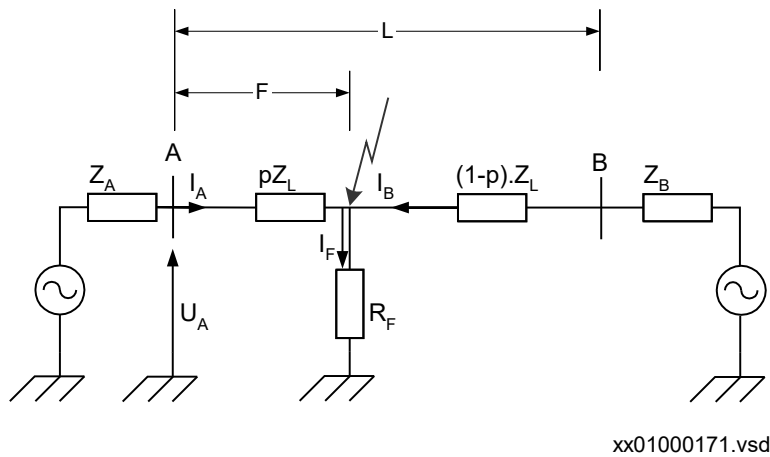

Figure 225: Fault on transmission line fed from both ends

From figure 225 it is evident that:

$$U_A = I_A \cdot p \cdot Z_L + I_F \cdot R_F$$

(Equation 61)

Where:

I_A is the line current after the fault, that is, pre-fault current plus current change due to the fault,

I_F is the fault current and

p is a relative distance to the fault

The fault current is expressed in measurable quantities by:

$$I_F = \frac{I_{FA}}{D_A}$$

(Equation 62)

Where:

I_{FA} is the change in current at the point of measurement, IED A and

D_A is a fault current-distribution factor, that is, the ratio between the fault current at line end A and the total fault current.

For a single line, the value is equal to:

$$D_A = \frac{(1-p) \cdot Z_L + Z_B}{Z_A + Z_L + Z_B}$$

(Equation 63)

Thus, the general fault location equation for a single line is:

$$U_A = I_A \cdot p \cdot Z_L + \frac{I_{FA}}{D_A} \cdot R_F$$

(Equation 64)

Table 411: Expressions for U_A , I_A and I_{FA} for different types of faults

Fault type:	U_A	I_A	I_{FA}
L1-N	U_{L1A}	$I_{L1A} + K_N \times I_{NA}$	$\frac{3}{2} \times \Delta(I_{L1A} - I_{0A})$
L2-N	U_{L2A}	$I_{L2A} + K_N \times I_{NA}$	$\frac{3}{2} \times \Delta(I_{L2A} - I_{0A})$
L3-N	U_{L3A}	$I_{L3A} + K_N \times I_{NA}$	$\frac{3}{2} \times \Delta(I_{L3A} - I_{0A})$
L1-L2-L3, L1-L2, L1-L2-N	$U_{L1A} - U_{L2A}$	$I_{L1A} - I_{L2A}$	ΔI_{L1L2A}
L2-L3, L2-L3-N	$U_{L2A} - U_{L3A}$	$I_{L2A} - I_{L3A}$	ΔI_{L2L3A}
L3-L1, L3-L1-N	$U_{L3A} - U_{L1A}$	$I_{L3A} - I_{L1A}$	ΔI_{L3L1A}

The K_N complex quantity for zero-sequence compensation for the single line is equal to:

$$K_N = \frac{Z_{0L} - Z_{1L}}{3 \cdot Z_{1L}}$$

(Equation 65)

ΔI is the change in current, that is the current after the fault minus the current before the fault.

In the following, the positive sequence impedance for Z_A , Z_B and Z_L is inserted into the equations, because this is the value used in the algorithm.

For double lines, the fault equation is:

$$U_A = I_A \cdot p \cdot Z_{1L} + \frac{I_{FA}}{D_A} \cdot R_F + I_{0P} \cdot Z_{0M}$$

(Equation 66)

Where:

I_{0P} is a zero sequence current of the parallel line,

Z_{0M} is a mutual zero sequence impedance and

D_A is the distribution factor of the parallel line, which is:

$$D_A = \frac{(1-p) \cdot (Z_A + Z_{AL} + Z_B) + Z_B}{2 \cdot Z_A + Z_L + 2 \cdot Z_B}$$

The K_N compensation factor for the double line becomes:

$$K_N = \frac{Z_{0L} - Z_{1L}}{3 \cdot Z_{1L}} + \frac{Z_{0M}}{3 \cdot Z_{1L}} \cdot \frac{I_{0P}}{I_{0A}}$$

(Equation 67)

From these equations it can be seen, that, if $Z_{0m} = 0$, then the general fault location equation for a single line is obtained. Only the distribution factor differs in these two cases.

Because the D_A distribution factor according to equation 64 or 66 is a function of p , the general equation 66 can be written in the form:

$$p^2 - p \cdot K_1 + K_2 - K_3 \cdot R_F = 0$$

(Equation 68)

Where:

$$K_1 = \frac{U_A}{I_A \cdot Z_L} + \frac{Z_B}{Z_L + Z_{ADD}} + 1$$

(Equation 69)

$$K_2 = \frac{U_A}{I_A \cdot Z_L} \cdot \left(\frac{Z_B}{Z_L + Z_{ADD}} + 1 \right)$$

(Equation 70)

$$K_3 = \frac{I_{FA}}{I_A \cdot Z_L} \cdot \left(\frac{Z_A + Z_B}{Z_1 + Z_{ADD}} + 1 \right)$$

(Equation 71)

and:

- $Z_{ADD} = Z_A + Z_B$ for parallel lines.
- I_A , I_{FA} and U_A are given in the above table.
- K_N is calculated automatically according to equation 67.
- Z_A , Z_B , Z_L , Z_{OL} and Z_{OM} are setting parameters.

For a single line, $Z_{OM} = 0$ and $Z_{ADD} = 0$. Thus, equation 68 applies to both single and parallel lines.

Equation 68 can be divided into real and imaginary parts:

$$p^2 - p \cdot \operatorname{Re}(K_1) + \operatorname{Re}(K_2) - R_F \cdot \operatorname{Re}(K_3) = 0$$

(Equation 72)

$$-p \cdot \operatorname{Im}(K_1) + \operatorname{Im}(K_2) - R_F \cdot \operatorname{Im}(K_3) = 0$$

(Equation 73)

If the imaginary part of K_3 is not zero, R_F can be solved according to equation 73, and then inserted to equation 72. According to equation 72, the relative distance to the fault is solved as the root of a quadratic equation.

Equation 72 gives two different values for the relative distance to the fault as a solution. A simplified load compensated algorithm, which gives an unequivocal figure for the relative distance to the fault, is used to establish the value that should be selected.

If the load compensated algorithms according to the above do not give a reliable solution, a less accurate, non-compensated impedance model is used to calculate the relative distance to the fault.

12.14.7.3 The non-compensated impedance model

In the non-compensated impedance model, I_A line current is used instead of I_{FA} fault current:

$$U_A = p \cdot Z_{1L} \cdot I_A + R_F \cdot I_A$$

(Equation 74)

Where:

I_A is according to table 411.

The accuracy of the distance-to-fault calculation, using the non-compensated impedance model, is influenced by the pre-fault load current. So, this method is only used if the load compensated models do not function.

12.14.8 Technical data

Table 412: LMBRFLO technical data

Function	Value or range	Accuracy
Reactive and resistive reach	(0.001-1500.000) Ω/phase	± 2.0% static accuracy ± 2.0% degrees static angular accuracy Conditions: Voltage range: (0.1-1.1) x U _r Current range: (0.5-30) x I _r
Phase selection	According to input signals	-
Maximum number of fault locations	100	-

12.15 Station battery supervision SPVNZBAT

12.15.1 Identification

Function description	IEC 61850 identification	IEC 60617 identification	ANSI/IEEE C37.2 device number
Station battery supervision function	SPVNZBAT	U<>	-

12.15.2 Function block

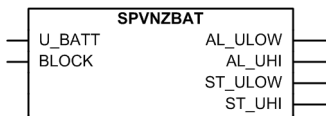

Figure 226: Function block

12.15.3 Functionality

The station battery supervision function SPVNZBAT is used for monitoring battery terminal voltage.

SPVNZBAT activates the start and alarm outputs when the battery terminal voltage exceeds the set upper limit or drops below the set lower limit. A time delay for the overvoltage and undervoltage alarms can be set according to definite time characteristics.

SPVNZBAT operates after a settable operate time and resets when the battery undervoltage or overvoltage condition disappears after settable reset time.

12.15.4 Signals

Table 413: SPVNZBAT Input signals

Name	Type	Default	Description
U_BATT	REAL	0.00	Battery terminal voltage that has to be supervised
BLOCK	BOOLEAN	0	Blocks all the output signals of the function

Table 414: SPVNZBAT Output signals

Name	Type	Description
AL_ULOW	BOOLEAN	Alarm when voltage has been below low limit for a set time
AL_UHI	BOOLEAN	Alarm when voltage has exceeded high limit for a set time
ST_ULOW	BOOLEAN	Start signal when battery voltage drops below lower limit
ST_UHI	BOOLEAN	Start signal when battery voltage exceeds upper limit

12.15.5 Settings

Table 415: SPVNZBAT Non group settings (basic)

Name	Values (Range)	Unit	Step	Default	Description
Operation	Off On	-	-	On	Operation mode Off / On
RtdBattVolt	20.00 - 250.00	V	1.00	110.00	Battery rated voltage
BattVoltLowLim	60 - 140	%Ubat	1	70	Lower limit for the battery terminal voltage
BattVoltHiLim	60 - 140	%Ubat	1	120	Upper limit for the battery terminal voltage
tDelay	0.000 - 60.000	s	0.001	0.200	Delay time for alarm
tReset	0.000 - 60.000	s	0.001	0.000	Time delay for reset of alarm

12.15.6 Measured values

Table 416: SPVNZBAT Measured values

Name	Type	Default	Description
U_BATT	REAL	0.00	Battery terminal voltage that has to be supervised
BLOCK	BOOLEAN	0	Blocks all the output signals of the function

12.15.7 Monitored Data

Table 417: SPVNZBAT Monitored data

Name	Type	Values (Range)	Unit	Description
BATTVOLT	REAL	-	kV	Service value of the battery terminal voltage

12.15.8 Operation principle

The function can be enabled and disabled with the *Operation* setting. The corresponding parameter values are "On" and "Off".



The function execution requires that at least one of the function outputs is connected in configuration.

The operation of the station battery supervision function can be described by using a module diagram. All the modules in the diagram are explained in the next sections.

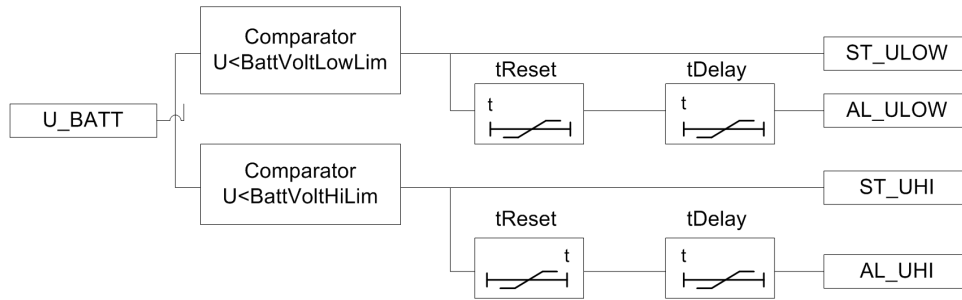

Figure 227: Functional module diagram

The battery rated voltage is set with the *RtdBattVolt* setting. The value of the *BattVoltLowLim* and *BattVoltHiLim* settings are given in relative per unit to the *RtdBattVolt* setting.

It is possible to block the function outputs by the `BLOCK` input.

Low level detector

The level detector compares the battery voltage `U_BATT` with the set value of the *BattVoltLowLim* setting. If the value of the `U_BATT` input drops below the set value of the *BattVoltLowLim* setting, the start signal `ST_ULOW` is activated.

The measured voltage between the battery terminals `U_BATT` is available through the Monitored data view.

High level detector

The level detector compares the battery voltage `U_BATT` with the set value of the *BattVoltHiLim* setting. If the value of the `U_BATT` input exceeds the set value of the *BattVoltHiLim* setting, the start signal `ST_UHI` is activated.

Time delay

When the operate timer has reached the value set by the *tDelay* setting, the `AL_ULOW` and `AL_UHI` outputs are activated. If the voltage returns to the normal value before the module operates, the reset timer is activated. If the reset timer reaches the value set by *tReset*, the operate timer resets and the `ST_ULOW` and `ST_UHI` outputs are deactivated.

12.15.9 Technical data

Table 418: SPVNZBAT Technical data

Function	Range or value	Accuracy
Lower limit for the battery terminal voltage	(60-140) % of Ubat	± 1.0% of set battery voltage
Reset ratio, lower limit	<105 %	-
Upper limit for the battery terminal voltage	(60-140) % of Ubat	± 1.0% of set battery voltage
Reset ratio, upper limit	>95 %	-
Timers	(0.000-60.000) s	± 0.5% ± 110 ms
Battery rated voltage	20-250V	-

12.16 Insulation gas monitoring function SSIMG

12.16.1 Identification

Function description	IEC 61850 identification	IEC 60617 identification	ANSI/IEEE C37.2 device number
Insulation gas monitoring function	SSIMG	-	63

12.16.2 Functionality

Insulation gas monitoring function SSIMG is used for monitoring the circuit breaker condition. Binary information based on the gas pressure in the circuit breaker is used as input signals to the function. In addition, the function generates alarms based on received information.

12.16.3 Function block

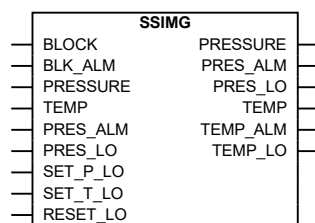

IEC09000129-1-en.vsd

Figure 228: SSIMG function block

12.16.4 Signals



Inputs PRESSURE and TEMP together with settings *PressAlmLimit*, *PressLOLimit*, *TempAlarmLimit* and *TempLOLimit* are not supported in this release of 650 series.

Table 419: SSIMG Input signals

Name	Type	Default	Description
BLOCK	BOOLEAN	0	Block of function
BLK_ALM	BOOLEAN	0	Block all the alarms
PRESSURE	REAL	0.0	Pressure input from CB
TEMP	REAL	0.0	Temperature of the insulation medium from CB
PRES_ALM	BOOLEAN	0	Pressure alarm signal
PRES_LO	BOOLEAN	0	Pressure lockout signal
SET_P_LO	BOOLEAN	0	Set pressure lockout
SET_T_LO	BOOLEAN	0	Set temperature lockout
RESET_LO	BOOLEAN	0	Reset pressure and temperature lockout

Table 420: SSIMG Output signals

Name	Type	Description
PRESSURE	REAL	Pressure service value
PRES_ALM	BOOLEAN	Pressure below alarm level
PRES_LO	BOOLEAN	Pressure below lockout level
TEMP	REAL	Temperature of the insulation medium
TEMP_ALM	BOOLEAN	Temperature above alarm level
TEMP_LO	BOOLEAN	Temperature above lockout level

12.16.5 Settings

Table 421: SSIMG Group settings (basic)

Name	Values (Range)	Unit	Step	Default	Description
Operation	Off On	-	-	Off	Operation Off / On
PressAlmLimit	0.00 - 25.00	-	0.01	5.00	Alarm setting for pressure
PressLOLimit	0.00 - 25.00	-	0.01	3.00	Pressure lockout setting
TempAlarmLimit	-40.00 - 200.00	-	0.01	30.00	Temperature alarm level setting of the medium
TempLOLimit	-40.00 - 200.00	-	0.01	30.00	Temperature lockout level of the medium
tPressureAlarm	0.000 - 60.000	s	0.001	0.000	Time delay for pressure alarm

Table continues on next page

Name	Values (Range)	Unit	Step	Default	Description
tPressureLO	0.000 - 60.000	s	0.001	0.000	Time delay for pressure lockout indication
tTempAlarm	0.000 - 60.000	s	0.001	0.000	Time delay for temperature alarm
tTempLockOut	0.000 - 60.000	s	0.001	0.000	Time delay for temperature lockout
tResetPressAlm	0.000 - 60.000	s	0.001	0.000	Reset time delay for pressure alarm
tResetPressLO	0.000 - 60.000	s	0.001	0.000	Reset time delay for pressure lockout
tResetTempLO	0.000 - 60.000	s	0.001	0.000	Reset time delay for temperature lockout
tResetTempAlm	0.000 - 60.000	s	0.001	0.000	Reset time delay for temperature alarm

12.16.6 Operation principle

Insulation gas monitoring function SSIMG is used to monitor gas pressure in the circuit breaker. Two binary output signals are used from the circuit breaker to initiate alarm signals, pressure below alarm level and pressure below lockout level. If the input signal PRES_ALM is high, which indicate that the gas pressure in the circuit breaker is below alarm level, the function initiates output signal PRES_ALM, pressure below alarm level, after a set time delay and indicate that maintenance of the circuit breaker is required. Similarly, if the input signal PRES_LO is high, which indicate gas pressure in the circuit breaker is below lockout level, the function initiates output signal PRES_LO, after a time delay. The two time delay settings, *tPressureAlarm* and *tPressureLO*, are included in order not to initiate any alarm for short sudden changes in the gas pressure. If the gas pressure in the circuit breaker goes below the levels for more than the set time delays the corresponding signals, PRES_ALM, pressure below alarm level and PRES_LO, pressure below lockout level alarm will be obtained.

The input signal BLK_ALM is used to block the two alarms levels. The input signal BLOCK is used to block both the alarms and the function.

12.16.7 Technical data

Table 422: SSIMG Technical data

Function	Range or value	Accuracy
Timers	(0.000-60.000) s	± 0.5% ± 110 ms

12.17 Insulation liquid monitoring function SSIML

12.17.1 Identification

Function description	IEC 61850 identification	IEC 60617 identification	ANSI/IEEE C37.2 device number
Insulation liquid monitoring function	SSIML	-	71

12.17.2 Functionality

Insulation liquid monitoring function SSIML is used for monitoring the circuit breaker condition. Binary information based on the oil level in the circuit breaker is used as input

signals to the function. In addition, the function generates alarms based on received information.

12.17.3 Function block

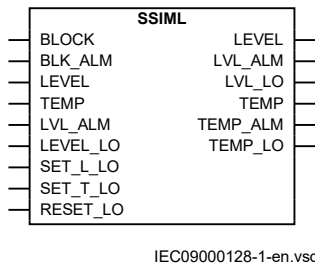

Figure 229: SSIML function block

12.17.4 Signals



Inputs LEVEL and TEMP together with settings *LevelAlmLimit*, *LevelLOLimit*, *TempAlarmLimit* and *TempLOLimit* are not supported in this release of 650 series.

Table 423: SSIML Input signals

Name	Type	Default	Description
BLOCK	BOOLEAN	0	Block of function
BLK_ALM	BOOLEAN	0	Block all the alarms
LEVEL	REAL	0.0	Level input from CB
TEMP	REAL	0.0	Temperature of the insulation medium from CB
LVL_ALM	BOOLEAN	0	Level alarm signal
LEVEL_LO	BOOLEAN	0	Level lockout signal
SET_L_LO	BOOLEAN	0	Set level lockout
SET_T_LO	BOOLEAN	0	Set temperature lockout
RESET_LO	BOOLEAN	0	Reset level and temperature lockout

Table 424: SSIML Output signals

Name	Type	Description
LEVEL	REAL	Level service value
LVL_ALM	BOOLEAN	Level below alarm level
LVL_LO	BOOLEAN	Level below lockout level
TEMP	REAL	Temperature of the insulation medium
TEMP_ALM	BOOLEAN	Temperature above alarm level
TEMP_LO	BOOLEAN	Temperature above lockout level

12.17.5 Settings

Table 425: SSIML Group settings (basic)

Name	Values (Range)	Unit	Step	Default	Description
Operation	Off On	-	-	Off	Operation Off / On
LevelAlmLimit	0.00 - 25.00	-	0.01	5.00	Alarm setting for level
LevelLOLimit	0.00 - 25.00	-	0.01	3.00	Level lockout setting
TempAlarmLimit	-40.00 - 200.00	-	0.01	30.00	Temperature alarm level setting of the medium
TempLOLimit	-40.00 - 200.00	-	0.01	30.00	Temperature lockout level of the medium
tLevelAlarm	0.000 - 60.000	s	0.001	0.000	Time delay for level alarm
tLevelLockOut	0.000 - 60.000	s	0.001	0.000	Time delay for level lockout indication
tTempAlarm	0.000 - 60.000	s	0.001	0.000	Time delay for temperature alarm
tTempLockOut	0.000 - 60.000	s	0.001	0.000	Time delay for temperture lockout
tResetLevelAlm	0.000 - 60.000	s	0.001	0.000	Reset time delay for level alarm
tResetLevelLO	0.000 - 60.000	s	0.001	0.000	Reset time delay for level lockout
tResetTempLO	0.000 - 60.000	s	0.001	0.000	Reset time delay for temperture lockout
tResetTempAlm	0.000 - 60.000	s	0.001	0.000	Reset time delay for temperture alarm

12.17.6 Operation principle

Insulation liquid monitoring function SSIML is used to monitor oil level in the circuit breaker. Two binary output signals are used from the circuit breaker to initiate alarm signals, level below alarm level and level below lockout level. If the input signal LVL_ALM is high, which indicate that the oil level in the circuit breaker is below alarm level, the output signal LVL_ALM, level below alarm level, will be initiated after a set time delay and indicate that maintenance of the circuit breaker is required. Similarly, if the input signal LVL_LO is high, which indicate oil level in the circuit breaker is below lockout level, the output signal LVL_LO, will be initiated after a time delay. The two time delay settings, *tLevelAlarm* and *tLevelLockOut*, are included in order not to initiate any alarm for short sudden changes in the oil level. If the oil level in the circuit breaker goes below the levels for more than the set time delays the corresponding signals, LVL_ALM, level below alarm level and LVL_LO, level below lockout level alarm will be obtained.

The input signal BLK_ALM is used to block the two alarms levels. The input signal BLOCK is used to block both the alarms and the function.

12.17.7 Technical data

Table 426: SSIML Technical data

Function	Range or value	Accuracy
Timers	(0.000-60.000) s	± 0.5% ± 110 ms

12.18 Circuit breaker condition monitoring SSCBR

12.18.1 Identification

Function description	IEC 61850 identification	IEC 60617 identification	ANSI/IEEE C37.2 device number
Circuit breaker condition monitoring	SSCBR	-	-

12.18.2 Functionality

The circuit breaker condition monitoring function SSCBR is used to monitor different parameters of the circuit breaker. The breaker requires maintenance when the number of operations has reached a predefined value. The energy is calculated from the measured input currents as a sum of I^2t values. Alarms are generated when the calculated values exceed the threshold settings.

The function contains a block alarm functionality.

The supervised and presented breaker functions include

- breaker open and close travel time
- spring charging time
- number of breaker operations
- accumulated I^2t per phase with alarm and lockout
- remaining breaker life per phase
- breaker inactivity

12.18.3 Function block

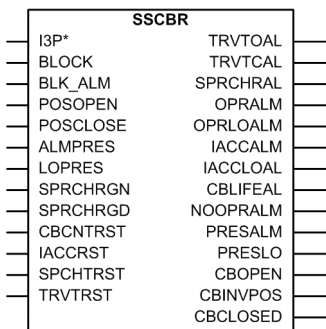

Figure 230: SSCBR function block

12.18.4 Signals

Table 427: SSCBR Input signals

Name	Type	Default	Description
I3P	GROUP SIGNAL	-	Three phase group signal for current inputs
BLOCK	BOOLEAN	0	Block of function
BLK_ALM	BOOLEAN	0	Block all the alarms
POSOPEN	BOOLEAN	0	Signal for open position of apparatus from I/O
POSCLOSE	BOOLEAN	0	Signal for close position of apparatus from I/O
ALMPRES	BOOLEAN	0	Binary pressure alarm input
LOPRES	BOOLEAN	0	Binary pressure input for lockout indication
SPRCHRGN	BOOLEAN	0	CB spring charging started input
SPRCHRGD	BOOLEAN	0	CB spring charged input
CBCNTRST	BOOLEAN	0	Reset input for CB remaining life and operation counter
IACCRST	BOOLEAN	0	Reset accumulated currents power
SPCHTRST	BOOLEAN	0	Reset spring charge time
TRVTRST	BOOLEAN	0	Reset travel time

Table 428: SSCBR Output signals

Name	Type	Description
TRVTOAL	BOOLEAN	CB open travel time exceeded set value
TRVTCAL	BOOLEAN	CB close travel time exceeded set value
SPRCHRAL	BOOLEAN	Spring charging time has crossed the set value
OPRALM	BOOLEAN	Number of CB operations exceeds alarm limit
OPRLOALM	BOOLEAN	Number of CB operations exceeds lockout limit
IACCALM	BOOLEAN	Accumulated currents power (Iyt),exceeded alarm limit
IACCLOAL	BOOLEAN	Accumulated currents power (Iyt),exceeded lockout limit
CBLIFEAL	BOOLEAN	Remaining life of CB exceeded alarm limit
NOOPRALM	BOOLEAN	CB 'not operated for long time' alarm
PRESALM	BOOLEAN	Pressure below alarm level
PRESLO	BOOLEAN	Pressure below lockout level
CBOPEN	BOOLEAN	CB is in open position
CBINVPOS	BOOLEAN	CB is in intermediate position
CBCLOSED	BOOLEAN	CB is in closed position

12.18.5 Settings

Table 429: SSCBR Non group settings (basic)

Name	Values (Range)	Unit	Step	Default	Description
Operation	Off On	-	-	On	Operation Off / On
AccDisLevel	5.00 - 500.00	A	0.01	10.00	RMS current setting below which energy accumulation stops
CurrExp	0.00 - 2.00	-	0.01	2.00	Current exponent setting for energy calculation
RatedFaultCurr	500.00 - 75000.00	A	0.01	5000.00	Rated fault current of the breaker
RatedOpCurr	100.00 - 5000.00	A	0.01	1000.00	Rated operating current of the breaker
AccCurrAlmLvl	0.00 - 20000.00	-	0.01	2500.00	Setting of alarm level for accumulated currents power
AccCurrLO	0.00 - 20000.00	-	0.01	2500.00	Lockout limit setting for accumulated currents power
DirCoef	-3.00 - -0.50	-	0.01	-1.50	Directional coefficient for CB life calculation
LifeAlmLevel	0 - 99999	-	1	5000	Alarm level for CB remaining life
OpNumRatCurr	1 - 99999	-	1	10000	Number of operations possible at rated current
OpNumFaultCurr	1 - 10000	-	1	1000	Number of operations possible at rated fault current
OpNumAlm	0 - 9999	-	1	200	Alarm limit for number of operations
OpNumLO	0 - 9999	-	1	300	Lockout limit for number of operations
tOpenAlm	0 - 200	ms	1	40	Alarm level setting for open travel time
tCloseAlm	0 - 200	ms	1	40	Alarm level setting for close travel time
OpenTimeCorr	0 - 100	ms	1	10	Correction factor for open travel time
CloseTimeCorr	0 - 100	ms	1	10	Correction factor for CB close travel time
DifTimeCorr	-10 - 10	ms	1	5	Correction factor for time difference in auxiliary and main contacts open time
tSprngChrgAlm	0.00 - 60.00	s	0.01	1.00	Setting of alarm for spring charging time
tPressAlm	0.00 - 60.00	s	0.01	0.10	Time delay for gas pressure alarm
TPressLO	0.00 - 60.00	s	0.01	0.10	Time delay for gas pressure lockout
AccEnerInitVal	0.00 - 9999.99	-	0.01	0.00	Accumulation energy initial value
CountInitVal	0 - 9999	-	1	0	Operation numbers counter initialization value
CBRemLife	0 - 9999	-	1	5000	Initial value for the CB remaining life estimates

Table continues on next page

Name	Values (Range)	Unit	Step	Default	Description
InactDayAlm	0 - 9999	Day	1	2000	Alarm limit value of the inactive days counter
InactDayInit	0 - 9999	Day	1	0	Initial value of the inactive days counter
InactHourAlm	0 - 23	Hour	1	0	Alarm time of the inactive days counter in hours

12.18.6 Monitored data

Table 430: SSCBR Monitored data

Name	Type	Values (Range)	Unit	Description
CBOTRVT	REAL	-	ms	Travel time of the CB during opening operation
CBCLTRVT	REAL	-	ms	Travel time of the CB during closing operation
SPRCHRT	REAL	-	s	The charging time of the CB spring
NO_OPR	INTEGER	-	-	Number of CB operation cycle
NOOPRDAY	INTEGER	-	-	The number of days CB has been inactive
CBLIFEL1	INTEGER	-	-	CB Remaining life phase L1
CBLIFEL2	INTEGER	-	-	CB Remaining life phase L2
CBLIFEL3	INTEGER	-	-	CB Remaining life phase L3
IACCL1	REAL	-	-	Accumulated currents power (lyt), phase L1
IACCL2	REAL	-	-	Accumulated currents power (lyt), phase L2
IACCL3	REAL	-	-	Accumulated currents power (lyt), phase L3

12.18.7 Operation principle

The circuit breaker condition monitoring function includes a number of metering and monitoring subfunctions. The functions can be enabled and disabled with the *Operation* setting. The corresponding parameter values are “On” and “Off”. The operation counters are cleared when *Operation* is set to “Off”.

The operation of the functions can be described by using a module diagram. All the modules in the diagram are explained in the next sections.

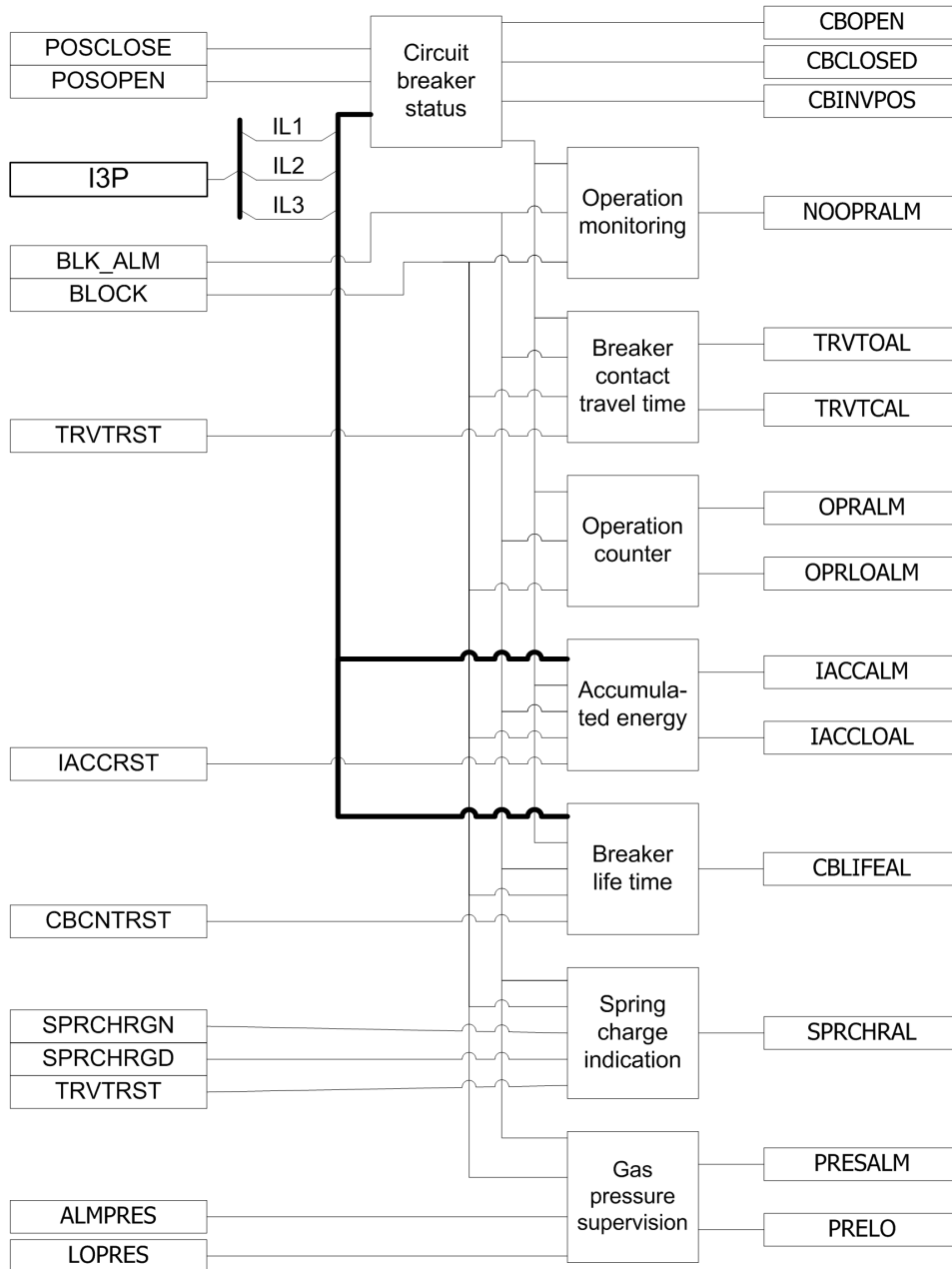

Figure 231: Functional module diagram

12.18.7.1 Circuit breaker status

The circuit breaker status subfunction monitors the position of the circuit breaker, that is, whether the breaker is in an open, closed or intermediate position. The operation of the breaker status monitoring can be described using a module diagram. All the modules in the diagram are explained in the next sections.

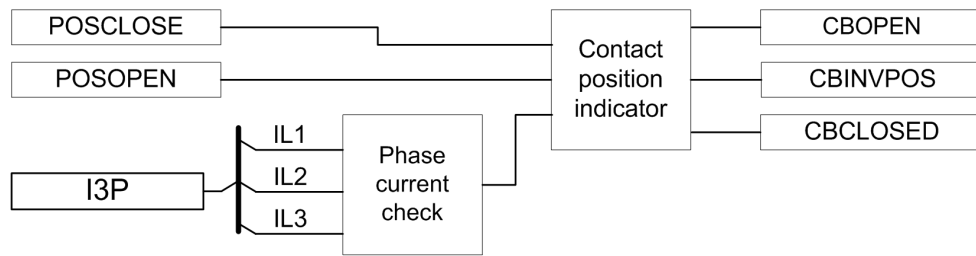

Figure 232: Functional module diagram for monitoring circuit breaker status *BLOCK* and *BLK_ALM* inputs

Phase current check

This module compares the three phase currents with the setting *AccDisLevel*. If the current in a phase exceeds the set level, information about phase is reported to the contact position indicator module.

Contact position indicator

The circuit breaker status is open if the auxiliary input contact *POSCLOSE* is low, the *POSOPEN* input is high and the current is zero. The circuit breaker is closed when the *POSOPEN* input is low and the *POSCLOSE* input is high. The breaker is in the intermediate position if both the auxiliary contacts have the same value, that is, both are in the logical level "0" or "1", or if the auxiliary input contact *POSCLOSE* is low and the *POSOPEN* input is high, but the current is not zero.

The status of the breaker is indicated with the binary outputs *CBOPEN*, *CBINVPOS* and *CBCLOSED* for open, error state and closed position respectively.

12.18.7.2 Circuit breaker operation monitoring

The purpose of the circuit breaker operation monitoring subfunction is to indicate if the circuit breaker has not been operated for a long time.

The operation of the circuit breaker operation monitoring can be described by using a module diagram. All the modules in the diagram are explained in the next sections.

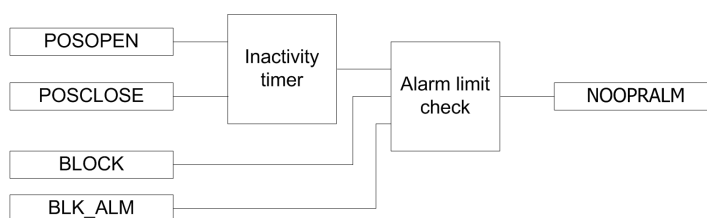

Figure 233: Functional module diagram for calculating inactive days and alarm for circuit breaker operation monitoring

Inactivity timer

The module calculates the number of days the circuit breaker has remained inactive, that is, has stayed in the same open or closed state. The calculation is done by monitoring the states of the *POSOPEN* and *POSCLOSE* auxiliary contacts.

The inactive days *NOOPRDAY* is available through the Monitored data view. It is also possible to set the initial inactive days by using the *InactDayInit* parameter.

Alarm limit check

When the inactive days exceed the limit value defined with the *InactDayAlm* setting, the NOOPRALM alarm is initiated. The time in hours at which this alarm is activated can be set with the *InactHourAlm* parameter as coordinates of UTC. The alarm signal NOOPRALM can be blocked by activating the binary input BLOCK.

12.18.7.3 Breaker contact travel time

The breaker contact travel time module calculates the breaker contact travel time for the closing and opening operation. The operation of the breaker contact travel time measurement can be described by using a module diagram. All the modules in the diagram are explained in the next sections.

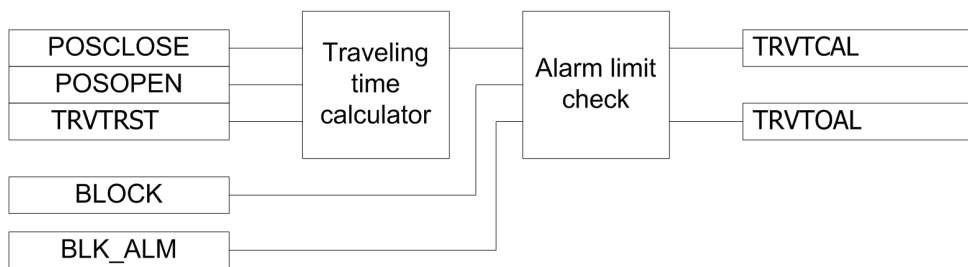
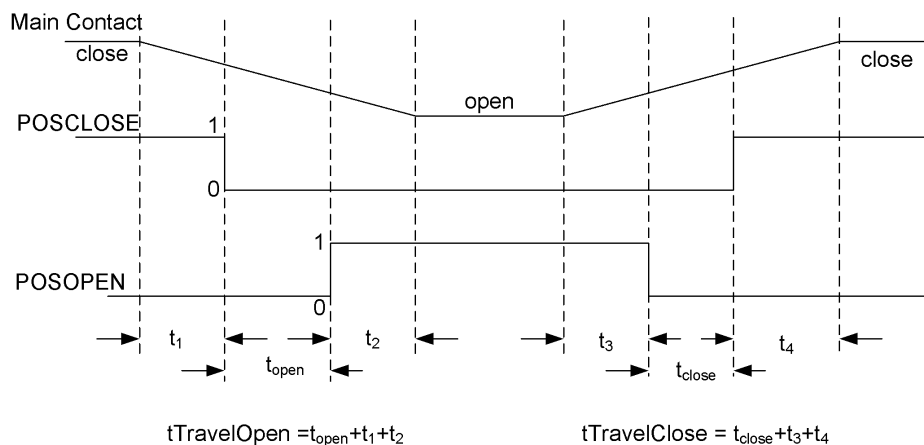

Figure 234: Functional module diagram for breaker contact travel time

Travelling time calculator

The breaker contact travel time is calculated from the time between auxiliary contacts' state change. The open travel time is measured between the opening of the POSCLOSE auxiliary contact and the closing of the POSOPEN auxiliary contact. Travel time is also measured between the opening of the POSOPEN auxiliary contact and the closing of the POSCLOSE auxiliary contact.



There is a time difference t_1 between the start of the main contact opening and the opening of the POSCLOSE auxiliary contact. Similarly, there is a time gap t_2 between the time when the POSOPEN auxiliary contact opens and the main contact is completely open. Therefore, in order to incorporate the time $t_1 + t_2$, a correction factor needs to be added with t_{open} to get the actual opening time. This factor is added with the *OpenTimeCorr* ($=t_1 + t_2$). The closing time is calculated by adding the value set with the *CloseTimeCorr* ($t_3 + t_4$) setting to the measured closing time.

The last measured opening travel time $t_{\text{TravelOpen}}$ and the closing travel time $t_{\text{TravelClose}}$ are available through the Monitored data view on the LHMI or through tools via communications.

Alarm limit check

When the measured open travel time is longer than the value set with the t_{OpenAlm} setting, the TRVTOAL output is activated. Respectively, when the measured close travel time is longer than the value set with the t_{CloseAlm} setting, the TRVTCAL output is activated.

It is also possible to block the TRVTCAL and TRVTOAL alarm signals by activating the BLOCK input.

12.18.7.4 Operation counter

The operation counter subfunction calculates the number of breaker operation cycles. Both open and close operations are included in one operation cycle. The operation counter value is updated after each open operation.

The operation of the subfunction can be described by using a module diagram. All the modules in the diagram are explained in the next sections.

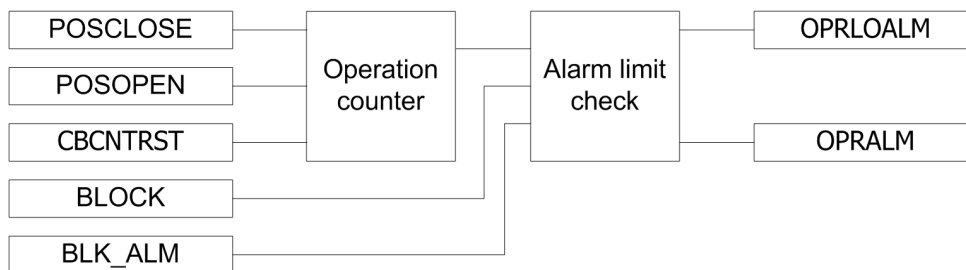

Figure 235: Functional module diagram for counting circuit breaker operations

Operation counter

The operation counter counts the number of operations based on the state change of the binary auxiliary contacts inputs POSCLOSE and POSOPEN .

The number of operations NO_OPR is available through the Monitored data view on the LHMI or through tools via communications. The old circuit breaker operation counter value can be taken into use by writing the value to the CountInitVal parameter and can be reset by *Clear CB wear* in the clear menu from LHMI.

Alarm limit check

The OPRALM operation alarm is generated when the number of operations exceeds the value set with the OpNumAlm threshold setting. However, if the number of operations increases further and exceeds the limit value set with the OpNumLO setting, the OPRLOALM output is activated.

The binary outputs OPRLOALM and OPRALM are deactivated when the BLOCK input is activated.

12.18.7.5 Accumulation of I²t

Accumulation of the I^2t module calculates the accumulated energy.

The operation of the module can be described by using a module diagram. All the modules in the diagram are explained in the next sections.

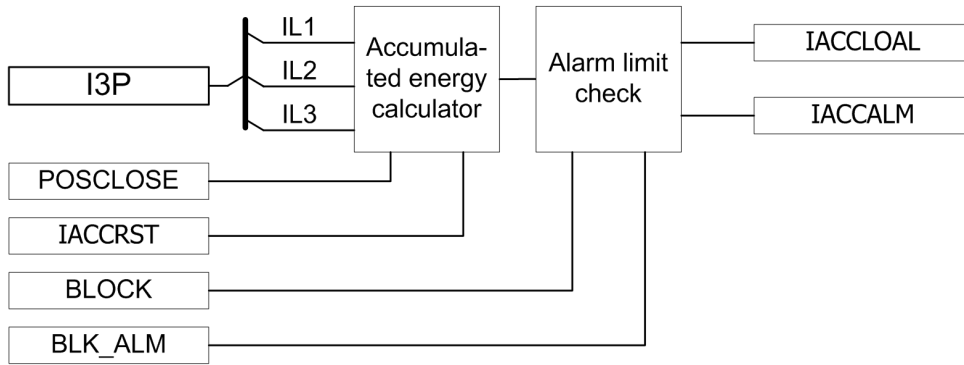

Figure 236: Functional module diagram for calculating accumulative energy and alarm

Accumulated energy calculator

This module calculates the accumulated energy I^2t [(kA)^ys]. The factor *y* is set with the *CurrExp* setting.

The calculation is initiated with the *POSCLOSE* input open events. It ends when the RMS current becomes lower than the *AccDisLevel* setting value.

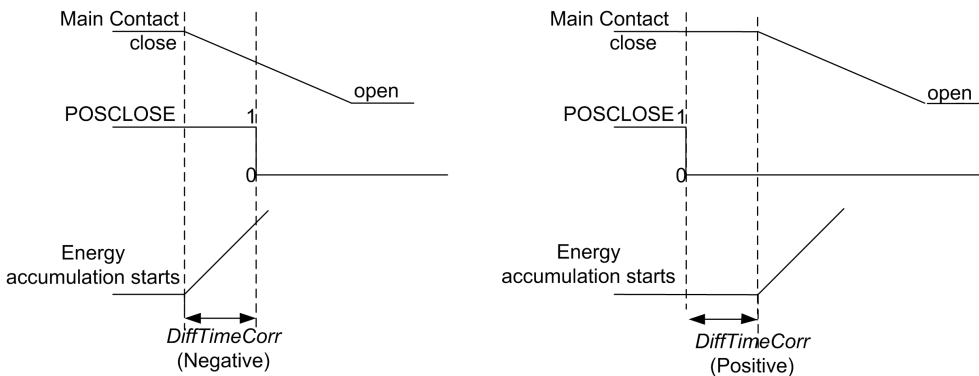

Figure 237: Significance of the *DiffTimeCorr* setting

The *DiffTimeCorr* setting is used instead of the auxiliary contact to accumulate the energy from the time the main contact opens. If the setting is positive, the calculation of energy starts after the auxiliary contact has opened and when the delay is equal to the value set with the *DiffTimeCorr* setting. When the setting is negative, the calculation starts in advance by the correction time before the auxiliary contact opens.

The accumulated energy outputs *IACCL1* (*L2*, *L3*) are available through the Monitored data view on the LHMI or through tools via communications. The values can be reset by setting the *Clear accum. breaking curr* setting to on in the clear menu from LHMI.

Alarm limit check

The *IACCALM* alarm is activated when the accumulated energy exceeds the value set with the *AccCurrAlmLv* threshold setting. However, when the energy exceeds the limit value set with the *AccCurrLO* threshold setting, the *IACCLOAL* output is activated.

The *IACCALM* and *IACCLOAL* outputs can be blocked by activating the binary input *BLOCK*.

12.18.7.6 Remaining life of the circuit breaker

Every time the breaker operates, the life of the circuit breaker reduces due to wear off. The breaker wear off depends on the tripping current. The remaining life of the breaker is

estimated from the circuit breaker trip curve provided by the manufacturer. The remaining life is decremented at least by one when the circuit breaker is opened. The operation of the remaining life of the circuit breaker subfunction can be described by using a module diagram. All the modules in the diagram are explained in the next sections.

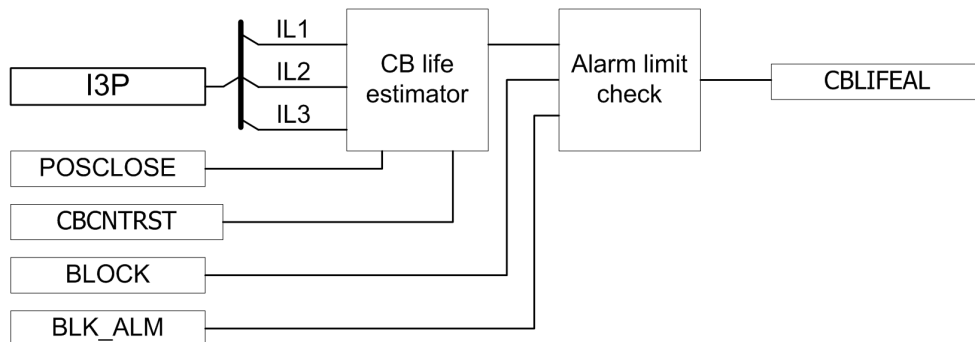

Figure 238: Functional module diagram for estimating the life of the circuit breaker

Circuit breaker life estimator

The circuit breaker life estimator module calculates the remaining life of the circuit breaker. If the tripping current is less than the rated operating current set with the *RatedOpCurr* setting, the remaining operation of the breaker reduces by one operation. If the tripping current is more than the rated fault current set with the *RatedFaultCurr* setting, then remaining operations of the circuit breaker are reduced by the *OperNoRated/OperNoFault* value. The remaining life due to the tripping current in between these two values is calculated based on the trip curve given by the manufacturer. The *OpNumRatCurr* and *OPNumFaultCurr* parameters set the number of operations the breaker can perform at the rated current and at the rated fault current, respectively.

The remaining life is calculated separately for all three phases and it is available as a monitored data value `CBLIFEAL1 (L2, L3)`. The values can be cleared by setting the parameter *CB wear values* in the clear menu from LHMI.



Clearing *CB wear values* also resets the operation counter.

Alarm limit check

When the remaining life of any phase drops below the *LifeAlmLevel* threshold setting, the corresponding circuit breaker life alarm `CBLIFEAL` is activated.

It is possible to deactivate the `CBLIFEAL` alarm signal by activating the binary input `BLOCK`. The old circuit breaker operation counter value can be taken into use by writing the value to the *Initial CB Rmn life* parameter and resetting the value via the clear menu from LHMI.

It is possible to deactivate the `CBLIFEAL` alarm signal by activating the binary input `BLOCK`.

12.18.7.7 Circuit breaker spring charged indication

The circuit breaker spring charged indication subfunction calculates the spring charging time.

The operation of the subfunction can be described by using a module diagram. All the modules in the diagram are explained in the next sections.

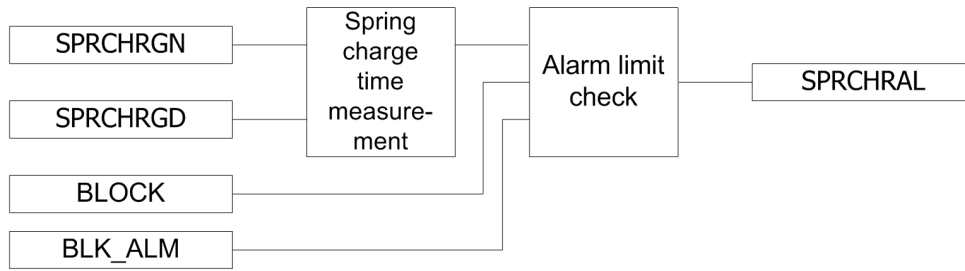

Figure 239: Functional module diagram for circuit breaker spring charged indication and alarm

Spring charge time measurement

Two binary inputs, *SPRCHRGN* and *SPRCHRGD*, indicate spring charging started and spring charged, respectively. The spring charging time is calculated from the difference of these two signal timings.

The spring charging time *SPRCHRT* is available through the Monitored data view .

Alarm limit check

If the time taken by the spring to charge is more than the value set with the *tSprngChrgAlm* setting, the subfunction generates the *SPRCHRAL* alarm.

It is possible to block the *SPRCHRAL* alarm signal by activating the *BLOCK* binary input.

12.18.7.8 Gas pressure supervision

The gas pressure supervision subfunction monitors the gas pressure inside the arc chamber.

The operation of the subfunction can be described by using a module diagram. All the modules in the diagram are explained in the next sections.

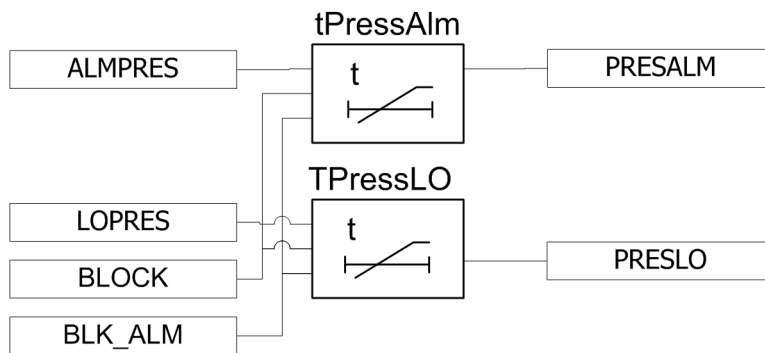

Figure 240: Functional module diagram for circuit breaker gas pressure alarm

The gas pressure is monitored through the binary input signals *LOPRES* and *ALMPRES*.

Pressure alarm time delay

When the *ALMPRES* binary input is activated, the *PRESALM* alarm is activated after a time delay set with the *tPressAlm* setting. The *PRESALM* alarm can be blocked by activating the *BLOCK* input.

If the pressure drops further to a very low level, the `LOPRES` binary input becomes high, activating the lockout alarm `PRESLO` after a time delay set with the `TPressLO` setting. The `PRESLO` alarm can be blocked by activating the `BLOCK` input.

The binary input `BLOCK` can be used to block the function. The activation of the `BLOCK` input deactivates all outputs and resets internal timers. The alarm signals from the function can be blocked by activating the binary input `BLK_ALM`.

12.18.8 Technical data

Table 431: SSCBR Technical data

Function	Range or value	Accuracy
Alarm levels for open and close travel time	(0-200) ms	$\pm 0.5\% \pm 25$ ms
Alarm levels for number of operations	(0 - 9999)	-
Setting of alarm for spring charging time	(0.00-60.00) s	$\pm 0.5\% \pm 25$ ms
Time delay for gas pressure alarm	(0.00-60.00) s	$\pm 0.5\% \pm 25$ ms
Time delay for gas pressure lockout	(0.00-60.00) s	$\pm 0.5\% \pm 25$ ms

12.19 Measurands for IEC 60870-5-103 I103MEAS

12.19.1 Functionality

103MEAS is a function block that reports all valid measuring types depending on connected signals.

The measurand reporting interval set for MMXU function blocks, using the `xDbRepInt` and `xAngDbRepInt` settings, must be coordinated with the event reporting interval set for the IEC 60870-5-103 communication using setting `CycMeasRepTime`.

CMMXU: 1					
Operation		Off			
GlobalBaseSel		1		1	6
ILDbReplnt		10	Type	1	300
ILZeroDb		500	m%	0	100000
ILHiHiLim		1200	A	0	500000
ILHiLim		1100	A	0	500000
ILLowLim		0	A	0	500000
ILLowLowLim		0	A	0	500000
ILMin		0	A	0	500000
ILMax		1300	A	0	500000
ILRepTyp		Cyclic			
ILLimHys		5,000	%	0,000	100,000
ILAngDbReplnt		10	Type	1	300
IAmpComp5		0,000	%	-10,000	10,000
IAmpComp30		0,000	%	-10,000	10,000
IAmpComp100		0,000	%	-10,000	10,000
IAngComp5		0,000	Deg	-10,000	10,000
IAngComp30		0,000	Deg	-10,000	10,000
✓ IAngComp100		0,000	Deg	-10,000	10,000

Figure 241: Settings for CMMXU: 1

All input signals to IEC 60870-5-103 I103MEAS must be connected in application configuration. Connect an input signals on IEC 60870-5-103 I103MEAS that is not connected to the corresponding output on MMXU function, to outputs on the fixed signal function block.

12.19.2 Function block

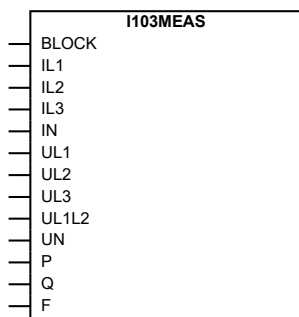

IEC10000287-1-en.vsd

Figure 242: I103MEAS function block

12.19.3 Signals

Table 432: I103MEAS Input signals

Name	Type	Default	Description
BLOCK	BOOLEAN	0	Block of service value reporting
IL1	REAL	0.0	Service value for current phase L1
IL2	REAL	0.0	Service value for current phase L2
IL3	REAL	0.0	Service value for current phase L3

Table continues on next page

Name	Type	Default	Description
IN	REAL	0.0	Service value for residual current IN
UL1	REAL	0.0	Service value for voltage phase L1
UL2	REAL	0.0	Service value for voltage phase L2
UL3	REAL	0.0	Service value for voltage phase L3
UL1L2	REAL	0.0	Service value for voltage phase-phase L1-L2
UN	REAL	0.0	Service value for residual voltage UN
P	REAL	0.0	Service value for active power
Q	REAL	0.0	Service value for reactive power
F	REAL	0.0	Service value for system frequency

12.19.4 Settings

Table 433: I103MEAS Non group settings (basic)

Name	Values (Range)	Unit	Step	Default	Description
FunctionType	1 - 255	-	1	1	Function type (1-255)
MaxIL1	1 - 99999	A	1	3000	Maximum current phase L1
MaxIL2	1 - 99999	A	1	3000	Maximum current phase L2
MaxIL3	1 - 99999	A	1	3000	Maximum current phase L3
MaxIN	1 - 99999	A	1	3000	Maximum residual current IN
MaxUL1	0.05 - 2000.00	kV	0.05	230.00	Maximum voltage for phase L1
MaxUL2	0.05 - 2000.00	kV	0.05	230.00	Maximum voltage for phase L2
MaxUL3	0.05 - 2000.00	kV	0.05	230.00	Maximum voltage for phase L3
MaxUL1-UL2	0.05 - 2000.00	kV	0.05	400.00	Maximum voltage for phase-phase L1-L2
MaxUN	0.05 - 2000.00	kV	0.05	230.00	Maximum residual voltage UN
MaxP	0.00 - 2000.00	MW	0.05	1200.00	Maximum value for active power
MaxQ	0.00 - 2000.00	MVA	0.05	1200.00	Maximum value for reactive power
MaxF	45.0 - 66.0	Hz	1.0	51.0	Maximum system frequency

12.20 Measurands user defined signals for IEC 60870-5-103 I103MEASUSR

12.20.1 Functionality

I103MEASUSR is a function block with user defined input measurands in monitor direction. These function blocks include the *FunctionType* parameter for each block in the private range, and the Information number parameter for each block.

12.20.2 Function block

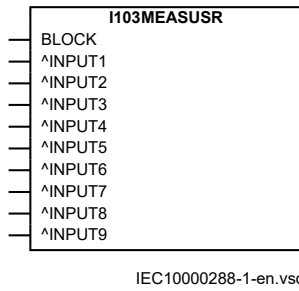

Figure 243: I103MEASUSR function block

12.20.3 Signals

Table 434: I103MEASUSR Input signals

Name	Type	Default	Description
BLOCK	BOOLEAN	0	Block of service value reporting
INPUT1	REAL	0.0	Service value for measurement on input 1
INPUT2	REAL	0.0	Service value for measurement on input 2
INPUT3	REAL	0.0	Service value for measurement on input 3
INPUT4	REAL	0.0	Service value for measurement on input 4
INPUT5	REAL	0.0	Service value for measurement on input 5
INPUT6	REAL	0.0	Service value for measurement on input 6
INPUT7	REAL	0.0	Service value for measurement on input 7
INPUT8	REAL	0.0	Service value for measurement on input 8
INPUT9	REAL	0.0	Service value for measurement on input 9

12.20.4 Settings

Table 435: I103MEASUSR Non group settings (basic)

Name	Values (Range)	Unit	Step	Default	Description
FunctionType	1 - 255	-	1	25	Function type (1-255)
InfNo	1 - 255	-	1	1	Information number for measurands (1-255)
MaxMeasur1	0.05 - 10000000000.00	-	0.05	1000.00	Maximum value for measurement on input 1
MaxMeasur2	0.05 - 10000000000.00	-	0.05	1000.00	Maximum value for measurement on input 2
MaxMeasur3	0.05 - 10000000000.00	-	0.05	1000.00	Maximum value for measurement on input 3
MaxMeasur4	0.05 - 10000000000.00	-	0.05	1000.00	Maximum value for measurement on input 4
MaxMeasur5	0.05 - 10000000000.00	-	0.05	1000.00	Maximum value for measurement on input 5

Table continues on next page

Name	Values (Range)	Unit	Step	Default	Description
MaxMeasur6	0.05 - 10000000000.00	-	0.05	1000.00	Maximum value for measurement on input 6
MaxMeasur7	0.05 - 10000000000.00	-	0.05	1000.00	Maximum value for measurement on input 7
MaxMeasur8	0.05 - 10000000000.00	-	0.05	1000.00	Maximum value for measurement on input 8
MaxMeasur9	0.05 - 10000000000.00	-	0.05	1000.00	Maximum value for measurement on input 9

12.21 Function status auto-recloser for IEC 60870-5-103 I103AR

12.21.1 Functionality

I103AR is a function block with defined functions for autorecloser indications in monitor direction. This block includes the *FunctionType* parameter, and the information number parameter is defined for each output signal.

12.21.2 Function block

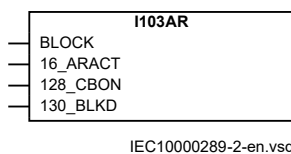

Figure 244: I103AR function block

12.21.3 Signals

Table 436: I103AR Input signals

Name	Type	Default	Description
BLOCK	BOOLEAN	0	Block of status reporting
16_ARACT	BOOLEAN	0	Information number 16, auto-recloser active
128_CBON	BOOLEAN	0	Information number 128, circuit breaker on by auto-recloser
130_BLKD	BOOLEAN	0	Information number 130, auto-recloser blocked

12.21.4 Settings

Table 437: I103AR Non group settings (basic)

Name	Values (Range)	Unit	Step	Default	Description
FunctionType	1 - 255	-	1	1	Function type (1-255)

12.22 Function status earth-fault for IEC 60870-5-103 I103EF

12.22.1 Functionality

I103EF is a function block with defined functions for earth fault indications in monitor direction. This block includes the *FunctionType* parameter, and the information number parameter is defined for each output signal.

12.22.2 Function block

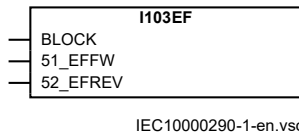

Figure 245: I103EF function block

12.22.3 Signals

Table 438: I103EF Input signals

Name	Type	Default	Description
BLOCK	BOOLEAN	0	Block of status reporting
51_EFFW	BOOLEAN	0	Information number 51, earth-fault forward
52_EFREV	BOOLEAN	0	Information number 52, earth-fault reverse

12.22.4 Settings

Table 439: I103EF Non group settings (basic)

Name	Values (Range)	Unit	Step	Default	Description
FunctionType	1 - 255	-	1	160	Function type (1-255)

12.23 Function status fault protection for IEC 60870-5-103 I103FLTPROT

12.23.1 Functionality

I103FLTPROT is used for fault indications in monitor direction. Each input on the function block is specific for a certain fault type and therefore must be connected to a correspondent signal present in the configuration. For example: 68_TRGEN represents the General Trip of the device, and therefore must be connected to the general trip signal SMPPTRC_TRIP or equivalent.

The delay observed in the protocol is the time difference in between the signal that is triggering the Disturbance Recorder and the respective configured signal to the IEC 60870-5-103 I103FLTPROT.

12.23.2 Function block

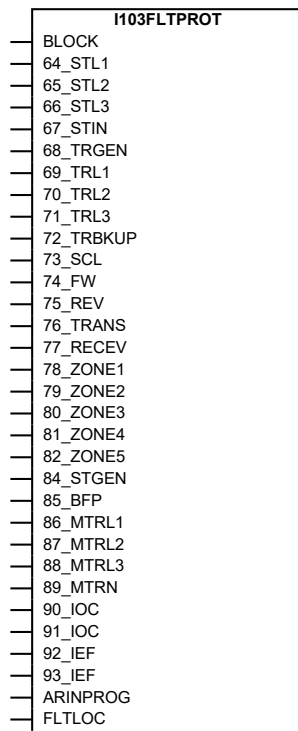

IEC10000291-1-en.vsd

Figure 246: I103FLTPROT function block

12.23.3 Signals

Table 440: I103FLTPROT Input signals

Name	Type	Default	Description
BLOCK	BOOLEAN	0	Block of status reporting.
64_STL1	BOOLEAN	0	Information number 64, start phase L1
65_STL2	BOOLEAN	0	Information number 65, start phase L2
66_STL3	BOOLEAN	0	Information number 66, start phase L3
67_STIN	BOOLEAN	0	Information number 67, start residual current IN
68_TRGEN	BOOLEAN	0	Information number 68, trip general
69_TRL1	BOOLEAN	0	Information number 69, trip phase L1
70_TRL2	BOOLEAN	0	Information number 70, trip phase L2
71_TRL3	BOOLEAN	0	Information number 71, trip phase L3
72_TRBKUP	BOOLEAN	0	Information number 72, back up trip I>>
73_SCL	REAL	0	Information number 73, fault location in ohm
74_FW	BOOLEAN	0	Information number 74, forward/line
75_REV	BOOLEAN	0	Information number 75, reverse/busbar
76_TRANS	BOOLEAN	0	Information number 76, signal transmitted
77_RECEV	BOOLEAN	0	Information number 77, signal received
78_ZONE1	BOOLEAN	0	Information number 78, zone 1

Table continues on next page

Name	Type	Default	Description
79_ZONE2	BOOLEAN	0	Information number 79, zone 2
80_ZONE3	BOOLEAN	0	Information number 80, zone 3
81_ZONE4	BOOLEAN	0	Information number 81, zone 4
82_ZONE5	BOOLEAN	0	Information number 82, zone 5
84_STGEN	BOOLEAN	0	Information number 84, start general
85_BFP	BOOLEAN	0	Information number 85, breaker failure
86_MTRL1	BOOLEAN	0	Information number 86, trip measuring system phase L1
87_MTRL2	BOOLEAN	0	Information number 87, trip measuring system phase L2
88_MTRL3	BOOLEAN	0	Information number 88, trip measuring system phase L3
89_MTRN	BOOLEAN	0	Information number 89, trip measuring system neutral N
90_IOC	BOOLEAN	0	Information number 90, over current trip, stage low
91_IOC	BOOLEAN	0	Information number 91, over current trip, stage high
92_IEF	BOOLEAN	0	Information number 92, earth-fault trip, stage low
93_IEF	BOOLEAN	0	Information number 93, earth-fault trip, stage high
ARINPROG	BOOLEAN	0	Autorecloser in progress (SMBREC- INPROGR)
FLTLOC	BOOLEAN	0	Faultlocator faultlocation valid (LMBRFLO-CALCMADE)

12.23.4 Settings

Table 441: I103FLTPROT Non group settings (basic)

Name	Values (Range)	Unit	Step	Default	Description
FunctionType	1 - 255	-	1	128	Function type (1-255)

12.24 IED status for IEC 60870-5-103 I103IED

12.24.1 Functionality

I103IED is a function block with defined IED functions in monitor direction. This block uses parameter as *FunctionType*, and information number parameter is defined for each input signal.

12.24.2 Function block

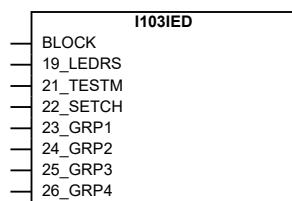

IEC10000292-2-en.vsd

Figure 247: I103IED function block

12.24.3 Signals

Table 442: I103IED Input signals

Name	Type	Default	Description
BLOCK	BOOLEAN	0	Block of status reporting
19_LEDRS	BOOLEAN	0	Information number 19, reset LEDs
21_TESTM	BOOLEAN	0	Information number 21, test mode is active
22_SETCH	BOOLEAN	0	Information number 22, setting changed
23_GRP1	BOOLEAN	0	Information number 23, setting group 1 is active
24_GRP2	BOOLEAN	0	Information number 24, setting group 2 is active
25_GRP3	BOOLEAN	0	Information number 25, setting group 3 is active
26_GRP4	BOOLEAN	0	Information number 26, setting group 4 is active

12.24.4 Settings

Table 443: I103IED Non group settings (basic)

Name	Values (Range)	Unit	Step	Default	Description
FunctionType	1 - 255	-	1	1	Function type (1-255)

12.25 Supervision status for IEC 60870-5-103 I103SUPERV

12.25.1 Functionality

I103SUPERV is a function block with defined functions for supervision indications in monitor direction. This block includes the *FunctionType* parameter, and the information number parameter is defined for each output signal.

12.25.2 Function block

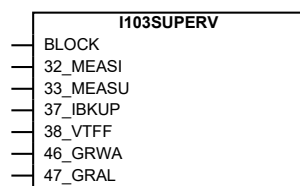

IEC10000293-1-en.vsd

Figure 248: I103SUPERV function block

12.25.3 Signals

Table 444: I103SUPERV Input signals

Name	Type	Default	Description
BLOCK	BOOLEAN	0	Block of status reporting
32_MEASI	BOOLEAN	0	Information number 32, measurand supervision of I
33_MEASU	BOOLEAN	0	Information number 33, measurand supervision of U
37_IBKUP	BOOLEAN	0	Information number 37, I high-high back-up protection
38_VTFF	BOOLEAN	0	Information number 38, fuse failure VT
46_GRWA	BOOLEAN	0	Information number 46, group warning
47_GRAL	BOOLEAN	0	Information number 47, group alarm

12.25.4 Settings

Table 445: I103SUPERV Non group settings (basic)

Name	Values (Range)	Unit	Step	Default	Description
FunctionType	1 - 255	-	1	1	Function type (1-255)

12.26 Status for user defined signals for IEC 60870-5-103 I103USRDEF

12.26.1 Functionality

I103USRDEF is a function blocks with user defined input signals in monitor direction. These function blocks include the *FunctionType* parameter for each block in the private range, and the information number parameter for each input signal.

I103USRDEF can be used, for example in mapping the INF numbers not supported directly by specific function blocks, like: INF17, INF18, INF20 or INF35. After connecting the appropriate signals to the I103USRDEF inputs, the user must also set the *InfNo_x* values in the settings.

I103USRDEF: 1					
FunctionType		5		1	255
NAME1		INPUT1			13 character[s]
InfNo_1		17		1	255
NAME2		INPUT2			13 character[s]
InfNo_2		18		1	255
NAME3		INPUT3			13 character[s]
InfNo_3		20		1	255
NAME4		INPUT4			13 character[s]
InfNo_4		35		1	255

Figure 249: IEC 60870-5-103I103USRDEF:1

12.26.2 Function block

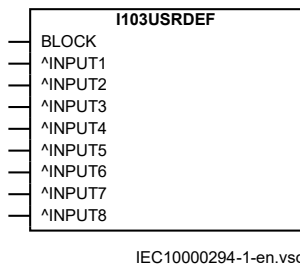

Figure 250: I103USRDEF function block

12.26.3 Signals

Table 446: I103USRDEF Input signals

Name	Type	Default	Description
BLOCK	BOOLEAN	0	Block of status reporting
INPUT1	BOOLEAN	0	Binary signal Input 1
INPUT2	BOOLEAN	0	Binary signal input 2
INPUT3	BOOLEAN	0	Binary signal input 3
INPUT4	BOOLEAN	0	Binary signal input 4
INPUT5	BOOLEAN	0	Binary signal input 5
INPUT6	BOOLEAN	0	Binary signal input 6
INPUT7	BOOLEAN	0	Binary signal input 7
INPUT8	BOOLEAN	0	Binary signal input 8

12.26.4 Settings

Table 447: I103USRDEF Non group settings (basic)

Name	Values (Range)	Unit	Step	Default	Description
FunctionType	1 - 255	-	1	5	Function type (1-255)
InfNo_1	1 - 255	-	1	1	Information number for binary input 1 (1-255)
InfNo_2	1 - 255	-	1	2	Information number for binary input 2 (1-255)
InfNo_3	1 - 255	-	1	3	Information number for binary input 3 (1-255)
InfNo_4	1 - 255	-	1	4	Information number for binary input 4 (1-255)
InfNo_5	1 - 255	-	1	5	Information number for binary input 5 (1-255)
InfNo_6	1 - 255	-	1	6	Information number for binary input 6 (1-255)
InfNo_7	1 - 255	-	1	7	Information number for binary input 7 (1-255)
InfNo_8	1 - 255	-	1	8	Information number for binary input 8 (1-255)

Section 13 Metering

13.1 Pulse counter PCGGIO

13.1.1 Identification

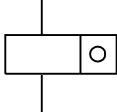
Function description	IEC 61850 identification	IEC 60617 identification	ANSI/IEEE C37.2 device number
Pulse counter	PCGGIO		-

13.1.2 Functionality

Pulse counter (PCGGIO) function counts externally generated binary pulses, for instance pulses coming from an external energy meter, for calculation of energy consumption values. The pulses are captured by the BIO (binary input/output) module and then read by the PCGGIO function. A scaled service value is available over the station bus.

13.1.3 Function block

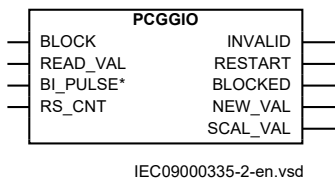

Figure 251: PCGGIO function block

13.1.4 Signals

Table 448: PCGGIO Input signals

Name	Type	Default	Description
BLOCK	BOOLEAN	0	Block of function
READ_VAL	BOOLEAN	0	Initiates an additional pulse counter reading
BI_PULSE	BOOLEAN	0	Connect binary input channel for metering
RS_CNT	BOOLEAN	0	Resets pulse counter value

Table 449: PCGGIO Output signals

Name	Type	Description
INVALID	BOOLEAN	The pulse counter value is invalid
RESTART	BOOLEAN	The reported value does not comprise a complete integration cycle
BLOCKED	BOOLEAN	The pulse counter function is blocked
NEW_VAL	BOOLEAN	A new pulse counter value is generated
SCAL_VAL	REAL	Scaled value with time and status information

13.1.5 Settings

Table 450: PCGGIO Non group settings (basic)

Name	Values (Range)	Unit	Step	Default	Description
Operation	Off On	-	-	Off	Operation Off/On
EventMask	NoEvents ReportEvents	-	-	NoEvents	Report mask for analog events from pulse counter
CountCriteria	Off RisingEdge Falling edge OnChange	-	-	RisingEdge	Pulse counter criteria
Scale	1.000 - 90000.000	-	0.001	1.000	Scaling value for SCAL_VAL output to unit per counted value
Quantity	Count ActivePower ApparentPower ReactivePower ActiveEnergy ApparentEnergy ReactiveEnergy	-	-	Count	Measured quantity for SCAL_VAL output
tReporting	1 - 3600	s	1	60	Cycle time for reporting of counter value

13.1.6 Monitored data

Table 451: PCGGIO Monitored data

Name	Type	Values (Range)	Unit	Description
CNT_VAL	INTEGER	-	-	Actual pulse counter value
SCAL_VAL	REAL	-	-	Scaled value with time and status information

13.1.7 Operation principle

The registration of pulses is done according to setting of *CountCriteria* parameter on one of the 9 binary input channels located on the BIO module. Pulse counter values are sent to the station HMI with predefined cyclicity without reset.

The reporting time period can be set in the range from 1 second to 60 minutes and is synchronized with absolute system time. Interrogation of additional pulse counter values can be done with a command (intermediate reading) for a single counter. All active counters can also be read by IEC 61850.

Pulse counter (PCGGIO) function in the IED supports unidirectional incremental counters. That means only positive values are possible. The counter uses a 32 bit format, that is, the reported value is a 32-bit, signed integer with a range 0...+2147483647. The counter value is stored in semiretain memory.

The reported value to station HMI over the station bus contains Identity, Scaled Value (pulse count x scale), Time, and Pulse Counter Quality. The Pulse Counter Quality consists of:

- Invalid (board hardware error or configuration error)
- Wrapped around
- Blocked
- Adjusted

The transmission of the counter value can be done as a service value, that is, the value frozen in the last integration cycle is read by the station HMI from the database. PCGGIO updates the value in the database when an integration cycle is finished and activates the NEW_VAL signal in the function block. This signal can be time tagged, and transmitted to the station HMI. This time corresponds to the time when the value was frozen by the function.

The BLOCK and READ_VAL inputs can be connected to logics, which are intended to be controlled either from the station HMI or/and the local HMI. As long as the BLOCK signal is set, the pulse counter is blocked. The signal connected to READ_VAL performs readings according to the setting of parameter *CountCriteria*. The signal must be a pulse with a length >1 second.

The BI_PULSE input is connected to the used input of the function block for the binary input output module (BIO).

The RS_CNT input is used for resetting the counter.

Each PCGGIO function block has four binary output signals that can be used for event recording: INVALID, RESTART, BLOCKED and NEW_VAL. These signals and the SCAL_VAL signal are accessible over IEC 61850.

The INVALID signal is a steady signal and is set if the binary input module, where the pulse counter input is located, fails or has wrong configuration.

The RESTART signal is a steady signal and is set when the reported value does not comprise a complete integration cycle. That is, in the first message after IED start-up, in the first message after deblocking, and after the counter has wrapped around during last integration cycle.

The BLOCKED signal is a steady signal and is set when the counter is blocked. There are two reasons why the counter is blocked:

- The BLOCK input is set, or
- The binary input module, where the counter input is situated, is inoperative.

The NEW_VAL signal is a pulse signal. The signal is set if the counter value was updated since last report.



Note, the pulse is short, one cycle.

The SCAL_VAL signal consists of scaled value (according to parameter *Scale*), time and status information.

13.1.8 Technical data

Table 452: PCGGIO technical data

Function	Setting range	Accuracy
Cycle time for report of counter value	(1–3600) s	-

13.2 Energy calculation and demand handling ETPMMTR

13.2.1 Identification

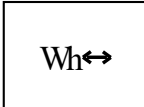
Function description	IEC 61850 identification	IEC 60617 identification	ANSI/IEEE C37.2 device number
Energy calculation and demand handling	ETPMMTR		-

13.2.2 Functionality

Outputs from the Measurements (CVMMXN) function can be used to calculate energy consumption. Active as well as reactive values are calculated in import and export direction. Values can be read or generated as pulses. Maximum demand power values are also calculated by the function.

13.2.3 Function block

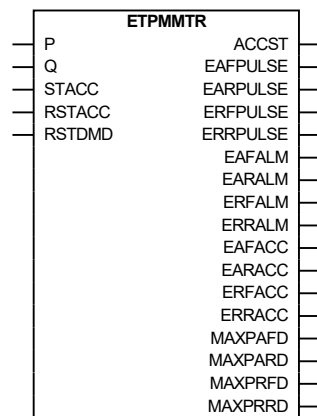

Figure 252: ETPMMTR function block

13.2.4 Signals

Table 453: ETPMMTR Input signals

Name	Type	Default	Description
P	REAL	0	Measured active power
Q	REAL	0	Measured reactive power
STACC	BOOLEAN	0	Start to accumulate energy values
RSTACC	BOOLEAN	0	Reset of accumulated energy reading
RSTDMD	BOOLEAN	0	Reset of maximum demand reading

Table 454: ETPMMTR Output signals

Name	Type	Description
ACCST	BOOLEAN	Start of accumulating energy values
EAFPULSE	BOOLEAN	Accumulated forward active energy pulse
EARPULSE	BOOLEAN	Accumulated reverse active energy pulse
ERFPULSE	BOOLEAN	Accumulated forward reactive energy pulse
ERRPULSE	BOOLEAN	Accumulated reverse reactive energy pulse
EAFALM	BOOLEAN	Alarm for active forward energy exceed limit in set interval
EARALM	BOOLEAN	Alarm for active reverse energy exceed limit in set interval
ERFALM	BOOLEAN	Alarm for reactive forward energy exceed limit in set interval
ERRALM	BOOLEAN	Alarm for reactive reverse energy exceed limit in set interval
EAFACC	REAL	Accumulated forward active energy value
EARACC	REAL	Accumulated reverse active energy value
ERFACC	REAL	Accumulated forward reactive energy value
ERRACC	REAL	Accumulated reverse reactive energy value
MAXPAFD	REAL	Maximum forward active power demand value for set interval
MAXPARD	REAL	Maximum reverse active power demand value for set interval
MAXPRFD	REAL	Maximum forward reactive power demand value for set interval
MAXPRRD	REAL	Maximum reactive power demand value in reverse direction

13.2.5 Settings

Table 455: ETPMMTR Non group settings (basic)

Name	Values (Range)	Unit	Step	Default	Description
Operation	Off On	-	-	Off	Operation Off/On
StartAcc	Off On	-	-	Off	Activate the accumulation of energy values
tEnergy	1 Minute 5 Minutes 10 Minutes 15 Minutes 30 Minutes 60 Minutes 180 Minutes	-	-	1 Minute	Time interval for energy calculation
tEnergyOnPls	0.000 - 60.000	s	0.001	1.000	Energy accumulated pulse ON time
tEnergyOffPls	0.000 - 60.000	s	0.001	0.500	Energy accumulated pulse OFF time
EAFAccPlsQty	0.001 - 10000.000	MWh	0.001	100.000	Pulse quantity for active forward accumulated energy value
EARAccPlsQty	0.001 - 10000.000	MWh	0.001	100.000	Pulse quantity for active reverse accumulated energy value
ERFAccPlsQty	0.001 - 10000.000	MVArh	0.001	100.000	Pulse quantity for reactive forward accumulated energy value
ERRAccPlsQty	0.001 - 10000.000	MVArh	0.001	100.000	Pulse quantity for reactive reverse accumulated energy value

Table 456: ETPMMTR Non group settings (advanced)

Name	Values (Range)	Unit	Step	Default	Description
EALim	0.001 - 10000000000.00 0	MWh	0.001	1000000.000	Active energy limit
ERLim	0.001 - 10000000000.00 0	MVArh	0.001	1000.000	Reactive energy limit
EnZeroClamp	Off On	-	-	On	Enable of zero point clamping detection function
LevZeroClampP	0.001 - 10000.000	MW	0.001	10.000	Zero point clamping level at active Power
LevZeroClampQ	0.001 - 10000.000	MVAr	0.001	10.000	Zero point clamping level at reactive Power
DirEnergyAct	Forward Reverse	-	-	Forward	Direction of active energy flow Forward/Reverse
DirEnergyReac	Forward Reverse	-	-	Forward	Direction of reactive energy flow Forward/Reverse
EAFPrestVal	0.000 - 10000.000	MWh	0.001	0.000	Preset Initial value for forward active energy
EARPrestVal	0.000 - 10000.000	MWh	0.001	0.000	Preset Initial value for reverse active energy
ERFPrestVal	0.000 - 10000.000	MVArh	0.001	0.000	Preset Initial value for forward reactive energy
ERRPrestVal	0.000 - 10000.000	MVArh	0.001	0.000	Preset Initial value for reverse reactive energy

13.2.6 Monitored data

Table 457: ETPMMTR Monitored data

Name	Type	Values (Range)	Unit	Description
EAFACC	REAL	-	MWh	Accumulated forward active energy value
EARACC	REAL	-	MWh	Accumulated reverse active energy value
ERFACC	REAL	-	MVArh	Accumulated forward reactive energy value
ERRACC	REAL	-	MVArh	Accumulated reverse reactive energy value
MAXPAFD	REAL	-	MW	Maximum forward active power demand value for set interval
MAXPARD	REAL	-	MW	Maximum reverse active power demand value for set interval
MAXPRFD	REAL	-	MVAr	Maximum forward reactive power demand value for set interval
MAXPRRD	REAL	-	MVAr	Maximum reactive power demand value in reverse direction

13.2.7 Operation principle

The instantaneous output values of active and reactive power from the Measurements (CVMMXN) function block are used and integrated over a selected time t_{Energy} to measure the integrated energy. The energy values (in MWh and MVArh) are available as output signals and also as pulsed output which can be connected to a pulse counter. Outputs are available for forward as well as reverse direction. The accumulated energy values can be reset from the local HMI reset menu or with input signal RSTACC.

The maximum demand values for active and reactive power are calculated for the set time interval t_{Energy} . The maximum values are updated every minute and stored in a register available over communication and from outputs MAXPAFD, MAXPARD, MAXPRFD, MAXPRRD for the active and reactive power forward and reverse direction until reset with input signal RSTDMD or from the local HMI reset menu.

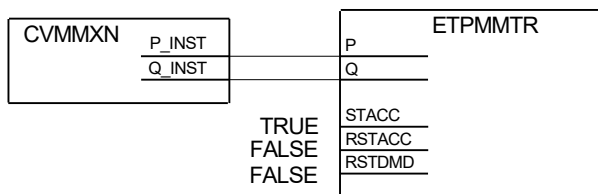

IEC09000106.vsd

Figure 253: Connection of Energy calculation and demand handling function (ETPMMTR) to the Measurements function (CVMMXN)

13.2.8 Technical data

Table 458: ETPMMTR technical data

Function	Range or value	Accuracy
Energy metering	MWh Export/Import, MVARh Export/Import	Input from MMXU. No extra error at steady load

Section 14 Station communication

14.1 DNP3 protocol

DNP3 (Distributed Network Protocol) is a set of communications protocols used to communicate data between components in process automation systems. For a detailed description of the DNP3 protocol, see the DNP3 Communication protocol manual.

14.2 IEC 61850-8-1 communication protocol

14.2.1 Identification

Function description	IEC 61850 identification	IEC 60617 identification	ANSI/IEEE C37.2 device number
IEC 61850-8-1 communication protocol	IEC 61850-8-1	-	-

14.2.2 Functionality

The IED supports the communication protocols IEC 61850-8-1 and DNP3 over TCP/IP. All operational information and controls are available through these protocols. However, some communication functions, for example, horizontal communication (GOOSE) between the IEDs, is only enabled by the IEC 61850-8-1 communication protocol.

The IED is equipped with optical Ethernet rear port(s) for the substation communication standard IEC 61850-8-1. IEC 61850-8-1 protocol allows intelligent electrical devices (IEDs) from different vendors to exchange information and simplifies system engineering. Peer-to-peer communication according to GOOSE is part of the standard. Disturbance files uploading is provided.

Disturbance files are accessed using the IEC 61850-8-1 protocol. Disturbance files are also available to any Ethernet based application via FTP in the standard Comtrade format. Further, the IED can send and receive binary values, double point values and measured values (for example from MMXU functions), together with their quality bit, using the IEC 61850-8-1 GOOSE profile. The IED meets the GOOSE performance requirements for tripping applications in substations, as defined by the IEC 61850 standard. The IED interoperates with other IEC 61850-compliant IEDs, and systems and simultaneously reports events to five different clients on the IEC 61850 station bus.

The Denial of Service functions DOSLAN1 and DOSFRNT are included to limit the inbound network traffic. The communication can thus never compromise the primary functionality of the IED.

The event system has a rate limiter to reduce CPU load. The event channel has a quota of 10 events/second after the initial 30 events/second. If the quota is exceeded the event channel transmission is blocked until the event changes is below the quota, no event is lost.

All communication connectors, except for the front port connector, are placed on integrated communication modules. The IED is connected to Ethernet-based communication systems via the fibre-optic multimode LC connector(s) (100BASE-FX).

The IED supports SNTP and IRIG-B time synchronization methods with a time-stamping accuracy of ± 1 ms.

- Ethernet based: SNTP and DNP3
- With time synchronization wiring: IRIG-B

The IED supports IEC 60870-5-103 time synchronization methods with a time stamping accuracy of ± 5 ms.

14.2.3 Communication interfaces and protocols

Table 459: Supported station communication interfaces and protocols

Protocol	Ethernet	Serial	
	100BASE-FX LC	Glass fibre (ST connector)	EIA-485
IEC 61850-8-1	•	-	-
DNP3	•	•	•
IEC 60870-5-103	-	•	•
• = Supported			

14.2.4 Settings

Table 460: IEC61850-8-1 Non group settings (basic)

Name	Values (Range)	Unit	Step	Default	Description
Operation	Off On	-	-	Off	Operation Off/On
PortSelGOOSE	Front LAN1	-	-	LAN1	Port selection for GOOSE communication
PortSelMMS	Front LAN1 Front+LAN1	-	-	LAN1	Port selection for MMS communication

14.2.5 Technical data

Table 461: Communication protocol

Function	Value
Protocol TCP/IP	Ethernet
Communication speed for the IEDs	100 Mbit/s
Protocol	IEC 61850-8-1
Communication speed for the IEDs	100BASE-FX
Protocol	DNP3.0/TCP
Communication speed for the IEDs	100BASE-FX
Protocol, serial	IEC 60870-5-103
Communication speed for the IEDs	9600 or 19200 Bd
Protocol, serial	DNP3.0
Communication speed for the IEDs	300-115200 Bd

14.3 Horizontal communication via GOOSE for interlocking

14.3.1 Identification

Function description	IEC 61850 identification	IEC 60617 identification	ANSI/IEEE C37.2 device number
Horizontal communication via GOOSE for interlocking	GOOSEINTLKR CV	-	-

14.3.2 Function block

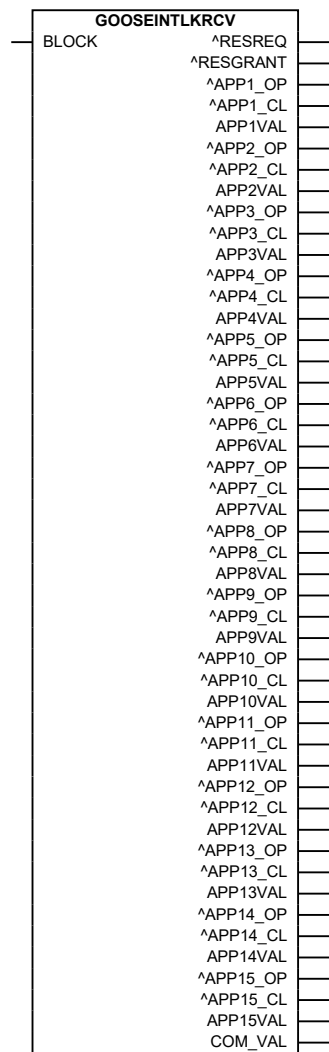

IEC09000099_1_en.vsd

Figure 254: GOOSEINTLKRCV function block

14.3.3 Signals

Table 462: GOOSEINTLKRCV Input signals

Name	Type	Default	Description
BLOCK	BOOLEAN	0	Block of output signals

Table 463: GOOSEINTLKRCV Output signals

Name	Type	Description
RESREQ	BOOLEAN	Reservation request
RESGRANT	BOOLEAN	Reservation granted
APP1_OP	BOOLEAN	Apparatus 1 position is open
APP1_CL	BOOLEAN	Apparatus 1 position is closed
APP1VAL	BOOLEAN	Apparatus 1 position is valid
APP2_OP	BOOLEAN	Apparatus 2 position is open
APP2_CL	BOOLEAN	Apparatus 2 position is closed
APP2VAL	BOOLEAN	Apparatus 2 position is valid
APP3_OP	BOOLEAN	Apparatus 3 position is open
APP3_CL	BOOLEAN	Apparatus 3 position is closed
APP3VAL	BOOLEAN	Apparatus 3 position is valid
APP4_OP	BOOLEAN	Apparatus 4 position is open
APP4_CL	BOOLEAN	Apparatus 4 position is closed
APP4VAL	BOOLEAN	Apparatus 4 position is valid
APP5_OP	BOOLEAN	Apparatus 5 position is open
APP5_CL	BOOLEAN	Apparatus 5 position is closed
APP5VAL	BOOLEAN	Apparatus 5 position is valid
APP6_OP	BOOLEAN	Apparatus 6 position is open
APP6_CL	BOOLEAN	Apparatus 6 position is closed
APP6VAL	BOOLEAN	Apparatus 6 position is valid
APP7_OP	BOOLEAN	Apparatus 7 position is open
APP7_CL	BOOLEAN	Apparatus 7 position is closed
APP7VAL	BOOLEAN	Apparatus 7 position is valid
APP8_OP	BOOLEAN	Apparatus 8 position is open
APP8_CL	BOOLEAN	Apparatus 8 position is closed
APP8VAL	BOOLEAN	Apparatus 8 position is valid
APP9_OP	BOOLEAN	Apparatus 9 position is open
APP9_CL	BOOLEAN	Apparatus 9 position is closed
APP9VAL	BOOLEAN	Apparatus 9 position is valid
APP10_OP	BOOLEAN	Apparatus 10 position is open
APP10_CL	BOOLEAN	Apparatus 10 position is closed
APP10VAL	BOOLEAN	Apparatus 10 position is valid
APP11_OP	BOOLEAN	Apparatus 11 position is open

Table continues on next page

Name	Type	Description
APP11_CL	BOOLEAN	Apparatus 11 position is closed
APP11VAL	BOOLEAN	Apparatus 11 position is valid
APP12_OP	BOOLEAN	Apparatus 12 position is open
APP12_CL	BOOLEAN	Apparatus 12 position is closed
APP12VAL	BOOLEAN	Apparatus 12 position is valid
APP13_OP	BOOLEAN	Apparatus 13 position is open
APP13_CL	BOOLEAN	Apparatus 13 position is closed
APP13VAL	BOOLEAN	Apparatus 13 position is valid
APP14_OP	BOOLEAN	Apparatus 14 position is open
APP14_CL	BOOLEAN	Apparatus 14 position is closed
APP14VAL	BOOLEAN	Apparatus 14 position is valid
APP15_OP	BOOLEAN	Apparatus 15 position is open
APP15_CL	BOOLEAN	Apparatus 15 position is closed
APP15VAL	BOOLEAN	Apparatus 15 position is valid
COM_VAL	BOOLEAN	Receive communication status is valid

14.3.4 Settings

Table 464: GOOSEINTLKRCV Non group settings (basic)

Name	Values (Range)	Unit	Step	Default	Description
Operation	Off On	-	-	Off	Operation Off/On

14.4 Goose binary receive GOOSEBINRCV

14.4.1 Identification

Function description	IEC 61850 identification	IEC 60617 identification	ANSI/IEEE C37.2 device number
Goose binary receive	GOOSEBINRCV	-	-

14.4.2 Function block

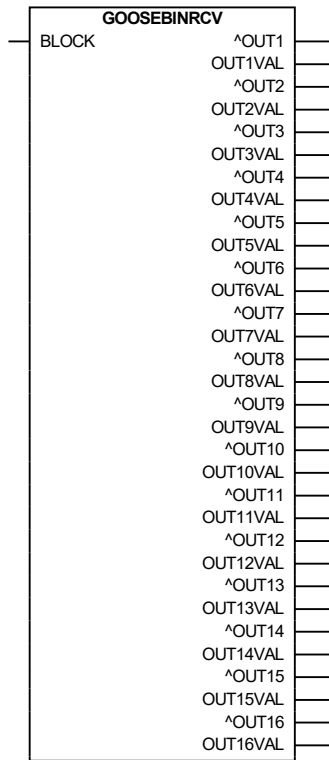

IEC09000236_en.vsd

Figure 255: GOOSEBINRCV function block

14.4.3 Signals

Table 465: GOOSEBINRCV Input signals

Name	Type	Default	Description
BLOCK	BOOLEAN	0	Block of output signals

Table 466: GOOSEBINRCV Output signals

Name	Type	Description
OUT1	BOOLEAN	Binary output 1
OUT1VAL	BOOLEAN	Valid data on binary output 1
OUT2	BOOLEAN	Binary output 2
OUT2VAL	BOOLEAN	Valid data on binary output 2
OUT3	BOOLEAN	Binary output 3
OUT3VAL	BOOLEAN	Valid data on binary output 3
OUT4	BOOLEAN	Binary output 4
OUT4VAL	BOOLEAN	Valid data on binary output 4
OUT5	BOOLEAN	Binary output 5
OUT5VAL	BOOLEAN	Valid data on binary output 5

Table continues on next page

Name	Type	Description
OUT6	BOOLEAN	Binary output 6
OUT6VAL	BOOLEAN	Valid data on binary output 6
OUT7	BOOLEAN	Binary output 7
OUT7VAL	BOOLEAN	Valid data on binary output 7
OUT8	BOOLEAN	Binary output 8
OUT8VAL	BOOLEAN	Valid data on binary output 8
OUT9	BOOLEAN	Binary output 9
OUT9VAL	BOOLEAN	Valid data on binary output 9
OUT10	BOOLEAN	Binary output 10
OUT10VAL	BOOLEAN	Valid data on binary output 10
OUT11	BOOLEAN	Binary output 11
OUT11VAL	BOOLEAN	Valid data on binary output 11
OUT12	BOOLEAN	Binary output 12
OUT12VAL	BOOLEAN	Valid data on binary output 12
OUT13	BOOLEAN	Binary output 13
OUT13VAL	BOOLEAN	Valid data on binary output 13
OUT14	BOOLEAN	Binary output 14
OUT14VAL	BOOLEAN	Valid data on binary output 14
OUT15	BOOLEAN	Binary output 15
OUT15VAL	BOOLEAN	Valid data on binary output 15
OUT16	BOOLEAN	Binary output 16
OUT16VAL	BOOLEAN	Valid data on binary output 16

14.4.4 Settings

Table 467: GOOSEBINRCV Non group settings (basic)

Name	Values (Range)	Unit	Step	Default	Description
Operation	Off On	-	-	Off	Operation Off/On

14.4.5 Operation principle

The OUTxVAL output, where $1 \leq x \leq 16$, will be HIGH if the incoming message is with valid data.

The OUTxVAL output contains both quality validity and communication validity since GOOSEBINRCV function has no COMMVALID output.



The input of this GOOSE block must be linked in SMT by means of a cross to receive the binary values.



The implementation for IEC61850 quality data handling is restricted to a simple level. If quality data validity is GOOD then the OUTxVAL output will be HIGH. If quality data validity is INVALID, QUESTIONABLE, OVERFLOW, FAILURE or OLD DATA then the OUTxVAL output will be LOW.

14.5 GOOSE function block to receive a double point value GOOSEDPRCV

14.5.1 Identification

Function description	IEC 61850 identification	IEC 60617 identification	ANSI/IEEE C37.2 device number
GOOSE function block to receive a double point value	GOOSEDPRCV	-	-

14.5.2 Functionality

GOOSEDPRCV is used to receive a double point value using IEC61850 protocol via GOOSE.

14.5.3 Function block

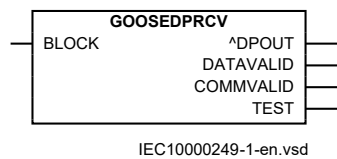

Figure 256: GOOSEDPRCV function block

14.5.4 Signals

Table 468: GOOSEDPRCV Input signals

Name	Type	Default	Description
BLOCK	BOOLEAN	0	Block of function

Table 469: GOOSEDPRCV Output signals

Name	Type	Description
DPOUT	INTEGER	Double point output
DATAVALID	BOOLEAN	Data valid for double point output
COMMVALID	BOOLEAN	Communication valid for double point output
TEST	BOOLEAN	Test output

14.5.5 Settings

Table 470: GOOSEDPRCV Non group settings (basic)

Name	Values (Range)	Unit	Step	Default	Description
Operation	Off On	-	-	Off	Operation Off/On

14.5.6 Operation principle

The DATAVALID output will be HIGH if the incoming message is with valid data.

The COMMVALID output will become LOW when the sending IED is under total failure condition and the GOOSE transmission from the sending IED does not happen.

The TEST output will go HIGH if the sending IED is in test mode.



The input of this GOOSE block must be linked in SMT by means of a cross to receive the double point values.



The implementation for IEC61850 quality data handling is restricted to a simple level. If quality data validity is GOOD then the DATAVALID output will be HIGH. If quality data validity is INVALID, QUESTIONABLE, OVERFLOW, FAILURE or OLD DATA then the DATAVALID output will be LOW.

14.6 GOOSE function block to receive an integer value GOOSEINTRCV

14.6.1 Identification

Function description	IEC 61850 identification	IEC 60617 identification	ANSI/IEEE C37.2 device number
GOOSE function block to receive an integer value	GOOSEINTRCV	-	-

14.6.2 Functionality

GOOSEINTRCV is used to receive an integer value using IEC61850 protocol via GOOSE.

14.6.3 Function block

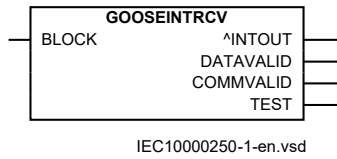

Figure 257: GOOSEINTRCV function block

14.6.4 Signals

Table 471: GOOSEINTRCV Input signals

Name	Type	Default	Description
BLOCK	BOOLEAN	0	Block of function

Table 472: GOOSEINTRCV Output signals

Name	Type	Description
INTOUT	INTEGER	Integer output
DATAVALID	BOOLEAN	Data valid for integer output
COMMVALID	BOOLEAN	Communication valid for integer output
TEST	BOOLEAN	Test output

14.6.5 Settings

Table 473: GOOSEINTRCV Non group settings (basic)

Name	Values (Range)	Unit	Step	Default	Description
Operation	Off On	-	-	Off	Operation Off/On

14.6.6 Operation principle

The DATAVALID output will be HIGH if the incoming message is with valid data.

The COMMVALID output will become LOW when the sending IED is under total failure condition and the GOOSE transmission from the sending IED does not happen.

The TEST output will go HIGH if the sending IED is in test mode.



The input of this GOOSE block must be linked in SMT by means of a cross to receive the integer values.



The implementation for IEC61850 quality data handling is restricted to a simple level. If quality data validity is GOOD then the DATAVALID output will be HIGH. If quality data validity is INVALID, QUESTIONABLE, OVERFLOW, FAILURE or OLD DATA then the DATAVALID output will be LOW.

14.7 GOOSE function block to receive a measurand value GOOSEMVRCV

14.7.1 Identification

Function description	IEC 61850 identification	IEC 60617 identification	ANSI/IEEE C37.2 device number
GOOSE function block to receive a measurand value	GOOSEMVRCV	-	-

14.7.2 Functionality

GOOSEMVRCV is used to receive measured value using IEC61850 protocol via GOOSE.

14.7.3 Function block

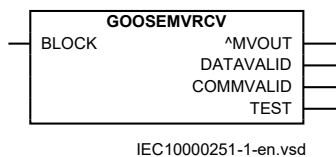

Figure 258: GOOSEMVRCV function block

14.7.4 Signals

Table 474: GOOSEMVRCV Input signals

Name	Type	Default	Description
BLOCK	BOOLEAN	0	Block of function

Table 475: GOOSEMVRCV Output signals

Name	Type	Description
MVOUT	REAL	Measurand value output
DATAVALID	BOOLEAN	Data valid for measurand value output
COMMVALID	BOOLEAN	Communication valid for measurand value output
TEST	BOOLEAN	Test output

14.7.5 Settings

Table 476: GOOSEMVRVCV Non group settings (basic)

Name	Values (Range)	Unit	Step	Default	Description
Operation	Off On	-	-	Off	Operation Off/On

14.7.6 Operation principle

The DATAVALID output will be HIGH if the incoming message is with valid data.

The COMMVALID output will become LOW when the sending IED is under total failure condition and the GOOSE transmission from the sending IED does not happen.

The TEST output will go HIGH if the sending IED is in test mode.



The input of this GOOSE block must be linked in SMT by means of a cross to receive the float values.



The implementation for IEC61850 quality data handling is restricted to a simple level. If quality data validity is GOOD then the DATAVALID output will be HIGH. If quality data validity is INVALID, QUESTIONABLE, OVERFLOW, FAILURE or OLD DATA then the DATAVALID output will be LOW.

14.8 GOOSE function block to receive a single point value GOOSESPRCV

14.8.1 Identification

Function description	IEC 61850 identification	IEC 60617 identification	ANSI/IEEE C37.2 device number
GOOSE function block to receive a single point value	GOOSESPRCV	-	-

14.8.2 Functionality

GOOSESPRCV is used to receive a single point value using IEC61850 protocol via GOOSE.

14.8.3 Function block

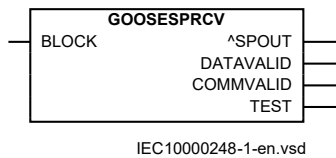

Figure 259: GOOSEPRCV function block

14.8.4 Signals

Table 477: GOOSEPRCV Input signals

Name	Type	Default	Description
BLOCK	BOOLEAN	0	Block of function

Table 478: GOOSEPRCV Output signals

Name	Type	Description
SPOUT	BOOLEAN	Single point output
DATAVALID	BOOLEAN	Data valid for single point output
COMMVALID	BOOLEAN	Communication valid for single point output
TEST	BOOLEAN	Test output

14.8.5 Settings

Table 479: GOOSEPRCV Non group settings (basic)

Name	Values (Range)	Unit	Step	Default	Description
Operation	Off On	-	-	Off	Operation Off/On

14.8.6 Operation principle

The DATAVALID output will be HIGH if the incoming message is with valid data.

The COMMVALID output will become LOW when the sending IED is under total failure condition and the GOOSE transmission from the sending IED does not happen.

The TEST output will go HIGH if the sending IED is in test mode.



The input of this GOOSE block must be linked in SMT by means of a cross to receive the binary single point values.



The implementation for IEC61850 quality data handling is restricted to a simple level. If quality data validity is GOOD then the DATAVALID output will be HIGH. If quality data validity is INVALID, QUESTIONABLE, OVERFLOW, FAILURE or OLD DATA then the DATAVALID output will be LOW.

14.9 IEC 60870-5-103 communication protocol

14.9.1 Functionality

IEC 60870-5-103 is an unbalanced (master-slave) protocol for coded-bit serial communication exchanging information with a control system, and with a data transfer rate up to 19200 bit/s. In IEC terminology, a primary station is a master and a secondary station is a slave. The communication is based on a point-to-point principle. The master must have software that can interpret IEC 60870-5-103 communication messages.

Function blocks available for the IEC 60870-5-103 protocol are described in sections Control and Monitoring. The Communication protocol manual for IEC 60870-5-103 includes the 650 series vendor specific IEC 60870-5-103 implementation.

IEC 60870-5-103 protocol can be configured to use either the optical serial or RS485 serial communication interface on the COM03 or the COM05 communication module. The functions Operation selection for optical serial OPTICALPROT and Operation selection for RS485 RS485PROT are used to select the communication interface.



See the Engineering manual for IEC103 60870-5-103 engineering procedures in PCM600.

The function IEC60870-5-103 Optical serial communication, OPTICAL103, is used to configure the communication parameters for the optical serial communication interface. The function IEC60870-5-103 serial communication for RS485, RS485103, is used to configure the communication parameters for the RS485 serial communication interface.

14.9.2 Settings

Table 480: OPTICAL103 Non group settings (basic)

Name	Values (Range)	Unit	Step	Default	Description
SlaveAddress	1 - 255	-	1	1	Slave address
BaudRate	9600 Bd 19200 Bd	-	-	9600 Bd	Baudrate on serial line
RevPolarity	Off On	-	-	On	Invert polarity
CycMeasRepTime	1.0 - 1800.0	s	0.1	5.0	Cyclic reporting time of measurments
MasterTimeDomain	UTC Local Local with DST	-	-	UTC	Master time domain

Table continues on next page

Name	Values (Range)	Unit	Step	Default	Description
TimeSyncMode	IEDTime LinMastTime IEDTimeSkew	-	-	IEDTime	Time synchronization mode
EvalTimeAccuracy	Off 5ms 10ms 20ms 40ms	-	-	5ms	Evaluate time accuracy for invalid time
EventRepMode	SeqOfEvent HiPriSpont	-	-	SeqOfEvent	Event reporting mode

Table 481: RS485103 Non group settings (basic)

Name	Values (Range)	Unit	Step	Default	Description
SlaveAddress	1 - 255	-	1	1	Slave address
BaudRate	9600 Bd 19200 Bd	-	-	9600 Bd	Baudrate on serial line
CycMeasRepTime	1.0 - 1800.0	s	0.1	5.0	Cyclic reporting time of measurments
MasterTimeDomain	UTC Local Local with DST	-	-	UTC	Master time domain
TimeSyncMode	IEDTime LinMastTime IEDTimeSkew	-	-	IEDTime	Time synchronization mode
EvalTimeAccuracy	Off 5ms 10ms 20ms 40ms	-	-	5ms	Evaluate time accuracy for invalid time
EventRepMode	SeqOfEvent HiPriSpont	-	-	SeqOfEvent	Event reporting mode

14.10 IEC 61850-8-1 redundant station bus communication

Function description	IEC 61850 identification	IEC 60617 identification	ANSI/IEEE C37.2 device number
System component for parallel redundancy protocol	PRPSTATUS	-	-

14.10.1 Functionality

Redundant station bus communication according to IEC 62439-3 Edition 2 is available as option in the Customized 650 Ver 1.3 series IEDs, and the selection is made at ordering. Redundant station bus communication according to IEC 62439-3 Edition 2 uses both ports LAN1A and LAN1B on the COM03 module.



Select COM03 for redundant station bus according to IEC 62439-3 Edition 2 protocol, at the time of ordering.
IEC 62439-3 Edition 2 is NOT compatible with IEC 62439-3 Edition 1.

14.10.2 Principle of operation

The redundant station bus communication is configured using the local HMI, **Main Menu/ Configuration/Communication/TCP-IP configuration/ETHLAN1_AB**. The settings are also visible in PST in PCM600.

The communication is performed in parallel, that is the same data package is transmitted on both channels simultaneously. The received package identity from one channel is compared with the data package identity from the other channel. If the identity is the same, the last package is discarded.

PRPSTATUS supervises redundant communication on the two channels. If no data package has been received on one or both channels within the last 10 s, the output LAN1-A and/or LAN1-B are set to indicate error.

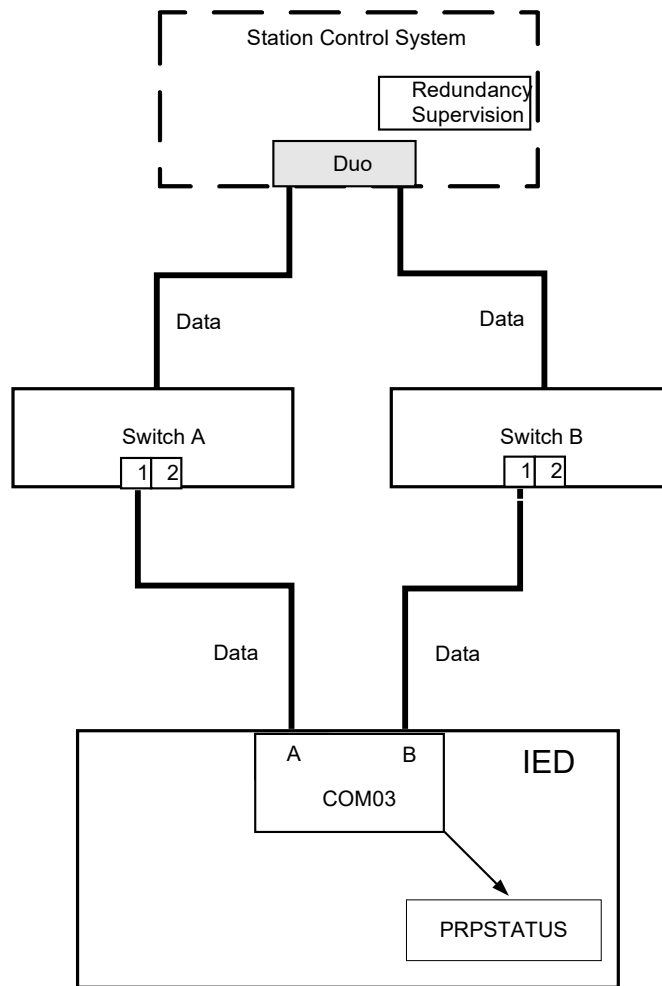

IEC13000003-1-en.vsd

Figure 260: Redundant station bus

14.10.3 Function block

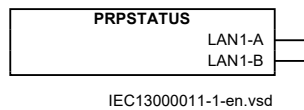

Figure 261: PRPSTATUS function block

Table 482: PRPSTATUS Output signals

Name	Type	Description
LAN1-A	BOOLEAN	LAN1 channel A status
LAN1-B	BOOLEAN	LAN1 channel B status

14.10.4 Setting parameters

The PRPSTATUS function has no user settings.

However, the redundant communication is configured in the LHMI under **Main menu/Configuration/Communication/TCP-IP configuration/ETHLAN1_AB** where *Operation mode*, *IPAddress* and *IPMask* are configured.

14.11 Activity logging parameters ACTIVLOG

14.11.1 Activity logging ACTIVLOG

ACTIVLOG contains all settings for activity logging.

There can be 6 external log servers to send syslog events to. Each server can be configured with IP address; IP port number and protocol format. The format can be either syslog (RFC 5424) or Common Event Format (CEF) from ArcSight.

14.11.2 Settings

Table 483: ACTIVLOG Non group settings (basic)

Name	Values (Range)	Unit	Step	Default	Description
ExtLogSrv1Type	Off SYSLOG UDP/IP SYSLOG TCP/IP CEF TCP/IP	-	-	Off	External log server 1 type
ExtLogSrv1Port	1 - 65535	-	1	514	External log server 1 port number
ExtLogSrv1IP	0 - 18	IP Address	1	127.0.0.1	External log server 1 IP-address
ExtLogSrv2Type	Off SYSLOG UDP/IP SYSLOG TCP/IP CEF TCP/IP	-	-	Off	External log server 2 type
ExtLogSrv2Port	1 - 65535	-	1	514	External log server 2 port number
ExtLogSrv2IP	0 - 18	IP Address	1	127.0.0.1	External log server 2 IP-address

Table continues on next page

Name	Values (Range)	Unit	Step	Default	Description
ExtLogSrv3Type	Off SYSLOG UDP/IP SYSLOG TCP/IP CEF TCP/IP	-	-	Off	External log server 3 type
ExtLogSrv3Port	1 - 65535	-	1	514	External log server 3 port number
ExtLogSrv3IP	0 - 18	IP Address	1	127.0.0.1	External log server 3 IP-address
ExtLogSrv4Type	Off SYSLOG UDP/IP SYSLOG TCP/IP CEF TCP/IP	-	-	Off	External log server 4 type
ExtLogSrv4Port	1 - 65535	-	1	514	External log server 4 port number
ExtLogSrv4IP	0 - 18	IP Address	1	127.0.0.1	External log server 4 IP-address
ExtLogSrv5Type	Off SYSLOG UDP/IP SYSLOG TCP/IP CEF TCP/IP	-	-	Off	External log server 5 type
ExtLogSrv5Port	1 - 65535	-	1	514	External log server 5 port number
ExtLogSrv5IP	0 - 18	IP Address	1	127.0.0.1	External log server 5 IP-address
ExtLogSrv6Type	Off SYSLOG UDP/IP SYSLOG TCP/IP CEF TCP/IP	-	-	Off	External log server 6 type
ExtLogSrv6Port	1 - 65535	-	1	514	External log server 6 port number
ExtLogSrv6IP	0 - 18	IP Address	1	127.0.0.1	External log server 6 IP-address

14.12 Generic security application component AGSAL

14.12.1 Generic security application AGSAL

As a logical node AGSAL is used for monitoring security violation regarding authorization, access control and inactive association including authorization failure. Therefore, all the information in AGSAL can be configured to report to 61850 client.

14.13 Security events on protocols SECALARM

14.13.1 Security alarm SECALARM

14.13.2 Signals

Table 484: SECALARM Output signals

Name	Type	Description
EVENTID	INTEGER	EventId of the generated security event
SEQNUMBER	INTEGER	Sequence number of the generated security event

14.13.3 Settings

Table 485: SECALARM Non group settings (basic)

Name	Values (Range)	Unit	Step	Default	Description
Operation	Off On	-	-	On	Operation On/Off

Section 15 Basic IED functions

15.1 Self supervision with internal event list

15.1.1 Functionality

The Self supervision with internal event list INTERRSIG and SELFSUPEVLST function reacts to internal system events generated by the different built-in self-supervision elements. The internal events are saved in an internal event list presented on the LHMI and in PCM600 event viewer tool.

15.1.2 Internal error signals INTERRSIG

15.1.2.1 Identification

Function description	IEC 61850 identification	IEC 60617 identification	ANSI/IEEE C37.2 device number
Internal error signal	INTERRSIG	-	-

15.1.2.2 Function block

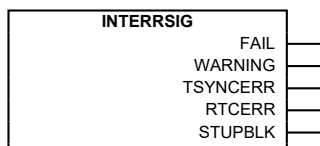

IEC09000334-2-en.vsd

Figure 262: INTERRSIG function block

15.1.2.3 Signals

Table 486: INTERRSIG Output signals

Name	Type	Description
FAIL	BOOLEAN	Internal fail
WARNING	BOOLEAN	Internal warning
TSYNCERR	BOOLEAN	Time synchronization error
RTCERR	BOOLEAN	Real time clock error
STUPBLK	BOOLEAN	Application startup block

15.1.2.4 Settings

The function does not have any settings available in Local HMI or Protection and Control IED Manager (PCM600).

15.1.3 Internal event list SELFSUPEVLST

15.1.3.1 Identification

Function description	IEC 61850 identification	IEC 60617 identification	ANSI/IEEE C37.2 device number
Internal event list	SELSUPEVLST	-	-

15.1.3.2 Settings

The function does not have any parameters available in Local HMI or Protection and Control IED Manager (PCM600).

15.1.4 Operation principle

The self-supervision operates continuously and includes:

- Normal micro-processor watchdog function.
- Checking of digitized measuring signals.
- Other alarms, for example hardware and time synchronization.

The SELFSUPEVLST function status can be monitored from the local HMI, from the Event Viewer in PCM600 or from a SMS/SCS system.

Under the Diagnostics menu in the local HMI the present information from the self-supervision function can be reviewed. The information can be found under **Main menu/Diagnostics/Internal events** or **Main menu/Diagnostics/IED status/General**. The information from the self-supervision function is also available in the Event Viewer in PCM600. Both events from the Event list and the internal events are listed in time consecutive order in the Event Viewer.

A self-supervision summary can be obtained by means of the potential free change-over alarm contact (INTERNAL FAIL) located on the power supply module. This output contact is activated (where there is no fault) and deactivated (where there is a fault) by the Internal Fail signal, see [Figure 263](#). The software watchdog timeout and the undervoltage detection of the PSM will deactivate the contact as well.

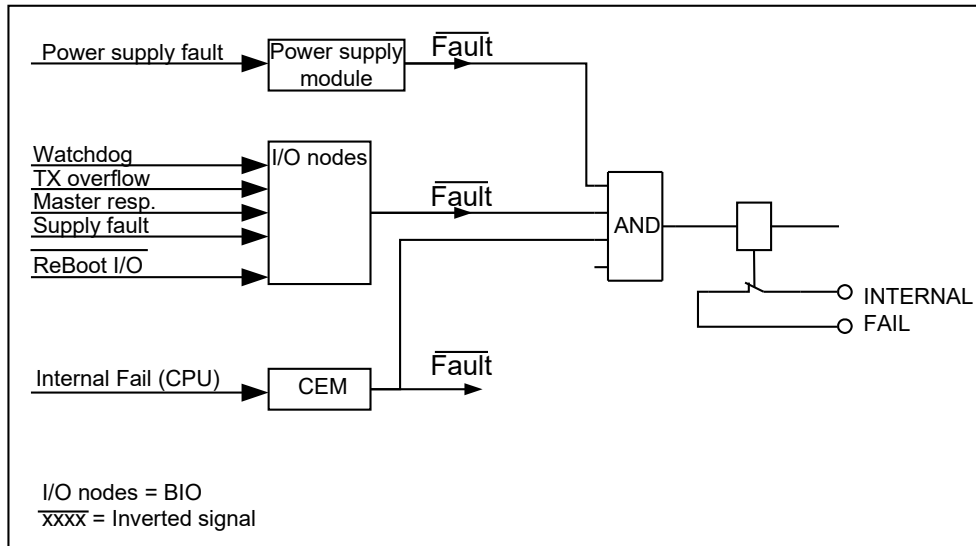

IEC09000390-1-en.vsd

Figure 263: Hardware self-supervision, potential-free contact

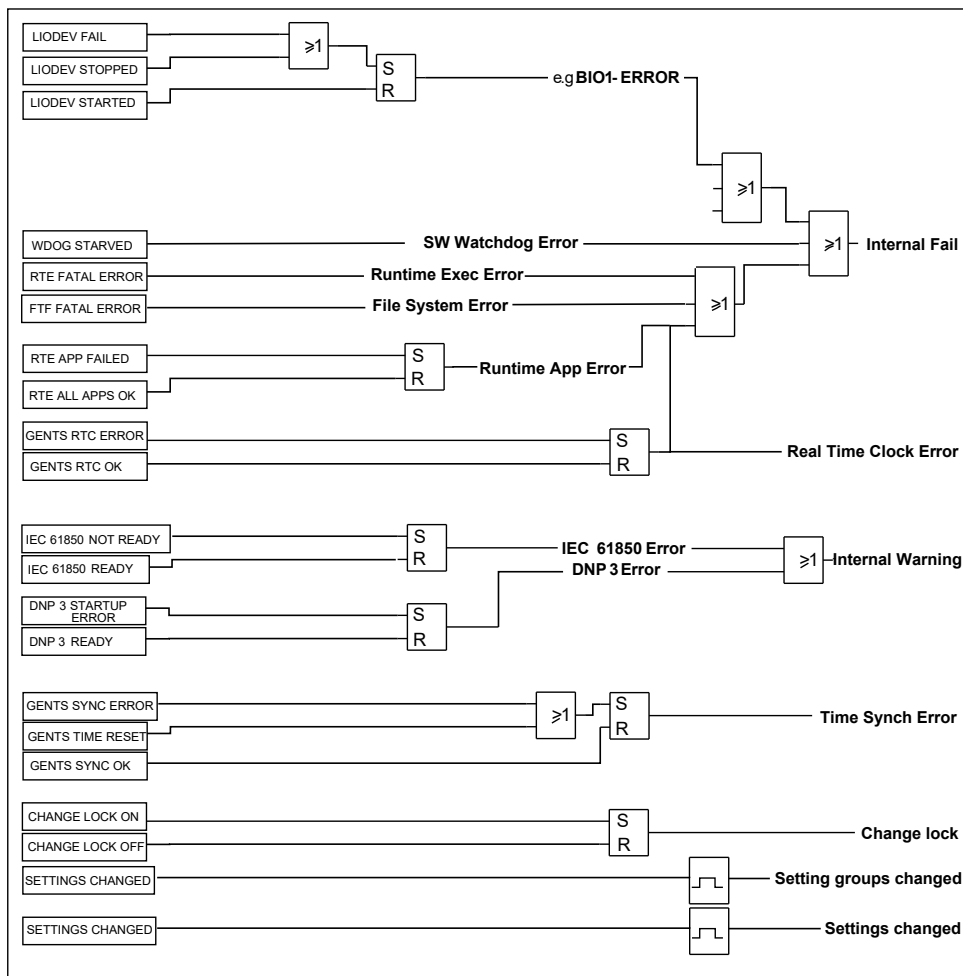

IEC09000381-2-en.vsd

Figure 264: Self supervision, function block internal signals

Some signals are available from the INTERRSIG function block. The signals from INTERRSIG function block are sent as events to the station level of the control system. The signals from the INTERRSIG function block can also be connected to binary outputs for signalization via output relays or they can be used as conditions for other functions if required/desired.

Individual error signals from I/O modules can be obtained from respective module in the Signal Matrix tool. Error signals from time synchronization can be obtained from the time synchronization block INTERRSIG.

15.1.4.1 Internal signals

SELSUPEVLST function provides several status signals, that tells about the condition of the IED. As they provide information about the internal status of the IED, they are also called internal signals. The internal signals can be divided into two groups.

- Standard signals are always presented in the IED, see [Table 487](#).
- Hardware dependent internal signals are collected depending on the hardware configuration, see [Table 488](#).

Explanations of internal signals are listed in [Table 489](#).

Table 487: SELSUPEVLST standard internal signals

Name of signal	Description
Internal Fail	Internal fail status
Internal Warning	Internal warning status
Real Time Clock Error	Real time clock status
Time Synch Error	Time synchronization status
Runtime App Error	Runtime application error status
Runtime Exec Error	Runtime execution error status
IEC61850 Error	IEC 61850 error status
SW Watchdog Error	SW watchdog error status
Setting(s) Changed	Setting(s) changed
Setting Group(s) Changed	Setting group(s) changed
Change Lock	Change lock status
File System Error	Fault tolerant file system status
DNP3 Error	DNP3 error status

Table 488: Self-supervision's hardware dependent internal signals

Card	Name of signal	Description
PSM	PSM-Error	Power supply module error status
TRM	TRM-Error	Transformer module error status
COM	COM-Error	Communication module error status
BIO	BIO-Error	Binary input/output module error status
AIM	AIM-Error	Analog input module error status

Table 489: Explanations of internal signals

Name of signal	Reasons for activation
Internal Fail	This signal will be active if one or more of the following internal signals are active; Real Time Clock Error, Runtime App Error, Runtime Exec Error, SW Watchdog Error, File System Error
Internal Warning	This signal will be active if one or more of the following internal signals are active; IEC 61850 Error, DNP3 Error
Real Time Clock Error	This signal will be active if there is a hardware error with the real time clock.
Time Synch Error	This signal will be active when the source of the time synchronization is lost, or when the time system has to make a time reset.
Runtime Exec Error	This signal will be active if the Runtime Engine failed to do some actions with the application threads. The actions can be loading of settings or parameters for components, changing of setting groups, loading or unloading of application threads.
IEC61850 Error	This signal will be active if the IEC 61850 stack did not succeed in some actions like reading IEC 61850 configuration, startup, for example.
SW Watchdog Error	This signal will be activated when the IED has been under too heavy load for at least 5 minutes. The operating systems background task is used for the measurements.
Runtime App Error	This signal will be active if one or more of the application threads are not in the state that Runtime Engine expects. The states can be CREATED, INITIALIZED, RUNNING, for example.
Setting(s) Changed	This signal will generate an internal event to the internal event list if any setting(s) is changed.
Setting Group(s) Changed	This signal will generate an internal event to the Internal Event List if any setting group(s) is changed.
Change Lock	This signal will generate an internal Event to the Internal Event List if the Change Lock status is changed
File System Error	This signal will be active if both the working file and the backup file are corrupted and cannot be recovered.
DNP3 Error	This signal will be active when DNP3 detects any configuration error during startup.

15.1.4.2 Run-time model

The analog signals to the A/D converter is internally distributed into two different converters, one with low amplification and one with high amplification, see [Figure 265](#).

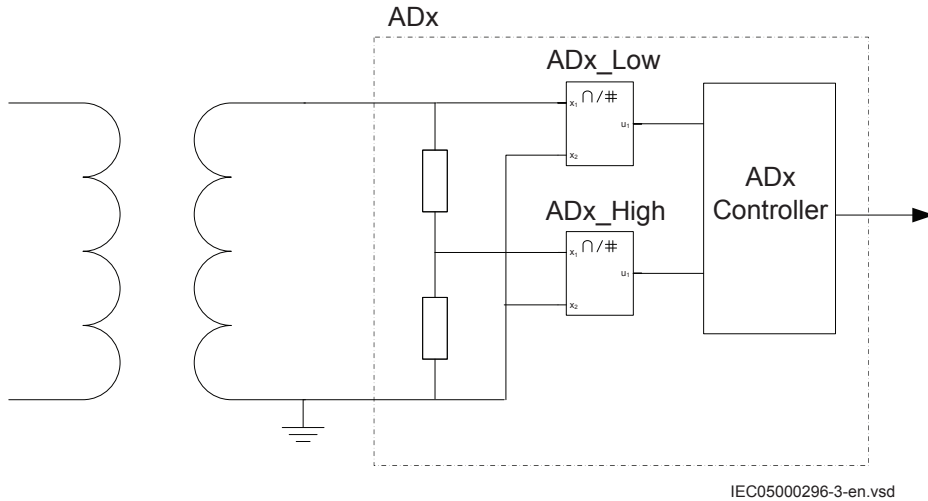

Figure 265: Simplified drawing of A/D converter for the IED.

The technique to split the analog input signal into two A/D converter(s) with different amplification makes it possible to supervise the A/D converters under normal conditions where the signals from the two A/D converters should be identical. An alarm is given if the signals are out of the boundaries. Another benefit is that it improves the dynamic performance of the A/D conversion.

The self-supervision of the A/D conversion is controlled by the ADx_Controller function. One of the tasks for the controller is to perform a validation of the input signals. The ADx_Controller function is included in all IEDs equipped with an analog input module. This is done in a validation filter which has mainly two objects: First is the validation part that checks that the A/D conversion seems to work as expected. Secondly, the filter chooses which of the two signals that shall be sent to the CPU, that is the signal that has the most suitable signal level, the *ADx_LO* or the 16 times higher *ADx_HI*.

When the signal is within measurable limits on both channels, a direct comparison of the two A/D converter channels can be performed. If the validation fails, the CPU will be informed and an alarm will be given for A/D converter failure.

The ADx_Controller also supervise other parts of the A/D converter.

15.1.5 Technical data

Table 490: Self supervision with internal event list

Data	Value
Recording manner	Continuous, event controlled
List size	40 events, first in-first out

15.2 Time synchronization

15.2.1 Functionality

The time synchronization source selector is used to select a common source of absolute time for the IED when it is a part of a control and a protection system. This makes it possible to compare event and disturbance data between all IEDs in a station automation system.



Micro SCADA OPC server should not be used as a time synchronization source.

15.2.2 Time synchronization TIMESYNCHGEN

15.2.2.1 Identification

Function description	IEC 61850 identification	IEC 60617 identification	ANSI/IEEE C37.2 device number
Time synchronization	TIMESYNCHGEN	-	-

15.2.2.2 Settings

Table 491: TIMESYNCHGEN Non group settings (basic)

Name	Values (Range)	Unit	Step	Default	Description
CoarseSyncSrc	Off SNTP DNP IEC60870-5-103	-	-	Off	Coarse time synchronization source
FineSyncSource	Off SNTP IRIG-B	-	-	Off	Fine time synchronization source
SyncMaster	Off SNTP-Server	-	-	Off	Activate IED as synchronization master

15.2.3 Time synchronization via SNTP

15.2.3.1 Identification

Function description	IEC 61850 identification	IEC 60617 identification	ANSI/IEEE C37.2 device number
Time synchronization via SNTP	SNTP	-	-

15.2.3.2 Settings

Table 492: SNTP Non group settings (basic)

Name	Values (Range)	Unit	Step	Default	Description
ServerIP-Add	0 - 255	IP Address	1	0.0.0.0	Server IP-address
RedServIP-Add	0 - 255	IP Address	1	0.0.0.0	Redundant server IP-address

15.2.4 Time system, summer time begin DSTBEGIN

15.2.4.1 Identification

Function description	IEC 61850 identification	IEC 60617 identification	ANSI/IEEE C37.2 device number
Time system, summer time begins	DSTBEGIN	-	-

15.2.4.2 Settings

Table 493: DSTBEGIN Non group settings (basic)

Name	Values (Range)	Unit	Step	Default	Description
MonthInYear	January February March April May June July August September October November December	-	-	March	Month in year when daylight time starts
DayInWeek	Sunday Monday Tuesday Wednesday Thursday Friday Saturday	-	-	Sunday	Day in week when daylight time starts
WeekInMonth	Last First Second Third Fourth	-	-	Last	Week in month when daylight time starts
UTCTimeOfDay	00:00 00:30 1:00 1:30 ... 48:00	-	-	1:00	UTC Time of day in hours when daylight time starts

15.2.5 Time system, summer time ends DSTEND

15.2.5.1 Identification

Function description	IEC 61850 identification	IEC 60617 identification	ANSI/IEEE C37.2 device number
Time system, summer time ends	DSTEND	-	-

15.2.5.2 Settings

Table 494: DSTEND Non group settings (basic)

Name	Values (Range)	Unit	Step	Default	Description
MonthInYear	January February March April May June July August September October November December	-	-	October	Month in year when daylight time ends
DayInWeek	Sunday Monday Tuesday Wednesday Thursday Friday Saturday	-	-	Sunday	Day in week when daylight time ends
WeekInMonth	Last First Second Third Fourth	-	-	Last	Week in month when daylight time ends
UTCTimeOfDay	00:00 00:30 1:00 1:30 ... 48:00	-	-	1:00	UTC Time of day in hours when daylight time ends

15.2.6 Time zone from UTC TIMEZONE

15.2.6.1 Identification

Function description	IEC 61850 identification	IEC 60617 identification	ANSI/IEEE C37.2 device number
Time zone from UTC	TIMEZONE	-	-

15.2.6.2 Settings

Table 495: TIMEZONE Non group settings (basic)

Name	Values (Range)	Unit	Step	Default	Description
NoHalfHourUTC	-24 - 24	-	1	0	Number of half-hours from UTC

15.2.7 Time synchronization via IRIG-B

15.2.7.1 Identification

Function description	IEC 61850 identification	IEC 60617 identification	ANSI/IEEE C37.2 device number
Time synchronization via IRIG-B	IRIG-B	-	-

15.2.7.2 Settings

Table 496: IRIG-B Non group settings (basic)

Name	Values (Range)	Unit	Step	Default	Description
TimeDomain	LocalTime UTC	-	-	LocalTime	Time domain
Encoding	IRIG-B 1344 1344TZ	-	-	IRIG-B	Type of encoding
TimeZoneAs1344	MinusTZ PlusTZ	-	-	PlusTZ	Time zone as in 1344 standard

15.2.8 Operation principle

15.2.8.1 General concepts

Time definitions

The error of a clock is the difference between the actual time of the clock, and the time the clock is intended to have. Clock accuracy indicates the increase in error, that is, the time gained or lost by the clock. A disciplined clock knows its own faults and tries to compensate for them.

Design of the time system (clock synchronization)

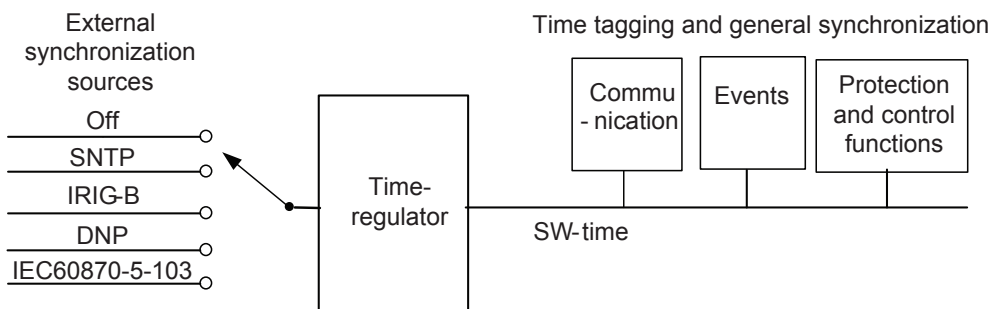

IEC09000210-2-en.vsd

Figure 266: Design of time system (clock synchronization)

Synchronization principle

From a general point of view synchronization can be seen as a hierarchical structure. A function is synchronized from a higher level and provides synchronization to lower levels.

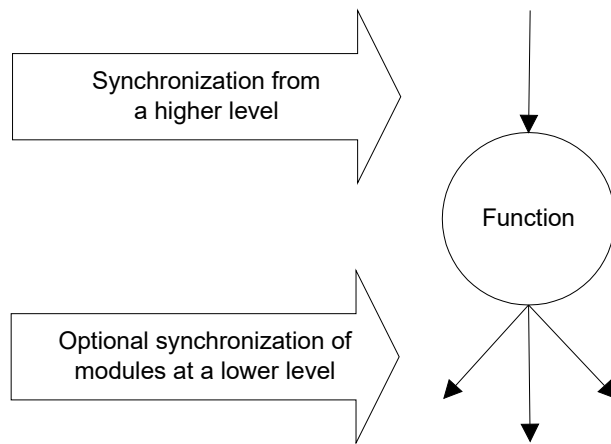

IEC09000342-1-en.vsd

Figure 267: Synchronization principle

A function is said to be synchronized when it periodically receives synchronization messages from a higher level. As the level decreases, the accuracy of the synchronization decreases as well. A function can have several potential sources of synchronization, with different maximum errors. This gives the function the possibility to choose the source with the best quality, and to adjust its internal clock after this source. The maximum error of a clock can be defined as:

- The maximum error of the last used synchronization message
- The time since the last used synchronization message
- The rate accuracy of the internal clock in the function.

15.2.8.2 Real-time clock (RTC) operation

The IED has a built-in real-time clock (RTC) with a resolution of one second. The clock has a built-in calendar that handles leap years through 2038.

Real-time clock at power off

During power off, the system time in the IED is kept by a capacitor-backed real-time clock that will provide 35 ppm accuracy for 5 days. This means that if the power is off, the time in the IED may drift with 3 seconds per day, during 5 days, and after this time the time will be lost completely.

Real-time clock at startup

At IED startup, the internal time is free running. If the RTC is still alive since the last up time, the time in the IED will be accurate (may drift 35 ppm), but if the RTC power has been lost during power off (will happen after 5 days), the IED time will start at 1970-01-01. For more information, please refer to section ["Time synchronization startup procedure"](#) and section [""](#).

Time synchronization startup procedure

Coarse time synchronization is used to set the time on the very first message and if any message has an offset of more than ten seconds. If no FineSyncSource is given, the CoarseSyncSource is used to synchronize the time.

Fine time synchronization is used to set the time on the first message after a time reset or if the source may always set the fine time, and the source gives a large offset towards the IED time. After this, the time is used to synchronize the time after a spike filter, i.e. if the source glitches momentarily or there is a momentary error, this is neglected. FineSyncSource that may always set the time is only IRIG-B.

It is not recommended to use SNTP as both fine and coarse synchronization source, as some clocks sometimes send out a bad message. For example, Arbiter clocks sometimes send out a

"zero-time message", which if SNTP is set as coarse synchronization source (with or without SNTP as fine synchronization source) leads to a jump to "2036-02-07 06:28" and back. In all cases, except for demonstration, it is recommended to use SNTP as FineSynchSource only.

Rate accuracy

In the IED, the rate accuracy at cold start is 100 ppm but if the IED is synchronized for a while, the rate accuracy is approximately 1 ppm if the surrounding temperature is constant. Normally, it takes 20 minutes to reach full accuracy.

Time-out on synchronization sources

All synchronization interfaces has a time-out and a configured interface must receive time-messages regularly in order not to give an error signal (TSYNCERR). Normally, the time-out is set so that one message can be lost without getting a TSYNCERR, but if more than one message is lost, a TSYNCERR is given.

15.2.8.3 Synchronization alternatives

Two main alternatives of external time synchronization are available. The synchronization message is applied either via any of the communication ports of the IED as a telegram message including date and time or via IRIG-B.

Synchronization via SNTP

SNTP provides a ping-pong method of synchronization. A message is sent from an IED to an SNTP server, and the SNTP server returns the message after filling in a reception time and a transmission time. SNTP operates via the normal Ethernet network that connects IEDs together in an IEC 61850 network. For SNTP to operate properly, there must be an SNTP server present, preferably in the same station. The SNTP synchronization provides an accuracy that gives +/- 1 ms accuracy for binary inputs. The IED itself can be set as an SNTP-time server.

SNTP provides complete time-information and can be used as both fine and coarse time synch source. However SNTP shall normally be used as fine synch only.

SNTP server requirements

The SNTP server to be used is connected to the local network, that is not more than 4-5 switches or routers away from the IED. The SNTP server is dedicated for its task, or at least equipped with a real-time operating system, that is not a PC with SNTP server software. The SNTP server should be stable, that is, either synchronized from a stable source like GPS, or local without synchronization. Using a local SNTP server without synchronization as primary or secondary server in a redundant configuration is not recommended.

Synchronization via IRIG-B

IRIG-B is a protocol used only for time synchronization. A clock can provide local time of the year in this format. The "B" in IRIG-B states that 100 bits per second are transmitted, and the message is sent every second. After IRIG-B there numbers stating if and how the signal is modulated and the information transmitted.

To receive IRIG-B there are one dedicated connector for the IRIG-B port. IRIG-B 00x messages can be supplied via the galvanic interface, where x (in 00x) means a number in the range of 1-7.

If the x in 00x is 4, 5, 6 or 7, the time message from IRIG-B contains information of the year. If x is 0, 1, 2 or 3, the information contains only the time within the year, and year information has to come from the tool or local HMI.

The IRIG-B input also takes care of IEEE1344 messages that are sent by IRIG-B clocks, as IRIG-B previously did not have any year information. IEEE1344 is compatible with IRIG-B and contains year information and information of the time-zone.

It is recommended to use IEEE 1344 for supplying time information to the IRIG-B module. In this case, send also the local time in the messages.

Synchronization via DNP

The DNP3 communication can be the source for the coarse time synchronization, while the fine time synchronization needs a source with higher accuracy. See the communication protocol manual for a detailed description of the DNP3 protocol.

Synchronization via IEC60870-5-103

The IEC60870-5-103 communication can be the source for the coarse time synchronization, while the fine tuning of the time synchronization needs a source with higher accuracy. See the communication protocol manual for a detailed description of the IEC60870-5-103 protocol.

15.2.9 Technical data

Table 497: Time synchronization, time tagging

Function	Value
Time tagging resolution, events and sampled measurement values	1 ms
Time tagging error with synchronization once/min (minute pulse synchronization), events and sampled measurement values	± 1.0 ms typically
Time tagging error with SNTP synchronization, sampled measurement values	± 1.0 ms typically

15.3 Parameter setting group handling**15.3.1 Functionality**

Use the four different groups of settings to optimize the IED operation for different power system conditions. Creating and switching between fine-tuned setting sets, either from the local HMI or configurable binary inputs, results in a highly adaptable IED that can be applied to a variety of power system scenarios.

15.3.2 Setting group handling SETGRPS**15.3.2.1 Identification**

Function description	IEC 61850 identification	IEC 60617 identification	ANSI/IEEE C37.2 device number
Setting group handling	SETGRPS	-	-

15.3.2.2 Settings

Table 498: SETGRPS Non group settings (basic)

Name	Values (Range)	Unit	Step	Default	Description
ActiveSetGrp	SettingGroup1 SettingGroup2 SettingGroup3 SettingGroup4	-	-	SettingGroup1	ActiveSettingGroup
MaxNoSetGrp	1 - 4	-	1	1	Max number of setting groups 1-4

15.3.3 Parameter setting groups ACTVGRP

15.3.3.1 Identification

Function description	IEC 61850 identification	IEC 60617 identification	ANSI/IEEE C37.2 device number
Parameter setting groups	ACTVGRP	-	-

15.3.3.2 Function block

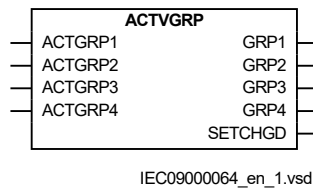

Figure 268: ACTVGRP function block

15.3.3.3 Signals

Table 499: ACTVGRP Input signals

Name	Type	Default	Description
ACTGRP1	BOOLEAN	0	Selects setting group 1 as active
ACTGRP2	BOOLEAN	0	Selects setting group 2 as active
ACTGRP3	BOOLEAN	0	Selects setting group 3 as active
ACTGRP4	BOOLEAN	0	Selects setting group 4 as active

Table 500: ACTVGRP Output signals

Name	Type	Description
GRP1	BOOLEAN	Setting group 1 is active
GRP2	BOOLEAN	Setting group 2 is active
GRP3	BOOLEAN	Setting group 3 is active
GRP4	BOOLEAN	Setting group 4 is active
SETCHGD	BOOLEAN	Pulse when setting changed

15.3.3.4 Settings

The function does not have any settings available in Local HMI or Protection and Control IED Manager (PCM600).

15.3.4 Operation principle

Parameter setting groups (ACTVGRP) function has four functional inputs, each corresponding to one of the setting groups stored in the IED. Activation of any of these inputs changes the active setting group. Five functional output signals are available for configuration purposes, so that information on the active setting group is always available.

A setting group is selected by using the local HMI, from a front connected personal computer, remotely from the station control or station monitoring system or by activating the corresponding input to the ACTVGRP function block.

Each input of the function block can be configured to connect to any of the binary inputs in the IED. To do this PCM600 must be used.

The external control signals are used for activating a suitable setting group when adaptive functionality is necessary. Input signals that should activate setting groups must be either permanent or a pulse exceeding 400 ms.

More than one input may be activated at the same time. In such cases the lower order setting group has priority. This means that if for example both group four and group two are set to be activated, group two will be the one activated.

Every time the active group is changed, the output signal SETCHGD is sending a pulse. This signal is normally connected to a SP16GGIO function block for external communication.

The parameter *MaxNoSetGrp* defines the maximum number of setting groups in use to switch between.

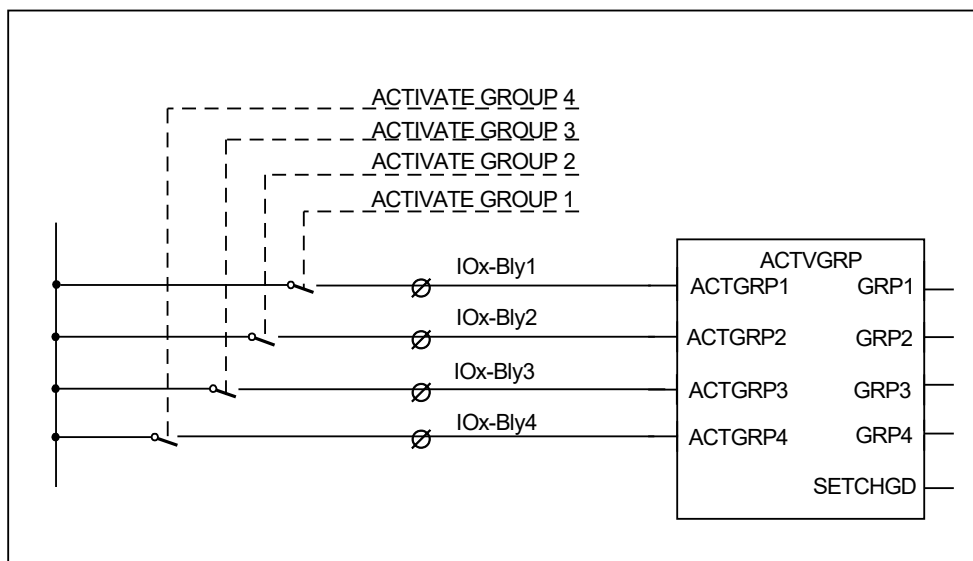

IEC09000063_en_1.vsd

Figure 269: Connection of the function to external circuits

The above example also shows the five output signals, GRP1 to 4 for confirmation of which group that is active, and the SETCHGD signal which is normally connected to a SP16GGIO function block for external communication to higher level control systems.

15.4 Test mode functionality TESTMODE

15.4.1 Identification

Function description	IEC 61850 identification	IEC 60617 identification	ANSI/IEEE C37.2 device number
Test mode functionality	TESTMODE	-	-

15.4.2 Functionality

When the Test mode functionality TESTMODE is activated, all the functions in the IED are automatically blocked. Activated TESTMODE is indicating by a flashing yellow LED on the local HMI. It is then possible to unblock every function(s) individually from the local HMI to perform required tests.

When leaving TESTMODE, all blockings are removed and the IED resumes normal operation. However, if during TESTMODE operation, power is removed and later restored, the IED will remain in TESTMODE with the same protection functions blocked or unblocked as before the power was removed. All testing will be done with actually set and configured values within the IED. No settings will be changed, thus mistakes are avoided.

Forcing of binary output signals is only possible when the IED is in test mode.

15.4.3 Function block

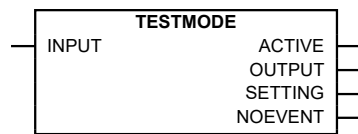

IEC09000219-1.vsd

Figure 270: TESTMODE function block

15.4.4 Signals

Table 501: TESTMODE Input signals

Name	Type	Default	Description
INPUT	BOOLEAN	0	Sets terminal in test mode when active

Table 502: TESTMODE Output signals

Name	Type	Description
ACTIVE	BOOLEAN	Terminal in test mode when active
OUTPUT	BOOLEAN	Test input is active
SETTING	BOOLEAN	Test mode setting is (On) or not (Off)
NOEVENT	BOOLEAN	Event disabled during testmode

15.4.5 Settings

Table 503: TESTMODE Non group settings (basic)

Name	Values (Range)	Unit	Step	Default	Description
TestMode	Off On	-	-	Off	Test mode in operation (On) or not (Off)
EventDisable	Off On	-	-	Off	Event disable during testmode
CmdTestBit	Off On	-	-	Off	Command bit for test required or not during testmode

15.4.6 Operation principle

Put the IED into test mode to test functions in the IED. Set the IED in test mode by

- configuration, activating the input SIGNAL on the function block TESTMODE.
- setting *TestMode* to *On* in the local HMI, under **Main menu/Tests/IED test mode/1:TESTMODE**.

While the IED is in test mode, the output ACTIVE of the function block TESTMODE is activated. The outputs of the function block TESTMODE shows the cause of the “Test mode: being in *On*” state. If the input from the configuration (OUTPUT signal is activated) or setting from local HMI (SETTING signal is activated).

While the IED is in test mode, the yellow START LED will flash and all functions are blocked. Any function can be unblocked individually regarding functionality and event signalling.

Forcing of binary output signals is only possible when the IED is in test mode.

Most of the functions in the IED can individually be blocked by means of settings from the local HMI. To enable these blockings the IED must be set in test mode (output ACTIVE is activated). When leaving the test mode, and returning to normal operation, these blockings are disabled and everything is set back to normal operation. All testing will be done with actually set and configured parameter values within the IED. No settings will be changed, thus no mistakes are possible.

The blocked functions will still be blocked next time entering the test mode, if the blockings were not reset. The released function will return to blocked state if test mode is set to off.

The blocking of a function concerns all output signals from the actual function, so no outputs will be activated.



When a binary input is used to set the IED in test mode and a parameter, that requires restart of the application, is changed, the IED will re-enter test mode and all functions will be blocked, also functions that were unblocked before the change. During the re-entering to test mode, all functions will be temporarily unblocked for a short time, which might lead to unwanted operations. This is only valid if the IED is set in TEST mode by a binary input, not by local HMI.

The TESTMODE function block might be used to automatically block functions when a test handle is inserted in a test switch. A contact in the test switch (RTXP24 contact 29-30) can supply a binary input which in turn is configured to the TESTMODE function block.

Each of the functions includes the blocking from the TESTMODE function block.

The functions can also be blocked from sending events over IEC 61850 station bus to prevent filling station and SCADA databases with test events, for example during a commissioning or maintenance test.

15.5 Change lock function CHNGLCK

15.5.1 Identification

Function description	IEC 61850 identification	IEC 60617 identification	ANSI/IEEE C37.2 device number
Change lock function	CHNGLCK	-	-

15.5.2 Functionality

Change lock function CHNGLCK is used to block further changes to the IED configuration and settings once the commissioning is complete. The purpose is to block inadvertent IED configuration changes beyond a certain point in time.

The change lock function activation is normally connected to a binary input.

When CHNGLCK has a logical one on its input, then all attempts to modify the IED configuration and setting will be denied and the message "Error: Changes blocked" will be displayed on the local HMI; in PCM600 the message will be "Operation denied by active ChangeLock". The CHNGLCK function should be configured so that it is controlled by a signal from a binary input card. This guarantees that by setting that signal to a logical zero, CHNGLCK is deactivated. If any logic is included in the signal path to the CHNGLCK input, that logic must be designed so that it cannot permanently issue a logical one to the CHNGLCK input. If such a situation would occur in spite of these precautions, then please contact the local ABB representative for remedial action.

15.5.3 Function block

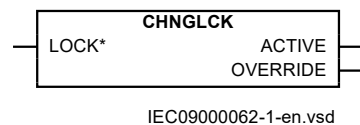

Figure 271: CHNGLCK function block

15.5.4 Signals

Table 504: CHNGLCK Input signals

Name	Type	Default	Description
LOCK	BOOLEAN	0	Activate change lock

Table 505: CHNGLCK Output signals

Name	Type	Description
ACTIVE	BOOLEAN	Change lock active
OVERRIDE	BOOLEAN	Change lock override

15.5.5 Settings

The function does not have any parameters available in Local HMI or Protection and Control IED Manager (PCM600)

15.5.6 Operation principle

The Change lock function (CHNGLCK) is configured using ACT.

The function, when activated, will still allow the following changes of the IED state that does not involve reconfiguring of the IED:

- Monitoring
- Reading events
- Resetting events
- Reading disturbance data
- Clear disturbances
- Reset LEDs
- Reset counters and other runtime component states
- Control operations
- Set system time
- Enter and exit from test mode
- Change of active setting group

The binary input signal LOCK controlling the function is defined in ACT or SMT:

Binary input	Function
1	Activated
0	Deactivated

15.6 IED identifiers TERMINALID

15.6.1 Identification

Function description	IEC 61850 identification	IEC 60617 identification	ANSI/IEEE C37.2 device number
IED identifiers	TERMINALID	-	-

15.6.2 Functionality

IED identifiers (TERMINALID) function allows the user to identify the individual IED in the system, not only in the substation, but in a whole region or a country.



Use only characters A-Z, a-z and 0-9 in station, object and unit names.

15.6.3 Settings

Table 506: TERMINALID Non group settings (basic)

Name	Values (Range)	Unit	Step	Default	Description
StationName	0 - 18	-	1	Station name	Station name
StationNumber	0 - 99999	-	1	0	Station number
ObjectName	0 - 18	-	1	Object name	Object name
ObjectNumber	0 - 99999	-	1	0	Object number
UnitName	0 - 18	-	1	Unit name	Unit name
UnitNumber	0 - 99999	-	1	0	Unit number
IEDMainFunType	0 - 255	-	1	0	IED main function type for IEC60870-5-103
TechnicalKey	0 - 18	-	1	AA0J0Q0A0	Technical key

15.7 Product information

15.7.1 Identification

Function description	IEC 61850 identification	IEC 60617 identification	ANSI/IEEE C37.2 device number
Product information	PRODINF	-	-

15.7.2 Functionality

The Product identifiers function identifies the IED. The function has seven pre-set, settings that are unchangeable but nevertheless very important:

- IEDProdType
- ProductVer
- ProductDef
- SerialNo
- OrderingNo
- ProductionDate

The settings are visible on the local HMI , under **Main menu/Diagnostics/IED status/Product identifiers**

They are very helpful in case of support process (such as repair or maintenance).

15.7.3 Settings

The function does not have any parameters available in the local HMI or PCM600.

15.8 Primary system values PRIMVAL

15.8.1 Identification

Function description	IEC 61850 identification	IEC 60617 identification	ANSI/IEEE C37.2 device number
Primary system values	PRIMVAL	-	-

15.8.2 Functionality

The rated system frequency and phasor rotation are set under **Main menu/Configuration/Power system/ Primary values/PRIMVAL** in the local HMI and PCM600 parameter setting tree.

15.8.3 Settings

Table 507: PRIMVAL Non group settings (basic)

Name	Values (Range)	Unit	Step	Default	Description
Frequency	50.0 - 60.0	Hz	10.0	50.0	Rated system frequency
PhaseRotation	Normal=L1L2L3 Inverse=L3L2L1	-	-	Normal=L1L2L3	System phase rotation

15.9 Signal matrix for analog inputs SMAI

15.9.1 Functionality

Signal matrix for analog inputs function (SMAI), also known as the preprocessor function, processes the analog signals connected to it and gives information about all aspects of the analog signals connected, like the RMS value, phase angle, frequency, harmonic content, sequence components and so on. This information is then used by the respective functions in ACT (for example protection, measurement or monitoring).

The SMAI function is used within PCM600 in direct relation with the Signal Matrix tool or the Application Configuration tool.



The SMAI function blocks for the 650 series of products are possible to set for two cycle times either 5 or 20ms. The function blocks connected to a SMAI function block shall always have the same cycle time as the SMAI block.

15.9.2 Identification

Function description	IEC 61850 identification	IEC 60617 identification	ANSI/IEEE C37.2 device number
Signal matrix for analog inputs	SMAI_20_x	-	-

15.9.3 Function block

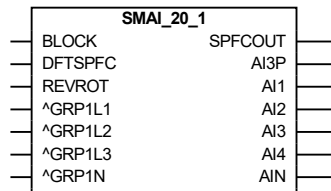

IEC09000137-1-en.vsd

Figure 272: SMAI_20_1 function block

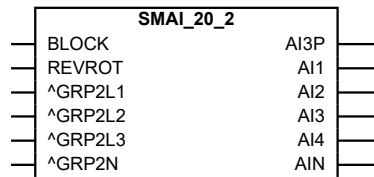

IEC09000138-2-en.vsd

Figure 273: SMAI_20_2 to SMAI_20_12 function block



Note that input and output signals on SMAI_20_2 to SMAI_20_12 are the same except for input signals GRPxL1 to GRPxN where x is equal to instance number (2 to 12).

15.9.4 Signals

Table 508: SMAI_20_1 Input signals

Name	Type	Default	Description
BLOCK	BOOLEAN	0	Block group 1
DFTSPFC	REAL	20.0	Number of samples per fundamental cycle used for DFT calculation
REVROT	BOOLEAN	0	Reverse rotation group 1
GRP1L1	STRING	-	First analog input used for phase L1 or L1-L2 quantity
GRP1L2	STRING	-	Second analog input used for phase L2 or L2-L3 quantity
GRP1L3	STRING	-	Third analog input used for phase L3 or L3-L1 quantity
GRP1N	STRING	-	Fourth analog input used for residual or neutral quantity

Table 509: SMAI_20_1 Output signals

Name	Type	Description
SPFCOUT	REAL	Number of samples per fundamental cycle from internal DFT reference function
AI3P	GROUP SIGNAL	Grouped three phase signal containing data from inputs 1-4
AI1	GROUP SIGNAL	Quantity connected to the first analog input
AI2	GROUP SIGNAL	Quantity connected to the second analog input
AI3	GROUP SIGNAL	Quantity connected to the third analog input
AI4	GROUP SIGNAL	Quantity connected to the fourth analog input
AIN	GROUP SIGNAL	Calculated residual quantity if inputs 1-3 are connected

Table 510: SMAI_20_12 Input signals

Name	Type	Default	Description
BLOCK	BOOLEAN	0	Block group 12
REVROT	BOOLEAN	0	Reverse rotation group 12
GRP12L1	STRING	-	First analog input used for phase L1 or L1-L2 quantity
GRP12L2	STRING	-	Second analog input used for phase L2 or L2-L3 quantity
GRP12L3	STRING	-	Third analog input used for phase L3 or L3-L1 quantity
GRP12N	STRING	-	Fourth analog input used for residual or neutral quantity

Table 511: SMAI_20_12 Output signals

Name	Type	Description
AI3P	GROUP SIGNAL	Grouped three phase signal containing data from inputs 1-4
AI1	GROUP SIGNAL	Quantity connected to the first analog input
AI2	GROUP SIGNAL	Quantity connected to the second analog input
AI3	GROUP SIGNAL	Quantity connected to the third analog input
AI4	GROUP SIGNAL	Quantity connected to the fourth analog input
AIN	GROUP SIGNAL	Calculated residual quantity if inputs 1-3 are connected

15.9.5 Settings

Table 512: SMAI_20_1 Non group settings (basic)

Name	Values (Range)	Unit	Step	Default	Description
GlobalBaseSel	1 - 6	-	1	1	Selection of one of the Global Base Value groups
DFTRefExtOut	InternalDFTRef DFTRefGrp1 DFTRefGrp2 DFTRefGrp3 DFTRefGrp4 DFTRefGrp5 DFTRefGrp6 DFTRefGrp7 DFTRefGrp8 DFTRefGrp9 DFTRefGrp10 DFTRefGrp11 DFTRefGrp12 External DFT ref	-	-	InternalDFTRef	DFT reference for external output
DFTReference	InternalDFTRef DFTRefGrp1 DFTRefGrp2 DFTRefGrp3 DFTRefGrp4 DFTRefGrp5 DFTRefGrp6 DFTRefGrp7 DFTRefGrp8 DFTRefGrp9 DFTRefGrp10 DFTRefGrp11 DFTRefGrp12 External DFT ref	-	-	InternalDFTRef	DFT reference
ConnectionType	Ph-N Ph-Ph	-	-	Ph-N	Input connection type
AnalogInputType	Voltage Current	-	-	Voltage	Analog input signal type

Table 513: SMAI_20_1 Non group settings (advanced)

Name	Values (Range)	Unit	Step	Default	Description
Negation	Off NegateN Negate3Ph Negate3Ph+N	-	-	Off	Negation
MinValFreqMeas	5 - 200	%	1	10	Limit for frequency calculation in % of UBase



Even if the *AnalogInputType* setting of a SMAI block is set to *Current*, the *MinValFreqMeas* setting is still visible. This means that the minimum level for current amplitude is based on *UBase*. For example, if *UBase* is 20000, the minimum amplitude for current is $20000 * 10\% = 2000$. This has practical affect only if the current measuring SMAI is used as a frequency reference for the adaptive DFT. This is not recommended, see the Setting guidelines.

Table 514: SMAI_20_12 Non group settings (basic)

Name	Values (Range)	Unit	Step	Default	Description
GlobalBaseSel	1 - 6	-	1	1	Selection of one of the Global Base Value groups
DFTReference	InternalDFTRef DFTRefGrp1 DFTRefGrp2 DFTRefGrp3 DFTRefGrp4 DFTRefGrp5 DFTRefGrp6 DFTRefGrp7 DFTRefGrp8 DFTRefGrp9 DFTRefGrp10 DFTRefGrp11 DFTRefGrp12 External DFT ref	-	-	InternalDFTRef	DFT reference
ConnectionType	Ph-N Ph-Ph	-	-	Ph-N	Input connection type
AnalogInputType	Voltage Current	-	-	Voltage	Analog input signal type

Table 515: SMAI_20_12 Non group settings (advanced)

Name	Values (Range)	Unit	Step	Default	Description
Negation	Off NegateN Negate3Ph Negate3Ph+N	-	-	Off	Negation
MinValFreqMeas	5 - 200	%	1	10	Limit for frequency calculation in % of UBase



Even if the *AnalogInputType* setting of a SMAI block is set to *Current*, the *MinValFreqMeas* setting is still visible. This means that the minimum level for current amplitude is based on *UBase*. For example, if *UBase* is 20000, the minimum amplitude for current is $20000 * 10\% = 2000$. This has practical affect only if the current measuring SMAI is used as a frequency reference for the adaptive DFT. This is not recommended, see the Setting guidelines.

15.9.6 Operation principle

Every SMAI can receive four analog signals (three phases and one neutral value), either voltage or current. The *AnalogInputType* setting should be set according to the input connected. The signal received by SMAI is processed internally and in total 244 different electrical parameters are obtained for example RMS value, peak-to-peak, frequency and so on. The activation of BLOCK input resets all outputs to 0.

SMAI_20 does all the calculation based on nominal 20 samples per line frequency period, this gives a sample frequency of 1 kHz at 50 Hz nominal line frequency and 1.2 kHz at 60 Hz nominal line frequency.

The output signals $AI1...AI4$ in SMAI_20_x function block are direct outputs of the connected input signals $GRPXL1$, $GRPXL2$, $GRPXL3$ and $GRPXM$. $GRPXM$ is always the neutral current. If $GRPXM$ is not connected, the output $AI4$ is zero. The AIN output is the calculated residual quantity, obtained as a sum of inputs $GRPXL1$, $GRPXL2$ and $GRPXL3$ but is equal to output $AI4$ if $GRPXM$ is connected. The outputs signal $AI1$, $AI2$, $AI3$ and AIN are normally connected to the analog disturbance recorder.



The SMAI function block always calculates the residual quantities in case only the three phases (Ph-N) are connected ($GRPXM$ input not used).

The output signal $AI3P$ in the SMAI function block is a group output signal containing all processed electrical information from inputs $GRPXL1$, $GRPXL2$, $GRPXL3$ and $GRPXM$. Applications with a few exceptions shall always be connected to $AI3P$.

The input signal $REVROT$ is used to reverse the phase order.

A few points need to be ensured for SMAI to process the analog signal correctly.

- It is not mandatory to connect all the inputs of SMAI function. However, it is very important that same set of three phase analog signals should be connected to one SMAI function.
- The sequence of input connected to SMAI function inputs $GRPXL1$, $GRPXL2$, $GRPXL3$ and $GRPXM$ should normally represent phase L1, phase L2, phase L3 and neutral currents respectively.
- It is possible to connect analog signals available as *Ph-N* or *Ph-Ph* to SMAI. *ConnectionType* should be set according to the input connected.
- If the $GRPXM$ input is not connected and all three phase-to-earth inputs are connected, SMAI calculates the neutral input on its own and it is available at the $AI3P$ and AIN outputs. It is necessary that the *ConnectionType* should be set to *Ph-N*.
- If any two phase-to-earth inputs and neutral currents are connected, SMAI calculates the remaining third phase-to-neutral input on its own and it is available at the $AI3P$ output. It is necessary that the *ConnectionType* should be set to *Ph-N*.
- If any two phase-to-phase inputs are connected, SMAI calculates the remaining third phase-to-phase input on its own. It is necessary that the *ConnectionType* should be set to *Ph-Ph*.
- All three inputs $GRPXLx$ should be connected to SMAI for calculating sequence components for *ConnectionType* set to *Ph-N*.
- At least two inputs $GRPXLx$ should be connected to SMAI for calculating the positive and negative sequence component for *ConnectionType* set to *Ph-Ph*. Calculation of zero sequence requires $GRPXM$ input to be connected.
- Negation setting inverts (reverse) the polarity of the analog input signal. It is recommended that use of this setting is done with care, mistake in setting may lead to maloperation of directional functions.

Frequency adaptivity

SMAI function performs DFT calculations for obtaining various electrical parameters. DFT uses some reference frequency for performing calculations. For most of the cases, these calculations are done using a fixed DFT reference based on system frequency. However, if the frequency of the network is expected to vary more than 2 Hz from the nominal frequency, more accurate DFT results can be obtained if the adaptive DFT is used. This means that the frequency of the network is tracked and the DFT calculation is adapted according to that.

DFTRefExtOut and *DFTRefrence* need to be set appropriately for adaptive DFT calculations.

DFTRefExtOut: Setting valid only for the instance of function block SMAI_20_1. It decides the reference block for external output *SPFCOUT*.

DFTReference: Reference DFT for the block. This setting decides DFT reference for DFT calculations. *DFTReference* set to *InternalDFTRef* uses fixed DFT reference based on the set system frequency. *DFTReference* set to *DFTRefGrpX* uses DFT reference from the selected group block, when own group selected adaptive DFT reference will be used based on the calculated signal frequency from own group. *DFTReference* set to *External DFT Ref* will use reference based on input signal *DFTSPFC*.



Settings *DFTRefExtOut* and *DFTReference* shall be set to default value *InternalDFTRef* if no VT inputs are available. However, if it is necessary to use frequency adaptive DFT (*DFTReference* set to other than default, referring current measuring SMAI) when no voltages are available, note that the *MinValFreqMeas* setting is still set in reference to *UBase* (of the selected GBASVAL group). This means that the minimum level for the current amplitude is based on *UBase*. For example, if *UBase* is 20000, the resulting minimum amplitude for current is $20000 * 10\% = 2000$.

MinValFreqMeas: The minimum value of the voltage for which the frequency is calculated, expressed as percent of the voltage in the selected Global Base voltage group (GBASVAL:n, where $1 < n < 6$).

Below example shows a situation with adaptive frequency tracking with one reference selected for all instances. In practice each instance can be adapted to the needs of the actual application.

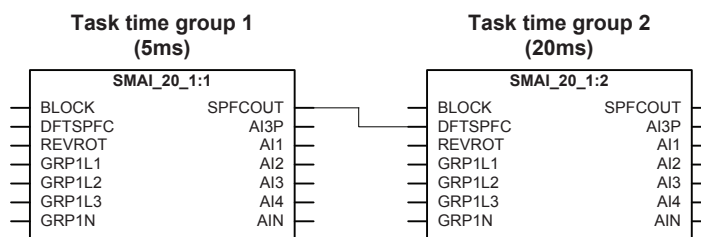

Task time group 1 (5ms)			Task time group 2 (20ms)	
SMAI instance	3 phase group		SMAI instance	3 phase group
SMAI_20_1:1	1		SMAI_20_1:2	1
SMAI_20_2:1	2		SMAI_20_2:2	2
SMAI_20_3:1	3		SMAI_20_3:2	3
SMAI_20_4:1	4		SMAI_20_4:2	4
SMAI_20_5:1	5		SMAI_20_5:2	5
SMAI_20_6:1	6		SMAI_20_6:2	6
SMAI_20_7:1	7	DFTRefGrp7	SMAI_20_7:2	7
SMAI_20_8:1	8		SMAI_20_8:2	8
SMAI_20_9:1	9		SMAI_20_9:2	9
SMAI_20_10:1	10		SMAI_20_10:2	10
SMAI_20_11:1	11		SMAI_20_11:2	11
SMAI_20_12:1	12		SMAI_20_12:2	12

IEC11000284-1-en.vsd

Figure 274: Configuration for using an instance in task time group 1 as DFT reference

Assume instance SMAI_20_7:1 in task time group 1 has been selected in the configuration to control the frequency tracking (For the SMAI_20_x task time groups). Note that the selected reference instance must be a voltage type.

For task time group 1 this gives the following settings:

For SMAI_20_1:1

DFTRefExtOut set to *DFTRefGrp7* so as to route SMAI_20_7:1 reference to the SPFCOUT output, *DFTRef* set to *DFTRefGrp7* so that SMAI_20_7:1 is used as reference.

For SMAI_20_2:1 to SMAI_20_12:1

DFTRef set to *DFTRefGrp7* so that SMAI_20_7:1 is used as reference.

For task time group 2 this gives the following settings:

For SMAI_20_1:2 to SMAI_20_12:2

DFTRef set to *External DFT ref* to use DFTSPFC input as reference.

15.10 Summation block 3 phase 3PHSUM

15.10.1 Identification

Function description	IEC 61850 identification	IEC 60617 identification	ANSI/IEEE C37.2 device number
Summation block 3 phase	3PHSUM	-	-

15.10.2 Functionality

Summation block 3 phase function 3PHSUM is used to get the sum of two sets of three-phase analog signals (of the same type) for those IED functions that might need it.

15.10.3 Function block

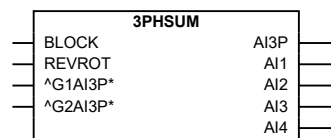

IEC09000201_1_en.vsd

Figure 275: 3PHSUM function block

15.10.4 Signals

Table 516: 3PHSUM Input signals

Name	Type	Default	Description
BLOCK	BOOLEAN	0	Block
REVROT	BOOLEAN	0	Reverse rotation
G1AI3P	GROUP SIGNAL	-	Group 1 three phase analog input from first SMAI
G2AI3P	GROUP SIGNAL	-	Group 2 three phase analog input from second SMAI

Table 517: 3PHSUM Output signals

Name	Type	Description
AI3P	GROUP SIGNAL	Linear combination of two connected three phase inputs
AI1	GROUP SIGNAL	Linear combination of input 1 signals from both SMAI blocks
AI2	GROUP SIGNAL	Linear combination of input 2 signals from both SMAI blocks
AI3	GROUP SIGNAL	Linear combination of input 3 signals from both SMAI blocks
AI4	GROUP SIGNAL	Linear combination of input 4 signals from both SMAI blocks

15.10.5 Settings

Table 518: 3PHSUM Non group settings (basic)

Name	Values (Range)	Unit	Step	Default	Description
GlobalBaseSel	1 - 6	-	1	1	Selection of one of the Global Base Value groups
SummationType	Group1+Group2 Group1-Group2 Group2-Group1 -(Group1+Group2)	-	-	Group1+Group2	Summation type
DFTReference	InternalDFTRef DFTRefGrp1 External DFT ref	-	-	InternalDFTRef	DFT reference

Table 519: 3PHSUM Non group settings (advanced)

Name	Values (Range)	Unit	Step	Default	Description
FreqMeasMinVal	5 - 200	%	1	10	Amplitude limit for frequency calculation in % of Ubase

15.10.6 Operation principle

Summation block 3 phase 3PHSUM receives the three-phase signals from Signal matrix for analog inputs function (SMAI). In the same way, the BLOCK input will reset all the outputs of the function to 0.

15.11 Global base values GBASVAL

15.11.1 Identification

Function description	IEC 61850 identification	IEC 60617 identification	ANSI/IEEE C37.2 device number
Global base values	GBASVAL	-	-

15.11.2 Functionality

Global base values function (GBASVAL) is used to provide global values, common for all applicable functions within the IED. One set of global values consists of values for current, voltage and apparent power and it is possible to have six different sets.

This is an advantage since all applicable functions in the IED use a single source of base values. This facilitates consistency throughout the IED and also facilitates a single point for updating values when necessary.

Each applicable function in the IED has a parameter, *GlobalBaseSel*, defining one out of the six sets of GBASVAL functions.

15.11.3 Settings

Table 520: GBASVAL Non group settings (basic)

Name	Values (Range)	Unit	Step	Default	Description
UBase	0.05 - 1000.00	kV	0.05	132.00	Global base voltage
IBase	1 - 50000	A	1	1000	Global base current
SBase	0.050 - 5000.000	MVA	0.001	229.000	Global base apparent power

15.12 Authority check ATHCHCK

15.12.1 Identification

Function description	IEC 61850 identification	IEC 60617 identification	ANSI/IEEE C37.2 device number
Authority check	ATHCHCK	-	-

15.12.2 Functionality

To safeguard the interests of our customers, both the IED and the tools that are accessing the IED are protected, by means of authorization handling. The authorization handling of the IED and the PCM600 is implemented at both access points to the IED:

- local, through the local HMI
- remote, through the communication ports

The IED users can be created, deleted and edited only with PCM600 IED user management tool.

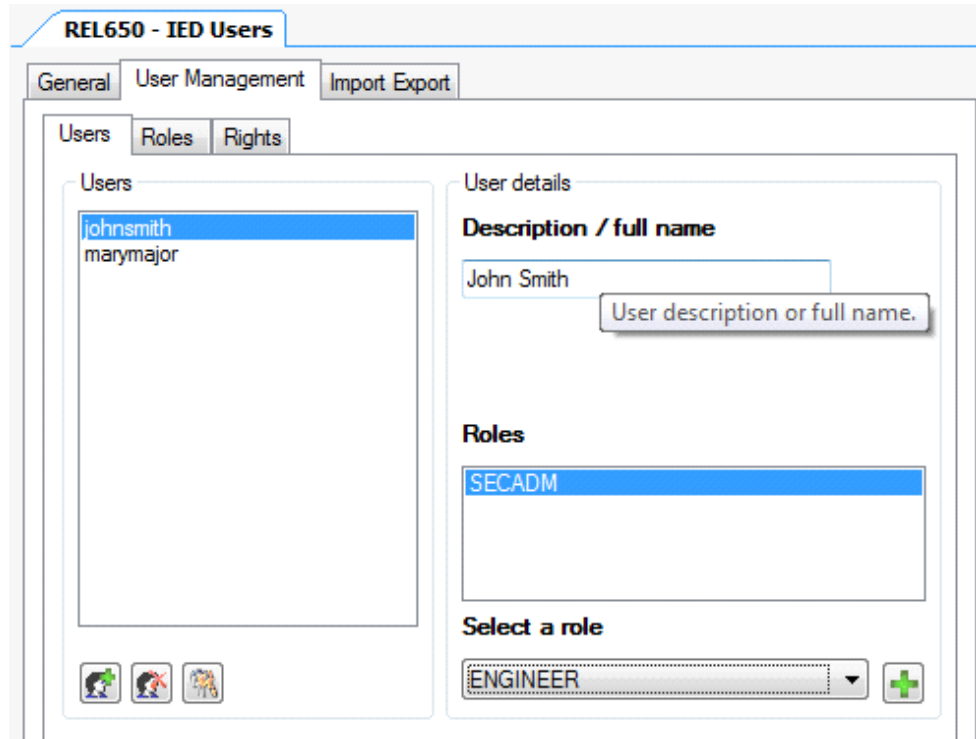

IEC12000202-1-en.vsd

Figure 276: PCM600 user management tool

15.12.3 Settings

The function does not have any parameters available in Local HMI or Protection and Control IED Manager (PCM600).

15.12.4 Operation principle

There are different levels (or types) of users that can access or operate different areas of the IED and tools functionality. The pre-defined user types are given in [Table 521](#).

Table 521: Pre-defined user types

User type	Access rights
SystemOperator	Control from local HMI, no bypass
ProtectionEngineer	All settings
DesignEngineer	Application configuration (including SMT, GDE and CMT)
UserAdministrator	User and password administration for the IED

The IED users can be created, deleted and edited only with the IED User Management within PCM600. The user can only LogOn or LogOff on the local HMI on the IED, there are no users, groups or functions that can be defined on local HMI.



Only characters A - Z, a - z and 0 - 9 should be used in user names and passwords.
The maximum of characters in a password is 12.



At least one user must be included in the UserAdministrator group to be able to write users, created in PCM600, to IED.

15.12.4.1 Authorization handling in the IED





At delivery the default user is the SuperUser. No Log on is required to operate the IED until a user has been created with the IED User Management..

Once a user is created and written to the IED, that user can perform a Log on, using the password assigned in the tool. Then the default user will be Guest.

If there is no user created, an attempt to log on will display a message box: "No user defined!"

If one user leaves the IED without logging off, then after the timeout (set in **Main menu/ Configuration/HMI/Screen/SCREEN:1**) elapses, the IED returns to Guest state, when only reading is possible. By factory default, the display timeout is set to 60 minutes.

If one or more users are created with the IED User Management and written to the IED, then, when a user attempts a Log on by pressing the  key or when the user attempts to perform an operation that is password protected, the Log on window opens.

The cursor is focused on the User identity field, so upon pressing the  key, one can change the user name, by browsing the list of users, with the "up" and "down" arrows. After choosing the right user name, the user must press the  key again. When it comes to password, upon pressing the  key, the following characters will show up: "*****". The user must scroll for every letter in the password. After all the letters are introduced (passwords are case sensitive) choose OK and press the  key again.

At successful Log on, the local HMI shows the new user name in the status bar at the bottom of the LCD. If the Log on is OK, when required to change for example a password protected setting, the local HMI returns to the actual setting folder. If the Log on has failed, an "Error Access Denied" message opens. If a user enters an incorrect password three times, that user will be blocked for ten minutes before a new attempt to log in can be performed. The user will be blocked from logging in, both from the local HMI and PCM600. However, other users are to log in during this period.

15.13 Authority management AUTHMAN

15.13.1 Identification

Function description	IEC 61850 identification	IEC 60617 identification	ANSI/IEEE C37.2 device number
Authority management	AUTHMAN	-	-

15.13.2 AUTHMAN

This function enables/disables the maintenance menu. It also controls the maintenance menu log on time out.

15.13.3 Settings

Table 522: AUTHMAN Non group settings (basic)

Name	Values (Range)	Unit	Step	Default	Description
MaintMenuEnable	No Yes	-	-	Yes	Maintenance menu enabled
AuthTimeout	10 Min 20 Min 30 Min 40 Min 50 Min 60 Min	-	-	10 Min	Authority blocking timeout

15.14 FTP access with password FTPACCS

15.14.1 Identification

Function description	IEC 61850 identification	IEC 60617 identification	ANSI/IEEE C37.2 device number
FTP access with SSL	FTPACCS	-	-

15.14.2 FTP access with SSL FTPACCS

The FTP Client defaults to the best possible security mode when trying to negotiate with SSL.

The automatic negotiation mode acts on port number and server features. It tries to immediately activate implicit SSL if the specified port is 990. If the specified port is any other, it tries to negotiate with explicit SSL via AUTH SSL/TLS.

Using FTP without SSL encryption gives the FTP client reduced capabilities. This mode is only for accessing disturbance recorder data from the IED.



If normal FTP is required to read out disturbance recordings, create a specific account for this purpose with rights only to do File transfer. The password of this user will be exposed in clear text on the wire.

15.14.3 Settings

Table 523: FTPACCS Non group settings (basic)

Name	Values (Range)	Unit	Step	Default	Description
PortSelection	None Front LAN1 Front+LAN1	-	-	Front+LAN1	Port selection for communication
SSLMode	FTP+FTPS FTPS	-	-	FTPS	Support for AUTH TLS/SSL
TCPPortFTP	1 - 65535	-	1	21	TCP port for FTP and FTP with Explicit SSL
TCPPortFTPS	1 - 65535	-	1	990	TCP port for FTP with Implicit SSL

15.15 Authority status ATHSTAT

15.15.1 Identification

Function description	IEC 61850 identification	IEC 60617 identification	ANSI/IEEE C37.2 device number
Authority status	ATHSTAT	-	-

15.15.2 Functionality

Authority status ATHSTAT function is an indication function block for user log-on activity. User denied attempt to log-on and user successful log-on are reported.

15.15.3 Function block

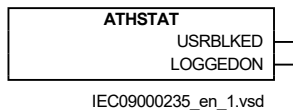

Figure 277: ATHSTAT function block

15.15.4 Signals

Table 524: ATHSTAT Output signals

Name	Type	Description
USRBLKED	BOOLEAN	At least one user is blocked by invalid password
LOGGEDON	BOOLEAN	At least one user is logged on

15.15.5 Settings

The function does not have any parameters available in Local HMI or Protection and Control IED Manager (PCM600)

15.15.6 Operation principle

Authority status (ATHSTAT) function informs about two events related to the IED and the user authorization:

- the fact that at least one user has tried to log on wrongly into the IED and it was blocked (the output USRBLKED)
- the fact that at least one user is logged on (the output LOGGEDON)

Whenever one of the two events occurs, the corresponding output (USRBLKED or LOGGEDON) is activated.

15.16 Denial of service

15.16.1 Functionality

The Denial of service functions (DOSLAN1 and DOSFRNT) are designed to limit overload on the IED produced by heavy Ethernet network traffic. The communication facilities must not be allowed to compromise the primary functionality of the device. All inbound network traffic will be quota controlled so that too heavy network loads can be controlled. Heavy network load might for instance be the result of malfunctioning equipment connected to the network.

15.16.2 Denial of service, frame rate control for front port DOSFRNT

15.16.2.1 Identification

Function description	IEC 61850 identification	IEC 60617 identification	ANSI/IEEE C37.2 device number
Denial of service, frame rate control for front port	DOSFRNT	-	-

15.16.2.2 Function block

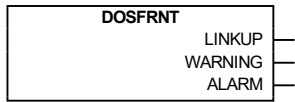

IEC09000133-1-en.vsd

Figure 278: DOSFRNT function block

15.16.2.3 Signals

Table 525: DOSFRNT Output signals

Name	Type	Description
LINKUP	BOOLEAN	Ethernet link status
WARNING	BOOLEAN	Frame rate is higher than normal state
ALARM	BOOLEAN	Frame rate is higher than throttle state

15.16.2.4 Settings

The function does not have any parameters available in the local HMI or PCM600.

15.16.2.5 Monitored data

Table 526: DOSFRNT Monitored data

Name	Type	Values (Range)	Unit	Description
State	INTEGER	0=Off 1=Normal 2=Throttle 3=DiscardLow 4=DiscardAll 5=StopPoll	-	Frame rate control state
Quota	INTEGER	-	%	Quota level in percent 0-100
IPPackRecNorm	INTEGER	-	-	Number of IP packets received in normal mode
IPPackRecPoll	INTEGER	-	-	Number of IP packets received in polled mode
IPPackDisc	INTEGER	-	-	Number of IP packets discarded
NonIPPackRecNorm	INTEGER	-	-	Number of non IP packets received in normal mode
NonIPPackRecPoll	INTEGER	-	-	Number of non IP packets received in polled mode
NonIPPackDisc	INTEGER	-	-	Number of non IP packets discarded

15.16.3 Denial of service, frame rate control for LAN1 port DOSLAN1

15.16.3.1 Identification

Function description	IEC 61850 identification	IEC 60617 identification	ANSI/IEEE C37.2 device number
Denial of service, frame rate control for LAN1 port	DOSLAN1	-	-

15.16.3.2 Function block

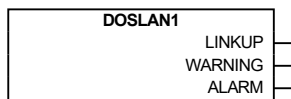

IEC09000134-1-en.vsd

Figure 279: DOSLAN1 function block

15.16.3.3 Signals

Table 527: DOSLAN1 Output signals

Name	Type	Description
LINKUP	BOOLEAN	Ethernet link status
WARNING	BOOLEAN	Frame rate is higher than normal state
ALARM	BOOLEAN	Frame rate is higher than throttle state

15.16.3.4 Settings

The function does not have any parameters available in the local HMI or PCM600.

15.16.3.5 Monitored data

Table 528: DOSLAN1 Monitored data

Name	Type	Values (Range)	Unit	Description
State	INTEGER	0=Off 1=Normal 2=Throttle 3=DiscardLow 4=DiscardAll 5=StopPoll	-	Frame rate control state
Quota	INTEGER	-	%	Quota level in percent 0-100
IPPackRecNorm	INTEGER	-	-	Number of IP packets received in normal mode
IPPackRecPoll	INTEGER	-	-	Number of IP packets received in polled mode
IPPackDisc	INTEGER	-	-	Number of IP packets discarded
Table continues on next page				

Name	Type	Values (Range)	Unit	Description
NonIPPackRecNorm	INTEGER	-	-	Number of non IP packets received in normal mode
NonIPPackRecPoll	INTEGER	-	-	Number of non IP packets received in polled mode
NonIPPackDisc	INTEGER	-	-	Number of non IP packets discarded

15.16.4 Operation principle

The Denial of service functions (DOSLAN1 and DOSFRNT) measures the IED load from communication and, if necessary, limit it for not jeopardizing the IEDs control and protection functionality due to high CPU load. The function has the following outputs:

- LINKUP indicates the Ethernet link status
- WARNING indicates that communication (frame rate) is higher than normal
- ALARM indicates that the IED limits communication

Section 16 IED physical connections

16.1 Protective earth connections

The IED shall be earthed with a 16.0 mm² flat copper cable.



The earth lead should be as short as possible, less than 1500 mm. Additional length is required for door mounting.

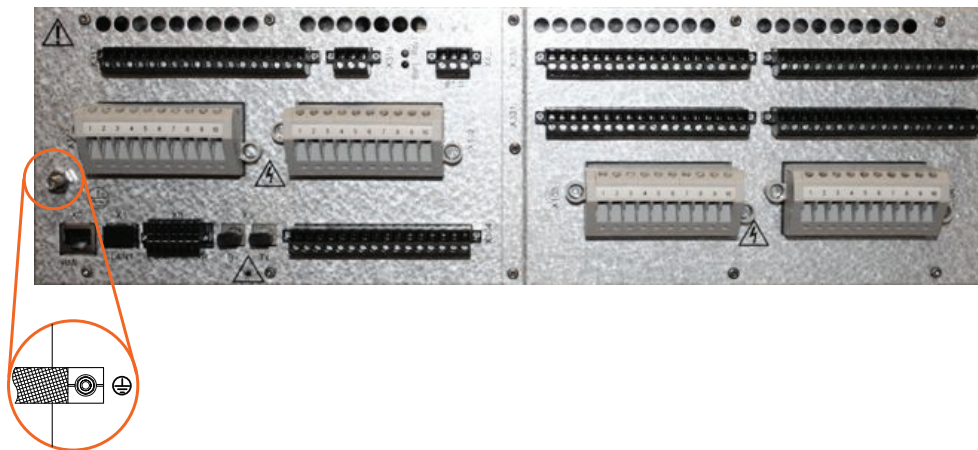

Figure 280: The protective earth pin is located to the left of connector X101 on the 3U full 19" case

16.2 Inputs

16.2.1 Measuring inputs

Each terminal for CTs/VTs is dimensioned for one 0.5...6.0 mm² wire or for two wires of maximum 2.5 mm².

Table 529: Analog input modules TRM

Terminal	TRM 6I + 4U	TRM 8I + 2U	TRM 4I + 1I + 5U	TRM 4I + 6U
X101-1, 2	1/5A	1/5A	1/5A	1/5A
X101-3, 4	1/5A	1/5A	1/5A	1/5A
X101-5, 6	1/5A	1/5A	1/5A	1/5A
X101-7, 8	1/5A	1/5A	1/5A	1/5A
X101-9, 10	1/5A	1/5A	0.1/0.5A	100/220V
X102-1, 2	1/5A	1/5A	100/220V	100/220V
X102-3, 4	100/220V	1/5A	100/220V	100/220V

Table continues on next page

Terminal	TRM 6I + 4U	TRM 8I + 2U	TRM 4I + 1I + 5U	TRM 4I + 6U
X102-5, 6	100/220V	1/5A	100/220V	100/220V
X102-7, 8	100/220V	100/220V	100/220V	100/220V
X102-9, 10	100/220V	100/220V	100/220V	100/220V

Table 530: Analog input modules AIM

Terminal	AIM 6I + 4U	AIM 4I + 1I + 5U
X103-1, 2	1/5A	1/5A
X103-3, 4	1/5A	1/5A
X103-5, 6	1/5A	1/5A
X103-7, 8	1/5A	1/5A
X103-9, 10	1/5A	0.1/0.5A
X104-1, 2	1/5A	100/220V
X104-3, 4	100/220V	100/220V
X104-5, 6	100/220V	100/220V
X104-7, 8	100/220V	100/220V
X104-9, 10	100/220V	100/220V



See the connection diagrams for information on the analog input module variant included in a particular configured IED. The primary and secondary rated values of the primary VT's and CT's are set for the analog inputs of the IED.

16.2.2 Auxiliary supply voltage input

The auxiliary voltage of the IED is connected to terminals X420-1 and X420-2/3. The terminals used depend on the power supply.

The permitted auxiliary voltage range of the IED is marked on top of the IED's LHMI.

Table 531: Auxiliary voltage supply of 110...250 V DC or 100...240 V AC

Case	Terminal	Description
3U full 19"	X420-1	- Input
	X420-3	+ Input

Table 532: Auxiliary voltage supply of 48-125 V DC

Case	Terminal	Description
3U full 19"	X420-1	- Input
	X420-2	+ Input

Table 533: Auxiliary voltage supply of 24-30 V DC

Case	Terminal	Description
3U full 19"	X420-3	- Input
	X420-2	+ Input

The two LEDs next to X420 indicate the following conditions:

- Bat1 = input voltage (for example, station battery) is within the expected range.
- Rdy1 = output voltage of internal power supply is within the expected range (no IED internal short circuit or overvoltage).

16.2.3 Binary inputs

The binary inputs can be used, for example, to generate a blocking signal, to unlatch output contacts, to trigger the disturbance recorder or for remote control of IED settings.

Each signal connector terminal is connected with one 0.5...2.5 mm² wire or with two 0.5...1.0 mm² wires.

Table 534: Binary inputs X304, 3U full 19"

Terminal	Description	PCM600 info	
		Hardware module instance	Hardware channel
X304-1	Common - for inputs 1-3		
X304-2	Binary input 1 +	COM_101	BI1
X304-3	Binary input 2 +	COM_101	BI2
X304-4	Binary input 3 +	COM_101	BI3
X304-5	Common - for inputs 4-6		
X304-6	Binary input 4 +	COM_101	BI4
X304-7	Binary input 5 +	COM_101	BI5
X304-8	Binary input 6 +	COM_101	BI6
X304-9	Common - for inputs 7-9		
X304-10	Binary input 7 +	COM_101	BI7
X304-11	Binary input 8 +	COM_101	BI8
X304-12	Binary input 9 +	COM_101	BI9
X304-13	Common - for inputs 10-12		
X304-14	Binary input 10 +	COM_101	BI10
X304-15	Binary input 11 +	COM_101	BI11
X304-16	Binary input 12 +	COM_101	BI12

Table 535:

Terminal	Description	PCM600 info	
		Hardware module instance	Hardware channel
X324-1	- for input 1	BIO_3	BI1
X324-2	Binary input 1 +	BIO_3	BI1
X324-3	-		
X324-4	Common - for inputs 2-3		
X324-5	Binary input 2 +	BIO_3	BI2
X324-6	Binary input 3 +	BIO_3	BI3
X324-7	-		
X324-8	Common - for inputs 4-5		
X324-9	Binary input 4 +	BIO_3	BI4
X324-10	Binary input 5 +	BIO_3	BI5
X324-11	-		
X324-12	Common - for inputs 6-7		
X324-13	Binary input 6 +	BIO_3	BI6
X324-14	Binary input 7 +	BIO_3	BI7
X324-15	-		
X324-16	Common - for inputs 8-9		
X324-17	Binary input 8 +	BIO_3	BI8
X324-18	Binary input 9 +	BIO_3	BI9

Table 536: Binary inputs X329, 3U full 19"

Terminal	Description	PCM600 info	
		Hardware module instance	Hardware channel
X329-1	- for input 1	BIO_4	BI1
X329-2	Binary input 1 +	BIO_4	BI1
X329-3	-		
X329-4	Common - for inputs 2-3		
X329-5	Binary input 2 +	BIO_4	BI2
X329-6	Binary input 3 +	BIO_4	BI3
X329-7	-		
X329-8	Common - for inputs 4-5		
X329-9	Binary input 4 +	BIO_4	BI4
X329-10	Binary input 5 +	BIO_4	BI5
X329-11	-		
X329-12	Common - for inputs 6-7		
X329-13	Binary input 6 +	BIO_4	BI6
X329-14	Binary input 7 +	BIO_4	BI7
X329-15	-		
Table continues on next page			

Terminal	Description	PCM600 info	
		Hardware module instance	Hardware channel
X329-16	Common - for inputs 8-9		
X329-17	Binary input 8 +	BIO_4	BI8
X329-18	Binary input 9 +	BIO_4	BI9

Table 537: Binary inputs X334, 3U full 19"

Terminal	Description	PCM600 info	
		Hardware module instance	Hardware channel
X334-1	- for input 1	BIO_5	BI1
X334-2	Binary input 1 +	BIO_5	BI1
X334-3	-		
X334-4	Common - for inputs 2-3		
X334-5	Binary input 2 +	BIO_5	BI2
X334-6	Binary input 3 +	BIO_5	BI3
X334-7	-		
X334-8	Common - for inputs 4-5		
X334-9	Binary input 4 +	BIO_5	BI4
X334-10	Binary input 5 +	BIO_5	BI5
X334-11	-		
X334-12	Common - for inputs 6-7		
X334-13	Binary input 6 +	BIO_5	BI6
X334-14	Binary input 7 +	BIO_5	BI7
X334-15	-		
X334-16	Common - for inputs 8-9		
X334-17	Binary input 8 +	BIO_5	BI8
X334-18	Binary input 9 +	BIO_5	BI9

Table 538: Binary inputs X339, 3U full 19"

Terminal	Description	PCM600 info	
		Hardware module instance	Hardware channel
X339-1	- for input 1	BIO_6	BI1
X339-2	Binary input 1 +	BIO_6	BI1
X339-3	-		
X339-4	Common - for inputs 2-3		
X339-5	Binary input 2 +	BIO_6	BI2
X339-6	Binary input 3 +	BIO_6	BI3
X339-7	-		
X339-8	Common - for inputs 4-5		
X339-9	Binary input 4 +	BIO_6	BI4

Table continues on next page

Terminal	Description	PCM600 info	
		Hardware module instance	Hardware channel
X339-10	Binary input 5 +	BIO_6	BI5
X339-11	-		
X339-12	Common - for inputs 6-7		
X339-13	Binary input 6 +	BIO_6	BI6
X339-14	Binary input 7 +	BIO_6	BI7
X339-15	-		
X339-16	Common - for inputs 8-9		
X339-17	Binary input 8 +	BIO_6	BI8
X339-18	Binary input 9 +	BIO_6	BI9

16.3 Outputs

16.3.1 Outputs for tripping, controlling and signalling

Output contacts PO1, PO2 and PO3 are power output contacts used, for example, for controlling circuit breakers.

Each signal connector terminal is connected with one 0.5...2.5 mm² wire or with two 0.5...1.0 mm² wires.



The connected DC voltage to outputs with trip circuit supervision (TCS) must have correct polarity or the trip circuit supervision TCSSCBR function will not operate properly.

Table 539: Output contacts X317, 3U full 19"

Terminal	Description	PCM600 info	
		Hardware module instance	Hardware channel
X317-1 X317-2	Power output 1, normally open (TCS) - +	PSM_102	BO1_PO_TCS
X317-3 X317-4	Power output 2, normally open (TCS) - +	PSM_102	BO2_PO_TCS
X317-5 X317-6	Power output 3, normally open (TCS) - +	PSM_102	BO3_PO_TCS
X317-7 X317-8	Power output 4, normally open	PSM_102	BO4_PO
X317-9 X317-10	Power output 5, normally open	PSM_102	BO5_PO
X317-11 X317-12	Power output 6, normally open	PSM_102	BO6_PO

Table 540: Output contacts X321, 3U full 19"

Terminal	Description	PCM600 info	
		Hardware module instance	Hardware channel
X321-1 X321-2	Power output 1, normally open	BIO_3	BO1_PO
X321-3 X321-4	Power output 2, normally open	BIO_3	BO2_PO
X321-5 X321-6	Power output 3, normally open	BIO_3	BO3_PO

Table 541: Output contacts X326, 3U full 19"

Terminal	Description	PCM600 info	
		Hardware module instance	Hardware channel
X326-1 X326-2	Power output 1, normally open	BIO_4	BO1_PO
X326-3 X326-4	Power output 2, normally open	BIO_4	BO2_PO
X326-5 X326-6	Power output 3, normally open	BIO_4	BO3_PO

Table 542: Output contacts X331, 3U full 19"

Terminal	Description	PCM600 info	
		Hardware module instance	Hardware channel
X331-1 X331-2	Power output 1, normally open	BIO_5	BO1_PO
X331-3 X331-4	Power output 2, normally open	BIO_5	BO2_PO
X331-5 X331-6	Power output 3, normally open	BIO_5	BO3_PO

Table 543: Output contacts X336, 3U full 19"

Terminal	Description	PCM600 info	
		Hardware module instance	Hardware channel
X336-1 X336-2	Power output 1, normally open	BIO_6	BO1_PO
X336-3 X336-4	Power output 2, normally open	BIO_6	BO2_PO
X336-5 X336-6	Power output 3, normally open	BIO_6	BO3_PO

16.3.2 Outputs for signalling

Signal output contacts are used for signalling on starting and tripping of the IED. On delivery from the factory, the start and alarm signals from all the protection stages are routed to signalling outputs. See connection diagrams.

Each signal connector terminal is connected with one 0.5...2.5 mm² wire or with two 0.5...1.0 mm² wires.

Table 544: Output contacts X317, 3U full 19"

Terminal	Description	PCM600 info	
		Hardware module instance	Hardware channel
X317-13 X317-14	Signal output 1, normally open	PSM_102	BO7_SO
X317-15 X317-16	Signal output 2, normally open	PSM_102	BO8_SO
X317-17 X317-18	Signal output 3, normally open	PSM_102	BO9_SO

Table 545: Output contacts X321, 3U full 19"

Terminal	Description	PCM600 info	
		Hardware module instance	Hardware channel
X321-7 X321-8	Signal output 1, normally open Signal output 1	BIO_3	BO4_SO
X321-9 X321-10	Signal output 2, normally open Signal output 2	BIO_3	BO5_SO
X321-11 X321-12	Signal output 3, normally open Signal output 3	BIO_3	BO6_SO
X321-13 X321-14 X321-15	Signal output 4, normally open Signal output 5, normally open Signal outputs 4 and 5, common	BIO_3 BIO_3	BO7_SO BO8_SO
X321-16 X321-17 X321-18	Signal output 6, normally closed Signal output 6, normally open Signal output 6, common	BIO_3	BO9_SO

Table 546: Output contacts X326, 3U full 19"

Terminal	Description	PCM600 info	
		Hardware module instance	Hardware channel
X326-7 X326-8	Signal output 1, normally open Signal output 1	BIO_4	BO4_SO
X326-9 X326-10	Signal output 2, normally open Signal output 2	BIO_4	BO5_SO
Table continues on next page			

Terminal	Description	PCM600 info	
		Hardware module instance	Hardware channel
X326-11	Signal output 3, normally open	BIO_4	BO6_SO
X326-12	Signal output 3		
X326-13	Signal output 4, normally open	BIO_4	BO7_SO
X326-14	Signal output 5, normally open	BIO_4	BO8_SO
X326-15	Signal outputs 4 and 5, common		
X326-16	Signal output 6, normally closed	BIO_4	BO9_SO
X326-17	Signal output 6, normally open		
X326-18	Signal output 6, common		

Table 547: Output contacts X331, 3U full 19"

Terminal	Description	PCM600 info	
		Hardware module instance	Hardware channel
X331-7	Signal output 1, normally open	BIO_5	BO4_SO
X331-8	Signal output 1		
X331-9	Signal output 2, normally open	BIO_5	BO5_SO
X331-10	Signal output 2		
X331-11	Signal output 3, normally open	BIO_5	BO6_SO
X331-12	Signal output 3		
X331-13	Signal output 4, normally open	BIO_5	BO7_SO
X331-14	Signal output 5, normally open		
X331-15	Signal outputs 4 and 5, common		
X331-16	Signal output 6, normally closed	BIO_5	BO9_SO
X331-17	Signal output 6, normally open		
X331-18	Signal output 6, common		

Table 548: Output contacts X336, 3U full 19"

Terminal	Description	PCM600 info	
		Hardware module instance	Hardware channel
X336-7	Signal output 1, normally open	BIO_6	BO4_SO
X336-8	Signal output 1		
X336-9	Signal output 2, normally open	BIO_6	BO5_SO
X336-10	Signal output 2		
X336-11	Signal output 3, normally open	BIO_6	BO6_SO
X336-12	Signal output 3		
X336-13	Signal output 4, normally open	BIO_6	BO7_SO
X336-14	Signal output 5, normally open		
X336-15	Signal outputs 4 and 5, common		
X336-16	Signal output 6, normally closed	BIO_6	BO9_SO
X336-17	Signal output 6, normally open		
X336-18	Signal output 6, common		

16.3.3 IRF

The IRF contact functions as a change-over output contact for the self-supervision system of the IED. Under normal operating conditions, the IED is energized and one of the two contacts is closed. When a fault is detected by the self-supervision system or the auxiliary voltage is disconnected, the closed contact drops off and the other contact closes.

Each signal connector terminal is connected with one 0.5...2.5 mm² wire or with two 0.5...1.0 mm² wires.

Table 549: IRF contact X319

Case	Terminal	Description
3U full 19"	X319-1	Closed; no IRF, and U _{aux} connected
	X319-2	Closed; IRF, or U _{aux} disconnected
	X319-3	IRF, common

16.4 Communication connections

The IED's LHMI is provided with an RJ-45 connector. The connector is intended for configuration and setting purposes.

Rear communication via the X1/LAN1 connector uses a communication module with the optical LC Ethernet connection.

The HMI connector X0 is used for connecting an external HMI to the IED. The X0/HMI connector must not be used for any other purpose.

Rear communication via the X8/EIA-485/IRIG-B connector uses a communication module with the galvanic EIA-485 serial connection.

16.4.1 Ethernet RJ-45 front connection

The IED's LHMI is provided with an RJ-45 connector designed for point-to-point use. The connector is intended for configuration and setting purposes. The interface on the PC has to be configured in a way that it obtains the IP address automatically if the DHCP Server is enabled in LHMI. There is a DHCP server inside IED for the front interface only.

The events and setting values and all input data such as memorized values and disturbance records can be read via the front communication port.

Only one of the possible clients can be used for parametrization at a time.

- PCM600
- LHMI

The default IP address of the IED through this port is 10.1.150.3.

The front port supports TCP/IP protocol. A standard Ethernet CAT 5 crossover cable is used with the front port.

16.4.2 Station communication rear connection

The default IP address of the IED through the Ethernet connection is 192.168.1.10. The physical connector is X1/LAN1. The interface speed is 100 Mbps for the 100BASE-FX LC alternative.

If the COM03 communication module is used, the X1/LAN1 A should be used. For redundant communication, X1/LAN A and X2/LAN B should be used. LAN2 A is not used in this product.

16.4.3 Optical serial rear connection

Serial communication can be used via optical connection in star topology. Connector type is glass (ST connector). Connection's idle state is indicated either with light on or light off. The physical connector is X9/Rx,Tx.

16.4.4 EIA-485 serial rear connection

The communication module follows the EIA-485 standard and is intended to be used in multi-point communication.

For the complete list of available connection diagrams, please refer to Section [Connection diagrams](#).

For four-wire connections, to terminate far end of the RS485 bus with the built-in 120 ohm resistors, connect X8:4 – 11 for Tx and X8:2 – 9 for Rx. This can be set via the local HMI under **Configuration/Communication/Station communication/RS485 port/RS485GEN:1/WireMode = Four-wire**.

For two-wire connections, to terminate far end of the RS485 bus with the built-in 120 ohm resistors, connect X8:4 - 11. This can be set via the local HMI under **Configuration/Communication/Station communication/RS485 port/RS485GEN:1/WireMode = Two-wire**.

Configure one of the node on the bus with BIAS (On) in order to set the bus signals on a defined level and non-floating which makes the bus more robust to disturbances. This can be set via the local HMI under **Configuration/Communication/Station communication/RS485 port/RS485GEN:1/BIAS = On/Off**.

To use the chassis grounds (grounding the cable shield, for example), the cable shield should be grounded on one end at X8:8 (direct ground) and at the other end at X8:1 (via capacitor).



Termination of the RS485 bus is always recommended regardless of the cable length.

16.4.5 Communication interfaces and protocols

Table 550: Supported station communication interfaces and protocols

Protocol	Ethernet		Serial	
	100BASE-FX LC	Glass fibre (ST connector)	EIA-485	
IEC 61850-8-1	•	-	-	
DNP3	•	•	•	
IEC 60870-5-103	-	•	•	
• = Supported				

16.4.6 Recommended industrial Ethernet switches

ABB recommends ABB industrial Ethernet switches.

16.5 Connection diagrams

The connection diagrams are delivered on the IED Connectivity package DVD as part of the product delivery.

The latest versions of the connection diagrams can be downloaded from <http://www.abb.com/substationautomation>.

Connection diagrams for Customized products

Connection diagram, 650 series 1.3 [1MRK006501-AD](#)

Connection diagrams for Configured products

Connection diagram, REC650 1.3, (3Ph/1CBA) A01 [1MRK006501-DD](#)

Connection diagram, REC650 1.3, (3Ph/1CBAB) A02 [1MRK006501-CD](#)

Connection diagram, REC650 1.3, (BCAB) A07 [1MRK006501-BD](#)

Section 17 Labels

17.1 Labels on IED

Front view of IED

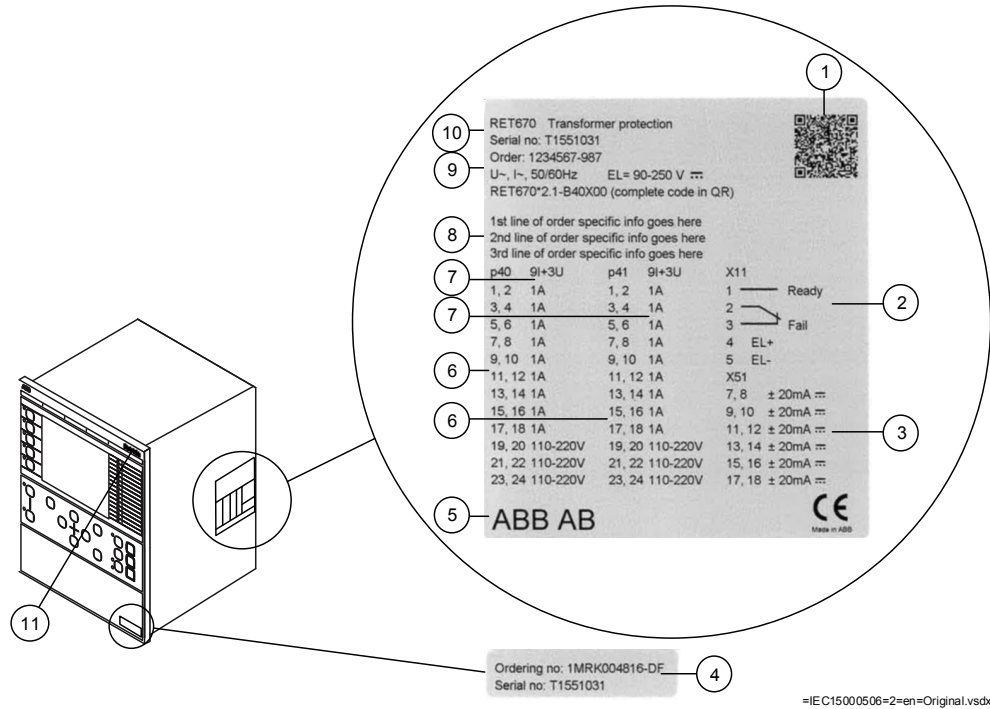
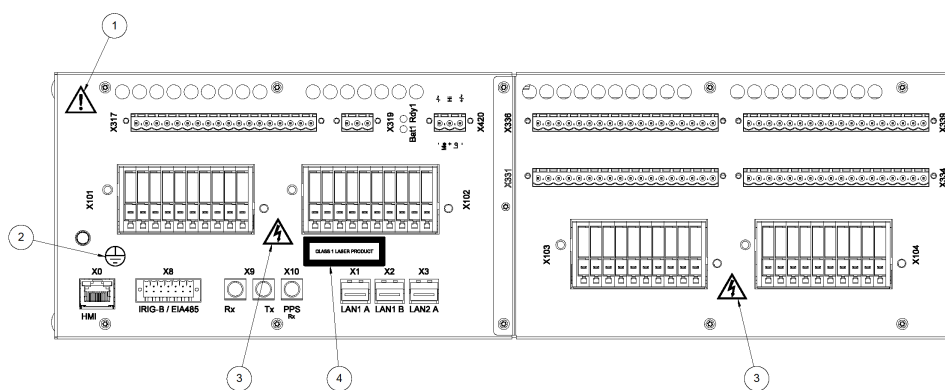

Figure 281: Example of IED label

- | | |
|----|---|
| 1 | QR-code containing the complete ordering code |
| 2 | Power supply module (PSM) |
| 3 | mA input module (MIM) |
| 4 | Ordering and serial number |
| 5 | Manufacturer |
| 6 | Transformer designations |
| 7 | Transformer input module, rated currents and voltages |
| 8 | Optional, customer specific information |
| 9 | Order number, dc supply voltage and rated frequency |
| 10 | Product type, description and serial number |
| 11 | Product type |

Rear view of IED



- 1 Caution label
- 2 Earthing
- 3 Warning label
- 4 Class 1 laser product label

It is used when an optical SFP or an MR/LR LDCM is configured in the product.

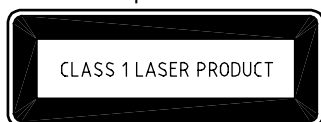

Section 18 Technical data

18.1 Dimensions

Table 551: Dimensions of the IED - 3U full 19" rack

Description	Value
Width	444 mm (17.48 inches)
Height	132 mm (5.20 inches), 3U
Depth	249.5 mm (9.82 inches)
Weight box	10 kg (<22.04 lbs)

18.2 Power supply

Table 552: Power supply

Description	PSM01	PSM02	PSM03
$U_{aux,nominal}$	24, 30V DC	48, 60, 110, 125 V DC	100, 110, 120, 220, 240 V AC, 50 and 60 Hz 110, 125, 220, 250 V DC
$U_{aux,variation}$	80...120% of U_n (19.2...36 V DC)	80...120% of U_n (38.4...150 V DC)	80...110% of U_n (80...264 V AC) 80...120% of U_n (88...300 V DC)
Maximum load of auxiliary voltage supply	35 W for DC 40 VA for AC		
Ripple in the DC auxiliary voltage	Max 15% of the DC value (at frequency of 100 and 120 Hz)		
Maximum interruption time in the auxiliary DC voltage without resetting the IED	50 ms at U_{aux}		
Resolution of the voltage measurement in PSM module	1 bit represents 0,5 V (+/- 1 VDC)	1 bit represents 1 V (+/- 1 VDC)	1 bit represents 2 V (+/- 1 VDC)

18.3 Energizing inputs

Table 553: TRM — Energizing quantities, rated values and limits for transformer inputs

Description	Value
Frequency	
Rated frequency f_r	50 or 60 Hz
Operating range	$f_r \pm 10\%$
Current inputs	
Table continues on next page	

Description	Value	
Rated current I_r	0.1 or 0.5 A ¹⁾	1 or 5 A ²⁾
Operating range	0 – 50 A	0 – 500 A
Thermal withstand	100 A for 1 s 20 A for 10 s 8 A for 1 min 4 A continuously	500 A for 1 s ^{*)} 100 A for 10 s 40 A for 1 min 20 A continuously
Dynamic withstand	250 A one half wave	1250 A one half wave
Burden	< 1 mVA at $I_r = 0.1$ A < 20 mVA at $I_r = 0.5$ A	< 10 mVA at $I_r = 1$ A < 200 mVA at $I_r = 5$ A
*) max. 350 A for 1 s when COMBITEST test switch is included.		
Voltage inputs**)		
Rated voltage U_r	100 or 220 V	
Operating range	0 – 420 V	
Thermal withstand	450 V for 10 s 420 V continuously	
Burden	< 50 mVA at 100 V < 200 mVA at 220 V	
**) all values for individual voltage inputs		
Note! All current and voltage data are specified as RMS values at rated frequency		

- 1) Residual current
2) Phase currents or residual current

18.4 Binary inputs

Table 554: Binary inputs

Description	Value
Operating range	Maximum input voltage 300 V DC
Rated voltage	24...250 V DC
Current drain	1.6...1.8 mA
Power consumption/input	<0.38 W
Threshold voltage	15...221 V DC (parametrizable in the range in steps of 1% of the rated voltage)

18.5 Signal outputs

Table 555: Signal output and IRF output

Description	Value
Rated voltage	250 V AC/DC
Continuous contact carry	5 A
Make and carry for 3.0 s	10 A
Make and carry 0.5 s	30 A
Breaking capacity when the control-circuit time constant L/R<40 ms, at U< 48/110/220 V DC	≤0.5 A/≤0.1 A/≤0.04 A

18.6 Power outputs

Table 556: Power output relays without TCS function

Description	Value
Rated voltage	250 V AC/DC
Continuous contact carry	8 A
Make and carry for 3.0 s	15 A
Make and carry for 0.5 s	30 A
Breaking capacity when the control-circuit time constant L/R<40 ms, at U< 48/110/220 V DC	≤1 A/≤0.3 A/≤0.1 A

Table 557: Power output relays with TCS function

Description	Value
Rated voltage	250 V DC
Continuous contact carry	8 A
Make and carry for 3.0 s	15 A
Make and carry for 0.5 s	30 A
Breaking capacity when the control-circuit time constant L/R<40 ms, at U< 48/110/220 V DC	≤1 A/≤0.3 A/≤0.1 A
Control voltage range	20...250 V DC
Current drain through the supervision circuit	~1.0 mA
Minimum voltage over the TCS contact	20 V DC

18.7 Data communication interfaces

Table 558: Ethernet interfaces

Ethernet interface	Protocol	Cable	Data transfer rate
100BASE-TX	-	CAT 6 S/FTP or better	100 MBits/s
100BASE-FX	TCP/IP protocol	Fibre-optic cable with LC connector	100 MBits/s

Table 559: Fibre-optic communication link

Wave length	Fibre type	Connector	Permitted path attenuation ¹⁾	Distance
1300 nm	MM 62.5/125 µm glass fibre core	LC	<8 dB	2 km

1) Maximum allowed attenuation caused by connectors and cable together

Table 560: X8/IRIG-B and EIA-485 interface

Type	Protocol	Cable
Tension clamp connection	IRIG-B	Shielded twisted pair cable Recommended: CAT 5, Belden RS-485 (9841- 9844) or Alpha Wire (Alpha 6222-6230)
Tension clamp connection	IEC 68070–5–103 DNP3.0	Shielded twisted pair cable Recommended: DESCAFLEX RD-H(ST)H-2x2x0.22mm ² , Belden 9729, Belden 9829

Table 561: IRIG-B

Type	Value	Accuracy
Input impedance	430 Ohm	-
Minimum input voltage HIGH	4.3 V	-
Maximum input voltage LOW	0.8 V	-

Table 562: EIA-485 interface

Type	Value	Conditions
Minimum differential driver output voltage	1.5 V	–
Maximum output current	60 mA	-
Minimum differential receiver input voltage	0.2 V	-
Supported bit rates	300, 600, 1200, 2400, 4800, 9600, 19200, 38400, 57600, 115200	-
Maximum number of 650 IEDs supported on the same bus	32	-
Max. cable length	925 m (3000 ft)	Cable: AWG24 or better, stub lines shall be avoided

Table 563: Serial rear interface

Type	Counter connector
Serial port (X9)	Optical serial port, type ST for IEC 60870-5-103 and DNP serial

Table 564: Optical serial port (X9)

Wave length	Fibre type	Connector	Permitted path attenuation ¹⁾
820 nm	MM 62,5/125 µm glass fibre core	ST	6.8 dB (approx. 1700m length with 4 db / km fibre attenuation)
820 nm	MM 50/125 µm glass fibre core	ST	2.4 dB (approx. 600m length with 4 db / km fibre attenuation)

1) Maximum allowed attenuation caused by fibre

18.8 Enclosure class

18.9 Ingress protection

Table 565: Ingress protection

Description	Value
IED front	IP 54
IED rear	IP 20
IED sides	IP 40
IED top	IP 40
IED bottom	IP 20

18.10 Environmental conditions and tests

Table 566: Environmental conditions

Description	Value
Operating temperature range	-25...+55°C (continuous)
Short-time service temperature range	-40...+70°C (<16h) Note: Degradation in MTBF and HMI performance outside the temperature range of -25...+55°C
Relative humidity	<93%, non-condensing
Atmospheric pressure	86...106 kPa
Altitude	up to 2000 m
Transport and storage temperature range	-40...+85°C

Table 567: Environmental tests

Description		Type test value	Reference
Cold tests	operation	96 h at -25°C 16 h at -40°C	IEC 60068-2-1/ANSI C37.90-2005 (chapter 4)
	storage	96 h at -40°C	
Dry heat tests	operation	16 h at +70°C	IEC 60068-2-2/ANSI C37.90-2005 (chapter 4)
	storage	96 h at +85°C	
Damp heat tests	steady state	240 h at +40°C humidity 93%	IEC 60068-2-78
	cyclic	6 cycles at +25 to +55°C humidity 93...95%	IEC 60068-2-30

Section 19 IED and functionality tests

19.1 Electromagnetic compatibility tests

Table 568: Electromagnetic compatibility tests

Description	Type test value	Reference
100 kHz and 1 MHz burst disturbance test		IEC 61000-4-18, level 3 IEC 60255-22-1 ANSI C37.90.1-2012
<ul style="list-style-type: none"> Common mode Differential mode 	2.5 kV 2.5 kV	
Electrostatic discharge test		IEC 61000-4-2, level 4 IEC 60255-22-2 ANSI C37.90.3-2001
<ul style="list-style-type: none"> Contact discharge Air discharge 	8 kV 15 kV	
Radio frequency interference tests		
<ul style="list-style-type: none"> Conducted, common mode Radiated, amplitude-modulated 	10 V (emf), f=150 kHz...80 MHz 20 V/m (rms), f=80...1000 MHz and f=1.4...2.7 GHz	IEC 61000-4-6, level 3 IEC 60255-22-6 IEC 61000-4-3, level 3 IEC 60255-22-3 ANSI C37.90.2-2004
Fast transient disturbance tests		IEC 61000-4-4 IEC 60255-22-4, class A ANSI C37.90.1-2012
<ul style="list-style-type: none"> Communication ports Other ports 	4 kV 4 kV	
Surge immunity test		IEC 61000-4-5 IEC 60255-22-5
<ul style="list-style-type: none"> Communication Other ports Power supply 	1 kV line-to-earth 2 kV line-to-earth, 1 kV line-to-line 4 kV line-to-earth, 2 kV line-to-line	
Power frequency (50 Hz) magnetic field		IEC 61000-4-8, level 5
<ul style="list-style-type: none"> 3 s Continuous 	1000 A/m 100 A/m	
Pulse magnetic field immunity test	1000A/m	IEC 61000-4-9, level 5
Damped oscillatory magnetic field	100A/m, 100 kHz and 1MHz	IEC 6100-4-10, level 5
Table continues on next page		

Description	Type test value	Reference
Power frequency immunity test <ul style="list-style-type: none"> Common mode Differential mode 	300 V rms 150 V rms	IEC 60255-22-7, class A IEC 61000-4-16
Voltage dips and short interruptions on DC power supply	Dips: 40%/200 ms 70%/500 ms Interruptions: 0-50 ms: No restart 0...∞ s : Correct behaviour at power down	IEC 60255-11 IEC 61000-4-11
Voltage dips and interruptions on AC power supply	Dips: 40% 10/12 cycles at 50/60 Hz 70% 25/30 cycles at 50/60 Hz Interruptions: 0-50 ms: No restart 0...∞ s: Correct behaviour at power down	IEC 60255-11 IEC 61000-4-11
Electromagnetic emission tests <ul style="list-style-type: none"> Conducted, RF-emission (mains terminal) 0.15...0.50 MHz 0.5...30 MHz <ul style="list-style-type: none"> Radiated RF-emission, IEC 30...230 MHz 230...1000 MHz	< 79 dB(μV) quasi peak < 66 dB(μV) average < 73 dB(μV) quasi peak < 60 dB(μV) average < 40 dB(μV/m) quasi peak, measured at 10 m distance < 47 dB(μV/m) quasi peak, measured at 10 m distance	EN 55011, class A IEC 60255-25 ANSI C63.4, FCC

19.2 Insulation tests

Table 569: Insulation tests

Description	Type test value	Reference
Dielectric tests: <ul style="list-style-type: none"> Test voltage 	2 kV, 50 Hz, 1 min 1 kV, 50 Hz, 1 min, communication	IEC 60255-5 ANSI C37.90-2005
Impulse voltage test: <ul style="list-style-type: none"> Test voltage 	5 kV, unipolar impulses, waveform 1.2/50 μs, source energy 0.5 J 1 kV, unipolar impulses, waveform 1.2/50 μs, source energy 0.5 J, communication	IEC 60255-5 ANSI C37.90-2005
Insulation resistance measurements		IEC 60255-5 ANSI C37.90-2005

Table continues on next page

Description	Type test value	Reference
<ul style="list-style-type: none"> Isolation resistance 	>100 M Ω , 500 V DC	
Protective bonding resistance <ul style="list-style-type: none"> Resistance 	<0.1 Ω (60 s)	IEC 60255-27

19.3 Mechanical tests

Table 570: Mechanical tests

Description	Reference	Requirement
Vibration response tests (sinusoidal)	IEC 60255-21-1	Class 1
Vibration endurance test	IEC60255-21-1	Class 1
Shock response test	IEC 60255-21-2	Class 1
Shock withstand test	IEC 60255-21-2	Class 1
Bump test	IEC 60255-21-2	Class 1
Seismic test	IEC 60255-21-3	Class 2

19.4 Product safety

Table 571: Product safety

Description	Reference
LV directive	2006/95/EC
Standard	EN 60255-27 (2005)

19.5 EMC compliance

Table 572: EMC compliance

Description	Reference
EMC directive	2004/108/EC
Standard	EN 50263 (2000) EN 60255-26 (2007)

Section 20 Time inverse characteristics

20.1 Application

In order to assure time selectivity between different overcurrent protections in different points in the network different time delays for the different relays are normally used. The simplest way to do this is to use definite time delay. In more sophisticated applications current dependent time characteristics are used. Both alternatives are shown in a simple application with three overcurrent protections connected in series.

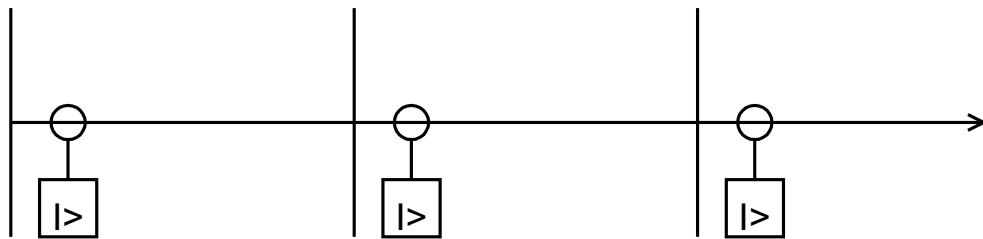

xx05000129.vsd

Figure 282: Three overcurrent protections connected in series

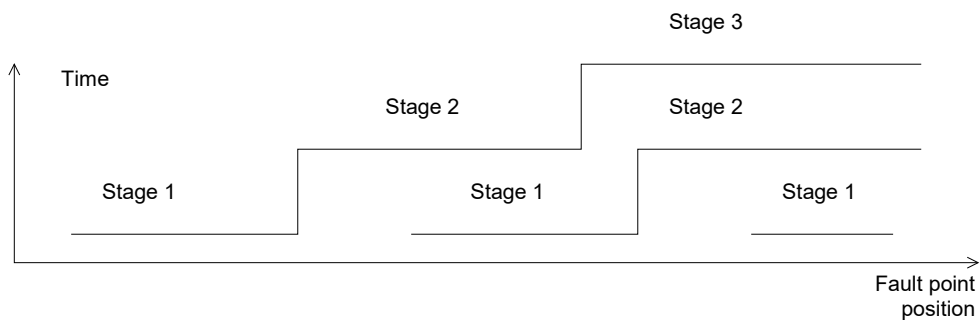

en05000130.vsd

Figure 283: Definite time overcurrent characteristics

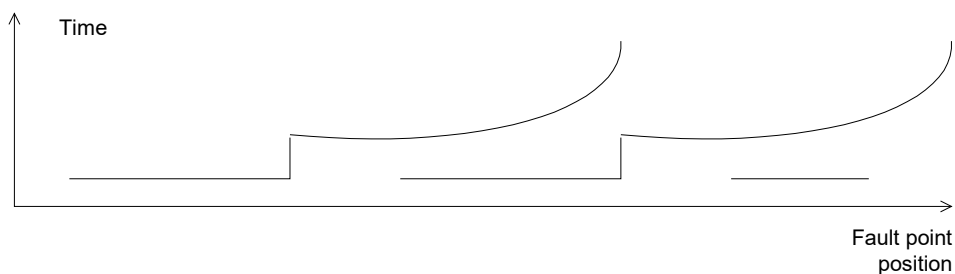

en05000131.vsd

Figure 284: Inverse time overcurrent characteristics with inst. function

The inverse time characteristic makes it possible to minimize the fault clearance time and still assure the selectivity between protections.

To assure selectivity between protections there must be a time margin between the operation time of the protections. This required time margin is dependent of following factors, in a simple case with two protections in series:

- Difference between pick-up time of the protections to be co-ordinated
- Opening time of the breaker closest to the studied fault
- Reset time of the protection
- Margin dependent of the time-delay inaccuracy of the protections

Assume we have the following network case.

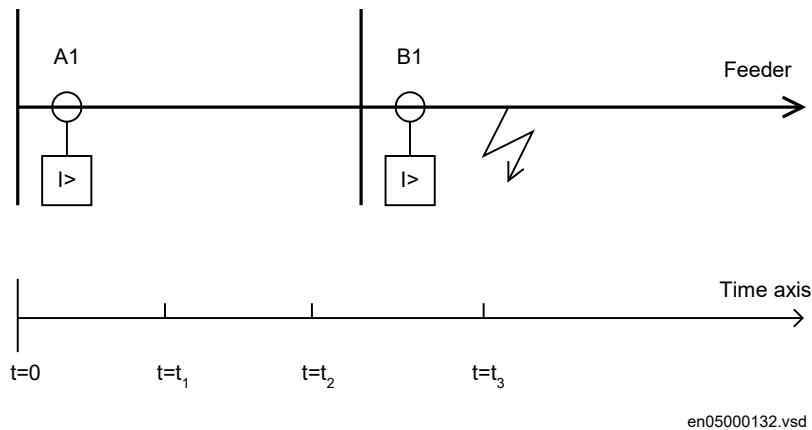

Figure 285: Selectivity steps for a fault on feeder B1

where:

- $t=0$ is The fault occurs
- $t=t_1$ is Protection B1 trips
- $t=t_2$ is Breaker at B1 opens
- $t=t_3$ is Protection A1 resets

In the case protection B1 shall operate without any intentional delay (instantaneous). When the fault occurs the protections start to detect the fault current. After the time t_1 the protection B1 send a trip signal to the circuit breaker. The protection A1 starts its delay timer at the same time, with some deviation in time due to differences between the two protections. There is a possibility that A1 will start before the trip is sent to the B1 circuit breaker.

At the time t_2 the circuit breaker B1 has opened its primary contacts and thus the fault current is interrupted. The breaker time ($t_2 - t_1$) can differ between different faults. The maximum opening time can be given from manuals and test protocols. Still at t_2 the timer of protection A1 is active.

At time t_3 the protection A1 is reset, i.e. the timer is stopped.

In most applications it is required that the delay times shall reset as fast as possible when the current fed to the protection drops below the set current level, the reset time shall be minimized. In some applications it is however beneficial to have some type of delayed reset time of the overcurrent function. This can be the case in the following applications:

- If there is a risk of intermittent faults. If the current relay, close to the faults, starts and resets there is a risk of unselective trip from other protections in the system.
- Delayed resetting could give accelerated fault clearance in case of automatic reclosing to a permanent fault.
- Overcurrent protection functions are sometimes used as release criterion for other protection functions. It can often be valuable to have a reset delay to assure the release function.

20.2 Operation principle

20.2.1 Mode of operation

The function can operate in a definite time-lag mode or in a current definite inverse time mode. For the inverse time characteristic both ANSI and IEC based standard curves are available.

If current in any phase exceeds the set start current value, a timer, according to the selected operating mode, is started. The component always uses the maximum of the three phase current values as the current level used in timing calculations.

In case of definite time-lag mode the timer will run constantly until the time is reached or until the current drops below the reset value (start value minus the hysteresis) and the reset time has elapsed.

The general expression for inverse time curves is according to equation 75.

$$t[s] = \left(\frac{A}{\left(\frac{i}{in >} \right)^p - C} + B \right) \cdot k$$

(Equation 75)

where:

p, A, B, C

in >

k

i

are constants defined for each curve type,

is the set start current for step n,

is set time multiplier for step n and

is the measured current.

For inverse time characteristics a time will be initiated when the current reaches the set start level. From the general expression of the characteristic the following can be seen:

$$(t_{op} - B \cdot k) \cdot \left(\left(\frac{i}{in >} \right)^p - C \right) = A \cdot k$$

(Equation 76)

where:

t_{op} is the operating time of the protection

The time elapsed to the moment of trip is reached when the integral fulfils according to equation 77, in addition to the constant time delay:

$$\int_0^i \left(\left(\frac{i}{in >} \right)^p - C \right) \cdot dt \geq A \cdot k$$

(Equation 77)

For the numerical protection the sum below must fulfil the equation for trip.

$$\Delta t \cdot \sum_{j=1}^n \left(\left(\frac{i(j)}{in >} \right)^p - C \right) \geq A \cdot k$$

(Equation 78)

where:

$j = 1$

is the first protection execution cycle when a fault has been detected, that is, when

$$\frac{i}{in >} > 1$$

Δt

is the time interval between two consecutive executions of the protection algorithm,

n

is the number of the execution of the algorithm when the trip time equation is fulfilled, that is, when a trip is given and

$i(j)$

is the fault current at time j

For inverse time operation, the inverse time characteristic is selectable. Both the IEC and ANSI/IEEE standardized inverse time characteristics are supported.

For the IEC curves there is also a setting of the minimum time-lag of operation, see figure 286.

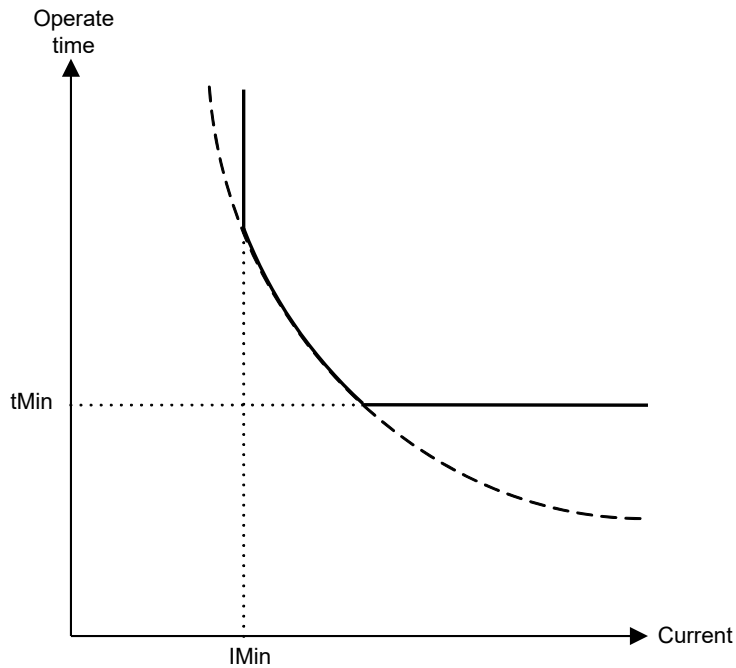

IEC05000133-3-en.vsd

Figure 286: Minimum time-lag operation for the IEC curves

In order to fully comply with IEC curves definition setting parameter tMin shall be set to the value which is equal to the operating time of the selected IEC inverse time curve for measured current of twenty times the set current start value. Note that the operating time value is dependent on the selected setting value for time multiplier k.

In addition to the ANSI and IEC standardized characteristics, there are also two additional inverse curves available; the RI curve and the RD curve.

The RI inverse time curve emulates the characteristic of the electromechanical ASEA relay RI. The curve is described by equation 80:

$$t[s] = \left(\frac{k}{0.339 - 0.235 \cdot \frac{in >}{i}} \right)$$

(Equation 80)

where:

- in> is the set start current for step n
- k is set time multiplier for step n
- i is the measured current

The RD inverse curve gives a logarithmic delay, as used in the Combiflex protection RXIDG. The curve enables a high degree of selectivity required for sensitive residual earth-fault current protection, with ability to detect high-resistive earth faults. The curve is described by equation 81:

$$t[s] = 5.8 - 1.35 \cdot \ln\left(\frac{i}{k \cdot i_{n>}}\right)$$

(Equation 81)

where:

- $i_{n>}$ is the set start current for step n,
- k is set time multiplier for step n and
- i is the measured current

The timer will be reset directly when the current drops below the set start current level minus the hysteresis.

20.3 Inverse time characteristics



When inverse time overcurrent characteristic is selected, the operate time of the stage will be the sum of the inverse time delay and the set definite time delay. Thus, if only the inverse time delay is required, it is of utmost importance to set the definite time delay for that stage to zero.

Table 573: ANSI Inverse time characteristics

Function	Range or value	Accuracy
Operating characteristic: $t = \left(\frac{A}{(I^P - 1)} + B \right) \cdot k + t_{Def}$ $I = I_{measured} / I_{set}$	k = (0.05-999) in steps of 0.01	-
ANSI Extremely Inverse	A=28.2, B=0.1217, P=2.0	
ANSI Very inverse	A=19.61, B=0.491, P=2.0	
ANSI Normal Inverse	A=0.0086, B=0.0185, P=0.02, tr=0.46	
ANSI Moderately Inverse	A=0.0515, B=0.1140, P=0.02	
ANSI Long Time Extremely Inverse	A=64.07, B=0.250, P=2.0	
ANSI Long Time Very Inverse	A=28.55, B=0.712, P=2.0	
ANSI Long Time Inverse	A=0.086, B=0.185, P=0.02	

Table 574: IEC Inverse time characteristics

Function	Range or value	Accuracy
Operating characteristic: $t = \left(\frac{A}{(I^P - 1)} \right) \cdot k$ $I = I_{\text{measured}}/I_{\text{set}}$	k = (0.05-999) in steps of 0.01	-
IEC Normal Inverse	A=0.14, P=0.02	
IEC Very inverse	A=13.5, P=1.0	
IEC Inverse	A=0.14, P=0.02	
IEC Extremely inverse	A=80.0, P=2.0	
IEC Short time inverse	A=0.05, P=0.04	
IEC Long time inverse	A=120, P=1.0	



The parameter setting *Characterist1 and 4/Reserved* shall not be used, since this parameter setting is for future use and not implemented yet.

Table 575: RI and RD type inverse time characteristics

Function	Range or value	Accuracy
RI type inverse characteristic $t = \frac{1}{0.339 - \frac{0.236}{I}} \cdot k$ $I = I_{\text{measured}}/I_{\text{set}}$	k = (0.05-999) in steps of 0.01	
RD type logarithmic inverse characteristic $t = 5.8 - \left(1.35 \cdot \ln \frac{I}{k} \right)$ $I = I_{\text{measured}}/I_{\text{set}}$	k = (0.05-999) in steps of 0.01	

Table 576: Inverse time characteristics for overvoltage protection

Function	Range or value	Accuracy
Type A curve: $t = \frac{k}{\left(\frac{U - U >}{U >}\right)}$ $U > = U_{\text{set}}$ $U = U_{\text{measured}}$	k = (0.05-1.10) in steps of 0.01	±5% +60 ms
Type B curve: $t = \frac{k \cdot 480}{\left(32 \cdot \frac{U - U >}{U >} - 0.5\right)^{2.0} - 0.035}$	k = (0.05-1.10) in steps of 0.01	
Type C curve: $t = \frac{k \cdot 480}{\left(32 \cdot \frac{U - U >}{U >} - 0.5\right)^{3.0} - 0.035}$	k = (0.05-1.10) in steps of 0.01	

Table 577: Inverse time characteristics for undervoltage protection

Function	Range or value	Accuracy
Type A curve: $t = \frac{k}{\left(\frac{U < -U}{U <}\right)}$ $U < = U_{\text{set}}$ $U = U_{\text{measured}}$	k = (0.05-1.10) in steps of 0.01	±5% +60 ms
Type B curve: $t = \frac{k \cdot 480}{\left(32 \cdot \frac{U < -U}{U <} - 0.5\right)^{2.0}} + 0.055$ $U < = U_{\text{set}}$ $U = U_{\text{measured}}$	k = (0.05-1.10) in steps of 0.01	

Table 578: Inverse time characteristics for residual overvoltage protection

Function	Range or value	Accuracy
Type A curve: $t = \frac{k}{\left(\frac{U - U_{>}}{U_{>}}\right)}$ $U_{>} = U_{\text{set}}$ $U = U_{\text{measured}}$	k = (0.05-1.10) in steps of 0.01	±5% +70 ms
Type B curve: $t = \frac{k \cdot 480}{\left(32 \cdot \frac{U - U_{>}}{U_{>}} - 0.5\right)^{2.0} - 0.035}$	k = (0.05-1.10) in steps of 0.01	
Type C curve: $t = \frac{k \cdot 480}{\left(32 \cdot \frac{U - U_{>}}{U_{>}} - 0.5\right)^{3.0} - 0.035}$	k = (0.05-1.10) in steps of 0.01	

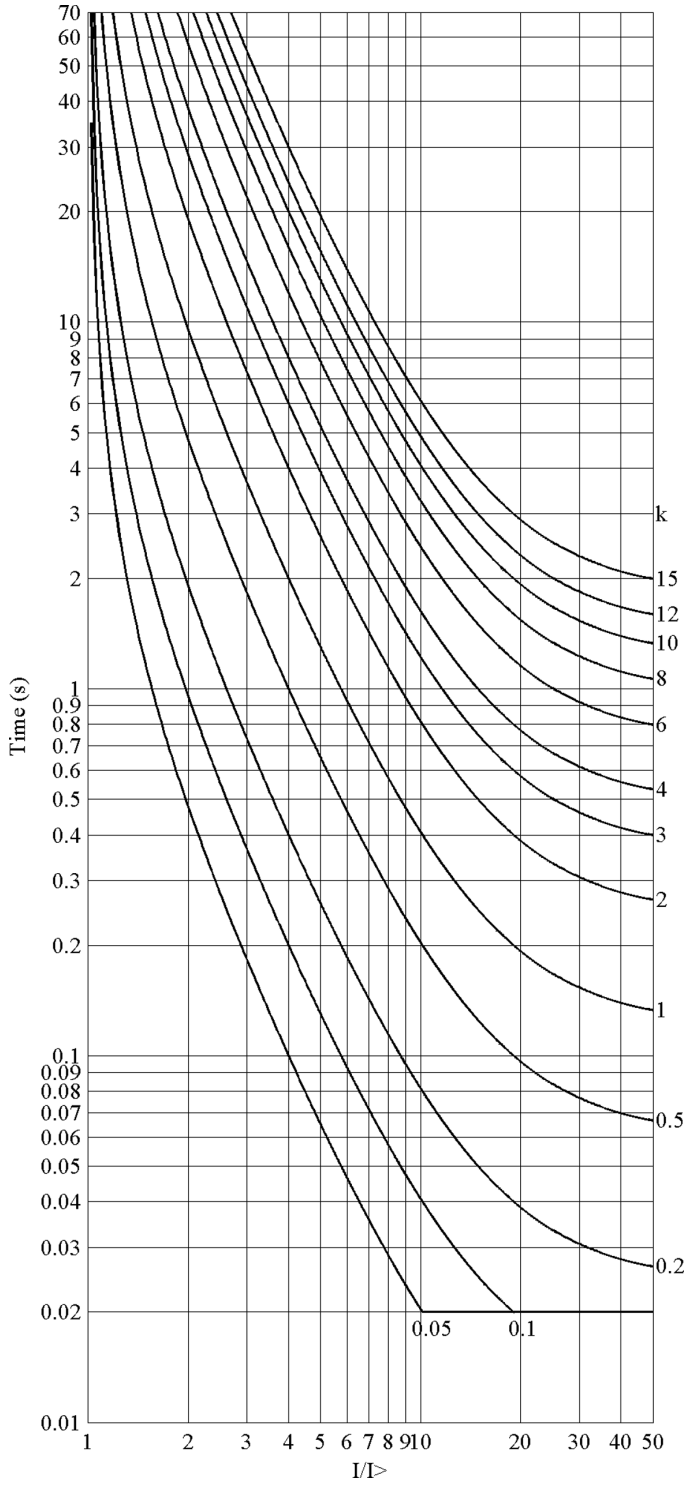

Figure 287: ANSI Extremely inverse time characteristics

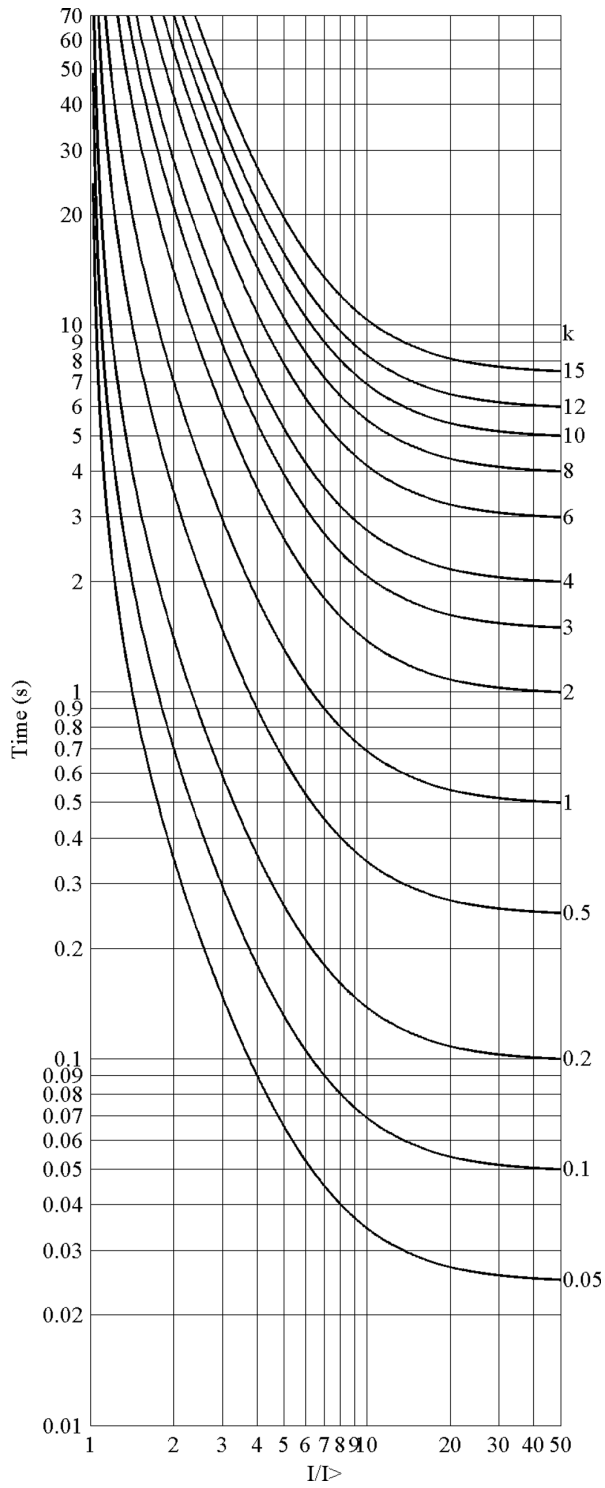

Figure 288: ANSI Very inverse time characteristics

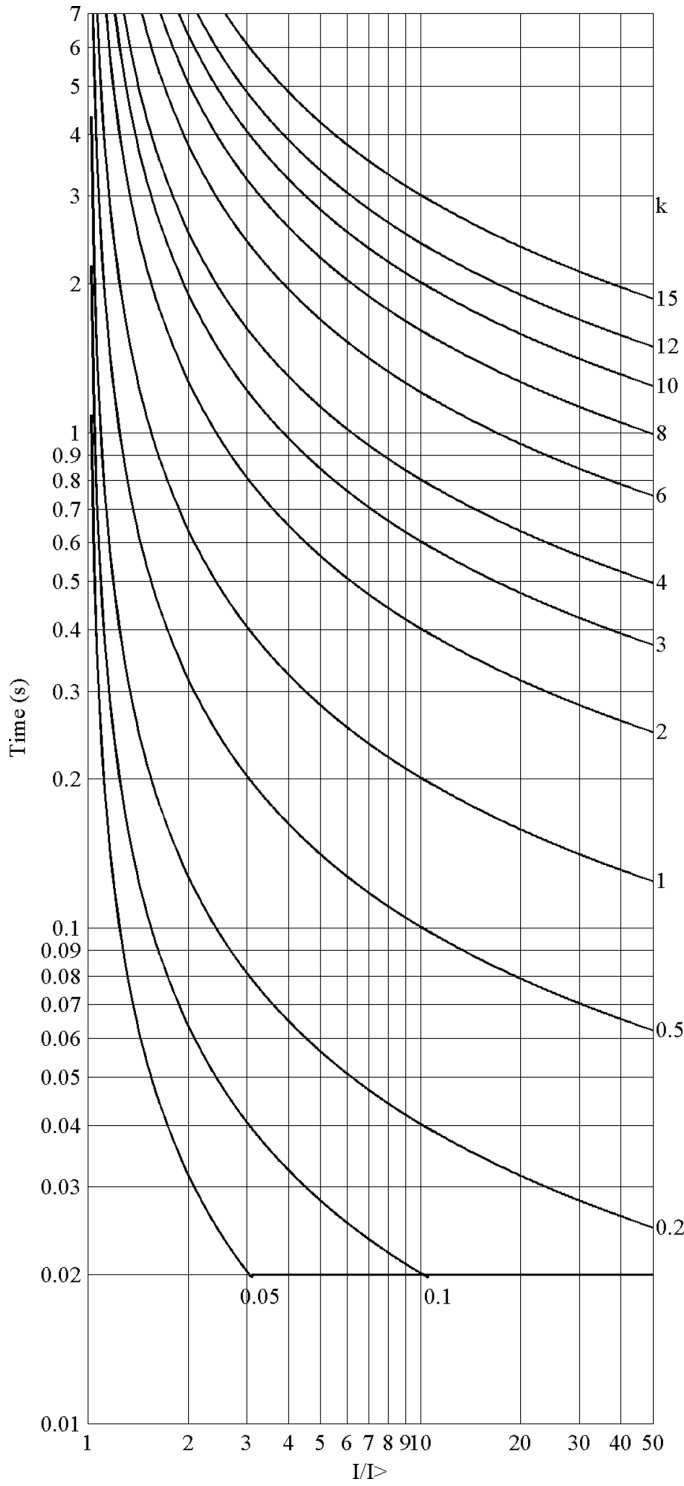

Figure 289: ANSI Normal inverse time characteristics

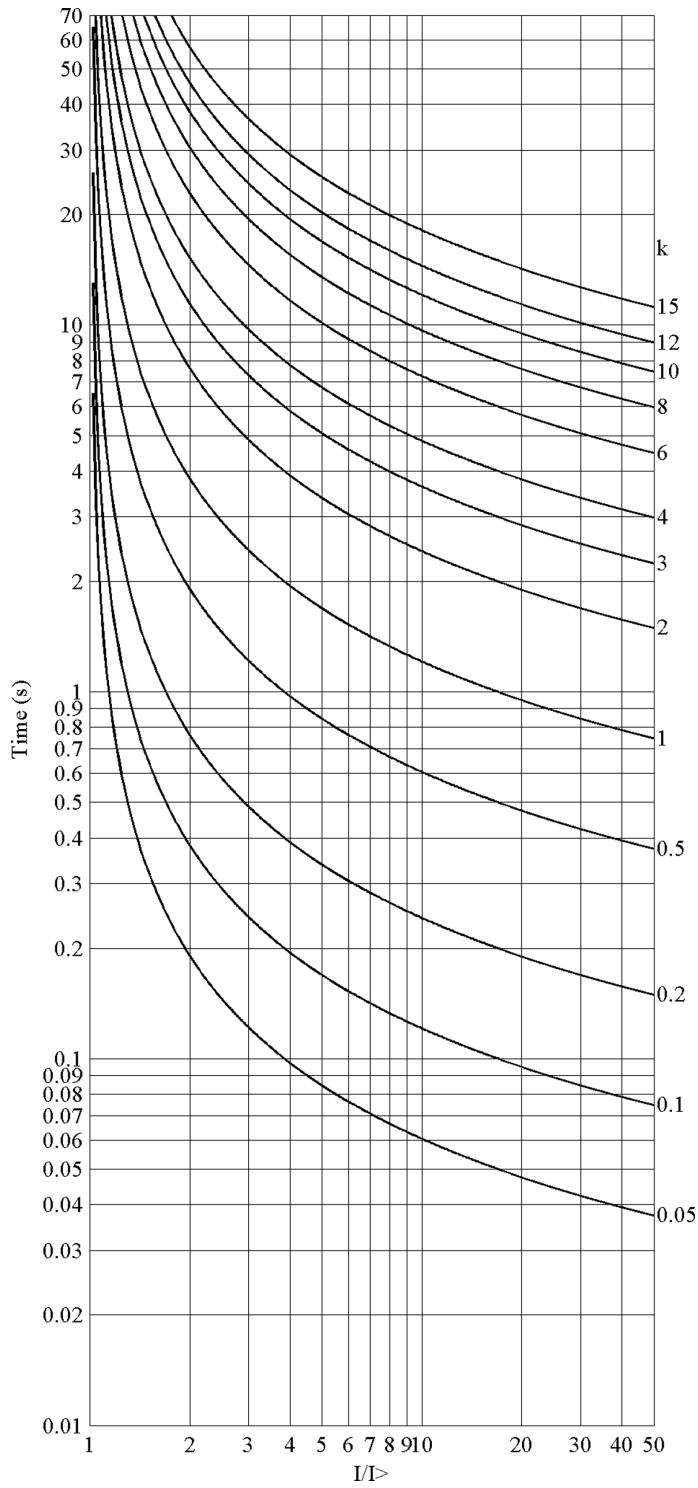

Figure 290: ANSI Moderately inverse time characteristics

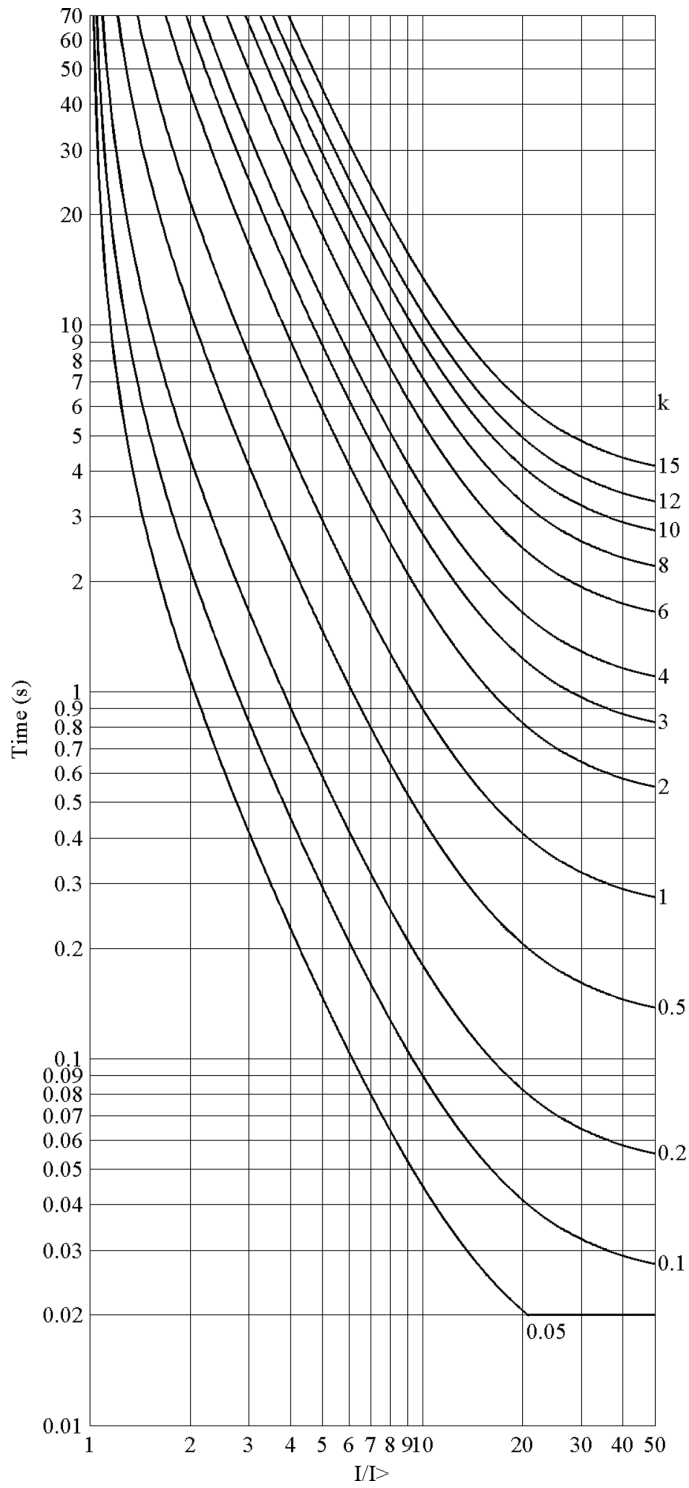

Figure 291: ANSI Long time extremely inverse time characteristics

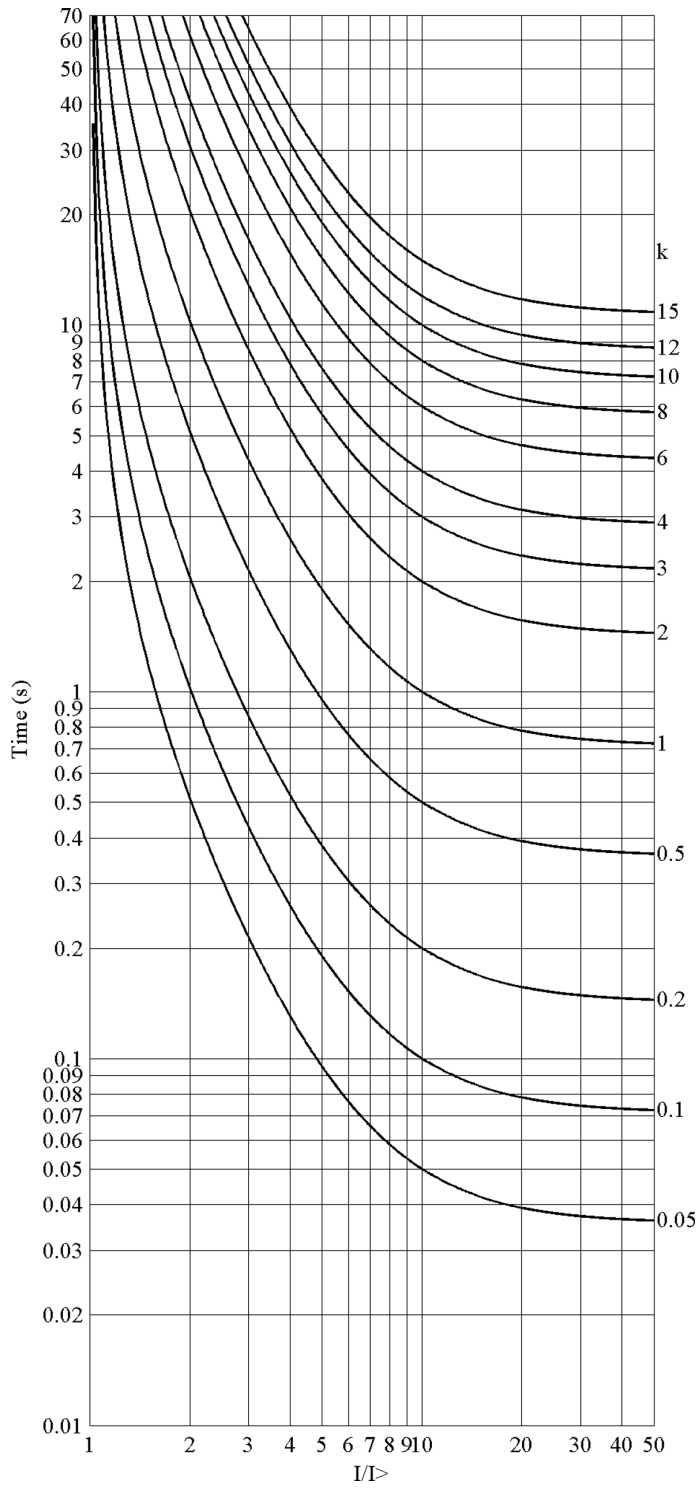

Figure 292: ANSI Long time very inverse time characteristics

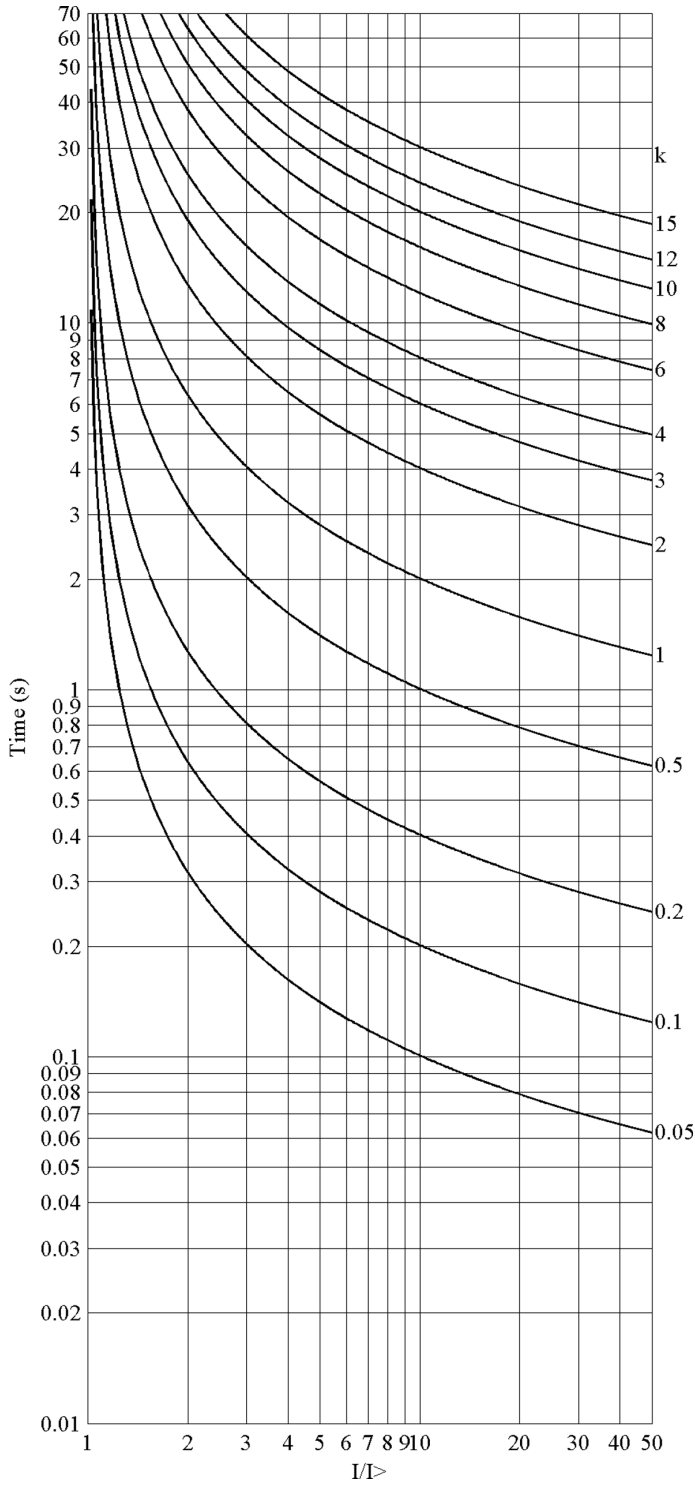

Figure 293: ANSI Long time inverse time characteristics

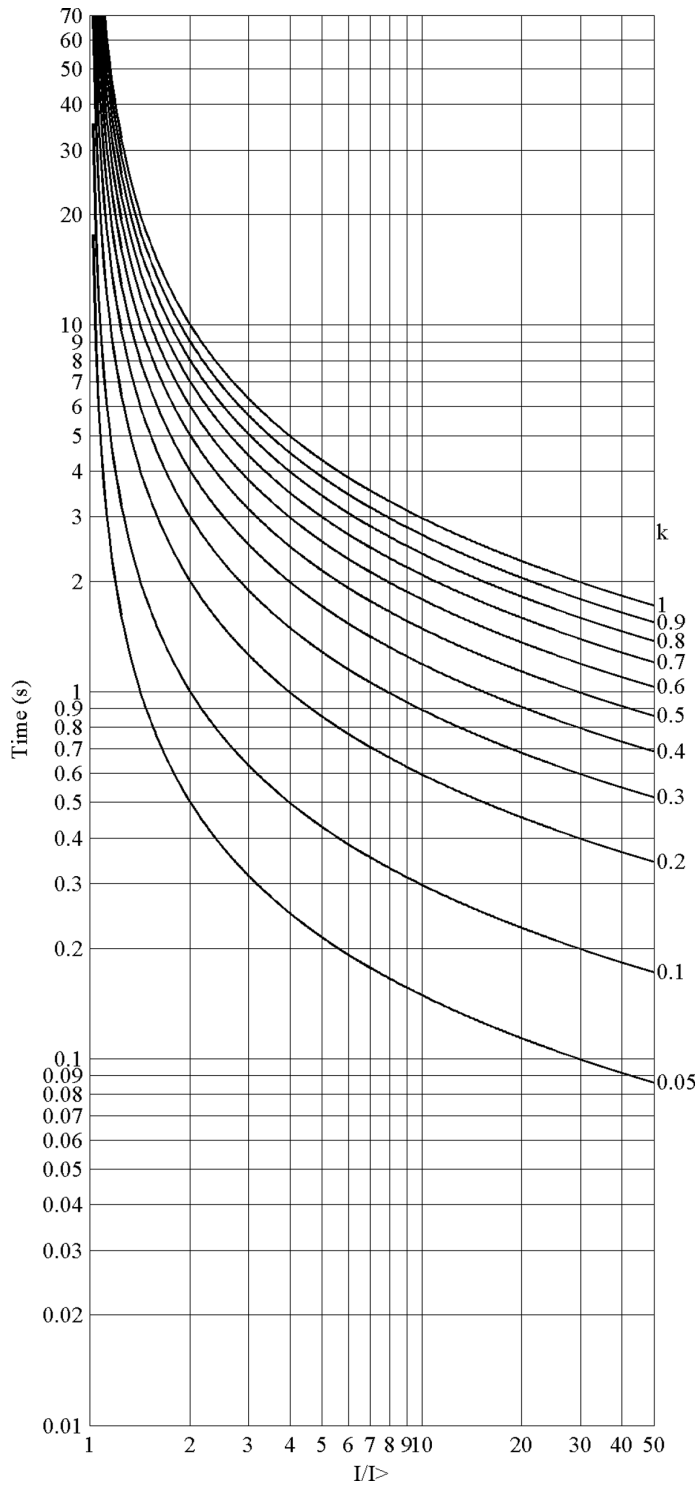

Figure 294: IEC Normal inverse time characteristics

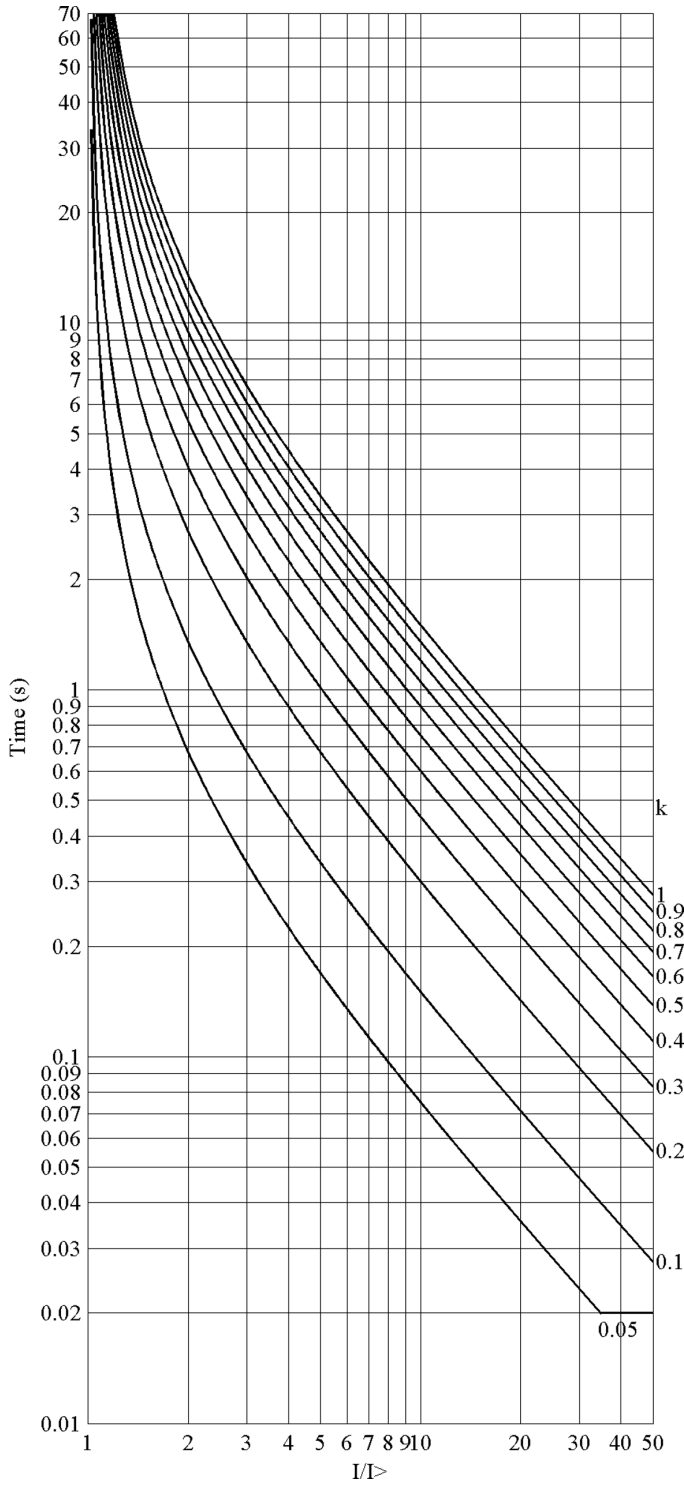

Figure 295: IEC Very inverse time characteristics

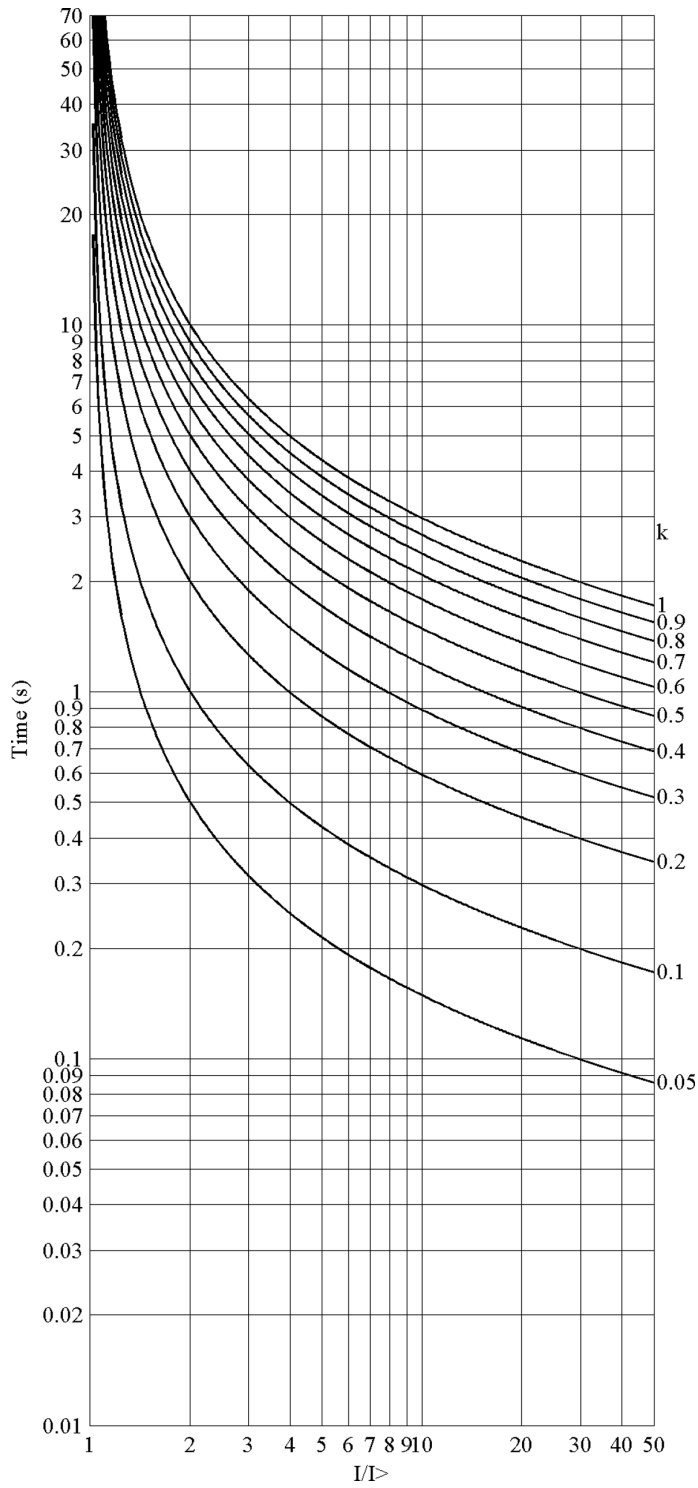

Figure 296: IEC Inverse time characteristics

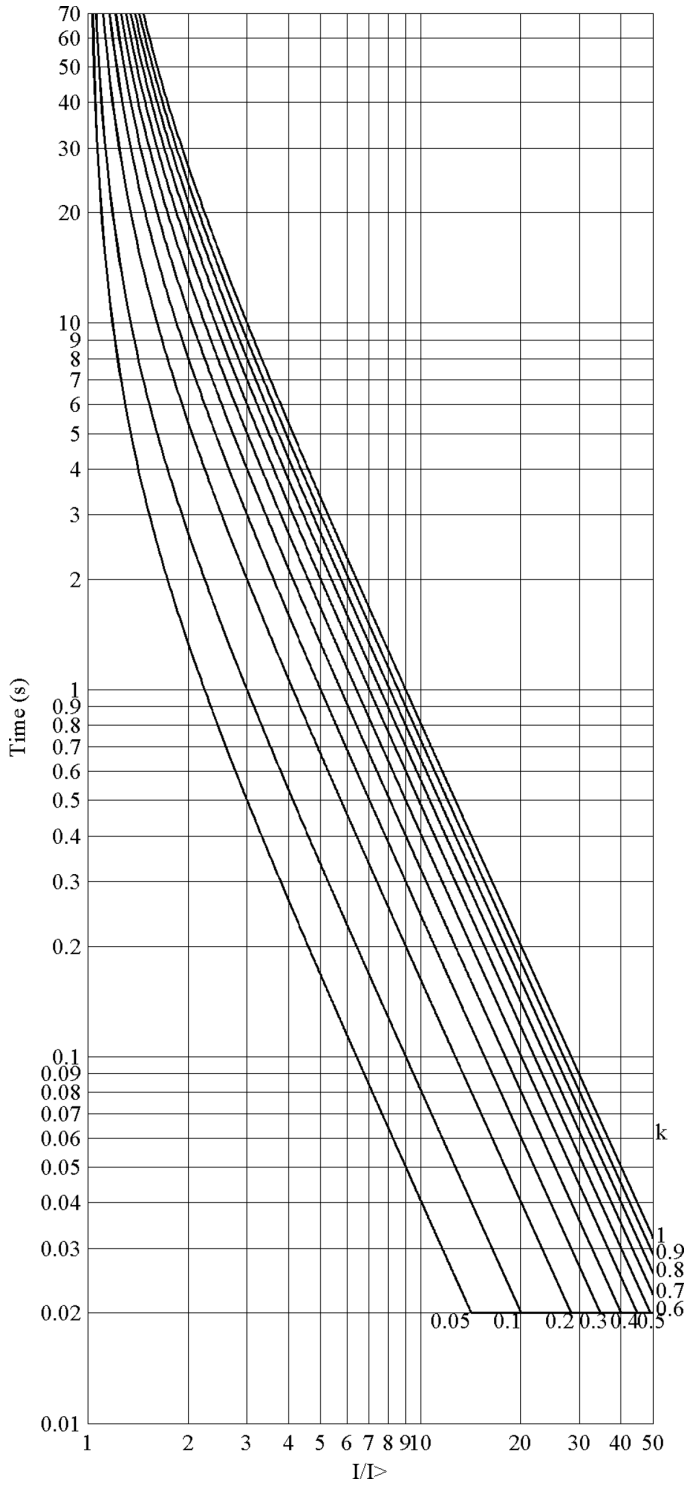

Figure 297: IEC Extremely inverse time characteristics

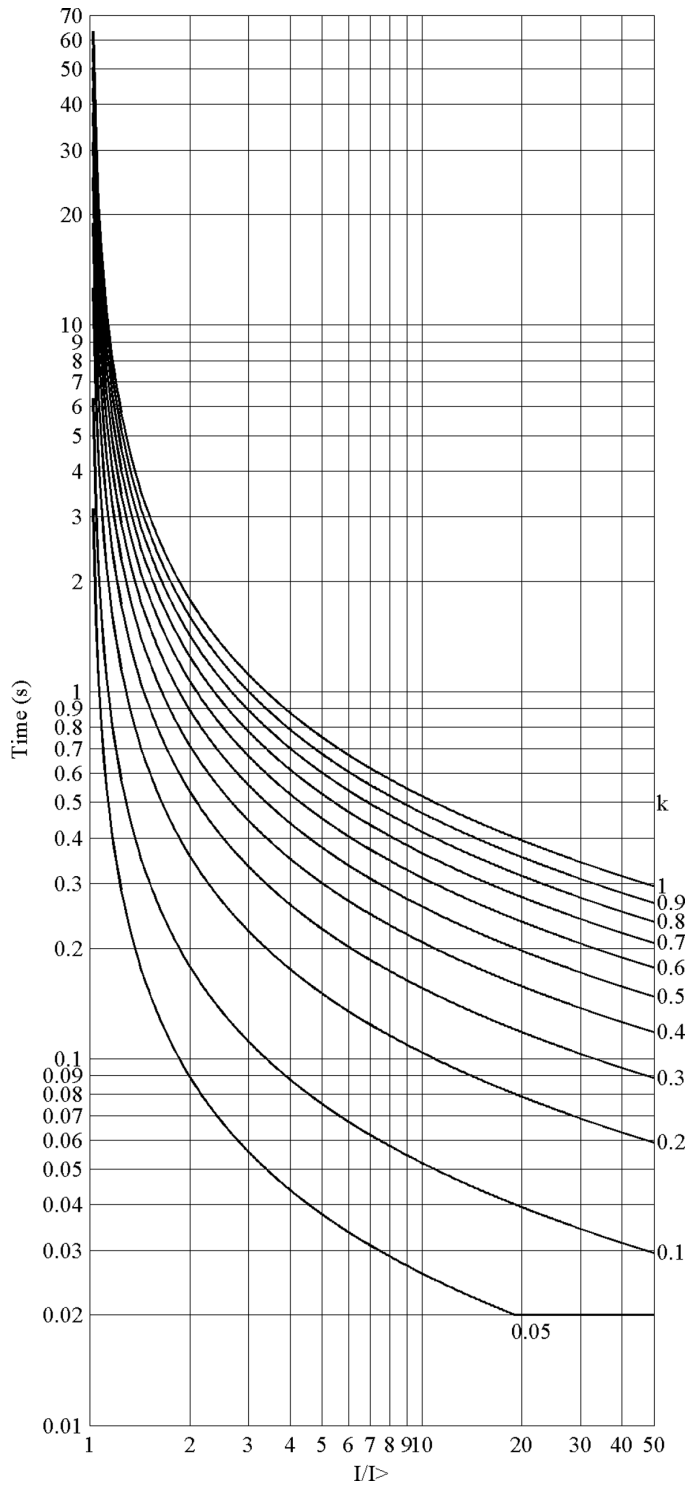

Figure 298: IEC Short time inverse time characteristics

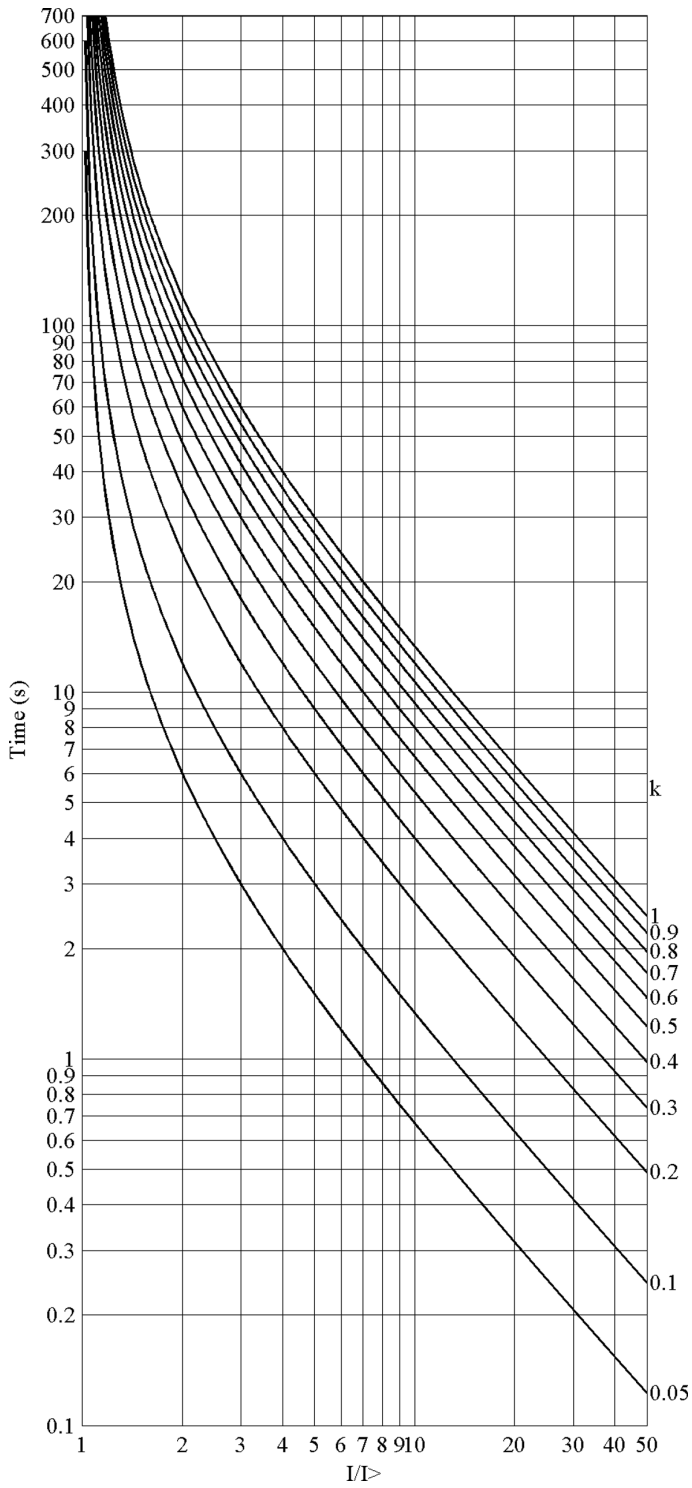

Figure 299: IEC Long time inverse time characteristics

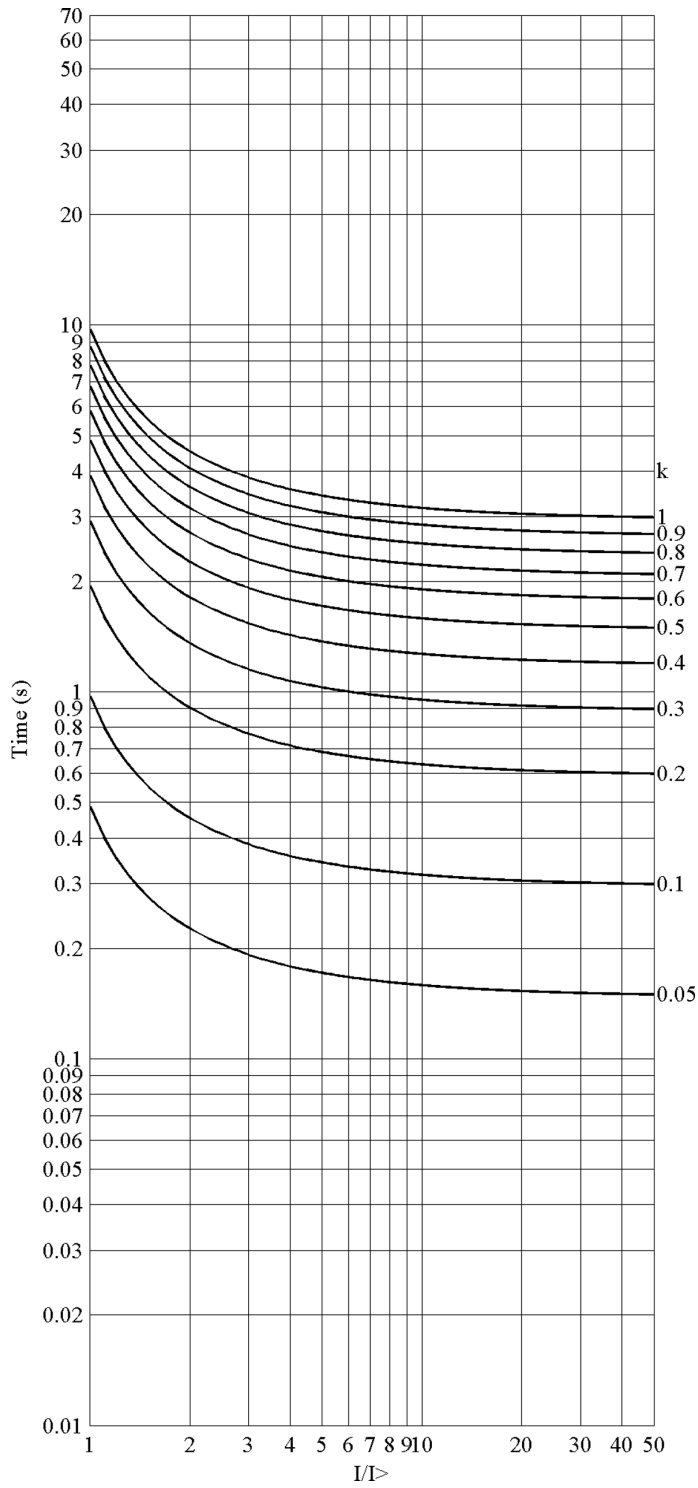

Figure 300: RI-type inverse time characteristics

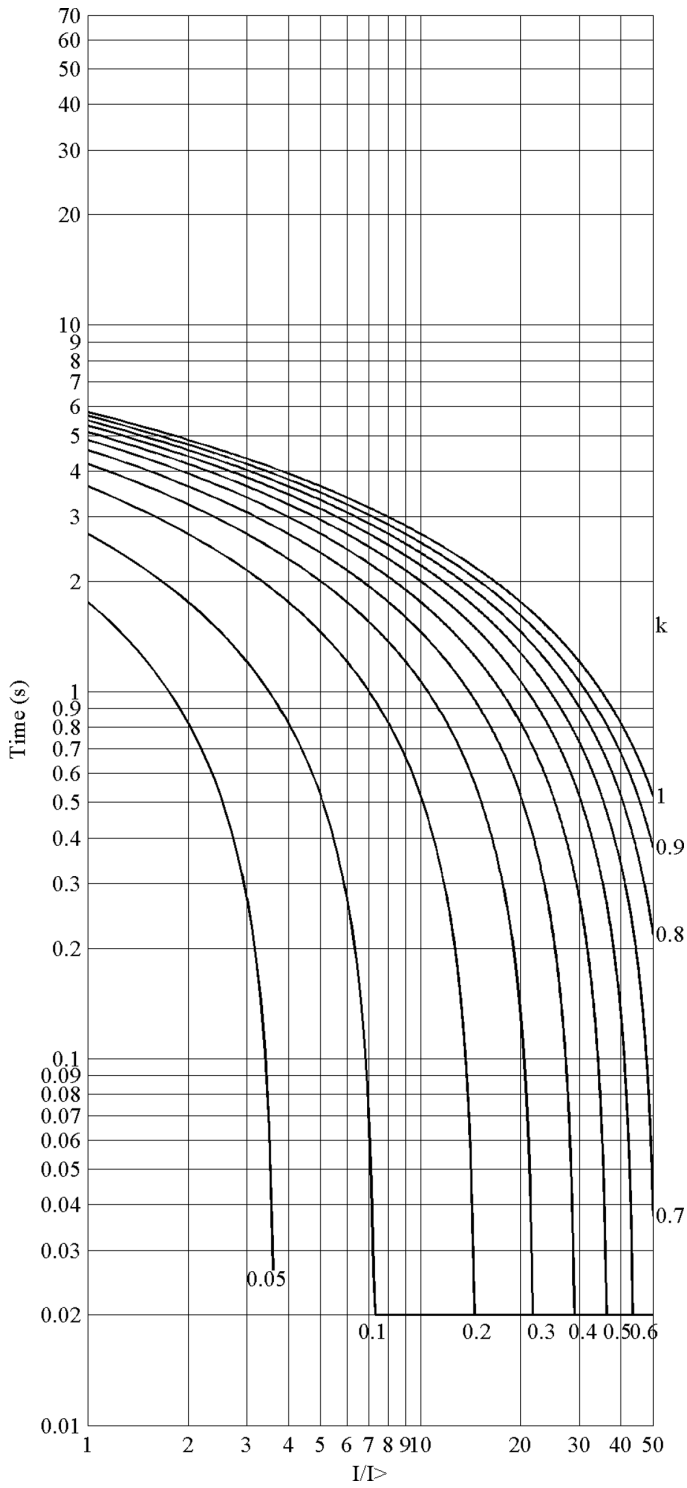

Figure 301: RD-type inverse time characteristics

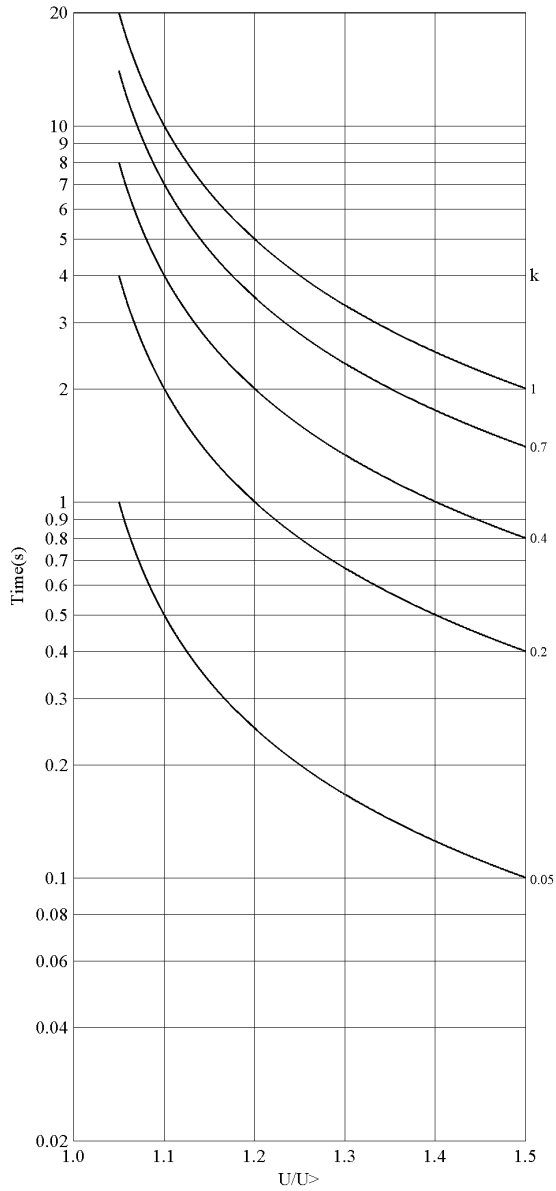

Figure 302: Inverse curve A characteristic of overvoltage protection

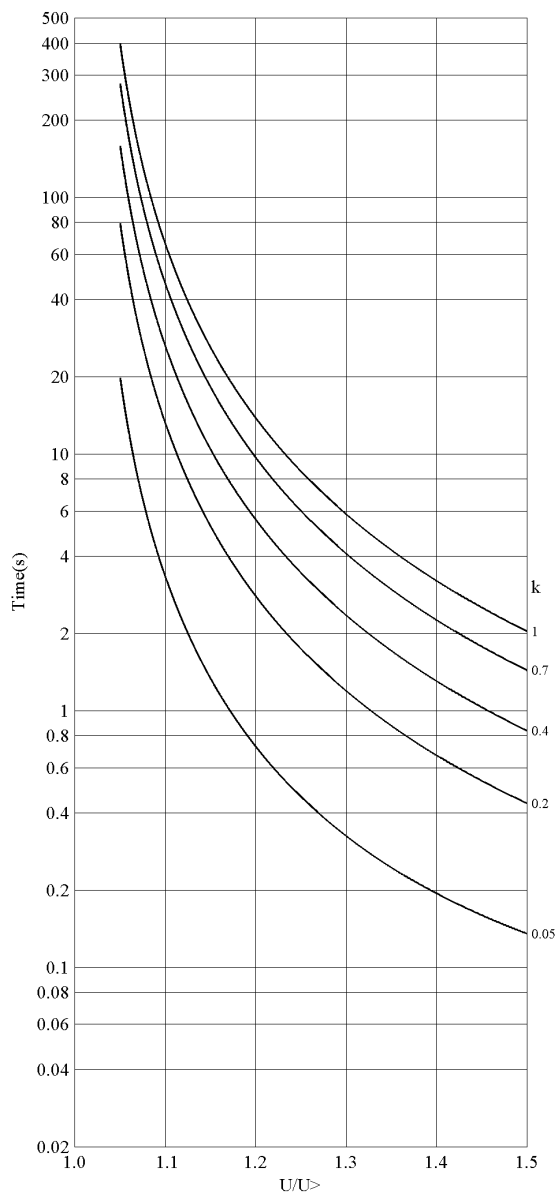

Figure 303: Inverse curve B characteristic of overvoltage protection

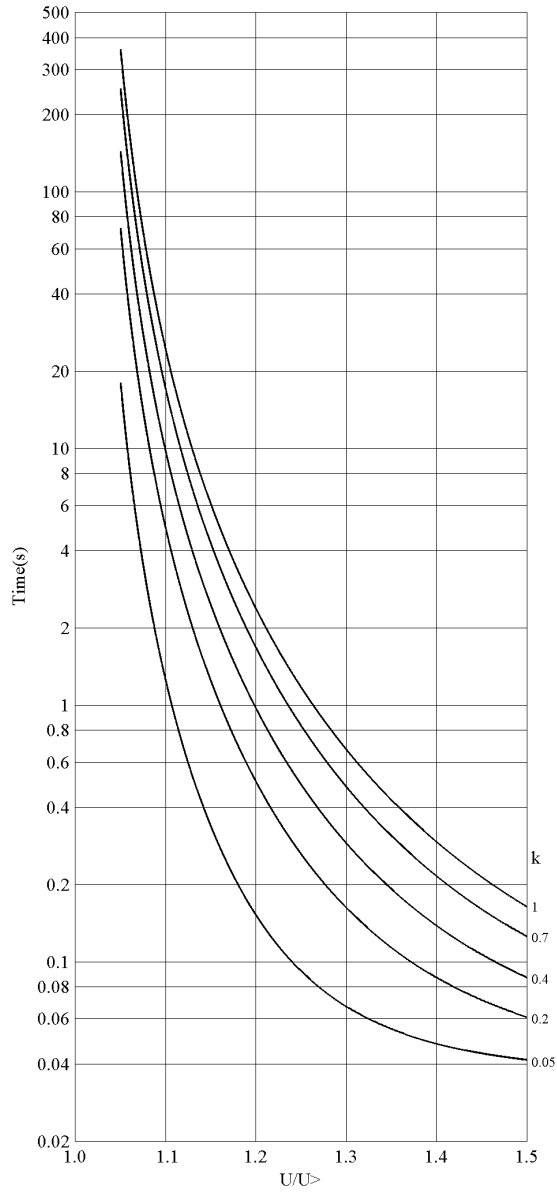

Figure 304: Inverse curve C characteristic of overvoltage protection

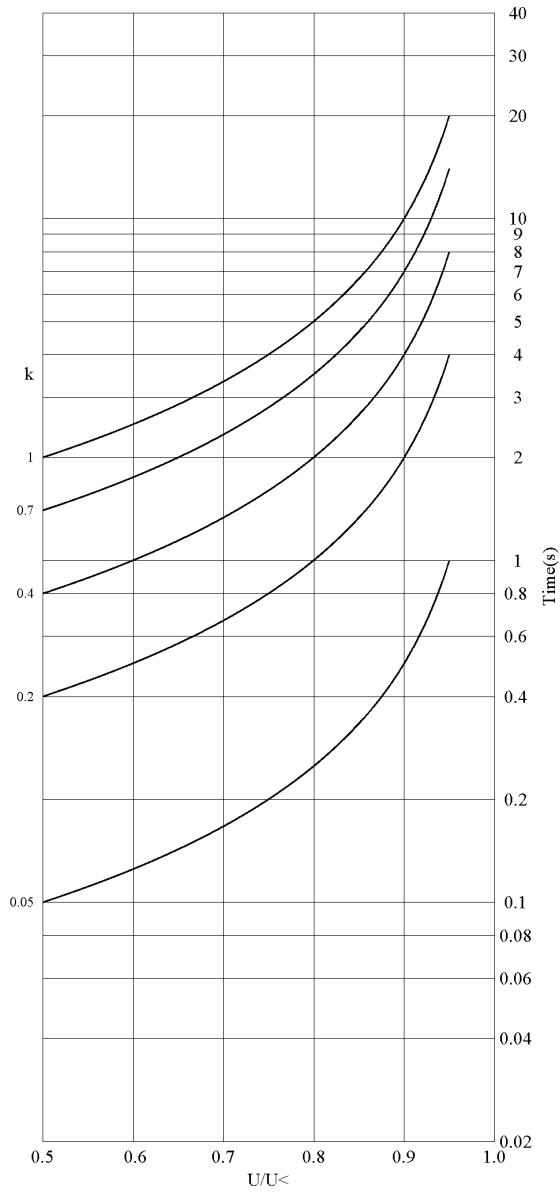

Figure 305: Inverse curve A characteristic of undervoltage protection

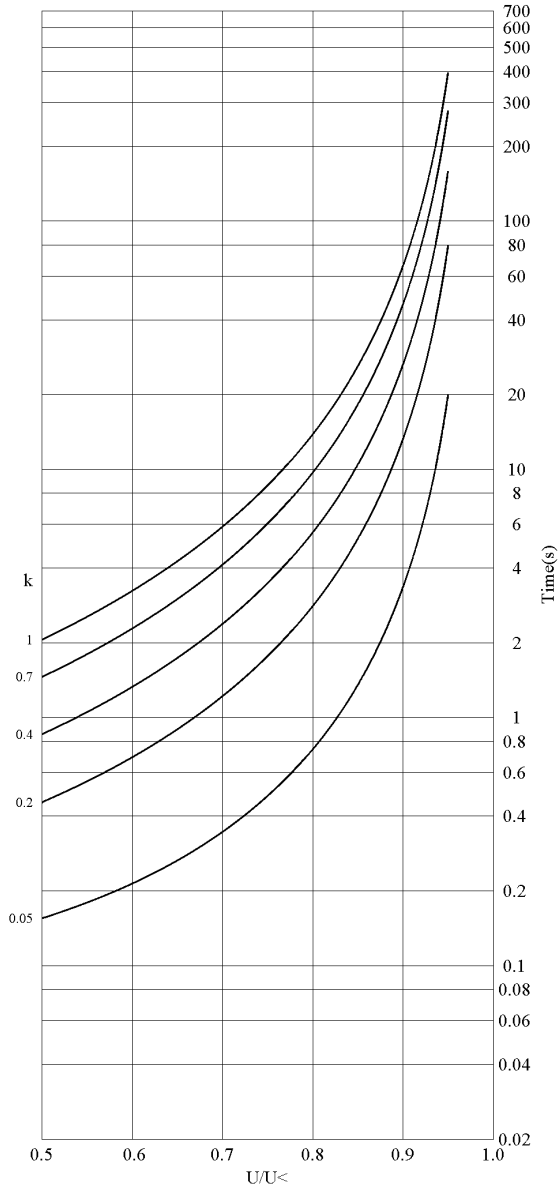

Figure 306: Inverse curve B characteristic of undervoltage protection

Section 21 Glossary

AC	Alternating current
ACC	Actual channel
ACT	Application configuration tool within PCM600
A/D converter	Analog-to-digital converter
ADBS	Amplitude deadband supervision
AI	Analog input
ANSI	American National Standards Institute
AR	Autoreclosing
ASCT	Auxiliary summation current transformer
ASD	Adaptive signal detection
ASDU	Application service data unit
AWG	American Wire Gauge standard
BBP	Busbar protection
BFOC/2,5	Bayonet fibre optic connector
BFP	Breaker failure protection
BI	Binary input
BOS	Binary outputs status
BR	External bistable relay
BS	British Standards
CB	Circuit breaker
CCITT	Consultative Committee for International Telegraph and Telephony. A United Nations-sponsored standards body within the International Telecommunications Union.
CCVT	Capacitive Coupled Voltage Transformer
Class C	Protection Current Transformer class as per IEEE/ ANSI
CMPPS	Combined megapulses per second
CMT	Communication Management tool in PCM600
CO cycle	Close-open cycle
COMTRADE	Standard format according to IEC 60255-24
COT	Cause of transmission
CPU	Central processing unit
CR	Carrier receive
CRC	Cyclic redundancy check
CROB	Control relay output block
CS	Carrier send
CT	Current transformer
CU	Communication unit
CVT	Capacitive voltage transformer

DAR	Delayed autoreclosing
DARPA	Defense Advanced Research Projects Agency (The US developer of the TCP/IP protocol etc.)
DBDL	Dead bus dead line
DBLL	Dead bus live line
DC	Direct current
DFC	Data flow control
DFT	Discrete Fourier transform
DHCP	Dynamic Host Configuration Protocol
DI	Digital input
DLLB	Dead line live bus
DNP	Distributed Network Protocol as per IEEE Std 1815-2012
DR	Disturbance recorder
DRAM	Dynamic random access memory
DRH	Disturbance report handler
DTT	Direct transfer trip scheme
EHV network	Extra high voltage network
EIA	Electronic Industries Association
EMC	Electromagnetic compatibility
EMF	Electromotive force
EMI	Electromagnetic interference
EnFP	End fault protection
EPA	Enhanced performance architecture
ESD	Electrostatic discharge
F-SMA	Type of optical fibre connector
FAN	Fault number
FCB	Flow control bit; Frame count bit
FOX 20	Modular 20 channel telecommunication system for speech, data and protection signals
FOX 512/515	Access multiplexer
FOX 6Plus	Compact time-division multiplexer for the transmission of up to seven duplex channels of digital data over optical fibers
FTP	File Transfer Protocol
FUN	Function type
GCM	Communication interface module with carrier of GPS receiver module
GDE	Graphical display editor within PCM600
GI	General interrogation command
GIS	Gas-insulated switchgear
GOOSE	Generic object-oriented substation event
GPS	Global positioning system
GSAL	Generic security application

GSE	Generic substation event
HDLC protocol	High-level data link control, protocol based on the HDLC standard
HFBR connector type	Plastic fiber connector
HMI	Human-machine interface
HSAR	High speed autoreclosing
HV	High-voltage
HVDC	High-voltage direct current
IDBS	Integrating deadband supervision
IEC	International Electrical Committee
IEC 61869-2	IEC Standard, Instrument transformers
IEC 60870-5-103	Communication standard for protective equipment. A serial master/slave protocol for point-to-point communication
IEC 61850	Substation automation communication standard
IEC 61850-8-1	Communication protocol standard
IEEE	Institute of Electrical and Electronics Engineers
IEEE 802.12	A network technology standard that provides 100 Mbits/s on twisted-pair or optical fiber cable
IEEE P1386.1	PCI Mezzanine Card (PMC) standard for local bus modules. References the CMC (IEEE P1386, also known as Common Mezzanine Card) standard for the mechanics and the PCI specifications from the PCI SIG (Special Interest Group) for the electrical EMF (Electromotive force).
IEEE 1686	Standard for Substation Intelligent Electronic Devices (IEDs) Cyber Security Capabilities
IED	Intelligent electronic device
I-GIS	Intelligent gas-insulated switchgear
Instance	When several occurrences of the same function are available in the IED, they are referred to as instances of that function. One instance of a function is identical to another of the same kind but has a different number in the IED user interfaces. The word "instance" is sometimes defined as an item of information that is representative of a type. In the same way an instance of a function in the IED is representative of a type of function.
IP	<ol style="list-style-type: none"> 1. Internet protocol. The network layer for the TCP/IP protocol suite widely used on Ethernet networks. IP is a connectionless, best-effort packet-switching protocol. It provides packet routing, fragmentation and reassembly through the data link layer. 2. Ingression protection, according to IEC standard
IP 20	Ingression protection, according to IEC standard, level 20
IP 40	Ingression protection, according to IEC standard, level 40
IP 54	Ingression protection, according to IEC standard, level 54
IRF	Internal failure signal
IRIG-B:	InterRange Instrumentation Group Time code format B, standard 200
ITU	International Telecommunications Union
LAN	Local area network
LCD	Liquid crystal display
LDD	Local detection device

LED	Light-emitting diode
LNT	LON network tool
MCB	Miniature circuit breaker
MVAL	Value of measurement
NCC	National Control Centre
NOF	Number of grid faults
NUM	Numerical module
OCO cycle	Open-close-open cycle
OCP	Overcurrent protection
OLTC	On-load tap changer
OTEV	Disturbance data recording initiated by other event than start/pick-up
OV	Over-voltage
Overreach	A term used to describe how the relay behaves during a fault condition. For example, a distance relay is overreaching when the impedance presented to it is smaller than the apparent impedance to the fault applied to the balance point, that is, the set reach. The relay “sees” the fault but perhaps it should not have seen it.
PCI	Peripheral component interconnect, a local data bus
PCM600	Protection and control IED manager
PC-MIP	Mezzanine card standard
POR	Permissive overreach
POTT	Permissive overreach transfer trip
Process bus	Bus or LAN used at the process level, that is, in near proximity to the measured and/or controlled components
PSM	Power supply module
PST	Parameter setting tool within PCM600
PT ratio	Potential transformer or voltage transformer ratio
PUTT	Permissive underreach transfer trip
RCA	Relay characteristic angle
RISC	Reduced instruction set computer
RMS value	Root mean square value
RS422	A balanced serial interface for the transmission of digital data in point-to-point connections
RS485	Serial link according to EIA standard RS485
RTC	Real-time clock
RTU	Remote terminal unit
SA	Substation Automation
SBO	Select-before-operate
SC	Switch or push button to close
SCL	Short circuit location
SCS	Station control system
SCADA	Supervision, control and data acquisition

SCT	System configuration tool according to standard IEC 61850
SDU	Service data unit
SMA connector	Subminiature version A, A threaded connector with constant impedance.
SMT	Signal matrix tool within PCM600
SMS	Station monitoring system
SNTP	Simple network time protocol – is used to synchronize computer clocks on local area networks. This reduces the requirement to have accurate hardware clocks in every embedded system in a network. Each embedded node can instead synchronize with a remote clock, providing the required accuracy.
SOF	Status of fault
SPA	Strömberg protection acquisition, a serial master/slave protocol for point-to-point communication
SRY	Switch for CB ready condition
ST	Switch or push button to trip
Starpoint	Neutral point of transformer or generator
SVC	Static VAr compensation
TC	Trip coil
TCS	Trip circuit supervision
TCP	Transmission control protocol. The most common transport layer protocol used on Ethernet and the Internet.
TCP/IP	Transmission control protocol over Internet Protocol. The de facto standard Ethernet protocols incorporated into 4.2BSD Unix. TCP/IP was developed by DARPA for Internet working and encompasses both network layer and transport layer protocols. While TCP and IP specify two protocols at specific protocol layers, TCP/IP is often used to refer to the entire US Department of Defense protocol suite based upon these, including Telnet, FTP, UDP and RDP.
TEF	Time delayed earth-fault protection function
TLS	Transport Layer Security
TM	Transmit (disturbance data)
TNC connector	Threaded Neill-Concelman, a threaded constant impedance version of a BNC connector
TP	Trip (recorded fault)
TPZ, TPY, TPX, TPS	Current transformer class according to IEC
TRM	Transformer Module. This module transforms currents and voltages taken from the process into levels suitable for further signal processing.
TYP	Type identification
UMT	User management tool
Underreach	A term used to describe how the relay behaves during a fault condition. For example, a distance relay is underreaching when the impedance presented to it is greater than the apparent impedance to the fault applied to the balance point, that is, the set reach. The relay does not “see” the fault but perhaps it should have seen it. See also Overreach.

UTC	Coordinated Universal Time. A coordinated time scale, maintained by the Bureau International des Poids et Mesures (BIPM), which forms the basis of a coordinated dissemination of standard frequencies and time signals. UTC is derived from International Atomic Time (TAI) by the addition of a whole number of "leap seconds" to synchronize it with Universal Time 1 (UT1), thus allowing for the eccentricity of the Earth's orbit, the rotational axis tilt (23.5 degrees), but still showing the Earth's irregular rotation, on which UT1 is based. The Coordinated Universal Time is expressed using a 24-hour clock, and uses the Gregorian calendar. It is used for aeroplane and ship navigation, where it is also sometimes known by the military name, "Zulu time." "Zulu" in the phonetic alphabet stands for "Z", which stands for longitude zero.
UV	Undervoltage
WEI	Weak end infeed logic
VT	Voltage transformer
3I₀	Three times zero-sequence current. Often referred to as the residual or the earth-fault current
3U₀	Three times the zero sequence voltage. Often referred to as the residual voltage or the neutral point voltage

ABB AB
Grid Automation Products
SE-721 59 Västerås, Sweden
Phone +46 (0) 21 32 50 00

www.abb.com/protection-control



Scan this QR code to visit our website