

907 PC 339

Programming and Test Software

Safety Manual

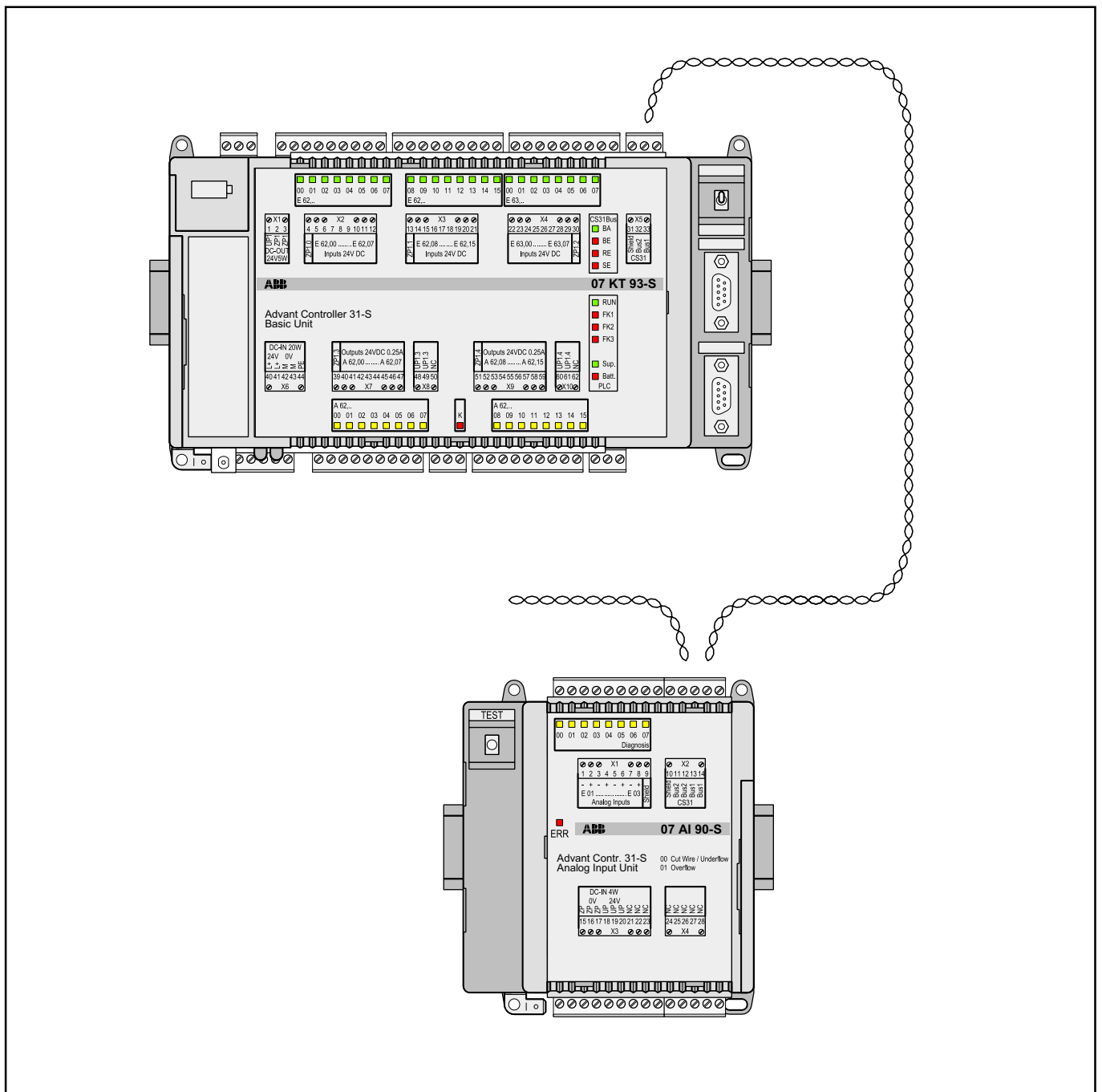

Table of Contents

1	Structure of the Advant Controller 31-S	1-1	3	Hardware planning	3-1
1.1	Minimum equipment	1-2	3.1	Preconditions	3-1
1.2	Hardware components for the Advant Controller 31-S	1-3	3.1.1	Reaction times	3-2
1.2.1	Safety-related binary and analog input and output modules for AC31-S	1-3	3.1.2	Calculating the maximum settings for the PLC cycle time	3-2
1.2.2	Non-safety-related modules for the Advant Controller 31-S	1-3	3.1.3	Inputs and outputs of the central unit 07 KT 94-S	3-2
1.2.3	Communication modules for networking	1-4	3.1.4	Networking interface and ARCNET interface	3-2
1.3	Programming software	1-4	3.1.5	Starting the PLC cycle	3-2
1.4	Documentation	1-5	3.1.6	Devices connected to the interfaces COM1 and COM2	3-2
2	Technical system data	2-1	3.1.7	Process and supply voltage	3-2
	Operating and ambient conditions	2-2	3.2	Addressing the safety-related I/O modules (setting the module address)	3-3
	Voltage ratings	2-2	3.3	Configuring the I/O modules	3-4
	Stored energy time on power failure	2-2	3.3.1	Possible AC31-S module addresses in relation to the central unit 07 KT 94 R2171	3-4
	Temperature	2-2	3.3.2	Configuration data 07 DI 90-S	3-5
	Humidity	2-2	3.3.3	Configuration data 07 DO 90-S	3-5
	Atmospheric pressure	2-2	3.3.4	Configuration data 07 AI 90-S	3-6
	Creepage distances and clearances	2-2	3.3.5	Example for a configuration	3-6
	Test voltage	2-2	3.4	Lightning protection / wiring concept	3-8
	Electromagnetic compatibility	2-2	3.4.1	Lightning protection concept	3-8
	Mechanical data	2-3	3.4.1.1	Connecting the low-voltage system	3-8
	Interfaces	2-3	3.4.1.2	Connecting the electronic equipment	3-8
	CS31 system bus	2-4	3.4.2	Wiring concept	3-9
	Wiring	2-4	3.4.3	Using the Advant Controller 31-S in networks of overvoltage category III (e.g. in road traffic signal systems according to DIN VDE 0832)	3-11
	Bus topology	2-5	3.5	Behaviour on power ON	3-11
	Earthing	2-6	3.6	Behaviour in case of errors on the safety-related I/O modules	3-11
	Bus cycle time and data security	2-7			
	Bus cycle time	2-7			
	Data security	2-8			
	Replacement of modules on the CS31 system bus	2-8			
	Mechanical dimensions of the safety-related I/O modules	2-9			

4	Binary input module 07 DI 90-S, safety-related	4-1	6	Analog input module 07 AI 90-S, safety-related	6-1
	Intended purpose	4-1		Intended purpose	6-1
	Indicators and operating elements on the front panel	4-2		Indicators and operating elements on the front panel	6-2
	Functional description	4-2		Functional description	6-2
	Electrical connection	4-3		Electrical connection	6-4
	Addressing (setting the module address)	4-6		Addressing (setting the module address)	6-6
	Auxiliary and diagnosis functions	4-7		Auxiliary and diagnosis functions	6-7
	Start-up behaviour	4-7		Start-up behaviour	6-7
	Diagnosis at the module	4-7		Diagnosis at the module	6-7
	Technical data	4-8		Technical data	6-8
	Installation and dimensions	4-9		Installation and dimensions	6-9
5	Binary output module 07 DO 90-S, safety-related	5-1			
	Intended purpose	5-1			
	Indicators and operating elements on the front panel	5-2			
	Functional description	5-2			
	Electrical connection	5-3			
	Addressing (setting the module address)	5-5			
	Auxiliary and diagnosis functions	5-6			
	Start-up behaviour	5-6			
	Diagnosis at the module	5-6			
	Technical data	5-7			
	Installation and dimensions	5-9			

1 Structure of the Advant Controller AC31-S

Contents

1.1	Minimum equipment	1-2
1.2	Hardware components for the Advant Controller 31-S	1-3
1.2.1	Safety-related binary and analog input and output modules for AC31-S	1-3
1.2.2	Non-safety-related modules for the Advant Controller 31-S	1-4
1.3	Programming Software	1-4
1.4	Documentation	1-5

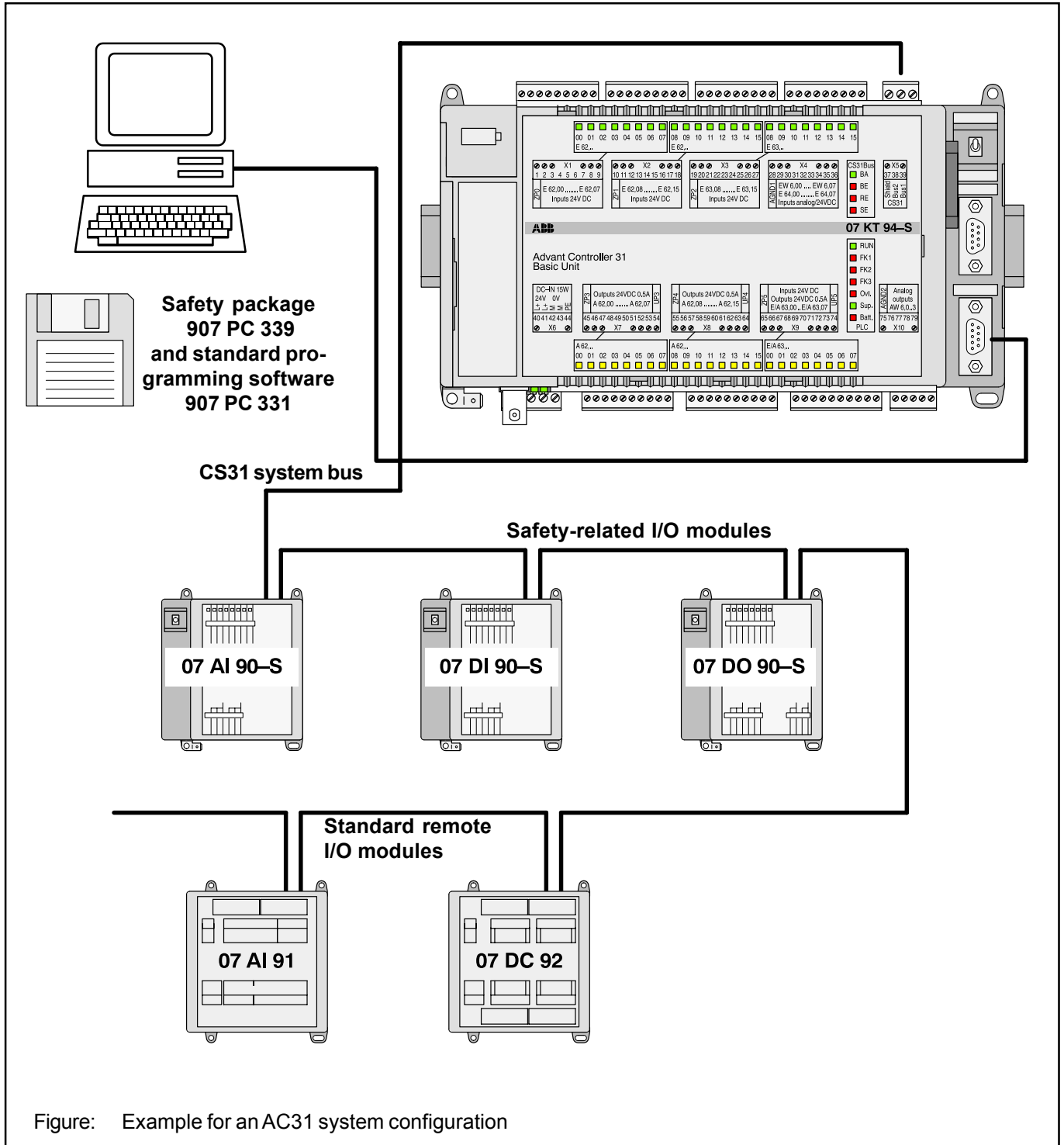

Figure: Example for an AC31 system configuration

1.1 Minimum equipment

For the setup of a safety-related automation system with AC31-S, the following equipment is required besides the programming software 907 PC 331 and the safety package 907 PC 339:

Central unit	07 KT 94-S R2161
Safety-related I/O modules	
Binary input module	07 DI 90-S: 8 binary inputs
Binary output module	07 DO 90-S: 8 binary outputs
Analog input module	07 AI 90-S: 4 analog inputs

Process supply voltage:

For the process supply, a 24 V DC power supply unit conforming to the following standards is required:

EN 60950	(Informationstechnik) / (Information technology)
EN 61000-4-5	Klasse 3 / Class 3
VDE 0805	(Sicherheit) / (Safty)

Power supply units see chapter 1.2.1

Non-safety-related modules:

All modules containing a CS31 system bus connection which are mentioned in the documentations "System description of Advant Controller 31" and "System description of ABB Procontic CS31" (see page 1-5 in this volume) can be used.

1.2 Hardware components for the Advant Controller 31-S

1.2.1 Safety-related binary and analog input and output modules AC31-S

Type	Brief description	Order number
07 DI 90-S	Binary input module, 8 inputs 24 V DC, safety-related	GJR5250900R202
07 DO 90-S	Binary output module, 8 outputs 24 V DC, safety-related	GJR5250800R202
07 AI 90-S	Analog input module, 4 inputs 4...20 mA, safety-related	GJR5251200R202

Central unit 07 KT 94-S R2161

07 KT 94-S R2161		GJR5252100R2161
------------------	--	-----------------

System cables

07 SK 90	Interface cable for connection of KT 94-S R2161 to the PC, 25/9 poles, length 5 m	GJR5250200R0001
----------	---	-----------------

Accessories

Type	Brief description	Order number
07 LE 90	Lithium battery module	GJR5250700R0001

For the process supply, a 24 V DC power supply unit conforming to the following standards is required:

EN 60950	(Informationstechnik) / (Information technology)
EN 61000-4-5	Klasse 3 / Class 3
VDE 0805	(Sicherheit) / (Safety)

Power supply units for installation in switch cabinets

Type: 07 NG 32 R1
Order No.: GJV3 0756 01 R0001

Power supply unit,
primary: 115/230 V AC, secondary: 24 V DC / 2,5 A

Type: 07 NG 34 R1
Order No.: GJV3 0756 02 R0001

Power supply unit,
primary: 115/230 V AC, secondary: 24 V DC / 5 A

Type: 07 NG 35 R1
Order No.: GJV3 0756 03 R0001

Power supply unit,
primary: 230/400 V 3-phase AC, secondary: 24 V DC / 10 A

Type: 07 NG 36 R1
Order No.: GJV3 0756 04 R0001

Power supply unit,
primary: 230/400 V 3-phase AC, secondary: 24 V DC / 20 A

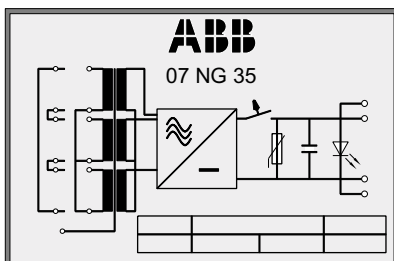

1.2.2 Non-safety-related modules for the Advant Controller 31-S

All modules which have a CS31 system bus connection by standard can be used with the safety-related modules.

The modules are listed in the current technical price list.

1.2.3 Communication modules for networking

All couplers which contain a networking interface by standard can be used. The couplers are listed in the current technical price list.

Safety-related data transfer via these couplers between two or more central units is **prohibited**.

1.3 Programming Software

The programming software is not part of the certificate. Therefore, applications designed with this software have

to be verified in accordance to this Safety Manual.

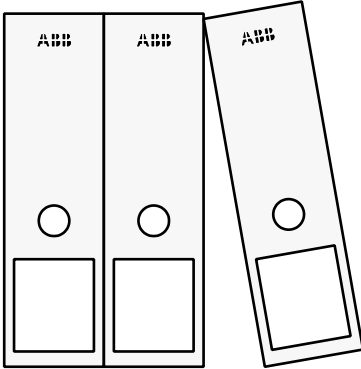

907 PC 33

PC programming and test software for IL, LD and FBD.

Documentation: General part of the programming interface without software (for information about software, refer to the system-specific part of 907 PC 331).

- German
- English

GJP 520 3900 R 0302

GJP 520 4000 R 0302

907 PC 331

PC programming and test software for IL, LD and FBD.

Documentation: System-specific part (including the software on floppy disk) for Advant Controller 31 and ABB Procontic T200 (communication processor 07 KP 62).

- German
- English

GJP 520 4500 R 0402

GJP 520 4600 R 0402

907 PC 339

Additional packet with safety-related functions AC31-S for the programming and test software 907 PC 331. Includes the software on floppy disk and the safety manual.

- German
- English

GJP 520 7500 R 0102

GJP 520 7600 R 0102

1.4 Documentation

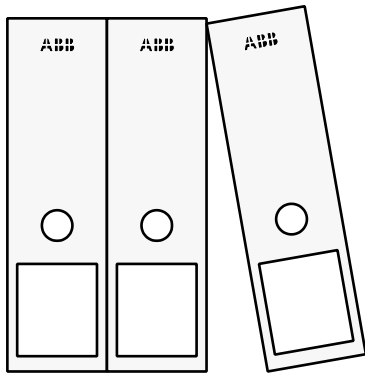

System description

Advant Controller 31

Complete hardware documentation in one file.

General part, hardware, operating instructions, planning instructions (central units 07 KT 94).

- German
- English

1SAC 131 699 R 0101

1SAC 131 699 R 0201

System description

ABB Procontic CS31

Complete hardware documentation in one file.

General part, hardware, operating instructions, planning instructions (central units 07 KR 31, 07 KT 31, 07 KR 91, 07 KT 92, 07 KT 94).

- German
- English

GATS 131 699 R 1002

FPTN 440 004 R 2001

2 Technical System Data

The relevant product standard for the Advant Controller 31 control system is EN 61131-2 (corresponds to IEC 1131-2).

Contents

Operating and ambient conditions	2-2
Voltage ratings	2-2
Stored energy time on power failure	2-2
Temperature	2-2
Humidity	2-2
Atmospheric pressure	2-2
Creepage distances and clearances	2-2
Test voltages	2-2
Electromagnetic compatibility	2-2
Mechanical data	2-3
Interfaces	2-3
CS31 system bus	2-4
Wiring	2-4
Bus topology	2-5
Earthing	2-6
Bus cycle time and data security	2-8
Bus cycle time	2-9
Data security	2-9
Replacement of modules on the CS31 system bus	2-9
Mechanical dimensions of the safety-related I/O modules	2-10
Mechanical dimensions of the safety-related 07 KT 94-S	2-11

Operating and ambient conditions (valid for all safety-related modules)

Voltages

24 V DC	process and supply voltage absolute limits ripple	24 V DC (+ 20 %, - 15 %, without ripple) 19.2 V ... 30 V incl. ripple $\leq 5 \%$
120 V AC	supply voltage frequency	120 V AC (+ 10 %, - 15 %) 50 Hz (+ 5 %, - 5 %) or 60 Hz (+ 5 %, - 5 %)
230 V AC	supply voltage frequency	230 V AC (+ 10 %, - 15 %) 50 Hz (+ 5 %, - 5 %) or 60 Hz (+ 5 %, - 5 %)

Allowed interruptions of power supply

DC supply	interruption ≤ 10 ms, time between 2 interruptions ≥ 1 s
AC supply	interruption ≤ 0.5 periods, time between 2 interruptions ≥ 1 s

Temperature

If the 07 KT 94-S basic unit is used, it must be made sure, that the cabinet temperature does not fall below 0° C.

operation	0 °C ... + 55 °C
storage	- 25 °C ... + 75 °C
transport	- 25 °C ... + 75 °C

Humidity

5...95 %, without condensation

Air pressure

operation	≥ 800 hPa/ ≤ 2000 m
storage	≥ 660 hPa/ ≤ 3500 m

Creepage distances and clearances

The creepage distances and clearances meet Overvoltage category II, pollution severity 2

Insulation test voltages

230 V circuits (mains, 230 V inputs/outputs) against other circuitry	2500 V
120 V circuits (mains) against other circuitry	1500 V
24 V circuits (supply, 24 V inputs/outputs), when electrically isolated against other circuitry	500 V
CS31 bus against other circuitry	500 V

Electromagnetic compatibility

- Immunity
against electrostatic discharge (ESD)
 - electrostatic voltage in case of air discharge 8 kV
 - electrostatic voltage in case of contact discharge 6 kV
- Immunity against
the influence of radiated interference (CW radiated)
 - test field strength according to EN 61000-4-3
10 V/m
- Immunity
against transient interference voltages (burst) according to EN 61000-4-4
 - supply voltage units (AC/DC) 2 kV
 - digital inputs/outputs (24 V DC) 1 kV
 - digital inputs/outputs (120/230 V AC) 2 kV
 - analog inputs/outputs 1 kV
 - CS31 system bus 2 kV
 - serial interfaces (COM:) 0,5 kV
 - ARCNET 0,5 kV

- Immunity against pulse voltages (Surge)
 - DC supply
 - unshielded 24 V I/O
 - shielded lines
- Immunity against the influence of line-conducted interferences (CW conducted)
 - test voltage
- Radio disturbance

according to EN 61000-4-5
 1 / 0,5 kV
 0,5 / 0,5 kV
 1 kV

according to EN 61000-4-6
 10 V

according to EN 55011 radio interference level A and according to EN 55022 radio interference level A (only for communication modules)

Mechanical data

Wiring method / terminals

for plug-in base ECZ

for removable terminal blocks (big)

for removable terminal blocks (small)

screw-type terminals for normal and Phillips-head screwdrivers, conductor cross section max. 2 - 2.5 mm²
 screw-type terminals for normal screwdrivers, conductor cross section max. 2.5 mm²
 screw-type terminals for normal screwdrivers, conductor cross section max. 1.5 mm²

Degree of protection

IP 20

Housing

according to UL 94

Vibration resistance

all three axes
 10 Hz...57 Hz continuous: 0,0375 mm
 peak: 0,075 mm
 57 Hz...150 Hz continuous: 0.5 g
 peak: 1.0 g

Shock resistance

all three axes
 15 g, 11 ms, half-sinusoidal

Mounting of the modules

DIN rail according to DIN EN 50022, only for plug-in base ECZ:

mounting with screws

width 35 mm, depth 15 mm
 depths 7.5 mm and 15 mm
 screws with a diameter of 4 mm

Interfaces

between the basic unit and the input/output modules,

EIA RS-485 (CS31 system bus)

for the programming units and the connection to a terminal, 9-pole D-SUB, female

EIA RS-232

CS31 system bus

Wiring

Bus line

construction	2 cores, twisted, with common shield
conductor cross section	$\geq 0.22 \text{ mm}^2$ (24 AWG)
recommendation	0.5 mm^2 , corresponds to $\varnothing 0.8 \text{ mm}$
twisting rate	> 10 per meter (symmetrically twisted)
core insulation	polyethylene (PE)
resistance per core	$\leq 100 \Omega / \text{km}$
characteristic impedance	approx. 120Ω (100... 150 Ω)
Capacitance between the cores	$< 55 \text{ nF} / \text{km}$ (if higher, the max. bus length must be reduced)
terminating resistors	$120 \Omega \frac{1}{4} \text{ W}$
bus length	max. 500 m

Recommended bus line

Steuerleitung DUE 4001
Kabelmetall electro GmbH,
Schafhofstraße 35,
D-90411 Nürnberg
Telefon 0911-5207-0

Twinax-Leitung H 8106
BICC Deutschland GmbH,
Düsseldorfer Straße 186,
D-41460 Neuss
Telefon 02101-26143

Twinax-Leitung 9271
Belden Electronics GmbH,
Fuggerstraße 2,
D-41468 Neuss
Telefon 02101-35041

Twinax-Leitung HF 3094
Dätwyler Elektro GmbH,
Auf der Roos 4-12,
D-65795 Hattersheim a. M.
Telefon 06190-2011-2015

Remarks

Any other equivalent cable can be used. Standard telephone cables with PE insulation and a core diameter of $\geq 0,6 \text{ mm}$ generally fulfil the requirements.

Cables with PVC core insulation and a core diameter of $\geq 0,6 \text{ mm}$ can be used up to a length of approx. 250 m. In this case, the bus terminating resistor is approx. 100Ω .

Bus topology

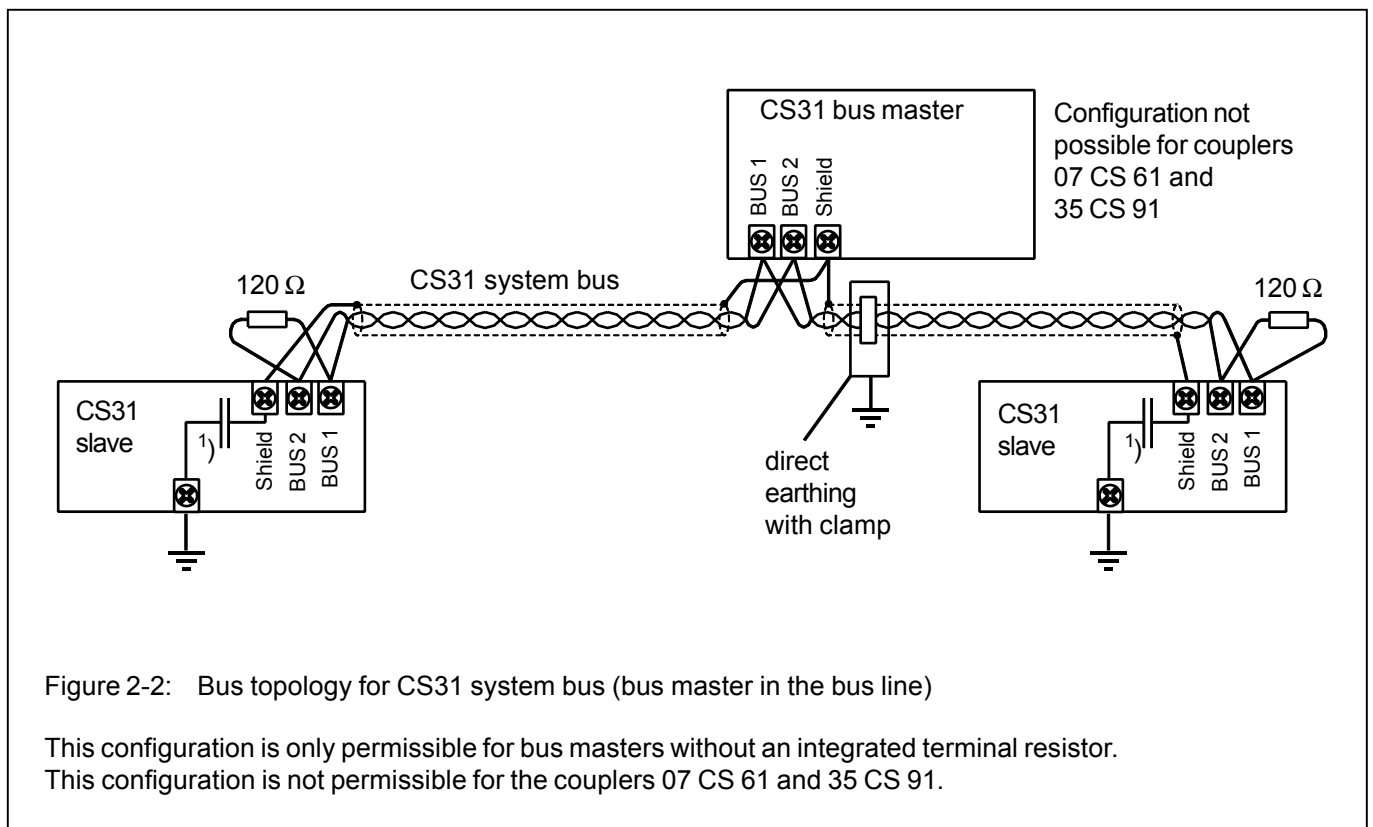
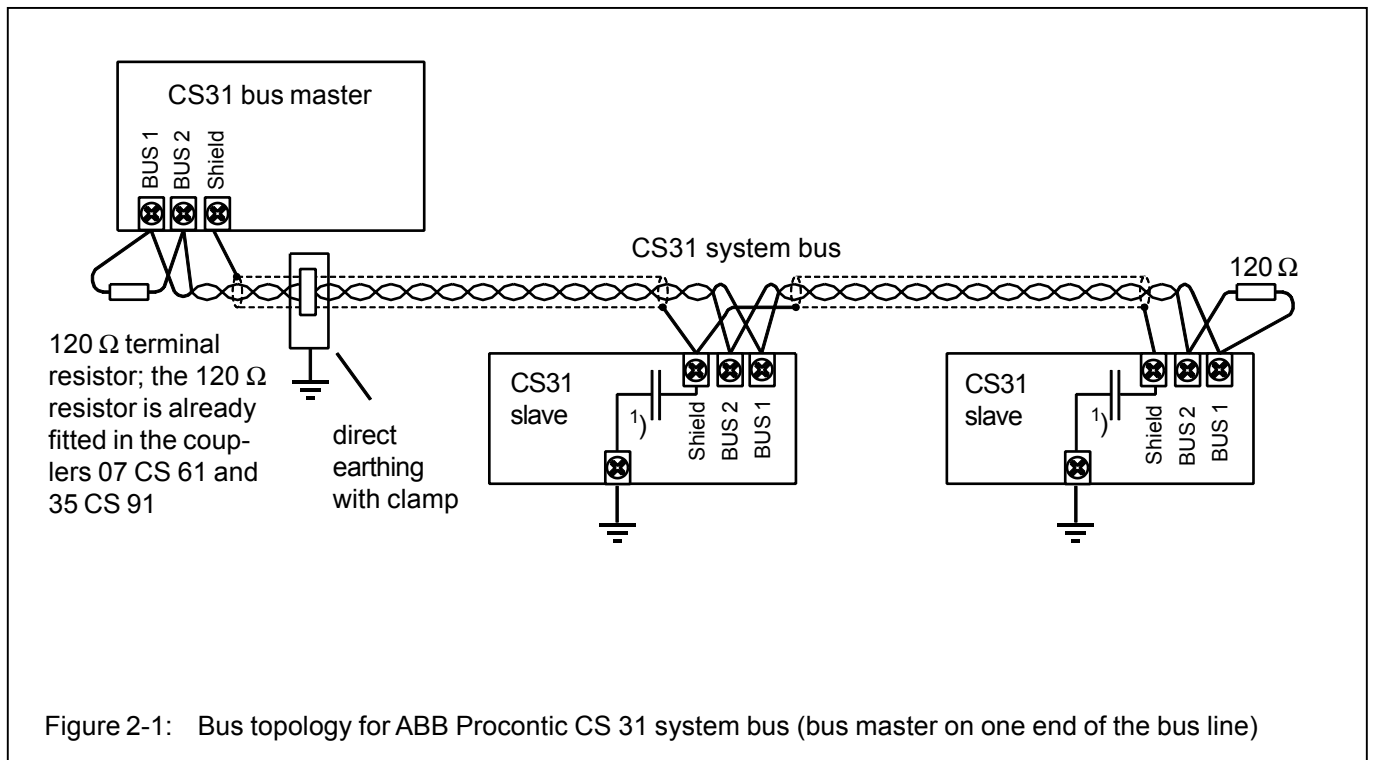

1) The capacitor is only existent for modules which require the ECZ plug-in base.

Wiring with spur lines is not permissible.

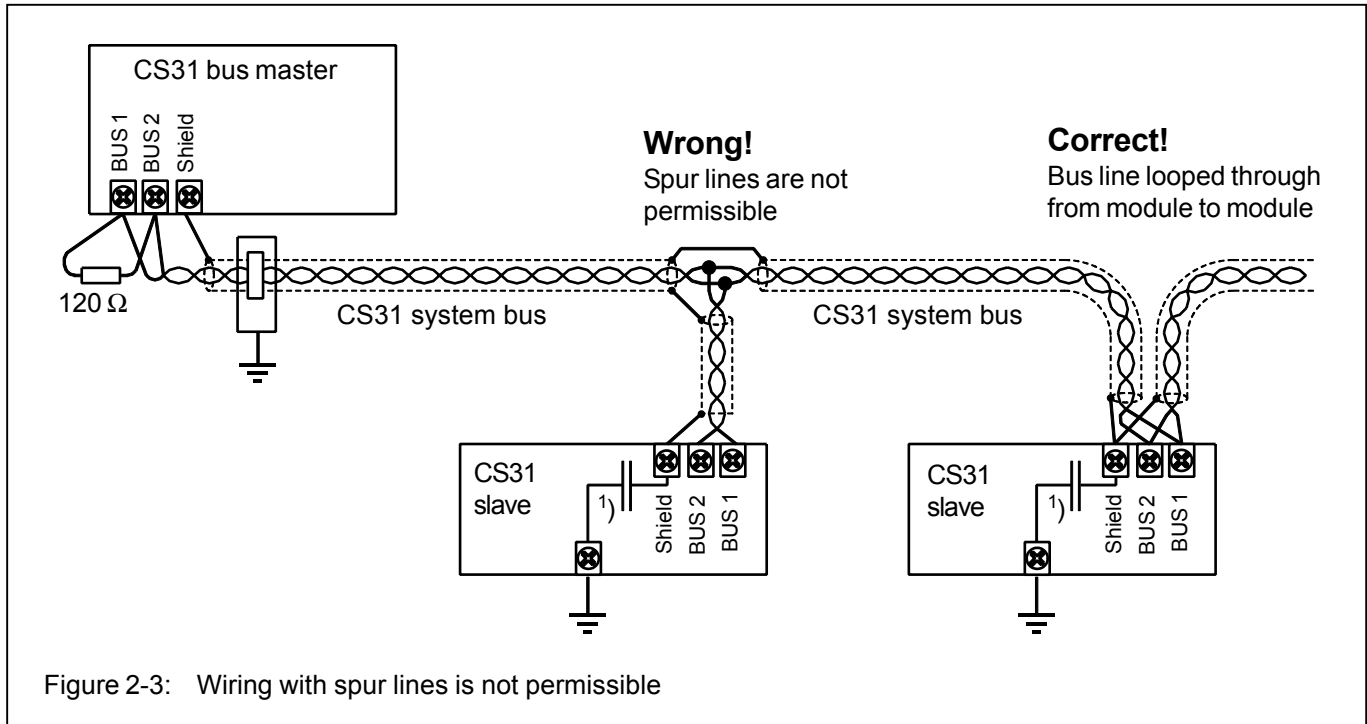

Earthing

The cable shields must be earthed as directly as possible, so that interferences are arrested.

Case a:

Several control cabinets; current-conducting metallic connections (steel construction, earthing bars, etc.) are used to ensure that no potential differences arise. Direct earthing must be implemented.

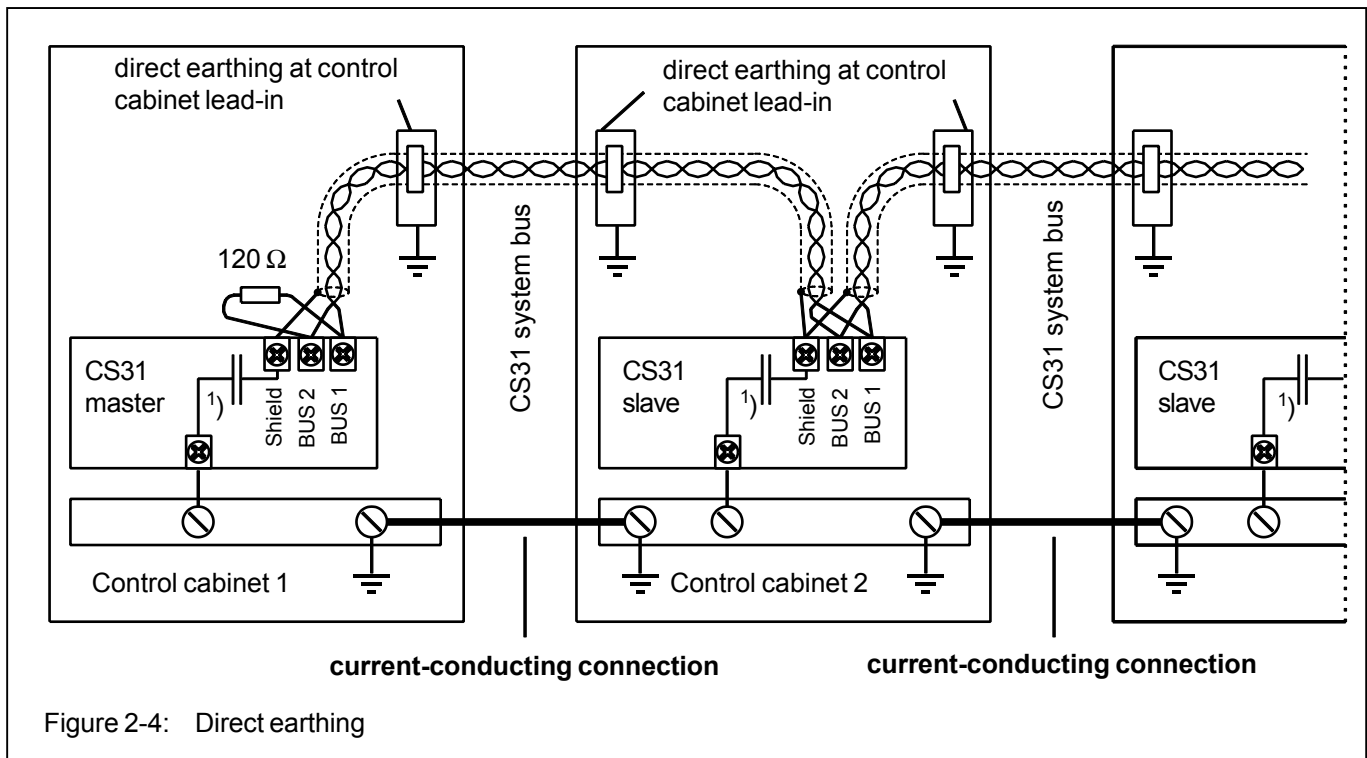

1) The capacitor is only existent for modules which require the ECZ plug-in base.

Case b:
 Several control cabinets; the system parts are connected to each other by non-conducting connections.

Capacitive earthing must be implemented in order to prevent equalizing currents flowing through the cable shields.

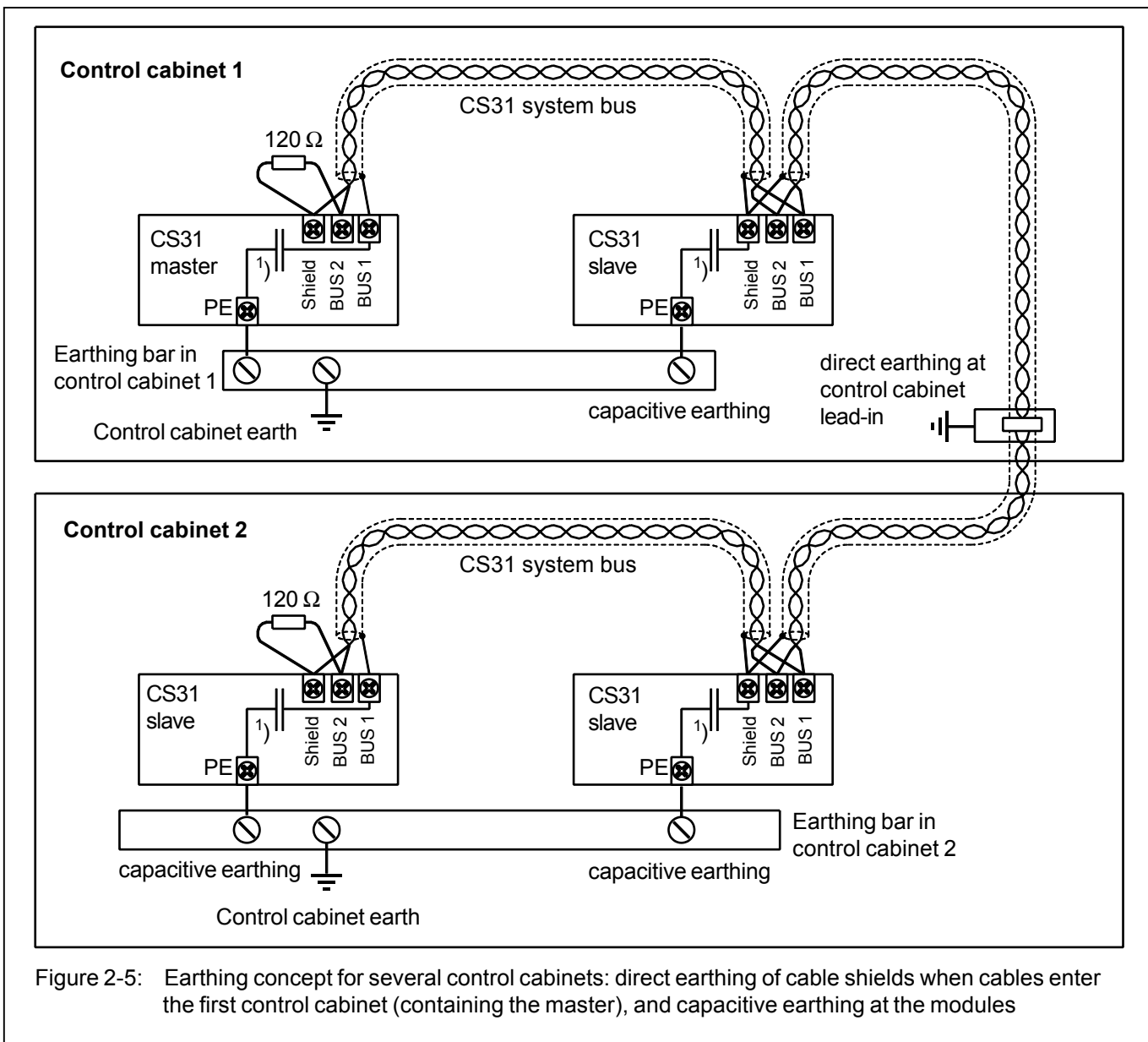

Figure 2-5: Earthing concept for several control cabinets: direct earthing of cable shields when cables enter the first control cabinet (containing the master), and capacitive earthing at the modules

1) The capacitor is only existent for series 30 modules which require the ECZ plug-in base.

connections should be as short as possible (max. 25 cm) and have a cross-section as large as possible (min. 2.5 mm²).

The following applies in all cases: The entire length of the shield-to-plug-in-base and the plug-in-base-to-earthing-bar

VDE 0160 requires that the shield must be earthed directly at least once per system.

Bus cycle time and data security

Module	Bus transmission time in μs
Digital input modules	
ICSI 08 D1	323
ICSI 08 E1	323
ICSI 08 E3	323
ICSI 08 E4	323
ICSI 16 D1	387
ICSI 16 E1	387
Digital output modules	
ICSO 08 R1	260
ICSO 08 Y1	260
ICSO 16 N1	340
Digital input/output modules	
ICSC 08 L1	387
ICFC 16 L1	516
ICSK 20 F1	452
ICSK 20 N1	452
07 DC 91 / ICDG 32 L1	516/590 (depending on configuration)
07 DI 92	516
07 DC 92	750/516 (depending on configuration)
IP65-I/O modules	
07 DK 93-I	387
07 DO 93-I	260
07 DI 93-I	387
Analog modules	
ICSM 06 A6	1162
ICSE 08 A6	1355
ICSE 08 B5	1355
ICSA 04 B5	700
ICST 08 A8	1355
ICST 08 A9	1355
07 AI 91 / ICDT 08 B5	1355
07 AC 91	2500
Couplers	
ICBG32L7	516
ICBG64L7	750
High-speed counter	
ICSF 08 D1	1300
Safety-related modules	
07 DI 90-S / 07 EB 90-S	590
07 DO 90-S / 07 AB 90-S	750
07 AI 90-S / 07 EA 90-S	1050

Module	Bus transmission time in μs
Keyboard/LED controller module 07 TC 90/91 / TCK 64 16 E/A 32 E/A	387 750
Basic unit as slaves	
07 KR 31 / 07 KT 31	516 * 1)
07 KR 91 / KT 92 / KT 93 / KT 94	750 * 2)
	* = default
Typ. settings	
1) Send 2 bytes + receive 2 bytes (1 word)	516
2) Send 4 bytes + receive 4 bytes (2 word)	750
Send 8 bytes + receive 8 bytes (4 word)	1300
Send 12 bytes + receive 12 bytes (6 word)	1850
Send 8 words + receive 8 words	2500

Bus cycle time

In the following the bus cycle time t_b is explained. The terminal-to-terminal reaction time is the sum of several time values and will be explained in chapter 3 "Hardware planning" in volume 3. The bus cycle time is composed of:

- Base time 2 ms
During this time, the central unit carries out diagnosis and searches for newly added local modules.
- Bus transmission time per module:
The bus transmission time is described in volume 2 of the AC31 System Description (Order No. 1SAC131699 R0101) in chapter 1 "Bus cycle time and data security".
- Equation for the bus cycle time of CS31 modules:

Bus cycle time t_b = sum of the bus transmission times of the modules + base time (2 ms)

For system bus compatible modules manufactured by external companies, the bus transmission times are specified in the corresponding descriptions.

Example: 1 module 07 DI 90-S (590 μ s)
and
1 module 07 DO 90-S (750 μ s)
are employed on the CS31 system bus.
The bus transmission times of other AC31 modules can be found in the AC31 System Description in volume 2, chapter 1.4.

$$t_b = 590 \mu\text{s} + 750 \mu\text{s} + 2 \text{ ms} = 3,34 \text{ ms.}$$

Data security

The transmission protocol handles a maximum of 31 slaves (decentralized I/O modules) and one master - the central unit.

During the initialization cycle, the master queries all slaves which it can find thus determining the number and type of the individual modules.

All telegrams are terminated with a CRC check word (CRC8). Error security of the bus: Hamming distance 4.

Thus, the messages have the following format:

Request of the central unit:

Address No.	Data	CRC8
-------------	------	------

Reply of one of the I/O modules:

Data	CRC8
------	------

The bus master queries all existing modules subsequently in one cycle, carries out a diagnosis at one of the existing modules and then transmits a search command for newly added modules. In this way, it can, on the one hand, maintain a continuous diagnosis concerning the correct operation of the network and, on the other hand, include all modules which have been newly added.

The safety-related data between the central unit and the safety-related I/O modules are transferred in the "data section" of the CS31 system bus standard telegram, performing additional checks, e.g. the module address, the running number, the additional CRC8 checksum, etc.

The structure of the S telegrams is represented in the description of the S-CEs S_LEB, L_LEB, S_LEA, S_LAB and S_SAB in volume 5 "Connection elements library".

Replacement of modules on the CS31 system bus

- The 24 V DC supply voltage must be switched off prior to the replacement of a module.
- Before the installation of the new module, it must be checked whether the module requires an I/O configuration other than the factory setting. Here, the following items can be set:
 - for binary I/O modules, an input delay other than the factory setting,
 - for binary modules with combined I/O channels, these channels can be defined as only-inputs or only-outputs,
 - for binary modules, the cut wire (open circuit) monitoring at the inputs and outputs
 - for analog modules, input and output ranges other than the factory setting.
- The I/O configuration is realized via the CS31 system bus. For analog modules, also switches at the bottom of the housing must be set (see description of these modules).

To carry out I/O configuration via the CS31 system bus, see the descriptions of the central units and couplers in the chapter on I/O configuration.
- After a module has been replaced, the new module is automatically incorporated into the cycle by the central unit or the coupler. If the module is replaced during operation, a part of the error flags remain set and can be deleted, for example, by supplying power to the central unit.

Mechanical dimensions of the safety-related I/O modules

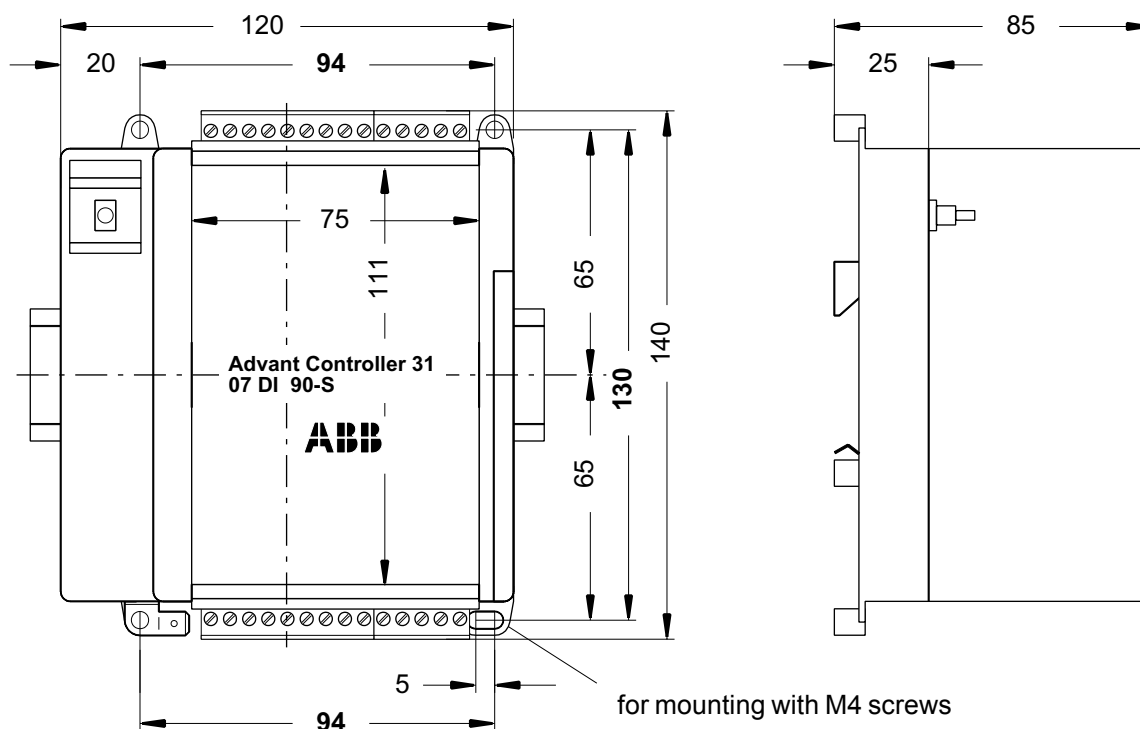

All dimensions in mm.

The module is 85 mm deep. If a DIN rail is used (according to DIN EN 50022-35, 15 mm deep), the mounting depth is increased by the overall depth of the rail.

Figure 2-6: 07 DI 90-S, 07 DO 90-S, 07 AI 90-S, mounting on a DIN rail or fixing with screws, outline dimensions, **dimensions for assembly bore holes are printed in bold.**

3 Hardware planning

Contents

3.1	Preconditions	3-1
3.2	Addressing of the safety-related I/O modules (setting the module address) ..	3-3
3.3	Configuring the I/O modules	3-4
3.3.1	Possible module addresses	3-4
3.3.2	Configuration data 07 DI 90-S	3-5
3.3.3	Configuration data 07 DO 90-S	3-5
3.3.4	Configuration data 07 AI 90-S	3-6
3.3.5	Example for a configuration	3-6
3.4	Lightning protection / wiring concept	3-8
3.4.1	Lightning protection	3-8
3.4.2	Wiring concept	3-9
3.4.3	Using the Advant Controller 31 in networks of overvoltage category III (e.g. in road traffic signal systems according to DIN VDE 0832)	3-11
3.5	Behaviour on power ON	3-11
3.6	Behaviour in case of errors on the safety-related I/O modules	3-11

3.1 Preconditions

For the planning of the Advant Controller 31-S, the AC31 planning directives apply for non-safety-related modules.

Additionally, the following planning regulations must be observed for the safety-related operation:

- The planning is generally to be made in accordance with the check list for the draft phase and realization phase (see volume 7).
 - The number of I/O ports is known after defining the safety-related and the non-safety-related signals. The user must provide an I/O reserve for further expansions. This will usually be within a size of plus 10 % referred to the I/O points already assigned.

- The result is a list with the number of safety-related I/O modules and non-safety-related I/O modules. For setting up the configuration, it must now be checked whether the required modules fit into one remote line with reference to the addresses and data volume. If necessary, several lines must be planned (see also example configuration).

In addition, the following items must be observed:

- Only one CS31 bus line per central unit 07 KT 94-S is possible.
- A maximum of 31 modules (including safety-related modules and non-safety-related modules) can be connected to the CS31 system bus.
- Generally only module addresses between 0 and 61 are permissible; 0 to 61 for bit modules and 0 to 6 for word modules.
- Note that some modules employ more than one address.
- The safety-related modules 07 DI 90-S, 07 DO 90-S and 07 AI 90-S can only be set to an address in the range between 0 to 31.
- For the planning, it must be observed that the error tolerance time (200 msec) must not be exceeded. This error tolerance time is determined by:
 - Input delay or output delay of the I/O module
 - Bus cycle time, to be calculated from the following table for S modules or the AC31 System Description (1SAC131699R0102, Volume2, chapter 1.4 "Bus cycle time") for standard modules.
 - Program cycle time, set in the flag KD0,0 (smallest adjustable cycle time = 1 ms; can be increased only in steps of 1 ms).

3.1.1 Reaction times

The input and output delay of the safety-related I/O modules can be found in this volume in the "Technical data" sections of the chapters 4 to 6.

- Terminal-to-terminal reaction time

$$t_{\text{React}} = \begin{aligned} &\text{Input delay (07 DI 90-S)} \\ &+ \text{Bus cycle time} \\ &+ 2 \times \text{Program cycle time} \\ &+ \text{Bus cycle time} \\ &+ \text{Output delay} \\ &\quad (07 DO 90-S) \end{aligned}$$

- Error reaction time in case of an external error

$$t_{\text{React}} = \begin{aligned} &\text{Monitoring time} \\ &\quad (\text{DI 90-S, DO 90-S, AI 90-S}) \\ &+ \text{Bus cycle time} \\ &+ 2 \times \text{Program cycle time} \\ &+ \text{Bus cycle time} \\ &+ \text{Output delay} \end{aligned}$$

- Error reaction time in case of an internal error

$$t_{\text{React}} = \begin{aligned} &\text{Monitoring time} \\ &\quad (\text{CE / S_LEB, S_LAB, S_LEA}) \\ &+ 2 \times \text{Program cycle time} \\ &+ \text{Bus cycle time} \\ &+ \text{Output delay} \end{aligned}$$

3.1.2 Calculating the maximum adjustable PLC cycle time

S module type	CS31 bus cycle time in μs
07 DI 90-S binary	590
07 DO 90-S binary	750
07 AI 90-S analog	1050

The module 07 DO 90-S requires a new telegram with a new running number at least every 100 ms. Otherwise it will switch off, sending an "internal error" message. The maximum PLC cycle time can be calculated as follows (the PLC cycle time is set in the internal flag KD0,0).

Equation:

- max. PLC cycle time =
100 ms - (2x Bus cycle time t_b) - 10 ms

Definition of parameters:

- 10 ms = Time reserve (safety)
- 100 ms = Monitoring time of the output module 07 DO 90-S

- Bus cycle time = see page 2-9 for calculation
- Note: The capacity utilization of the PLC system should be 80 % max.
- Determination of the capacity utilization: Command "AL" in terminal mode, specified in percent.

3.1.3 Inputs and outputs of the central unit 07 KT 94-S

The inputs and outputs of the central unit 07 KT 94-S may not be used for safety-related applications. This applies to:

E62,00...E62,15 and E63,08...E63,15
A62,00...A62,15

3.1.4 Networking interface and ARCNET interface

Safety-related data **must not** be exchanged with other systems via these interfaces.

3.1.5 Start of the PLC cycle

The PLC must not start processing the program until **all** the I/O modules are logged on. Thus, the system constant KW 0,9 must contain the number of all modules on the bus, e.g. KW 0,9 = +7.

3.1.6 Modules connected to the interfaces COM1 and COM2

All modules which are connected to these interfaces must be electrically safe and must not conduct any inadmissible voltages to these inputs in case of an error.

3.1.7 Process and supply voltage

The supply voltage should be 24 V DC (+ 20 %, - 15 %) (see also technical data in volume 2). Non-compliance of the tolerance limits can cause error signals of the input module 07 DI 90-S because the five signal levels defined are very close to each other (see volume 3, chapter 4 "Technical data").

Therefore it may be necessary to continuously check the supply voltage and to initiate a suitable reaction (e.g. acoustic warning signal or switching off) in case of an error (when the voltage exceeds the tolerance limits).

3.2 Addressing of the safety-related I/O modules (setting the module address)

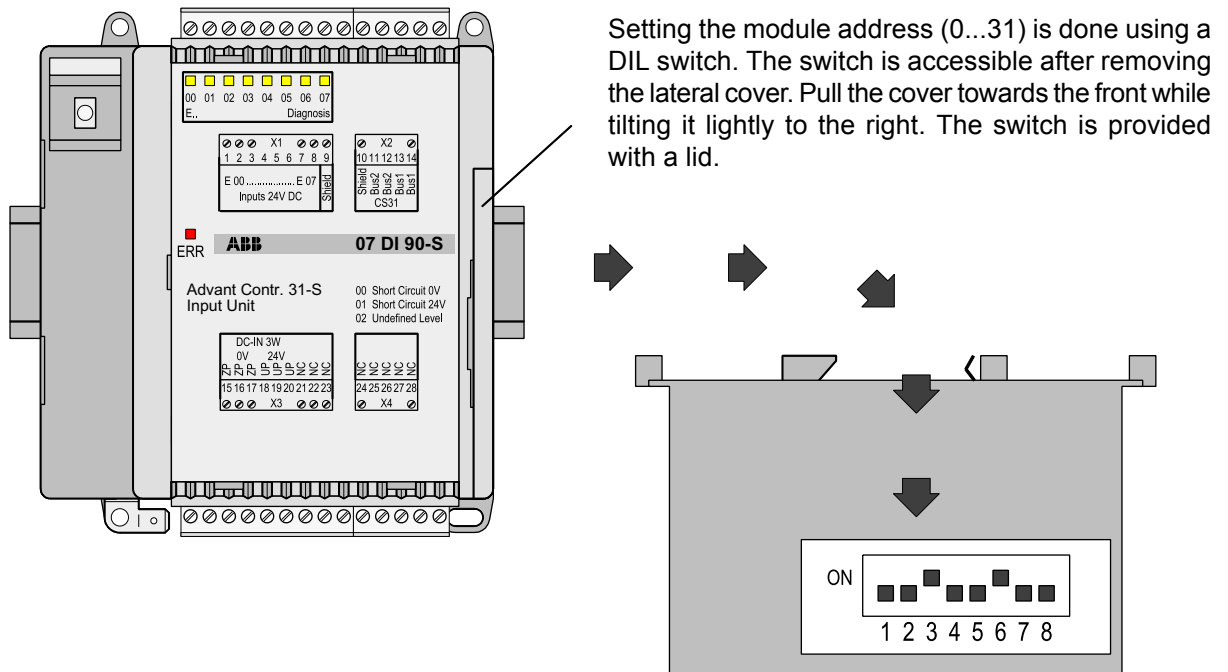

Meaning of the 8 switches:

Switch 1: must always be set to OFF

Switch 2: must always be set to OFF

Switch 3: Module address bit 4, significance 16

Switch 4: Module address bit 3, significance 8

Switch 5: Module address bit 2, significance 4

Switch 6: Module address bit 1, significance 2

Switch 7: Module address bit 0, significance 1

Switch 8: must always be set to OFF

The sum of the significance values of the switches in ON position is the set module address, e.g.:
switch 3 = ON, significance = 16 and
switch 6 = ON, significance = 2
results in module address 18.

Figure 3-1: Setting the module address using the DIL switch in the safety-related modules

3.3 Configuring the I/O modules

3.3.1 Possible AC31-S module addresses in relation to the central unit 07 KT 94-S R2161

	Binary inputs	Binary outputs	Analog inputs	Analog outputs
Range 1	E00,00 ⋮ ⋮ ⋮ E31,15	A00,00 + E00,00 ⋮ ⋮ ⋮ ⋮ ⋮ ⋮ A31,15 + E31,15	EW00,00 ⋮ ⋮ ⋮ EW05,15	AW00,00 ⋮ ⋮ ⋮ AW05,15
Range 2	E32,00 ⋮ ⋮ ⋮ E61,15	A32,00 ⋮ ⋮ ⋮ A61,15		
Range 3	E62,00 ⋮ ⋮ ⋮ E63,15	A62,00 ⋮ ⋮ ⋮ A63,15		
Range 4			EW06,00 ⋮ ⋮ ⋮ EW07,15	
Range 5				AW06,00 ⋮ ⋮ ⋮ AW06,15

Range 1: Safety-related modules can be configured only in this range. However, this range is also permissible for non-safety-related modules. The output module 07 DO 90-S occupies the addresses A x,x and E x,x (refer to chapter 3.3.3 in this volume).

Range 2: In this range only non-safety-related modules can be configured.

Range 3: Binary, non-safety-related inputs and outputs on the central unit and I/O of the high-speed counter.

Range 4: Analog inputs: Special range for the high-speed counter, reading the real-time clock and the status (see also appendix 7-1 of the AC31 hardware description).

Range 5: Analog outputs: Special range for the high-speed counter (see also appendix 7-1 of the AC31 hardware description).

3.3.2 Configuration data 07 DI 90-S (binary input module, 8 inputs)

- Number of occupied CS31 bus addresses: 4
- Possible address range: E 00,00 ... E 31,15

Example:

3 modules 07 DI 90-S are connected to the CS31 system bus.

1. module: address 00
2. module: address 04
3. module: address 08

The addressing does not have to be consecutively. The highest adjustable address is 31.

- Transmission time on CS31 system bus: 590 μ s
- max. number of such modules per CS31 line: 8
(32 addresses in range 1 divided by 4 addresses occupied per module)

Structure of the telegram (reading input status):

Address	Offset	High Byte	Low Byte
En,00... En, 15	0	Run. No.	Module addr.
En+1,00... En+1,15	1	Status byte	Data byte
En+2,00... En+2,15	2	not used	CRC8 byte
En+3,00... En+3,15	3	not used	not used

The input module 07 DI 90-S occupies 4 addresses on the CS31 system bus (e.g. E 10,00 occupies the addresses E 10,00 ... E 13,15).

3.3.3 Configuration data 07 DO 90-S (binary output module, 8 outputs)

- Number of occupied CS31 bus addresses: 2
- Caution:
This module occupies 2 output **and** 2 input addresses in the range of:
A 00,00 ... A 31,15
E 00,00 ... E 31,15

Example:

4 modules 07 DO 90-S are connected to the CS31 system bus.

1. module: address 0
2. module: address 2
3. module: address 4
4. module: address 8

The addressing does not have to be consecutively. The highest adjustable address is 31.

- Transmission time on CS31 system bus: 750 μ s
- max. number of such modules per CS31 line: 16
(32 addresses in range 1 divided by 2 addresses occupied per module)

Structure of the telegram (writing of outputs):

Address	Offset	High Byte	Low Byte
An,00... An, 15	0	Run. No.	Module addr.
An+1,00... An+1, 15	1	CRC8 byte	Status byte

The output module 07 DO 90-S occupies 2 addresses on the CS31 system bus (e.g. A 14,00 occupies also the addresses A 14,00 ... A 15,15).

Addresses which are already occupied by the module 07 DO 90-S may not be used any more for input modules (standard or safety-related modules).

Example:

Address set for 07 DO 90-S = 12

This will occupy

A 12,00 ... A 13,15 **and additionally**
E 12,00 ... E 13,15.

These addresses are restricted for the other input modules.

Structure of the telegram (play back of output status):

Address	Offset	High Byte	Low Byte
En,00... En, 15	0	Run. No.	Module addr.
En+1,00... En+1, 15	1	CRC8 byte	Status byte

The output module 07 DO 90-S occupies 2 addresses on the CS31 system bus (e.g. A 14,00 occupies also the addresses E 14,00 ... E 15,15).

3.3.4 Configuration data 07 AI 90-S (analog input module, 4 inputs)

- Number of occupied CS31 bus addresses: 1
- The module occupies one word address in the address range of:
EW 00,00 ... EW 05,15

Example:

2 modules 07 AI 90-S are connected to the CS31 system bus.

1. module: address 0
2. module: address 1

The addressing does not have to be consecutively. The highest adjustable address is 5.

- Transmission time on CS31 system bus: 1050 μ s
- max. number of such modules per CS31 line: 6 only addresses 00 to 05

Structure of the telegram (reading analog value):

Address	Offset	High Byte	Low Byte
EWn,00	0	Run. No.	Module addr.
EWn,01	1	Ch0 high	Ch0 low
EWn,02	2	Ch1 high	Ch1 low
EWn,03	3	Ch2 high	Ch2 low
EWn,04	4	Ch3 high	Ch3 low
EWn,05	5	CRC8 byte	Status byte

Ch = Channel = Analog channel

The analog input module 07 AI 90-S occupies one address on the CS31 system bus.

Please note that a maximum of 31 modules (including standard and safety-related modules) can be connected to the CS31 system bus.

3.3.5 Example for a configuration

- 3 modules 07 DI 90-S with a total of 24 binary safety-related inputs, selected addresses: 10, 14, 20
- 2 modules 07 AI 90-S with a total of 8 analog safety-related inputs, selected addresses: 01, 02
- 3 modules 07 DO 90-S with a total of 24 binary safety-related outputs, selected addresses: 04, 06, 08
- 2 modules 07 DI 92 with non-safety-related inputs, selected addresses: 24, 30

Calculation of the bus transmission time:

Quantity	Module type	Transm. time / module
3	07 DI 90-S	590 μ sec
2	07 AI 90-S	1050 μ sec
3	07 DO 90-S	750 μ sec
2	07 DI 92-S	516 μ sec

10 modules (< 31, thus ok)

The bus transmission time t_B (CS31 bus) is determined in order to check the maximum error reaction time. It is comprised as follows.

$$t_B = 3 * 590 \mu\text{sec} + 2 * 1050 \mu\text{sec} + 3 * 516 \mu\text{sec} + 2 * 323 \mu\text{sec} + \text{base time}$$

$$t_B = 1770 \mu\text{sec} + 2100 \mu\text{sec} + 1032 \mu\text{sec} + 646 \mu\text{sec} + 2000 \mu\text{sec} = 9152 \mu\text{sec}$$

Figure 3-2: Configuration table for the example

$$\begin{aligned} \text{Max. PLC cycle time} &= 100 \text{ ms} - (2 * t_B) - 10 \text{ ms} \\ &= 100 \text{ ms} - 18,304 \text{ ms} - 10 \text{ ms} \\ &= \text{approx. } 72 \text{ ms} \end{aligned}$$

(The PLC program must not require more than approx. 72 ms for one cycle).

$$\begin{aligned} \text{Terminal-terminal reaction time (refer to 3.1.1)} \\ &= 5 \text{ ms} + 9,152 \text{ ms} + (2 * 70 \text{ ms}) + 9,152 \text{ ms} + 8 \text{ ms} \\ &= \text{approx. } 172 \text{ ms} \end{aligned}$$

$$\begin{aligned} \text{Error reaction time in case of an external error (refer to 3.1.1)} \\ &= 9,152 \text{ ms} + (2 * 70 \text{ ms}) + 9,152 \text{ ms} + 8 \text{ ms} \\ &= \text{approx. } 166 \text{ ms} \end{aligned}$$

$$\begin{aligned} \text{Error reaction time in case of an internal error (refer to 3.1.1)} \\ &= (2 * 70 \text{ ms}) + 9,152 \text{ ms} + 8 \text{ ms} \\ &= \text{approx. } 157 \text{ ms} \end{aligned}$$

AC31-S central station

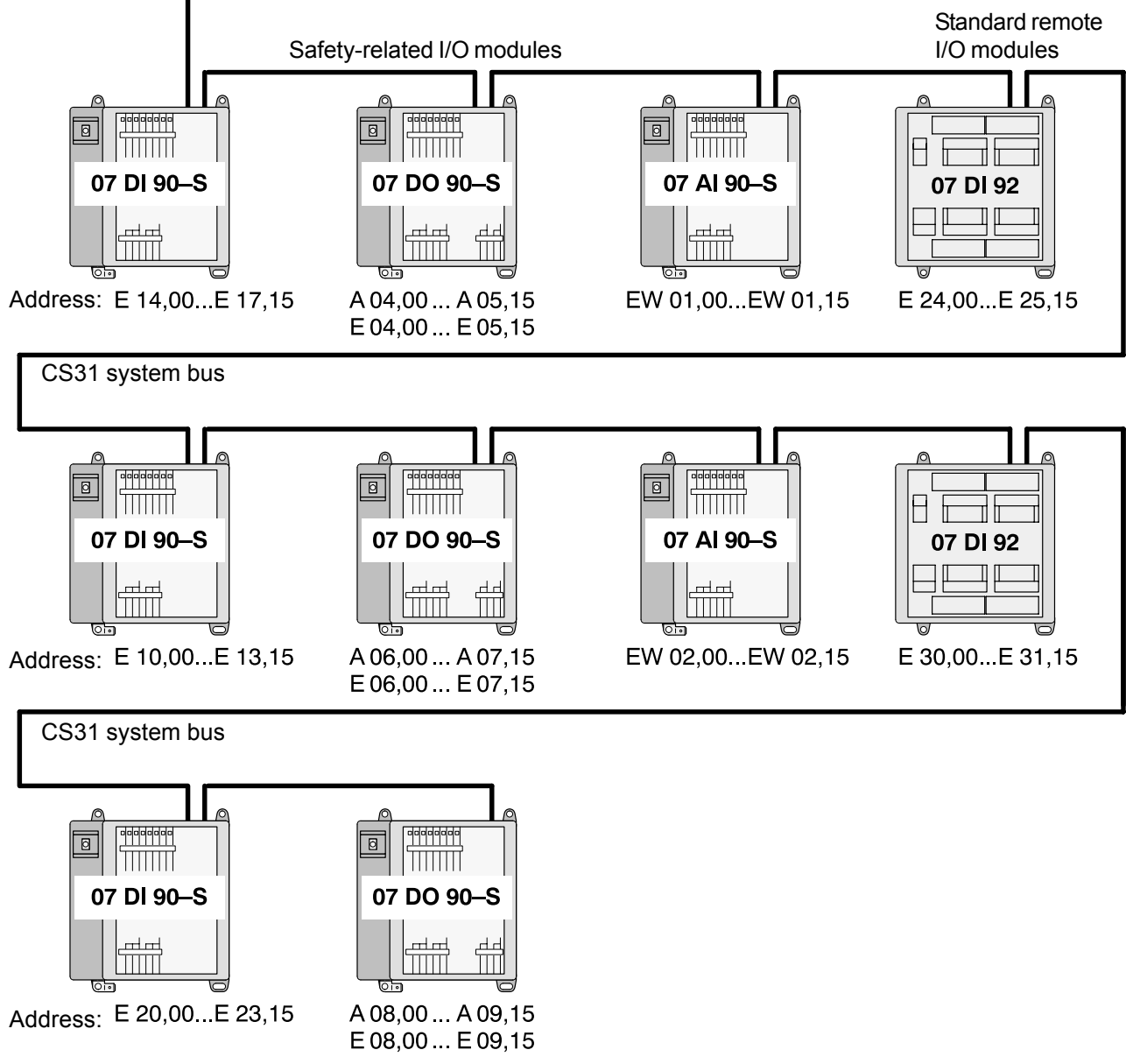
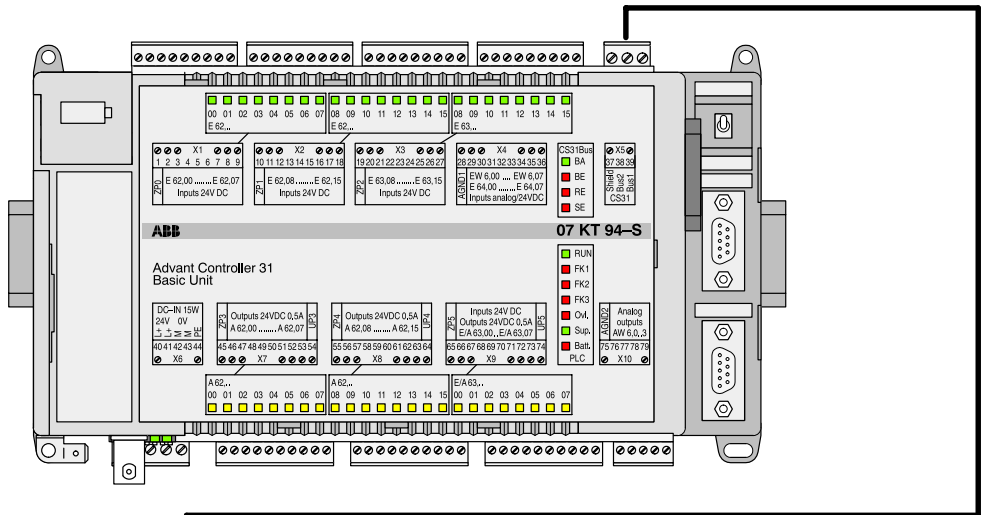
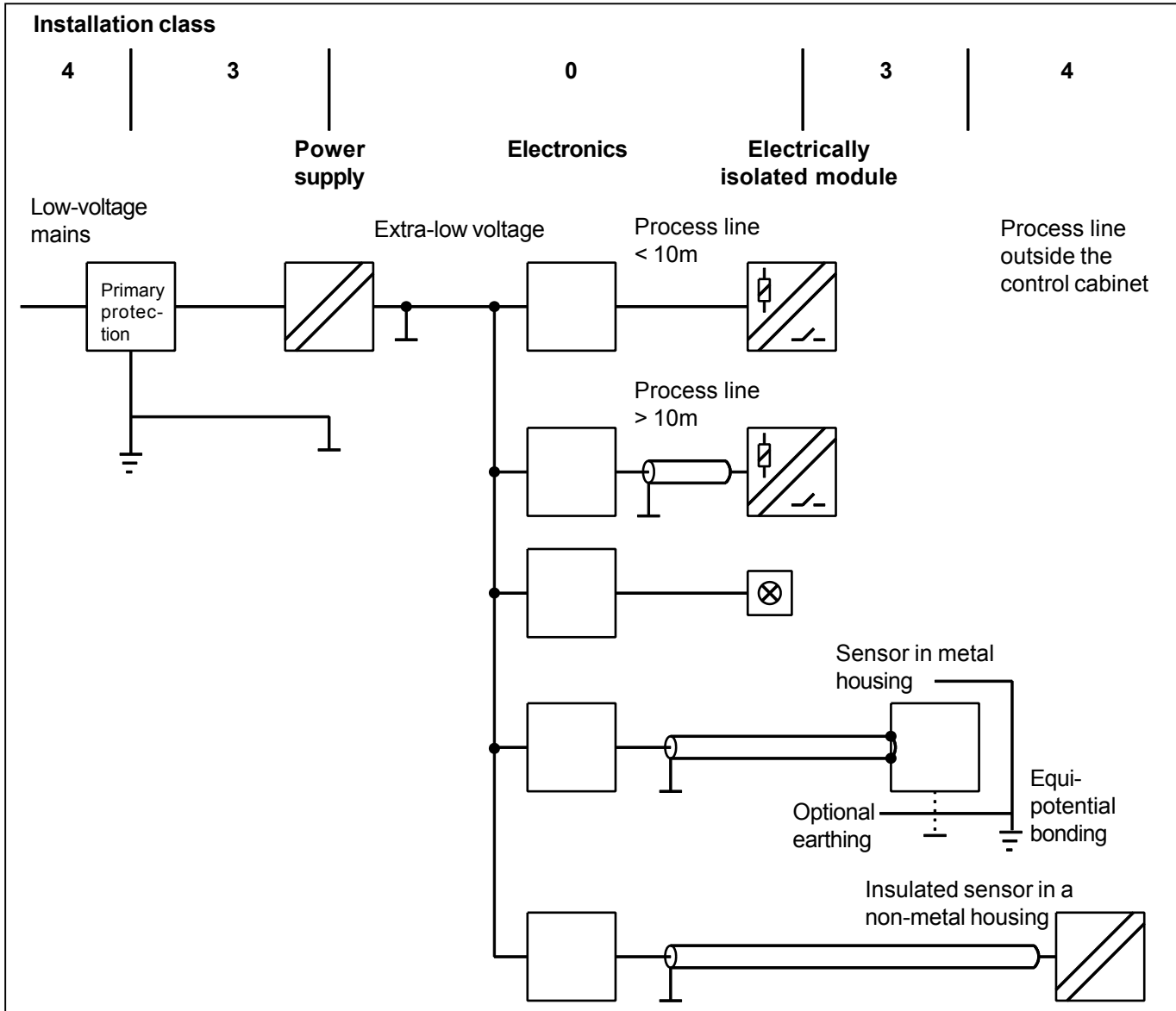

Figure 3-3: Hardware configuration for the previous example

3.4 Lightning protection / wiring concept

3.4.1 Lightning protection



3.4.1.1 Connecting the low-voltage mains

- Earthing the system (e.g. crane construction)
- Connection of the low-voltage mains to the metal construction via valve-type arrester (primary protection) in the first control cabinet or in the building-site distribution board, if the supply conductors < 10 m and a potential equalizer exists between construction and PE (protective earth)
- Connection of PE to the metal construction in each control cabinet

In case of road traffic signal systems, the regulations of DIN VDE 0832 chapter 5 (Protection against dangerous shock currents) and chapter 6 (Other protection measures) have to be met.

3.4.1.2 Connecting the electronics

- The 0 V of the 24 V DC supply must be earthed at the power supply unit.
- Signal and bus lines led out of the control cabinet must be shielded.
- Metallic sensor housings must generally be connected to the shields.

If the equipotential bonding between sensor housing and control cabinet is sufficient,

- the shield has to be connected in each control cabinet directly to control cabinet earth
- the shield on the sensor side has to be connected directly with its housing

If no direct lightning strike is possible the sensor housings can alternatively be insulated.

- For connections to potential-free devices in the control cabinet (e.g. contactors), no measures concerning shielding are necessary.

3.4.2 Wiring concept without filter

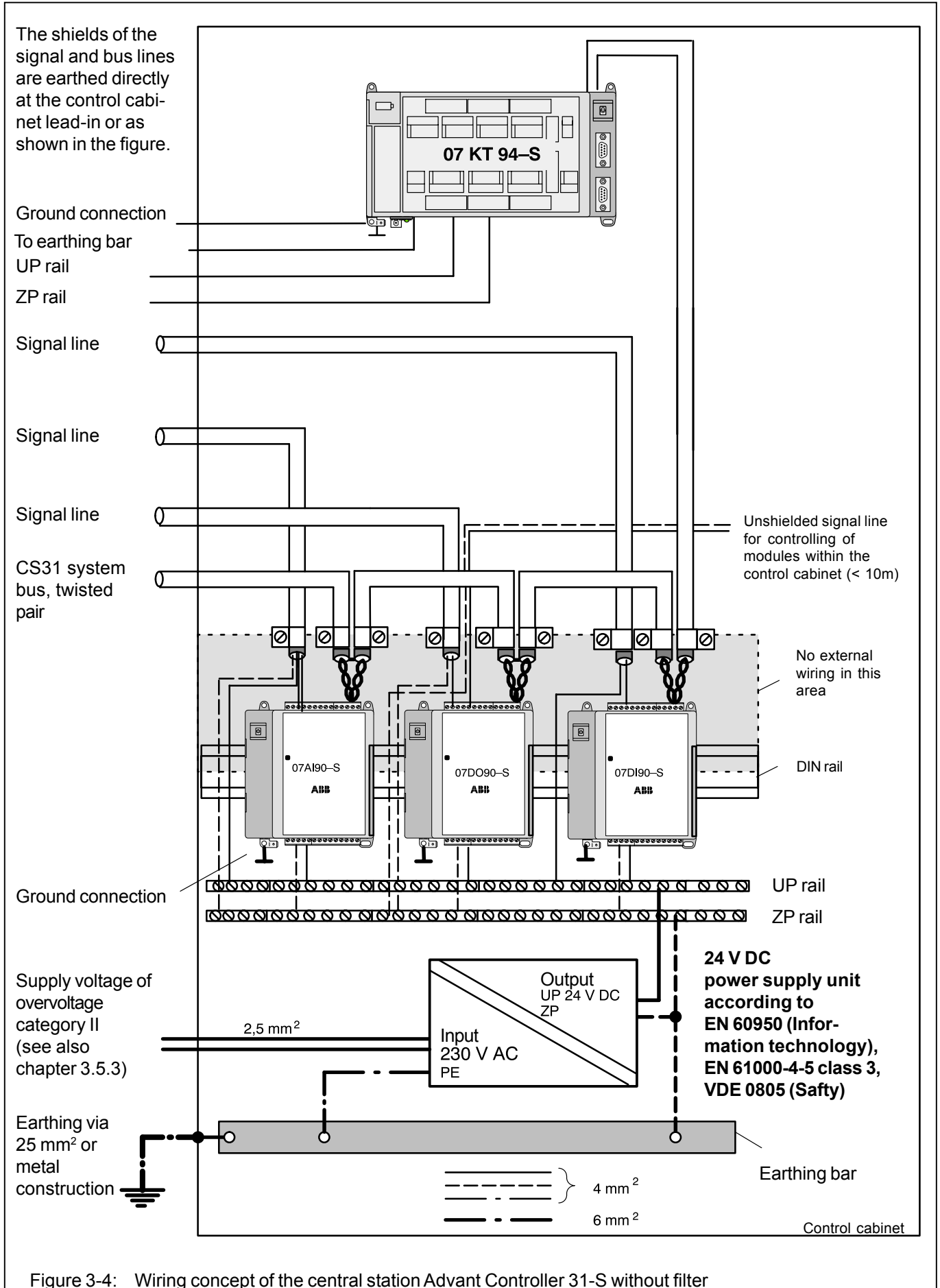

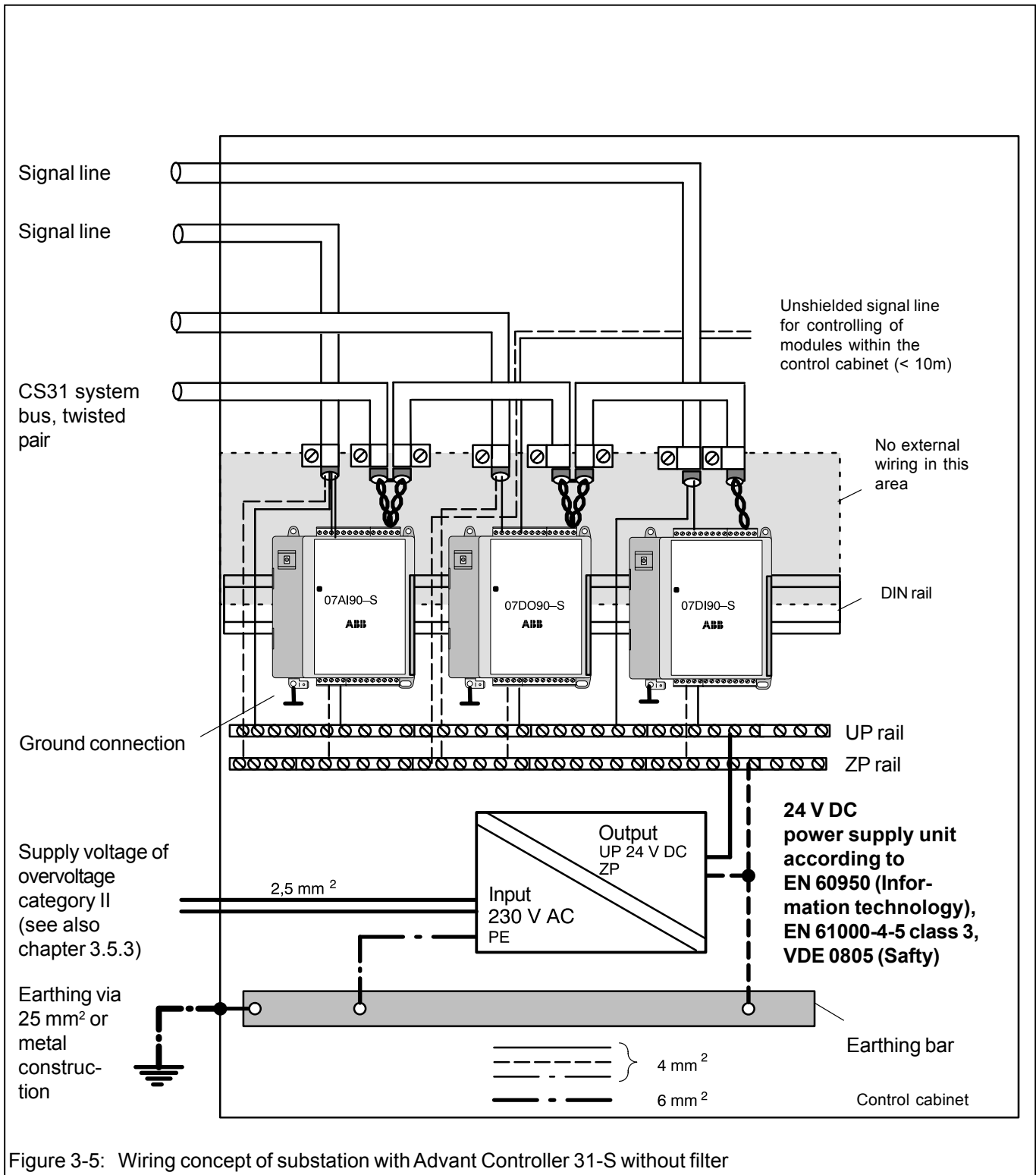

Figure 3-5: Wiring concept of substation with Advant Controller 31-S without filter

3.4.2 Wiring concept with requirements according to EN 298 Firing equipments for gas burner and gas units with and without blower

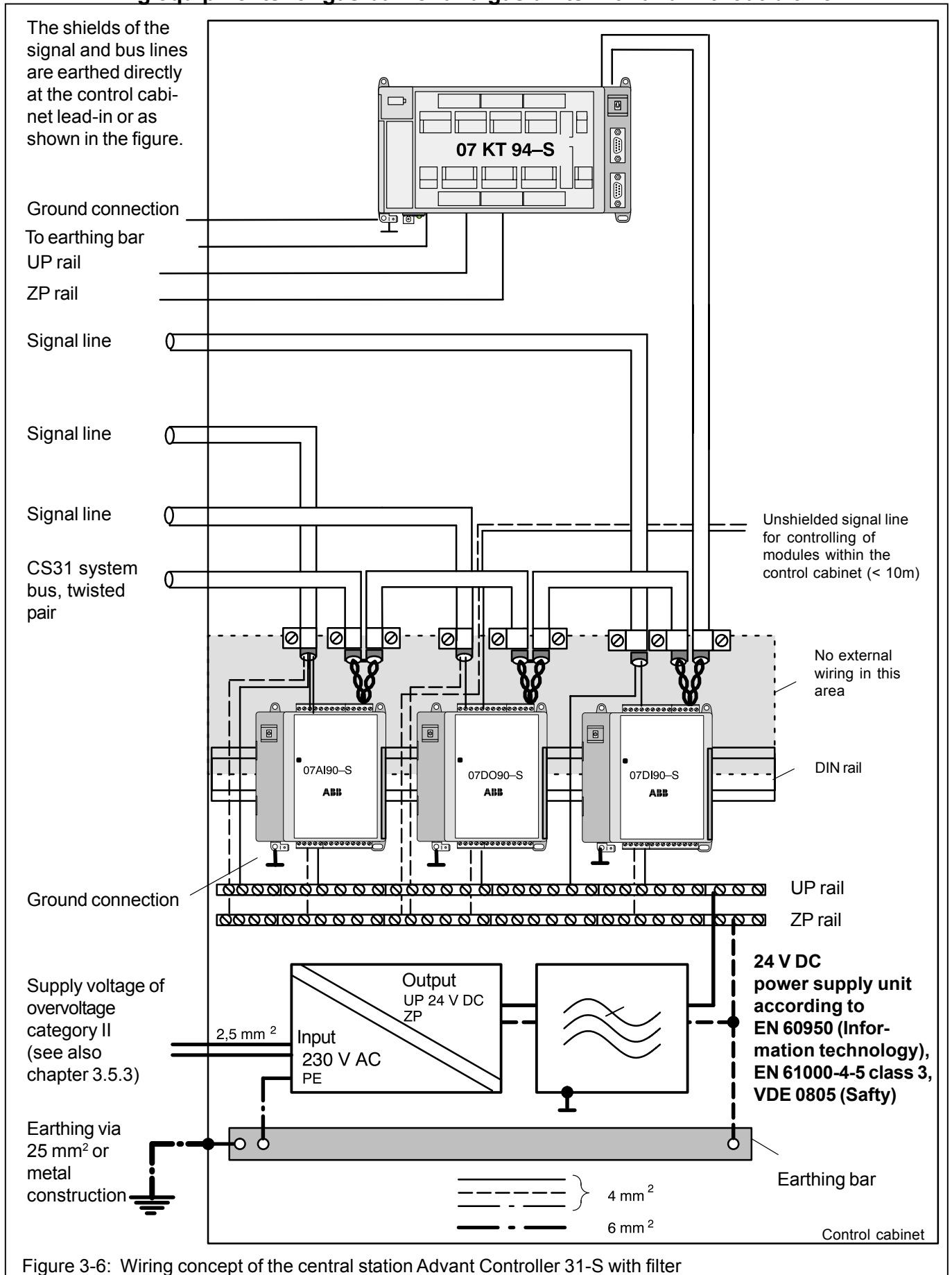

Figure 3-6: Wiring concept of the central station Advant Controller 31-S with filter

Filter: Messrs. Schaffner, Typ FN612-1/06 or similar general-purpose filter FN6xxx made by Messrs. Schaffner (www.schaffner.de)

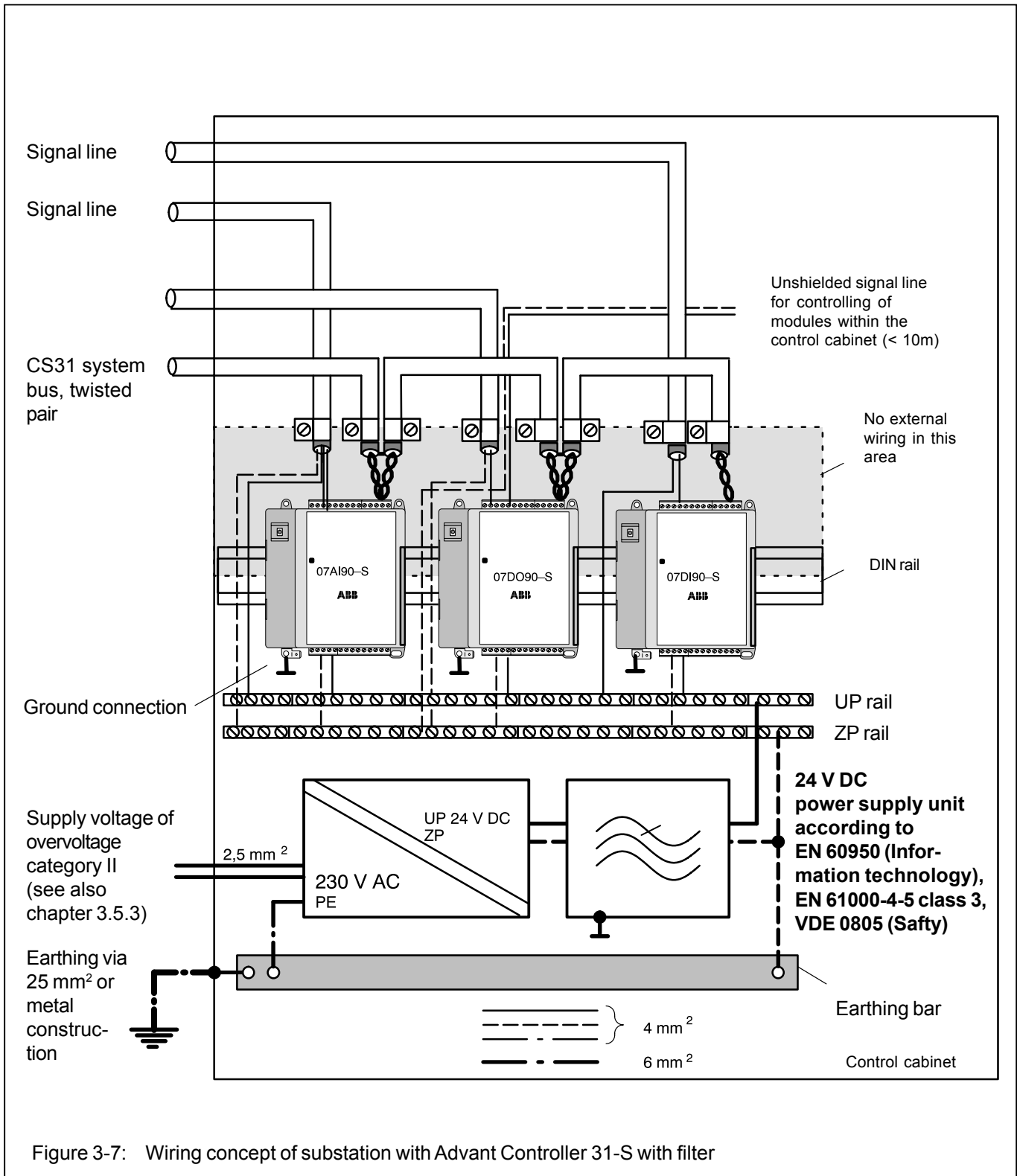
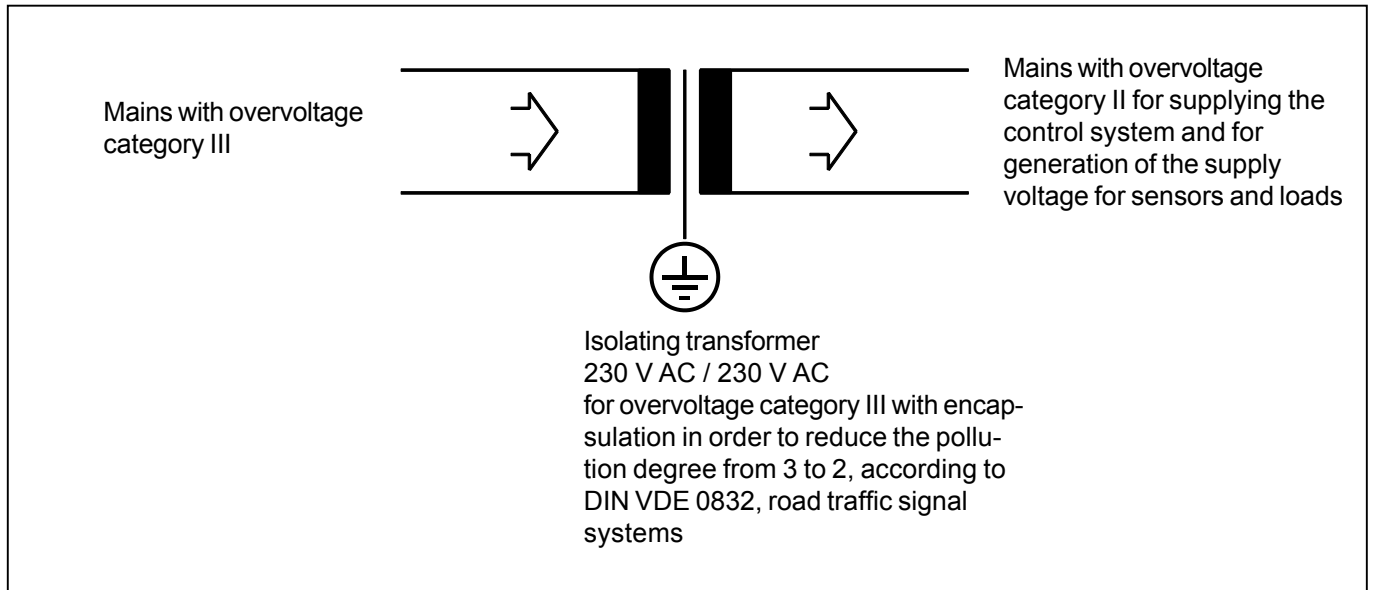

Figure 3-7: Wiring concept of substation with Advant Controller 31-S with filter

Filter: Messrs. Schaffner, Typ FN612-1/06 or similar general-purpose filter FN6xxx made by Messrs. Schaffner (www.schaffner.de)

3.4.4 Using the Advant Controller 31-S in networks of overvoltage category III (e.g. in road traffic signal systems according to DIN VDE 0832)



3.5 Behaviour on power ON

Due to the mutual monitoring of the I/O modules with the central unit, it is necessary to switch on the I/O modules before or simultaneously with the central unit of the ABB AC31. Otherwise an error message will be generated (SERR output) causing the control to be switched off.

If another behaviour is desired this can be planned accordingly after coordination with the local inspectors. For instance for the service operation or for the commissioning, another behaviour can be planned.

3.6 Behaviour in case of errors on the safety-related I/O modules

Errors on safety-related I/O modules are detected by the corresponding S-CEs (S_LEB, S_LAB, S_LEA). The error reaction is planned in cooperation with the local inspectors or in accordance with the TÜV specifications.

The above mentioned S-CEs allow for the detection of both external and internal errors. If for instance a module 07 DO 90-S fails, the read CE generates the single-channel error message as well as the sum error message as no valid status telegram from the related output module had been received within the monitoring time.

If a single-channel error message is generated, it depends on the specifications of the TÜV or the local inspector how the system has to react to this external error of an I/O module.

The further measures can be planned in accordance with the specifications, e.g. abort of the total system or entering another operating mode with restricted function scope (see also programming, chapter 4).

4 Binary input module 07 DI 90-S, safety-related, 24 V DC, 8 inputs, electrically isolated from the CS31 system bus

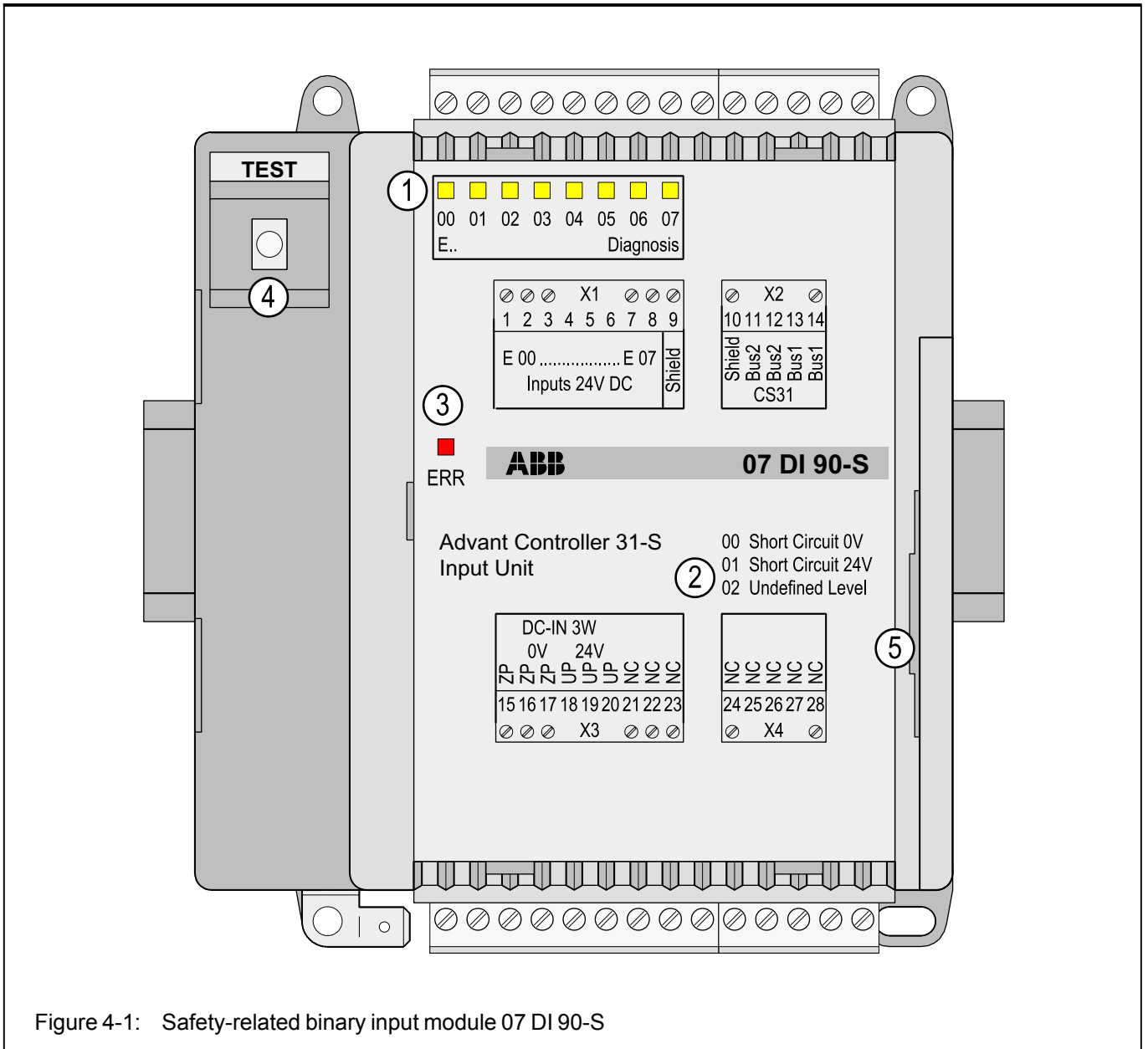

Figure 4-1: Safety-related binary input module 07 DI 90-S

Contents

Intended purpose	4-1
Indicators and operating elements on the front panel	4-2
Functional description	4-2
Principle of function	4-3
Electrical connection	4-3
Addressing (setting the module address)	4-6
Auxiliary and diagnosis functions	4-7
Start-up behaviour	4-7
Diagnosis at the module	4-7
Technical data	4-8
Installation and dimensions	4-9

Intended purpose

The module 07 DI 90-S is a binary input module with 8 input channels for 24 V DC safety-related sensors.

The module is part of the safety-related PLC (Advant Controller 31-S). It is used in safety-relevant automation systems to be classified under requirement classes 1...4 according to DIN V 19250.

It is used as a remote module and linked to the central unit 07 KT 94-S via the CS31 system bus.

The CS31 system bus interface is electrically isolated from the other circuitry of the module.

The input signals of the module 07 DI 90-S are read in by the AC31 central unit using special safety-related connection elements (CEs).

- ⑤ DIL switch for address setting below the cover

Indicators and operating elements on the front panel

- ① 8 yellow LEDs for indication of the signal state at the inputs or for error and diagnosis indication
- ② List of the diagnosis information referred to the LEDs if these are used for diagnosis indication
- ③ Red LED for error indication
- ④ Test button

Functional description

As shown in the following Figure 4-2, the signal processing is mainly realized by means of dual-channel technique. In this way, the following tasks can be handled:

- Signal states are safely detected, wire cuts and short-circuits of signals are safely differentiated. Open inputs or wire cuts are interpreted as a short-circuit against ZP.
- Single faults are detected and lead to a safe shut-down.

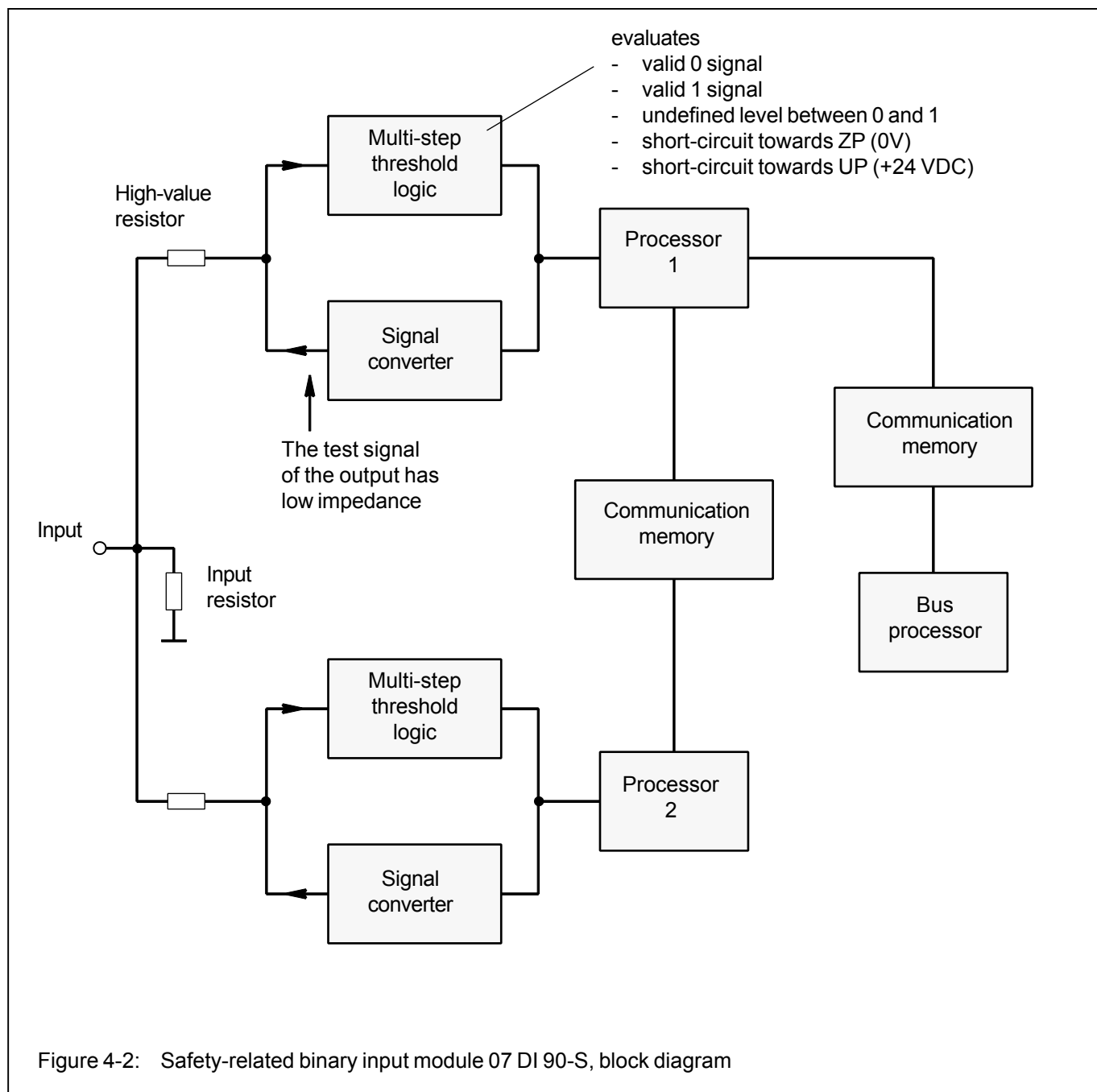

Principle of function

The input current flowing through the input resistor generates a voltage drop which is led to two identically configured evaluation channels via high-value resistors. The high-resistivity of the resistors guarantees a non-interacting between both channels.

Both channels mutually supervise each other, by

- their processors comparing the evaluated input signals to each other;
- their processors generating multi-step binary signals in check cycles via signal converters and by comparing the values derived from this by the threshold switch to the expected value;
- their processors mutually checking each other for their function ability.

The dual-channel principle terminates at the bus processor with a specially safety-related telegram.

System bus interface

The CS31 system bus interface, which is electrically isolated, provides for the data exchange via the bus.

Process supply voltage UP

There is no electrical isolation between the process supply voltage and the binary inputs.

It must be observed by any means that the binary safety-related sensors are supplied by the same UP rail as the module itself. Only in this way, the 5 possible states of the module input signals can be correctly differentiated:

- valid 0 signal
- valid 1 signal
- undefined level between 0 and 1
- short-circuit towards ZP (0V) and
- short-circuit towards UP (+24 V).

Electrical connection

For the planning of the AC31-S, the safety manual for the AC31-S (this file) must be observed. Here, both the architecture of the PLC program and the construction of the hardware components and their wiring are described in detail.

The module is either snapped-on to a DIN rail or directly screwed on the control cabinet's rear wall. The electrical connection is realized via pluggable terminal blocks. All terminal blocks must be installed even those which are not used.

Figure 4-4 on page 4-5 shows the terminal assignment of the module with a wiring example for a safety-related sensor.

In this example it is assumed that the resistors for the open-circuit monitoring are integrated into the safety-related sensors. However, this is not the case for all of them.

If safety-related sensors without integrated resistors are to be connected to the module 07 DI 90-S, there are two options:

- The wiring of the cables is completed according to the valid VDE regulations and for instance the fault exclusion according to VDE 0116 chapter 8.7.4.1 is used, which means that the short-circuiting of a conductor can be excluded as possible error source. Furthermore, if the planning is made according to the closed-circuit principle, the module detects any wire cut. In this case, the resistors may be mounted directly to the terminals of the module 07 DI 90-S.
- However, a higher safety level is achieved if the resistors are directly connected to the terminals of the safety-related sensor as this guarantees a complete cable monitoring.

The resistors used for the safety-related sensors must come up to the following requirements:

- Use of metal-film resistors in order to exclude a self-short-circuit of a resistor
- Resistor specifications:
680 Ω , 1 %, 0,33 W at 70 °C, TK 50 ppm/K and
5,6 k Ω , 1 %, 0,33 W at 70 °C, TK 50 ppm/K
or better. See also Figure 4-4.

Caution: Unused signal inputs have to be put to UP (+24 V) using two resistors of 680 Ω and 5,6 k Ω . Open inputs cause an external error display at the module.

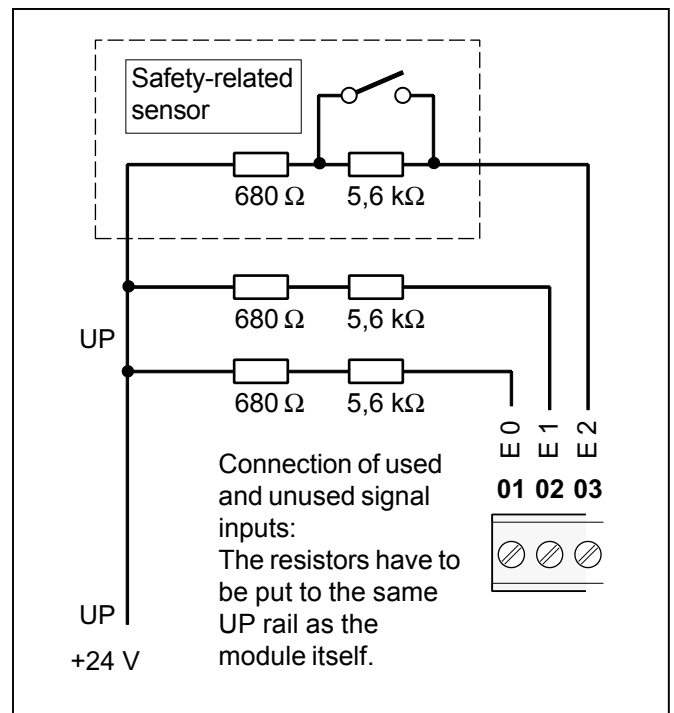

Addressing (setting the module address)

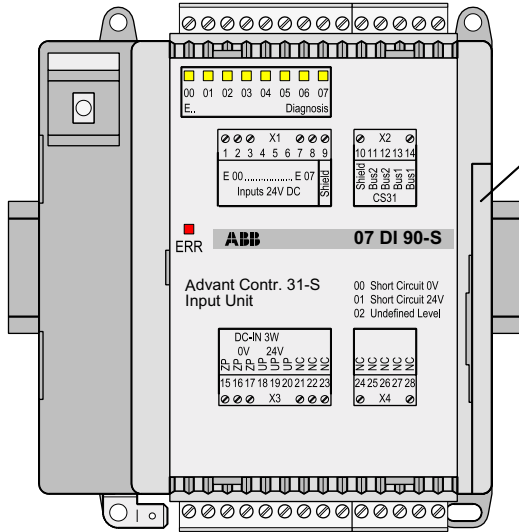

Setting the module address (0...31) is done using a DIL switch. The switch is accessible after removing the lateral cover. Pull the cover towards the front while tilting it lightly to the right. The switch is provided with a lid.

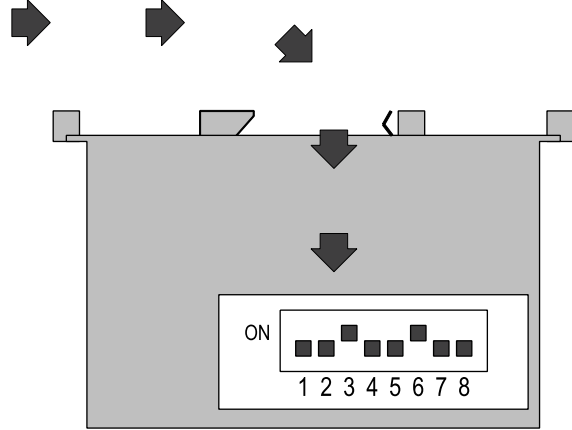

Meaning of the 8 switches:

- Switch 1: must always be set to OFF
- Switch 2: must always be set to OFF
- Switch 3: Module address bit 4, significance 16
- Switch 4: Module address bit 3, significance 8
- Switch 5: Module address bit 2, significance 4
- Switch 6: Module address bit 1, significance 2
- Switch 7: Module address bit 0, significance 1
- Switch 8: must always be set to OFF

The sum of the significance values of the switches in ON position is the set module address, e.g.: switch 3 = ON, significance = 16 and switch 6 = ON, significance = 2 results in module address 18.

Examples: Module address 0
E 00,00 *



Module address 2
E 02,00 *



Module address 6
E 06,00 *

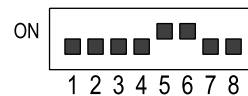

* Address entry at connection element S_LSB

Figure 4-5: 07 DI 90-S, setting of module address at the DIL switch (see also chapter 3.3 "Configuration data for the I/O modules")

Auxiliary and diagnosis functions

Start-up behaviour

After switching the power supply (UP) on, the LED 'ERR' will light up for approx. 10 sec. during the switch-on self-test of the module.

After that, the LED 'ERR' flashes until the module has been adopted in the CS31 bus cycle.

After the 'ERR' signal has gone out, this shows the correct self-test as well as the end of the initialization and adoption in the CS31 system bus.

If, however, the LED 'ERR' is lighting permanently (>15 sec) after switching on the power supply, an internal error has been detected.

The LEDs for channel indication remain off until the initialization is completed. After that, they show the state of the corresponding input channel.

Further diagnosis information are included in the Advant Controller 31 System Description (AC31 error flags).

Fuses

The module has an integrated solder-in-type micro-fuse for the supply voltage UP. If this fuse blows, the following error indication takes place:

- The module has no function any more.
- All LEDs are off.

The module has to be replaced.

Diagnosis at the module

The module distinguishes between 2 different error types:

- External errors:
 - Short-circuit of a sensor line towards 0 V or cut of a sensor line
 - Short-circuit of a sensor line towards UP
 - Input signal has exceeded the permissible input level ranges
- Internal errors:
 - all other errors

Reaction to external errors:

- The LED 'ERR' starts flashing.
- The channel state of the faulty channel is frozen.
- The error can be requested via the test button of the module.
- The error-free input channels continue the signal processing.
- The channel is marked as faulty via the CE 'S_LEB' for the AC31 central unit.
- After error recovery, the error can be acknowledged with the test button.

Reaction to internal errors:

- The LED 'ERR' and all input channel LEDs are lighting permanently.
- The module stops the processing of all input signals.
- The entire module is marked as faulty via the CE 'S_LEB' for the AC31 central unit.
- After error recovery, the error can be acknowledged by switching the power OFF and then ON again.
- Refer to chapter "Diagnosis and troubleshooting" in volume 7 for further diagnosis information.

Diagnosis of external errors:

- By pressing the "TEST" pushbutton, the channels are selected subsequently. After pressing this key, the LED of the selected channel starts flashing. After releasing the pushbutton, the error indication of the selected channel (e.g. LED 01 for short-circuit towards 0 V) is displayed in the channel LEDs for approx. 2 seconds. After that, the module switches back to the status indication of the input channels. Now, the next channel can be selected.
- After selecting and querying channel 7, an LED test will be carried out after pressing the test pushbutton (all channel LEDs light up). After releasing the pushbutton, the set module address is displayed for approx. 2 seconds.
- The acknowledgement of external errors is made by pressing the test pushbutton somewhat longer (approx. 5 seconds).

Technical data

Process and supply voltage UP (power supply according to VDE 0551 is necessary)	
rated voltage	24 V DC \pm 5 % ripple
upper limit value	24 V DC + 20 % = 28,8 V (\pm 5 % ripple)
lower limit value	24 V DC - 15 % = 20,4 V (\pm 5 % ripple)
The supply voltage must rise to at least 19 V within 0 to 40 msec after being switched on.	
Buffered voltage interruption time	> 10 ms
Reference potential ZP	0 V for process voltage UP
Protection against reversed polarity (UP \leftrightarrow 0V)	yes
Number of inputs per module	8 (for safety-related sensors)
Signal levels of the inputs (nominal values)	
short-circuit towards ZP	0%... 15% of UP (0 V... 3,6 V for UP = 24 V)
0 signal	15%... 35% of UP (+3,6 V... 8,4 V for UP = 24 V)
undefined level	35%... 65% of UP (+8,4 V... 15,6 V for UP = 24 V)
1 signal	65%... 85% of UP (+15,6 V... 20,4 V for UP = 24 V)
short-circuit towards UP	85%... 100% of UP (+20,4 V... 24,0 V for UP = 24 V)
Input resistance	approx. 2,2 k Ω
Input current at 24 V DC	approx. 10 mA
Input signal delay (edges 0 -> 1 and 1 -> 0)	typ. 5 ms, monitoring to 20 ms
Input frequency	max. 20 Hz (higher input frequency leads to an external or an internal error)
Input signal transition time (edges 0 -> 1 and 1 -> 0)	0 ms...5 ms
Cable lengths with cables laid in parallel	
shielded	max. 1000 m
unshielded	max. 600 m
Conductor cross section of process terminals	max. 1 x 2,5 mm ²
tightening torque	max. 0.5 Nm
Electrical isolation	from the CS31 system bus
Rated insulation voltage, process terminals from CS31 system bus:	
acc. to VDE 0160, rated direct voltage	0...50 V
test voltage for reinforced insulation	800 V DC
Current consumption (UP)	110 mA
Total power dissipation	max. 3 W
Address setting	see page 4-5
Indication of input signals	one yellow LED per channel
Error indication	one red LED (ERR)
Safety-related sensor (snap-action contact element)	
resistance, if contact is open	5,6 k Ω + 680 Ω (\pm 1 %)
contact is closed	680 Ω (\pm 1 %)
Specifications for the resistors of the sensor	680 Ω , 1 %, 0,33 W at 70 °C, TK 50 ppm/K and 5,6 k Ω , 1 %, 0,33 W at 70 °C, TK 50 ppm/K or better
Safety-related CE (S-CE) in the PLC software	S_LEB: Read binary S-input module

Module-specific CS31 bus transmission time	590 □s
Dimensions (width x height x depth) in mm	120 x 140 x 85 mm (see below)
Weight	400 g
Order number	07 DI 90-S
	GJR5 2509 00 R202

Installation and dimensions

Fixing the module on a DIN rail

The easiest and fastest way to install the module is to snap it on to a DIN rail (acc. to DIN EN 50022-35, 15 mm deep). Neither for the assembly nor for the disassembly, any tools are required. The DIN rail is centered between upper and lower edge of the module.

Fixing the module by screwing

Using 4 M4 screws, the module can be fastened on an assembly surface (e.g. rear wall of the control cabinet). The following drawing shows the position of the fixing holes as well as all important assembly dimensions.

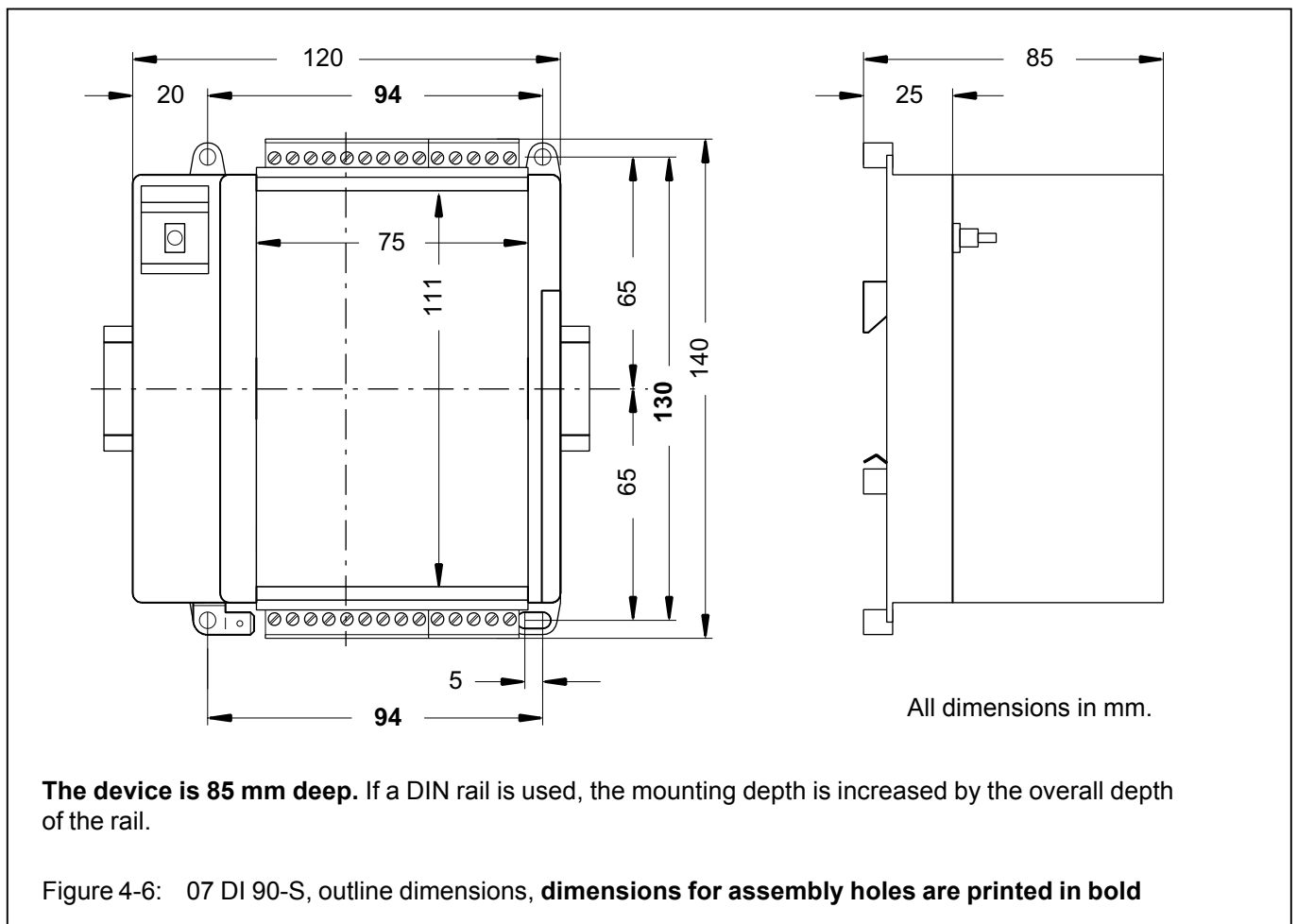

Mounting hints

Mounting position

Vertical, terminals above and below

Cooling

The natural convection cooling must not be hindered by cable ducts or other material mounted in the control cabinet.

5 Binary output module 07 DO 90-S, safety-related, 24 V DC, 8 outputs, electrically isolated

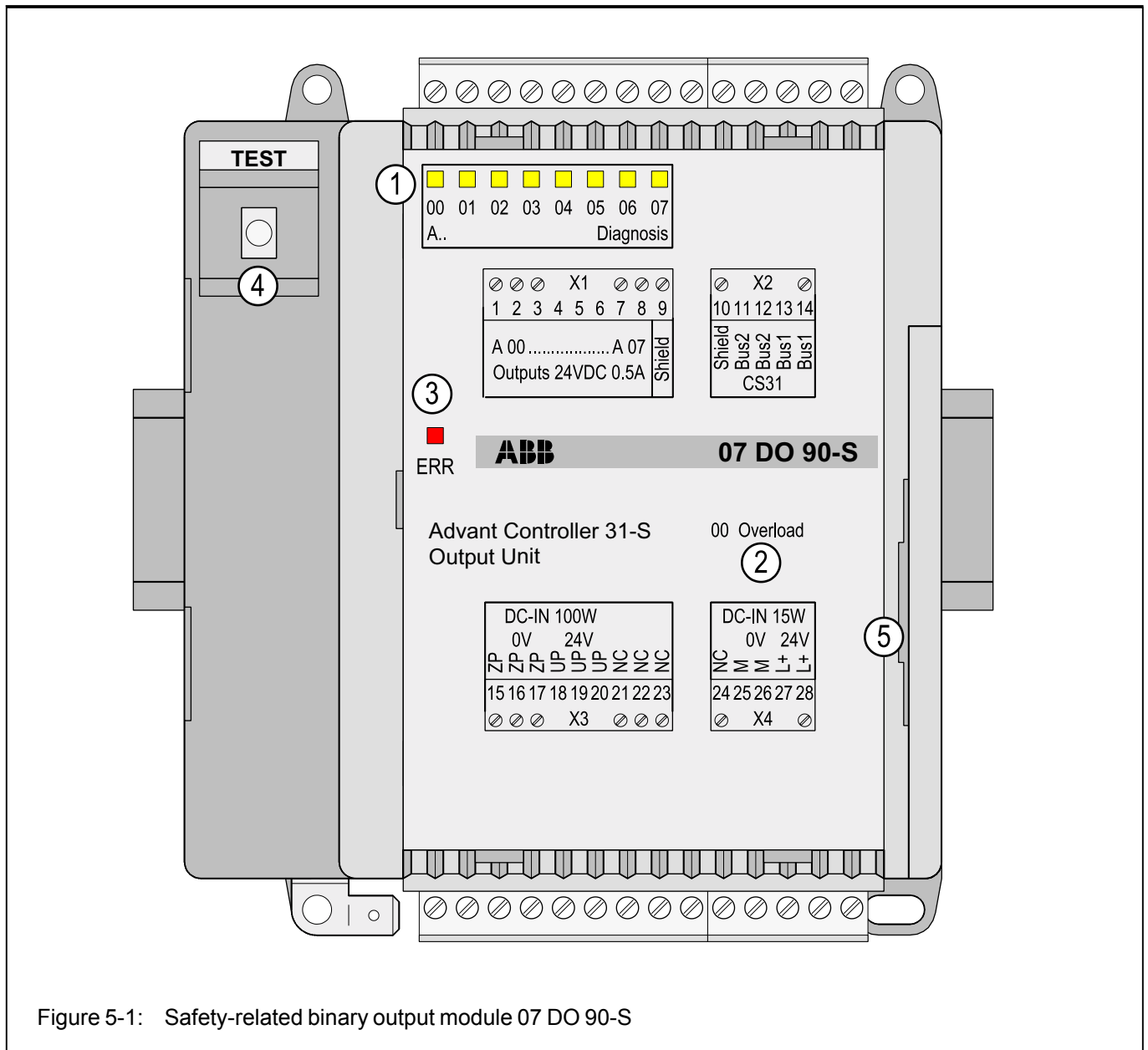

Figure 5-1: Safety-related binary output module 07 DO 90-S

Contents

Intended purpose	5-1
Indicators and operating elements on the front panel	5-2
Functional description	5-2
Electrical connection	5-3
Addressing (setting the module address)	5-5
Auxiliary and diagnosis functions	5-6
Start-up behaviour	5-6
Diagnosis at the module	5-6
Technical data	5-7
Installation and dimensions	5-8

Intended purpose

The module 07 DO 90-S is a binary output module with 8 electrically isolated output channels for 24 V DC.

The module is part of the safety-related PLC (Advant Controller 31-S). It is used in safety-relevant automation systems to be classified under requirement classes 1...4 according to DIN V 19250.

It is used as a remote module and linked to the central unit 07 KT 94-S via the CS31 system bus.

The CS31 system bus interface is electrically isolated from the other circuitry of the module.

The outputs of the module 07 DO 90-S are set by the AC31 central unit via special safety-related connection elements (CEs).

Indicators and operating elements on the front panel

- ① 8 yellow LEDs for indication of the signal state at the outputs or for error and diagnosis indication
- ② List of the diagnosis information referred to the LEDs if these are used for diagnosis indication
- ③ Red LED for error indication
- ④ Test button
- ⑤ DIL switch for address setting under the cover

Functional description

see block diagram on the next page

Principle of the safety-related outputs

The safety-related output module is configured in a way that even in case of errors the safe states at the outputs are granted. The safe state is defined as the off-state of the outputs.

The output channels are organized in two groups with 4 outputs each. Each group disposes of an additional power transistor as second independent switch-off path besides the 4 short-circuit-proof output drivers.

The signal state of each output channel is read back via an input channel. The connection element (CE) S_LAB compares the sent signal with the signal which is read back at the input channel. If the signals are not equal, a message is generated.

Partially two-channel configuration

The module is largely configured in dual-channel technique. Two processors control and monitor the output drivers. An output driver is only activated if it is addressed by both processors simultaneously.

External and internal errors of the output module

Overload (or short-circuit towards ZP) is an external error and leads to a safe shut-down of the affected group. All other errors are internal errors and cause the shut-down of all outputs (RESET).

The correct function of the output drivers and the power transistors responsible for the group shut-down is checked cyclically as to their switch on/off capacity during the operation. For this purpose, the switching states are temporarily changed (duration < 1 msec). Any relays or other loads controlled by the output drivers must be designed in a way that they do not react to these short pulses.

The changing of the output signal states are detected and transferred to both processors for checking. By checking just one output at the same time, a possible cross-talk to neighboring channels can also be detected.

Power supply for the output circuitry

The output drivers are supplied by ZP and UP (24 V DC). This supply voltage is electrically isolated from the CS31 system bus and also from the 24 V DC supply voltage (M, L+) for controlling and monitoring the outputs.

Power supply for the CS31 bus coupling

The supply voltage for the bus coupling is provided internally using an electrically isolated DC/DC converter supplied from 24 V DC (L+, M).

Electrical isolation

All signals, which are to be led via electrically isolated barriers, are transmitted with optocouplers.

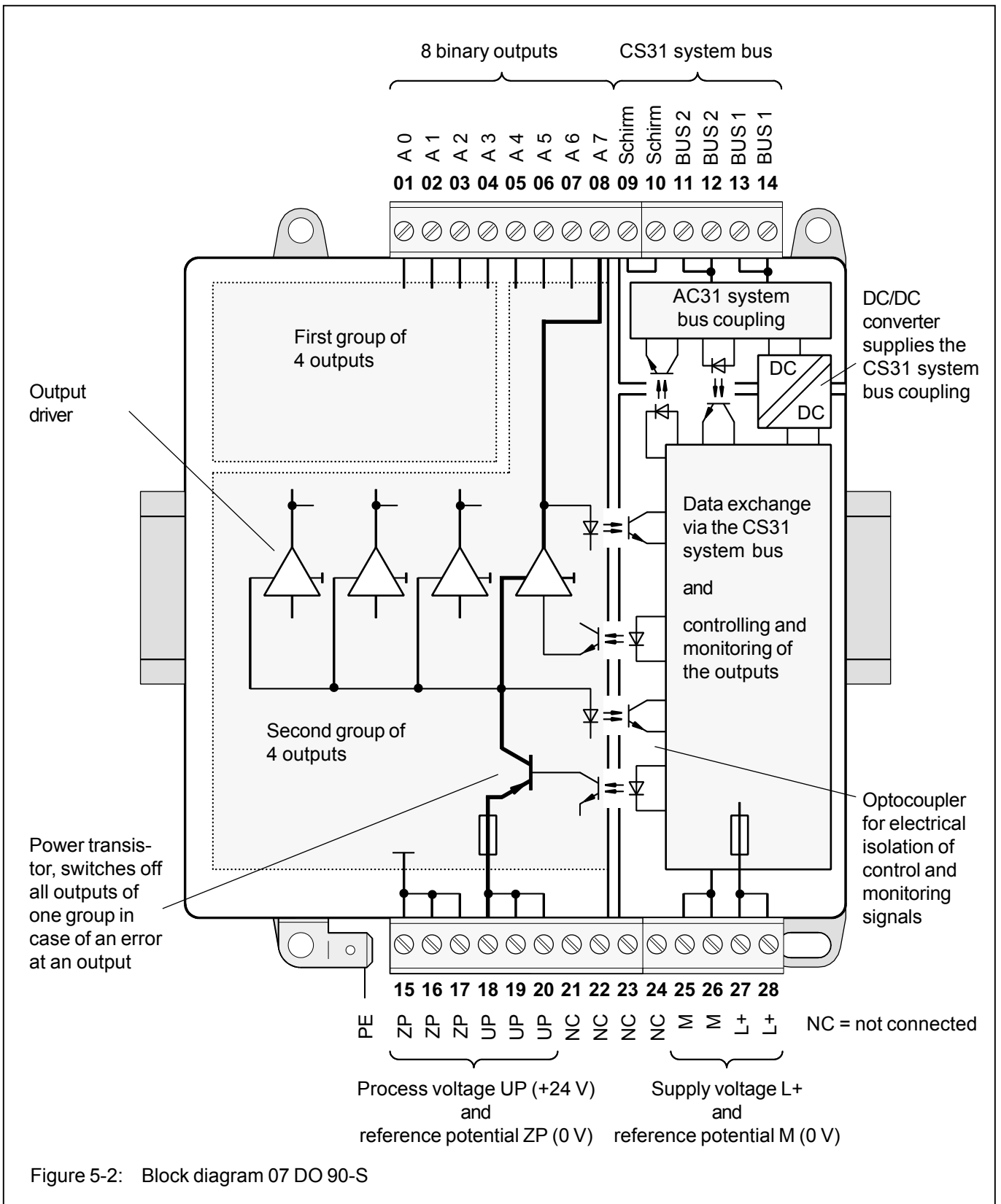

Figure 5-2: Block diagram 07 DO 90-S

Electrical connection

For the planning of the AC31-S, the safety manual for the AC31-S (this file) must be observed. Here, both the architecture of the PLC program and the construction of the hardware components and their wiring are described in detail.

The module is either snapped-on to a DIN rail or directly screwed on the control cabinet's rear wall. The electrical connection is established via pluggable terminal blocks. All terminal blocks must be plugged even those which are not used.

The figure on the next page shows the terminal assignment of the module.

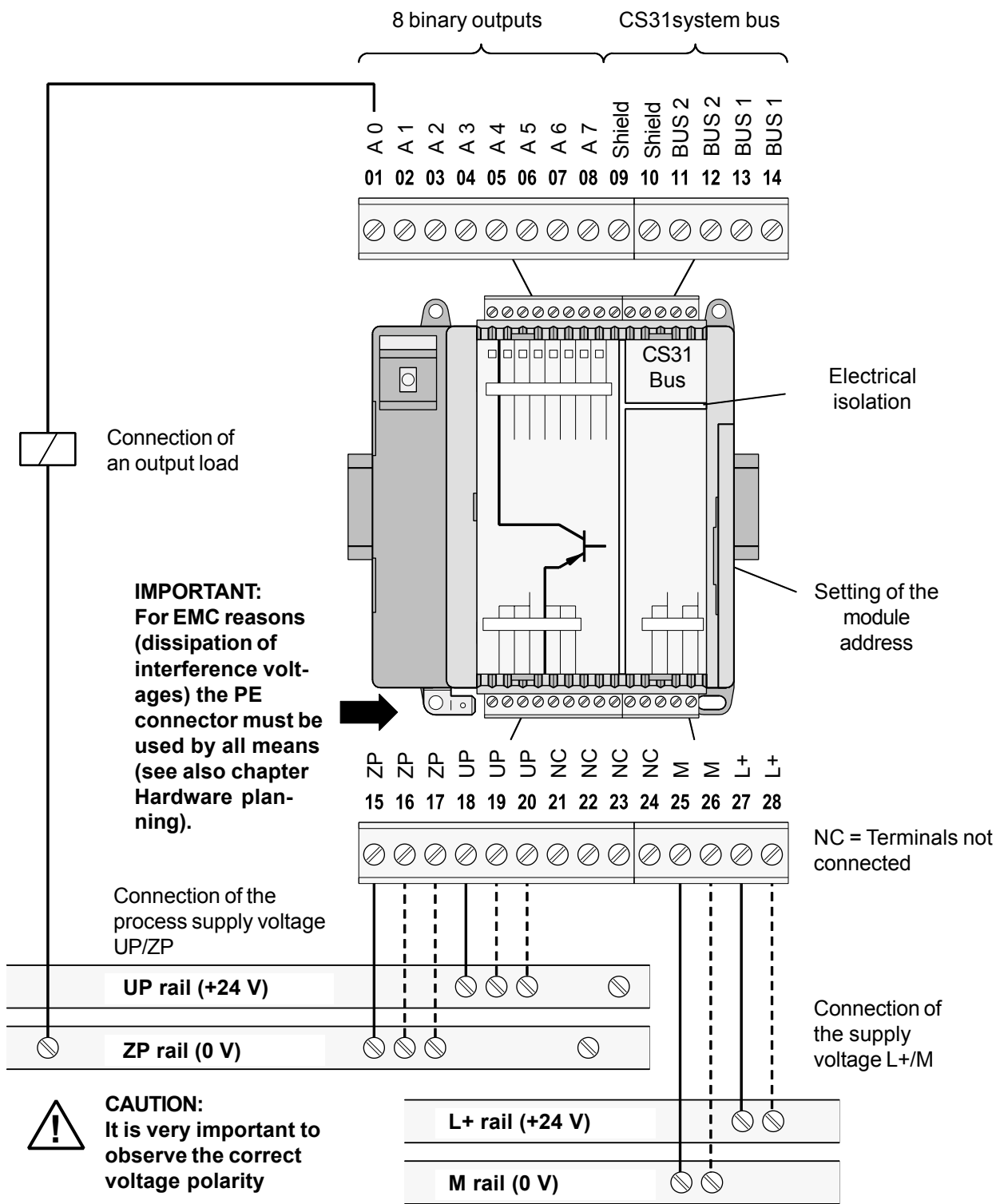

The terminals ZP and UP are intended for the supply of the module's outputs. The terminals M and L+ (electrically isolated from ZP and UP) supply the module's internal circuitry. If ZP and UP or M and L+ are looped through from module to module, the following points must be observed:

- When unplugging the terminal block, the power supply to the modules connected in series is switched off.
- At the terminals (and the plug-in connections) a total current of 4 A must not be exceeded.

Figure 5-3: 07 DO 90-S, terminal assignment and connection example for an output

Addressing (setting the module address)

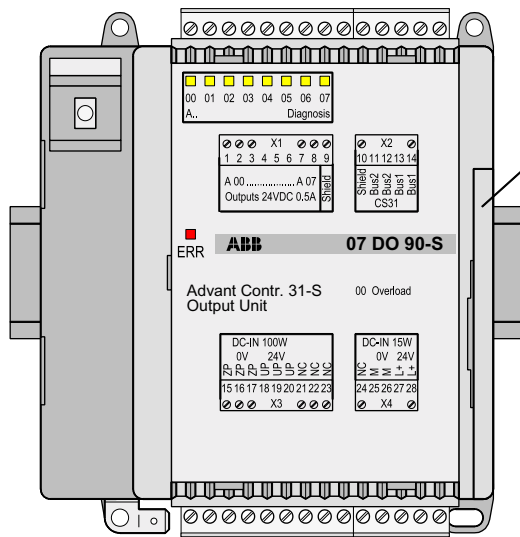

Setting the module address (0...31) is done using a DIL switch. The switch is accessible after removing the lateral cover. Pull the cover towards the front while tilting it lightly to the right. The switch is provided with a lid.

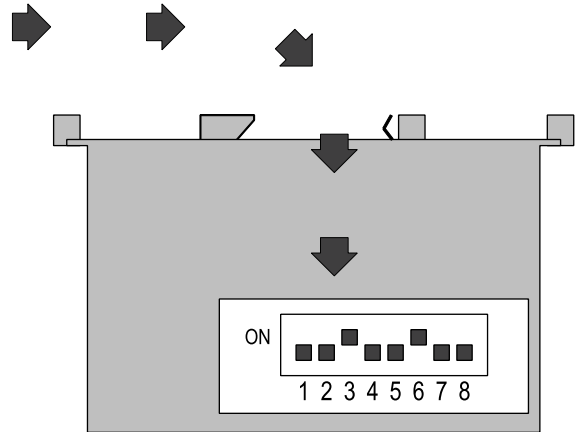

Meaning of the 8 switches:

- Switch 1: must always be set to OFF
- Switch 2: must always be set to OFF
- Switch 3: Module address bit 4, significance 16
- Switch 4: Module address bit 3, significance 8
- Switch 5: Module address bit 2, significance 4
- Switch 6: Module address bit 1, significance 2
- Switch 7: Module address bit 0, significance 1
- Switch 8: must always be set to OFF

The sum of the significance values of the switches in ON position is the set module address, e.g.: switch 3 = ON, significance = 16 and switch 6 = ON, significance = 2 results in module address 18.

Examples:

Module address 0
A 00,00 *
E 00,00



Module address 2
A 02,00 *
E 02,00

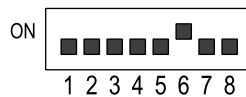

Module address 10
A 10,00 *
E 10,00

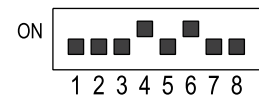

* Address entry at connection element S_LAB, S_SAB

Figure 5-4: 07 DO 90-S, setting of the module address at the DIL switch (see also chapter 3.3 "Configuration data for the I/O modules")

Auxiliary and diagnosis functions

Start-up behaviour

After switching on the power supply (L+), the LED 'ERR' will light up for approx. 10 sec. during the start-up selftest of the module. The process voltage UP must be switched on prior to or simultaneously with the supply voltage L+. Otherwise the start-up selftest of the outputs will cause the module's shut-down.

After that, the LED 'ERR' flashes until the module has been adopted in the CS31 bus cycle.

After the 'ERR' signal has gone out, this shows the correct self-test as well as the end of the initialization and adoption in the CS31 system bus.

If, however, the LED 'ERR' is lighting permanently (>15 sec) after switching on the power supply, an internal error has been detected.

The LEDs for channel indication remain off until the initialization is completed. After that, they show the state of the corresponding output channel (when activated by the AC31 control unit).

Fuses

The module has three integrated solder-in-type micro-fuses (one for the supply voltage UP and one for each output group, see also Figure 5-2).

If the fuse for UP blows, the following error indication takes place:

- The module has no function any more.
- All LEDs are off.

If one of the fuses for the output groups blows, the affected output group indicates an external error.

The module has always to be replaced if a fuse has blown.

Diagnosis at the module

The module distinguishes between internal and external errors.

Reaction to internal errors:

- The LED 'ERR' and all output channel LEDs are lighting permanently.
- The module stops the processing and switches off all outputs safely.
- After error recovery, the error can be acknowledged by switching the supply voltage L+ OFF and then ON again.
- The entire module is marked as faulty via the CE 'S_LEB' for the AC31 central unit.
- Refer to chapter "Diagnosis and troubleshooting" in volume 7 for further diagnosis information.

Reaction to external errors:

- The LED 'ERR' is flashing.
- The power supply of the affected driver group (there are two groups with 4 outputs each) is switched off.
- The error can be requested via the test button of the module.
- After error recovery, the error can be acknowledged by switching the supply voltage L+ OFF and then ON again.

Diagnosis pushbutton:

- By pressing the "TEST" pushbutton, the channels are selected subsequently. After pressing this key, the LED of the selected channel starts flashing. After releasing the pushbutton, the error indication of the selected channel is displayed in the channel LEDs for approx. 2 seconds (no LED is lighting means that no error has occurred). After that, the module switches again to the status indication of the output channels. Now, the next channel can be selected.
- After selecting and querying channel 7, an LED test will be carried out after pressing the test pushbutton (all channel LEDs light up). After releasing the pushbutton, the set module address is displayed for approx. 2 seconds.

Technical data

Process voltage **UP** (supplies the output channels)
and supply voltage **L+** (supplies the module's circuitry)
(power supplies according to VDE551 are necessary)

rated voltage for UP and L+
upper limit value
lower limit value

24 V DC \pm 5 % ripple
24 V DC + 20 % = 28,8 V (\pm 5 % ripple)
24 V DC - 15 % = 20,4 V (\pm 5 % ripple)

The supply voltages must rise to at least 19 V
within 0 to 40 msec after being switched on.

Buffered voltage interruption time,
for L+
for Up

> 10 ms
no interruption allowed (leads to an external error)

Reference potential ZP

0 V for process voltage UP

Reference potential M

0 V for supply voltage L+

Protection against reversed polarity for L+

yes

Number of outputs per module

8

Load current

Maximum value
Leakage current at 0 signal
Lamp load
Total current at all 8 outputs

0.5 A
max. 0.3 mA
max. 5 W
max. 4 A

Switching frequency for inductive loads

max. 0.5 Hz

Limiting of inductive interrupt voltages

yes, with diode

Switching capacitive loads

not allowed (leads to an external error)

Short-circuit protection

yes, electronically

Output signal delay of the module

signal edge 0 -> 1 and 1 -> 0

8 ms, monitoring to 8 ms

Duration of test signal

< 1 ms
During this time the output has the inverted signal state,
see also page 5-2.

Output level

0 signal
1 signal
monitoring the 0 signal

0 V...3 V
> UP-2.5 V
An output level > 8 V (5 V nom.) leads to an internal
error, if the output state is 0 (0 signal)
(the module will be switched off).

Cable lengths with cables laid in parallel

shielded
unshielded

max. 1000 m
max. 600 m

Conductor cross section of process terminals

tightening torque

max. 1 x 2.5 mm²
max. 0.5 Nm

Electrical isolation

against CS31 bus and outputs (as group)

Rated insulation voltage,

process terminals from CS31 system bus:
acc. to VDE 0160, rated direct voltage
test voltage for reinforced insulation

0...50 V
800 V DC

outputs:

acc. to VDE 0160, rated direct voltage
test voltage for basis and additional insulation

0...50 V
500 V DC

Current consumption (UP)	max. 0.2 A + load current at the outputs
Current consumption (L+)	100 mA
Total power dissipation	max. 15 W
Address setting	see page 5-4
Indication of output signals	one yellow LED per channel
Error indication	one red LED (ERR)
Safety-related CE (S-CE) in the PLC software	S_LAB : Read binary S-output module S_SAB: Write binary S-output module
Module-specific CS31 bus transmission time	750 μ s
Dimensions (width x height x depth) in mm	120 x 140 x 85 mm (see next page)
Weight	400 g
Order number 07 DO 90-S	GJR5 2508 00 R202

Installation and dimensions

Fixing the module on a DIN rail

The easiest and fastest way to install the module is to snap it on to a DIN rail (acc. to DIN EN 50022-35, 15 mm deep). Neither for the assembly nor for the disassembly, any tools are required. The DIN rail is centered between upper and lower edge of the module.

Fixing the module by screwing

Using 4 M4 screws, the module can be fastened on an assembly surface (e.g. rear wall of the control cabinet). The following drawing shows the position of the fixing holes as well as all important assembly dimensions.

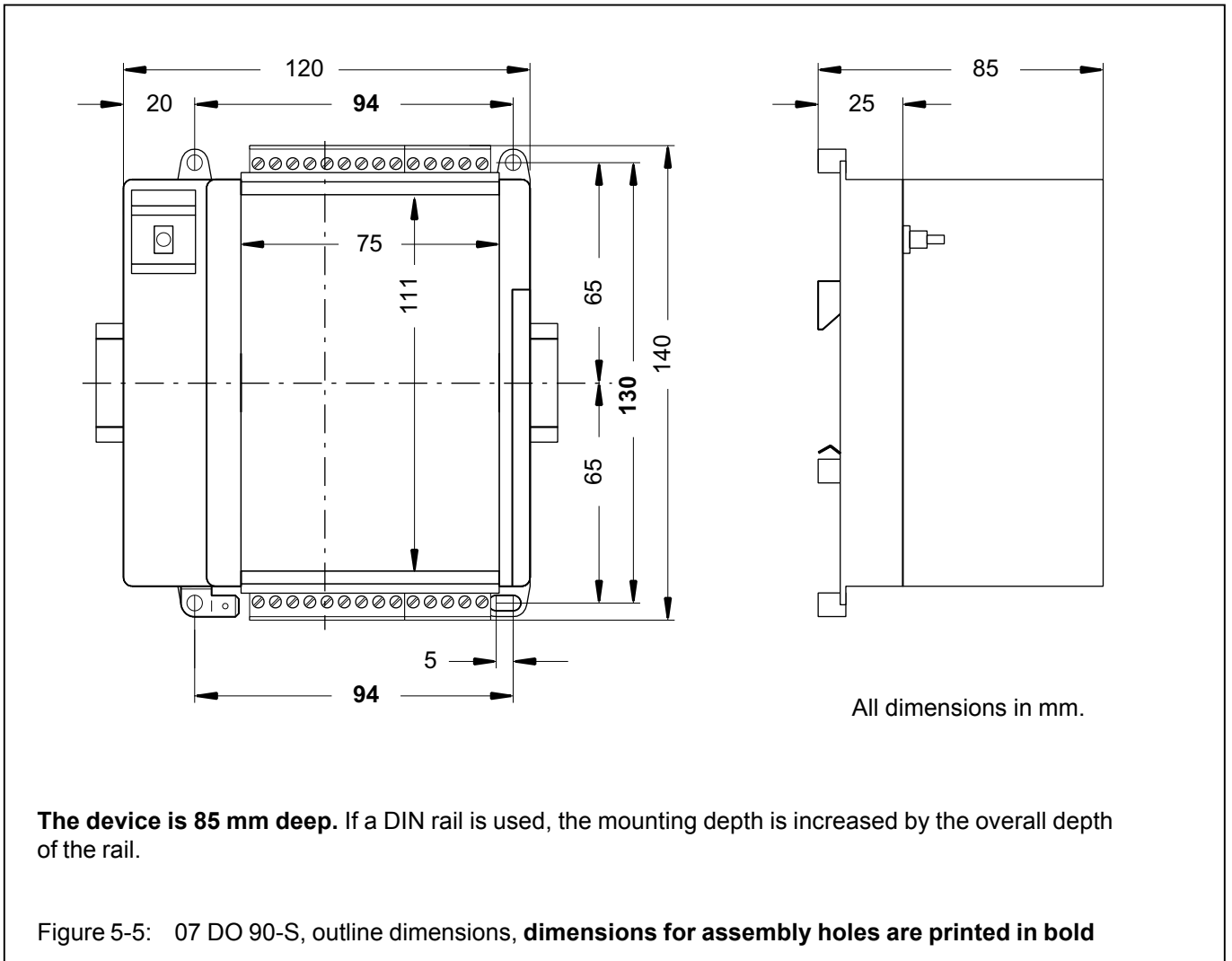

Mounting hints

Mounting position

Vertical, terminals above and below

Cooling

The natural convection cooling must not be hindered by cable ducts or other material mounted in the control cabinet.

6 Analog input module 07 AI 90-S, safety-related, 4...20 mA, 4 inputs, electrically isolated from the CS31 system bus

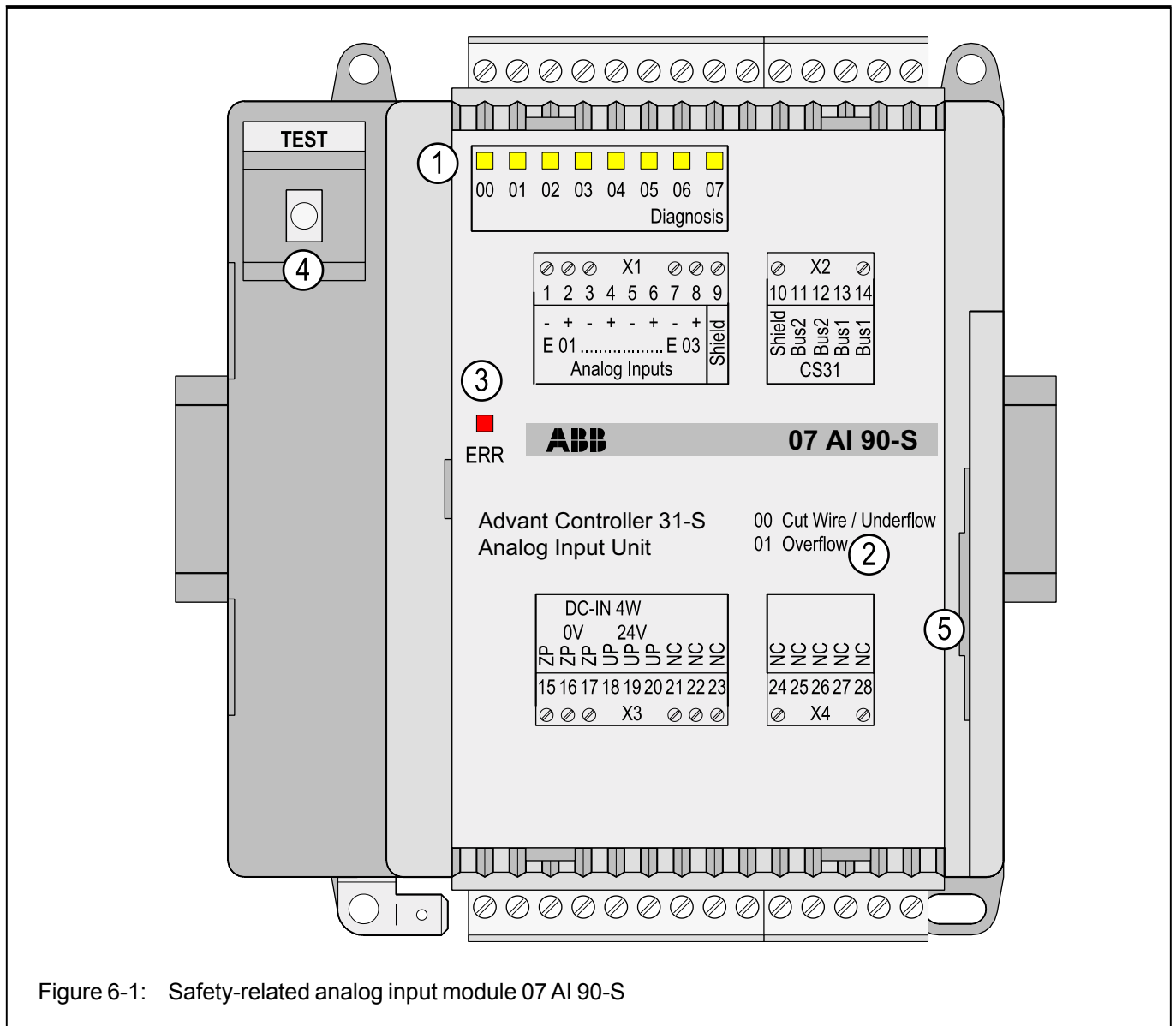

Figure 6-1: Safety-related analog input module 07 AI 90-S

Contents

Intended purpose	6-1
Indicators and operating elements on the front panel	6-2
Functional description	6-2
Principle of function	6-2
Conversion diagram	6-3
Electrical connection	6-4
Addressing (setting the module address)	6-6
Auxiliary and diagnosis functions	6-7
Start-up behaviour	6-7
Diagnosis at the module	6-7
Technical data	6-8
Installation and dimensions	6-9

Intended purpose

The module 07 AI 90-S is an analog input module with 4 input channels for 4...20 mA.

The module is part of the safety-related PLC (Advant Controller 31-S). It is used in safety-relevant automation systems to be classified under requirement classes 1...4 according to DIN V 19250.

It is used as a remote module and linked to the central unit 07 KT 94-S via the CS31 system bus.

The CS31 system bus interface is electrically isolated from the other circuitry of the module.

The input signals of the module 07 AI 90-S are read in by the AC31 central unit using special safety-related connection elements (CEs).

Indicators and operating elements on the front panel

- ① 8 yellow LEDs for indication of errors, diagnosis data and analog values
- ② List of the diagnosis information referred to the LEDs if these are used for diagnosis data
- ③ Red LED for error indication
- ④ Test button
- ⑤ DIL switch for address setting under the cover

Functional description

As the following Figure 6-2 shows, the analog value processing is largely configured in dual-channel technique. In this way, the following tasks can be fulfilled:

- Signal states are safely detected, wire cuts and short-circuits of signals are safely differentiated.
- Single faults are detected and lead to a safe shut-down.

Principle of function

The input current flowing through the shunt of approx. 200 Ω generates a voltage drop which is transferred to two evaluation channels with identical construction via high-value resistors. The high-resistivity of the resistors guarantees a non-interaction between both channels.

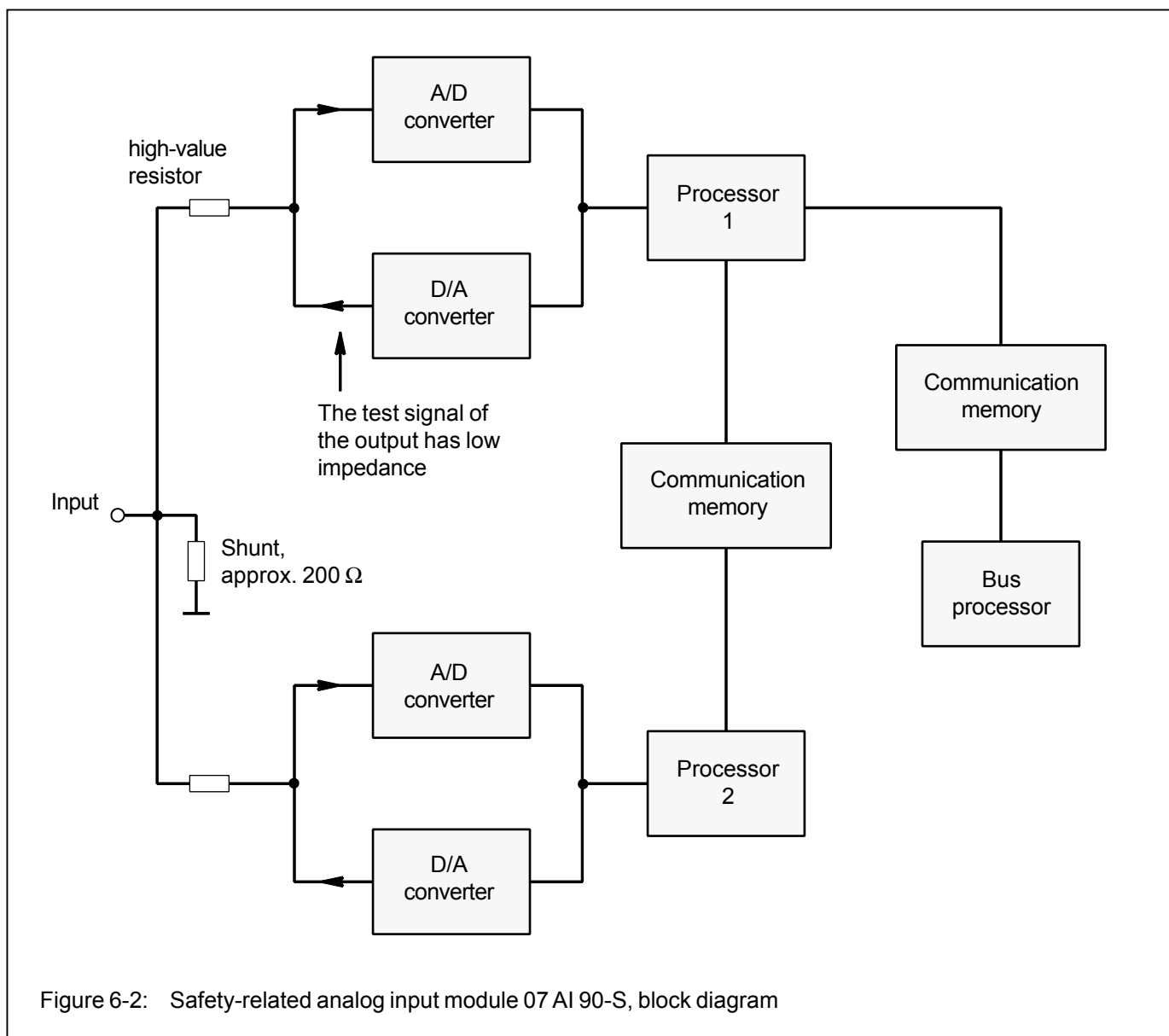

Figure 6-2: Safety-related analog input module 07 AI 90-S, block diagram

Both channels mutually supervise each other, by

- their processors comparing the converted values to each other;
- their processors generating analog values themselves in test cycles via D/A converter and comparing the data converted by the A/D converter to the expected value;
- their processors mutually checking each other for their function ability.

The dual-channel principle terminates at the bus processor with a special safety-related telegram.

Conversion

The input current flowing through the shunt of approx. 200 Ω is converted into a binary value within the range of 0...24 mA.

By digital numerical conversion, the numerical range for 4...20 mA is extracted and assigned to the hexadecimal

values 0000...0FFF_H. These hex values are output by the module.

Using a digital threshold logic, the input currents lower than 3.6 mA or higher than 20.4 mA are evaluated as underflow or overflow, respectively.

System bus interface

The CS31 system bus interface, which is electrically isolated, provides for the data exchange via the bus. There is no electrical isolation between the process supply voltage and the analog inputs.

Figure 6-4 on the next page illustrates the evaluation of the analog signals.

Conversion diagram

The following conversion diagram shows the values as output by the module (hex values, indication of underflow and overflow) depending on the input current.

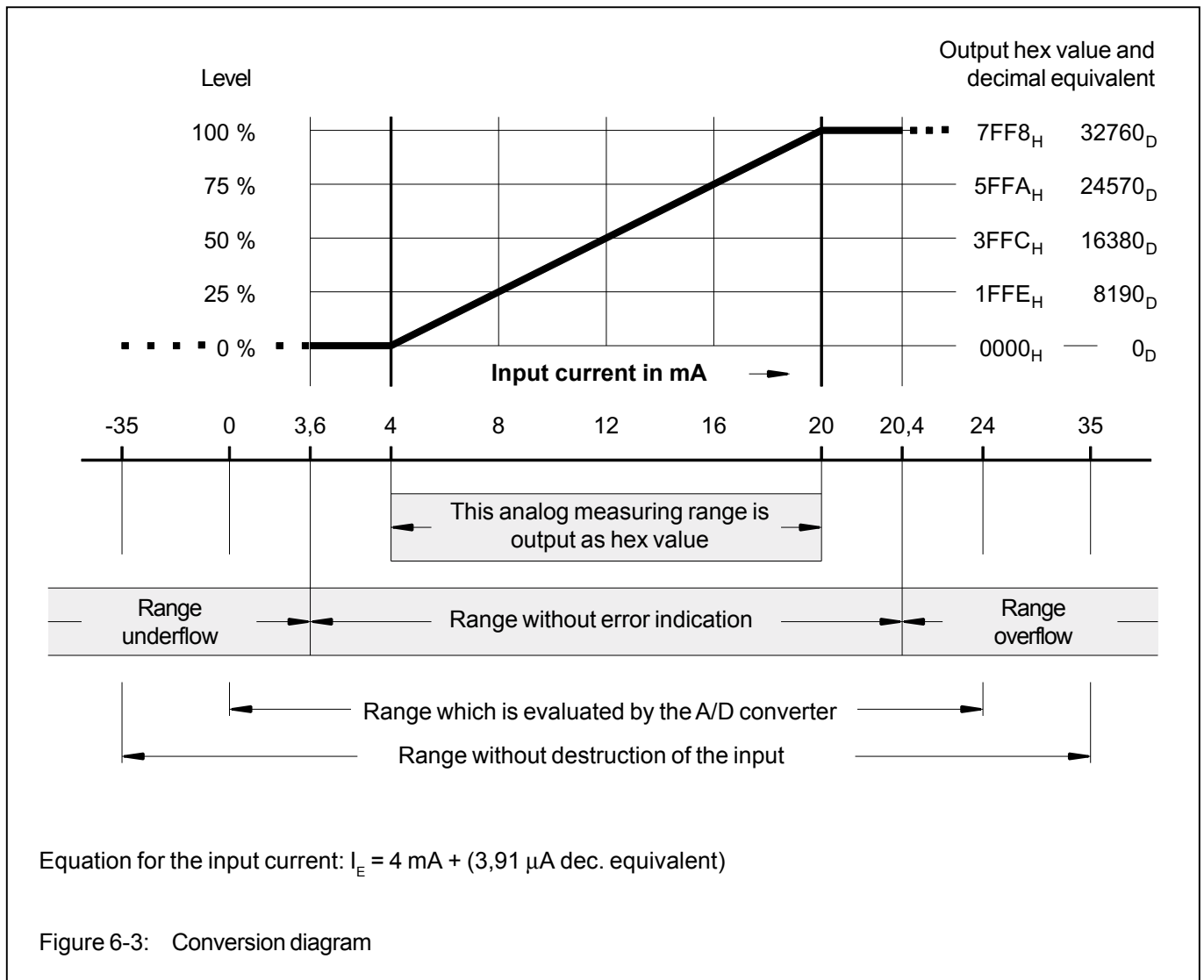

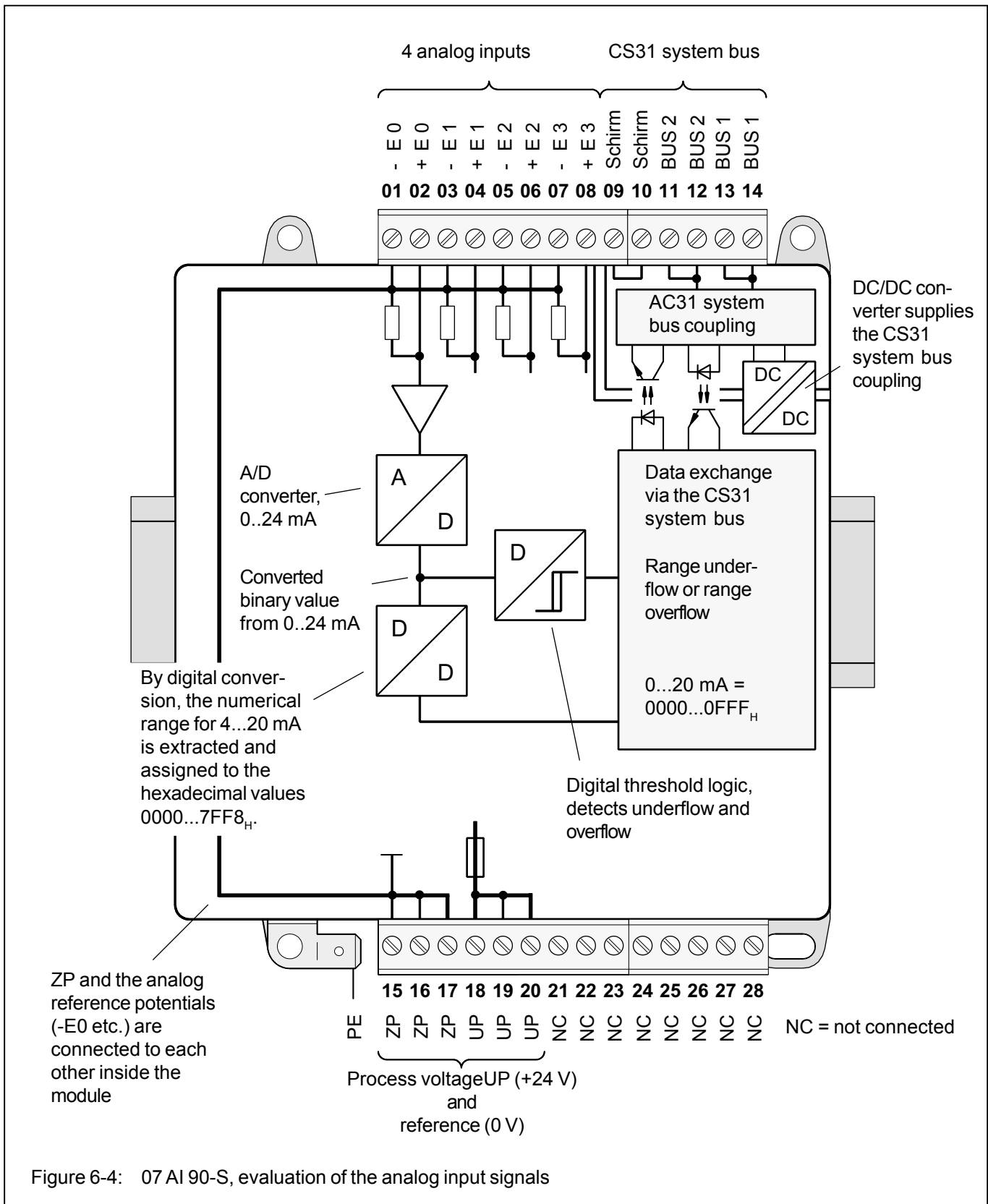

Figure 6-4: 07 AI 90-S, evaluation of the analog input signals

Electrical connection

For the planning of the AC31-S, the safety manual for the AC31-S (this file) must be observed. Here, both the architecture of the PLC program and the construction of the hardware components and their wiring are described in detail.

The module is either snapped-on to a DIN rail or directly screwed on the control cabinet's rear wall. The electrical connection is realized via pluggable terminal blocks. All terminal blocks must be plugged even those which are not used.

The figure on the next page shows the terminal assignment of the module.

Addressing (setting the module address)

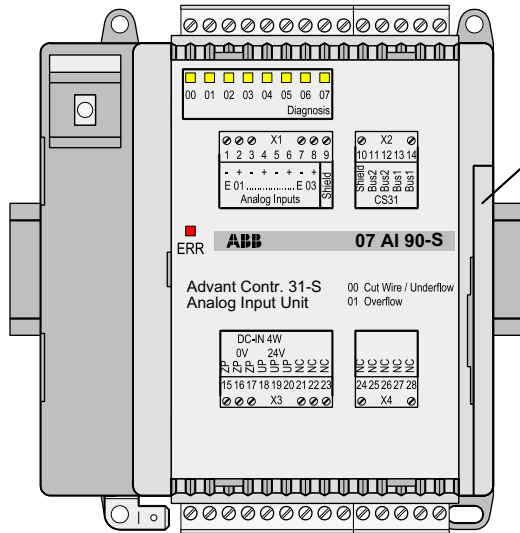

Setting the module address (0...5) is done using a DIL switch. The switch is accessible after removing the lateral cover. Pull the cover towards the front while tilting it lightly to the right. The switch is provided with a lid.

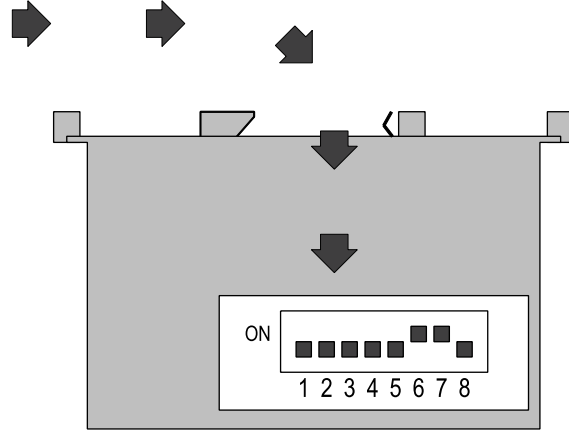

Meaning of the 8 switches:

Switch 1: must always be set to OFF
 Switch 2: must always be set to OFF

Switch 3: Module address bit Bit 4, --> OFF
 Switch 4: Module address bit Bit 3, --> OFF
 Switch 5: Module address bit Bit 2, significance 4
 Switch 6: Module address bit Bit 1, significance 2
 Switch 7: Module address bit Bit 0, significance 1

The sum of the significance values of the switches in ON position is the set module address, e.g.: switch 6 = ON, significance = 2 and switch 7 = ON, significance = 1 results in module address 3.

Switch 8: must always be set to OFF

Examples: Module address 0
 EW 00,00 *



Module address 2
 EW 02,00 *



Module address 5
 EW 05,00 *

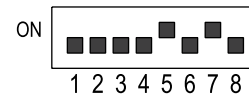

* Address entry at connection element S_LEA

Figure 6-6: 07 AI 90-S, setting of module address at the DIL switch (see also chapter 3.3 "Configuration data for the I/O modules")

Auxiliary and diagnosis functions

Start-up behaviour

After switching the power supply (UP) on, the LED 'ERR' will light up for approx. 15 sec. during the switch-on self-test of the module.

After that, the LED 'ERR' flashes until the module has been adopted in the CS31 bus cycle.

After the 'ERR' signal has gone out, this shows the correct selftest as well as the end of the initialization and adoption in the CS31 system bus.

If, however, the LED 'ERR' is lighting permanently (>15 sec) after switching on the power supply, an internal error has been detected.

If no external error is present, the LEDs remain dark until the initialization is completed. After that, they indicate an estimate value of the first input channel E0 as follows:

- If the input current is ≤ 4 mA, none of the LEDs is lighting.
- With rising input current, first of all LED 01, then additionally LED 02 etc. will light up.
- If the input current is ≥ 20 mA, all LEDs light up.

Example:

Input current = 14 mA, the first 5 LEDs are lighting

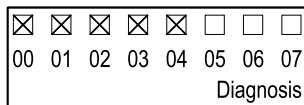

Figure 6-7: Display of the analog input signal with 8 yellow LEDs

After pressing the test pushbutton for the first time, the channel E0 is selected: the related LEDs start flashing. After releasing the pushbutton, the analog value for channel E0 is displayed. The same process can be repeated for channels E1, E2 and E3.

Further diagnosis information are included in the "Worksheet for troubleshooting in terminal mode" in volume 7.

Fuses

The module has an integrated solder-in-type micro-fuse for the supply voltage UP. If this fuse blows, the following error indication takes place:

- The module has no function any more.
- All LEDs are off.

The module has to be replaced.

Diagnosis at the module

The module distinguishes between 2 different error types:

- External errors:
 - Underflow / Cut Wire (Input current < 3.6 mA, sensor supplies too little current or the wire is cut)
 - Overflow (Input current > 20.4 mA, sensor supplies too much current)

- Internal errors:
 - all other errors

Remark: For safety reasons, only those errors unambiguously diagnosed by the module as an "External error" are indicated as "External errors". Errors such as "Input signal slightly outside tolerance band" or "Rise of input signal slower than specified" can also lead to an "Internal error" For this reason, the indication of an "Internal error" alone is not a definite indication that the module is defective.

Reaction to external errors:

- The LED 'ERR' starts flashing.
- At the faulty channel, the signal measured last is frozen.
- The error can be requested via the test button of the module.
- The error-free input channels continue the signal processing.
- The channel is marked as faulty via the CE 'S_LEA' for the AC31 central unit.
- After error recovery, the error can be acknowledged with the test button.

Reaction to internal errors:

- The LED 'ERR' and all input channel LEDs are lighting permanently.
- The module stops the processing of all input signals.
- The entire module is marked as faulty via the CE 'S_LEA' for the AC31 central unit.
- After error recovery, the error can be acknowledged by switching the power supply UP OFF and then ON again.

Diagnosis of external errors:

- By pressing the "TEST" pushbutton, the channels are selected subsequently. After pressing this key, the LED of the selected channel starts flashing. After releasing the pushbutton, the error indication of the selected channel (e.g. LED 01 for Underflow) is displayed in the channel LEDs for approx. 2 seconds.

After that, the module switches back to the status indication of an input channels. Now, the next channel can be selected.

- After selecting and querying channel 3, an LED test will be carried out after pressing the test pushbutton (all channel LEDs light up). After releasing the push-

button, the set module address is displayed for approx. 2 seconds.

- The acknowledgement of external errors is made by pressing the test pushbutton somewhat longer (approx. 5 seconds).

Technical data

Process and supply voltage UP (power supply according to VDE 0551 is necessary)	
rated voltage	24 V DC \pm 5 % ripple
upper limit value	24 V DC + 20 % = 28,8 V (\pm 5 % ripple)
lower limit value	24 V DC - 15 % = 20,4 V (\pm 5 % ripple)
The supply voltage must rise to at least 19 V within 0 to 40 msec after being switched on.	
Buffered voltage interruption time	> 10 ms
Reference potential ZP	0 V for process voltage UP
Protection against reversed polarity for UP	yes
Number of analog inputs per module	4
Input data	
Measuring range of analog input current	4...20 mA
Output hex values in this range	0000 _H ...7FF8 _H , corresponding to 0...32760 decimal
Range of no error indication	3,6...20,4 mA (see Figure 6-3 on page 6-3)
Error indication "Underflow"	if input current < 3.6 mA
Error indication "Overflow"	if input current > 20.4 mA
Range converted by analog converter	0...24 mA
Input can be destroyed	if the input current is > 35 mA or < -35 mA
Measuring error within the entire temperature range	< 1 % of full scale
Resolution	3.91 μ A (12 bits)
Input resistance	208.5 Ω
Input delay	typ. 9 ms, monitoring over 30 ms
Max. input frequency	20 Hz
Refresh time	9 ms
Edge steepness with square-wave or saw-tooth signals	0...50 μ s or > 50 ms (signals of 50 μ s...50 ms lead to an external or to an internal error)
Cable lengths with cables laid in parallel shielded	max. 1000 m
Conductor cross section of process terminals tightening torque	max. 1 x 2.5 mm ² max. 0.5 Nm
Electrical isolation	from the CS31 system bus
Rated insulation voltage, process terminals from CS31 system bus:	
acc. to VDE 0160, rated direct voltage	0...50 V
test voltage for reinforced insulation	800 V DC
Current consumption (UP)	150 mA
Total power dissipation	max. 4 W
Address setting	see page 6-5
Display of input signals	rough analog value with 8 yellow LEDs, only one channel can be displayed at a time
Error indication	one red LED (ERR)
Safety-related CE (S-CE) in the PLC software	S_LEA : Read analog S-input module
Module-specific CS31 bus transmission time	1050 μ s
Dimensions (width x height x depth) in mm	120 x 140 x 85 mm (see next page)
Weight	400 g
Order number	07 AI 90-S
	GJR5 2512 00 R202

Installation and dimensions

Fixing the module on a DIN rail

The easiest and fastest way to install the module is to snap it on to a DIN rail (acc. to DIN EN 50022-35, 15 mm deep). Neither for the assembly nor for the disassembly, any tools are required. The DIN rail is centered between upper and lower edge of the module.

Fixing the module by screwing

Using 4 M4 screws, the module can be fastened on an assembly surface (e.g. rear wall of the control cabinet). The following drawing shows the position of the fixing holes as well as all important assembly dimensions.

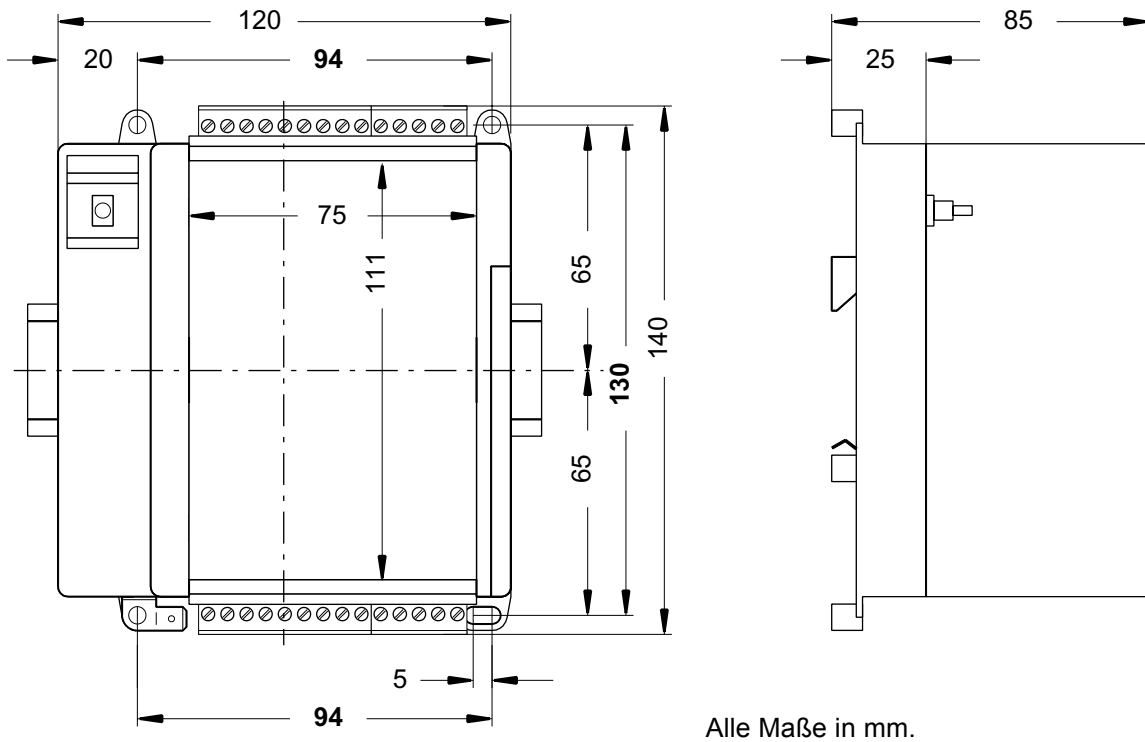

The device is 85 mm deep. If a DIN rail is used, the mounting depth is increased by the overall depth of the rail.

Figure 6-8: 07 AI 90-S, outline dimensions, **dimensions for assembly holes are printed in bold**

Mounting hints

Mounting position

Vertical, terminals above and below

Cooling

The natural convection cooling must not be hindered by cable ducts or other material mounted in the control cabinet.



ABB STOTZ-KONTAKT GmbH

Eppelheimer Straße 82 Postfach 101680
69123 Heidelberg 69006 Heidelberg
Germany Germany

Telephone +49 6221 701-0
Telefax +49 6221 701-240
E-Mail desst.help@de.abb.com
Internet <http://www.abb.de/stotz-kontakt>