

FUNCTIONAL DESCRIPTION

Pid01A

Closed Loop Controller with Auto Tuner

Prep. /	09-01-23	Function Description			No. of p.
Appr. RA/ Bengt Persson	Approved	Pid01A Functional Description			48
Resp. dept.					
	ABB AB	Doc. no.	Lang.	Rev. ind.	Page
		3AST001596D013	en	D	1

Contents

1	General	4
2	Configuration	4
3	Function Block Pid01A	5
4	Function.....	8
4.1	Basic Properties	8
4.2	Control Algorithm.....	8
4.2.1	Control Deviation	9
4.2.2	Transfer Function.....	9
4.2.3	External control parameters.....	9
4.2.4	Gain scheduling	11
4.2.5	External control data.....	11
4.2.6	Feed Forward	12
4.3	Autotuning.....	12
4.3.1	Introduction.....	12
4.3.2	Auto tuning with the Relay Method	12
4.3.3	Auto tuning Process.....	13
4.4	Control Modes	13
4.4.1	Control Mode Command Signals and Priority	13
4.4.2	Balance	14
4.4.3	Manual.....	15
4.4.4	Manual Forced.....	16
4.4.5	Auto	16
4.4.6	E1 and E2.....	16
4.4.7	E3.....	17
4.5	Start-up	17
4.6	Process connections	17
4.7	Reverse Action	18
4.8	Ramp Functions	18
4.9	Setpoint Selection, Mode transitions and Tracking	18
4.9.1	Selection of External Reference.....	18
4.9.2	Tracking.....	18
4.9.3	Setpoint Ramp Functions.....	20
4.9.4	Setpoint Limitations	20
4.10	Forced Control.....	20
4.10.1	Selection of Control Signal.....	21
4.10.2	Tracking.....	21
4.10.3	Output Ramp Functions	21
4.10.4	Output Limitations.....	21
4.11	Output Signal Control.....	21
4.11.1	Selection of Output Signal	21
4.11.2	Output Limiting	22
4.11.3	Interlocks	22
4.12	Scaling and Units	23
4.13	Alarm and Alarm Limitation Functions	23
4.13.1	Alarm Limits.....	23
4.13.2	Alarm Blocking.....	23
4.14	Event Handling	24
4.15	Interaction Window.....	24
4.15.1	Pid01A Interaction Window	24
4.15.2	General Parameters	25
4.15.3	Direction & Intl. Blockings	25

4.15.4	Units and Range	26
4.15.5	Limits & Control	27
4.15.6	Alarm & Event handling	28
4.15.7	Texts	29
4.15.8	Parameters	29
4.15.9	Parameters	30
4.15.10	Event Handling	33
4.15.11	Gain Scheduling	34
4.15.12	Bargraph.....	34
4.15.13	Trend.....	35
5	Operator Functions.....	36
5.1	Presentation	36
5.1.1	Display Elements.....	36
5.1.2	Time-logged Properties	38
5.2	Faceplate(Dialog)	40
5.3	Alarm and Event Handling.....	42
5.3.1	General.....	42
5.3.2	Alarm and Event Message.....	42
5.4	Faceplate tabs.....	43
5.4.1	Alarm Blocking.....	43
5.4.2	Limits.....	44
5.4.3	Controller Parameters.....	44
5.4.4	Autotuning	45
5.4.5	Info Text	45
5.4.6	Tracking.....	45
5.4.7	Status IO	46
6	References	47

1 General

Pid01A is a functional unit for closed loop process control in Control^{IT}, to be operated from Operate^{IT}, Operator Station. A Pid01A normally performs a complete function independently.

Pid01A has the following functions and properties:

- P-, PI-, PD- and PID-algorithm.
- Control parameters can be set from the operator station or by control logic.
- Different control modes, set by operator or by control logic.
- Controllable rate of change of setpoints and output signals.
- Limiting of setpoints and output signals.
- Function for bumpless change between different control modes.
- Alarm and event handling of important control signals.
- Autotuner of relay type

2 Configuration

Pid01A comprises a function block type for control and logic functions in Control^{IT}, a faceplate and an object display in Operate^{IT} for operator functions and control parameters.

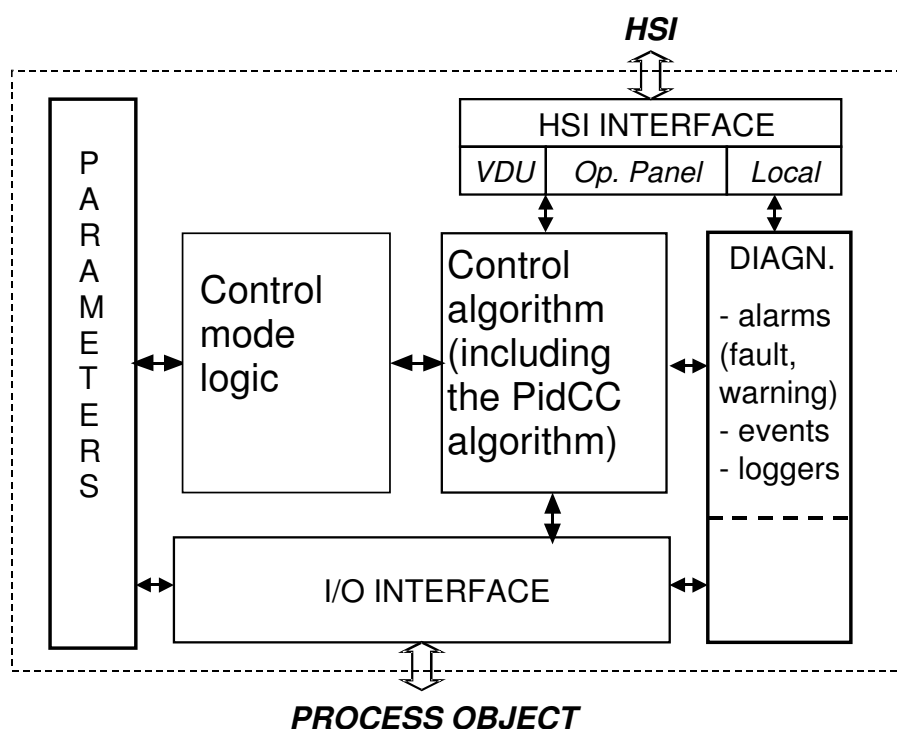

Figure 1. The Structure of the Functional Unit

3 Function Block Pid01A

FUNCTION OF INPUT TERMINALS	PID01A	FUNCTION OF OUTPUT TERMINALS
Object name	Name	AutoSp
Object description	Description	WSP
Enable control	Enable	Dev
Tracking A	TrackA	OutP
Tracking B	TrackB	Bal
Tracking C	TrackC	Man
Direct or reverse control action	RevAct	ManFd
Derivation type	Deriv	Auto
Input for hot init	HotInIt	E1
Feed Forward	FeedFwd	E2
Measured value	MV	E3
Input for status of analog input for MV	AIErr	BalOut
Change rate in auto mode	Speed1	OutEqLL
Change rate in manual mode	Speed4	OutEqHL
Enable order MAN by operator	ManEnbl	SpEqLL
Enable order AUTO by operator	AutoEnbl	SpEqHL
Enable order E1 by operator	E1Enbl	MV_LT_L2
Enable order E2 by operator	E2Enbl	MV_LT_L1
Enable order E3 by operator	E3Enbl	MV_GT_H1
External reference 1	ExtRef1	MV_GT_H2
External reference 2	ExtRef2	Dev_LT_L
External reference 3	ExtRef3	Dev_GT_H
Rate of reference E1	Speed2	OLimErr
Rate of reference E2	Speed3	NoInt
Pulse input for control mode E1	SeqE1	Err
Pulse input for control mode E2	SeqE2	ExtParOut
Pulse input for control mode E3	SeqE3	
Ordering of control mode BAL (LOC)	Local	
Ordering of control mode BAL	BalIn	
Pulse input for control mode MAN	SeqMan	
Pulse input for control mode AUTO	SeqAuto	
Balance reference	BalRef	
Block limit alarms for MV and Dev	AICBlk	
Ordering MAN with clamping	Clamp	
Clamp reference	ClampRef	
Enable output limit parameters	EOLim	
External output lower limit	EOLL	
External output upper limit	EOHL	
Interlock	IB1	
Interlock	IB2	
Reference for interlock IB1	IB1Ref	
Reference for interlock IB2	IB2Ref	
External Control	ExtCtrl	
Actuator Position	ActPos	
Ack. Alarm from logic	AlarmAck	
		Setpoint in AUTO mode
		Working setpoint
		Deviation
		Output signal of the controller
		Control mode BAL
		Control mode MAN
		Control mode Man Forced
		Control mode AUTO
		Control mode E1
		Control mode E2
		Control mode E3
		Control mode Bal, Man or Auto
		Output signal limited
		Output signal limited
		Setpoint at lower limit
		Setpoint at upper limit
		Measured value falls below limit L2
		Measured value falls below limit L1
		Measured value exceeds limit H1
		Measured value exceeds limit H2
		Deviation falls below alarm limit
		Deviation exceeds alarm limit
		Output limit error
		No interlock
		Parameter error
		Control data for Supervisory control

Figure 3-1. Function Block Type, Complete symbol

Table 3-1 below illustrates the default properties of each terminal of the Pid01A function block.

Index No.	Terminal	Data Type	Attributes	Direction	Initial Value	Description
1	Name	string	coldretain	in	'PID01A'	Object Tag Name
2	Description	string	coldretain	in	'Descr'	Object Description
3	Enable	bool	coldretain	in	TRUE	Enable control
4	TrackA	dint	coldretain	in	1	Selection of Tracking
5	TrackB	dint	coldretain	in	1	Selection of Tracking Reference
6	TrackC	dint	coldretain	in	0	Selection of Tracking
7	RevAct	dint	coldretain	in	1	Reverse Control Action
8	Deriv	dint	coldretain	in	0	Selection of Derivation
9	HotInit	dint	coldretain	in	0	Function at warmstart
10	FeedFwd	real	retain	in	0	Added Output value. Used for Bias or Feedforward
11	MV	real	retain	in	0	Measured Value
12	AIErr	dword	retain	in	16#C0	Analog Input error
13	Speed1	real	coldretain	in	2	Max change rate for setpoint, in Auto mode
14	Speed4	real	coldretain	in	20	Max output change, in eng. units/sec
15	ManEnbl	bool	retain	in	1	Enabling of Manual mode from HIS
16	AutoEnbl	bool	retain	in	1	Enabling of Auto mode from HIS
17	E1Enbl	bool	retain	in	0	Enabling of E1 mode from HIS
18	E2Enbl	bool	retain	in	0	Enabling of E2 mode from HIS
19	E3Enbl	bool	retain	in	0	Enabling of E3 mode from HIS
20	ExtRef1	real	retain	in	0	External Reference (setp.) in E1 mode
21	ExtRef2	real	retain	in	0	External Reference (setp.) in E2 mode
22	ExtRef3	real	retain	in	0	External Reference (outp.) in E3 mode
23	Speed2	real	coldretain	in	2	Max change rate for setpoint, in E1 mode
24	Speed3	real	coldretain	in	2	Max change rate for setpoint, in E2 mode
25	SeqE1	bool	retain	in		Puls input for ordering of E1 mode
26	SeqE2	bool	retain	in		Puls input for ordering of E2 mode
27	SeqE3	bool	retain	in		Puls input for ordering of E3 mode
28	Local	bool	retain	in	0	Local mode from logic
29	Balln	bool	retain	in	0	Balance mode from logic
30	SeqMan	bool	retain	in		Puls input for ordering of Manual mode
31	SeqAuto	bool	retain	in		Puls input for ordering of Auto mode
32	BalRef	real	coldretain	in	0	Balance Reference
33	AlCBlk	bool	retain	in	0	Alarm Control Block. Input for blocking of alarm
34	Clamp	bool	retain	in	0	Clamp mode from logic
35	ClampRef	real	coldretain	in	0	Clamp Reference
36	EOLim	bool	retain	in	0	External Output Limit
37	EOLL	real	coldretain	in	0	External Output Low Limit
38	EOHL	real	coldretain	in	100	External Output High Limit
39	IB1	bool	retain	in	1	Interlock 1
40	IB2	bool	retain	in	1	Interlock 2
41	IB1Ref	real	retain	in	0	Reference for Interlock 1
42	IB2Ref	real	retain	in	0	Reference for Interlock 2
43	ExtCtrl	Ext_Control	retain	in		External Control
44	ActPos	real	retain	in	0	Actuator Position
45	AlarmAck	bool	retain	in		Ack. Alarm from logic
46	AutoSp	real	retain	out		Auto Setpoint
47	WSP	real	retain	out		Working Setpoint
48	Dev	real	retain	out		Deviation
49	OutP	real	retain	out		Output signal
50	Bal	bool	retain	out		Indication of Balance mode
51	Man	bool	retain	out		Indication of Manual mode
52	ManFd	bool	retain	out		Indication of Manual Forced mode

<u>Index No.</u>	<u>Terminal</u>	<u>Data Type</u>	<u>Attributes</u>	<u>Direction</u>	<u>Initial Value</u>	<u>Description</u>
53	Auto	bool	retain	out		Indication of Auto mode
54	E1	bool	retain	out		Indication of E1 mode
55	E2	bool	retain	out		Indication of E2 mode
56	E3	bool	retain	out		Indication of E3 mode
57	BalOut	bool	retain	out		Balance Out
58	OutEqLL	bool	retain	out		Output equal to low limit
59	OutEqHL	bool	retain	out		Output equal to high limit
60	SpEqLL	bool	retain	out		Setpoint equal to low limit
61	SpEqHL	bool	retain	out		Setpoint equal to high limit
62	MV_GT_H2	bool	retain	out		Measured Value greater than or eq. to high limit 2
63	MV_GT_H1	bool	retain	out		Measured Value greater than or eq. to high limit 1
64	MV_LT_L1	bool	retain	out		Measured Value less than or eq. to low limit 1
65	MV_LT_L2	bool	retain	out		Measured Value less than or eq. to low limit 2
66	Dev_GT_H	bool	retain	out		Deviation greater than high limit
67	Dev_LT_L	bool	retain	out		Deviation less than low limit
68	OLimErr	bool	retain	out		Output low limit is greater than high limit
69	NoInt	bool	retain	out		No Interlock
70	Err	bool	retain	out		Parameter error
71	ExtParOut	Ctrl_Data	retain	out		Control data for Supervisory control

Table 3-1. Terminal properties.

4 Function

4.1 Basic Properties

The Pid01A functional unit is designed for regulatory control in different processes.

Pid01A normally performs all control functions independently, however there are situations where Pid01A's functionality needs to be supplemented. Such cases can include

- Ratio Control, where a Ratio Station RATIO01 supplements the Pid01A.
- Increase/Decrease control, where a three state controller CON-PU1 supplements the Pid01A.
- For special control applications additional logic can be used to supplement Pid01A.

Pid01A has the following basic functions.

- P, PI, PD or PID control algorithm.
- External control parameters, which can be useful when applying i.e., gain scheduling.
- External control data, which can be useful for supervisory control.
- Feed Forward
- Control modes: BAL, Man, Auto and different cascade alternatives.
- Logic for allocation of priority in the selection of control mode.
- Different versions of setpoint tracking.
- Rate of change limiting of the different setpoints and of the output signal.
- The possibility to limit setpoints and output signals.
- Functions for bumpless transfers between the different control modes.
- Possibility to Forced the control of the output signal.
- Alarm and event handling.
- Autotuning

4.2 Control Algorithm

The algorithm is based on the PidCC control module.

The algorithm consists of a controller with optional P-, PI-, PD- or PID-characteristics. The different parameters can be set from the operator station or by control logic.

Derivation can be performed on measured value or deviation.

Direct or reversed control action is selectable.

The PID controller algorithms used are of ideal type. The controller input from the process Pv and the setpoint Sp are regularly read by the controller. A reading is also called a sample, and the time between two samples is called the sampling time. The required

output signal value is calculated for each sample by comparing samples of the input and setpoint values. The sample time is equal to the task cycle time of the current task. The process value may be filtered before it enters the derivative part of the control algorithm by a first-order, low-pass filter.

For more details please refer to **Ref1**.

4.2.1 Control Deviation

Control deviation is the difference between the working setpoint and the measured value from the process. This is processed in accordance with the control parameters given to the P-, PI-, PD- or PID- algorithms. The result of this processing is applied to the output signal.

Calculation of Control Deviation

The control deviation is calculated with the following equation:

$$DEV = MV - WSP$$

DEV = control deviation

MV = measured value

WSP = working setpoint

4.2.2 Transfer Function

The transfer function for a PID controller consists of the sum of the different transfer functions for PI-controller and derivator.

$$G(s) = Gain \left(1 + \frac{1}{s \cdot T1} + \frac{s \cdot TD}{1 + s \cdot TF} \right)$$

GAIN = gain constant

TI = integration time constant

TD = derivation time constant

TF = filter time constant.

The PID algorithm in the software performs the following tests:

- If $\frac{TS}{TI} > 1$, then $\frac{TS}{TI}$ is set = 1
- $Abs(Dev) > IntegralDeadband$, otherwise no integration change.

TS = the sampling time for the controller.

4.2.3 External control parameters

With the input "ExtCtrl" the control and alarm parameters can be externally controlled, which can be useful when applying i.e., gain scheduling. The input is a structured data type with the following components, which can be individually utilized.

Index No.	Name	Data Type	Attributes	Initial Value	Description
1	GainEnbl	bool	retain	FALSE	External Gain Enable
2	Gain	real	retain	0,5	External Gain
3	TIEnbl	bool	retain	FALSE	External IntegrationTime Enable
4	TI	real	retain	30	External Integration Time
5	TDEnbl	bool	retain	FALSE	External DerivationTime Enable
6	TD	real	retain	0	External DerivationTime
7	TFEnbl	bool	retain	FALSE	External Filter Time Enable
8	TF	real	retain	0	External Filter Time
9	IntBlkEnbl	bool	retain	FALSE	External Integration Block Enable
10	IntBlk	bool	retain	FALSE	External Integration Block
11	DerBlkEnbl	bool	retain	FALSE	External Derivation Block Enable
12	DerBlk	bool	retain	FALSE	External Derivation Block
13	SPLimEnbl	bool	retain	FALSE	External Setpoint Limit Enable
14	SPH	real	retain	100	External Setpoint High Limit
15	SPL	real	retain	0	External Setpoint Low Limit
16	En_H2	bool	retain		Enable HH Limit
17	MVH2	real	retain	100	High Limit 2
18	ALB_H2	bool	retain		Blocking of alarm limit H2
19	En_H1	bool	retain		Enable H Limit
20	MVH1	real	retain	100	High Limit 1
21					Blocking of alarm limit H1 and Dev High
22	ALB_H1	bool	retain		High
23	En_L1	bool	retain		Enable L Limit
24	MVL1	real	retain	0	Low Limit 1
25					Blocking of alarm limit L1 and Dev Low
26	ALB_L1	bool	retain		Low
27	En_L2	bool	retain		Enable LL Limit
28	MVL2	real	retain	0	Low Limit 2
29	ALB_L2	bool	retain		Blocking of alarm limit L2
30	SetpStationModeEnbl	bool	retain	FALSE	Enable QCS Setpoint Station Mode
31	Bal	bool	retain	FALSE	Balance Mode (Used when SetpStationModeEnbl is True and PID Enable is False)
32	Man	bool	retain	FALSE	Manual Mode (Used when SetpStationModeEnbl is True and PID Enable is False)
33	Auto	bool	retain	FALSE	Auto Mode (Used when SetpStationModeEnbl is True and PID Enable is False)
34	E1	bool	retain	FALSE	E1 Mode (Used when SetpStationModeEnbl is True and PID Enable is False)
35	AI_Error_Ovveride	bool	retain	FALSE	Bypass AI Error check (used when SetpStationModeEnbl is True)
36	On_Off_Ctrl_Enbl	bool	retain	FALSE	Enable On Off Ctrl
37	On_Off_Ctrl	bool	retain	FALSE	On Off Ctrl
38	ManOut_Enbl	bool	retain	FALSE	External Entered Output Enable
39	ManOut	real	retain		External Entered Output
40	SP_Enbl	bool	retain	FALSE	External Entered Setpoint Enable
41	SP	real	retain		External Entered Setpoint
42	WSP_Enbl	bool	retain	FALSE	External Working Setpoint Enable
43	WSP	real	retain		External Working Setpoint

Table 4-1. ExtCtrl Terminal properties of Pid01A

4.2.4 Gain scheduling

Gain scheduling can be accomplished by connecting the output “ExtCtrl” of the element “GainSched” to the input “ExtCtrl” of the Pid01A.

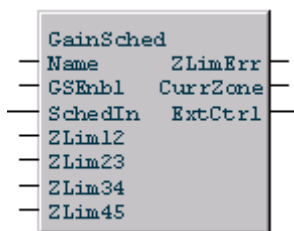

Index No.	Terminal	Data Type	Attributes	Direction	Initial Value	Description
1	Name	string	coldretain	in	'Name'	Object Tag Name
2	GSEnbl	bool	coldretain	in	0	Gain Scheduling Enable
3	SchedIn	real	coldretain	in	0.0	Scheduling Input
4	Zlim12	real	coldretain	in	20.0	Zone 1 to 2 Limit
5	Zlim23	real	coldretain	in	40.0	Zone 2 to 3 Limit
6	Zlim34	real	coldretain	in	60.0	Zone 3 to 4 Limit
7	Zlim45	real	coldretain	in	80.0	Zone 4 to 5 Limit
8	ZlimErr	bool	coldretain	out		Zone Limit Error
9	CurrZone	dint	coldretain	out		Current Zone
10	ExtCtrl	Ext_Control	retain	out		Output

4.2.5 External control data

With the output “ExtParOut” internal data from the control can be used by e.g. supervisory control. The output is a structured data type with the following components, which can be individually utilized.

Index No.	Name	Data Type	Attributes	Initial Value	Description
1	Name	string	retain	'Pid01'	Object Tag Name
2	Description	string	retain	'Descr'	Object Description
3	MV	real	retain		Measured Value
4	WSP	real	retain		Working Setpoint
5	OutP	real	retain		Output signal
6	ActPos	real	retain		Actuator Position
7	Max	real	retain		Max Range, MV
8	Min	real	retain		Min Range, MV
9	SPH	real	retain		Setpoint High Limit
10	SPL	real	retain		Setpoint Low Limit
11	OHL	real	retain		Output High Limit
12	OLL	real	retain		Output Low Limit
13	Gain	real	retain		Gain
14	TI	real	retain		Integration Time
15	TD	real	retain		Derivative Time
16	DeadZ	real	retain		Deadzone
17	RevAct	dint	retain		Reverse Control Action
18	NoInt	bool	retain		No Interlock
19	SpEqLL	bool	retain		Setpoint equal to low limit
20	SpEqHL	bool	retain		Setpoint equal to high limit

Index No.	Name	Data Type	Attributes	Initial Value	Description
21	OutEqLL	bool	retain		Output equal to low limit
22	OutEqHL	bool	retain		Output equal to high limit
23					Control Mode, -1=Bal, 0=Man, 1=Auto, 2=E1, 3=E2, 4=E3, 5=ManFd
24	Mode	dint	retain		Highest Control Mode, 0=Man, 1=Auto, 2=E1, 3=E2
	TopMode	dint	retain		

Table 4-2. ExtParOut Terminal properties of Pid01A

4.2.6 Feed Forward

In automatic modes, the output of the controller is generated by the control algorithm, with the value of the input :FeedFwd added. The result is checked against high and low limits and rate limit, as described

The feed forward signal is used to compensate for measurable disturbances to achieve faster and smoother control of a process. Feed forward means that a signal is either added to or subtracted from the output signal of the controller. The feed forward signal may also be amplified or reduced. The feed forward process accelerates the controller's response by anticipating changes and acting to neutralize any disturbance before it occurs. Feed forward can also be used to suppress changes in the input signal that must not be allowed to influence the controller output. Feed forward is selected as a positive (+) or a negative (–) value of FFGain in the algorithm.

For more details please refer to **Ref1**

4.3 Autotuning

4.3.1 Introduction

Auto tuning is a simple way to obtain suitable controller parameters. You are thus recommended to use the Autotuner function, otherwise, a great deal of time can be spent in manual tuning of many controllers in large process plants. Manual tuning time can be increased even more when retuning becomes necessary due to changes in the process conditions.

When the process is in steady state, the user starts the Autotuner. It then identifies the dynamic parameters of the process automatically, and from these the Autotuner calculates and suggests appropriate PID parameters. When autotuning is complete the controller goes back to the mode it was in before. It uses the old controller parameters, but suggests the new autotuned parameters and you have the choice to apply them. If you do not apply the new values, and then close the tuning interaction window, the autotuning values will be lost.

Auto tuning is based on a relay (ON/OFF) identification method with feedback measurements.

Note: Perform auto tuning only when the process is in steady state.

4.3.2 Auto tuning with the Relay Method

When the system is in steady state and the Autotuner has been started, the PID controller is temporarily disconnected.

First the Autotuner measures the noise of the process value.

Secondly, the output is generated and changed by the relay, with a hysteresis function, to implement a disturbance in the process, of a small amplitude. The effect of the relay function is an ON/OFF control which, by means of a square wave signal, generates a controlled and stable oscillation in the process value. The response is observed and the amplitude of the oscillation is automatically controlled to a minimum value by adjustment of the relay amplitude. From the period and amplitude of the process value oscillation, suitable P, I and D parameters are calculated. The controller is then ready to operate and the PID algorithm is reintroduced into the control loop.

4.3.3 Auto tuning Process

Auto tuning can be started with the controller in Manual, Auto, E1 or E2 mode. During the auto tuning process the Autotuner controls the output. The following two conditions must be fulfilled before starting auto tuning.

- The process must be in steady state. It is not possible to start the Autotuner during a load disturbance or a setpoint change.
- It is also important that no major load disturbance occurs during the auto tuning process.
- The control deviation ($Sp - Pv$) must be less than 5% of the actual Pv range.

When these conditions are fulfilled, you can start the Autotuner.

If the process is not in steady state auto tuning may fail. Auto tuning is interrupted by a load disturbance.

For more details on the Auto tuning process please refer to **Ref1**.

4.4 Control Modes

4.4.1 Control Mode Command Signals and Priority

The signals for control mode change are placed in order of priority. LOCAL has the highest priority and SEQE3 has the lowest priority. The current control mode is determined by the active inputs with the highest priority by a pulse. The inputs are of three different types; static, set-reset and dynamic.

- The static input must be activated for the corresponding control mode to be applied. If the signal at the input disappears, the control mode changes over to MAN, provided no static input with a lower priority takes over the selection of the control mode.
- Set-Reset means that the control mode is selected when the input is activated. If the input is reset to zero, the control mode remains in effect until some other input is activated. If the SR-input is kept active, only inputs with a higher priority can assume the selection of control mode.
- The dynamic input is only initiating. The control mode is selected when a change from 0 to 1 occurs at the input.

The control mode can be enabled individually. Input terminals ManEnbl, AutoEnbl, E1Enbl, E2Enbl and E3Enbl can be set in the function block with constants or by application logic. By enabling a single control mode under certain conditions it is possible to lock the control mode to prevent switching to another control mode.

Table 4-2 illustrates control mode activation and priority when selected from either an application program or from the operator station.

Commands		Mode selected					
Signal	Source	Balance	Manual	Auto	E1	E2	E3
Local ⁽¹⁾	Program						
BalIn ⁽¹⁾	Program						
Clamp ⁽¹⁾	Program						
Manual Forced ⁽²⁾	Operator						
Interlocks	Program		Remains unchanged				
AI-error	AI-channel						
Man	Operator						
SeqMan ↑ ⁽³⁾	Program						
Auto	Operator						
SeqAuto ↑ ⁽³⁾	Program						
E1	Operator						
E2	Operator						
E3	Operator						
SeqE1 ↑ ⁽³⁾	Program						
SeqE2 ↑ ⁽³⁾	Program						
SeqE3 ↑ ⁽³⁾	Program						

Table 4-2. Control modes selection and priority.

- (1) On leaving mode Balance or Manual Clamped (i. e. when the command signal returns to zero), mode Manual is always obtained, unless any signal commands another mode.
- (2) The mode MAN Forced is temporarily left while a command signal with higher priority is active. The mode is not left finally, until the operator gives a command for another mode. All other commands of lower priority are blocked.
- (3) The arrow ↑ indicates that only the positive transition of the signal is relevant for commanding a mode change.

The purpose and function of each control mode is described below.

4.4.2 Balance

Balance control mode is used to force the controller output to a value present at the input terminal BalRef. The operator cannot override this mode.

When the controller is operating in Balance mode the output signal follows the balance reference signal. This mode is used when the control signal is disconnected and the controller is balanced for a bumpless return to control.

Control mode BAL is activated by:

- The activation of input terminal LOcCAL. An indication of BAL LOCAL is presented on the object display and Bal on the Faceplate mode indicator.
- The activation of input terminal BALIN. An indication of BAL is presented on the object display and Bal on the Faceplate mode indicator.

Examples of use can be as follows:

- Manual emergency control, which has the highest priority. An operator, working centrally at the display screen cannot take over control from a local backup station located adjacent to the process function.
- When another function block or other logic other than the process controller is to take over the control. An example is cascade coupling of several process controllers.

4.4.3 Manual

Manual is the initial control mode of the controller. In this mode the operator directly sets the output value from the operator station. The rate of output value is limited by the value at terminal Speed4. Manual mode is enabled by input terminal ManEnbl.

The control mode MAN is activated by:

- Input terminal CLAMP gives the indication MAN CLAMP in the object display.
- Changeover to manual forced mode by using the MFd button on the operator's faceplate. Indication MFd on the object display.
- Input terminal AIERR <> 1 changes the control mode to MAN. "No error at overflow" can be selected from the interaction window. Overflow will then not generate AIERR, while Underflow still will.
- By clicking on the Man button on the operator's faceplate. Man is indicated on the object display and Faceplate.

Examples of use:

- Manual control of an actuator under abnormal operation conditions e.g. in connection with a malfunction.
- Manual control at start and stop.
- Man Clamp can be used to let an interlock signal force the output to a specific value. When the interlock is gone, the control mode is MAN. Either application logic or the operator has to decide how to return to normal operating mode.

4.4.4 Manual Forced

Manual Forced is a non-regulatory control mode, like the manual mode, where the operator sets the output. This mode overrides the Interlocks, but not the external output limitations (EOLim) or operator entered limitations.

The control mode MANFd is activated by:

- Changeover to manual forced mode by using the MFd button on the operator's faceplate. Indication MFd on the object display.

Examples of use:

- During a plant stop interlocks could prevent opening of the valve. ManFd enables the operator to still use the valve for ie. testing etc.

4.4.5 Auto

Auto is the automatic control mode, where the operator sets the setpoint. The rate of change of the setpoint value is limited by the value at terminal Speed1. Auto mode is enabled by input terminal AutoEnbl.

The control mode AUTO is activated by:

- By clicking on the Auto button on the operator's faceplate. Auto is indicated on the object display and Faceplate.
- Input terminal SEQAUTO when activated by a pulse.

4.4.6 E1 and E2

E1 and E2 are automatic control modes, where the setpoint is obtained from an external source. The rate of setpoint values is limited by the value at terminals Speed2 and respectively Speed3. E1 and E2 modes are enabled by input terminals E1Enbl and E2Enbl.

With control mode E1 (External 1) the setpoint consists of a signal received from an external source at input terminals ExtRef1 and ExtRef2. The control mode E1 and E2 can be commanded from the operator's keyboard, from another application logic or from an external control device.

The control mode E1 or E2 is activated by:

- By clicking on the E1 or E2 buttons on the operator's faceplate. Ext1 or Ext2 is indicated on the object display and Faceplate.
- Input terminal SEQE1 or SEQE2 when activated by a pulse.

Examples of use:

- Cascade control.
- Setpoint control from an optimizing function.
- Local setting of setpoint.
- Recipe-controlled setpoint.

4.4.7 E3

E3 is the non-regulatory control mode, where the setpoint is derived from program logic and directly applied to the output. It has the same functionality as Manual mode excepting that the setpoint to the output comes from program logic and not the operator. The output signal is forced to follow an external reference. E3 mode is enabled by input terminal E3Enbl.

The control mode E3 is activated by:

- By clicking on the E3 button on the operator's faceplate. Ext3 is indicated on the object display and Faceplate.
- Input terminal SEQE3 when activated by a pulse.

Examples of use:

- When it is desirable to control the output signal with low priority e.g. from a local operator's station or from a PC. The responsibility for the control can then always be taken over at a central operator's station.
- In connection with traditionally named DDC (Direct Digital Control).

4.5 Start-up

An initialisation phase begins at start of the AC800M system. Manual is the default control mode at system initialisation or after a download. It is possible to force the control mode to other modes at system initialisation.

The input terminal HOTINIT: controls the selection of the control mode and output with respect to the status, which was present before the initialization.

- 0 Control mode and output unchanged.
- 1 Control mode changed to Manual, output unchanged.
- 2 Control mode changed to Manual, output = 0 or = OLL

4.6 Process connections

The Pid01A is connected to the process via the following two input terminals.

- MV Connection for measured value e.g. a level transmitter.
- OUTP Control output to e.g. a control valve.

4.7 Reverse Action

The following control functions are activated when the REVACT: input terminal is enabled with the values as shown below.

- 0 Direct action in "PI" and "D" sections. (INC/INC)
- 1 Reverse action in "PI" and "D" sections. (INC/DEC)
- 2 Direct action in "PI" section. Reverse action in "D" section.
- 3 Reverse action in "PI" section. Direct action in "D" section.

4.8 Ramp Functions

Ramp functions are introduced into the signal paths to determine the maximum permitted rate of change of certain signals. These are designated RAMP and are located in the function block and used for CONTROL DEVIATION, SETPOINT SELECTION and FORCED CONTROL. The maximum permitted rate of change is determined by the operational parameter SPEED (X) and is specified in process-related variables/second or percentage units/second, depending on the signal.

4.9 Setpoint Selection, Mode transitions and Tracking

The term "working setpoint" is the setpoint that the controller uses in its algorithm in all modes. The "auto setpoint" is the setpoint that the operator enters in auto mode. In auto mode the auto setpoint is transferred to the working setpoint.

SETPOINT SELECTION contains the following functions:

- Selection of external reference (1 or 2)
- Tracking
- Ramp functions
- Limitations

4.9.1 Selection of External Reference

The working setpoint is external reference 1(E1) in control mode Ext1 or external reference 2(E2) in control mode Ext2.

4.9.2 Tracking

The tracking functions are intended to eliminate abrupt changes of the setpoint on return to the different control modes. Tracking functions are available for both auto and external modes and are activated during mode transfers.

During a mode transfer the working setpoint will ramp to selected setpoint if TrackA (Auto SP Track Reference) and TrackC (External SP Track Reference) are enabled.

The auto setpoint can be set to follow the process value and/or the external setpoints by means of TrackB (SP Track Selection).

4.9.2.1 Tracking of AUTO setpoint

Two tracking functions are included for the AUTO setpoint (AUTOSP). The tracking functions can be activated with other control modes than AUTO. Their purpose is to permit bumpless connection of the AUTO setpoint or connection with constant signal value.

The function is selected with two parameters, TRACKA and TRACKB.

- TRACK A: Selection of tracking reference.
 - 0 No tracking.
 - 1 Tracking on "MV" if TRACK B not = 0.
 - 2 Tracking on "External setpoint" if TRACK B not = 0.
- TRACK B: Selection of how to track.
 - 0 No tracking.
 - 1 Working setpoint tracks signal according to TRACK A.
 - 2 Working setpoint and Auto setpoint tracks signal according to TRACK A.

TrackA	TrackB	Description
0	0	No tracking.
X	0	No tracking.
1	1	AutoSp is not affected. The working setpoint, WSP, is tracking the measured value, MV, when not in Auto mode. The WSP is ramped to equal AutoSp with a speed that is determined by Speed1.
2	1	AutoSp is not affected. The working setpoint, WSP, is tracking the value of ExtRef1 or ExtRef2, depending on whether operating mode E1 or E2 applies. The WSP is ramped to equal AutoSp with a speed that is determined by Speed1. "Tracking" takes place in the operating modes E1 and E2.
1	2	AutoSp and Working setpoint tracks the measured value, MV when not in Auto mode. Changeover to Auto takes place both without bumps and changes
2	2	AutoSp and Working setpoint tracks the external setpoint ExtRef1 or ExtRef2, depending on whether operating mode E1 or E2 applies. Changeover to Auto takes place both without bumps and changes. Tracking takes place in the operating modes E1 and E2.

Table 4-3. Selection for tracking function of AutoSp.

4.9.2.2 Tracking of External setpoints

The tracking functions are intended to eliminate abrupt changes of the setpoint on return to the control modes E1 and E2 respectively. The tracking functions are controlled with a function parameter TRACKC.

Two tracking functions below are integrated in Track C.

- External reference 1 can follow the measured value or the working setpoint with a control mode other than E1.

- External reference 2 can follow the measured value or the the working setpoint with a control mode other than E2.

Table 4-4 below describes the changeover for each function.

TrackC	Description
0	No tracking
1	The external setpoints ExtRef1 and ExtRef2 are tracking the measured value, MV, when not in mode E1 or E2. The internal setpoint, Extref, is thereafter ramped to equal ExtRef1 or ExtRef2 as applicable with a speed that is determined by Speed2 or Speed3 respectively. ExtRef1 is tracking in all control modes but E1, while ExtRef2 is tracking in the all modes but E2.
2	The external setpoints ExtRef1 and ExtRef2 are tracking the working setpoint, WSP, when not in mode E1 or E2. The internal setpoint, Extref, is thereafter ramped to equal ExtRef1 or ExtRef2 as applicable with a speed that is determined by Speed2 or Speed3 respectively. ExtRef1 is tracking in all control modes but E1, while ExtRef2 is tracking in the all modes but E2.

Table 4-4. Selection of tracking function for ExtRef.

4.9.3 Setpoint Ramp Functions

The input terminals described below determine the maximum permitted rate of change as follows:

- Speed 1 Auto setpoint speed. Specified in engineering units/second.
- Speed 2 Ext1 setpoint speed. Specified in engineering units/second.
- Speed 3 Ext2 setpoint speed Specified in engineering units/second.

4.9.4 Setpoint Limitations

The limiting values SPH and SPL apply for both AUTO setpoint and the external references E1 and E2. The setpoint limits are set in the Extended Faceplate on the faceplate element "Limits2".

4.10 Forced Control

Forced control may also be initiated to a reference value i.e. on receiving an incorrect signal from an analog input (AI), the output signal for example ramps down to zero.

The function block contains the following functions:

- Selection of control signal
- Tracking
- Ramp functions
- Limitations

4.10.1 Selection of Control Signal

There are three forms to force the control of the output signal:

- Manual is selected with the control mode MAN
- External references are selected with the control mode E3
- Clamping is selected with the clamping function (control mode MAN)

The following inputs are be used for forced control.

Speed4 Highest permitted rate of change of the output signal.

Clamp Command signal for clamping. The mode changes to MAN. When the Clamp signal is released the mode will still be MAN.

ClampRef Clamping reference value when terminal Clamp is activated.

ExtRef3 External reference value for the output signal in mode E3

4.10.2 Tracking

Tracking functions are integrated to eliminate abrupt output signal changes at change-over to and from the control modes MAN, Clamp (MAN) and E3.

4.10.3 Output Ramp Functions

The input terminals described below determine the maximum permitted rate of change as follows:

- Speed 4 Output ramp speed. Specified in percent units/second.

4.10.4 Output Limitations

The limiting values Out H and Out L limit the value of the output signal. The output limits are set in the Extended Faceplate on the faceplate element "Limits1".

4.11 Output Signal Control

Output signal control includes the following functions.

- Selection of output signal
- Output signal limitation

4.11.1 Selection of Output Signal

The output signal is selected in accordance with the control mode as follows:

- AUTO, E1, E2 output control signal
- MAN, Clamp (MAN), E3 output control signal

- BAL control signal, the value of balance reference is transferred to the output.

The following input terminals are being used for output control.

FEEDFWD	Feed Forward
BALREF	Balance reference
BALIN	Signal for selection of BALREF
EOHL	Upper external limiting value
EOLL	Lower external limiting value
EOLIM	Signal for selection of external limitation
IB1REF	IB1 reference
IB2REF	IB2 reference
IB1	Signal for selection of IB1REF
IB2	Signal for selection of IB2REF
OUTP	Output signal
OLIMERR	Crossed external limiting value

4.11.2 Output Limiting

The controller output signal is normally limited to Max and Min values of the Real IO signal, connected to the output but limiting values on this signal can be determined either from the operator's station or externally.

The limiting upper and lower values Out H and Out L limit the value of the output signal. The output limits are set in the Extended Faceplate on the faceplate element "Limits1".

The activation of input terminal EOLim determines whether the external limits EOLL and EOHL or internal limits Out H and Out L are applied to the output limitation. The operator-entered limiting values are not affected when external limits are used. The limiting values currently active are presented on the faceplate and object display.

The limiting values from the operator Out H and Out L can be set equal but Out L cannot be set greater than Out H. If the external limiting value EOLL is greater than EOHL then only the upper value EOHL applies. The output signal can thereby be force controlled to the value for EOHL. The crossing of the limiting values causes a fault indication (OLimErr).

4.11.3 Interlocks

The controller can be interlocked by using IB1 and IB2 input terminals. Deactivation of these terminals set the output value to a fixed value, which is present at the IB1Ref and IB2Ref input terminals.

- These interlocks do not change the current control mode, but can be overridden by Manual Forced, when selected by the operator.

- IB1 has higher priority than IB2.
- Both have higher priority than EOLim.
- EOLim, however, can not be overridden by Manual Forced.

4.12 Scaling and Units

The process controller works internally with process-related units up to the calculation of the control deviation where there is a changeover to percentage units. This means that measured values and setpoints, both internal and external are specified in process-related units and other signals in percentage units.

The deviation is expressed in percent of the measured value range (MAX-MIN). The PI-block and the D and output signal have a default range of -100% to +100%. Scaling is possible. The output signal (OUTP) scaling is possible except in the Operator Station bargraph which shows 0 - 100%.

4.13 Alarm and Alarm Limitation Functions

The following alarms are monitored in the function block:

- Measured value MV with two upper and two lower alarm limits
- Control deviation DEV with one upper and one lower alarm limit

When an alarm limit is exceeded, an alarm, which must be acknowledged, is transmitted to the operator station (and printer, if provided). Alarms are also available as outputs on the Function Block.

The time stamping of the alarm is done when the function block is executed.

4.13.1 Alarm Limits

When determining the MV alarm limits, the following equation applies:

$$H\ 2 \geq H\ 1 \geq L\ 1 \geq L\ 2$$

If an attempt is made to cross the alarm limits with each other, the operator is notified that the operation is not permitted. There is no change of the limit.

4.13.2 Alarm Blocking

Supervision of the measured value (MV) and control deviation (DEV) is blocked by activating the input connection ALCBLK.

Automatic alarm blocking can be suitable in connection with start and stop and with anticipated events, the so-called sequential fault blocking. The signal outputs are also affected by this blocking (as to differentiate from operator's blockings which are only blocked on the operator's station and printer).

The event handling function makes it possible to block all alarms from the operator's station or from the function block.

The following errors can be blocked:

$$MV \geq H\ 2$$

$$MV \geq H\ 1$$

$$MV \leq L\ 1$$

$$MV \leq L\ 2$$

$DEV \geq H1$

$DEV \leq L1$

Using Event handling to block alarms means that the printer and operator's station and updating of the error list are blocked. The PC outputs are not affected.

The following terminals are used for alarm handling.

ALCBLK Blocking of alarm on MV and DEV

MV_GT_H2 Measured value exceeds H2

MV_GT_H1 Measured value exceeds H1

MV_LT_L1 Measured value less than L1

MV_LT_L2 Measured value less than L2

DEV_GT_H Deviation exceeds H1

DEV_LT_L Deviation less than L1

SP=HL Setpoint limit, high

SP=LL Setpoint limit, low

OUT=HL Output signal limit, high

OUT=LL Output signal limit low

4.14 Event Handling

Event are generated for status change on the signals defined in interaction window in chapter 4.15.6 Alarm & Event handling.

The layout of the event is described in chapter 5.3 Alarm and Event Handling.

All Operator Events are reported by Audit Trail Functionality and not included in the FunctionBlock.

The individual text string for each event is stored in the Alarm and Event Translator aspect. This text can be NLS handled.

4.15 Interaction Window

The interaction window is available in the Control^{IT} Control Builder. The interaction window is an engineering aid used to simplify configuration and blocking of signals not available on the faceplates. Changes to values in the Interaction window are only available in 'Online' mode in Control^{IT}.

4.15.1 Pid01A Interaction Window

Interaction window overview. Name and description are shown. The buttons are links to sub-windows.

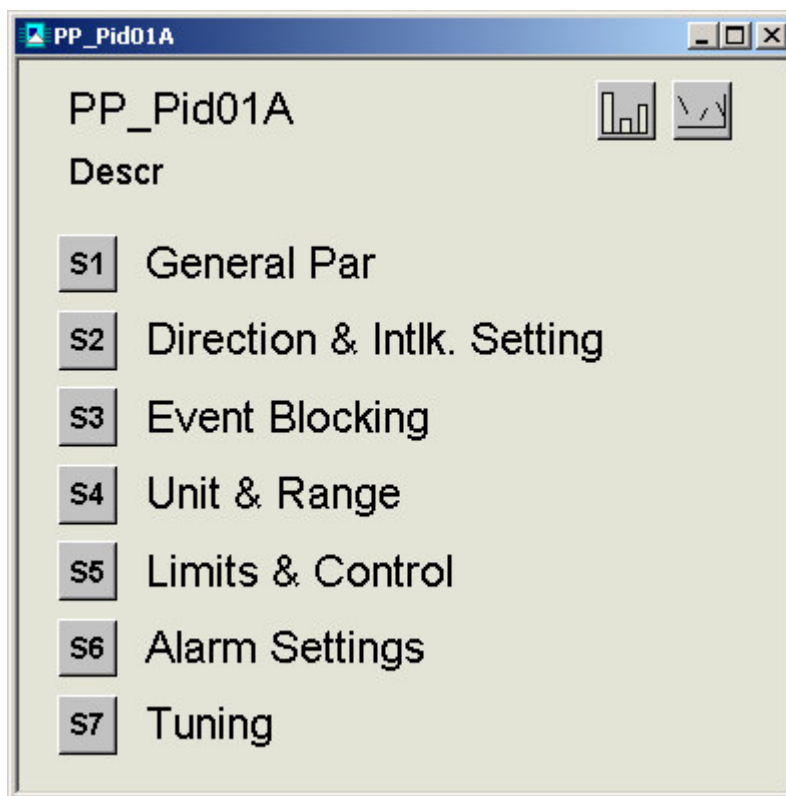

Figure 4-1 Main Interaction Window.

4.15.2 General Parameters

“Class” defines the process section or area in which alarms are grouped. By utilizing class the alarms can be filtered. Valid values are user defined. A suggestion would be to use mill area numbers as class values.

“Severity” defines the alarm priority for general alarms. The severity for MV-alarms is entered in window “Alarm & Event”. Valid values are 1 –1000 where 1000 is the highest priority.

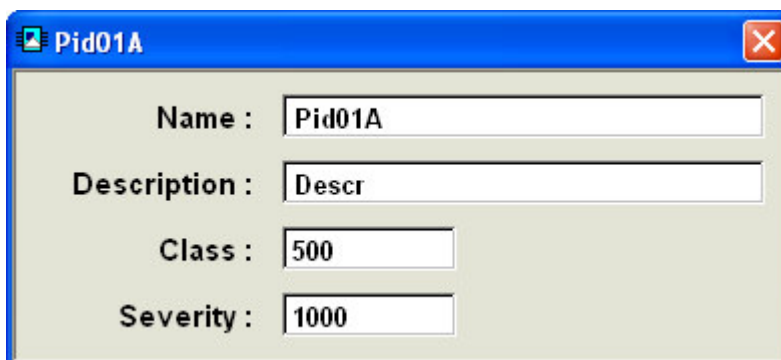

Figure 4-2 General Parameters.

4.15.3 Direction & Intl. Blockings

Control Action (Incr/Incr, Incr/Decr) – indication of direct or reverse control action.

MV Direction (Incr/Decr) – indication of MV response to operator increasing to output.

Actuator Direction (Op/CIs) – indication of actuator response to operator increasing the output.

On/Off Control – indication of actuator feedback in Faceplate and Object Display.

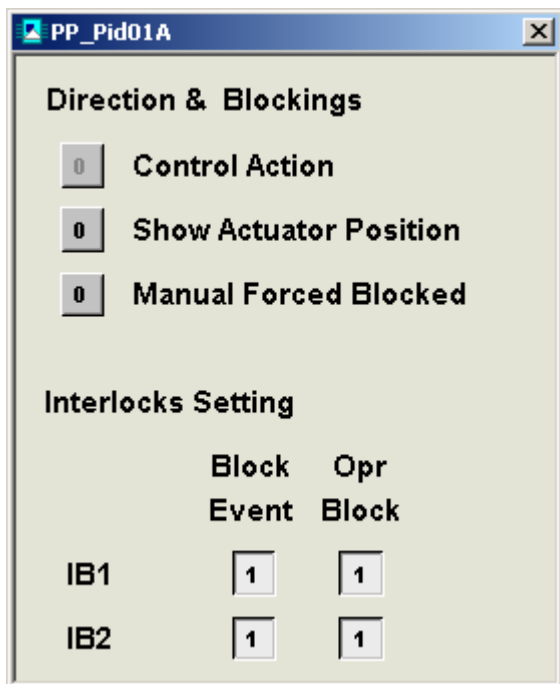

Figure 4-3 Direction & Intl. Blockings.

4.15.4 Units and Range

Measured Value and output (PO), minimum, maximum, units and decimals are entered in this interaction window. The step change for operator increase/decrease buttons is also set in this window.

Pid01A

Units & Range

MV Max : 100.0

MV Min : 0.0

MV Unit : %

MV Decimal : 0

Ratio Max : 100.0

Ratio Min : 0.0

Ratio Unit : %

Ratio Dec : 0

Ratio Inc/Dec : 1.0 %

PO Max : 100.0

PO Min : 0.0

PO Unit : %

PO Decimal : 0

PO Inc/Dec : 2.0 %

Figure 4-4 Units & Range.

4.15.5 Limits & Control

Limits for output signal and possibility to set output and/or setpoint.

Pid01A

Limits & Control

Setpoint High : 100.0

Setpoint Low : 0.0

HSI Out HL : 100.0

HSI Out LL : 0.0

Figure 4-5 Limits & Control.

4.15.6 Alarm & Event handling

Alarm limits, Severity and Enabling of the alarms for measured value and deviation as well as hysteresis and alarm delay time is entered in this window.

For AE config the following values are valid

- 0 No Alarm or Event are generated
- 1 Alarm and Event are generated
- 2 Event is generated

Alarm Settings

1 AE Config AI Err
 0 No Error at Overflow

0 AE Config H2
 MV H2 : 100.0 Severity : 1000

0 AE Config H1
 MV H1 : 100.0 Severity : 1000

0 AE Config L1
 MV L1 : 0.0 Severity : 1000

0 AE Config L2
 MV L2 : 0.0 Severity : 1000

0 AE Config DevH
 Dev H : 100.0

0 AE Config DevL
 Dev L : -100.0

MV Hyst : 2.0

Dev Hyst : 2.0

Alarm Delay : 0d0h0m0s0ms

Figure 4-6 Alarm & Event Handling.

4.15.7 Texts

The different interlock and information texts are entered in the aspect Text Properties. The length of the text is limited to about 60 characters, by the size of presentation element in the Interlock Display.

Name	Value	Type	Description	Readable?	R/Permission	Writable?	W/Permission	Deploy Scheme
IB1	IB1 Interlock Text	String	IB1 Interlock Text	Yes		Yes	Configure	Always Repla
IB2	IB2 Interlock Text	String	IB2 Interlock Text	Yes		Yes	Configure	Always Repla
Bal	Bal Name	String	Bal Name	Yes		Yes	Configure	Always Repla
Clamp	Clamp Name	String	Clamp Name	Yes		Yes	Configure	Always Repla
E1	E1 Name	String	E1 Name	Yes		Yes	Configure	Always Repla
E2	E2 Name	String	E2 Name	Yes		Yes	Configure	Always Repla
E3	E3 Name	String	E3 Name	Yes		Yes	Configure	Always Repla
EOLim	EOLim Name	String	EOLim Name	Yes		Yes	Configure	Always Repla
Info1	Info 1 Text	String	Info 1 Text	Yes		Yes	Configure	Always Repla
Info2	Info 2 Text	String	Info 2 Text	Yes		Yes	Configure	Always Repla

Figure 4-7 Texts.

4.15.8 Parameters

Parameters

Gain :

TI :

TD :

TF :

Beta :

TI Deadb :

Int Block :

Der Block :

Tuning

This is PidCC Interaction Window on top level. Values can not be modified. Sp is the Working Setpoint.

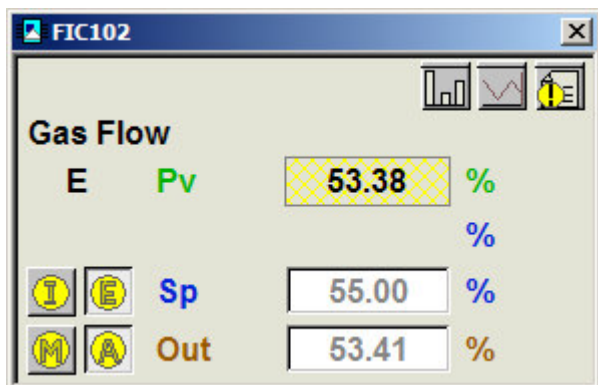

Figure 4-8 PidCC Main Window

4.15.9 Parameters

In this window the control parameters are presented and adjusted.

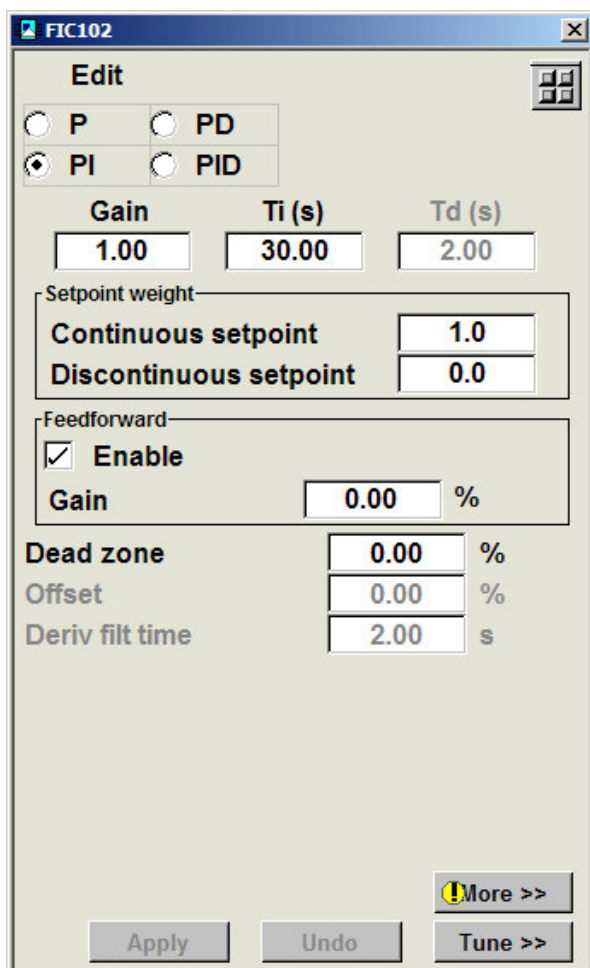

Figure 4.9 PidCC Edit Window

Autotuning is done from this window. Apply will transfer the parameters to the Edit window.

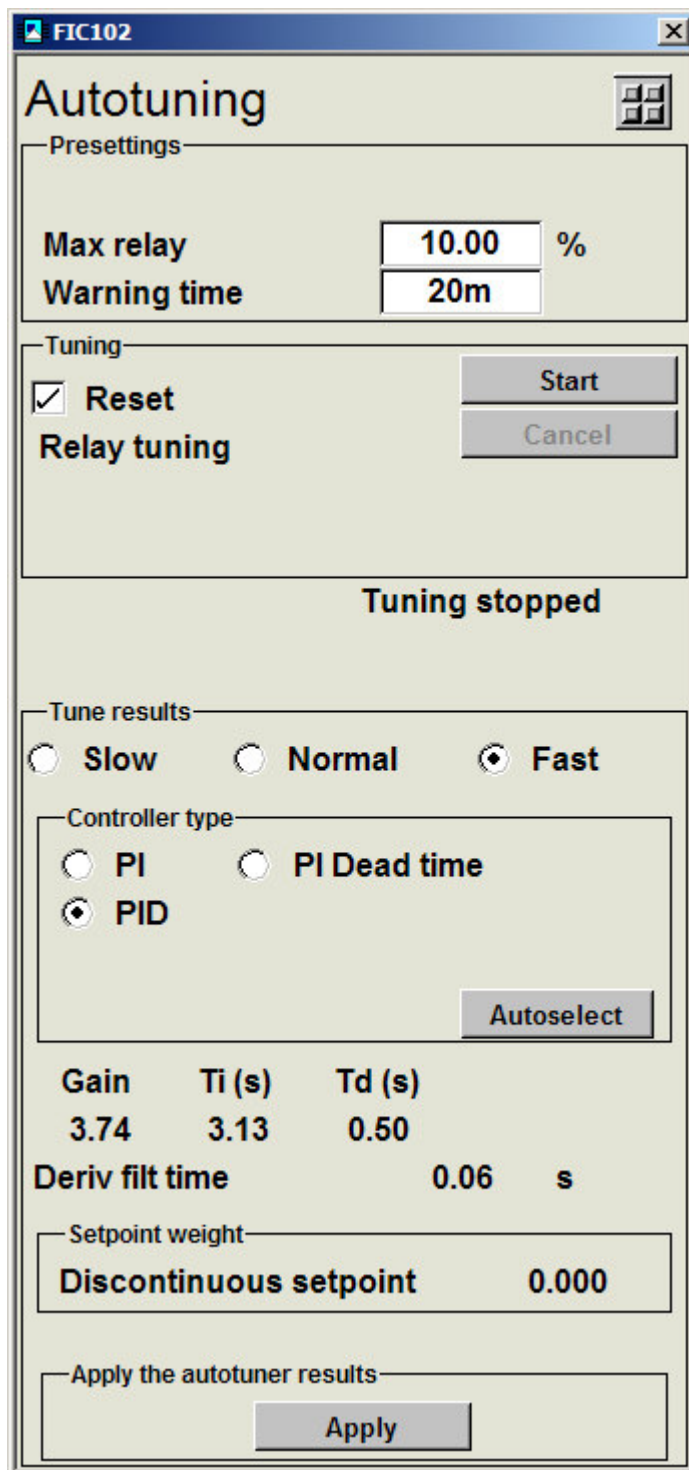

Figure 4-10 PidCC Autotuning Window

This window is for presentation only.

The screenshot shows a software window titled "FIC102" with a close button. The window contains several sections of controls:

- Direction:** Radio buttons for "Direct" and "Reverse". "Reverse" is selected.
- Max sampling time:** A field with a yellow warning icon, set to "0.20 s".
- Sp interaction limits:**
 - Sp max: 100.00 %
 - Sp min: 0.00 %
- Int. setpoint ramping:**
 - Enable int. setpoint ramping
 - Sp incr. rate: 1.00 %/s
 - Sp decr. rate: 1.00 %/s
 - Ramp duration: 0.0 s
 - Disable non-ramped setpoint
 - Backtr. of int. setpoint
 - Enable adj. of offset
- Limit output:**
 - Limit output
 - Out max: 100.00 %
 - Out min: 30.00 %
- Enter range:**
 - Enter range
 - Max: 100.00 %
 - Min: 0.00 %
 - Unit: %
- Out ramp:**
 - Out rate inc: 20.00 %/s
 - Out rate dec: 20.00 %/s
- Deviation alarm:**
 - Pos. level: 10.00 %
 - Enable pos: Pos disabled
 - Pos. level: 10.00 %
 - Enable neg: Neg disabled
 - Start delay: 0.00 s
 - Filter time: 0.00 s
 - Hysteresis: 0.00 %
- Pv fraction:** 2
- Out fraction:** 2

Figure 4-11 PidCC Extra Window

4.15.10 Event Handling

The blocking of Events are entered in this Interaction Window

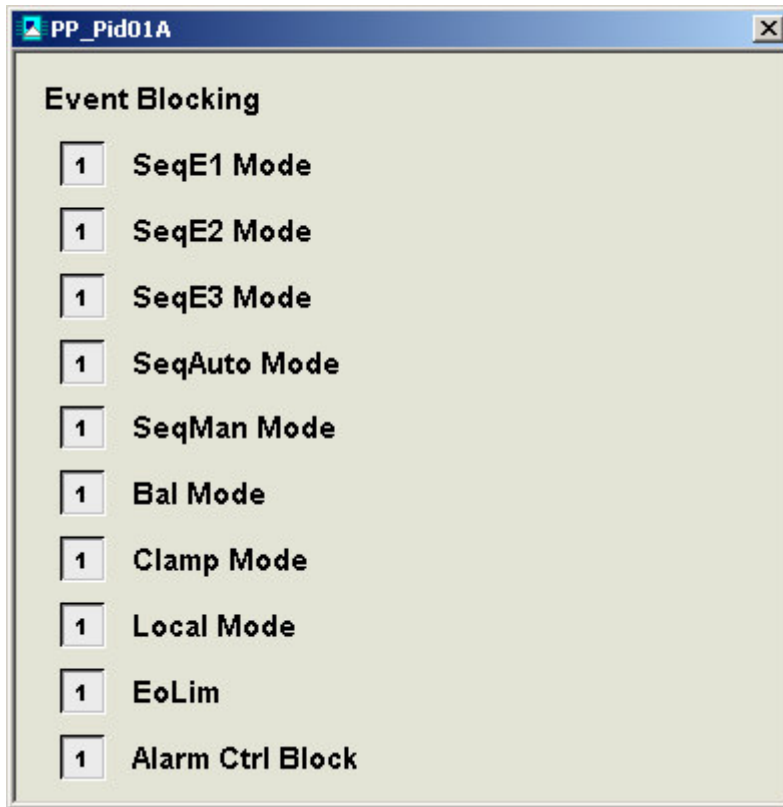

Figure 4-9 Event Blocking.

4.15.11 Gain Scheduling

In this window the control parameters for the different zones are entered.

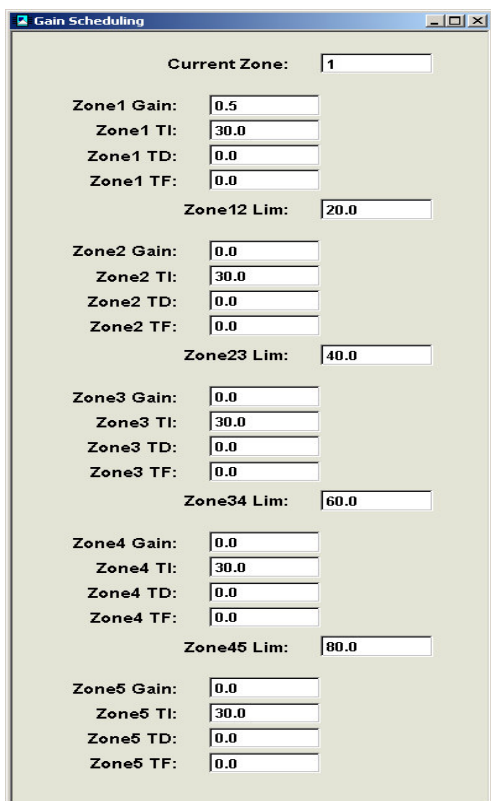

Figure 4-12 Gain Scheduling.

4.15.12 Bargraph

After clicking on the bargraph icon on the main interaction window the following window is displayed, giving an overview of the controllers' values. This is useful if the operator station software is not loaded on the engineering station, together with Control IT.

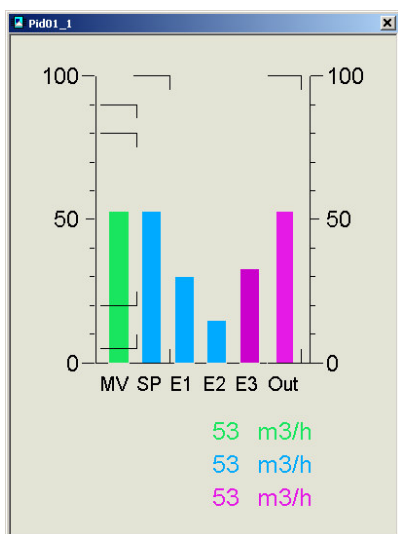

Figure 4-13 Bargraph.

4.15.13 Trend

After clicking on the trend icon on the main interaction window a 2 minute real time trend curve is shown. This is useful for tuning a controller without operator station software.

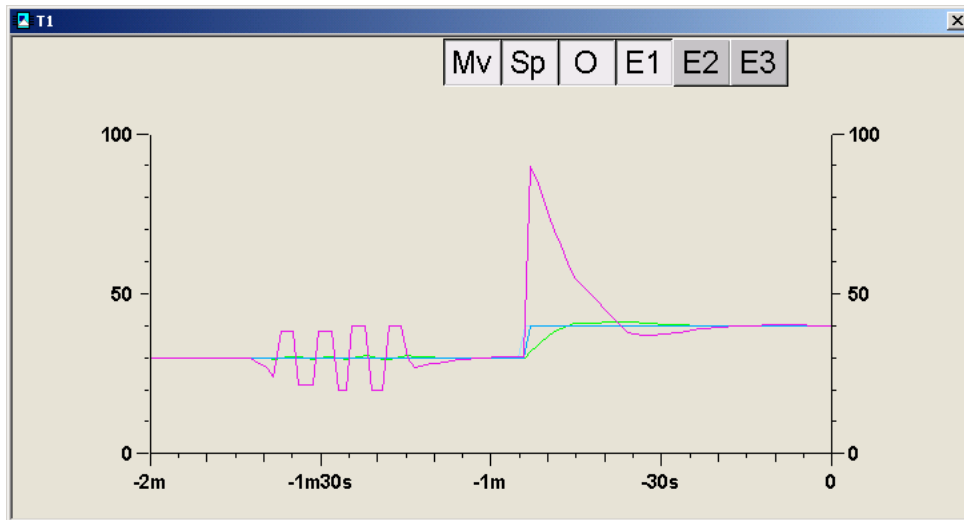

Figure 4-14 Trends.

5 Operator Functions

The Operator functions are divided in principle into 4 parts:

- Presentation (Display elements, Time logged properties)
- Faceplate (Dialog)
- Alarm and Event handling
- Text handling

5.1 Presentation

5.1.1 Display Elements

Display elements, which can be used for different display types, are available for use in the functional unit Pid01A.

The display elements show the status and the controls of the process with different degrees of detail and are intended for the following displays:

- Object display
- Process display
- Interlock display

Examples of different display elements which could be used are given in the following sections.

5.1.1.1 Object Display

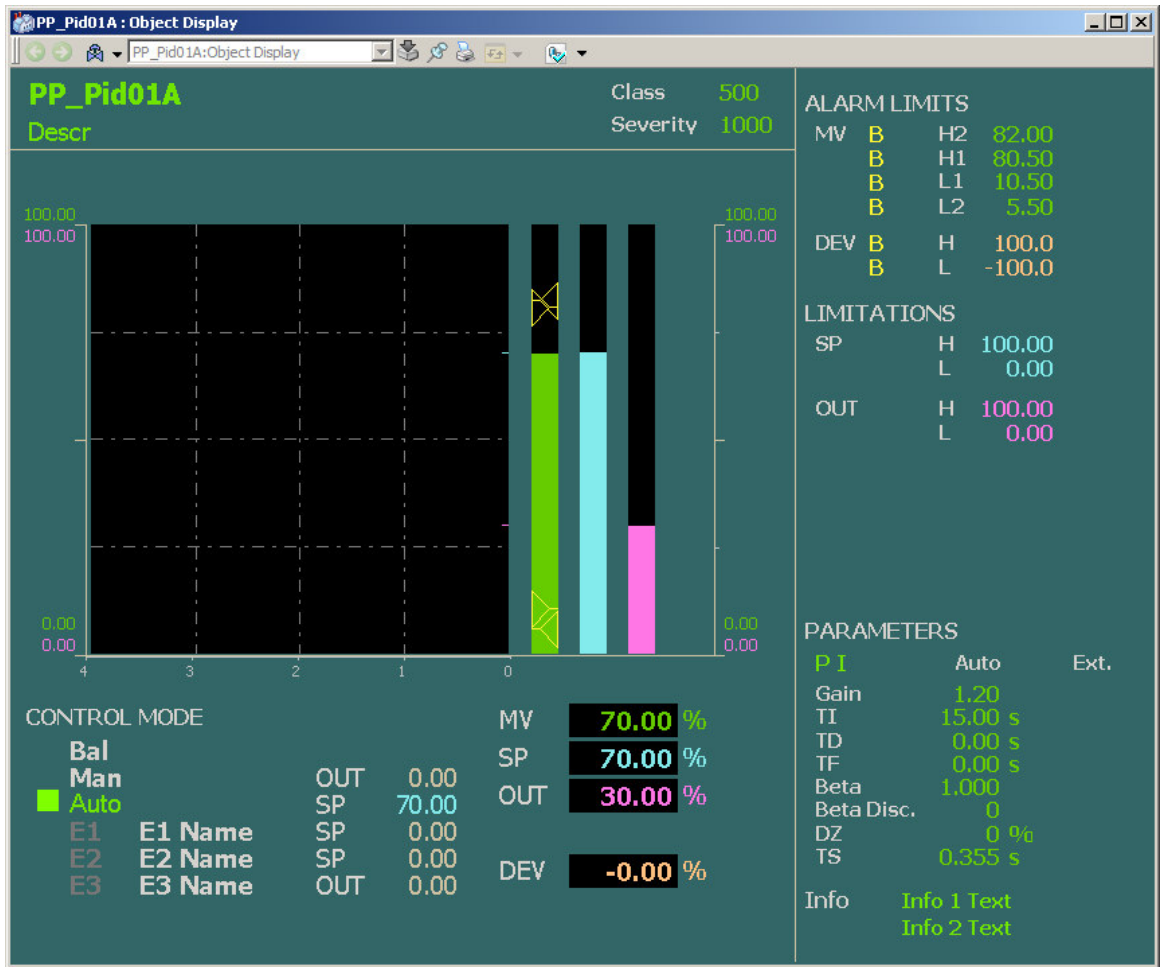

Figure 5-1 Object Display.

5.1.1.2 Process Display

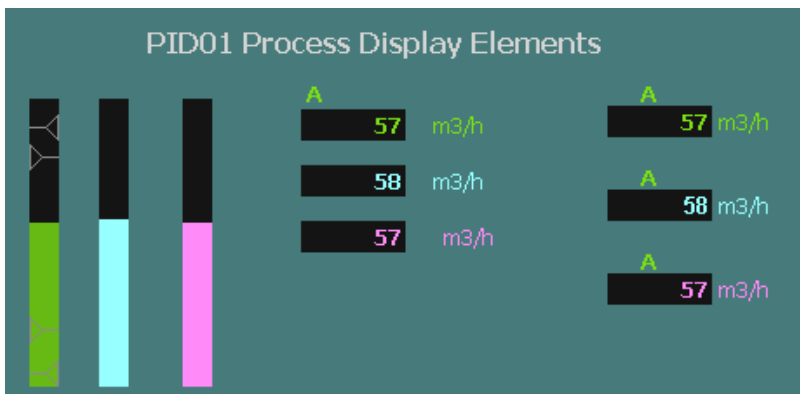

Figure 5-2 Process Display Elements.

5.1.1.3 Interlock display

This display shows the actual status of all Interlock. The operator can override individual interlocks or all interlock.

Interlocks that can be overridden must be set to Blockable. This can be done from this display if the user has permission Configure or from the Interaction Window see chapter 4.15.3.

Start Interlock, Block Event and IA Blocked when no in E1 or E2 mode are parameters that can be set from this display if the user has Permission Configure or from Interaction Window.

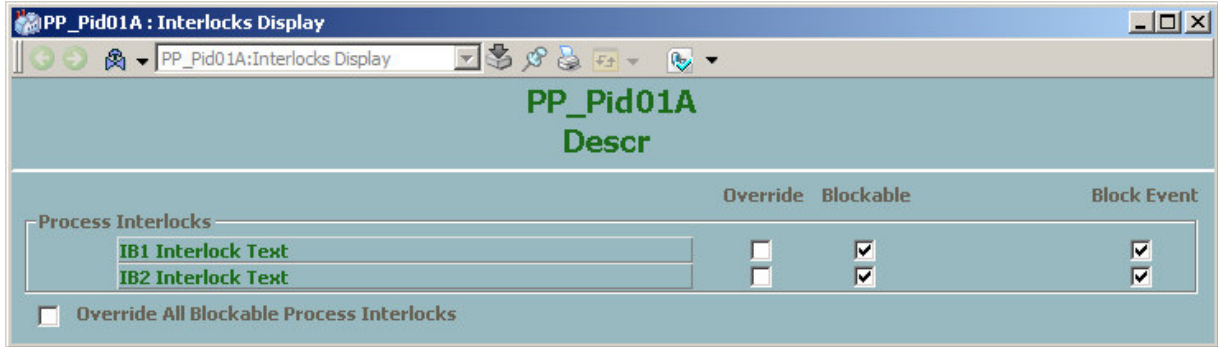

5.1.2 Time-logged Properties

Measured values stored can be presented graphically in the form of curves on the display screen. Such a display, a **Trend display**, can consist of 1- 4 curves. All properties for the object Pid01A are available to be logged on the trend curves.

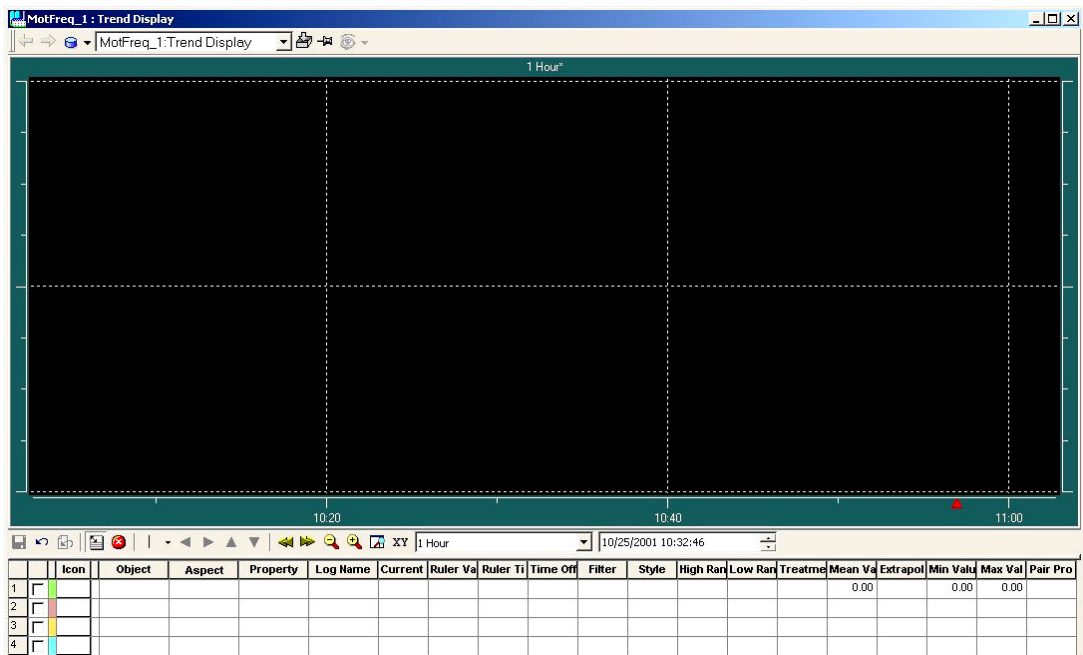

Figure 5-3 Trend Curve

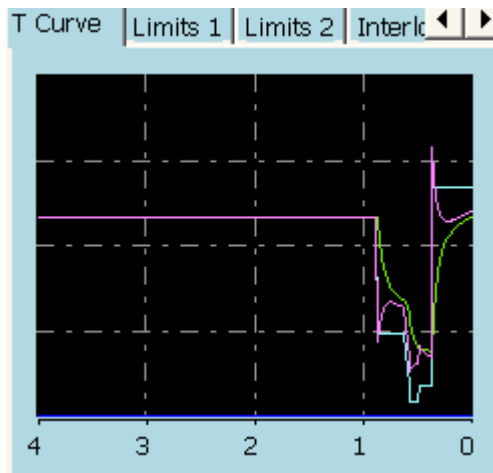

Figure 5-4 Extended Faceplate (T Curve)

5.2 Faceplate(Dialog)

The display screen is supplemented with a mouse and keyboard for operator communication with the functional unit/object.

By using Operate^{IT} Operator Station the operator can view and control the process through faceplates. The dialogue consists of buttons, indicators and graphic presentations within a Faceplate. A faceplate has three levels of dialogue, which are presented by the following three runtime views:

- Reduced Faceplate, where the size and contents typically have been optimized to cover most of the normal process operator actions. Minimum dialogue. This is the default view.
- Faceplate, which typically covers all normal process operator actions. This view is disabled as default.
- Extended Faceplate, with functions and information intended for the process engineer or the advanced operator. Maximum dialogue.

The figures 5-5 to 5-7 below and overleaf illustrate the various presentations of the faceplate.

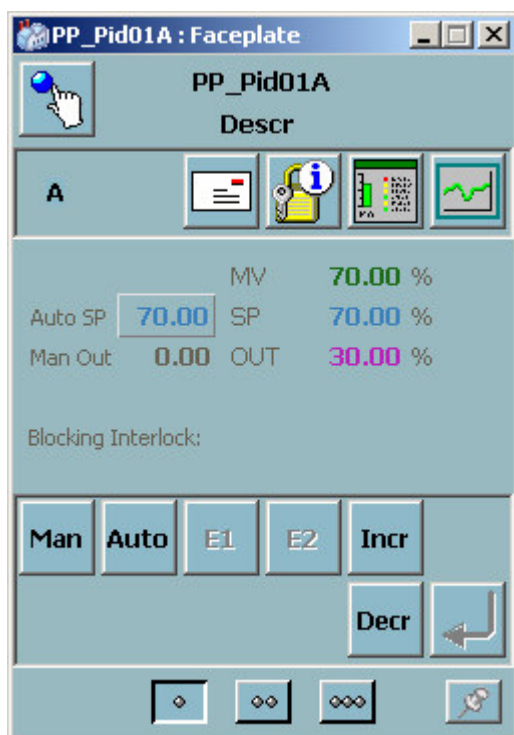

Figure 5-5 Reduced Faceplate.

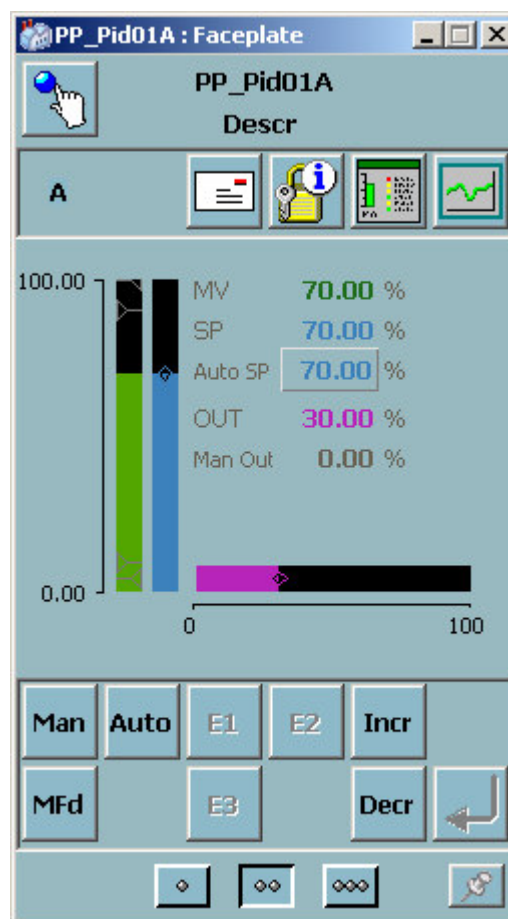

Figure 5-6 Faceplate.

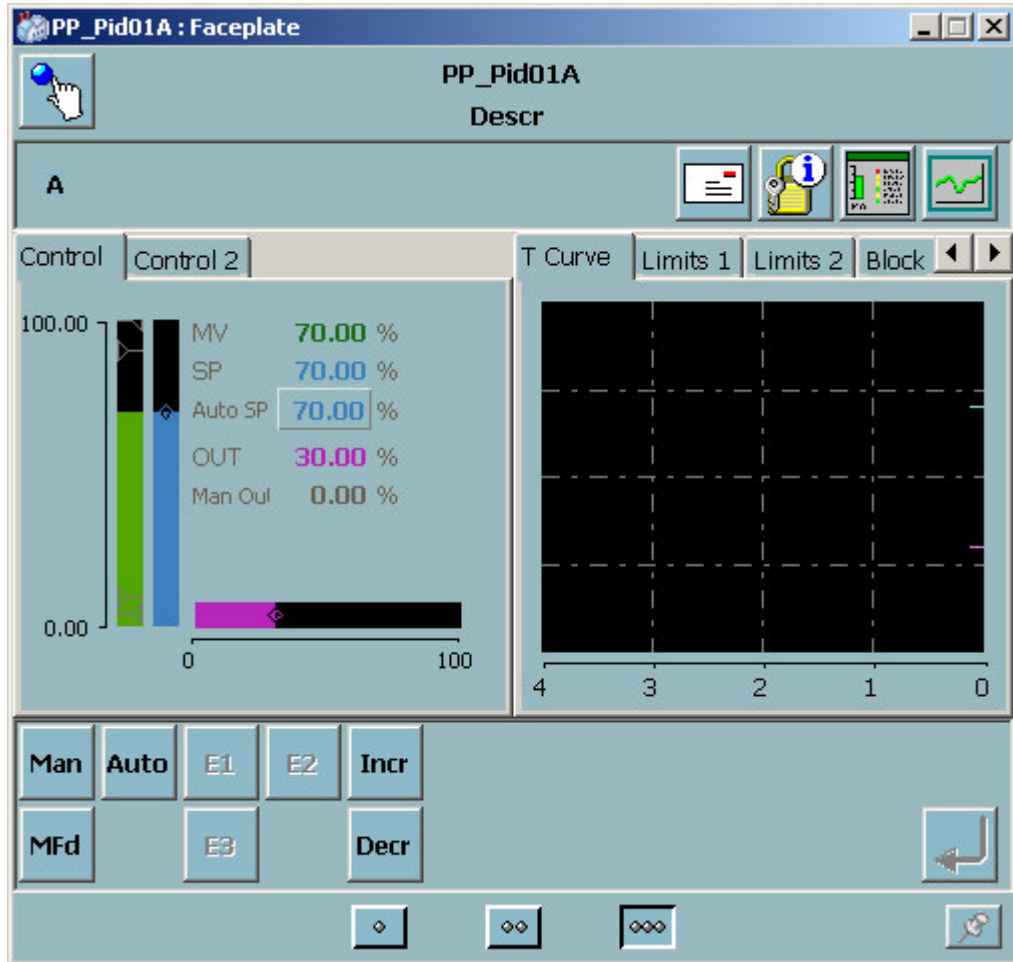

Figure 5-7 Extended Faceplate

5.3 Alarm and Event Handling

5.3.1 General

This section contains a description of all alarms and events in the functional unit Pid01A.

When a measured value deviates from the controllers limits or fails an alarm and an event is generated and can be viewed on the Operate^{IT} Operator Station. The alarms are indicated in the faceplate, object display and in the alarm and event list.

The possibilities of the operator to block alarms are shown under the heading 'Event and alarm blocking' below.

The alarm limits for Pid01A can be controlled individually

Event Time	Object Name	Object Description	Condition	Message Description
02-05-24 03:46:16.763	264M500.RUN	Pulp Mixer Running	Status	Alarm
02-05-24 01:13:04.785	192.168.0.51-0.11.5		HWError	For info see 'Errors and
02-05-24 00:22:18.784	192.168.0.51-0.11.4		HWError	For info see 'Errors and
02-05-23 23:32:31.458	500F1920	Washing Pulp Flow	AI_Err	Alarm
02-05-23 23:32:31.458	500F1920	Washing Pulp Flow	MV_L1	Alarm
02-05-23 23:32:31.458	500F1920	Washing Pulp Flow	MV_L2	Alarm
02-05-23 23:23:01.784	192.168.0.51-0.11.3		HWError	For info see 'Errors and
02-05-23 20:00:07.762	500F1920	Washing Pulp Flow	MV_L2	Alarm
02-05-23 01:38:52.762	500F1920	Washing Pulp Flow	MV_L1	Alarm
02-05-23 00:18:26.995	500F1920	Washing Pulp Flow	AI_Err	Alarm
02-05-22 00:10:00.709	Mot01	Test Mot01	ControlV	Alarm
02-05-20 17:32:45.784	192.168.0.51-0.11.2		HWError	For info see 'Errors and

Figure 5-8 Alarm List

5.3.2 Alarm and Event Message

The following alarm texts are generated by the functional unit Pid01A. The "Condition" text are stored in the Alarm and Event Translator aspect and can be NLS handled.

Object Name	Object Description	Condition	Message Description
<Name>	<Description>	AIError	Alarm
<Name>	<Description>	DevHigh	Alarm
<Name>	<Description>	DevLow	Alarm
<Name>	<Description>	MV > H1	Alarm
<Name>	<Description>	MV > H2	Alarm
<Name>	<Description>	MV < L1	Alarm
<Name>	<Description>	MV < L2	Alarm

The "Message Description" text are stored in the Alarm and Event Translator aspect and can be NLS handled.

SourceName	ObjectDescription	Condition	Message Description
------------	-------------------	-----------	---------------------

<Name>	<Description>		SeqE1 Mode
<Name>	<Description>		SeqE2 Mode
<Name>	<Description>		SeqE3 Mode
<Name>	<Description>		SeqAuto Mode
<Name>	<Description>		SeqMan Mode
<Name>	<Description>		Bal Mode On
<Name>	<Description>		Bal Mode Off
<Name>	<Description>		Clamp Mode On
<Name>	<Description>		Clamp Mode Off
<Name>	<Description>		Local Mode On
<Name>	<Description>		Local Mode Off
<Name>	<Description>		EoLim On
<Name>	<Description>		EoLim Off
<Name>	<Description>		IB1 On
<Name>	<Description>		IB1 Off
<Name>	<Description>		IB2 On
<Name>	<Description>		IB2 Off
<Name>	<Description>		Alarm Acknowledge
<Name>	<Description>		Alarm P Blk

5.4 Faceplate tabs

5.4.1 Alarm Blocking.

By using the extended faceplate it is possible for the process engineer to block alarms.

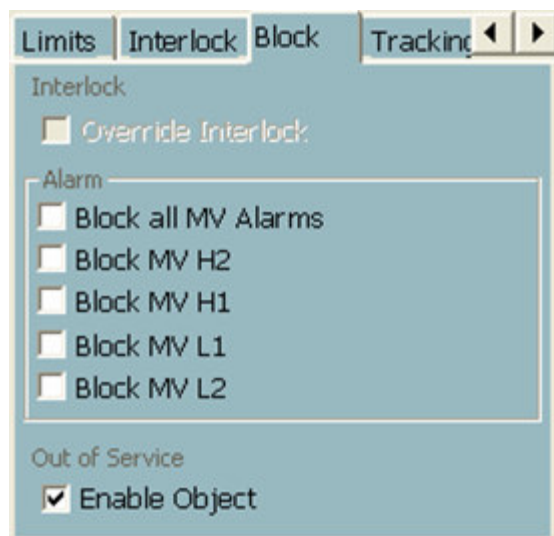

Figure 5-9 Extended Faceplate (Block1)

5.4.2 Limits

By using the extended faceplate it is possible to adjust the limits for the measured value, the setpoint, the deviation and the output. The faceplate elements in the extended faceplate below illustrate this.

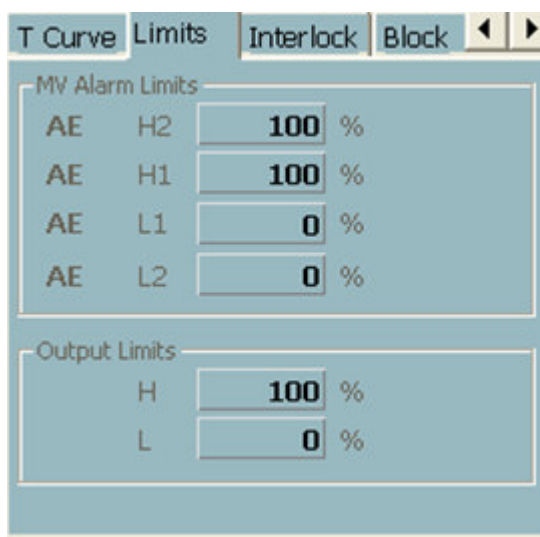

Figure 5-10 Extended Faceplate (Limits1)

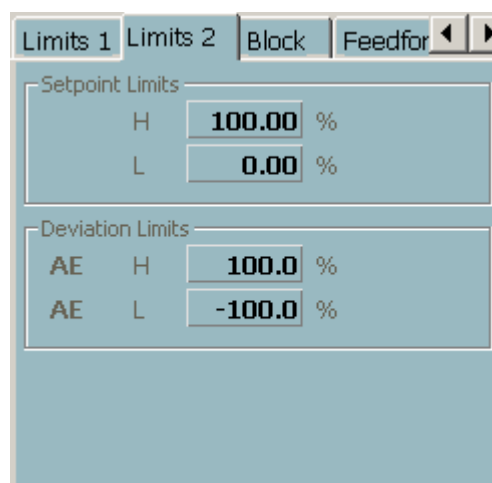

Figure 5-11 Extended Faceplate (Limits2)

5.4.3 Controller Parameters

The "Param" faceplate element in the extended faceplate below illustrates where it is possible to adjust the gain, integral time, derivation time and filter time for the controller. The scan time, control action and controller type is also indicated here.

The feed forward gain is used to compensate for measurable disturbances to achieve faster and smoother control of a process.

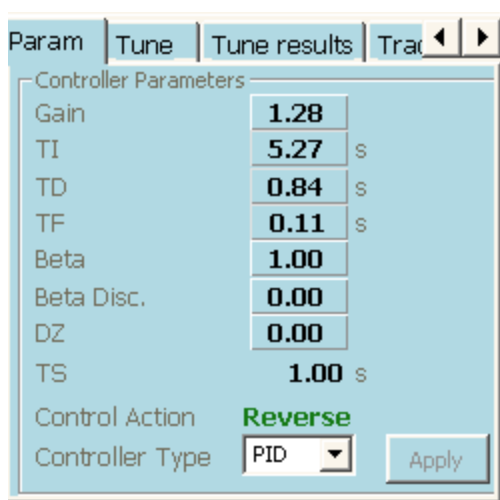

Figure 5-12 Extended Faceplate (Param)

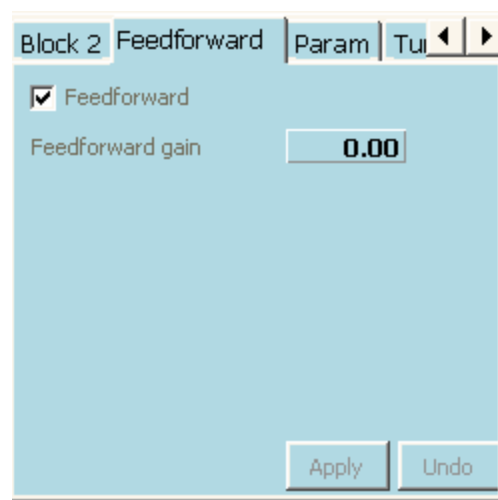

Figure 5-13 Extended Faceplate (Feed Forward)

5.4.4 Autotuning

Two faceplate elements deals with Autotuning:

- Tune is where the tuning is started from
- Tune Result is where the resulting parameters are presented

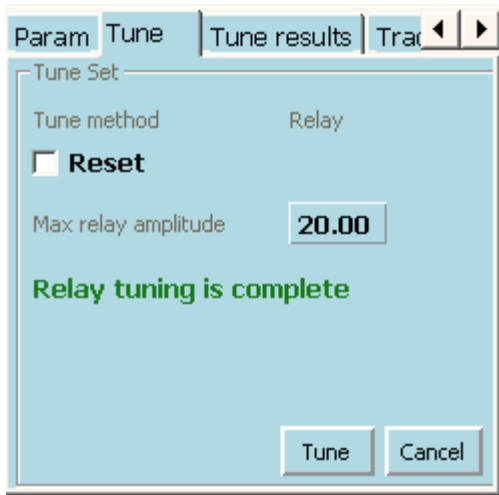

Figure 5-14 Extended Faceplate (Tune)

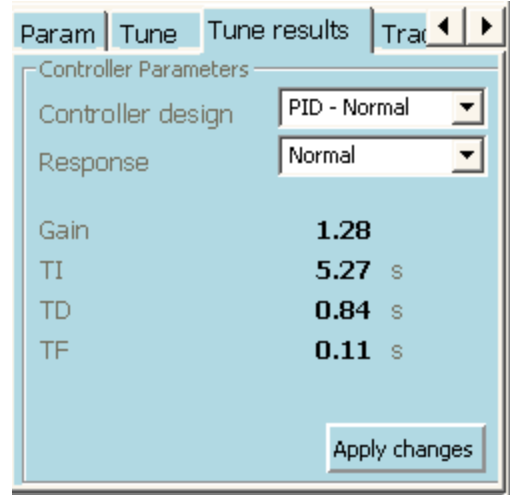
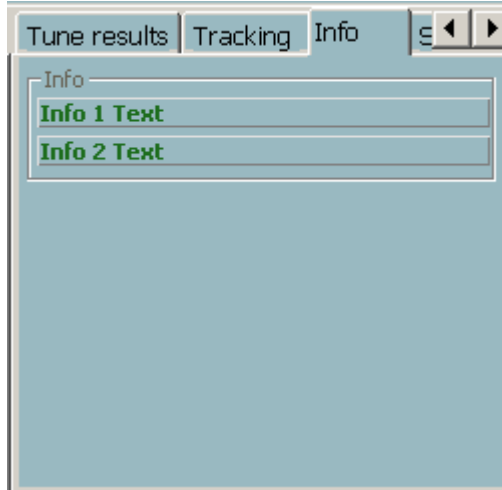

Figure 5-15 Extended Faceplate (Tune Result)

5.4.5 Info Text



5.4.6 Tracking

Tracking setup is presented in text.

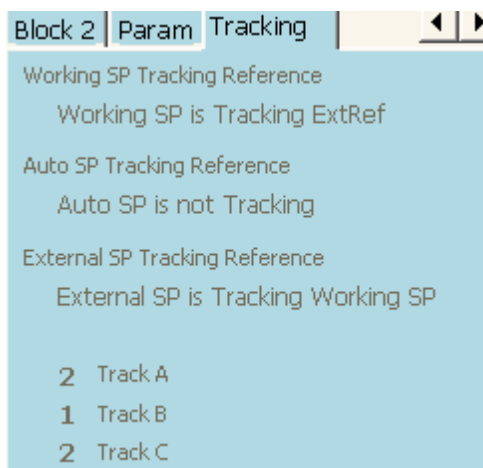

Figure 5-17 Extended Faceplate (Tracking)

5.4.7 Status IO

The “Status” tab is showing the type of device and it’s status for the measured value. If the signal is connected via a Profibus PA link the extended status from the device is showed in this tab. For more information see document *Integration of PA instruments 3AST001 792 D0090*.

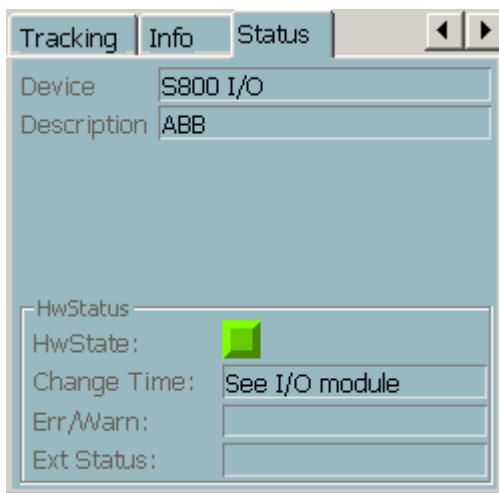

Figure 5-17 Extended Faceplate (Status IO)

6 References

Ref1.:

3BSE 028 809 R101 Rev B Control^{IT} AC 800M/C Version 3.2 Analog Process Control
Objects and Design

REVISION

Rev.	Page (P) Chapt. (C)	Description	Date Dept./Init.
-		New document	2005-02-22/HE
A	4, 5	Interaction Window & Faceplate. Rev 4.0/1	050902/MP
B	3	Param connection removed rev 4.0/5	070511/BP
C	4.2.5	External control data updated	080623/BP
D		5.0-1 Interlock functionality updated	081203/BP