



PRODUCT PRESENTATION EPMV PG APPARATUS, 2017

NALFWind for wind&solar farms

Indoor switches technology

Tomasz Komalski, GPMM EPMV

Agenda

Indoor air insulated NALFWind switch-fuse combination

Scope

Introduction

Wind tower connection to grid - medium voltage component design

Portfolio

CSS Application

Summary – Customer benefits

NALFWind for wind&solar farms

Introduction

Windfarm challenges

The worldwide demand for renewable energy is growing constantly, with wind power as one of the fastest growing sectors. To meet the current and future needs of network operators, manufacturers and designers of wind power systems need to be able to call on both advanced technologies and in-depth knowledge.

More and more demanding expectations to reduce cost of generated energy have required both design and performance optimization of wind farms, especially considering available alternative renewables energy sources (solar, biomass, biogas, hydro etc.).

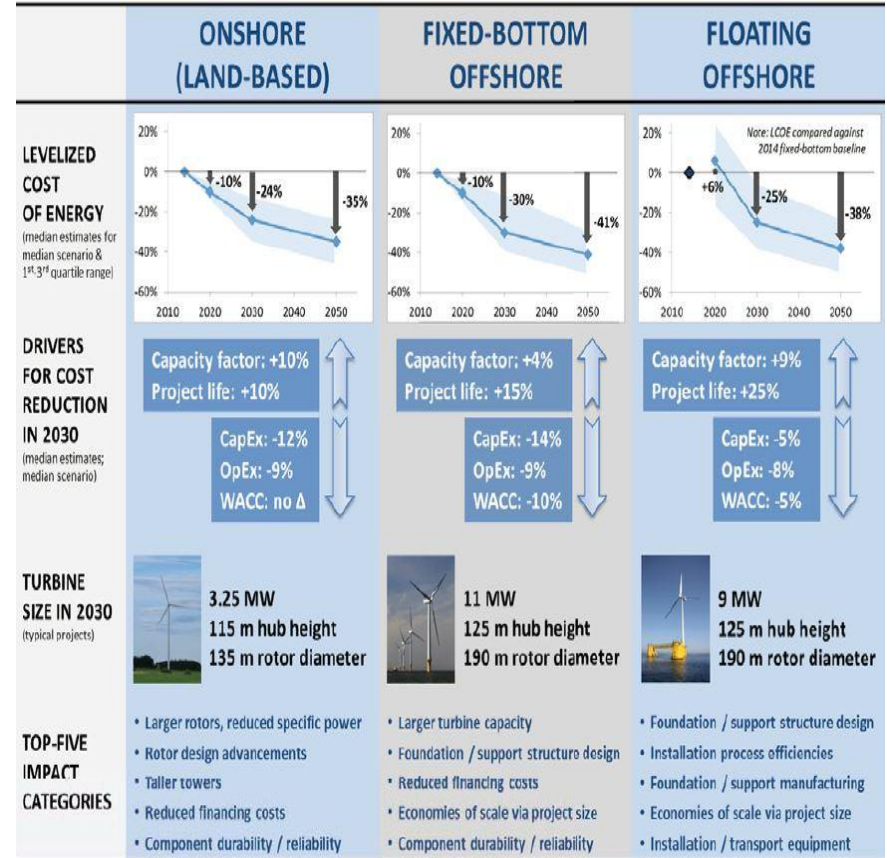

NALFWind for wind&solar farms

Introduction

Grid connection schemes

The electrical installation in the area of connection between wind tower and the grid needs to be optimized;

- The process considers both connecting lines (cables, overhead lines) switching&protection equipment and transformers;
- The cost efficient scheme require balance between functionality and performance;

All these is achievable today!

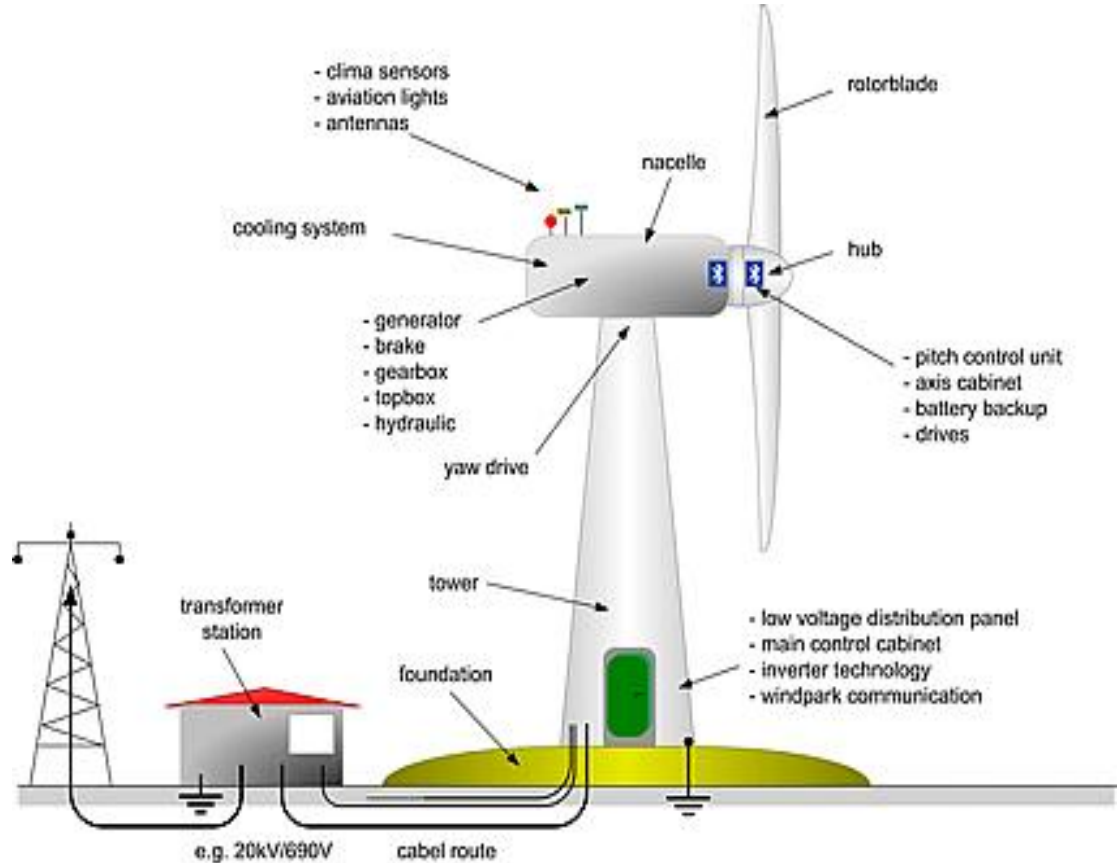

NALFWind for wind&solar farms

Wind farm typical application concepts for MV installations

Nacelle design principles

Transformer inside wind tower

- Nacelle with gear box - generator voltage is increased by transformer, transferred by HV cable down to further connecting points

Transformer outside wind tower

- Generator voltage 0.69 kV is transferred down by LV cable that are coming to transformer substation outdoor or indoor one

Applicable inside nacelle without transformers

Figure 2.3 Inside a Typical Wind Turbine Nacelle

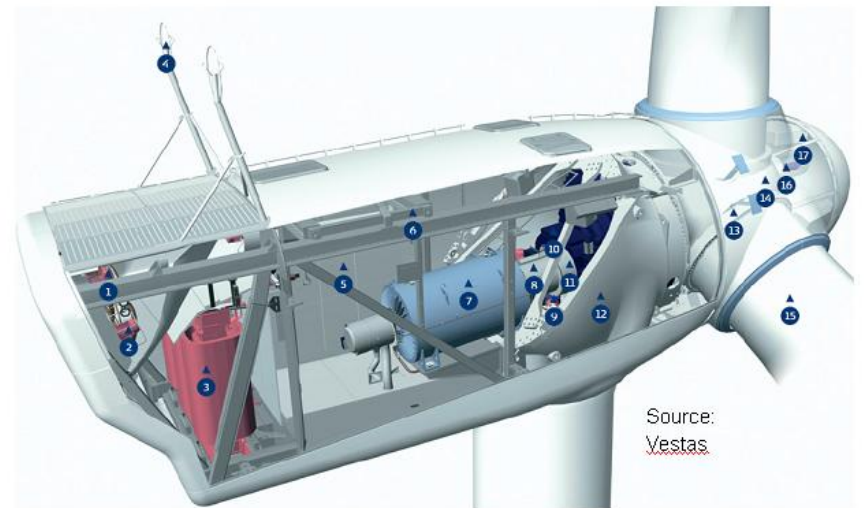

- | | | | |
|-------------------------------------|---------------------------|--------------------------|-------------------|
| 1 Oil cooler | 6 Service crane | 11 Mechanical disc brake | 16 Pitch cylinder |
| 2 Water cooler for generator | 7 OptiSpeed® generator | 12 Machine foundation | 17 Hub controller |
| 3 High voltage transformer | 8 Composite disc coupling | 13 Blade bearing | |
| 4 Ultrasonic wind sensors | 9 Yaw gears | 14 Blade hub | |
| 5 VMP-Top controller with converter | 10 Gearbox | 15 Blade | |

NALFWind for wind&solar farms

Wind farm typical application concepts for MV installations

Nacelle design principles

Transformer inside wind tower

- Nacelle with gear box - generator voltage is increased by transformer, transferred by HV cable down to further connecting points

Transformer outside wind tower

- Generator voltage 0.69 kV is transferred down by LV cable that are coming to transformer substation outdoor or indoor one

Applicable inside nacelle without transformers

Technical specifications

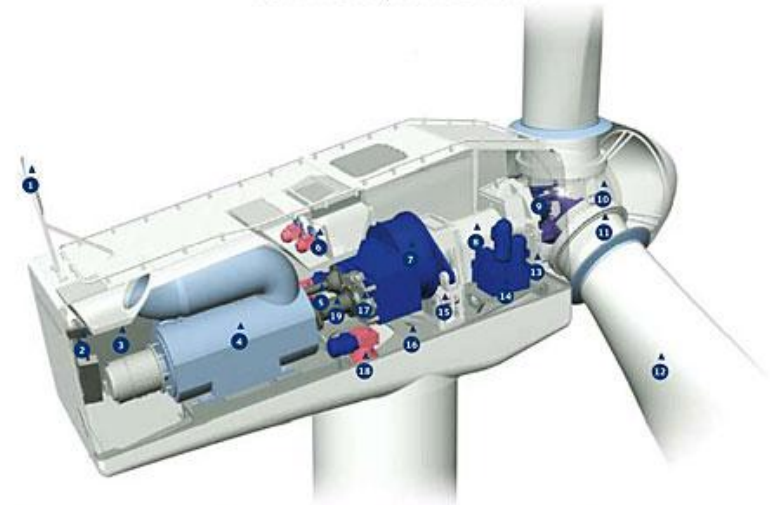

- | | | | |
|-------------------------------------|-------------------------|-----------------------|----------------------------|
| 1 Ultrasonic wind sensor | 6 Oil and water coolers | 11 Blade bearing | 16 Mechanical disc brake |
| 2 Service crane | 7 Gearbox | 12 Blade | 17 Yaw gear |
| 3 VMP-Top controller with converter | 8 Main shaft | 13 Rotor lock system | |
| 4 OptiSpeed* Generator | 9 Pitch system | 14 Hydraulic unit | 15 Composite disc coupling |
| 5 Pitch cylinder | 10 Blade hub | 18 Torque arm | |
| | | 19 Machine foundation | |

NALFWind for wind&solar farms

Wind farm typical application concepts for MV installations

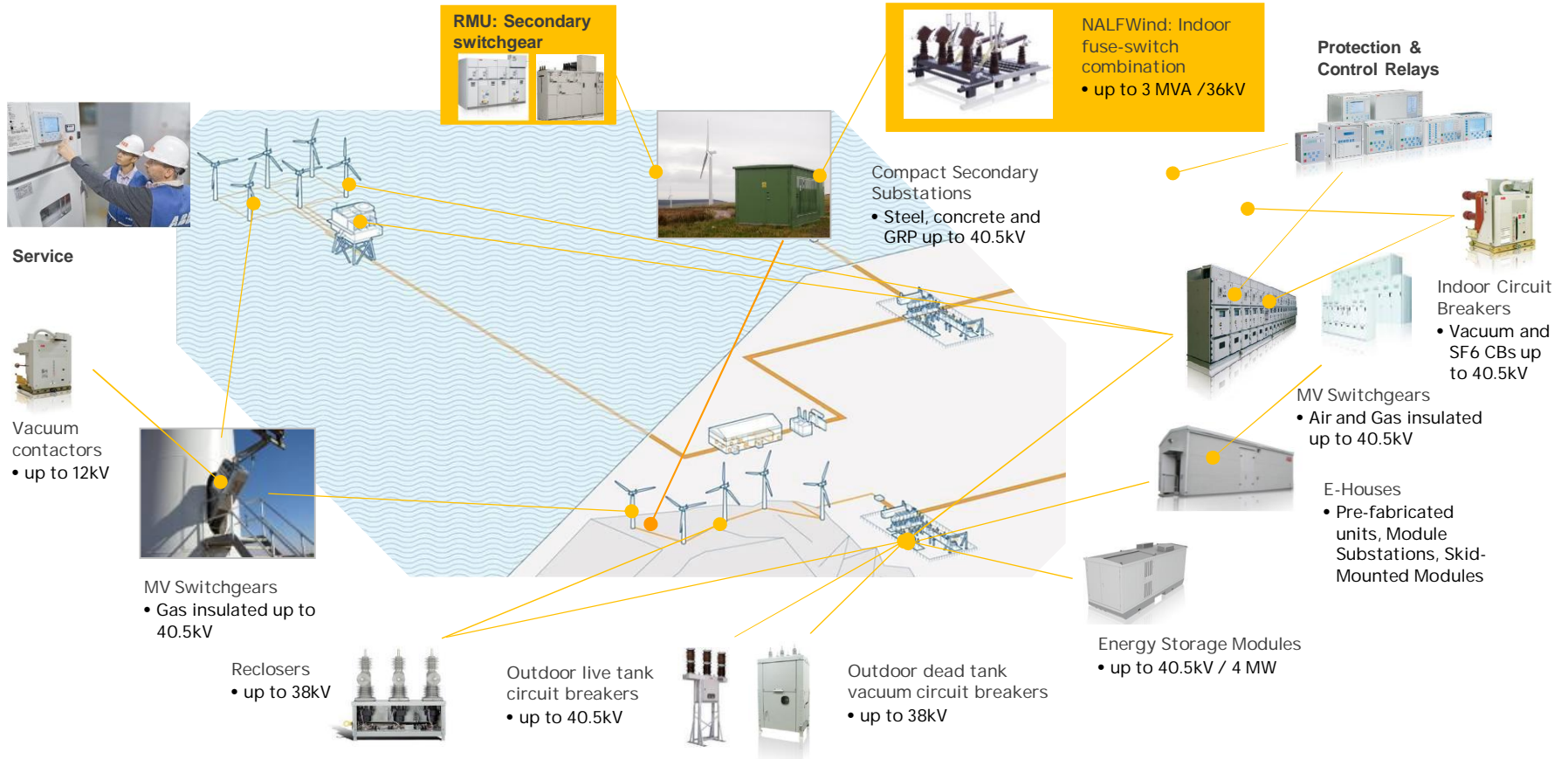

NALFWind for wind&solar farms

Technology comparison

Switch-fuse combination open air

Features

- Electrical&mechanical performance level M1/E1 according to IEC
- High capability for transformer protection by current limiting fuses up to 3000kVA
- Visible insulation gap
- Easy access to all breaking components
- Limited maintenance
- Possibility to use inside/outside wind towers (inside in big nacelle only)

RMU switch-fuse combination

Features

- Electrical&mechanical performance level M1/E1 according to IEC
- Capability of transformer protection by fuses up to 1600 kVA
- Mechanical switch position indicator
- Breaking components placed inside closed tank
- Maintenance free
- Possibility to use inside and outside wind towers (including installation thru narrow door gate)

ABB offers best solutions for wind/solar installations

NALFWind for wind&solar farms

Technology comparison

SD vs. CB

Both switch-fuse combination and circuit breaker offers similar functionality for switching and protection of transformers.

The circuit breaker pros is higher breaking performance

The switch-fuse combination pros is optimized cost with required performance

Investment costs in more detail. Original layout

Component	Cable	ma
Fundament [22]		
Turbine [16]		
Breaker [17]		
Disconnect switch [
Sea cables [28]	3x95 3x185 3x240 3x400	
Land cable [28]	3*(1x64	
Transformer [33]		
Platform [17]		
		Total cost [MSEK] 1603

- Protection by breaker require:
- § Breaker
 - § Relay
 - § CT
 - § Disconnect or withdrawable breaker
 - § Earthing switch (optional)

- Protection by switch-fuse combination require:
- § Switch-fuse combination with current limiting fuses
 - § Earthing switch (optional)

NALFWind for wind&solar farms

NALFWind design principles

Modular design for easy adaptation inside compact transformer stations

The NALFWind is 36 kV air-insulated switch-fuse combination with short circuit breaking current 31,5 kA (with CEF-S 63 A fuses)

- Main configurable components
 - Fuse base with fuse tripping system and blown fuse indicator – protection up to 3000 kVA at 36 kV with CEF-S 30/40.5 kV 63 A fast acting fuses
 - Earthing switch with making capacity of 79 kA (peak with CEF-S 63 A fuses)
 - Auxiliary contacts for switch and earthing switch
 - Motor drives – shaft and front mounted
 - Mechanical/electrical interlocks



NALFWind for wind&solar farms

CSS application concept

NALFWind in CSS

Proposal for ABB CSS Mercure family CSS with NALFWind 36 kV switch-fuse combination with upper fuse base and CEF-S 30/40.5 kV fast acting current limiting fuses.

– Optional equipment:

- Earthing switch with making capacity.
- Passive voltage indicators type VV-B

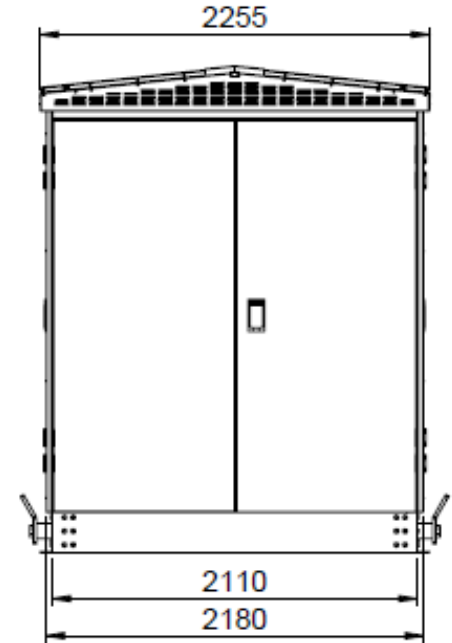
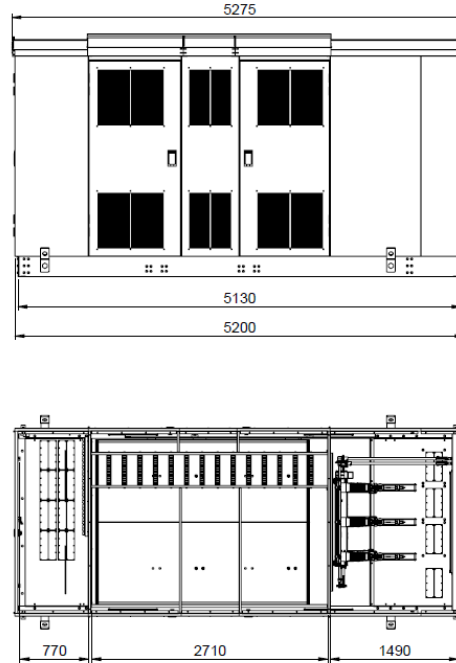

NALFWind for wind&solar farms

CSS application concept

NALFWind in CSS

NALFWind configuration for arrangement inside substation with optimized connection with transformer.

– Highlights:

- HV transformer terminals should be connected to HV fuse base;
- Earthing switch should be available at fuse base side
- Switch arcing chamber should be position down to ground

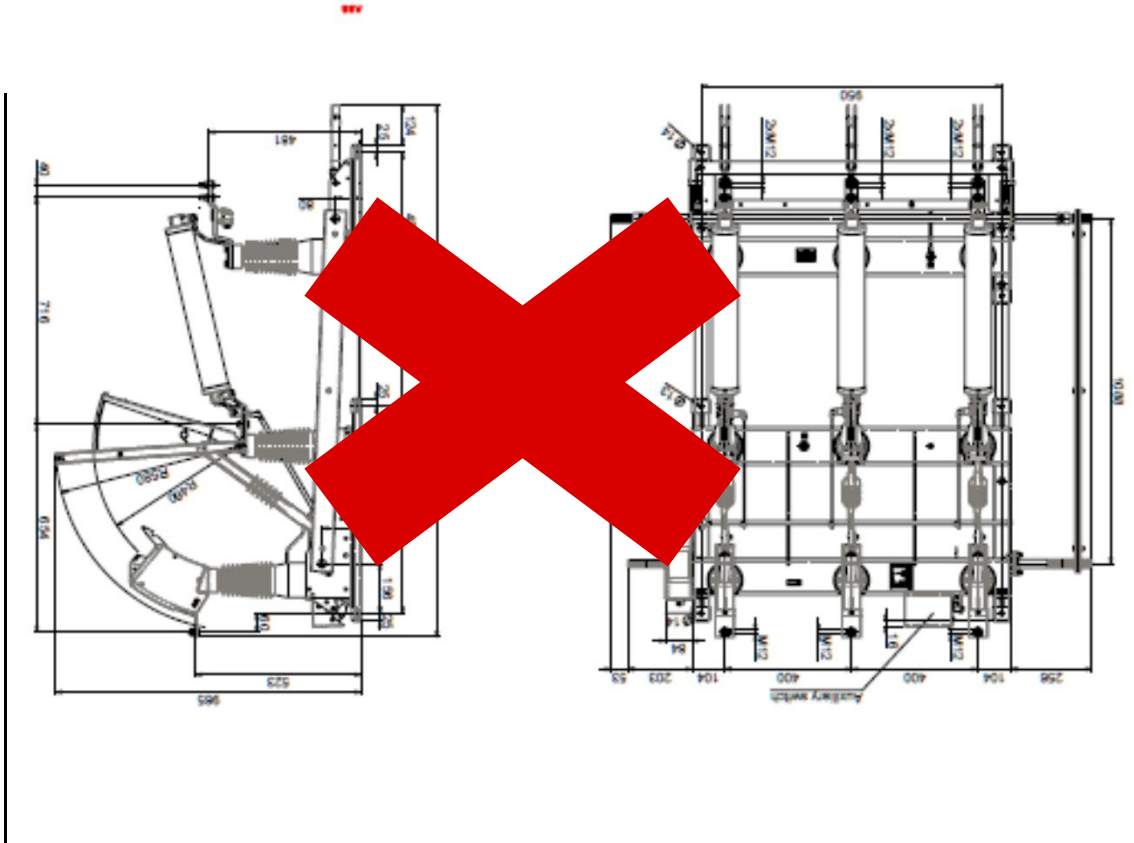

NALFWind for wind&solar farms

CSS application concept

NALFWind in CSS

NALFWind configuration for arrangement inside substation with optimized connection with transformer.

– Highlights:

- HV transformer terminals should be connected to HV fuse base;
- Earthing switch should be available at fuse base side
- Switch arcing chamber should be position down to ground

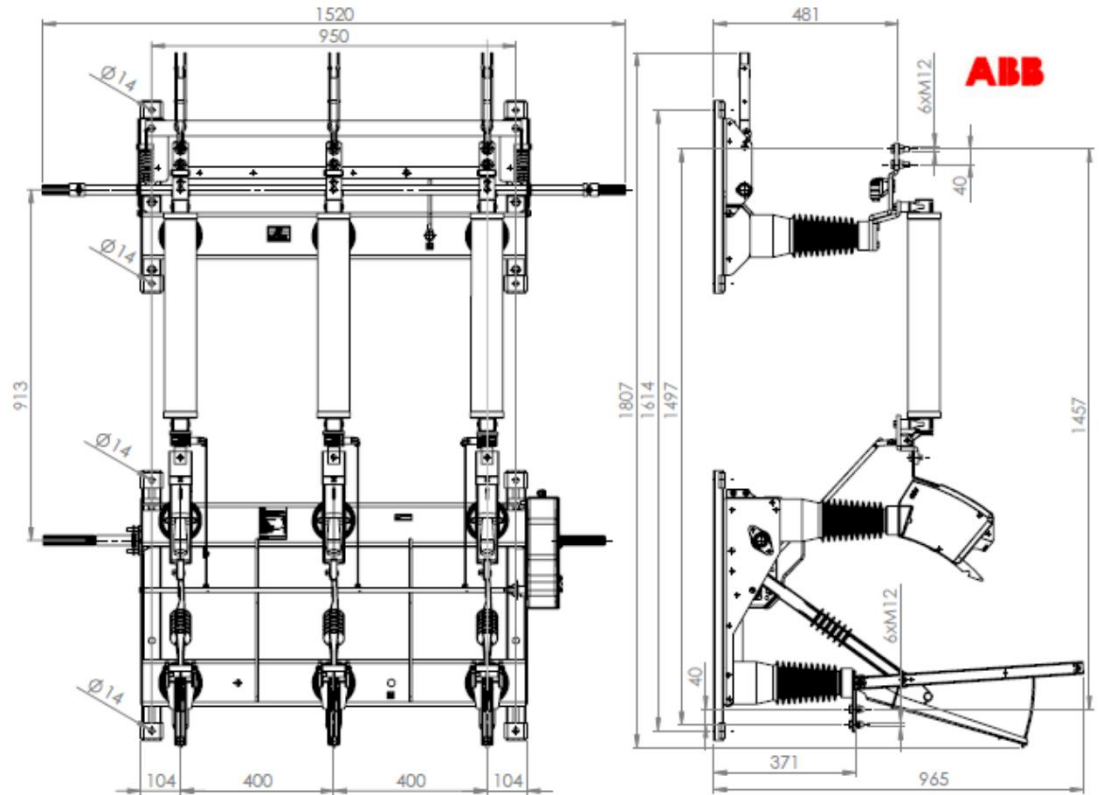

NALFWind for wind&solar farms

CSS application concept

NALFWind in CSS

ABB's NALFWind 36 kV switch-fuse combination units has been incorporated into 163 units of transformer/network protection substations in De Aar South African 138 MW Wind Farm project as the most cost-efficient solution

The NALFWind and NAL were delivered to many wind projects world wide (UK, Brazil, Sweden, South Africa)

The NALFWind product name and design principles have been TM protected

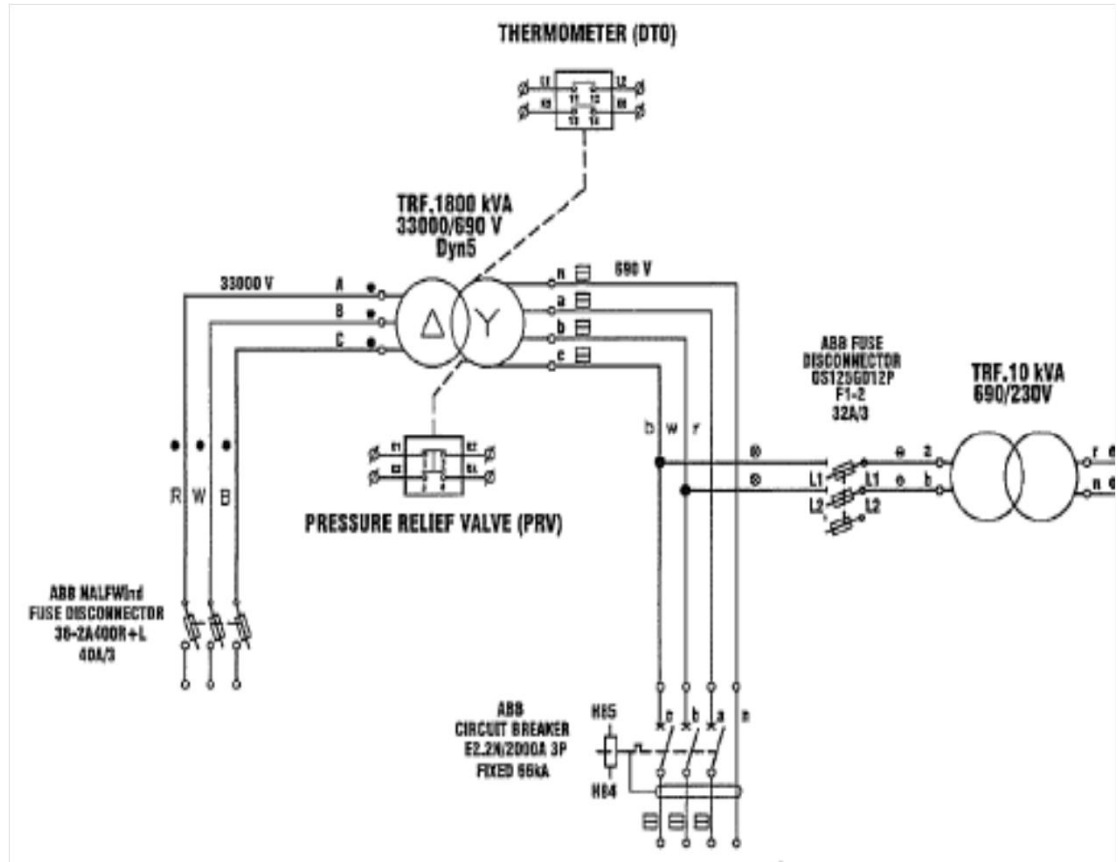

NALFWind for wind&solar farms

CSS application concept

NALFWind in CSS

ABB's NALFWind 36 kV switch-fuse combination units has been incorporated into 163 units of transformer/network protection substations in De Aar South African 138 MW Wind Farm project as the most cost-efficient solution

The NALFWind and NAL were delivered to many wind projects world wide (UK, Brazil, Sweden, South Africa)

The NALFWind product name and design principles have been TM protected

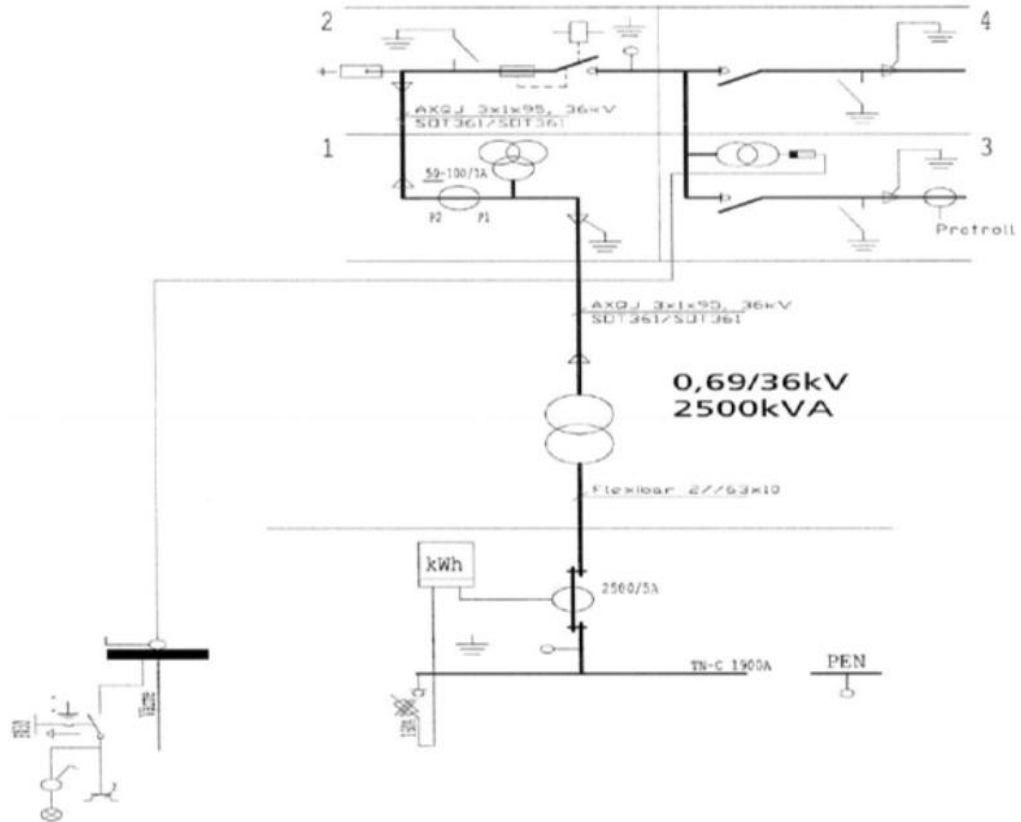

NALFWind for wind&solar farms

CSS application highlights

NALFWind in CSS

Fast interruption time

- Very fast clearance of short circuit currents due to use of fast acting CEF-S current limiting fuses that operates within few ms vs over 90 ms available for CB with protection relay and CT
- Full range protection for overload currents based on IEC 62271-105 principles

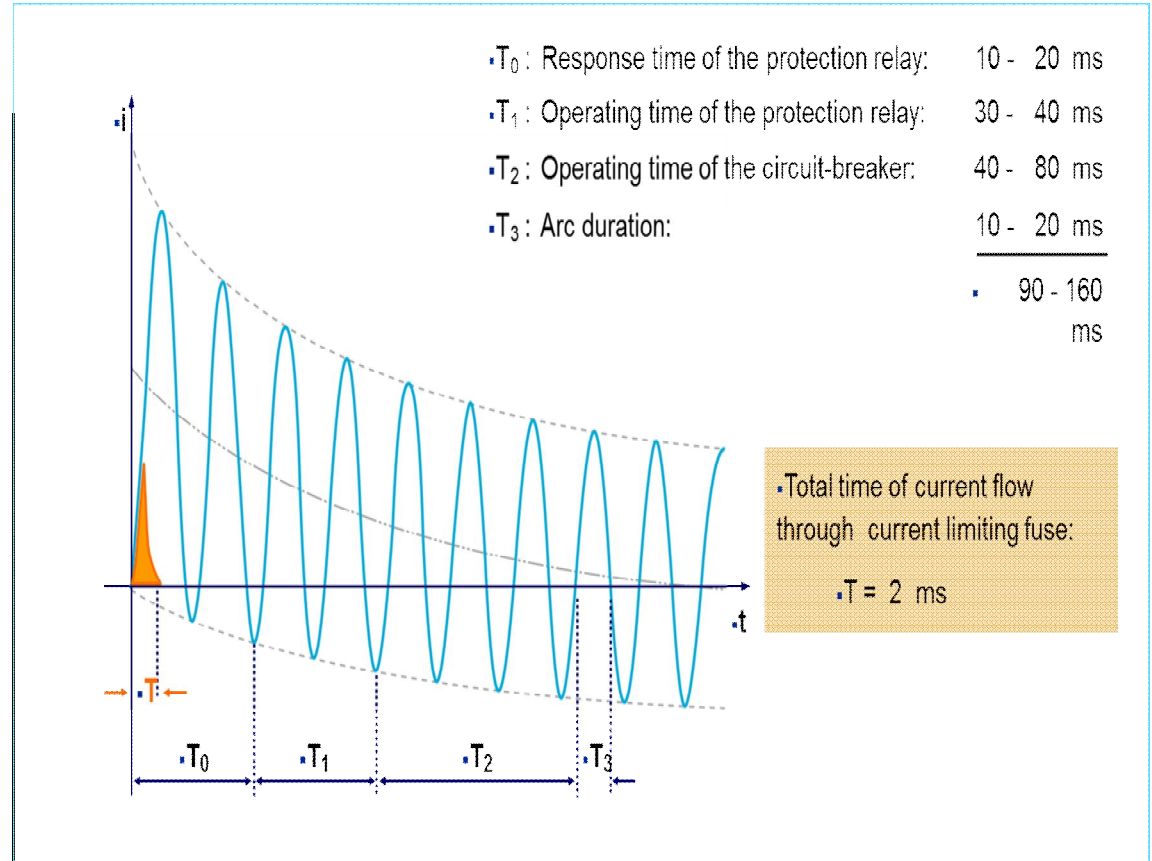

NALFWind for wind&solar farms

CSS application highlights

NALFWind in CSS

LV side protection

- Protection against short circuit that appears on LV transformer side thanks to MV CEF-S fuses with specially designed higher sensitivity for overload currents at 0.1 s
- Easy protection coordination with transformer characteristic including overload range

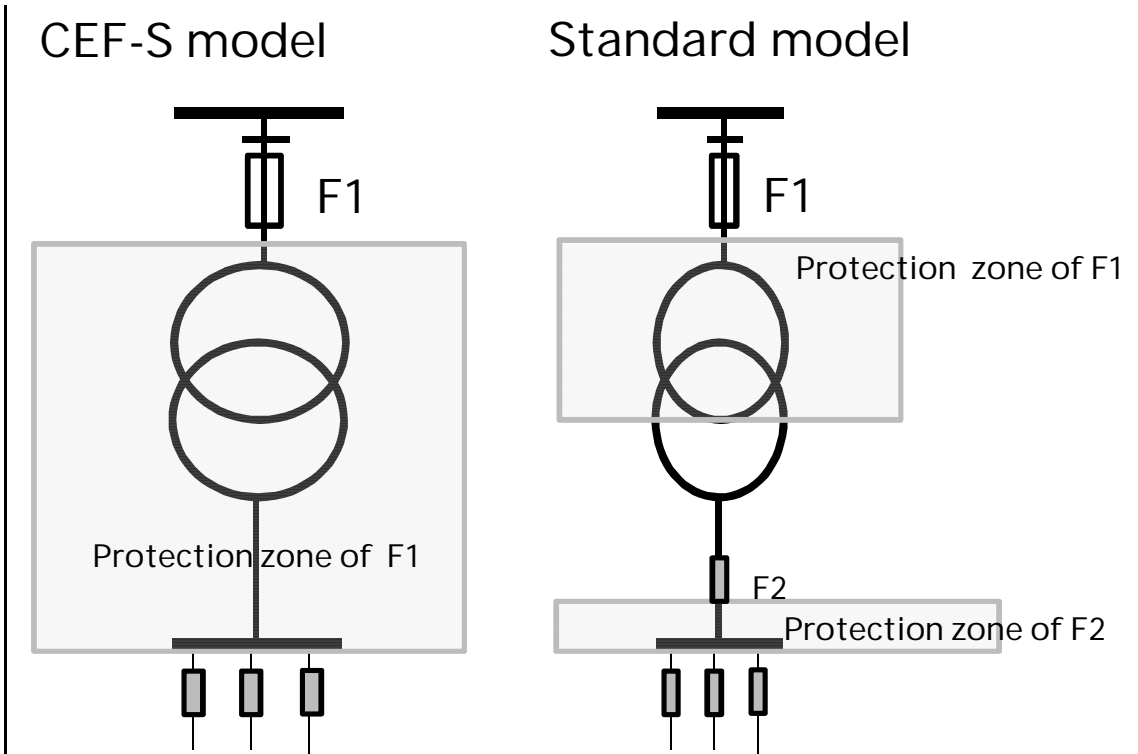

NALFWind for wind&solar farms

Summary – Customer benefits

NALFWind in CSS

New indoor air insulated switch-fuse combination with integrated earthing switch for transformer protection (up to 3 MVA at 36 kV) and completely new patented interruption system

Safety: Made to IEC standards (IEC 62271) smart design (without piston system), visible insulation break, passive voltage indicators – Reduced maintenance cost

Reliability: Stringent testing of each unit, high and unique(in air insulation) interrupting capacity – Optimized investment return

Performance: Best protecting and breaking solution for transformer protections with air insulation technology- Extended insulation life time and lower transformer protection cost



—

ABB