



Relion® Protection and Control

615 series Installation Manual



Document ID: 1MRS756375
Issued: 2010-06-11
Revision: G
Product version: 3.0

© Copyright 2010 ABB. All rights reserved

Copyright

This document and parts thereof must not be reproduced or copied without written permission from ABB, and the contents thereof must not be imparted to a third party, nor used for any unauthorized purpose.

The software or hardware described in this document is furnished under a license and may be used, copied, or disclosed only in accordance with the terms of such license.

Trademarks

ABB and Relion are registered trademarks of ABB Group. All other brand or product names mentioned in this document may be trademarks or registered trademarks of their respective holders.

Warranty

Please inquire about the terms of warranty from your nearest ABB representative.

ABB Oy
Distribution Automation
P.O. Box 699
FI-65101 Vaasa, Finland
Telephone: +358 10 2211
Facsimile: +358 10 22 41094
<http://www.abb.com/substationautomation>

Disclaimer

The data, examples and diagrams in this manual are included solely for the concept or product description and are not to be deemed as a statement of guaranteed properties. All persons responsible for applying the equipment addressed in this manual must satisfy themselves that each intended application is suitable and acceptable, including that any applicable safety or other operational requirements are complied with. In particular, any risks in applications where a system failure and/or product failure would create a risk for harm to property or persons (including but not limited to personal injuries or death) shall be the sole responsibility of the person or entity applying the equipment, and those so responsible are hereby requested to ensure that all measures are taken to exclude or mitigate such risks.

This document has been carefully checked by ABB but deviations cannot be completely ruled out. In case any errors are detected, the reader is kindly requested to notify the manufacturer. Other than under explicit contractual commitments, in no event shall ABB be responsible or liable for any loss or damage resulting from the use of this manual or the application of the equipment.

Conformity

This product complies with the directive of the Council of the European Communities on the approximation of the laws of the Member States relating to electromagnetic compatibility (EMC Directive 2004/108/EC) and concerning electrical equipment for use within specified voltage limits (Low-voltage directive 2006/95/EC). This conformity is the result of tests conducted by ABB in accordance with the product standards EN 50263 and EN 60255-26 for the EMC directive, and with the product standards EN 60255-1 and EN 60255-27 for the low voltage directive. The IED is designed in accordance with the international standards of the IEC 60255 series.

Safety information



Dangerous voltages can occur on the connectors, even though the auxiliary voltage has been disconnected.



Non-observance can result in death, personal injury or substantial property damage.



Only a competent electrician is allowed to carry out the electrical installation.



National and local electrical safety regulations must always be followed.



The frame of the IED has to be carefully earthed.



When the plug-in unit has been detached from the case, do not touch the inside of the case. The IED case internals may contain high voltage potential and touching these may cause personal injury.



The IED contains components which are sensitive to electrostatic discharge. Unnecessary touching of electronic components must therefore be avoided.



Whenever changes are made in the IED, measures should be taken to avoid inadvertent tripping.

Table of contents

Section 1	Introduction.....	3
	This manual.....	3
	Intended audience.....	3
	Product documentation.....	4
	Product documentation set.....	4
	Document revision history.....	5
	Related documentation.....	6
	Symbols and conventions.....	6
	Safety indication symbols.....	6
	Manual conventions.....	7
Section 2	Environmental aspects.....	9
	Sustainable development.....	9
	Disposing of the IED.....	9
Section 3	Unpacking, inspecting and storing.....	11
	Removing transport packaging.....	11
	Inspecting the product.....	11
	Identifying the product.....	11
	Checking delivery items.....	11
	Inspecting the IED.....	11
	Returning an IED damaged in transit.....	12
	Storing.....	12
Section 4	Mounting.....	13
	Checking environmental conditions and mounting space.....	13
	Detaching and installing the plug-in unit.....	13
	Detaching the plug-in unit.....	13
	Installing the plug-in unit.....	14
	Sealing the plug-in unit.....	15
	Mounting the IED.....	16
	Flush mounting the IED.....	16
	Semi-flush mounting the IED.....	19
	Semi-flush mounting the IED inclined.....	22
	Rack mounting the IED.....	24
	Wall mounting the IED.....	26
	Rack mounting the IED and test switch RTXP to a 19" equipment frame.....	29
	Rack mounting the IED in a combiflex 19" equipment frame (Type RHGT 19" 4U variant C).....	32

	Mounting lens sensors for an arc protection system.....	34
Section 5	Connecting.....	37
	Required tools.....	37
	Connecting wires.....	37
	Connecting ring-lug type wires.....	38
	Connecting protective earthing.....	38
	Connecting analog signals.....	39
	Connecting current and voltage inputs.....	40
	Connecting RTD and mA inputs.....	45
	Connecting IED with a test switch.....	45
	Connecting power supply.....	46
	Connecting communication.....	46
	Energizing the IED.....	47
Section 6	Removing, repairing and exchanging.....	49
	Product lifecycle.....	49
	Checking IED information.....	49
	Removing the IED.....	50
	Sending the IED for repair.....	50
	Exchanging the IED.....	50
Section 7	Technical data.....	53
	Case and HMI display variants.....	53
	Front side of the IED.....	53
	Rear side of the IED.....	55
	Dimensions.....	56
	Enclosure class.....	57
Section 8	Accessories and ordering data.....	59
Section 9	Glossary.....	61

Section 1 Introduction

1.1 This manual

The installation manual contains instructions on how to install the IED. The manual provides procedures for mechanical and electrical installation. The chapters are organized in chronological order in which the IED should be installed.

1.2 Intended audience

This manual addresses the personnel responsible for installing the product hardware.

The installation personnel must have basic knowledge of handling electronic equipment.

1.3 Product documentation

1.3.1 Product documentation set

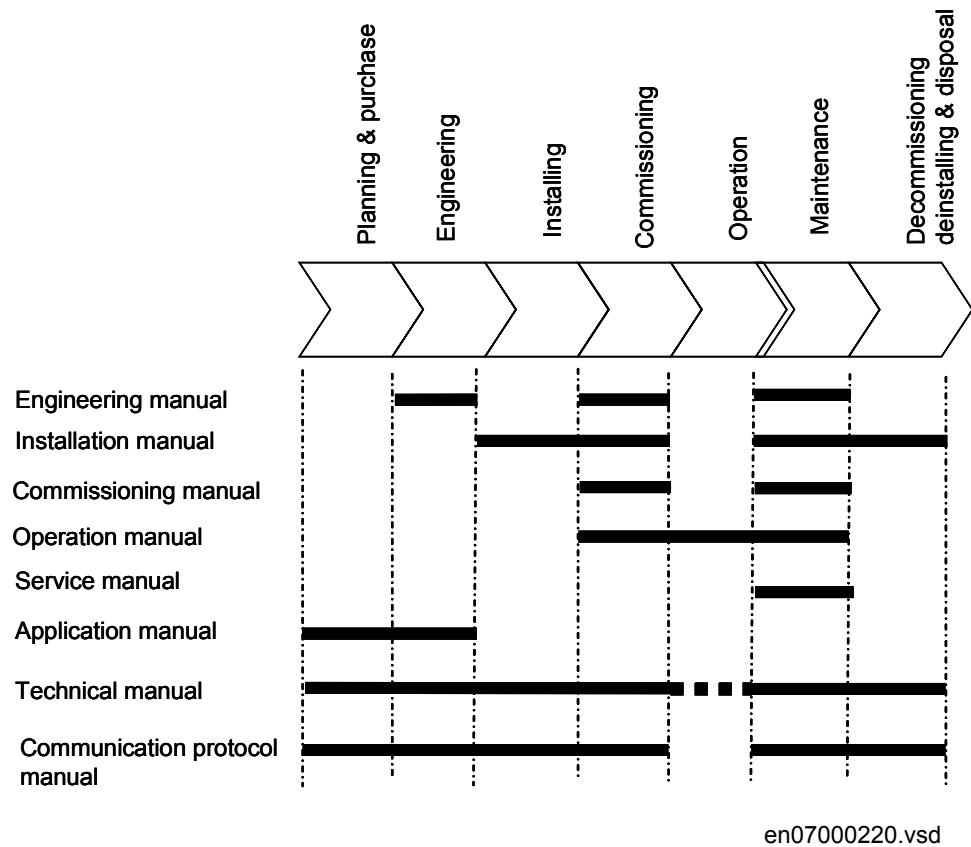

Figure 1: The intended use of manuals in different lifecycles

The engineering manual contains instructions on how to engineer the IEDs using the different tools in PCM600. The manual provides instructions on how to set up a PCM600 project and insert IEDs to the project structure. The manual also recommends a sequence for engineering of protection and control functions, LHMI functions as well as communication engineering for IEC 61850 and other supported protocols.

The installation manual contains instructions on how to install the IED. The manual provides procedures for mechanical and electrical installation. The chapters are organized in chronological order in which the IED should be installed.

The commissioning manual contains instructions on how to commission the IED. The manual can also be used by system engineers and maintenance personnel for assistance during the testing phase. The manual provides procedures for checking of external circuitry and energizing the IED, parameter setting and configuration as

well as verifying settings by secondary injection. The manual describes the process of testing an IED in a substation which is not in service. The chapters are organized in chronological order in which the IED should be commissioned.

The operation manual contains instructions on how to operate the IED once it has been commissioned. The manual provides instructions for monitoring, controlling and setting the IED. The manual also describes how to identify disturbances and how to view calculated and measured power grid data to determine the cause of a fault.

The service manual contains instructions on how to service and maintain the IED. The manual also provides procedures for de-energizing, de-commissioning and disposal of the IED.

The application manual contains application descriptions and setting guidelines sorted per function. The manual can be used to find out when and for what purpose a typical protection function can be used. The manual can also be used when calculating settings.

The technical manual contains application and functionality descriptions and lists function blocks, logic diagrams, input and output signals, setting parameters and technical data sorted per function. The manual can be used as a technical reference during the engineering phase, installation and commissioning phase, and during normal service.

The communication protocol manual describes a communication protocol supported by the IED. The manual concentrates on vendor-specific implementations.

The point list manual describes the outlook and properties of the data points specific to the IED. The manual should be used in conjunction with the corresponding communication protocol manual.



Some of the manuals are not available yet.

1.3.2

Document revision history

Document revision/date	Product series version	History
A/2007-12-20	1.0	First release
B/2008-02-08	1.0	Content updated
C/2008-07-02	1.1	Content updated to correspond to the product series version
D/2008-10-03	1.1	Content updated
E/2009-03-04	2.0	Content updated to correspond to the product series version
F/2009-07-03	2.0	Content updated
G/2010-06-11	3.0	Content updated to correspond to the product series version



Download the latest documents from the ABB web site <http://www.abb.com/substationautomation>.

1.3.3 Related documentation

Product series- and product-specific manuals can be downloaded from the ABB web site <http://www.abb.com/substationautomation>.

1.4 Symbols and conventions

1.4.1 Safety indication symbols



The electrical warning icon indicates the presence of a hazard which could result in electrical shock.



The warning icon indicates the presence of a hazard which could result in personal injury.



The caution icon indicates important information or warning related to the concept discussed in the text. It might indicate the presence of a hazard which could result in corruption of software or damage to equipment or property.



The information icon alerts the reader to important facts and conditions.





The tip icon indicates advice on, for example, how to design your project or how to use a certain function.

Although warning hazards are related to personal injury, it should be understood that operation of damaged equipment could, under certain operational conditions, result in degraded process performance leading to personal injury or death. Therefore, comply fully with all warning and caution notices.

1.4.2 Manual conventions

Conventions used in IED manuals. A particular convention may not be used in this manual.

- Abbreviations and acronyms in this manual are spelled out in the glossary. The glossary also contains definitions of important terms.
- Push button navigation in the LHMI menu structure is presented by using the push button icons, for example:
To navigate between the options, use  and .
- HMI menu paths are presented in bold, for example:
Select **Main menu/Settings**.
- LHMI messages are shown in Courier font, for example:
To save the changes in non-volatile memory, select `Yes` and press .
- Parameter names are shown in italics, for example:
The function can be enabled and disabled with the *Operation* setting.
- Parameter values are indicated with quotation marks, for example:
The corresponding parameter values are "On" and "Off".
- IED input/output messages and monitored data names are shown in Courier font, for example:
When the function starts, the `START` output is set to `TRUE`.

Section 2 Environmental aspects

2.1 Sustainable development

Sustainability has been taken into account from the beginning of the product design including the pro-environmental manufacturing process, long life time, operation reliability and disposing of the IED.

The choice of materials and the suppliers have been made according to the EU RoHS directive (2002/95/EC). This directive limits the use of hazardous substances which are the following:

Table 1: *Maximum concentration values by weight per homogeneous material*

Substance	Proposed maximum concentration
Lead - Pb	0.1%
Mercury - Hg	0.1%
Cadmium - Cd	0.01%
Hexavalent Chromium Cr (VI)	0.1%
Polybrominated biphenyls - PBB	0.1%
Polybrominated diphenyl ethers - PBDE	0.1%

Operational reliability and long life time have been assured with extensive testing during the design and manufacturing processes. Moreover, long life time is supported by maintenance and repair services as well as by the availability of spare parts.

Design and manufacturing have been done under a certified environmental system. The effectiveness of the environmental system is constantly evaluated by an external auditing body. We follow environmental rules and regulations systematically to evaluate their effect on our products and processes.

2.2 Disposing of the IED

Definitions and regulations of hazardous materials are country-specific and change when the knowledge of materials increases. The materials used in this product are typical for electric and electronic devices.

All parts used in this product are recyclable. When disposing of an IED or its parts contact a local waste handler who is authorized and specialized in disposing

electronic waste. These handlers can sort the material by using dedicated sorting processes and dispose of the product according to the local requirements.

Table 2: Materials of the IED parts

IED	Parts	Material
Case	Metallic plates, parts and screws	Steel
	Plastic parts	PC ¹⁾ , LCP ²⁾
	Electronics plug in module	Various
Plug-in unit	Electronics plug in modules	Various
	Electronics LHMI module	Various
	Plastic parts	PC, PBT ³⁾ , LCP, PA ⁴⁾
	Metallic parts	Aluminium
Package	Box	Cardboard
Attached material	Manuals	Paper

- 1) Polycarbonate
- 2) Liquid crystal polymer
- 3) Polybutylene terephthalate
- 4) Polyamide

Section 3 Unpacking, inspecting and storing

3.1 Removing transport packaging

IEDs require careful handling.

1. Examine the delivered products to ensure that they have not been damaged during the transport.
2. Remove the transport packing carefully without force.



The cardboard packaging material is 100% recyclable.

3.2 Inspecting the product

3.2.1 Identifying the product

1. Locate the IED's order number from the label on top of the plug-in unit.
2. Compare the IED's order number with the ordering information to verify that the received product is correct.

3.2.2 Checking delivery items

Check that all items are included in the delivery in accordance with the delivery documents.

3.2.3 Inspecting the IED

IEDs require careful handling before installation on site.

- Check the IED to see if any damage occurred during transportation.

If the IED has damaged during transportation, make a claim against the transport contractor, and notify the local ABB representative.

3.2.4 Returning an IED damaged in transit

If damage has occurred during transport, appropriate actions must be taken against the latest carrier. Please inform the nearest ABB office or representative. ABB should be notified immediately if there are any discrepancies in relation to the delivery documents.

3.3 Storing

If the IED is stored before installation, it must be done in the original transport packaging in a dry and dust free place. Observe the environmental requirements stated in the technical manual.

Section 4 Mounting

4.1 Checking environmental conditions and mounting space

The mechanical and electrical environmental conditions at the installation site must be within the limits described in the technical manual.

- Avoid installation in dusty, damp places.
Avoid places susceptible to rapid temperature variations, powerful vibrations and shocks, surge voltages of high amplitude and fast rise time, strong induced magnetic fields or similar extreme conditions.
- Check that sufficient space is available.
Sufficient space is needed at the front and rear of the IED to allow access to wires and optical fibres and to enable maintenance and future modifications.
- Flush mounted IEDs should be possible to be added or replaced without excessive dismantling.

4.2 Detaching and installing the plug-in unit

4.2.1 Detaching the plug-in unit



Before detaching the plug-in unit from the case, the auxiliary voltage must be disconnected.

1. Turn off the power.
2. Open the seal on the front panel by removing the sealing wire and screw the sealing screw all the way in.
3. Lift the handle to 90 degrees to release the latching mechanism.
The plug-in unit is pushed about 7 mm out of the case and the connectors are separated.
4. Pull the unit out of the case.

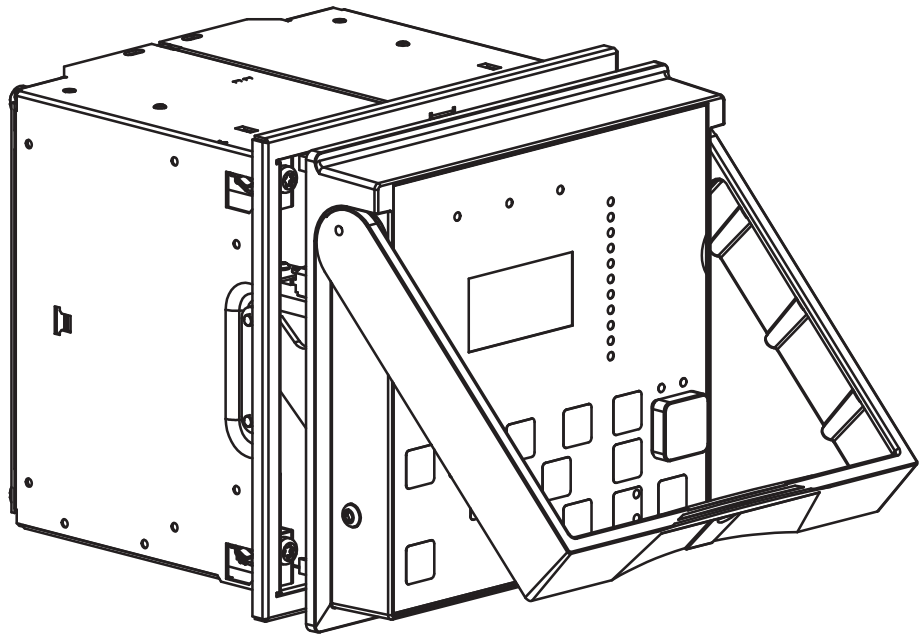

Figure 2: Detaching a plug-in unit from the case



The IED features an automatic short-circuit mechanism in the CT connector. Therefore, detaching the plug-in unit will not open the secondary circuit of the CT which could cause dangerously high voltages.



The signal connectors are left open when the plug-in unit is detached.

4.2.2

Installing the plug-in unit



Before fitting the plug-in unit into the case, check that the unit and the case have the same serial number.

The IED is built (or constructed) in a way that a plug-in unit with voltage or current measuring inputs can only be plugged into a corresponding case. This prevents fitting a non-suitable plug-in unit into a wrong case.



Forcing a non-suitable plug-in unit into the case can break both the plug-in unit and the case and may cause danger.

1. Lift the handle to its fully opened position (90 degrees).
2. Push the plug-in unit into the case as far as it goes.
3. Turn down the handle completely to push plug-in unit into it's final position in the case.

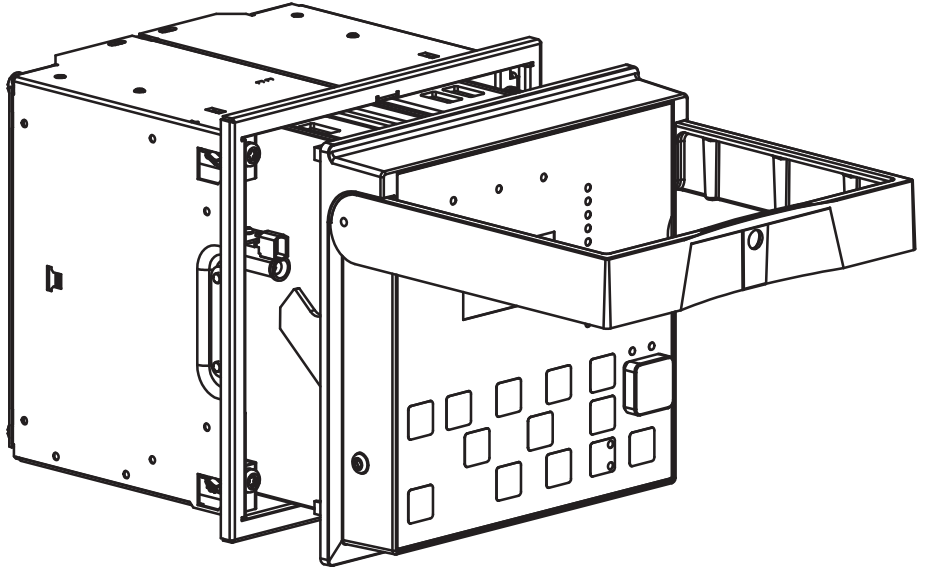

Figure 3: Installing a plug-in unit into the case

4.2.3

Sealing the plug-in unit

The front panel of the IED has an integrated sealing screw. By default the screw is screwed all the way in and is not used when installing or detaching the plug-in unit.

1. Open the sealing screw about nine turns.
2. Thread a sealing wire trough the holes in the sealing screw and the handle.

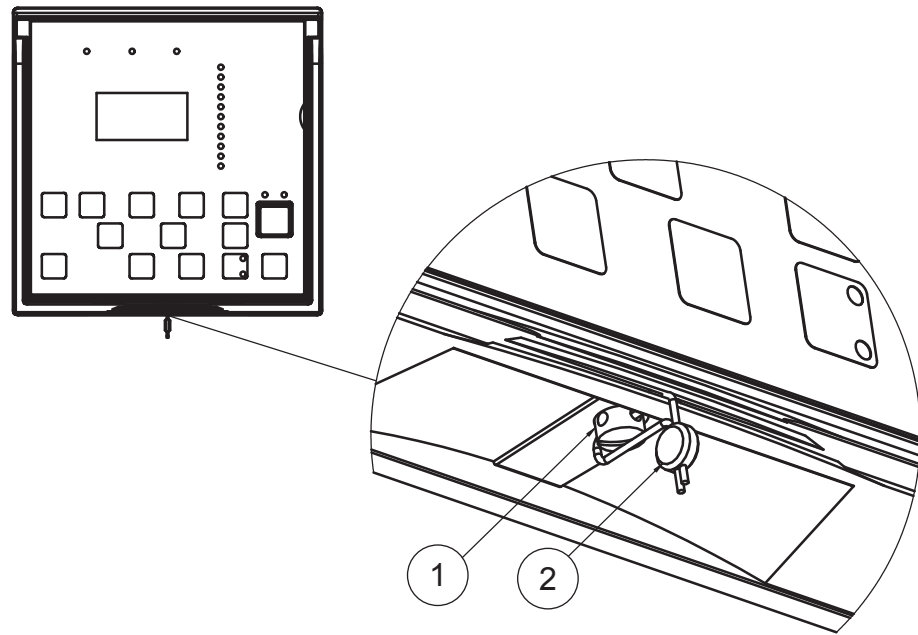

Figure 4: Sealing screw

- 1 Sealing screw
- 2 Sealing wire and seal

4.3 Mounting the IED

4.3.1 Flush mounting the IED

All the mounting elements are integrated in the IED.

Requirements for installation:

- Panel cut-out of 165.5 x 161.5 mm
- Depth behind the panel 153 mm



An IED equipped with optical connections requires a minimum depth of 180 mm. The allowed minimum bending radius has to be checked from the optical cable manufacturer.

1. Loosen the four M5 fixing screws in the case to fit the case into the panel cut-out.
2. Mount the case to the panel cut-out.

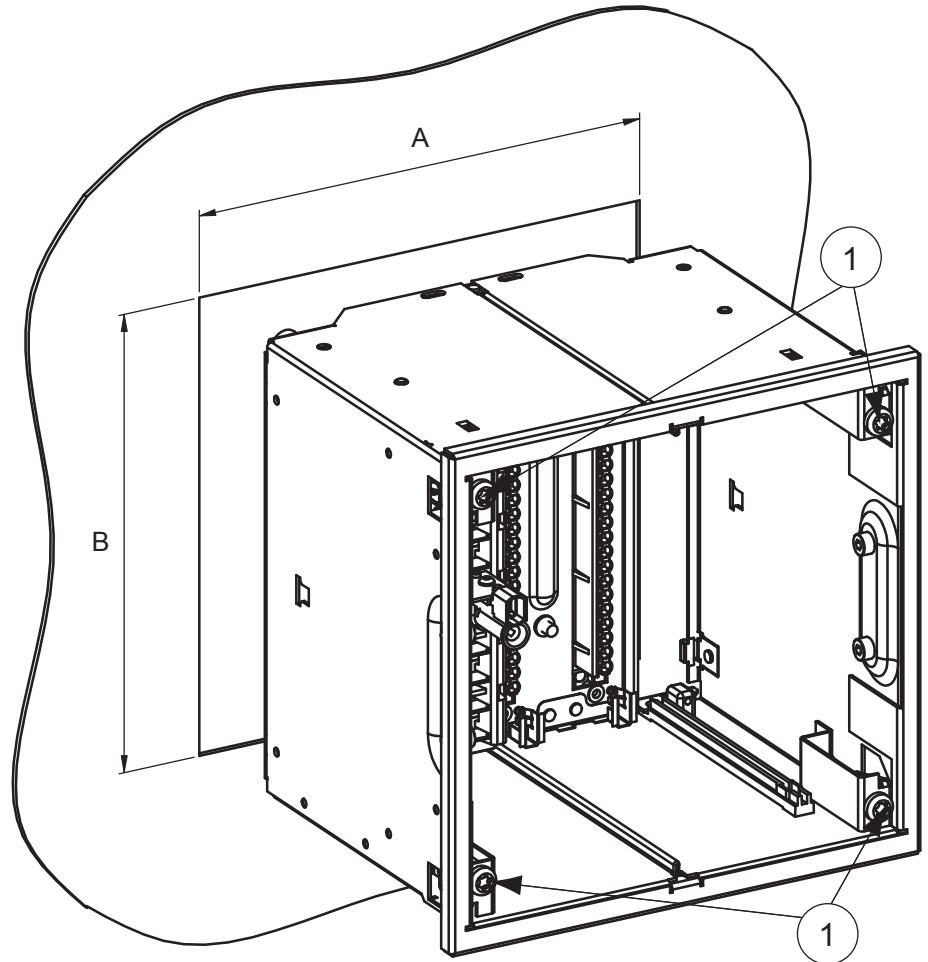

Figure 5: Flush mounting a case into a panel cut-out

A 165.5 ±1 mm 1 M5 fixing screws

B 161.5 ±1 mm

3. Tighten the M5 screws.
The allowed range for the fixing screws' tightening torque is 0.7...1 Nm.

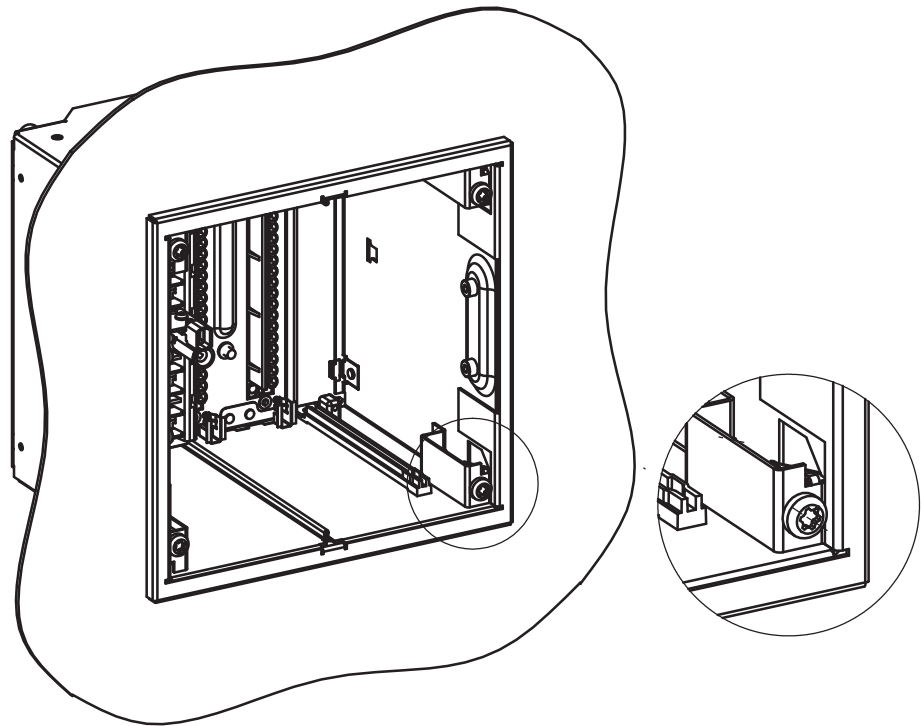

Figure 6: Flush mounted case, tightening the M5 fixing screws

4. Install the plug-in unit into the case.

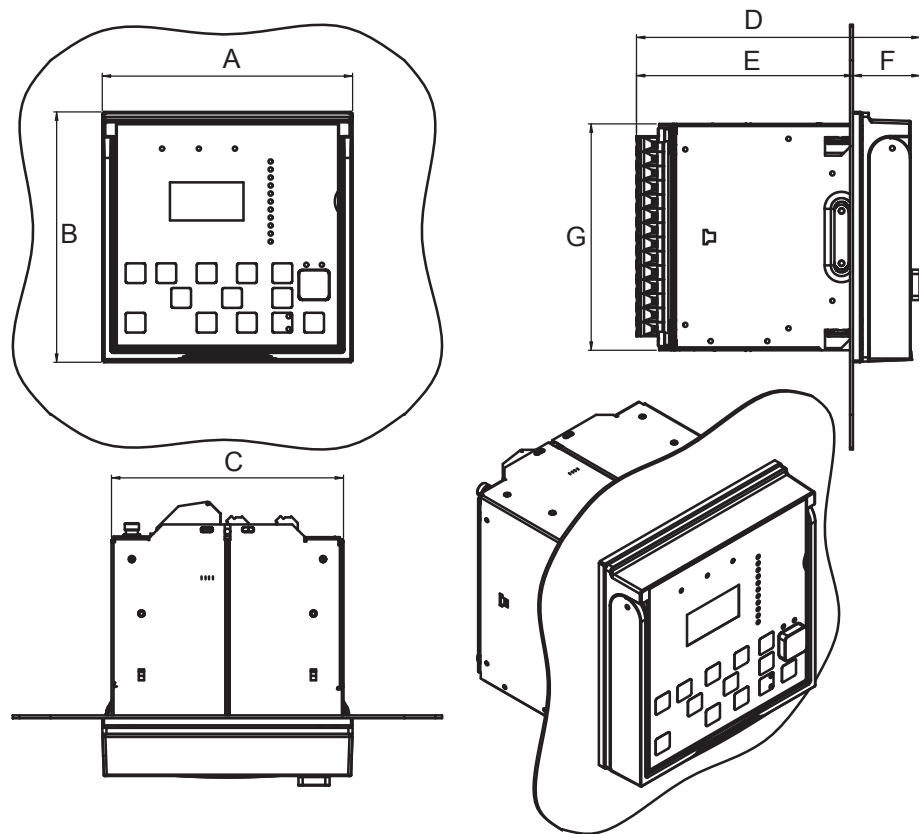

Figure 7: Flush mounted case and plug-in unit

- A 177 mm
- B 177 mm
- C 164 mm
- D 201 mm
- E 153 mm
- F 48 mm
- G 160 mm

4.3.2

Semi-flush mounting the IED

A mounting kit is needed for semi-flush mounting the IED. In addition to the detailed mounting instructions, the mounting kit includes:

- Raising frame
- Gasket
- Screws

Requirements for installation:

- Panel cut-out of 165.5 x 161.5 mm with mounting holes
- Depth behind the panel 103 mm
- When IP 54 degree of protection (according to IEC 60529) is required for the front side, a gasket has to be used in the installation.

1. Mount the raising frame into the panel cut-out with four M4 screws.

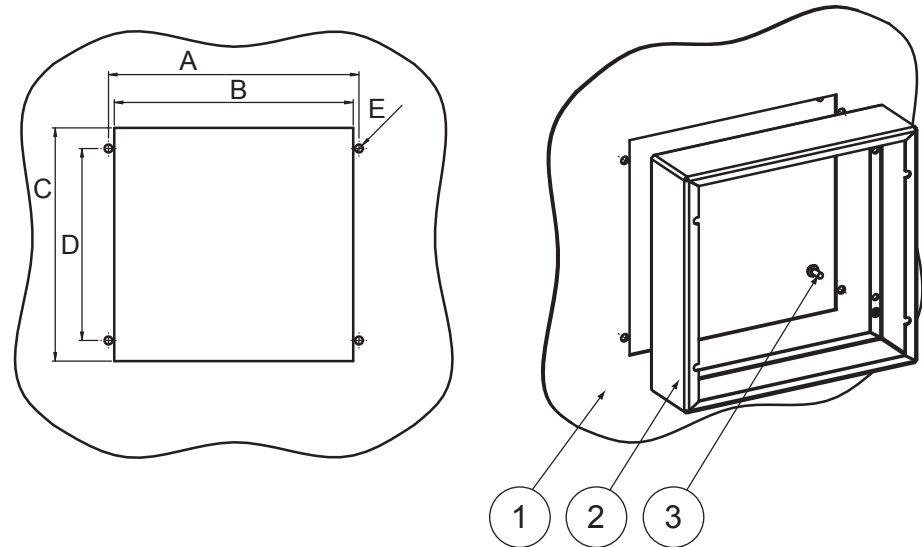

Figure 8: Mounting the raising frame

A	173.5 ±0.3 mm	1	Panel
B	165.5 ±1 mm	2	Raising frame
C	161.5 ±1 mm	3	M4 screw
D	133 ±0.3 mm		
E	∅ 5.5 mm		

2. Loosen the four M5 fixing screws in the case to fit the case to the raising frame.
3. Mount the case to the raising frame.

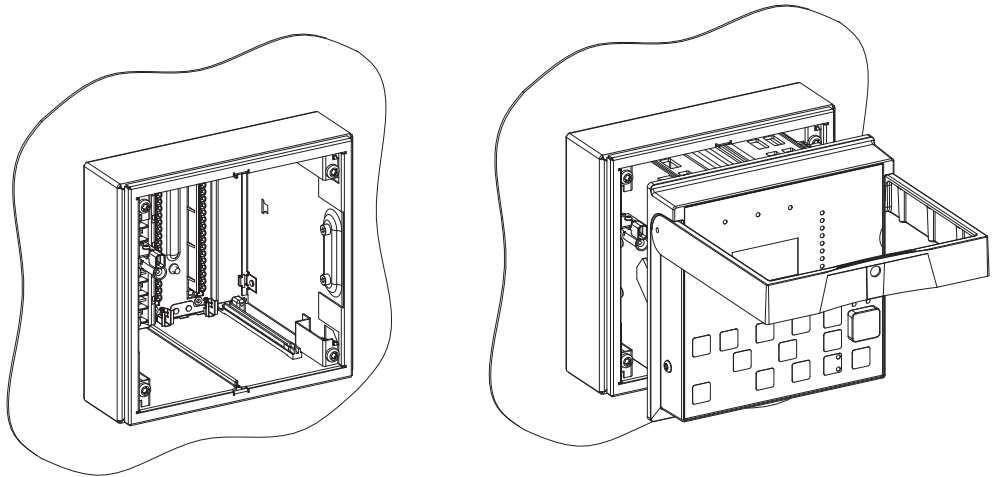

Figure 9: Mounting the case

4. Tighten the M5 screws.
The allowed range for the fixing screws' tightening torque is 0.7...1 Nm.
5. Install the plug-in unit into the case.

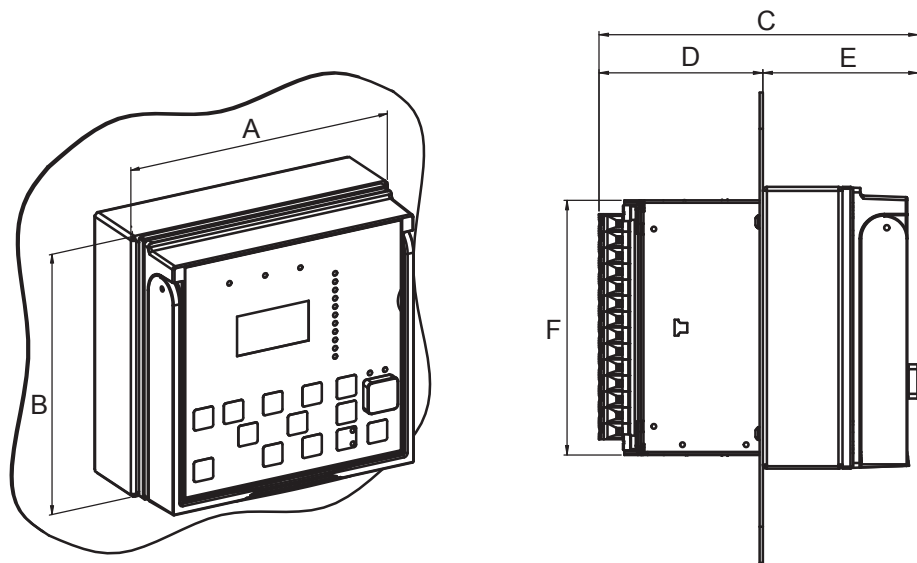

Figure 10: Semi-flush mounted IED

- A 186 mm
- B 177 mm
- C 201 mm
- D 103 mm
- E 98 mm
- F 160 mm

4.3.3 Semi-flush mounting the IED inclined

A mounting kit is needed for semi-flush mounting the IED inclined. In addition to the detailed mounting instructions, the mounting kit includes:

- Angle frame
- Gasket
- Screws

Requirements for installation:

- Panel cut-out of 167 x 203 mm with mounting holes
- Depth behind the panel 107 mm
- When IP 54 degree of protection (according to IEC 60529) is required for the front side, a gasket has to be used in the installation.

1. Mount the angle frame into the panel cut-out with four M4 screws.

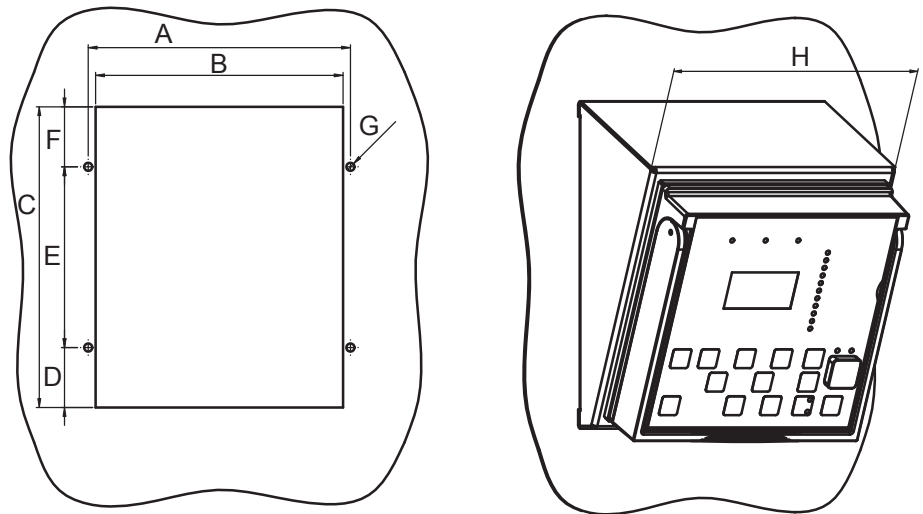

Figure 11: Mounting the angled frame

- A 177 ±0.3 mm
- B 167 ±1 mm
- C 203 ±1 mm
- D 40.5 mm
- E 122 mm
- F 40.5 mm
- G Ø 5.5 mm
- H 190 mm

2. Loosen the four M5 fixing screws in the case to fit the case into the angle frame.
3. Mount the case to the angle frame.
With the angled frame, the IED can be mounted inclined downward to a 25° angle.
4. Tighten the screws.
The allowed range for the fixing screws' tightening torque is 0.7...1 Nm.
5. Install the plug-in unit into the case.

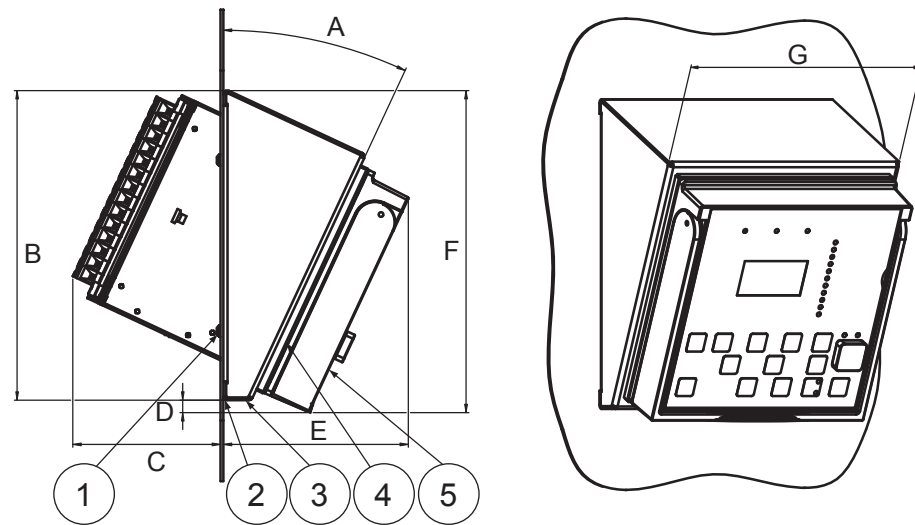

Figure 12: IED semi-flush mounted inclined

A	25 °	1	M4 screws
B	221 mm	2	Gasket
C	107 mm	3	Angled frame
D	9 mm	4	Case
E	133 mm	5	Plug-in unit
F	230 mm		
G	190 mm		

4.3.4

Rack mounting the IED

A mounting kit is needed for rack mounting the IED. In addition to the detailed mounting instructions, the 19" rack mounting kit includes:

- Mounting panel; the type of the mounting panel depends on the number of mounted relays
- Screws

1. Mount the mounting panel to a 19" rack.
2. Loosen the four M5 fixing screws in the case to fit the case into the panel cut-out.
3. Mount the case to the panel cut-out.

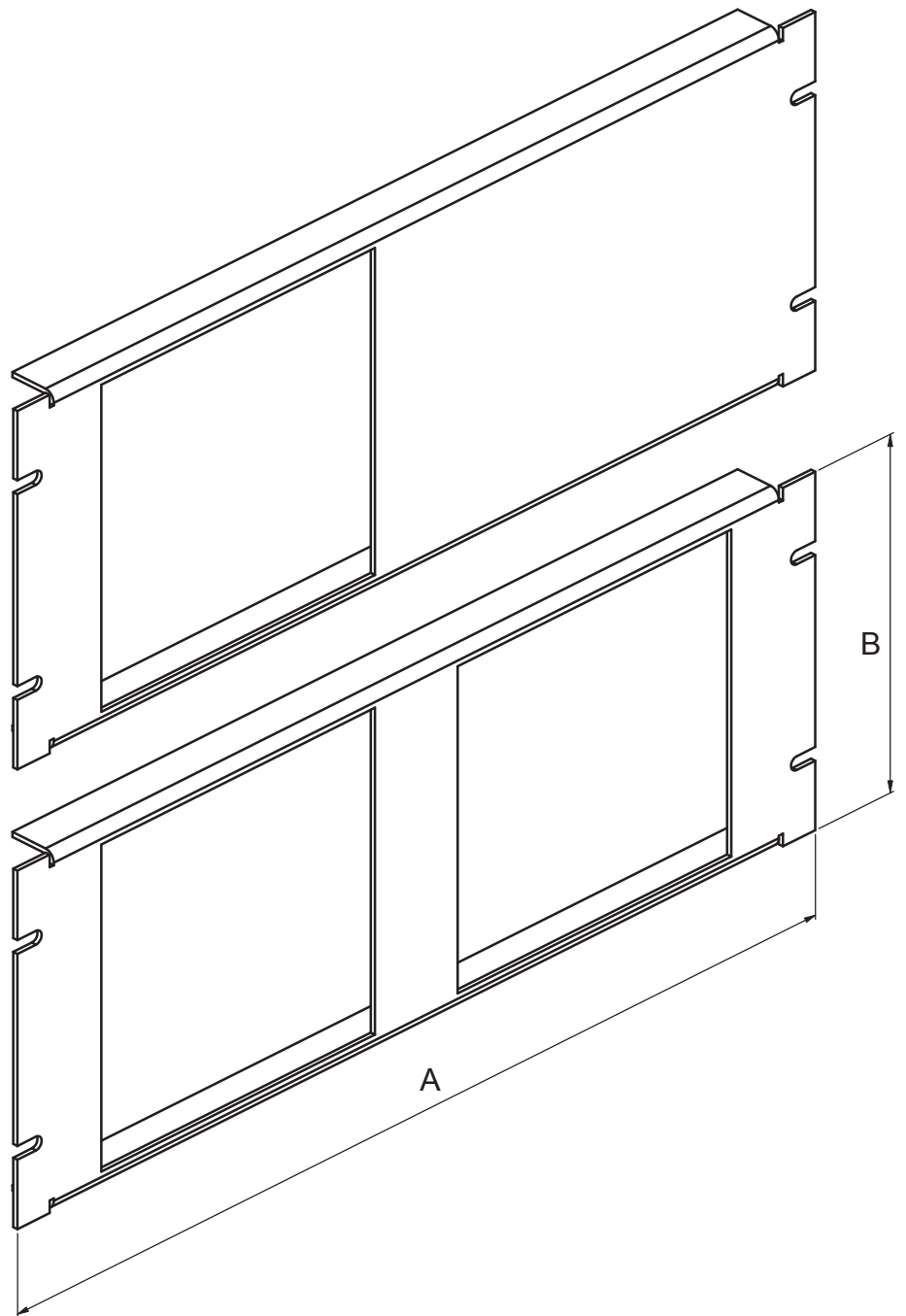

Figure 13: 19" rack mounting panels

A 482.6 mm (19")

B 177 mm (4U)

4. Tighten the screws.

- The allowed range for the fixing screws' tightening torque is 0.7...1 Nm.
5. Install the plug-in unit into the case.

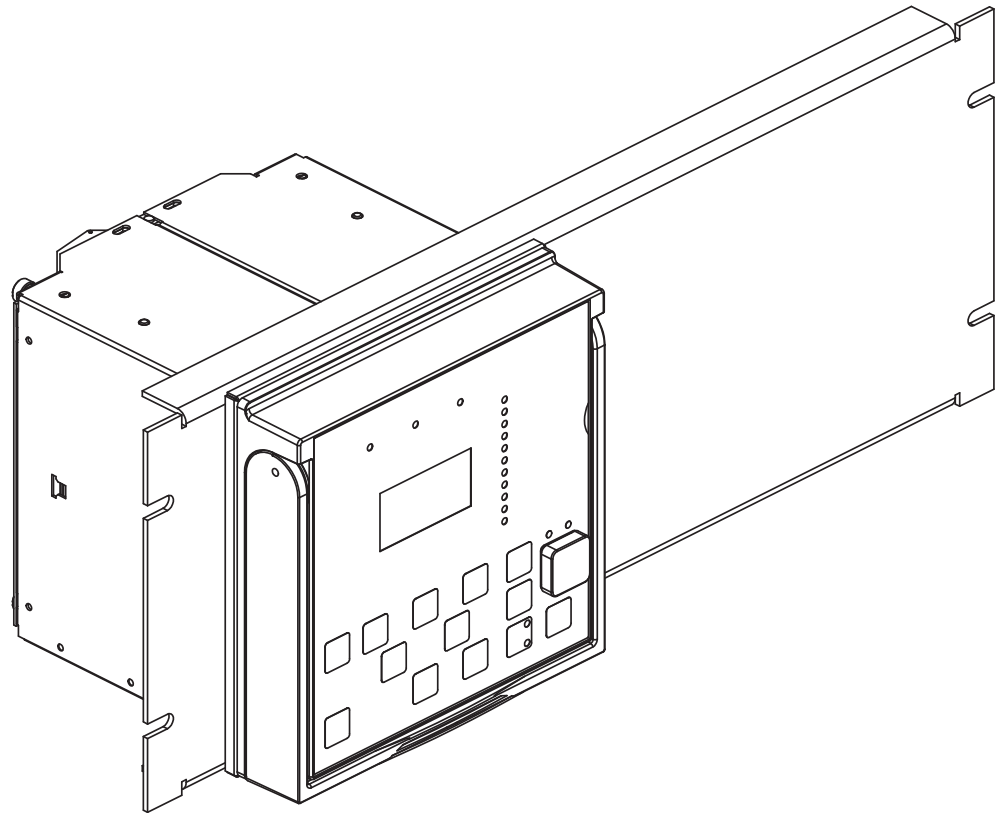

Figure 14: Rack mounted IED

4.3.5

Wall mounting the IED

A mounting kit is needed for wall mounting the IED. In addition to the detailed mounting instructions, the wall mounting kit includes:

- Wall mounting frame and rail parts
 - Back plate
 - Screws
 - Dimensions for screw holes
1. Drill screw holes according to the dimensional drawing.
 2. Mount the wall mounting frame and the rails.
 3. Install the back plate.
 4. Loosen the four M5 fixing screws in the case to fit the case into the mounting frame.
 5. Mount the case between the rails.

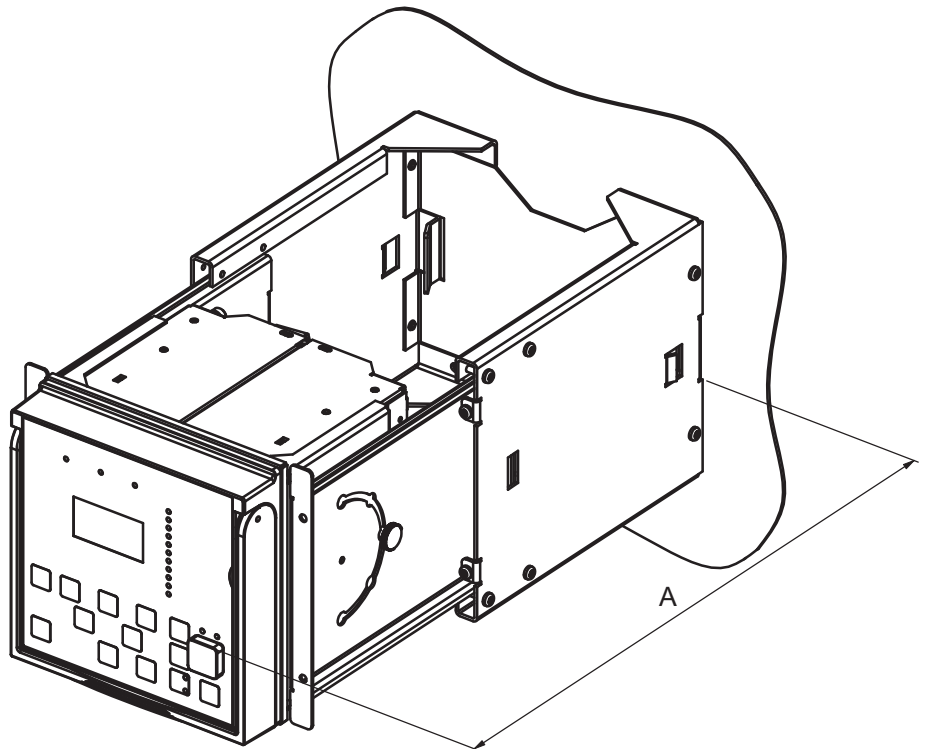

Figure 15: Wall mounting the IED

A 430 mm

6. Tighten the screws.
The allowed range for the fixing screws' tightening torque is 0.7...1 Nm.

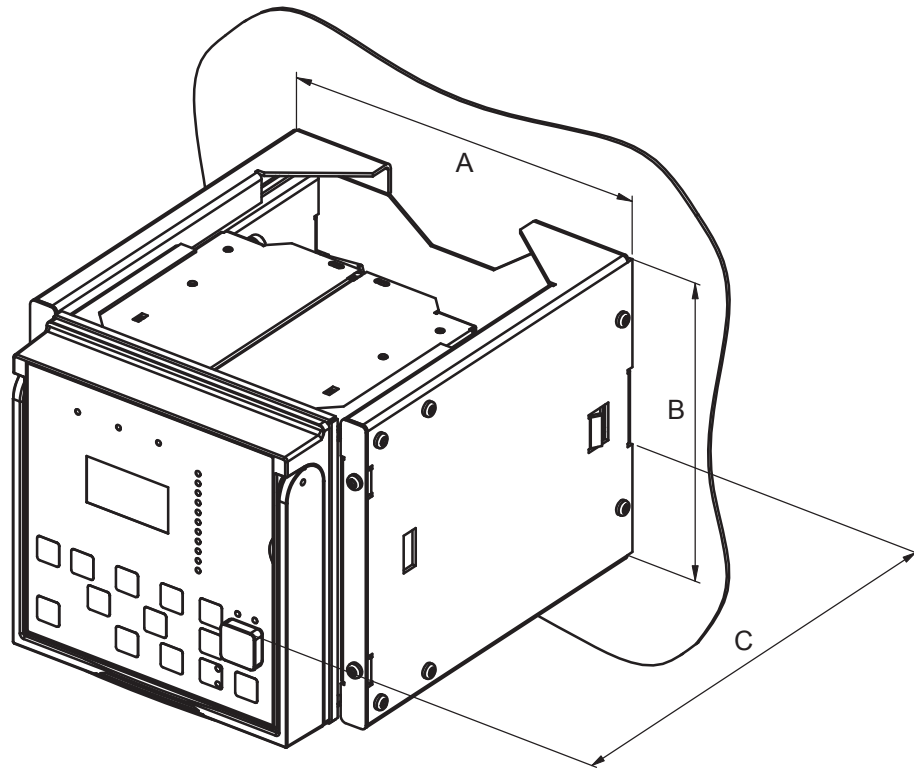

Figure 16: Wall mounted IED

- A 214 mm
- B 177 mm
- C 270 mm



Minimum of 50 mm space is needed between two kits.

When connecting the wires, a wall-mounted IED can be pulled out and turned 45° (or 90°) degrees downwards or upwards.

- To release the IED for pulling it out, push the locks beside the mounting frame.
- To rotate the IED, loosen the knurled-head screws in the rails.

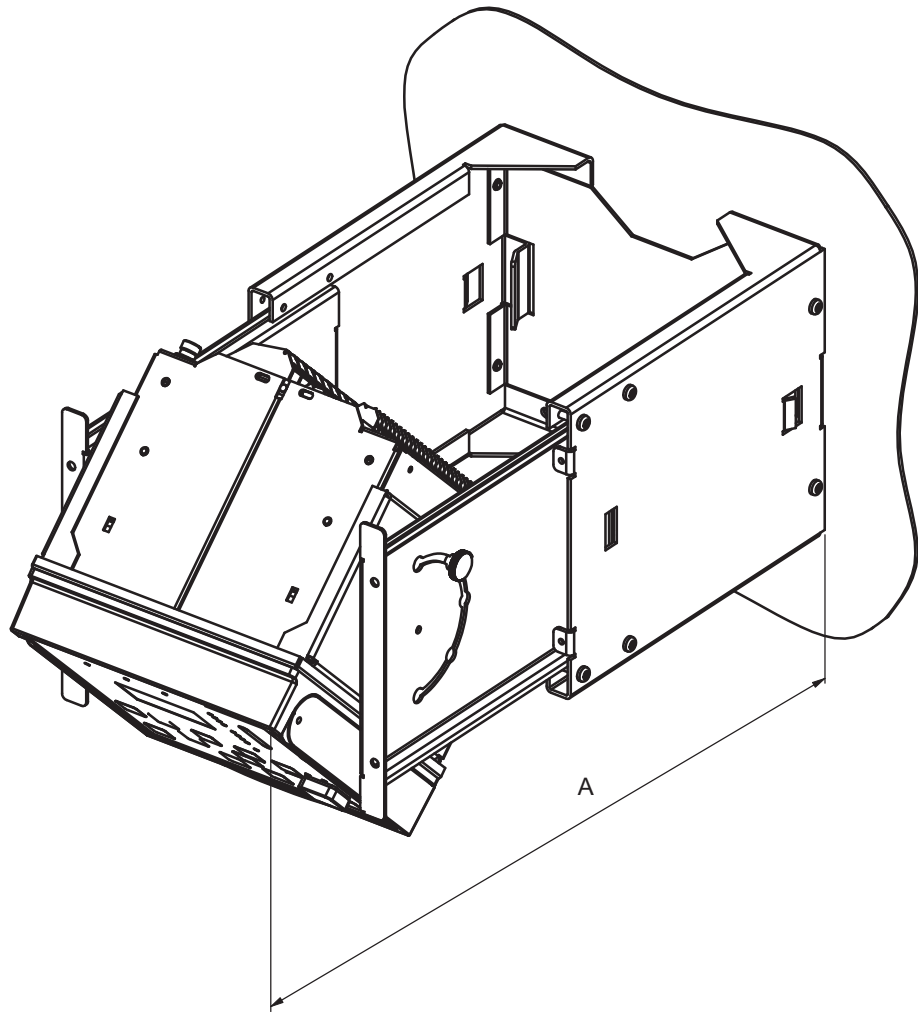

Figure 17: Wall mounted IED in rotated position

A 455 mm



Minimum of 50 mm space is needed above and below the frame for rotating.

4.3.6

Rack mounting the IED and test switch RTXP to a 19" equipment frame

A mounting kit is needed for rack mounting the IED in a 19" equipment frame. In addition to the detailed mounting instructions, the mounting kit includes:

- Mounting panel
- Metallic frame for mounting the RTXP 18 or 24 test switch to the panel



An IED equipped with optical connections requires a minimum depth of 180 mm. The allowed minimum bending radius has to be checked from the optical cable manufacturer.

To rack mount the IED into a 19" equipment frame:

1. Mount the mounting panel into the 19" rack.
2. Loosen the four M5 fixing screws in the case to fit the case into the panel cut-out.
3. Mount the case to the panel cut-out.
4. Install the optional metallic frame to mount the RTXP 18 or 24 test switch to the panel.

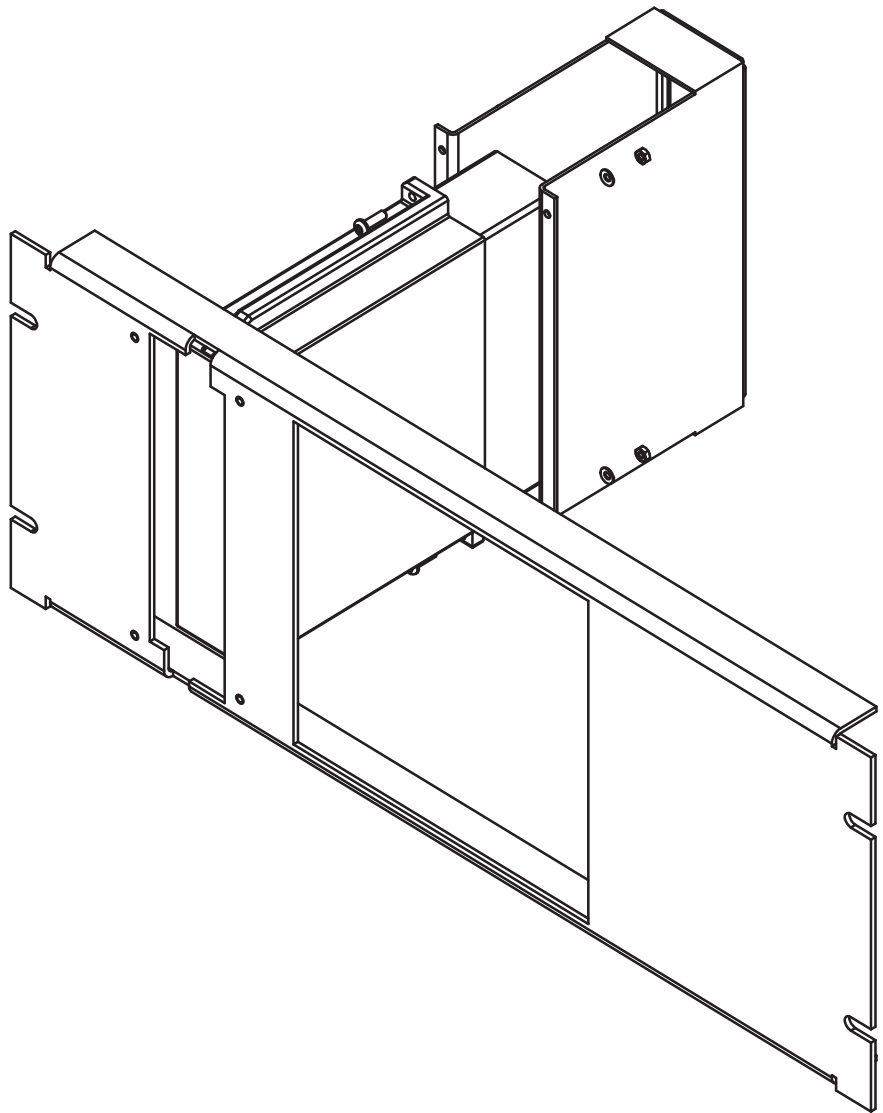

Figure 18: Mounting of the metallic frame for an RTXP 18 test switch

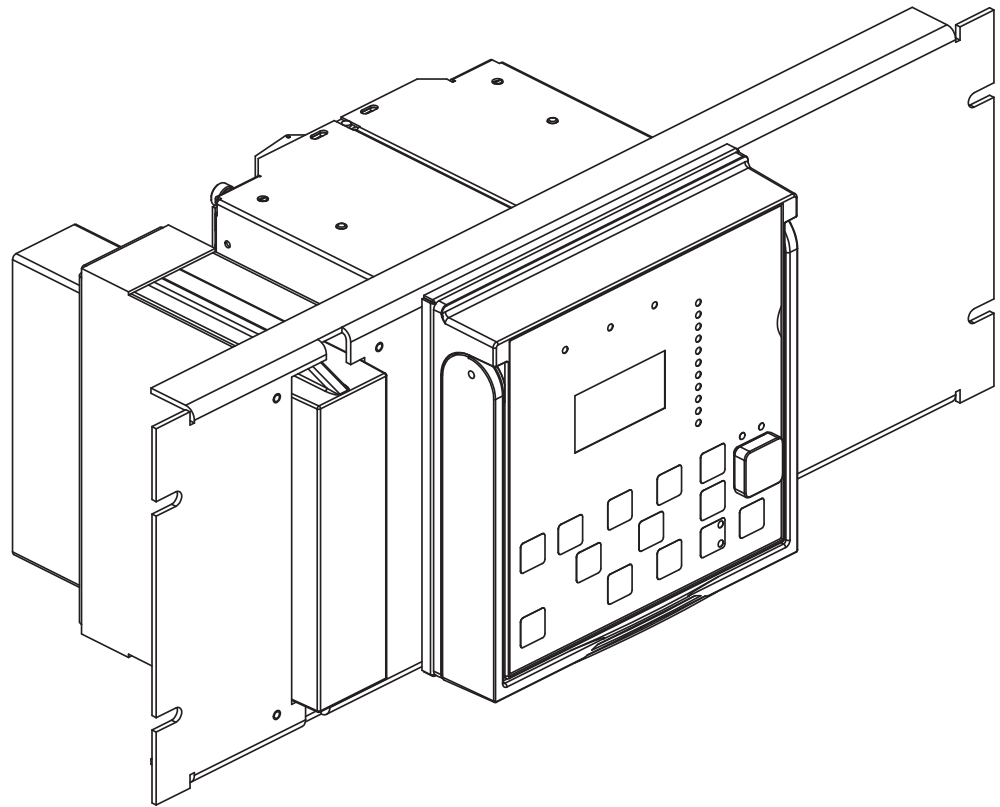

Figure 19: IED and the test switch RTXP 18 mounted into a 19" equipment panel

4.3.7

Rack mounting the IED in a combiflex 19" equipment frame (Type RHGT 19" 4U variant C)

A mounting bracket is needed for rack mounting the IED into a combiflex 19" equipment frame, a different bracket is in installation with test switch. In addition to the detailed mounting instructions, the mounting kit includes:

- Mounting bracket for the case and optionally with RTXP test switch

1. Install the mounting bracket into the combiflex equipment frame by using tapping screws ST3.5x13 from rear side.



The type of mounting bracket to be used depends on whether the IED is installed into the frame on its own or with a test switch.

2. Loosen the four M5 fixing screws in the case to fit the case into the mounting bracket.
3. Mount the case to the mounting bracket.
4. Tighten the M5 screws.

- The allowed range for the fixing screws' tightening torque is 0.7...1 Nm.
5. Install the plug-in unit into the case.

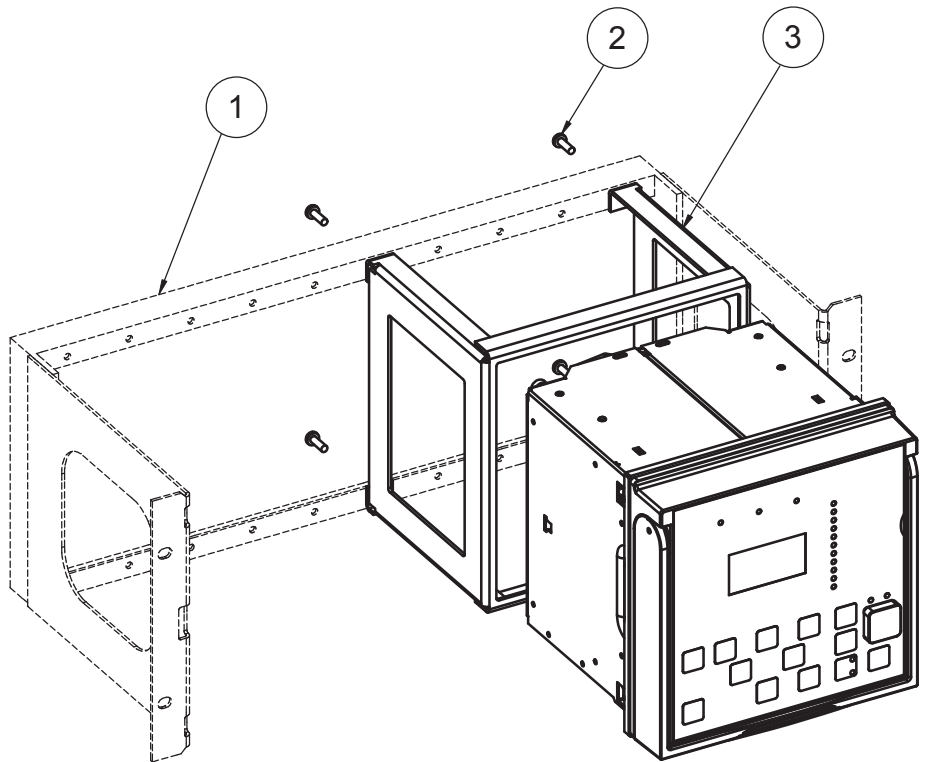

Figure 20: Mounting the IED into a 19" combiflex equipment frame

- 1 RHGT 19" 4U equipment frame, variant C, with support frame
- 2 Tapping screw ST3.5x13
- 3 Mounting bracket

6. Install the optional RTXP 18 or 24 test switch.

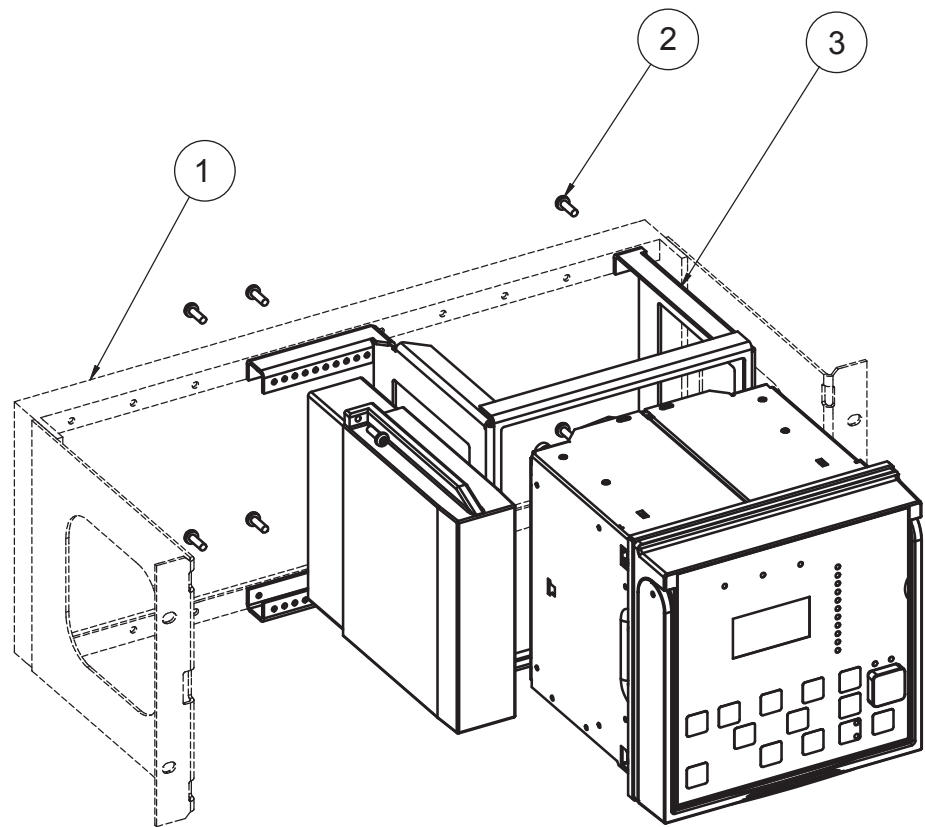

Figure 21: IED and the test switch

- 1 RHGT 19" 4U equipment frame, variant C, with support frame
- 2 Tapping screw ST3.5x13
- 3 Mounting bracket for mounting with test switch RTXP 18

4.3.8

Mounting lens sensors for an arc protection system

Arc protection is used to detect arc situations in air insulated metal-clad switchgear.

The arc protection system determines where in the switchgear cubicle the optional lens sensors are installed. See the application examples in the application manual for further information on the alternatives.

1. Drill a hole (\varnothing 10 mm) in the wall of the supervised space.

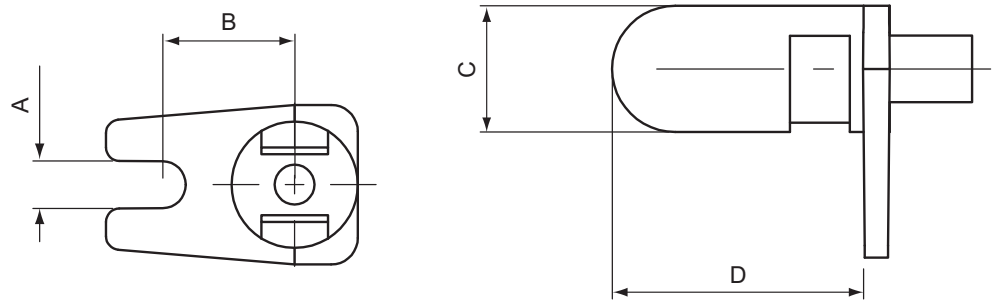

Figure 22: Dimensions of the lens sensor

- A 3.5 mm
- B 10 mm
- C \varnothing 9.5 mm
- D 19 mm

2. Fit the lens sensor into the hole and fasten it with a self-tapping M3 screw. Alternatively, the lens sensor can be fastened with a cable tie. To do this, secure the cable tie to a suitable point of attachment on the cubicle wall and wrap the cable tie tightly around the sensor.

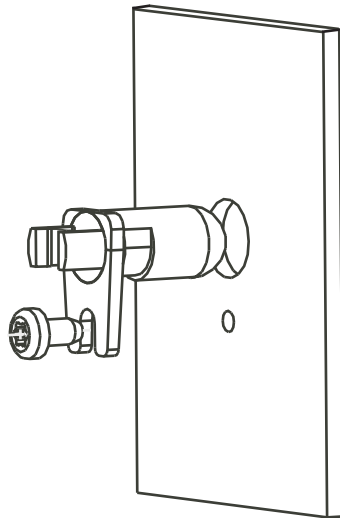

Figure 23: Mounting the lens sensor

3. Make sure that the cable tie lies in the groove of the sensor to prevent it from blocking the light.

Section 5 Connecting

5.1 Required tools

Only use a screwdriver and insert bits for Phillips (PH 1) cross-recessed head screws (M3.5) when handling CT/VT terminals (X2.1) of screw-compression type.

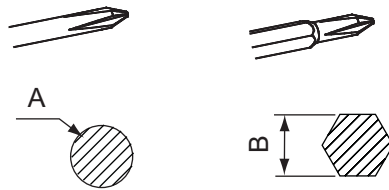

Figure 24: Screwdriver for CT/VT terminals of screw-compression type

A MAX \varnothing 5.5 mm

B MAX \varnothing 5 mm

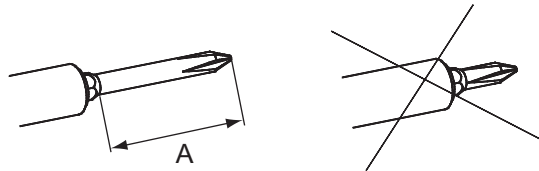

Figure 25: Insert bits for CT/VT terminals of screw-compression type

A MIN 15 mm

5.2 Connecting wires

All connections are made on the rear of the case. No soldering is needed. All the screw-compression type terminals are closed at the time of the delivery and needs to be opened before wires can be inserted.



Use fine wire in door mounting.



See the application manual for product-specific connection diagrams.

- Connect each signal connector (X100, X110 and X130) terminal with one 0.5...2.5 mm² wire or with two 0.5...1.0 mm² wires.
- Connect each ring-lug terminal for signal connector X120 with one of maximum 2.5 mm² wire.
- Connect each compression type terminal for CTs/VTs with one 0.5...6.0 mm² wire or with two of maximum 2.5 mm² wires.
- Connect terminals on the optional communication modules for connector X5 with one 0.08...1.5 mm² wire or with two of maximum 0.75 mm² wires.

5.2.1

Connecting ring-lug type wires

Ring-lug type insulated terminal can be used for signal connector X120. The maximum outside diameter for the M4 ring-lug type terminals is 9 mm.

5.3

Connecting protective earthing



The earth lead must be at least 6.0 mm². If the length of the earth lead is long, the cross section of the wire must be increased.



Use fine copper wire as the earth lead.

To connect a separate earth protection lead:

1. Loosen the protective earth screw to connect a separate earth protection lead.

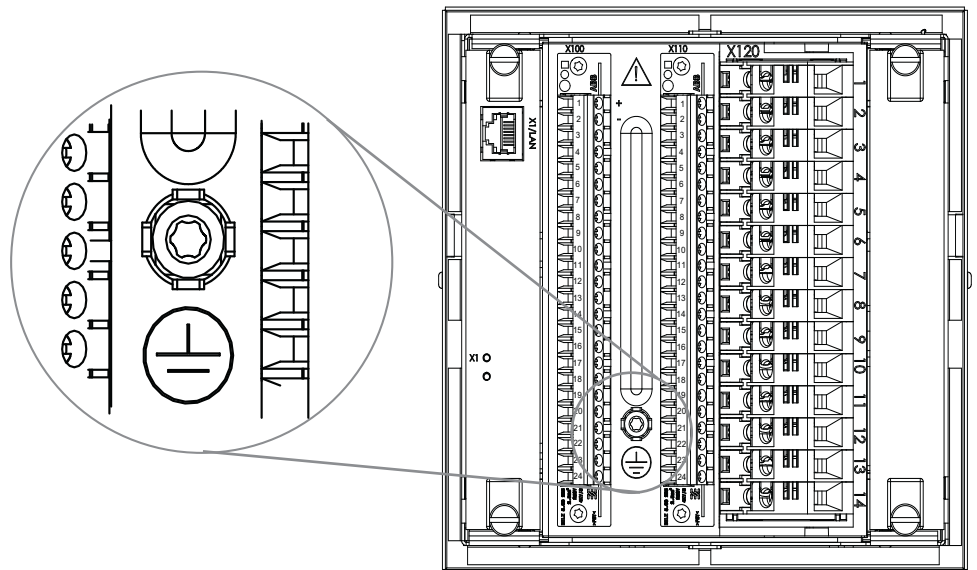

Figure 26: The protective earth screw is located between connectors X100 and X110



The earth lead should be as short as possible but notice that extra length is required for door mounting.



Each IED must have its own earth lead connected to the earth circuit connector.

2. Connect the earth lead to the earth bar.
Use either stripped wire screwed between a washer cup and the protective earth screw or a ring-lug.



Select a suitable ring-lug to fit under the M4 screw.

3. Tighten the protective earth screw.
4. Support the earth lead so that it cannot break or weaken.
Be aware of the mechanical, chemical and electrochemical environment.

5.4 Connecting analog signals

A connection diagram is needed to connect the analog signals.

When using the ring-lug type for CT/VT terminals.

1. Open the lid that covers the ring-lug fixing screw with the tip of a screwdriver. Every fixing screw has its own lid.
2. Remove the fixing screw.
3. Slide the screw through the terminal lug and screw it back on.
4. Close the lid.

5.4.1

Connecting current and voltage inputs

Connect the wires from the CTs/VTs to the correct device according to the phase order and the connection diagram. Each terminal for CTs/VTs is dimensioned for one 0.5...6.0 mm² wire or for two wires of maximum 2.5 mm².



See the specific card variants from the application manual.

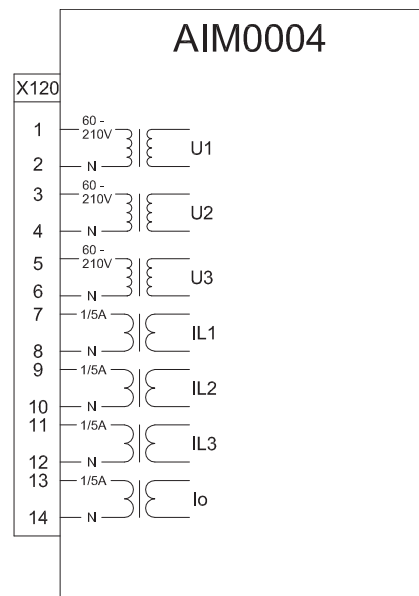

Figure 27: Example of AIM0004 card variant (4 I + 3 U with 1/5 A Io channel)

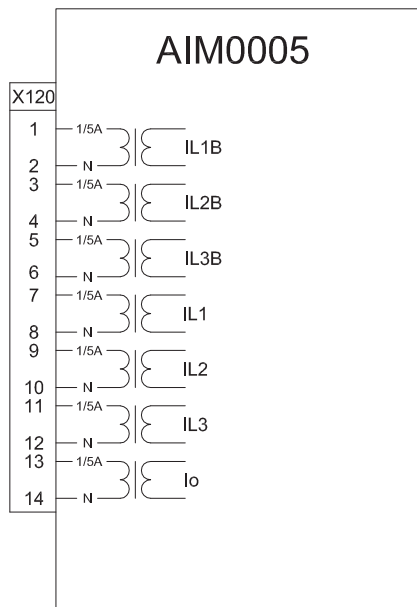

Figure 28: Example of AIM0005 card variant (7 I with 1/5 A Io channel)

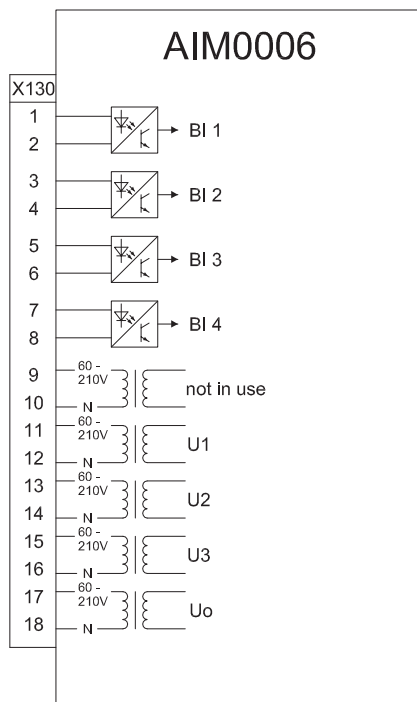

Figure 29: Example of AIM0006 card variant (5 U)

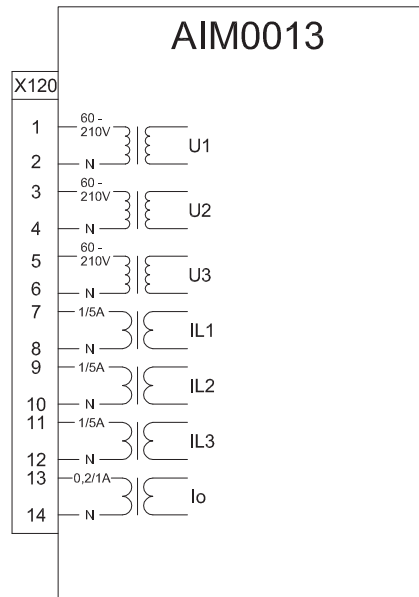

Figure 30: Example of AIM0013 card variant (4 I + 3 U with 0.2/1 A Io channel)

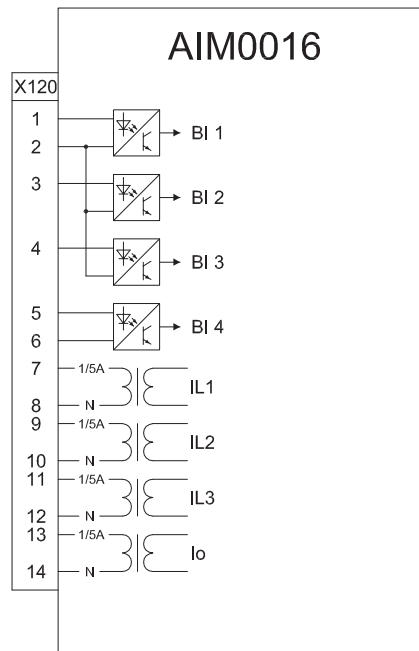

Figure 31: Example of AIM0016 card variant (4 I with 1/5 A Io channel)

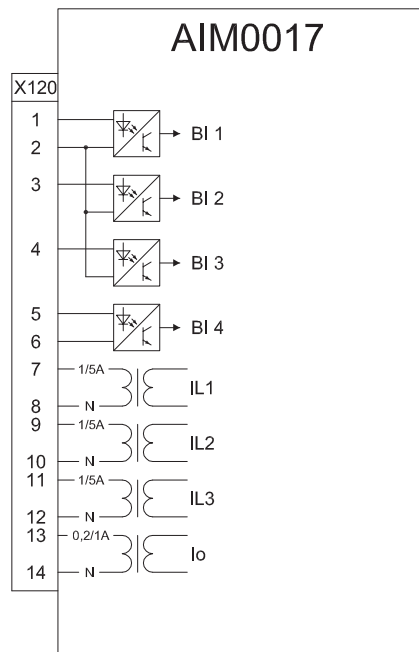

Figure 32: Example of AIM0017 card variant (4 I with 0.2/1 A Io channel)

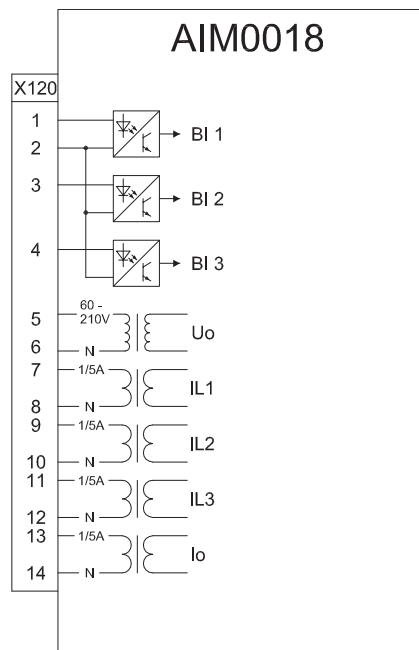

Figure 33: Example of AIM0018 card variant (4 I + Uo with 1/5 A Io channel)

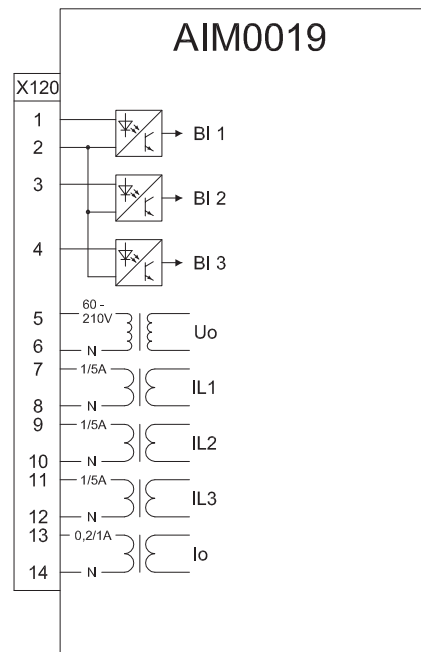

Figure 34: Example of AIM0019 card variant (4 I + U_o with 0.2/1 A I_o channel)

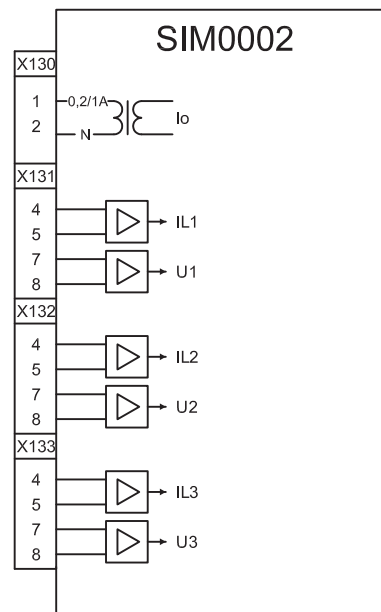

Figure 35: Example of SIM002 card variant (4 I + 3 U with 0.2/1 A I_o channel)

5.4.2 Connecting RTD and mA inputs

Connect the wires from the transducers to the correct device according to the connection diagram. Each terminal for RTDs and mA inputs is dimensioned for one 0.5...2.5 mm² wire or with two 0.5...1.0 mm² wires.



See the specific card variant from the application manual.



Connect the cable shields to the protective earth screw.

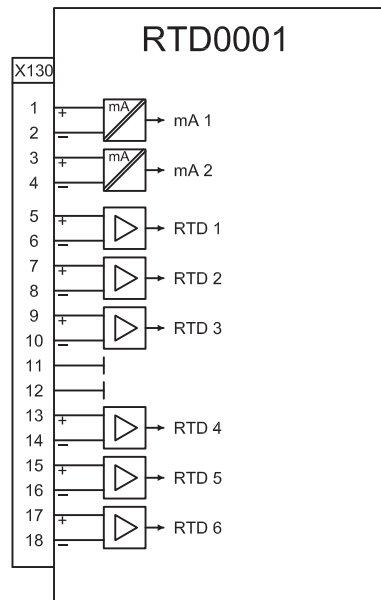

Figure 36: Example of RTD0001 card variant (6 RTD + 2 mA channel)

5.4.3 Connecting IED with a test switch

When the IED is used with a test switch, connect the current and voltage transformers directly to the switch.

5.5 Connecting power supply

The IED's auxiliary voltage is connected to terminals X100-1 and X100-2. The positive lead is connected to terminal X100-1. The permitted auxiliary voltage range of the IED is marked on top of the IED's LHMI.

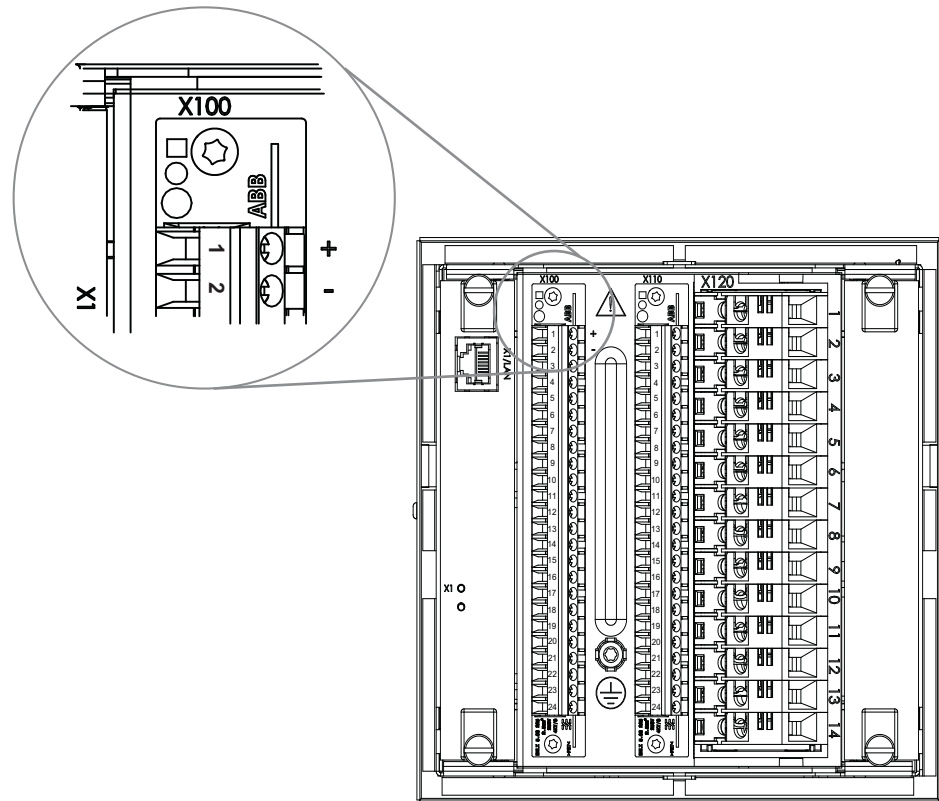

Figure 37: Connecting auxiliary voltage

5.6 Connecting communication

Before connecting communication, check that the HW module has the correct communication interfaces. The communication module is located on the left side of the IED when viewing the case from the rear.



See the technical manual for product-specific communication interfaces.

5.7 Energizing the IED

Before you connect the auxiliary power, check that the terminal strip is wired and placed correctly.

During the start-up all LEDs are lit for a short period.

- Green Ready LED starts to flash
- LCD lights up and IED start-up is displayed
- The main menu is displayed. A steady green Ready LED indicates a successful start-up.

If the IED detects a diagnostic error during start-up, the green Ready LED flashes and the internal fault code is displayed on the LCD.

Section 6 Removing, repairing and exchanging





6.1 Product lifecycle

In the product lifecycle, there is going to be a time to upgrade the IED to a next generation unit. Although this is not relevant until some 20 years after the installation, it is wise to already consider the product lifecycle when investing on the original product.

IED-specific options can be found from Retrofit Solutions Database on the Internet www.abb.com by following the links within ABB Service Guide or via ABB Product Guide from the product specific Service & Support sheet.

6.2 Checking IED information

The IED information includes detailed information about the device, such as version and serial number. The IED information is shown on the display for a few seconds when the device starts up. The same information is found also in the IED menu.

1. Select **Main Menu/Information**.
2. Select a submenu with  and .
3. Enter the selected submenu with .
4. Browse the information with  and .

The **Product identifiers** submenu contains product related information like product type, serial number, order number, production date, configuration name, SW version, SW date and HW revision.

The **Site identifiers** submenu contains information about the site where the IED has been installed.

The **HW modules** submenu contains information about the HW modules.

The **System identifiers** submenu contains the unique Technical key which cannot be changed.

6.3 Removing the IED

1. Turn off the power.
2. Detach the plug-in unit from the case.
3. Disconnect the wiring.
4. Loosen the four M5 fixing screws.

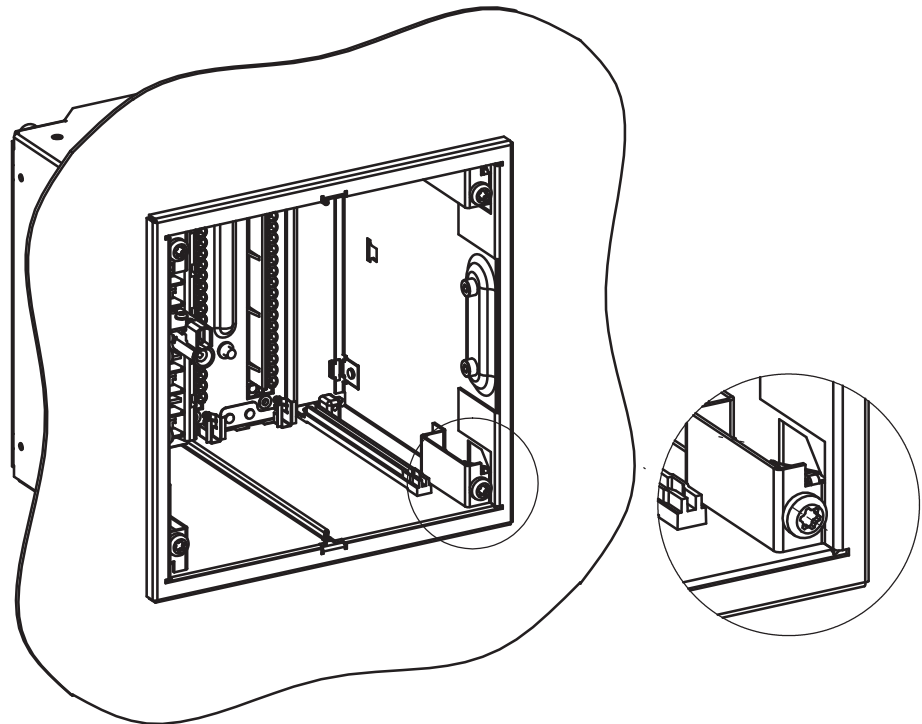

5. Detach the case from the panel cut-out.

6.4 Sending the IED for repair

In case of product problems, contact the nearest ABB or representative for consultation and instructions.

6.5 Exchanging the IED

To exchange the IED with another identical unit, remove the IED and install the new one. The exchangeable units can be found from the PartsOnLine system, see www.abb.com/partsonline. Use of PartsOnLine requires user registration.

To exchange an IED to a different unit, change the case and connect the wires.



Check with your local ABB if the IED can be upgraded.

Section 7 Technical data

7.1 Case and HMI display variants

7.1.1 Front side of the IED

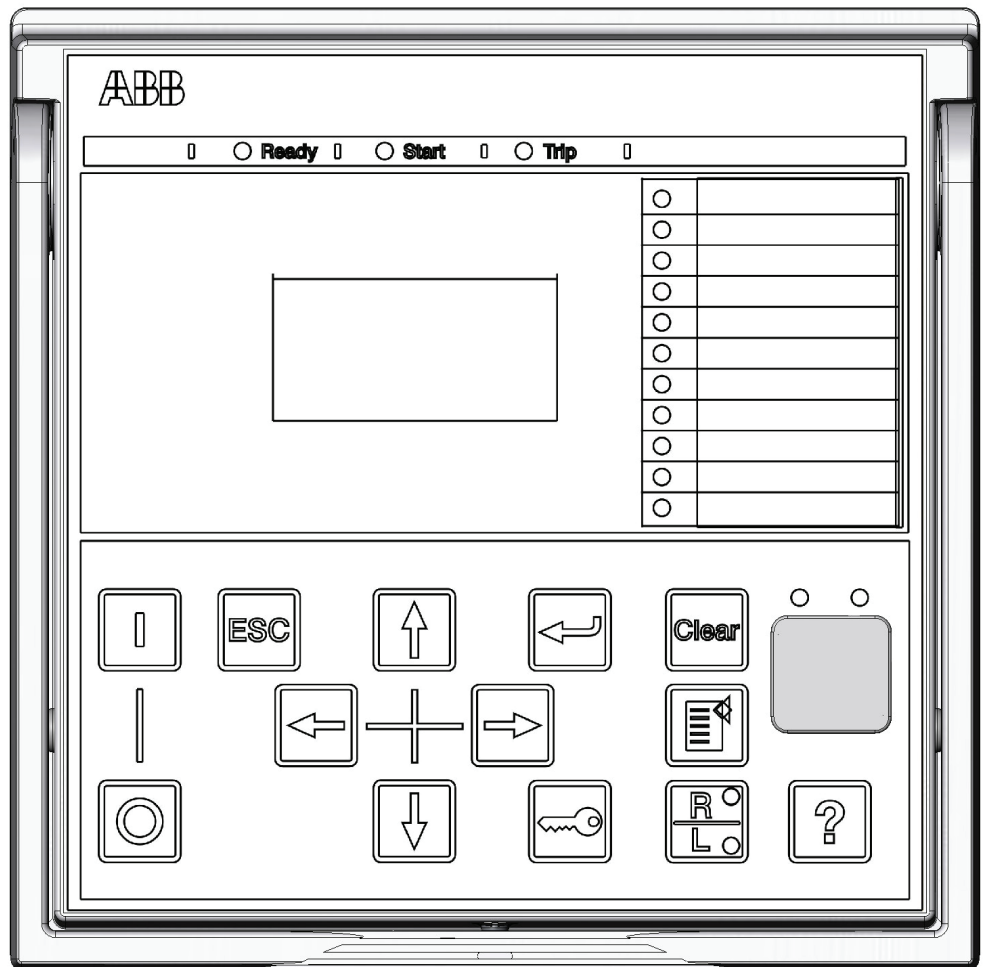

Figure 38: Small display

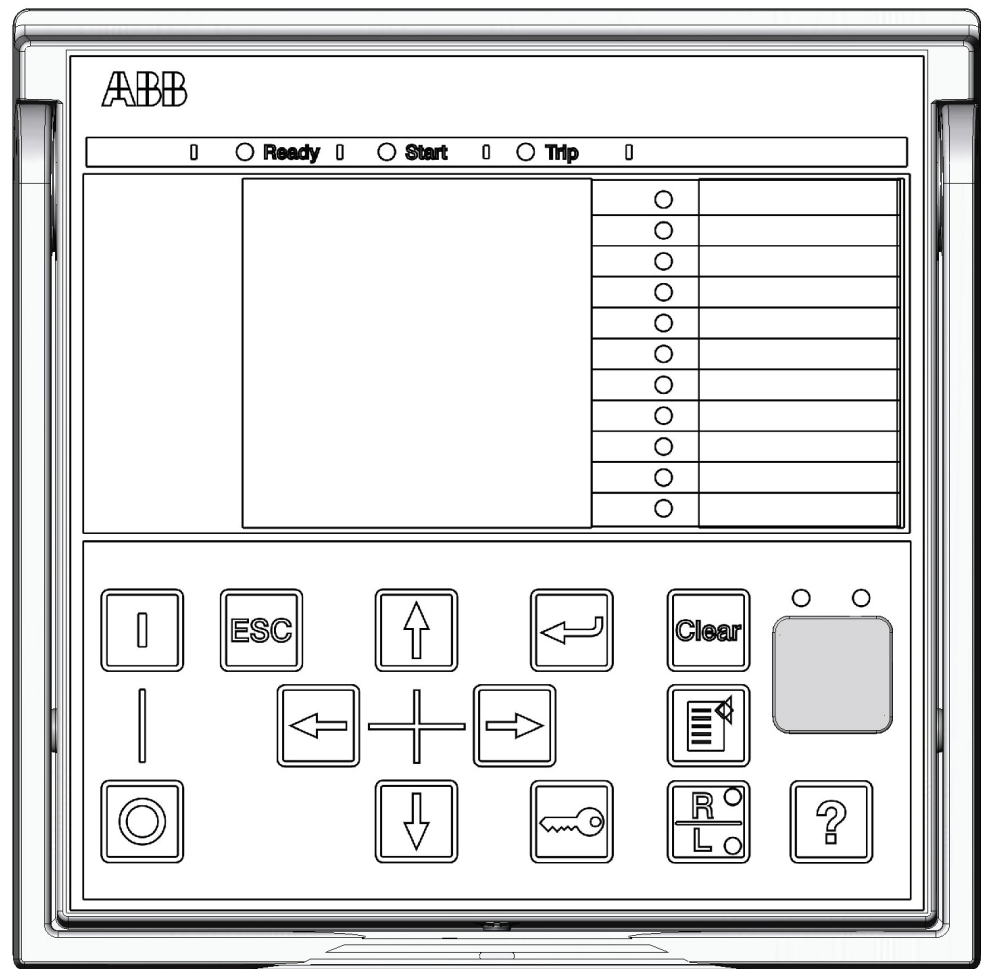

Figure 39: Large display

Table 3: Small display

Character size ¹⁾	Rows in the view	Characters per row
Small, mono-spaced (6x12 pixels)	5	20
Large, variable width (13x14 pixels)	4	8 or more

1) Depending on the selected language

Table 4: Large display

Character size ¹⁾	Rows in the view	Characters per row
Small, mono-spaced (6x12 pixels)	10	20
Large, variable width (13x14 pixels)	8	8 or more

1) Depending on the selected language

7.1.2 Rear side of the IED

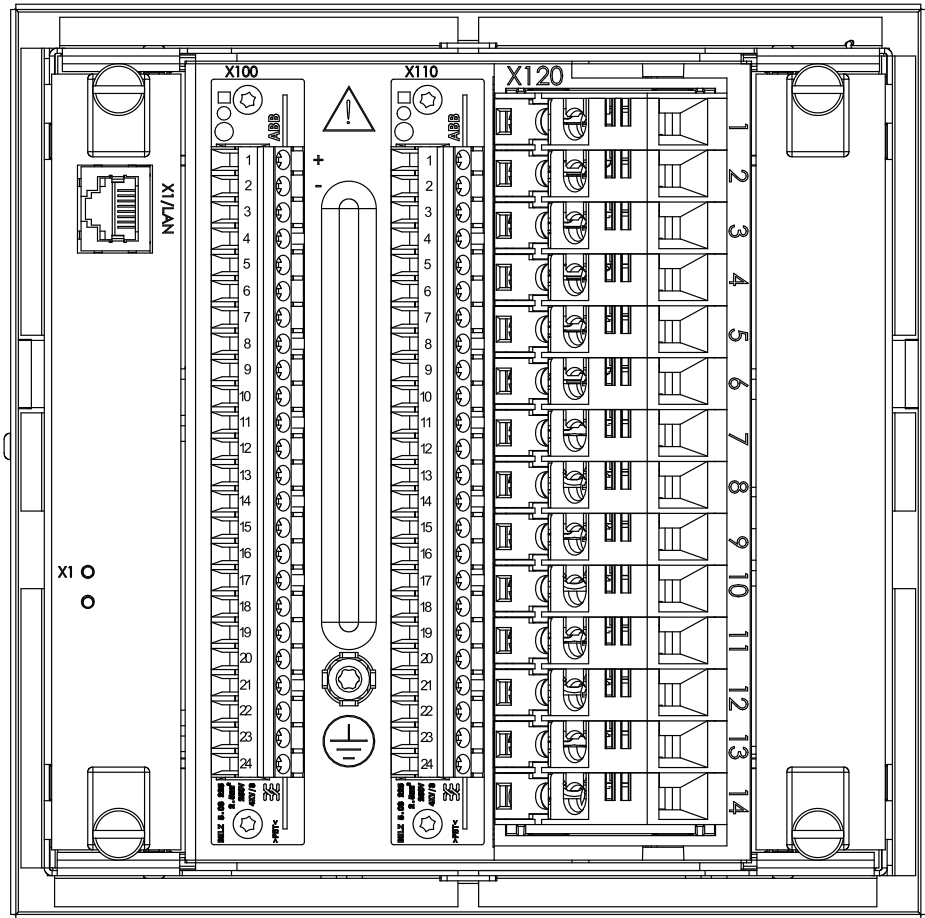

Figure 40: Rear view of an 615 series IED with communication module

7.2 Dimensions

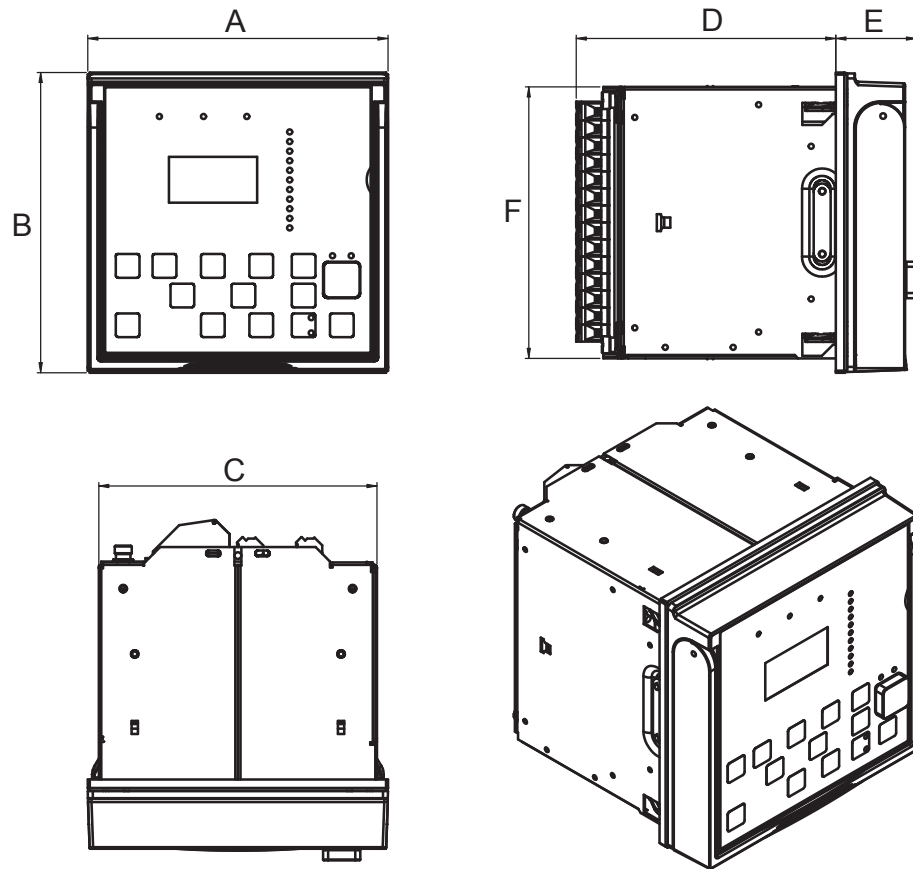

Figure 41: 615 series main dimensions

- A 177 mm
- B 177 mm (4U)
- C 164 mm
- D 153 mm
- E 48 mm
- F 160 mm

Table 5: Dimensions

Description	Value	
Width	frame	177 mm
	case	164 mm
Height	frame	177 mm (4U)
	case	160 mm
Table continues on next page		

Description	Value	
Depth	201 mm (153 + 48 mm)	
Weight	complete IED	4.1 kg
	plug-in unit only	2.1 kg

7.3

Enclosure class

Table 6: Degree of protection of flush-mounted IED

Description	Value
Front side	IP 54
Rear side, connection terminals	IP 20

Section 8 Accessories and ordering data

Table 7: *Cables*

Item	Order number
Cable for optical sensors for arc protection 1.5 m	1MRS120534-1.5
Cable for optical sensors for arc protection 3.0 m	1MRS120534-3.0
Cable for optical sensors for arc protection 5.0 m	1MRS120534-5.0

Table 8: *Mounting accessories*

Item	Order number
Semi-flush mounting kit	1MRS050696
Wall mounting kit	1MRS050697
Inclined semi-flush mounting kit	1MRS050831
19" rack mounting kit with cut-out for one IED	1MRS050694
19" rack mounting kit with cut-out for two IEDs	1MRS050695
Mounting bracket for one IED with test switch RTXP in 4U Combiflex (RHGT 19" variant C)	2RCA022642P0001
Mounting bracket for one IED in 4U Combiflex (RHGT 19" variant C)	2RCA022643P0001
19" rack mounting kit for one IED and one RTXP18 test switch (the test switch is not included in the delivery)	2RCA021952A0003
19" rack mounting kit for one IED and one RTXP24 test switch (the test switch is not included in the delivery)	2RCA022561A0003

Section 9 Glossary

CT	Current transformer
EMC	Electromagnetic compatibility
HMI	Human-machine interface
IEC	International Electrotechnical Commission
IEC 61850	International standard for substation communication and modelling
IED	Intelligent electronic device
LCD	Liquid crystal display
LCP	Liquid crystal polymer
LED	Light-emitting diode
LHMI	Local human-machine interface
PA	Polyamide
PBT	Polybutylene terephthalate
PC	Personal computer; Polycarbonate
PCM600	Protection and Control IED Manager
RoHS	Restriction of the use of certain hazardous substances in electrical and electronic equipment
VT	Voltage transformer

Contact us

ABB Oy

Distribution Automation

P.O. Box 699

FI-65101 VAASA, Finland

Phone +358 10 22 11

Fax +358 10 22 41094

www.abb.com/substationautomation