

NGC 8209

Natural gas chromatograph

The NGC 8209, the C9+ natural gas chromatograph performs on-site natural gas analysis and heating value computation using an extended analysis.



Benefits

On-line chromatograph techniques are used to provide N2 through C6+ data while a third column train is used to separate the C6+ fraction. The NGC 8209 utilizes the modular and scaleable XSeries software framework to integrate data from a third analysis train into the standard C6+ analysis of the Natural Gas. The extra chromatographic information is provided as NC6's, NC7's, NC8's and C9+ to provide this "extended analysis". Heating value (CV), Wobbe, Relative Density (SG) and other calculations are performed using the combined analysis data in a similar manner to the NGC 8206. Hydrocarbon Dew Point (HCDP) and Speed of Sound (SOS) calculations are available options. A single computer controller seamlessly processes all this data for various outputs. It also handles the stream switching and the timing for the sample. Incorporating a state-of-the-art built-in 32 bit digital controller, three electronic carrier pressure regulators, oven-mounted sensors and advanced low-noise digital electronics, the NGC 8209 performs with unparalleled repeatability and sensitivity. The NGC 8209 provides custody transfer/metrology quality Chromatography for heating value and composition measurement. It provides the user with a GC that is lower in cost, easier to install and commission, and less costly to operate.

Standard features

Modular design includes:

- Three analysis trains, two for N2 through C6+ and one for the C6 through C9+
- Modular software – application based plug-in software modules
- Manifold modules
- Analysis sections contain stream selection solenoids, temperature and pressure regulation, 32 bit digital detector electronics, replaceable column / valve modules and a low power 32 bit digital controller, using Windows CE® (internal to GC unit)
- Microsoft® Windows® based man-machine interface software (PCCU)
- Lithium battery-backed RAM
- Two remote serial digital communications ports; one local port (USB Client)
- One USB Host and one Ethernet port
- Comprehensive diagnostics and wizards available to users
- Three-level security for user access control (Read only, Operate and Read/Write)
- Audit-quality historical data; date and time stamped
- Standard Calculations;
 - US and SI:
 - Heating value
 - Relative density
 - GPM
 - Wobbe
 - Methane-number

NGC 8209

Natural gas chromatograph

Standard features

- Auto-start cycle automatically after power failure:
 - Stabilizes oven temperature
 - Confirms modules' functions
 - Checks for operational alarms
 - Returns to pipeline streams
- Operational alarms available with each analysis cycle.
- Detectors - constant temperature, glass encapsulated thermister beads for rugged service and long life. Will not burn out on loss of carrier.
- 10 port valves have no moving metal parts in each analysis unit
- Low utility usage - low-power, low-carrier, no instrument air required
- On demand or scheduled automatic calibration and diagnostics
- Continuous monitoring for alarms
- On board digital 1/4 VGA display with multiple screen access

Standard options

- Sample Conditioning Modules
- Calculation packages (eg, Hydrocarbon Dew point via SRK and Peng-Robinson, including: 4 pressures and the Cricondentherm)
- SD memory cards for raw chromatogram storage
- Feed-Through heater for colder operations or high dew point gas sampling

Description

The NGC 8209 analyzes each sample utilizing established chromatographic techniques. The resulting information consists of mole percent values for the following:

Component	Symbol	Range (Mol %)
Nitrogen	N2	0.01 - 100
Methane	C1	0.01 - 100
Carbon Dioxide	CO2	0.01 - 100
Ethane	C2	0.01 - 50
Propane	C3	0.005 - 100
Isobutane	IC4	0.005 - 15
Butane	NC4	0.005 - 15
NeoPentane	Neo	0.005 - 10
IsoPentane	IC5	0.005 - 10
Pentane	NC5	0.005 - 10
Hexanes	C6's	0.005 - 1
Heptanes	C7's	0.005 - 1
Octanes	C8's	0.005 - 0.5
Nonanes +	C9+	0.005 - 0.5

Using process chromatographic techniques, the columns are back flushed so that the NGC 8209 measures a C3+, C6+, and a C9+ peak. The rest of the analyzed components are carried through the columns and the detectors where integration takes place. Composition results and calculated values are then stored in memory and communicated to other devices as needed. All of these values as well as composition are available on various Modbus communication protocols.

Installation

The NGC 8209 is a weatherproof device designed for installation "on the pipe" near to the sampling point. This means it is acceptable to mount outside - in a temperature range of 0°F to 130°F (-18°C to 55°C), onto a pipeline with 2" to 12" pipe sizes or with an optional pole mount configuration. A cold weather enclosure is also available if ambient conditions are below either the sampled gas dew point or the operational specifications of the unit. If ambient temperatures are expected to exceed 130°F (55°C) we recommend installing a sun shade.

Sample conditioning system

The integral stream selector for the NGC 8209 allows sampling up to four (4) different natural gas streams. Up to two of these sample streams can be designated as the "calibration/validation sample". Optional sample conditioning modules are available to address natural gas streams that need additional filtering and "speed loops" to reduce sample transport lag times.

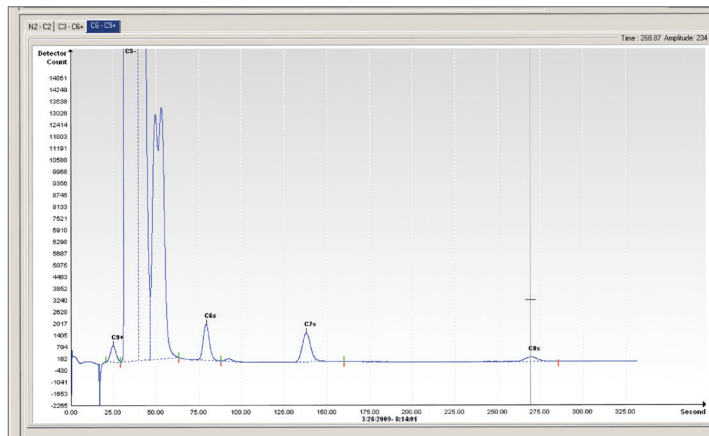
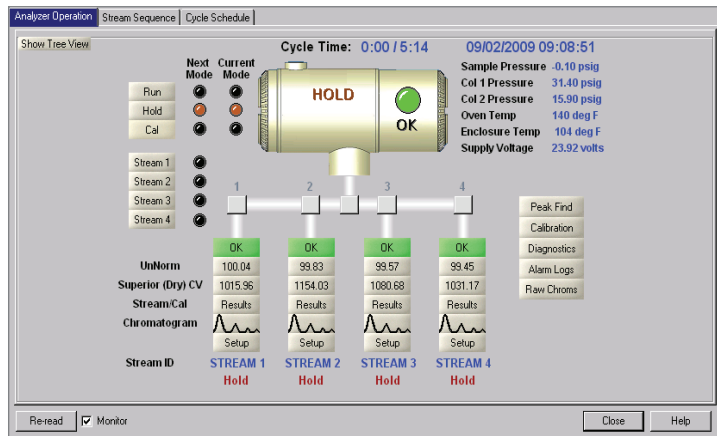

Operator interfaces

Functional setup and operation of the NGC 8209 is accomplished by using a graphical user interface software package called PCCU (supplied with each unit) operating on a laptop PC in a Microsoft® Windows® environment. PCCU, software designed specifically for the NGC 8209, provides a powerful tool for operations, diagnostics, and downstream data handling. The PC can be directly connected to the NGC 8209 via an RS-232, USB, or Ethernet connection, or indirectly by remote telemetry (phone modem, radio, cell phone, satellite, etc.). The user is prompted through push-buttons, drop-down boxes, wizards, and dialog boxes for setup, operations, data collection and monitoring.

In addition, the unit has a ¼ VGA interactive display screen allowing the user access to basic analysis data and perform basic operations.

Maintenance

The NGC 8209 was designed from the ground up to be maintained by personnel with little or no prior knowledge of Gas Chromatography. Both hardware and software are designed to provide low maintenance through easily replaceable electro-mechanical modules such as:

- NGC Termination Panel
- NGC Analytical Module, an easily removable
- Chromatograph subassembly, containing;
 - NGC Manifold
 - Stream Selector Solenoid Valves
 - GC valve assembly
 - Multiple Electronic Carrier
 - Pressure Regulator Valves
 - Chromatograph Pilot Valve
 - NGC Analytical Processor
- NGC Feed-Through (with optional heater)
- Sample Conditioning Module (SCM) (optional)
- NGC Controller, (32 bit Processor)

NGC 8209

Natural gas chromatograph

Other Maintenance Support Features

- Intuitive Local Operator Interface (PCCU) running Microsoft® Windows®
- Diagnostic software and wizards (future) for maintenance
- Digitized detector output (chromatogram) to PCCU
- Remote or local operation of PCCU
- Quick Start guide, Start up manual and Start up video (future)

Historical data

The NGC 8209 is designed to retain historical data. This data can be used for custody transfer needs, verify transmitter operation over time, and provide a limited data backup for communication link reliability. The user is allowed to configure the period of the data retained by the NGC 8209 via the Operator Interface.

The default* memory configuration provides the most recent 480 analysis cycles containing:

- Normalized components
- Un-normalized components
- Ideal Btu/CV
- Real Btu (wet and dry) / CV (superior and inferior)
- Relative Density (Specific Gravity)
- Density
- GPM
- Wobbe index
- HCDP
- Alarms

Stream averages for the (default*) 840 last hours, 35 last days and the most recent last month analyses. Operational Parameters for the (default*) last 480 cycles (Diagnostics Report):

- Selected peak times
- Selected peak areas
- Ideal Btu/CV
- Carrier regulator pressure
- Oven temperature
- Ambient temperature
- Sample pressure
- Detector noise values
- Detector balance values
- Audit logs (Default*)
- Last 480 alarms
- Last 480 events

Data retained by the NGC 8209 can be collected via a remote communication link or by the laptop PC local operator interface PCCU.

Available accessories

- 120/240 VAC to 12VDC power supply
- 120/240 VAC to 24VDC power supply
- Pole or pipeline mounting kits
- Cold weather enclosure (also available in pipe mount configuration)
- Cold weather thermal jacket (future)
- Modular Sample System Conditioner options for
 - Non-pipeline quality natural gas sample
 - Up to 450 LC/min speed loops
- Probes
 - Temperature compensating fixed
 - Temperature compensating retractable
 - Liquid rejection
 - Electrically heated, retractable
- Regulators (carrier and calibration blend)
- Start-up calibration/validation gas sample ($\pm 2\%$ blend)
- Carrier Gas: 99.995% pure helium (chromatographic grade)
- SD memory card, various up to 1Gig
- Export crating
- Tool kit
- Welker and A+ Corp. liquid shut-offs
- Various maintenance kits
- Customer Factory Acceptance Test (FAT)

(Default*) The default memory configuration will provide for the data storage above. User may reallocate the memory that is available.

Specifications

- Meet or exceeds GPA 2261-99 for linearity
- Four stream capability. Manual calibration required with 4 sample streams.
- Single auto calibration stream and 3 sample streams, or a max of 2 auto calibration streams and 2 sample streams.

Note on linearity of C6 through C9+

Extensive linearity testing is usually done to prove the design of a GC. This has been done for the NGC 8206 and the results can be obtained in another datasheet. It is, however, doubtful that the same data could be obtained for the “extended analysis” fraction, that is, the components beyond C6 and up to C9+. The reasons for this are as follows:

- The wide concentration ranges needed to produce the linearity data will themselves prevent building stable calibration blends. When blends with more than 1000 ppm (0.1 Mol %) of any of the C6, C7, C8, and C9+ components are added to a blend, the Hydrocarbon Dew Point (HDP) of that blend will tend to make it become a liquid unless kept and sampled at a high temperature. Greater than 1000 ppm of C6, C7, C8, or C9 increases the HDP to such a point the mixture would have to be heated beyond 120F-140F to keep the mixture a gas. This increases the difficulty of keeping or sampling from the needed blends.
- The accuracy of a gravimetric calibration blend at these very low mol % levels drops off significantly due to the very small weights of the gases added. This leads to a much greater error in the resulting mol % of each component and therefore in the accuracy of the blend. This inaccuracy tends to make the generation of the detector response curve meaningless.

However, the usable linear range of the detectors is quite wide at the reasonable operating concentrations found in these heavier fractions in comparison to the possible variations in blend concentrations. So the NGC linearity will likely exceed the real world requirements.

Specifications:	
Dimensions	6.75" diameter x 16" long x 9.00" tall (17.1 cm x 40.6 cm x 22.9 cm)
Weight	Approximately 28 lb. (12.7 Kg) Shipping Weight: 47 lb. (21.3 Kg)
Weatherproof construction	CSA Type 4X, IECEx IP56, ATEX Type 4X (IP66 Equivalent), aluminum alloy with white polyester powder coating.
Carrier gas	Helium 1 large helium bottle should last between 9 months to 1 year
Analysis time	Approximately five (5) minutes; cycles may be scheduled by user
Repeatability	± 0.125 Btu @ 1,000 Btu (± 0.0125%) @ ambient ± 0.25 Btu @ 1,000 Btu (± 0.025%) over temperature range
Temperature range (storage)	-22°F to +140°F (-30°C to 60°C)
Temperature range (normal)	0°F to 130°F (-18°C to 55°C)
with cold weather enclosure	-40°F to +130°F (-40°C to 55°C)
Moisture	95% Relative Humidity Non-Condensing
Supply voltage	10.5 to 16 Vdc Optional: 21 to 28 Vdc
Power consumption	Nominal operation @ 0°F (-18°C) = 7 Watts; (650 mA) Start up @ less than 3 amps (45 Watts @ 15 VDC)
Certifications	NEC & CEC Class I, Div. 1, Groups B, C and D, T6; CFR 47, Part 15: IECEx Exd IIB + H2 T6; Class I Zone 1: INMETRO Exd 11B + H2 T6; Class 1 Zone 1:  II 2G : Ex d, IIB+H2 T6; Class I, Zone 1: EMC - EMI/RFI: EN 55022, EN 61000-6-1, EN 61000-4-2, 4-3, 4-4, 4-6, 4-8: CISPR 22-2004
Heating value calculations supported	GPA 2172 ISO 6976 ASTM 3588
Calculations per compressibility calculation	AGA 8 ISO 12213 NX-19
Analysis standards compliant with	GPA 2261 ISO 6974 ASTM 1945
Miscellaneous type approvals	Industry Canada, MI (Netherlands), BRML (Romania), China Weight & Measures
Communications supported	Two serial digital ports, software selectable for RS-232, RS-485, or RS-422. One USB MMI (RS-232 or USB). Optional USB hub (host and client) and Ethernet ports.
Protocols supported	Totalflow Remote / Local MMI Totalflow / TCP Modbus / TCP Server Modbus / TCP Client, Modbus ASCII or RTU (Modicon, WordSwap, or Danalyzer)

NGC 8209

Installation dimensions

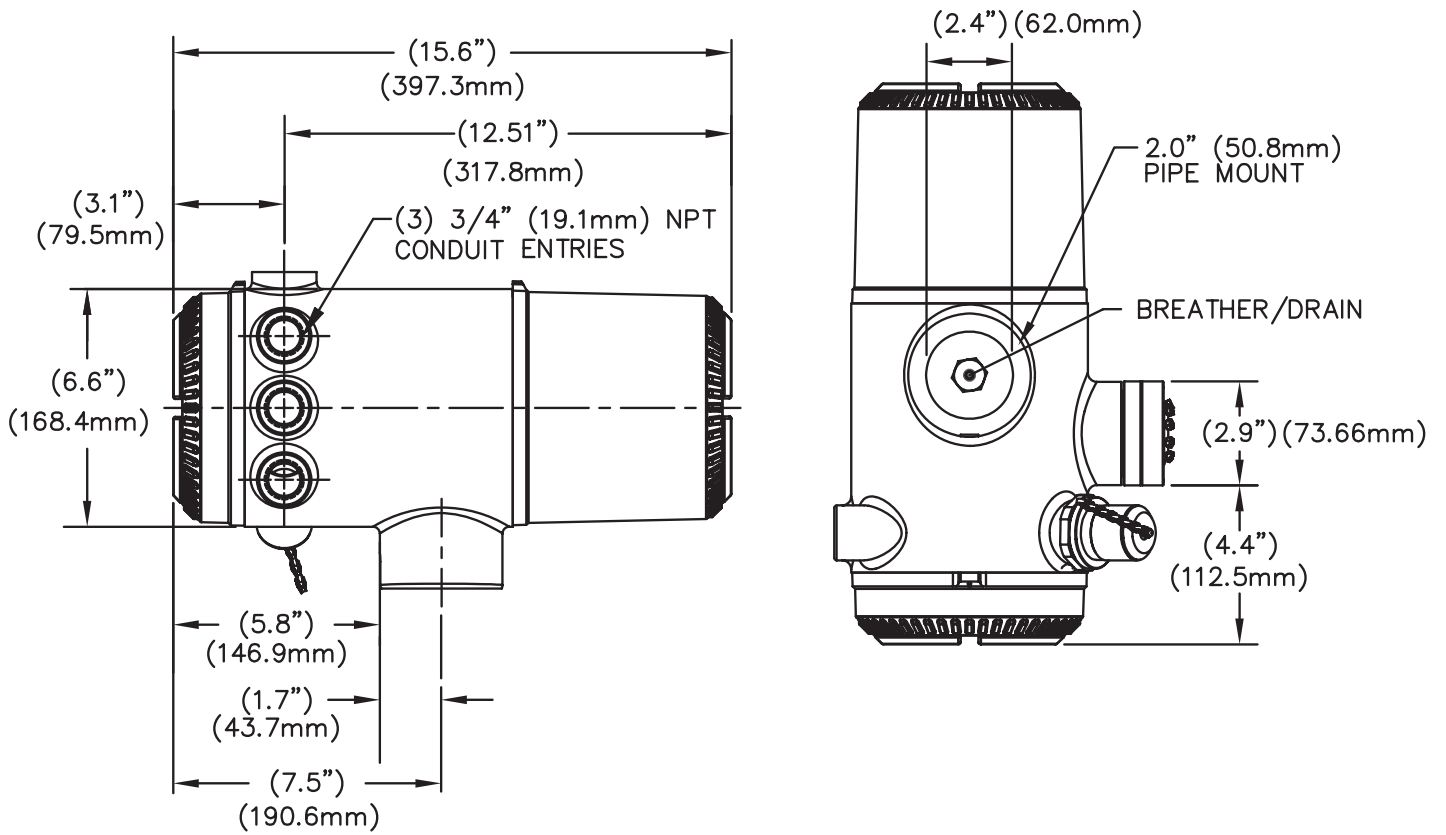

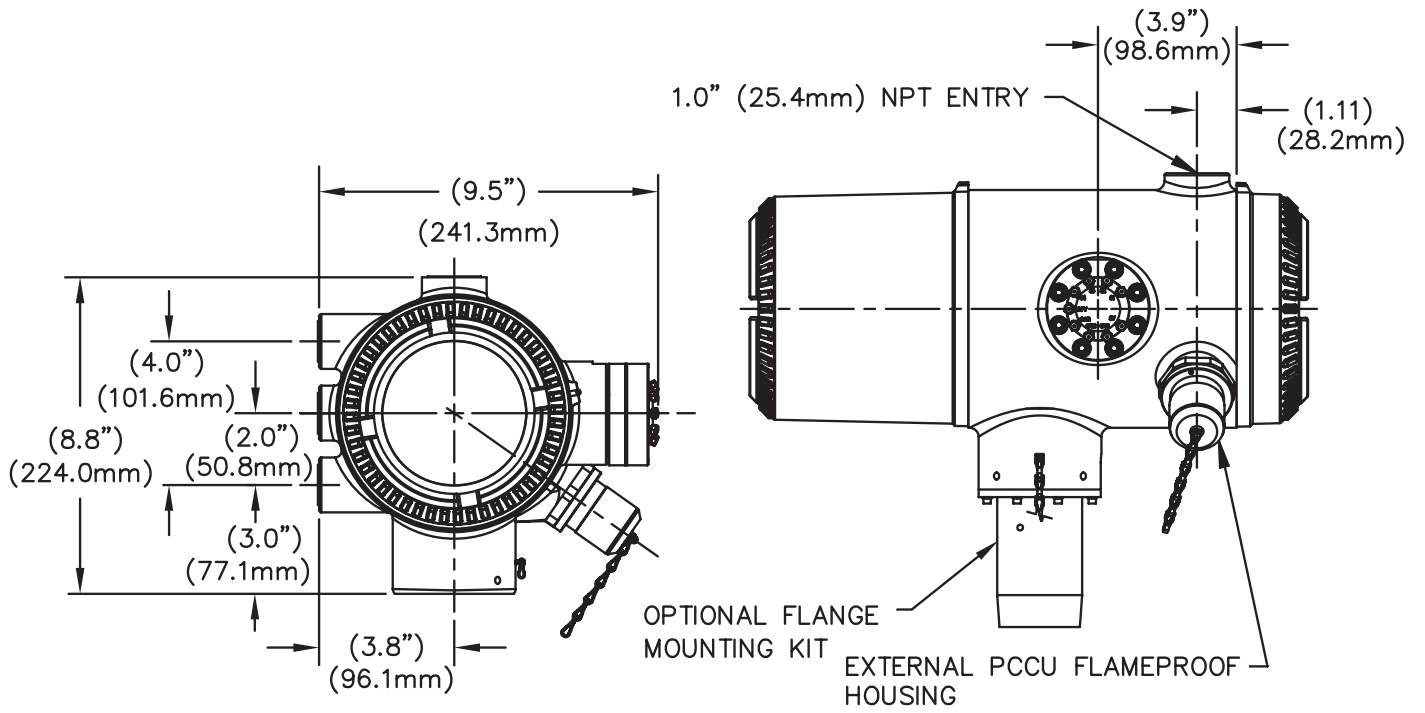

Contact us

ABB Inc.
Measurement Products
Main Office

7051 Industrial Boulevard
Bartlesville, OK 74006
Phone: +1 918 338 4888
+1 800 341 3009
Fax: +1 918 338 4699

ABB Inc.
Measurement Products

3700 W Sam Houston Parkway South,
Ste. 600
Houston, TX 77042
Phone: +1 713 587 8000
Fax: +1 713 266 4335

3900 S. County Rd. 1290
Odessa, TX 79765
Phone: +1 432 563 5144
Fax: +1 432 563 8043

ABB Inc.
Measurement Products

2 Acee Dr.
Natrona Heights, PA 15065
Phone: +1 724 295 6100
Fax: +1 724 295 6560

ABB Inc.
Measurement Products

4300 Stine Rd.
Ste. 405-407
Bakersfield, CA 93313
Phone: +1 661 833 2030
Fax: +1 661 833 2034

ABB Inc.
Measurement Products

2705 Centennial
Liberal, KS 67901
Phone: +1 620 626 4352
Fax: +1 620 626 4354

www.abb.com/totalflow

Note

We reserve the right to make technical changes or modify the contents of this document without prior notice. With regard to purchase orders, the agreed particulars shall prevail. ABB does not accept any responsibility whatsoever for potential errors or possible lack of information in this document.

We reserve all rights in this document and in the subject matter and illustrations contained therein. Any reproduction, disclosure to third parties or utilization of its contents - in whole or in parts - is forbidden without prior written consent of ABB.

Copyright© 2011 ABB
All rights reserved