

MEDIUM VOLTAGE PRODUCTS

VM1-T

Vacuum circuit breaker



Table of contents

1. Summary	3
2. Structure	4
3. Function	6
4. Despatch and storage	9
5. Installation and mounting of the breaker	10
6. Commissioning / Operation	11
7. Maintenance	14
8. Application of the X-ray regulations	20
9. Figures	21
10. Technical data	30
11. Comparison of designations to IEC 61346-1 / 61346-2, IEC 81346-1 / 81346-2 and VDE-DIN 40719 Part 2	42

For your safety!

That's why our instruction manual begins with these recommendations:

- Only install switchgear and/or switchboards in enclosed rooms suitable for electrical equipment.
- Ensure that installation, operation and maintenance are carried out by specialist electricians only.
- Comply in full with the legally recognized standards (DIN VDE/IEC), the connection conditions of the local electrical utility and the applicable safety at work regulations.
- Observe the relevant information in the instruction manual for all actions involving switchgear and switchboards.



Danger

Pay special attention to the hazard notes in the instruction manual marked with this warning symbol.

- Make sure that under operation condition of the switchgear or switchboard the specified data are not exceeded.
- Keep the instruction manual accessible to all persons concerned with installation, operation and maintenance.
- The user's personnel are to act responsibly in all matters affecting safety at work and the correct handling of the switchgear.
- Always observe the five safety rules set out in EN 50110 on establishing and securing the off-circuit condition at the place of work for the duration of work on the switchgear.
 - Isolate
 - Secure to prevent reconnection
 - Check the off-circuit condition
 - Earth and short-circuit
 - Cover the guard off adjacent live parts

If you have any further questions on this instruction manual, the members of our field organization will be pleased to provide the required information.

Contents

	Page		Page
1. Summary	3	7. Maintenance	14
1.1 General	3	7.1 General	14
1.2 Standards and specifications	3	7.2 Inspection and functional testing	14
1.2.1 Switchgear manufacture	3	7.2.1 Circuit breaker in general	14
1.2.2 Installation and operation	3	7.2.2 Magnetic actuator operating mechanism	15
1.3 Operating conditions	3	7.2.3 Withdrawable part	15
1.3.1 Normal operating conditions	3	7.3 Servicing	15
1.3.2 Special operating conditions	3	7.3.1 Circuit breaker in general	15
2. Structure	4	7.3.2 Magnetic actuator operating mechanism	15
2.1 Structure of the operating mechanism	4	7.3.3 Breaker pole	16
2.1.1 Structure of the control module	4	7.4 Repair	16
2.1.2 Storage capacitor	4	7.4.1 Repair of surface damage	16
2.1.3 Sensor system	4	7.4.2 Replacement of components	16
2.2 Structure of the breaker poles	5	7.5 Tests on withdrawable parts with VM1-T type circuit breakers	17
2.3 Basic structure of the circuit breaker on withdrawable part	5	7.5.1 Motor-driven withdrawable parts	17
3. Function	6	7.5.2 Checking the auxiliary switch settings on withdrawable parts	17
3.1 Function of the circuit breaker operating mechanism	6	7.5.3 Checking the direction of rotation of the travel motors on motor-driven withdrawable parts	18
3.1.1 Magnetic actuator	6	7.5.4 Checking of interlock conditions	18
3.1.2 Opening and closing procedure	6	7.6 Spare parts, auxiliary materials, lubricants	18
3.1.3 Reclosing sequence	6	7.6.1 Spare parts	18
3.1.4 Circuit breaker controller	6	7.6.2 Auxiliary materials and lubricants	19
3.1.5 "READY" lamp	7	8. Application of the X-ray regulations	20
3.1.6 Blocking magnet -RL2	7	9. Figures	21
3.2 Circuit diagrams for circuit breaker withdrawable assemblies	7	10. Technical data	30
3.3 Quenching principle of the vacuum interrupter	8	10.1 Technical data, general	30
3.4 Interlocks	8	10.1.1 Technical data Control electronics	30
3.4.1 Interlocks/protection against maloperation (for C.B. on withdrawable part)	8	10.1.2 Technical data AC/DC converter	30
3.4.2 Interlocks for VM1-T withdrawable parts	8	10.1.3 Permissible number of vacuum interrupter operating cycles	31
3.4.3 Interlocks when non-original withdrawable assemblies are used	8	10.2 Technical data	33
4. Despatch and storage	9	10.2.1 Performance data and weights	33
4.1 Condition on delivery	9	10.2.2 Dimensions	34
4.2 Packaging	9	10.3 Technical data	37
4.3 Transport	9	Circuit breakers on withdrawable part	37
4.4 Delivery	9	10.3.1 Performance data and weights	37
4.5 Intermediate storage	9	10.3.2 Dimensional drawings	38
5. Installation and mounting of the breaker	10	10.3.3 Wiring diagrams for C.B. on withdrawable part	40
6. Commissioning / Operation	11	11. Comparison of designations to IEC 61346-1 / 61346-2, IEC 81346-1 / 81346-2 and VDE-DIN 40719 Part 2	42
6.1 Note on safety at work	11		
6.2 Preparatory activities	11		
6.3 Earthing	11		
6.4 Movement of the withdrawable breaker part	12		
6.4.1 Manual insertion from the test/disconnected position into the service position	12		
6.4.2 Manual withdrawal from the service position into the test/disconnected position	12		
6.4.3 Motor-driven movement of the withdrawable part	12		
6.4.4 Withdrawal from the test/disconnected position onto the service truck	12		
6.4.5 Insertion from the service truck into the test/disconnected position	13		
6.5 Operation of the circuit breaker	13		

1. Summary

1.1 General

The vacuum circuit breakers of type VM1-T are intended for indoor installation in air-insulated switchgear. They have a switching capacity capable of handling the loads occurring at start-up and shutdown of equipment and plant units both in normal and in fault state.

Vacuum circuit breakers have particular advantages for use in systems where the switching frequency in the operating current range is high, and/or where a certain number of short circuit breaking operations have to be reckoned with. Vacuum circuit breakers of type VM1-T are prepared for auto-reclosing operations and are notable for their especially high operational reliability and extremely long service life with complete freedom from maintenance.

The vacuum circuit breakers of type VM1-T in column design can be supplied both as individual units for stationary mounting and mounted on trucks. Their basic structure is shown in section "Technical data".

1.2 Standards and specifications

1.2.1 Switchgear manufacture

The switchgear complies with the following specifications in accordance with DIN VDE and the relevant IEC publications:

- VDE 0670, part 1000 and IEC 60694
- VDE 0671, part 100 and IEC 62271-100

1.2.2 Installation and operation

The relevant specifications are to be taken into account during installation and operation, particularly:

- DIN VDE 0101, Power installations exceeding AC 1 kV
- DIN VDE 0100-410, Erection of power installations up to 1000 V, protective measures
- VDE 0105, Operation of electrical installations
- DIN VDE 0141, Earthing systems for special power installations with rated voltages above 1 kV
- Accident prevention regulations issued by the appropriate professional bodies or comparable organisations. In Germany, these comprise the following safety regulations:
 - Health and Safety at Work Standards BGV A1 and BGV A3
 - Safety guidelines for auxiliary and operating materials
 - Order related details provided by ABB.

1.3 Operating conditions

1.3.1 Normal operating conditions

Design to VDE 0670, part 1000, "Common specifications for high-voltage switchgear and controlgear standards" and IEC publication 60694, with the following limit values:

- Ambient temperature:
 - Maximum + 40 °C
 - Maximum 24 hour average + 35 °C
 - Minimum (according to "minus 25 indoor class") - 25 °C
- Humidity:
 - the average value of the relative humidity measured over a period of 24 h, does not exceed 95%
 - the average value of the water vapour pressure, over a period of 24 h, does not exceed 2.2 kPa
 - the average value of the relative humidity, over a period of one month, does not exceed 90%
 - the average value of water vapour pressure, over a period of one month, does not exceed 1,8 kPa
- Maximum site altitude:
 - ≤ 1000 m above sea level.

1.3.2 Special operating conditions

Special operating conditions are to be agreed on by the manufacturer and user. The manufacturer must be consulted in advance about each special operating condition:

- Site altitude over 1000 m:
 - Allow for the reduction in the dielectric strength of the air.
- Increased ambient temperature:
 - Current carrying capacity is reduced.
 - Provide additional ventilation for heat dissipation.
- Climate:
 - Avoid the risk of corrosion or other damage, e.g. to the operating mechanisms, in areas:
 - with high humidity and/or
 - with major rapid temperature fluctuations.
 - Implement preventive measures (e.g. electric heaters) to preclude condensation phenomena.

2. Structure

2.1 Structure of the operating mechanism (Figures 9/10 to 9/13 and 9/25)

The operating mechanism is of the magnetic type. It fundamentally consists of the magnetic actuator 10, the control module 27 with sensor systems, the storage capacitors 26 and the linkages which transmit the force to the breaker poles.

In addition, there are supplementary components for emergency manual opening and the controls located on the front of the enclosure.

The actuator 10 acts on the three breaker poles via lever shaft 18. The storage capacitors 26 provides the necessary actuating energy on demand.

The mechanical switch positions of the circuit breaker are detected by two sensors 15 and 16 directly at lever shaft 18.

There are rating plates 7 with the main data of the switching device on front plate 1.1, and at the left side in the mechanism enclosure.

The basic version of the magnetic actuator mechanism is fitted with the following controls and instruments:

- ON push-button 3
- OFF push-button 4
- Emergency manual OFF 8
- Mechanical position indicator 6
- Mechanical operating cycle counter 5
- Signal lamp for switching readiness 2 ("READY" lamp).

The following may also be installed:

- Five-pole auxiliary switches for switch position signal: -BB1 and -BB3.

2.1.1 Structure of the control module (Figures 9/13 and 9/15a)

The control module consists of 2 circuit boards:

1. Control board

Control module ED 2.0 produces a voltage of 80 V from any supply voltage within the input voltage range, with which the storage capacitors are charged. This is also used to generate a voltage of 18 V to supply the breaker controller.
2. Power output (upper board)
 - Power electronics for activation of the actuator coils.

2.1.2 Storage capacitor

(Figures 9/13, 9/15b and 9/25)

The electrical energy for operation of the circuit breaker is stored in three capacitors. The capacitors are designed in such a way that the energy for an OFF-ON-OFF operating cycle is provided without recharging.

The energy stored in the capacitors is constantly monitored.

This is accomplished by measuring the capacitor voltage.

When the supply voltage is applied, the "READY" lamp indicates the readiness of the circuit breaker to perform the next switching operation (see sections 3.1.5 and 6.2).

The energy stored in the capacitors is a criterion for illumination of the "READY" lamp:

- Case 1: Breaker in the OFF position.
 - The available energy is sufficient for an ON and OFF operation.
- Case 2: Breaker in the ON position.
 - The available energy is sufficient for an OFF operation.
 - On failure of the supply voltage, the available energy is sufficient during the initial 180 seconds for an OFF operation (see also section 6.5).

When the energy is not sufficient, a NOT READY signal indicates that the circuit breaker is not ready to switch.

2.1.3 Sensor system

(Figures 9/12 and 9/13)

The systematic use of sensors permits control of the circuitbreaker without auxiliary switches.

Two inductive proximity switches 15 and 16 are used to detect the mechanical limit positions, which also provide for self-monitoring of the system.

2.2 Structure of the breaker poles (Figures 9/6, 9/7 and 9/11)

The poles in column design are mounted on the bracketshaped rear part of mechanism enclosure 1. The live parts of the breaker poles are enclosed in cast resin and protected from impacts and other external influences.

With the breaker closed, the current path leads from the upper breaker terminal 25 to the fixed contact 24.2 in the vacuum interrupter 24, then via the moving contact 24.1 and the flexible connector 21 to the lower breaker terminal 22.

The switching motions are effected by means of the insulated link rod 19 with internal contact force springs 20.

2.3 Basic structure of the circuit breaker on withdrawable part (Figures 9/5 to 9/9 and 9/21)

The withdrawable part, which can be moved manually or by a motor if fitted, consists of a steel sheet structure on which the circuit breaker with its ancillary components is mounted.

Insulated contact arms 34 with the spring-loaded contact systems 34.1 are fitted to the circuit breaker poles. These create the electrical connection to the panel when the withdrawable part is inserted into the service position.

A multi-pole control wiring plug connector 36.1 connects the signalling, protection and control wiring between the panel and the withdrawable part.

The withdrawable assembly and the circuit breaker are connected via a multi-pole control wiring plug connector 37.

As soon as the withdrawable part 31 has been slid into the panel and its base frame has engaged in the test/disconnected position, it is positively connected to the panel. At the same time, it is earthed by its travel rollers in their rails. The magnetic actuator mechanism of the circuit breaker, including its controls and indicators, is accessible at the front of the withdrawable part.

Withdrawable parts of the same version are interchangeable. With the same dimensions but different circuit breaker equipment, coding of the control wiring plug prevents impermissible combinations of withdrawable parts and panels (see figure 9/14).

3. Function

3.1 Function of the circuit breaker operating mechanism

3.1.1 Magnetic actuator

(Figure 9/11)

The actuator is the heart of the circuit breaker operating mechanism. It combines the following integrated functions:

- latching in the limit positions,
- release,
- switching.

The actuator is a bistable permanent magnet system in which the armature motion is effected by activating the ON or OFF coil. In the limit positions, the armature is held in place magnetically by the field of two permanent magnets. Release of a switching operation is effected by exciting one of the two coils until the latching force of the permanent magnets is exceeded temporarily.

3.1.2 Opening and closing procedure

(Figures 9/10 to 9/11)

The opening and closing processes can be remote controlled by applying a voltage to input -MC (ON) and -MO1 (OFF) (see also sections 10.1.1a and 6.2). The breaker can be operated locally by pressing push-buttons 3 and 4.

In the closing process, the armature motion acts direct via lever shaft 18 on the moving contact 24.1 until the contacts meet.

In the further motion sequence, the pretensioned spring arrangement 20 is tensioned to 100% and the necessary contact force thus applied. The available overtravel is greater than the maximum contact burn-off throughout the life of the vacuum interrupter

3.1.3 Reclosing sequence

The operating mechanism is fundamentally prepared for reclosing, and with the short recharging time of the storage capacitor (max. 3 s) it is also suitable for multi-shot reclosing.

3.1.4 Circuit breaker controller

All the conditions for control of the opening and closing commands to the magnetic actuator are defined in a fixedprogrammed logic module:

- Supply voltage must be applied to the AC/DC converter.
- The storage capacitors must be sufficiently charged for the next switching operation:

Switch position:	Storage capacitor energy for:
OFF	ON and OFF
ON	OFF

- The moving contacts in the circuit breaker poles must be in a defined ON or OFF limit position.
- The closing coil can only be activated when the breaker is OFF.
- The opening coil can only be activated when the breaker is ON.
- Closing is disabled when an opening command is simultaneously active.
- Activation of the closing coil can be disabled by an external blocking signal.
- The anti-pumping system ensures that only one ON-OFF operation is performed when a closing command is active and followed by an opening command. The active closing command must be cancelled and reset for the next closing operation.
- Deactivation of the opening or closing coil takes place when the relevant limit position has been reached.
- Input -MU "opening command" (undervoltage release) and input -RL1 "closing lock-out" (undervoltage release) must be energized for the circuit breaker to be closed.
- In the as-delivered condition of devices for stationary mounted installation (without wiring), these inputs are therefore provided with a voltage of 80 V by an internal circuit as soon as the storage capacitor is charged.
- If these undervoltage releases are used to monitor a voltage, the voltage to be monitored is to be applied to these inputs.
- If the voltage at undervoltage release -RL1 fails, closing is blocked.
- If the voltage at undervoltage release -MU fails, the breaker opens.
- Undervoltage release -MU (Figures 10/7 and 10/8).

This input switches the VM1-T off if the voltage applied falls below the tolerance range stipulated in IEC 62271.

The nominal value of the voltage to be monitored is set at the works in accordance with the specification in the order. In order to prevent switch-off when the voltage briefly falls below the specified level (e.g. on motor start-up), a tolerance time can additionally be set.

If no voltage is applied to -MU, the VM1-T cannot be closed normally. However a closing support function is provided, that can enable the closing operation even if no voltage is applied to -MU. If after this closing operation no voltage is applied to -MU, the VM1-T will switch off.

The function of -MU can on the control module be deactivated if it is not required. If the function of -MU is deactivated, the VM1-T can be opened and closed without any voltage being applied.

For the coding of the DIP switches, see figure 9/15a.

- Monitoring of the closing and opening coil of the actuator

This function monitors the closing and opening coil of the actuator for cable breakage.

If such a breakage is detected, the “READY” lamp on the front of the switching device goes out and corresponding signals (-DR, -DN) are issued.

- Additional contacts for position signalling
An additional pair of NO contacts to signal the ON and OFF positions are made available by the controller (-DO2, -DC2).
- Direct opening without microprocessor is supported

The second opening input -MO2 is designed in such a way that an opening command is executed directly without being passed through the microprocessor.

3.1.5 The “READY” lamp monitors the following conditions:

- supply of auxiliary power to the VM1-T circuit breaker (see also section 6.2),
- detection of a defined ON or OFF position by the position sensors,
- monitoring of the controlled function of the microprocessor – Watchdog,
- sufficient voltage at the capacitors for the next switching operation (see also section 2.1.2) and
- continuity of the actuator coils.

The “READY” lamp does not monitor the status of inputs -RL1 and -MU. Therefore, it may happen that the VM1 will not perform a closing operation even though “READY” is shining. In that case, the status of inputs -RL1 and -MU has to be checked.

A flashing “READY” lamp signals recharging of the capacitor. Switching readiness is enabled during that time.

3.1.6 Blocking magnet -RL2

(Figure 9/27)

The optional blocking magnet prevents the withdrawable part from being moved when no supply voltage is applied or when the CB is not in OFF position. This interlock is cancelled by applying supply voltage to blocking magnet -RL2.

3.2 Circuit diagrams for circuit breaker withdrawable assemblies

(Figures 9/14, 10/7 and 10/8)

- The circuit diagrams, shown in figures 10/7 and 10/8, comprise the basic equipment and all possible additional equipment for the various VM1-T types. The scope of equipment possible for each type is shown in the relevant switching device list. The equipment fitted in individual cases is detailed in the order documents.

Panel type	Plug type	Figure no.
UniGear type ZS1	58-pole control wiring plug	10/7 and 10/8

The possible coding of a 58-pole plug is shown in figure 9/14.

3. Function

3.3 Quenching principle of the vacuum interrupter

Due to the extremely low static interrupter chamber pressure of 10^{-4} to 10^{-8} hPa, only a relatively small contact gap is required to achieve a high dielectric strength. The vacuum arc is extinguished on one of the first natural current zeros.

Due to the small contact gap and the high conductivity of the metal vapour plasma, the arc drop voltage, and additionally, due to the short arcing time, the associated arc energy, are extremely low, which has advantageous effects on the life of the contacts and thus on that of the vacuum interrupters.

3.4 Interlocks

3.4.1 Interlocks/protection against maloperation (for C.B. on withdrawable parts)

(Figure 9/8)

A series of interlocks are provided to prevent dangerous situations and any maloperation. The interlocks of the panel system ZS and/or the Powerbloc/mounting frame, which are normally effective, are as follows (concerning the circuit breaker):

- The withdrawable part can only be moved from the test/disconnected position into the service position (and back) with the circuit breaker open and the blocking magnet supplied.
- The circuit breaker can only be closed if the withdrawable part is precisely in the defined test position or service position (electrical interlock).
- The circuit breaker can only be opened manually in the service or test position when no control voltage is applied, and it can not be closed.
- The panel is equipped with devices which allow the connection and disconnection of the control wiring plug 36.1 only in the test/disconnected position.
- Details of any additional interlocks, e.g. in connection with a blocking magnet on the earthing switch operating mechanism, can be found in the order documents for each individual case.

3.4.2 Interlocks for VM1-T withdrawable parts

3.4.2.1 Interlocks when ABB withdrawable assemblies are used

(Figures 9/9 and 9/26)

1. The VM1-T can only be closed via input -MC when a voltage of 24 V to 240 V AC/DC is applied to input -RL1 (electrical closing lock-out).
2. The VM1-T can only be closed when the withdrawable assembly is in service or test position. In the intermediate positions, the voltage for the closing lock-out is interrupted by auxiliary switches -BT2 / -BT1.
3. A mechanical interlock 35.5 and 41.2 prevents a closed breaker that is not in the OFF position being moved.

3.4.3 Interlocks when non-original withdrawable assemblies are used

(Figure 9/26)

VM1-T circuit breakers which are not mounted on ABB withdrawable part must be electrically interlocked with one or two additional auxiliary switches. These must interrupt the input voltage to the electrical closing lock-out (input -RL1).

In a similar manner to auxiliary switches -BT2 and -BT1 on the ABB withdrawable part, no further electrical pulse may be received by -RL1 after the first half revolution of spindle system 35.1, and it may only be re-applied after the last half revolution. This ensures that the circuit breaker cannot be closed when the withdrawable part is in an intermediate position.

A mechanical interlock as described in 3.4.2.1 part 3.) is to be implemented to prevent a circuit breaker which is not in the OFF position being moved. The slide blocker 41.2 on the VM1-T (optional accessory for stationary mounted breakers) can be used for this purpose: the slide blocker is outside base plate 41.4. Figure 9/9 shows pawl 35.5 on the ABB withdrawable part. With the circuit breaker not in the OFF position, pawl 35.5 cannot be moved upwards. This prevents movement of the withdrawable assembly and therefore movement of the circuit breaker.

Note:

Additionally fitted interlocks must not exert any force on the operating mechanism of the circuit breaker.

If the interlock mechanism projects beyond the base of the circuit breaker casing, measures must be taken to prevent the the circuit breaker from weighing down on the interlock, for instance during transport.

4. Despatch and storage

4.1 Condition on delivery

- **The factory-assembled switching devices are checked at the works for completeness of the equipment installed and simultaneously subjected to a routine test in accordance with VDE 0670, part 1000 or IEC publication 60694, thus verifying their correct structure and function.**

The storage capacitors 26 are discharged by the connected control electronics, and have a terminal voltage < 10 V on delivery.

4.2 Packaging

The switching devices are mounted individually on a wooden pallet and sealed in film and/or packed in cardboard for delivery.

Packaging for overseas shipment:

- Drying agent bags inserted in the film sealed packaging.
- Drying agent bags according to DIN 55 473.

4.3 Transport

Loading of the package units must only be carried out with a



- crane,
- fork-lift truck and/or
- trolley jack.

Notes:

- Avoid impact during handling.
- Do not subject to other damaging mechanical stresses.
- Lifting gear must not be attached to the breaker poles or parts of the operating mechanism. Use lifting bores 1.2 and lifting lugs, e.g. in figure 9/10 and in the dimensional drawings.

4.4 Delivery

The duties of the consignee on receipt of the switching devices at site include the following:

- Checking the delivery for completeness and freedom from damage (e.g. moisture and its adverse effects).
- Any short quantities, defects or damage in transit:
 - Must be precisely documented on the consignment note.
 - The shipper/carrier is to be notified immediately in accordance with the liability provisions of the German general conditions for forwarders (ADSp/KVO).

Note:

Always document any major damage with photographs.

4.5 Intermediate storage

Conditions for optimum intermediate storage:

1. Devices with basic packaging or unpacked:
 - A dry and well ventilated storeroom with climate in accordance with VDE 0670, Part 1000 / IEC 60694.
 - Room temperature which does not fall below -25 °C.
 - Do not remove or damage the packaging.
 - Unpackaged devices:
 - Are to be loosely covered with protective sheeting.
 - Sufficient air circulation must be maintained.
 - Check regularly for any condensation.
2. Devices with seaworthy or similar packaging with internal protective sheeting:
 - Store the transport units:
 - protected from the weather,
 - dry,
 - safe from damage.
 - Check the packaging for damage.
 - If the maximum storage period starting from the date of packaging has been exceeded:
 - The protective function of the packaging is no longer guaranteed.
 - Suitable action must be taken if intermediate storage is to continue.
3. Storage capacitor 26:
 - There is no limit on storage when the above conditions are fulfilled.

5. Installation and mounting of the breaker

Careful and professional installation of the switchgear is one of the fundamental conditions of trouble-free circuit breaker operation.

- Install the mechanism enclosure in the panel without distortion, placing a dished washer under the nut and bolt head at each of the four mounting points (depending on the order).
- Connect the main terminals without any residual tension or pressure forces, exerted for example by the conductor bars.
- When connecting the conductor bars, the bolts must be inserted to the depth shown on the dimensional drawing.
- Observe the tested terminal zone where appropriate.
- Use DIN bolts of tensile class 8.8 together with dished washers to fasten the conductor bars.
- Only use the tightening torques shown in the following table.
- Remove any contamination (see also section 7.3.1.).

Thread	Recommended tightening torque (1)	
	Nm	
	Lubricant (2)	
	without (dry)	Oil or grease
M 06	10.5	4.5
M 08	26	10
M 10	50	20
M 12	86	40
M 16	200	80

- (1) The rated tightening torques for fasteners without lubrication are based on a coefficient of friction for the thread of 0.14 (the actual values are subject to an unavoidable, partly not inconsiderable, spread).
Rated tightening torques for fasteners with lubrication in accordance with DIN 43 673.
- (2) Thread and head contact surface lubricated.
Any tightening torques which deviate from those in the general table (e.g. for contact systems or device terminals) are to be taken into account as stated in the detailed technical documentation. It is recommended that the threads and head contact surfaces of screws should be lightly oiled or greased, so as to achieve a precise rated tightening torque.

6. Commissioning / Operation

6.1 Notes on safety at work



- Operation is only permissible by specially trained personnel who are familiar with the characteristics of the particular switching device.
- Observe the relevant specifications as set out in section 1.2.
- Before a VM1-T on the withdrawable part is moved it must be verified that the circuit breaker is switched off. This is the case when the mechanical position indicator 6 shows the position "O" and when "READY" is shining on the READY lamp 2 while the breaker is supplied with auxiliary voltage.
- Due to safety reasons, the circuit breaker has to be treated as "switched on" if the switching position can not be clearly determined. In this case all high voltage connections to the breaker have to be de-energized and zero potential on the primary side of the breaker has to be confirmed prior to commissioning, operation, maintenance or repair work.
- The discharge energy of the storage capacitor is greater than 350 mJ. The procedure for discharge of the storage capacitor as set out in section 7.1 is to be observed.

6.2 Preparatory activities (before connecting the primary voltage)

- Check the circuit breaker, withdrawable part, contact arms, insulating parts etc. for damage, and restore to their proper condition if necessary.
- Remove any dirt collected during transport, storage or installation (particularly on the insulating materials) as described in section 7.3.1.



- Remove lifting lugs T (Figures 10/2, and 10/5).
- Check the primary and secondary connections and the protective earth conductor connection.
- Check the connection of the main earthing bar with the station earthing conductor (DIN VDE 0141).

- Remove all material residues, foreign bodies and tools from the switchgear.
- Properly refit all covers, etc., removed during assembly and testing processes.
- Connect the supply voltage (Figures 9/15b, 10/7 and 10/8) - "READY" will shine. Inputs -RL1: "Closing lock-out" and -MU: "Undervoltage release" (if applicable) must be supplied with power before the circuit breaker can be closed.
- For this reason, an internal circuit applies a voltage of 80 V to the input -RL1 (Figure 9/15b), as soon as the storage capacitor is charged in as-delivered condition of devices with no connector wiring.
- "READY" will shine even if the closing operation is blocked by inputs -RL1 or -MU.
- If no voltage is applied to input -RL1, closing is impossible.
- If no voltage is applied to input -MU, closing is impossible in case of activated -MU and not activated closing support.
- Storage capacitors 26:
Following a (de-energised) storage period of more than 2 years, reforming on initial start-up leads to a temporary increase in current consumption at the AC/DC converter, which is however below 2 A.
- Check mechanical and electrical interlocks for effectiveness, without using force.
- Perform test closing and opening of the circuit breaker by pressing push-buttons 3 and 4 (see Figure 9/16).
- On motor-driven withdrawable parts, check the direction of rotation of the travel motors as described in section 7.5.3.
- For any further questions on the functions of the withdrawable circuit breaker part and its testing, see section 7.5.
- Instruct the local operators in the fundamental details of regular handling of the switchgear.

6.3 Earthing

For the fixed version circuit breaker, carry out earthing by means of the special screw marked with the relative symbol.

Clean and degrease the area around the screw to a diameter of about 30 mm and, on completion of assembly, cover the joint again with Vaseline grease. Use a conductor (busbar or braid) with a cross-section conforming to the Standards in force.

6. Commissioning / Operation

6.4 Movement of the withdrawable breaker part (Figures 9/9, 9/16 and 9/20 to 9/22)

Perform switching operations with the front doors shut.

6.4.1 Manual insertion from the test/disconnection position to the service position

- Connect control wiring plug 36.1.
- Close the front door.
- Ensure that the circuit breaker is in the OFF position.
- Fit hand crank 38 on square spigot 35.2 of the spindle mechanism 35.1.

Note:

In order to avoid damage to the operating mechanism, use the original hand crank only:

- Standard version without slip clutch,
- Optional version with slip clutch.
- Turn the crank clockwise according the table until the stop is reached and the withdrawable part 31 is in the service position.

Note:

Do not use force to move the withdrawable breaker part (Maximum torque 25 Nm!)

Comply with the conditions for movement of the withdrawable part as set out in section 7.5.4!

Panel type	Number of crank turns	
	12/17.5 kV	24 kV
UniGear type ZS1	20	30

- Observe the position indicator in the front door.
- Remove hand crank 38 by first pressing slightly against the hand crank and then remove.

Note:

When removing the crank, it is essential to ensure that the spring-loaded guide 35.6 slides into the untensioned front position. Spindle 35.1 is thus locked in place, preventing inadvertent turning of the spindle. Turning of the spindle opens auxiliary switches -BT2 / -BT1 and thus prevents the circuit breaker from being operated.

Note:

The withdrawable part must not be stopped at any position in the travel range between the service position and test/disconnected position!

6.4.2 Manual withdrawal from the service position into the test/disconnected position

- Ensure that the circuit breaker is in the OFF position.
- Reverse the procedure described above for insertion into the service position.

Note:

Withdrawable parts with blocking magnet -RL2 may not be forcibly moved during power failures. In such a case they are blocked in the service and test positions. For deblocking, see section 7.5.4.

6.4.3 Motor-driven movement of the withdrawable part

- Briefly operate the electrical control for insertion or withdrawal (the withdrawable part then automatically moves into the opposite position).
- Observe the position indicator in the front door.

Note:

When the motor fails, the withdrawable part can be moved in emergency manual operation. If the drive motor fails during movement of the withdrawable part, the withdrawable part must be moved into a limit position in emergency manual operation.

Emergency manual operation:

Emergency manual operation is carried out with the hand crank 38 on the spindle mechanism 35.1, in a similar manner to operation of a withdrawable breaker part with manual systems:

- Turn off the supply voltage (m.c.b.), since the motor would otherwise be braked electrically.
- Turn hand crank 38 in the required direction.
- When the withdrawable part moves, the motor turns. The motor functions in such a case like a generator, i.e. it can lead to reverse voltages in the terminals.
- The motor protection device must not be changed from the specified type and rated value, or the behaviour of the permanent magnet motor could be irreversibly impaired.

6.4.4 Withdrawal from the test/disconnected position onto the service truck (Figures 9/21 and 9/22)

- Open the door of the circuit breaker compartment.
- Pull out control wiring plug 36.1 and place it in the receptacle provided.
- Position service truck 40 with the guide pins 40.2 of the adjustable bench top at the correct height facing the panel front, and allow catch 40.3 to engage.
- Move sliding handles 35.3 inwards against the springs to release withdrawable part 31, withdraw onto the service truck and secure it in the catches on the truck.
- Press the release lever (at the front underneath the bench top) and release the service truck from the panel.

6.4.5 Insertion from the service truck into the test/disconnected position

- Carry out the procedure as described above for withdrawal, changing the order accordingly.

6.5 Operation of the circuit breaker (Figures 9/16 to 9/19)

Voltage is applied when switching readiness is indicated ("READY" lamp 2 lights up).

Please also observe the notes in section 3.1.5.

1. Closing:
 - By remote control, by applying a voltage to input -MC (see also sections 10.1.1a and 6.2) or locally by pressing ON pushbutton 3.
2. Opening:
 - By remote control, by applying a voltage to input -MO1 (see also sections 10.1.1a and 6.2) or locally by pressing OFF pushbutton 4.

3. Opening on failure of the supply voltage:
 - a) Initially, for a period of 180 seconds, opening by remote control or by pressing pushbutton 4 is still possible.
 - b) During the subsequent period, emergency manual opening of the breaker is possible. Insert emergency OFF lever 28 into the receptacle 8 on the front plate and turn it anti-clockwise to open the circuit breaker. First, spring 29 on lever 28 has to be tensioned. At the end of the tensioning motion (approx. 65° to 70°) a tangible resistance caused by the disengagement of the actuator armature has to be overcome. The circuit breaker is then switched off, and any further turns would have no effect.
4. Closing on failure of the supply voltage: Closing is not appropriate and not possible.
5. Operating cycle and switching condition indicators on the switching device:

After every operating cycle (ON-OFF), operating cycle counter 5 is incremented by one full digit. On completion of a switching operation, switch position indicator 6 shows the current switch position.
6. Anti-pumping system:
 - The circuit breaker controller ensures that closing of the circuit breaker is blocked when an opening command is active.
 - On closing with a following opening command, renewed closing while the closing command is still applied is blocked. A further closing command has to be issued for the next closing operation.

7. Maintenance

Maintenance serves to preserve trouble-free operation and achieve the longest possible working life of the switchgear. In accordance with DIN 31 051 and IEC 61208, it comprises the following closely related activities:

Inspection:

Determination of the actual condition

Servicing:

Preservation of a functional condition

Repair:

Measures to restore the functional condition

7.1 General

All vacuum circuit breakers are simple and robust in design. They can be expected to have a long service life. The vacuum is not even impaired by frequent switching of operating and short-circuit currents. The typical life expectancy of a VM1-T vacuum circuit breaker is a function of:

- Maintenance-free, embedded vacuum interrupters for up to 2,000 mechanical operating cycles.
- Maintenance-free control module with sensor system and no auxiliary switches.
- Auxiliary switch for ON/OFF position signalling (optional) for up to 2,000 operating cycles.
- Withdrawable assembly: With careful operation and appropriately performed inspection work, up to 1,000 movements can be performed.

See also IEC 60298.

Concerning detailed information about the maintenance of the VM1-T circuit breaker please contact the ABB service.

The service life data fundamentally refer to all components which are not directly influenced by the operator.

Deviations can occur for parts operated manually (movement of the withdrawable part, etc.), depending on how they are handled.

The servicing intervals and scope are determined by the environmental influences, the switching frequency and the number of short-circuit breaking operations.

Note:

The following must be observed for all maintenance work:

- The relevant specifications in section 1.2.2
- Notes on safety at work in section 6.1
- Standards and specifications in the country of installation.

Maintenance work may only be performed by fully trained personnel, observing all the relevant safety regulations. It is recommended that ABB after-sales service personnel should be called in, at least during the performance of servicing and repair work. While the work is in progress, and if the work permits, all supply voltage sources must also be disconnected and secured to prevent re-connection.

Note:



In order to prevent accidents (particularly injury to hands!) extreme care should be taken during all repair work on the operating mechanism, especially with front plate 1.1 removed.

The energy of the storage capacitor can be released uncontrollably during incorrect handling!

Procedure for capacitor discharge:

1. Close the circuit breaker.
2. Turn off the supply voltage (m.c.b.).
3. Switch the circuit breaker in the following cycle by pressing pushbuttons 3 and 4: OFF/ON/OFF. On completion of this switching cycle the "READY" lamp goes out, i.e. the circuitbreaker is no longer ready for operation.
4. After approx. 12 minutes, the storage capacitors have discharged to less than 15 V:

In addition to this instruction manual, it may be necessary in individual cases to observe further details in the technical documentation for the switchgear (e.g. on special operating conditions if stipulated).

7.2 Inspection and functional testing

7.2.1 Circuit breaker in general

- Under normal operating conditions, inspection within the stated number of operating cycles is not necessary.
- Inspection may be necessary under exceptional operating conditions (including adverse climatic conditions) and/or particular environmental stresses (e.g. serious contamination and aggressive air).
- The inspection primarily comprises visual examination for contamination, corrosion, moisture and discharge phenomena on the high voltage side.
- If an irregular condition is found, appropriate maintenance work is to be initiated.

- No external discharge may occur on the surfaces of equipment at operating voltage. This can, for example, be detected by characteristic noises, a clearly perceptible smell of ozone, or visible glowing in the dark.
- If irregular conditions are detected, then corresponding repair measures should be initiated.

7.2.2 Magnetic actuator operating mechanism (Figures 9/11 and 9/19)

A first functional test of the operating mechanism is to be performed:

- after the stated number of operating cycles, or
- during maintenance work as described in section 7.2.1.

Before the functional test, open the circuit breaker and

- move it into the test position (withdrawable breaker) or
- isolate and secure the working area in accordance with the Safety Regulations to DIN VDE / IEC (with stationary mounted breakers).
- Observe the procedure for capacitor discharge as set down in section 7.1.
- Perform visual examination of the condition (removing front plate 1.1), e.g.:
 - the lubrication at the rotary bearings,
 - the operating cycle counter,
 - the sensor mounting,
 - the position indicator.

Scope of functional testing:

- Connect the supply voltage.
- Perform several switching operations under no load. This is predominantly applicable to circuit breakers which are rarely operated under normal circumstances.
- Perform one rapid OFF/ON/OFF operation with the circuit breaker to check the storage capacitors by pressing buttons 3 and 4 rapidly in sequence.
- The LEDs on the inductive proximity switches 15 and 16 are activated when the circuit breaker has reached its OFF and ON limit positions respectively.

7.2.3 Withdrawable part

- The inspection should always include a visual examination of the withdrawable part assembly. Special attention is to be paid to those parts which may possibly be damaged by improper handling.

- Perform a visual check on the condition of the isolating contact system. It is recommended that the contact system be turned alternately so that its inner contact points can be cleaned. If there are signs of impermissible overheating (discoloured surface), the contact points are to be cleaned (see the section on repairs).
- The interlock conditions and the ease of movement of the withdrawable assembly are to be checked as described under "Repair".
- When checking the interlock conditions, it is essential to ensure that no force is used.

Maximum torque 25 Nm!

7.3 Servicing

7.3.1 Circuit breaker in general

If the necessity of cleaning is established during inspections as described in 7.2.1, the following procedure is to be adopted:

- Prior to cleaning, isolate and secure the working area if necessary in accordance with the safety regulations of DIN VDE and IEC.
- Observe the procedure for capacitor discharge as set down in section 7.1.
- Cleaning of surfaces in general:
 - Remove weakly adhering dry dust deposits with a soft dry cloth.
 - Remove more strongly adhering dirt with a slightly alkaline household cleanser, or with Rivolta BWR 210.
- Cleaning of insulating material surfaces and conductive parts:
 - Minor contamination: with Rivolta BWR 210.
 - Strongly adhering contamination: with cold cleanser 716.

After cleaning, wipe down with clean water and dry carefully.

- Observe the manufacturer's instructions and the special ABB instruction manuals BA 1002/E or BA 1006/E on safety at work.

Note:

Use only halogen-free cleaning agents. Never use 1.1.1-trichloroethane, trichloroethylene or carbon tetrachloride!

7.3.2 Magnetic actuator operating mechanism

The magnetic actuator mechanism is maintenance-free up to the number of operating cycles stated in section 7.1.

7. Maintenance

7.3.3 Breaker pole

The breaker pole with the vacuum interrupter is maintenancefree up to the permissible number of operating cycles as sent down in section 10.1.3. The working life of the vacuum interrupter is defined by the sum current limit corresponding to the equipment data in individual cases in accordance with section 10.1.3:

- When the sum current limit is reached, the complete breaker poles are to be replaced.

Note:

Dismantling and replacement of the breaker poles should only be performed by the ABB after-sales service or adequately trained specialist staff, in particular with regard to the necessity for precise setting.

The following equipment, for example, can be used to check the vacuum (without dismantling the circuit breaker):

- VIDAR vacuum tester, from
Programma Electric GmbH
Bad Homburg v.d.H., Germany

The following test values have to be set for checking of the internal interrupter chamber pressure with the VIDAR vacuum tester:

Rated voltage of the circuit breaker	DC test voltage
12 kV	40 kV
17.5 kV	40 kV
24 kV	60 kV

Testing is to be performed at the rated contact distance in the OFF condition.

Procedure for vacuum interrupter testing for stationary mounted switching devices:

- Isolate and secure the working area in accordance with the Safety Regulations to DIN VDE / IEC.
- Open the VM1-T circuit breaker.
- Earth all poles of the VM1-T circuit breaker on one side.
- Connect the earthed test lead of the VIDAR vacuum tester conductively to the station earth.
- Connect the high voltage test lead of the VIDAR vacuum tester with phase L1 of the unearthed pole side and test the vacuum interrupter chamber with the circuit breaker contact gap open. Repeat for phases L2 and L3.

Note:

Connected cables may lead to a “defective” indication on the vacuum tester as a result of their cable capacitance. In such cases, the cables are to be removed.

7.4 Repair

7.4.1 Repair of surface damage

Circuit breaker part in general

- Sheet steel parts, painted:
 - Remove rust, e.g. with a wire brush.
 - Grind off paint coat and degrease.
 - Apply anti-rust primer and top coat.
 - Use a top coat in the standard colour RAL 7035 or the relevant special colour.
- Sheet steel parts with aluminium-zinc surfaces and chromated functional parts:
 - Remove white rust, with a wire brush or cleaning pad (e.g. Scotch-Brite, white).
 - Remove loosely adhering particles with a dry cloth.
 - Apply zinc spray or zinc dust primer.
- Functional parts, phosphated:
 - Remove rust, with a wire brush or cleaning pad (e.g. Scotch-Brite, white).
 - Clean with a dry cloth.
 - Grease with Isoflex Topas NB 52 lubricant.

Withdrawable circuit breaker part in general:

- Where required, regrease or thoroughly clean slide plates and bearings in the panel and regrease them with Isoflex NB 52 lubricant.
- Remove the contact system for thoroughly cleaning as described below (Figures 9/23 and 9/24):
- Slide the two inner annular tension springs 34.2 facing the breaker pole to a position beside the other two outer annular tension springs, thus releasing contact system 34.1, and remove the contact system from contact arm 34.
 - The contact pin of the contact system and the slot on the contact arm are to be cleaned and greased.
 - Fit the contact system back to front on the thin end of arbor 39, and slide it forwards onto the thicker part of the shank.
 - Fit arbor 39 onto the relevant contact arm 34, slide the contact system 34.1 over onto the contact arm, and withdraw the arbor.
 - Check all contact fingers and annular tension springs for perfect fit.

Note:

The set installation position of contact arms 34 must not be changed by the improper use of force.

7.4.2 Replacement of components

- Only remove and reassemble circuit breaker parts and accessories when the breaker has been switched off and the working area is to be isolated and secured against reclosing.

- All supply voltage sources must be disconnected and secured to prevent reconnection during the removal and installation work.
- The storage capacitor is to be discharged in accordance with the instructions in section 7.1.

1. Circuit breaker control module:
 - Replacement of the circuit breaker control module may only be performed by ABB after-sales service personnel or by specially trained specialists. This is because the internal sequence times are set by jumpers on each individual control unit.
2. Withdrawable assembly:

(Figures 9/8, 9/9, 9/26 and 9/27)

 - Disconnect plug connector 37.
 - For motorized withdrawable assemblies, remove the two socket head bolts which are accessible from below the assembly.
 - Unbolt the circuit breaker from the withdrawable assembly (4 x M12 bolts).
 - Mount the circuit breaker on a new withdrawable assembly in the reverse order.
 - Check the settings of the slide blocker 41.2:
 - The circuit breaker is in the ON position.
 - The distance between pawl 35.5 on the withdrawable assembly and slide blocker 41.2 must be $0.1 + 0.4$ mm. If a correction is necessary, the screws 41.3 are to be released and the slide blocker 41.2 is to be adjusted by a feeler gauge. Thereafter the screws must be fixed again.

7.5 Test on withdrawable parts with VM1-T type circuit breakers

The following conditions are to be checked to test the function of the withdrawable part.

7.5.1 Motor-driven withdrawable parts (non-standard)

Inspection of motor-driven withdrawable parts should be performed as for manually operated withdrawable parts in accordance with Section 7.5.2:

- Turn off the supply voltage (m.c.b.), since the motor could otherwise be braked electrically.
- Turn hand crank 38 in the required direction (see Figure 9/25).

Note:

When the withdrawable part moves, the motor turns. The motor functions in such a case like a generator, i.e. it can lead to reverse voltages in the terminals.

7.5.2 Checking the auxiliary switch settings on withdrawable parts

(Figures 9/14 and 9/25)

Compliance with the interlock conditions in the test/disconnected and service position areas is ensured by position signalling switches -BT2 and located in the withdrawable assembly and factory-set.

In test operations, the withdrawable part must be moved by hand with the crank fitted with the motor power switched off.

1. Settings in the area of the test/disconnected position:
 - Move the withdrawable part out of the test/disconnected position towards the service position with a few turns of the crank.
 - Slowly move the withdrawable part back to the stop. Auxiliary switch -BT2 must then switch over just before the stop is reached.
 - Slowly insert the withdrawable part from the test/disconnected position towards the service position until auxiliary switch -BT2 just operates (approx. 30° rotation of the crank). It is no longer possible to switch the circuit breaker on in this position. When the hand crank is turned further, the position of the circuit breaker is polled by pawl 35.5 after a total angle of turn of approx. 90°. If the circuit breaker is closed, the withdrawable part cannot be moved any further.
 - For this test, the function of the blocking magnet -RL2 (if fitted) must be disabled manually.
2. Settings in the area of the service position:
 - Move the withdrawable part out of the limit position towards the test/disconnected position with a few turns of the crank.
 - Slowly move the withdrawable part forwards again to the stop. Auxiliary switch -BT1 must then switch over just before the stop is reached.
 - Slowly move the withdrawable part out of the service position towards the test/disconnected position until auxiliary switch -BT1 just responds (approx. 30° rotation of the crank). When the hand crank is turned further, the position of the circuit breaker is polled by pawl 35.5 after a total angle of turn of approx. 90°. If the circuit breaker is closed, the withdrawable part cannot be moved any further.

7. Maintenance

7.5.3 Checking the direction of rotation of the travel motors on motor-driven withdrawable parts

- Move the withdrawable part by hand into a central position between the test/disconnected position and the service position.
- Remove the hand crank.
- Switch the supply voltage for the travel motor on.
- Use the local electrical controls to check that the withdrawable part moves in the correct direction.

Caution:



Do not allow the withdrawable part to run up against a block when the travel direction is incorrect! Switch the motor power off immediately (the travel process functions electrically by a seal-in system with limit position switch-off).

There may be a danger of injury when the door is open!

7.5.4 Checking of interlock conditions (Figures 9/16 and 9/20)

1. The withdrawable part must only be movable from the test/ disconnected position into the service position when the circuit breaker is open. Check this conditions as follows:
 - With the circuit breaker closed, insertion of the withdrawable part towards the service position must be blocked after only half a turn of the crank in the clockwise direction, and the travel motor on motor-operated withdrawable parts must not be capable of being switched on.

Do not use force
(maximum torque 25 Nm)!

2. The withdrawable part must only be movable from the service position into the test/ disconnected position with the circuit breaker open. Check this condition as follows:
 - With the circuit breaker closed, withdrawal movement of the withdrawable part must be blocked after only half a turn of the crank in the anti-clockwise direction, and the travel motor on motor-operated withdrawable parts must not be capable of being switched on.
3. Closing of the circuit breaker must only be possible when the withdrawable part is in the defined test/disconnected position or service position. The control wiring plug 36.1 must previously have been inserted.

Check this condition as follows:

- It must not be possible to close the circuit breaker with the withdrawable part in any position between the test/ disconnected position and the service position.
 - Readiness for switching is established electrically when the service position is reached by auxiliary switch -BT1 in the withdrawable assembly switching over.
 - For motion into the test/disconnected position, the same enabling conditions apply analogously, in this case by means of auxiliary switch -BT2 in the withdrawable assembly.
4. It must only be possible to open the circuit breaker manually in the service position and in the test/disconnected position on failure of the supply voltage:
 - a) Initially by pressing OFF pushbutton 4, until 180 seconds have expired.
 - b) In subsequent periods, emergency manual opening with operating lever 28 is possible.
 5. Withdrawable parts with order-related blocking magnet -RL2 may not be moved in case of control power failure, or when there is no control power. Do not forcibly move blocked withdrawable parts! The blocking magnet -RL2 is only present on manually operated withdrawable parts (Figure 9/25).

Releasing the blocking magnet -RL2:

- Remove front plate 1.1,
 - disengage blocking magnet -RL2 by pulling the magnet armature,
 - while doing so, turn crank 38 about one half turn (either direction of rotation is permissible).
- The blocking magnet is only active in the test position and service position. In intermediate positions it has no effect.

7.6 Spare parts, auxiliary materials, lubricants

7.6.1 Spare parts

When parts are required, the serial number of the relevant withdrawable breaker part or circuit breaker should always be quoted. Setting instructions are to be requested separately.

Withdrawable assembly of VM1-T:

- Manually movable withdrawable assembly:
 - See drawing GCE 7003570, sheets 1 and 2, for notes for setting of auxiliary switches -BT2 / -BT1 and slide blocker.
- Motor-driven withdrawable parts:
 - For notes on settings see drawing GCE 7003571.
- Blocking magnet -RL2:
 - For notes on settings see drawing GCE 7003820, sheet 1 (table 2).

7.6.2 Auxiliary materials and lubricants

Designation	Part no. (order code)
Lubricant:	
Isoflex Topas NB 52	GCE0007249P0100
Halogen-free cleansers:	
Rivolta BWR 210 (for general cleaning)	GCE0007707P0100
ABB Instruction manual BA 1002/E	GCEA901002P0101
Cold cleanser 716 (for use with conductive components, components of insulating materials and in case of serious grime!)	GCE0007706P0100
ABB Instruction manual BA 1006/E	GCEA901006P0101
Paint:	
Touch-up paint: Standard colour RAL 7035	
- 1-kg-box	GCE9014060R0103
- Spray tin	GCE0007895P0100

Table: VM1-T withdrawable part

Designation	Item no.	Rated supply voltage	Part no. (order code)
Auxiliary switch for manually operated mechanism	-BT2 / -BT1		
- Silver-plated contacts			GCE7004024R0101
- Gold-plated contacts			GCE7004024R0103
Auxiliary switches for motor-operated driving mechanism	-BT2 / -BT1		
- Silver-plated contacts			GCE7004024R0102
- Gold-plated contacts			GCE7004024R0104
Blocking magnet	-RL2	24 V	GCE7003820R0101
		30 V	R0102
		48 V	R0103
		60 V	R0104
		110 V	R0105
		125 V	R0107
		220 V	R0106
Motor with gearbox	-MT	24 V	GCE0940150P0111
		30 V	P0112
		48 V	P0113
		60 V	P0114
		110 V .. 125 V	P0115
		220 V	0116

Designation	Item no.	Part no. (order code)
Auxiliary switch for ON/OFF position signalization	-BB1 / -BB3	
- Silver-plated contacts		GCE7002397R0119
- Gold-plated contacts		GCE7002397R0125

Designation	Rated supply voltage	Part no. (order code)
Breaker controller VM1-T with power pack A	24 V ... 48 V AC	GCE7004902R0136
	24 V ... 60 V DC	
Breaker controller VM1-T with power pack B	100 V ... 240 V AC	GCE7004902R0137
	110 V ... 240 V DC	

8. Application of the X-ray regulations

One of the physical properties of vacuum insulation is the possibility of X-ray emissions when the contact gap is open.

The specified test performed by the Physikalisch-Technische Bundesanstalt (PTB) in Braunschweig demonstrates that the local dosage output of 1 $\mu\text{Sv/h}$ at a distance of 10 cm from the touchable surface is not exceeded when the rated voltage is applied.

The results are as follows:

- Testing of the switching device or the vacuum interrupter to VDE 0671 part 100 or IEC 62271-100 at the relevant rated power frequency withstand voltage may only be performed by trained personnel observing the stipulations of the EU basic standard (Stipulation 96/29/Euratom of the senate from 13 May 1996 (ABl.L 159 from 29 June 1996)).
- Application of the rated voltage specified for the switching device by VDE 0671 part 100 or IEC 62271-100 is completely safe.
- Higher voltages than the rated voltage or DC test voltage specified in VDE or IEC standards must not be applied!
- The containment of the above mentioned local dosage output with the vacuum interrupter in the open position is dependent on maintenance of the specified distance between the contacts (which is automatically ensured with correct mechanism function and force transmission).
- Safety clearances must be maintained.

9. Figures



Figure 9/1: Vacuum circuit breaker, type VM1-T, for fixed installation, 12 kV, ≤ 1250 A, ≤ 25 kA, mechanism side.



Figure 9/2: Vacuum circuit breaker, type VM1-T, for fixed installation, 12 kV, ≤ 1250 A, ≤ 25 kA, pole side.



Figure 9/3: Vacuum circuit breaker, Typ VM1-T, for fixed installation, 12 kV, 1600 ... 2000 A, 25 kA, mechanism side.



Figure 9/4: Vacuum circuit breaker, Typ VM1-T, for fixed installation, 12 kV, 1600 ... 2000 A, 25 kA, pole side..



Figure 9/5: Vacuum circuit breaker, type VM1-T, on withdrawable part, 24 kV, 1250 A, ≤ 25 kA, mechanism side.

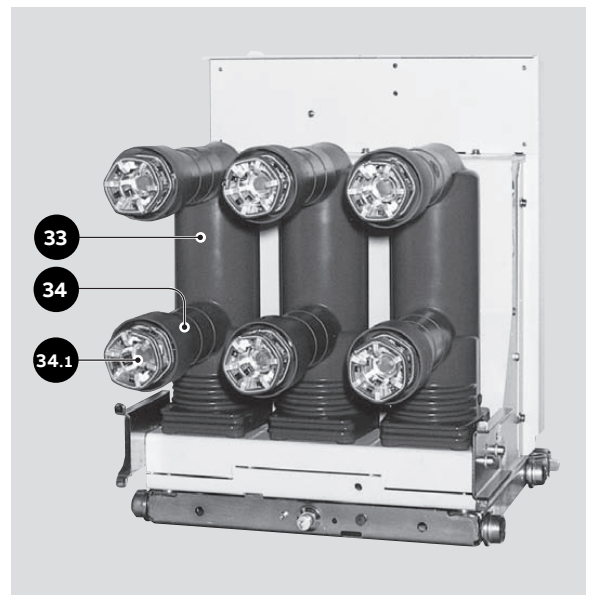

Figure 9/6: Vacuum circuit breaker, type VM1-T, on withdrawable part, 12 kV, 630 A, ≤ 25 kA, pole side.
 33 Breaker pole
 34 Contact arm with insulating tube (versions for rated currents to 1250 A and above have shrink sleeves)
 34.1 Contact system

9. Figures

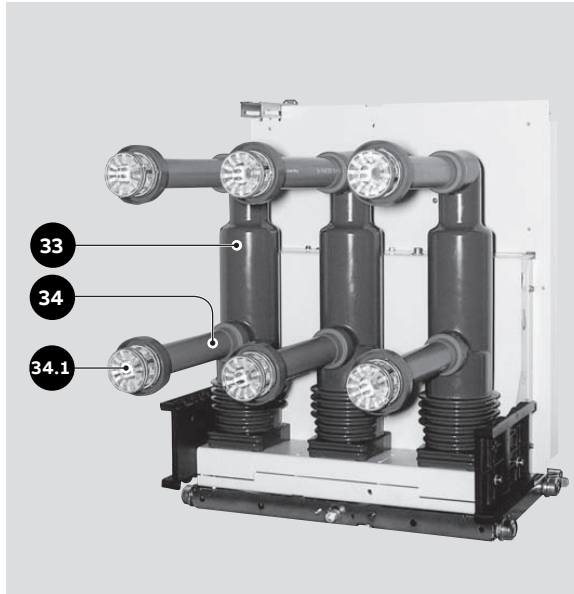

Figure 9/7: Vacuum circuit breaker, type VM1-T, on withdrawable part, 24 kV, 1250 A, ≤ 25 kA, pole side.
 33 Breaker pole
 34 Contact arm with insulating tube (versions for rated currents to 630 A and above have insulating tubes)
 34.1 Contact system

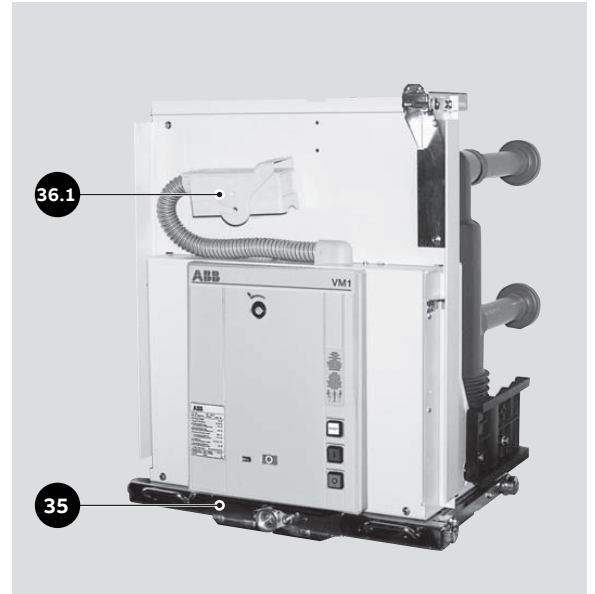

Figure 9/8: Vacuum circuit breaker, type VM1-T, on withdrawable part, 24 kV, 1250 A, ≤ 25 kA, mechanism side.
 35 Withdrawable assembly
 36.1 Control wiring plug

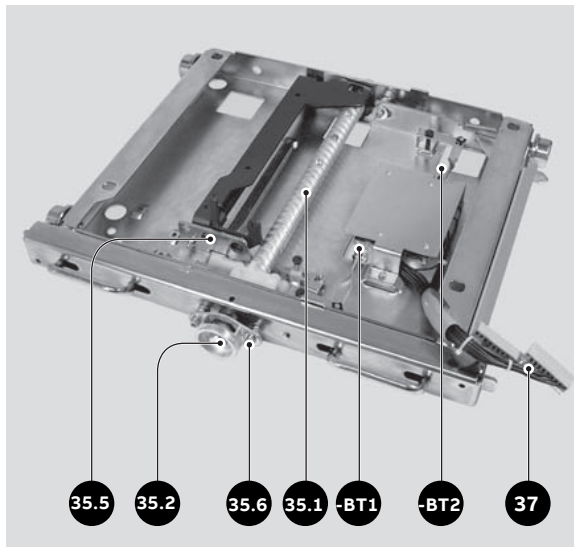

Figure 9/9: Withdrawable part with built-in auxiliary switch
 -BT2 Test position indicator
 -BT1 Service position indicator
 35.1 Spindle mechanism
 35.2 Square spigot
 35.5 Pawl
 35.6 Scene head on spindle
 37 Control wiring plug connector for withdrawable assembly

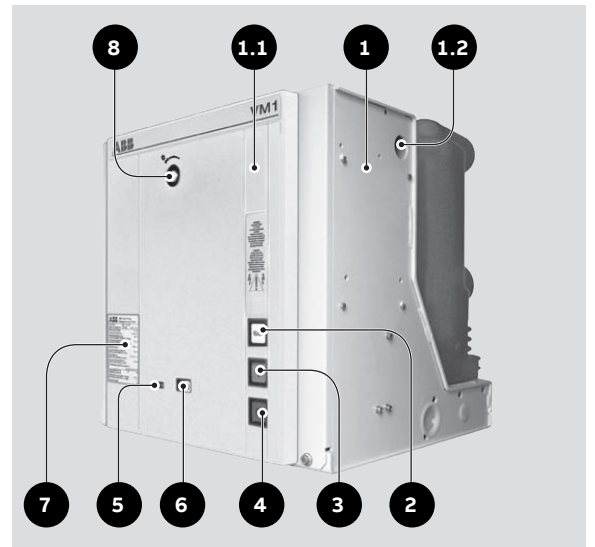

Figure 9/10: Circuit breaker front with controls and annunciations.
 1 Mechanism enclosure
 1.1 Front plate
 1.2 Bore for handling, both sides
 2 "READY" lamp
 3 ON push-button
 4 OFF push-button
 5 Mechanical operating cycle counter
 6 Mechanical position indicator
 7 Rating plate
 8 Socket for emergency manual operation lever

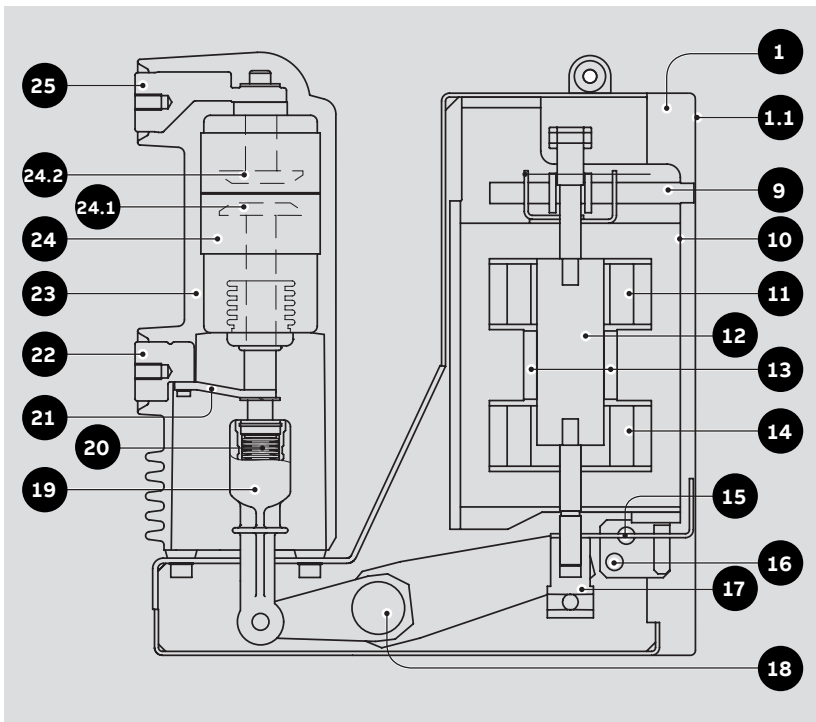

Figure 9/11: Sectional view of a vacuum circuit breaker type VM1-T, schematic diagram.

- | | | | |
|-----|--|------|------------------------|
| 1 | Mechanism enclosure | 18 | Lever shaft |
| 1.1 | Front plate, removable | 19 | Insulated link rod |
| 9 | Emergency manual opening mechanism | 20 | Contact force spring |
| 10 | Magnetic actuator | 21 | Flexible connector |
| 11 | OFF coil | 22 | Lower breaker terminal |
| 12 | Magnet armature | 23 | Cast insulation |
| 13 | Permanent magnets | 24 | Vacuum interrupter |
| 14 | ON coil | 24.1 | Moving contact |
| 15 | Sensor -B0A for "circuit breaker OFF" signal | 24.2 | Fixed contact |
| 16 | Sensor -B0E for "circuit breaker ON" signal | 25 | Upper breaker terminal |
| 17 | Travel adjuster | | |

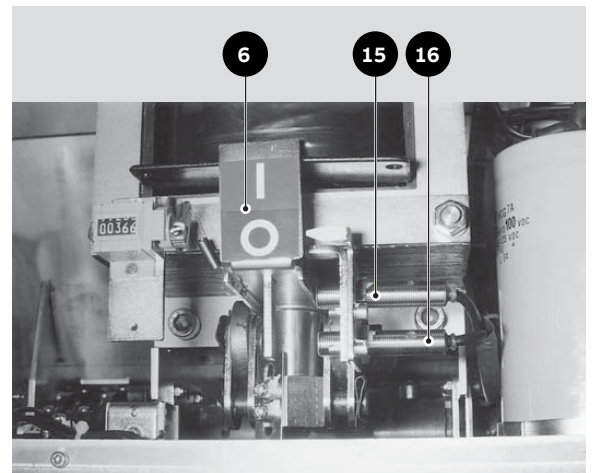
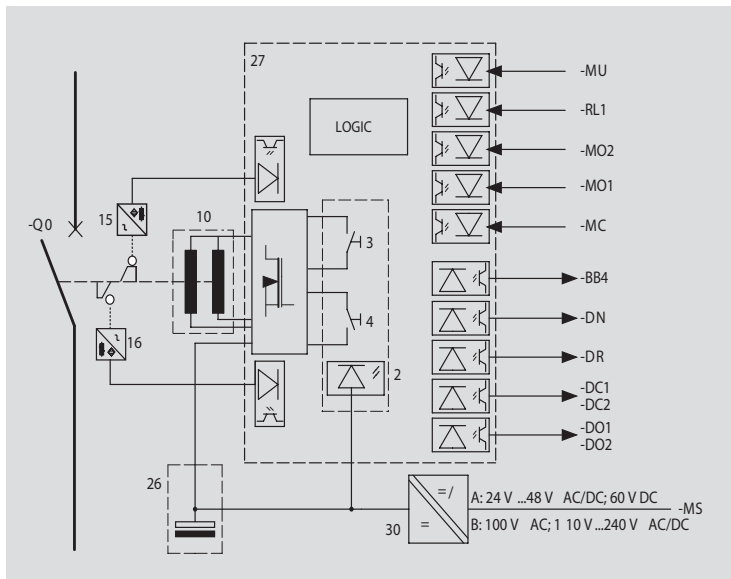

Figure 9/12: Position indicator.

- | | |
|----|--|
| 6 | Mechanical position indicator |
| 15 | Sensor -B0A for "circuit breaker OFF" signal |
| 16 | Sensor -B0E for "circuit breaker ON" signal |

9. Figures



External circuit breaker connection:

Inputs:

- MU Switching command OFF (closed circuit)
- RL1 Closing lock-out (closed circuit)
- MO2 Switching command OFF 2 (open circuit)
- MO1 Switching command OFF 1 (open circuit)
- MC Switching command ON (open circuit)
- MS Supply voltage

Outputs:

- BB4 Fleeting contact (100 ms)
- DN NOT READY (NOC)
- DR READY (NOC)
- DC2 ON signal 2 (NOC)
- DO2 OFF signal 2 (NOC)
- DC1 ON signal 1 (NOC)
- DO1 OFF signal 1 (NOC)

See page 42 for comparison of IEC/VDE designations.

Figure 9/13: Block diagram of the magnetic actuator mechanism.

- 2 "READY" lamp (LED)
- 3 ON push-button
- 4 OFF push-button
- 10 Actuator
- 15 Sensor for "circuit breaker OFF" signal
- 16 Sensor for "circuit breaker ON" signal
- 26 Storage capacitor
- 27 Circuit breaker control unit
- 30 Converter for operation with AC or DC voltage
- Q0 Circuit breaker

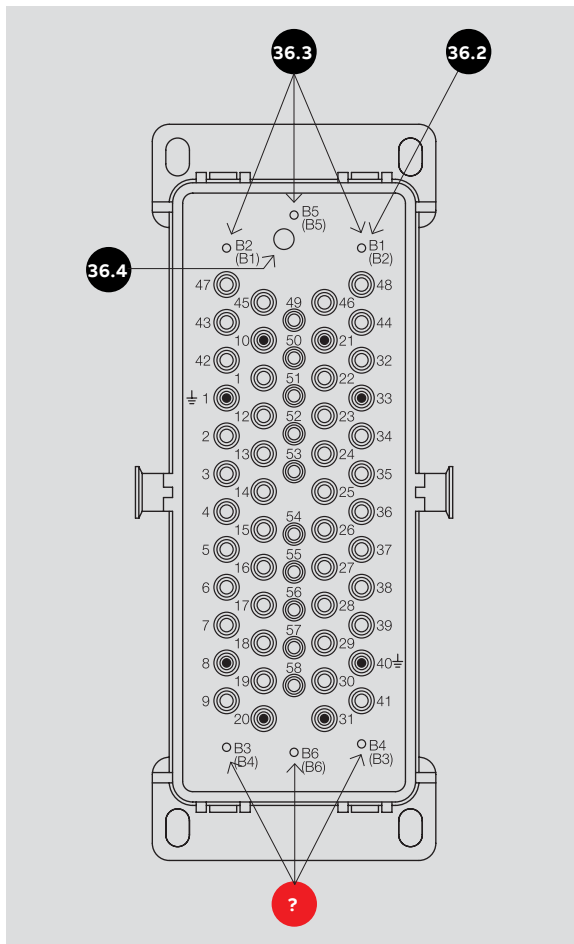

Sample for coding

Control wiring	Code	B1	B2	B3	B4	B5	B6
wiring	Pin		X		X		
socket	Hole						

Control wiring	Hole	X		X			
wiring	Pin						
plug	Code	B1	B2	B3	B4	B5*	B6

* B5 is used in special cases only

Coding:

(...) In brackets is stated the corresponding coding designation for the control wiring plug (1.0.2)

The coding pins can be fitted in the control wiring socket (1.0.1) and/or in the control wiring plug. (1.0.2)

Basic design:

Number of sockets optional, but always with the basic assignment: 1, 8, 10, 20, 21, 31, 33, 40.

Sockets and pins can be mixed in the control wiring socket (1.0.1) and control wiring plug (1.0.2) as required

Figure 9/14: Possible encoding of the control wiring plug connector, 58-way control wiring socket.
 36.2 Control wiring socket
 36.3 Centres for coding pins and bores
 36.4 Bore for the actuating pin on the control wiring plug for controlling the auxiliary switch.

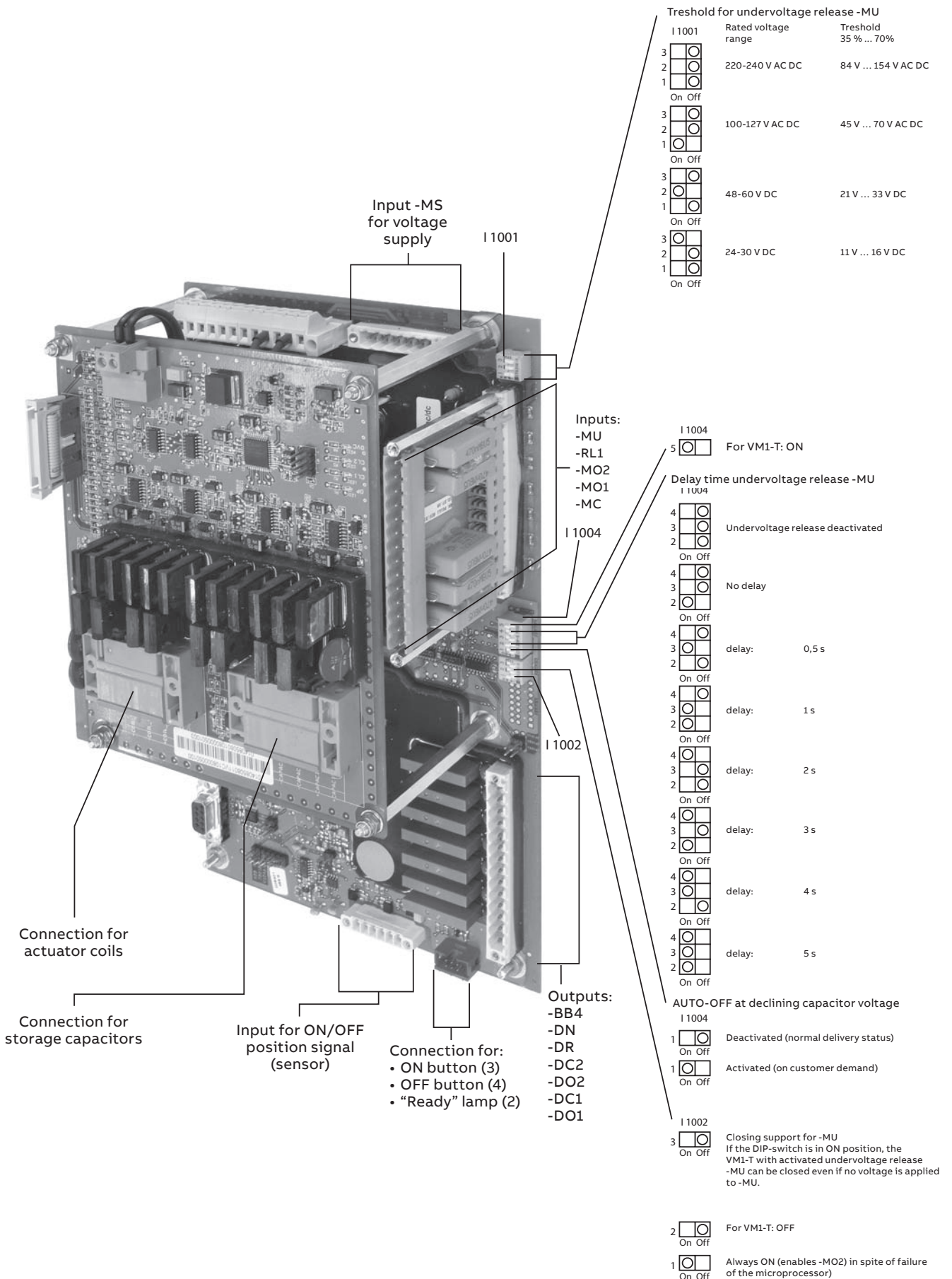

Figure 9/15 a: Circuit breaker control unit
Note: Some changes to the settings of the DIP-switches (section 7.1) to become effective.

9. Figures

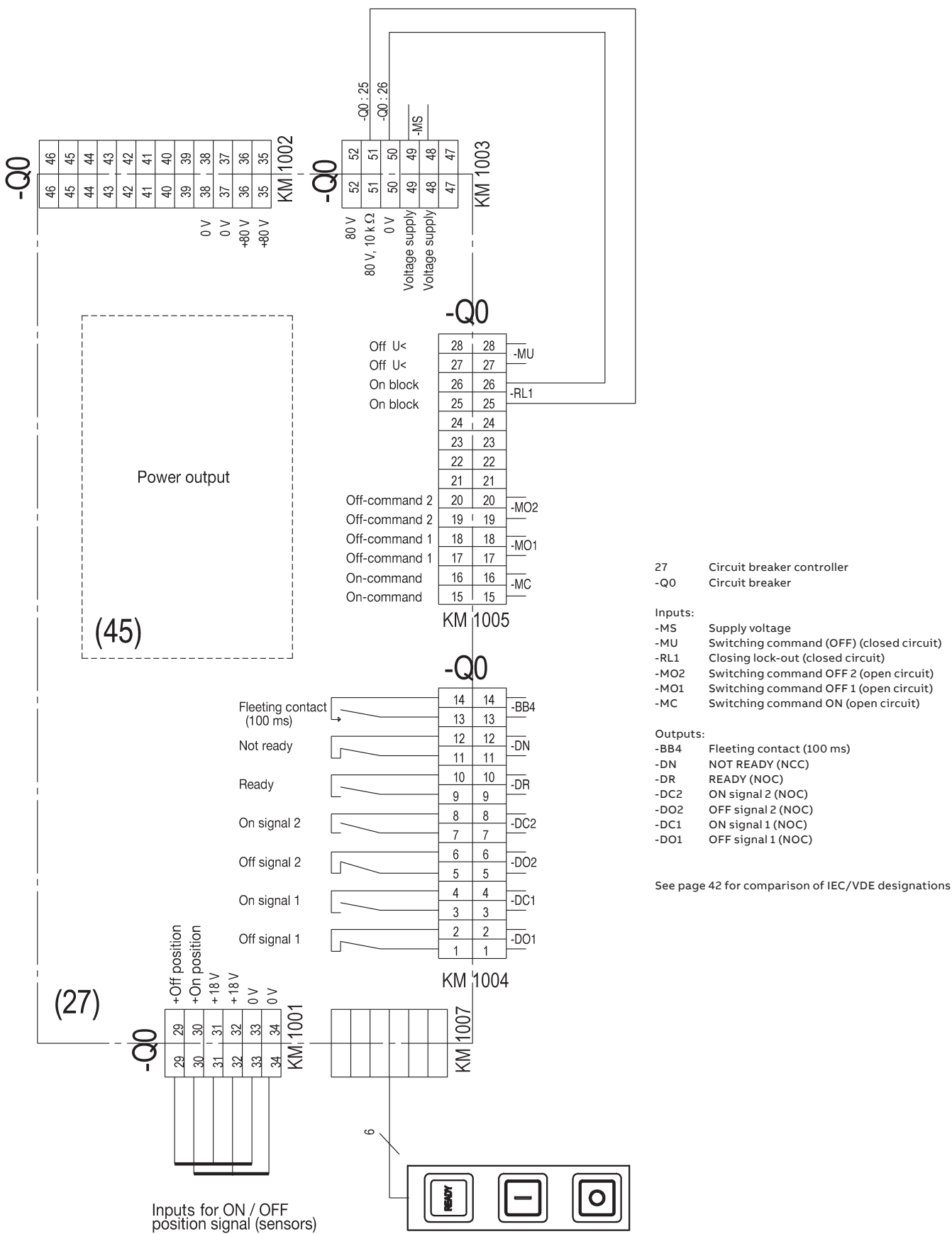

Figure 9/15b: Terminal diagram for circuit breaker for fixed installation (without plug wiring).

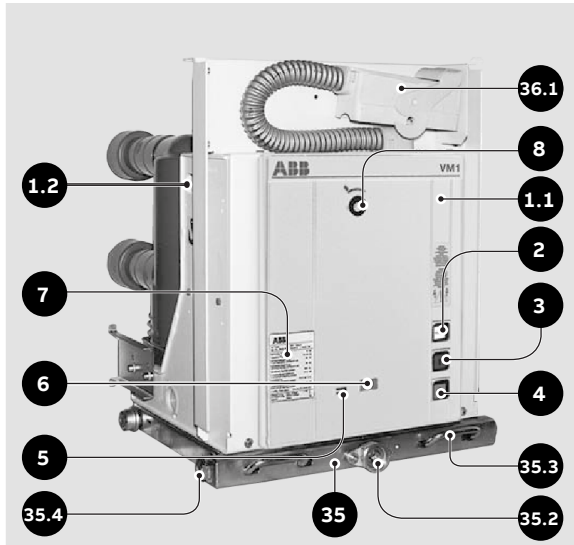

Figure 9/16: Front of circuit breaker with indicators and controls

- 1.1 Front plate
- 1.2 Bore for handling, both sides
- 2 "READY" lamp
- 3 ON push-button
- 4 OFF push-button
- 5 Mechanical operating cycle counter
- 6 Mechanical position indicator
- 7 Rating plate
- 8 Recess for emergency manual opening lever
- 35 Withdrawable assembly
- 35.2 Square spigot for hand crank 38
- 35.3 Sliding handle
- 35.4 Catch
- 36.1 Control wiring plug

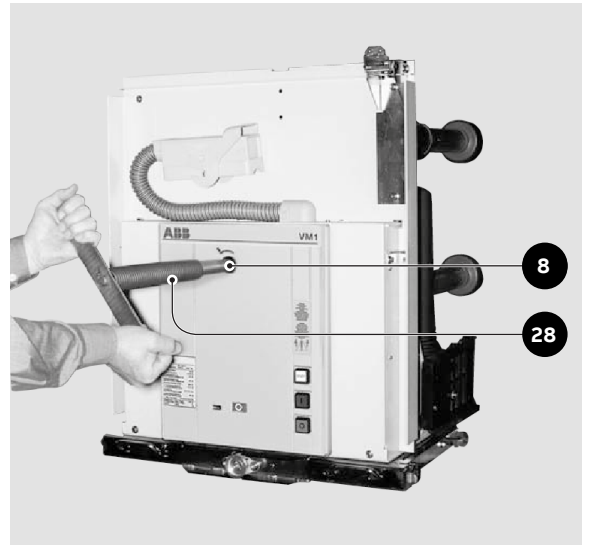

Figure 9/17: Emergency manual switch-off

- 8 Recess for emergency manual opening lever
- 28 Emergency manual opening lever

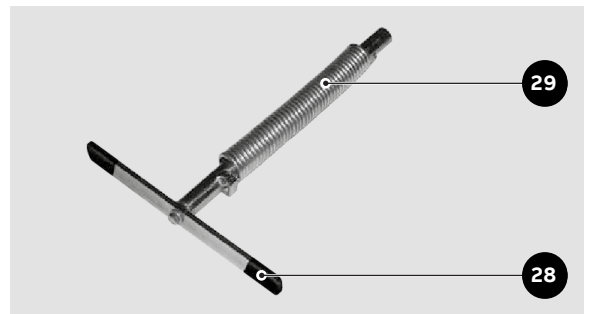

Figure 9/19: Emergency manual opening lever

- 28 Emergency manual opening lever
- 29 Spring to secure the opening capacity

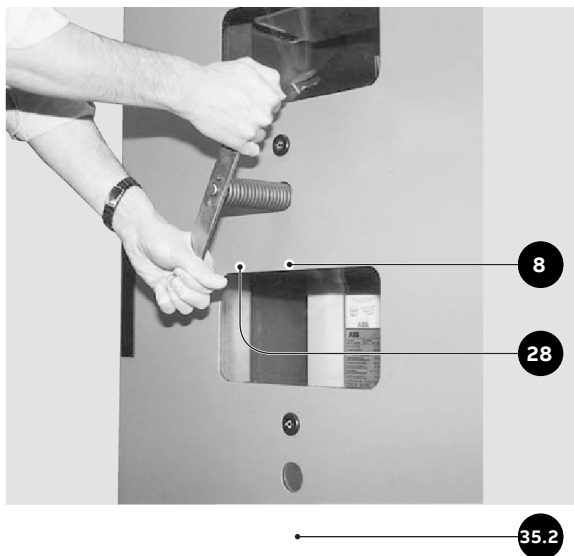

Figure 9/18: Emergency manual switch-off of a VM1-T circuit breaker with panel door closed, example.

- 8 Recess for emergency manual opening lever
- 28 Emergency manual opening lever
- 35.2 Square spigot for hand crank 38



Figure 9/20: Moving the circuit breaker on a withdrawable part between the test/disconnected position and the service position; clockwise up to the stop for the service position and anticlockwise for the test/disconnected position. Example of a panel.

- 38 Hand crank

9. Figures



Figure 9/21: Withdrawal of the withdrawable part with circuit breaker onto the service truck.
 - Service truck engaged with the panel
 - Move the sliding handles inwards to disengage
 31 Withdrawable part with VM1-T circuit breaker
 35.3 Sliding handle
 40 Service truck

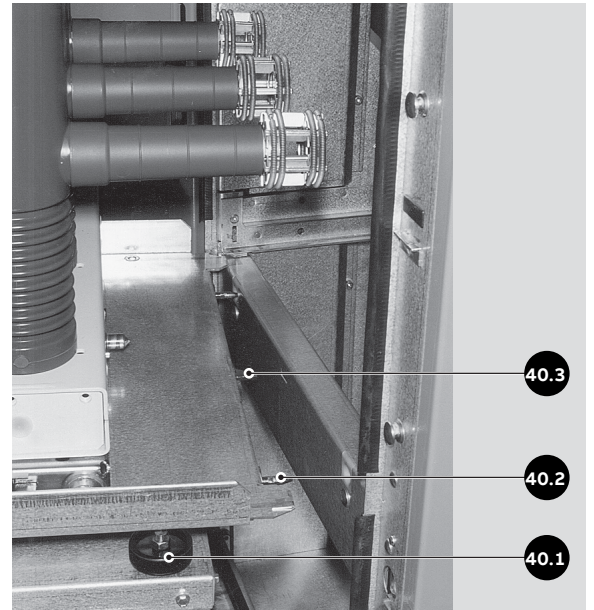

Figure 9/22: Service truck approaching the panel. Align the guide pins on the load surface with the height adjusters, position the truck atch to engage.
 40.1 Height adjuster for the load surface
 40.2 Guide pin
 40.3 Catch

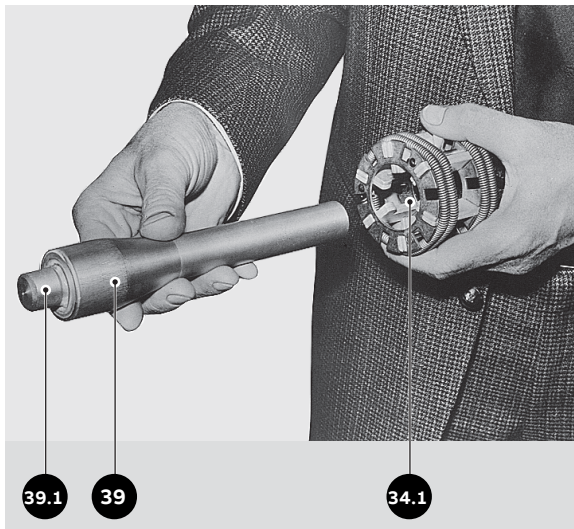

Figure 9/23: Fit the contact system back-to-front on the thin end of the arbor and slide it onto the thicker shank area.
 34.1 Contact system
 39 Arbor
 39.1 Journal

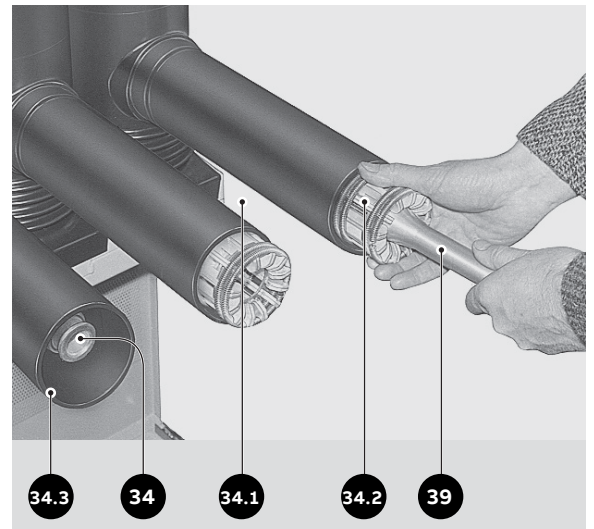

Figure 9/24: Slide the contact system over from the arbor onto the contact arm and allow it to engage there.
 34 Contact arm
 34.1 Contact system
 34.2 Internal tension springs
 34.3 Insulating sleeve
 39 Arbor

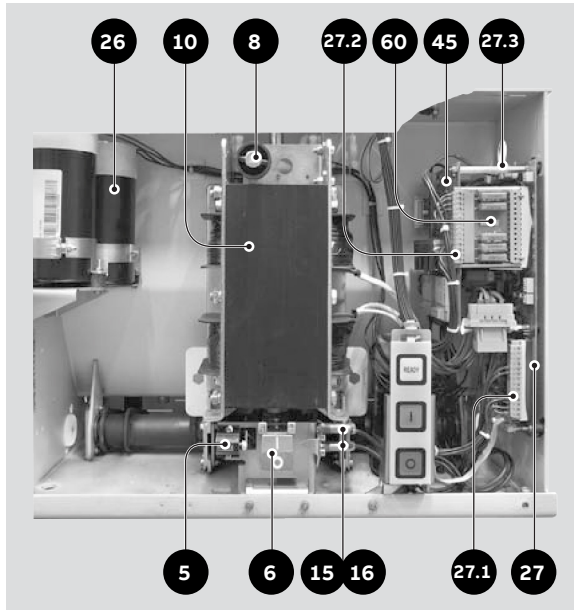

Figure 9/25: View of the operating mechanism of the VM1-T circuit breaker with auxiliary devices, front plate removed.

- 5 Mechanical operating cycle counter
- 6 Mechanical position indicator
- 8 Receptacle for emergency manual opening lever
- 10 Magnetic actuator
- 15 Sensor for "circuit breaker OFF" signal (top)
- 16 Sensor for "circuit breaker ON" signal (bottom)
- 26 Storage capacitors
- 27 Circuit breaker control unit
- 27.1 Plug connector for outputs -BB4, -DR, -DN, -DO1, -DC1
- 27.2 Plug connector for supply voltage
- 27.3 Plug connector for inputs (filter card not shown)
- 45 Power output
- 60 Filter card

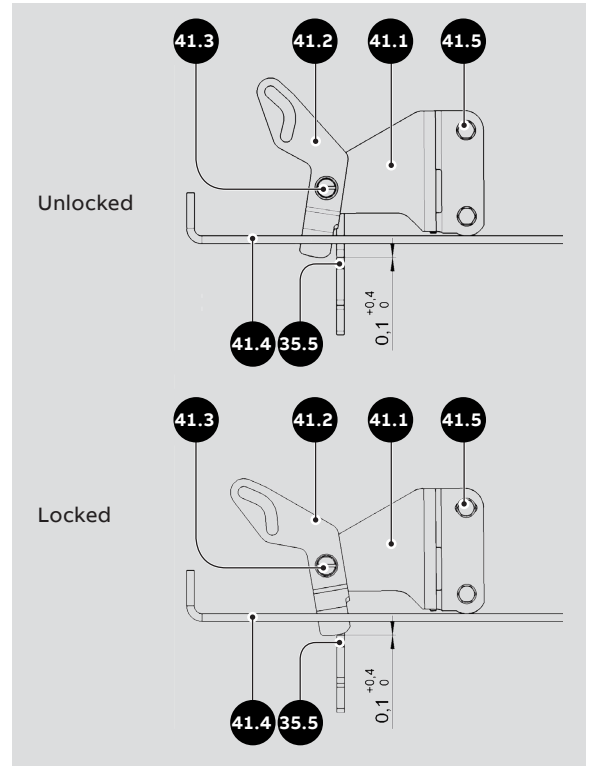

Figure 9/26: Mechanical interlock between the withdrawable assembly and the circuit breaker, setting of the slide blocker.

View from front

- 35.5 Pawl in the withdrawable assembly
- 41.1 Fixing sheet
- 41.2 Slide blocker
- 41.3 Revolute joint
- 41.4 Base plate of the circuit breaker
- 41.5 Screw

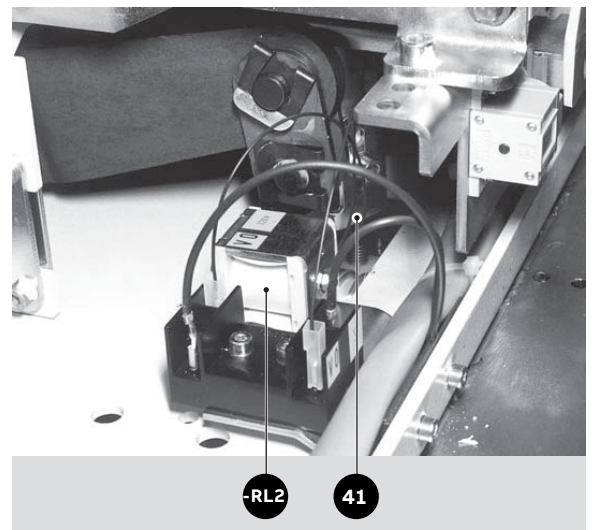

Figure 9/27: Manually movable withdrawable part, front plate removed.

- RL2 blocking magnet for the withdrawable part (only on manually movable parts)
- 41 Mechanical interlock between the withdrawable assembly and the circuit breaker

10. Technical data

10.1 Technical data, general

10.1.1 Technical data Control electronics

a) Binary inputs

The following applies to all 5 input channels:

- Electrical isolation between all inputs and from the electronics: 2.0 kV AC
- AC/DC operation (any polarity for DC)
- Response range at inputs -MO1, -MC und -MO2, according to the type of filter card 1):
 - 24 V^{-15%} ... 60 V^{+15%} AC
 - 24 V^{-30%} ... 60 V^{+15%} DC
 - 100 V^{-15%} ... 125 V^{+15%} AC
 - 100 V^{-30%} ... 125 V^{+15%} DC
 - 220 V^{-15%} ... 240 V^{+15%} AC
 - 220 V^{-30%} ... 240 V^{+15%} DC
- Response range -MU²⁾ adjustable, see page 26
- Response range -RL1:
 - 24 V^{-15%} ... 240 V^{+15%} AC
 - 24 V^{-30%} ... 240 V^{+15%} DC
- Base load at input:
 - 300 kΩ (-MU²⁾, -RL1, -MO²⁾ ³⁾
 - 14 kΩ (-MO1, -MC)
- Inputs protected from voltage surges.

b) Binary outputs

The following applies to all 5 output channels:

- Electrical isolation between all outputs and from the electronics: 2.0 kV AC
- Switching voltage: max. 400 V AC or 300 V DC
- Switching current: max. 6 A / 250 V AC (resistive)
- ON resistance: 100 mΩ
- Switch outputs: NOC, NCC and fleeting contact
- Duration of fleeting contact pulse: 100 ms
- Output connections: varistors

(1) Different response ranges for individual inputs on request.

(2) Full version on the control module

(3) In general, with AC signals which are connected via long lines, it should be checked whether the installed base load of 300 kΩ is sufficient (mutual capacitive coupling!) to ensure a reliably low interference level. Otherwise, an appropriately dimensioned resistor or capacitor is to be connected in parallel at the input terminals.

10.1.2 Technical data

AC/DC converter

- Input voltage ranges, optional:
 - Power pack A:
 - 24 V^{-15%} ... 48 V^{+15%} AC
 - 24 V^{-15%} ... 60 V^{+15%} DC
 - Power pack B:
 - 100 V^{-15%} ... 240 V^{+10%} AC
 - 110 V^{-15%} ... 240 V^{+10%} DC
- Protection of power feed (must be ordered):
 - Power pack A:
 - ABB-Stotz m.c.b.: S 282 UC-K; 1.6 A
 - Power pack B:
 - ABB-Stotz m.c.b.: S 282 UC-K; 1.0 A
- Power consumption on the input side during a charging process: ca. 100 W
- Power consumption in normal position: P < 10 W
- Charging times of the capacitor (example for DC voltage):
 - a) Initial charging on commissioning:
 - Breakers up to 25 kA: max. 20s depending on the supply voltage.
 - In this time, the capacitor(s) is/are charged to 80 V, and an ON-OFF operating cycle is already possible at 69 V. (The "READY" lamp indicates readiness for switching. A flashing "READY" lamp signals recharging of the capacitor. Switching readiness is enabled during that time).
 - b) Recharging after a switch operation to a charge of 80 V: max. 10s

10.1.3 Permissible number of vacuum interrupter operating cycles

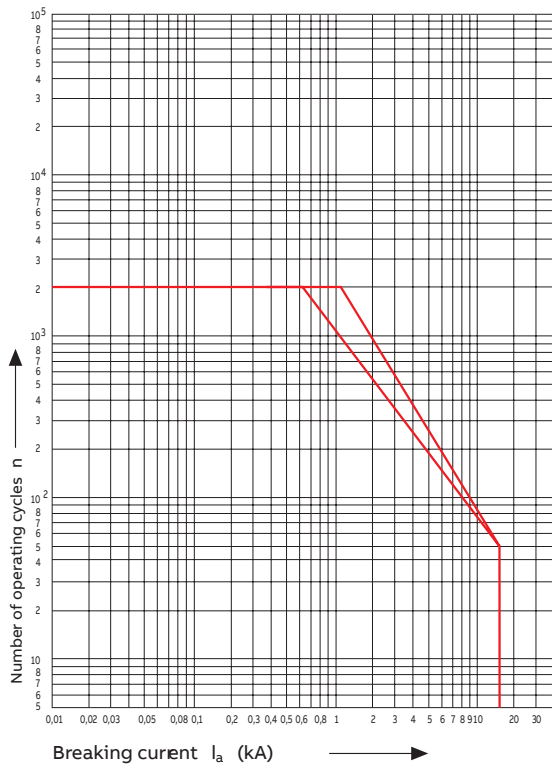

Diagram A)

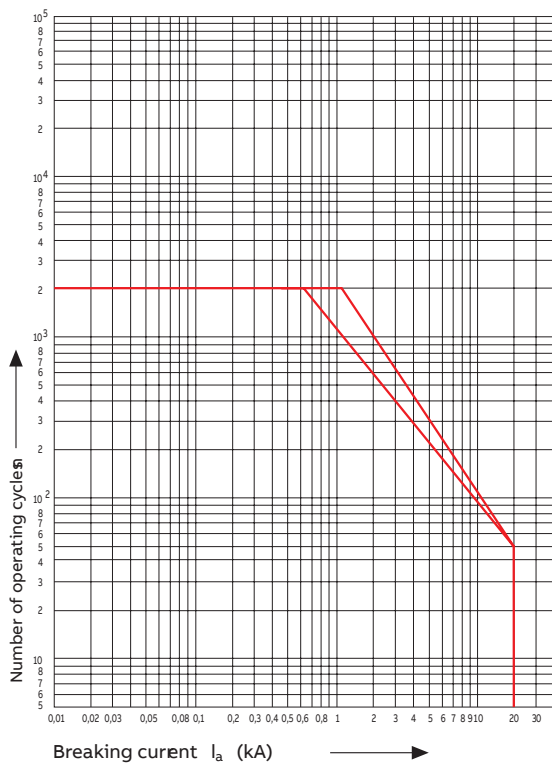

Diagram B)

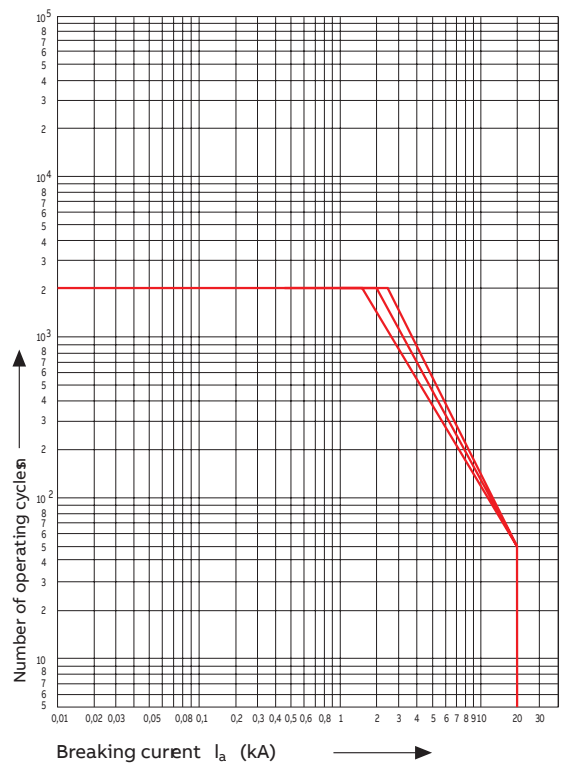

Diagram C)

10. Technical data

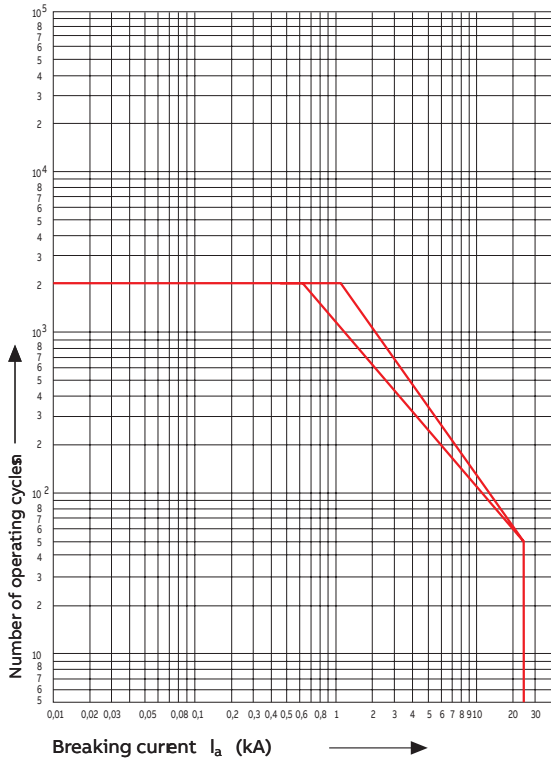

Diagram D)

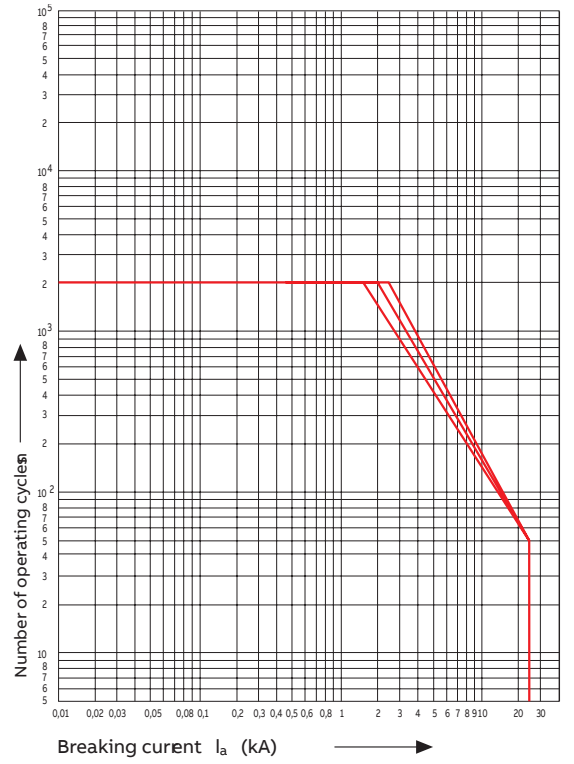

Diagram E)

Figure 9/28: Permissible number of vacuum interrupter operating cycles as a function of the breaking current I_a . (Reference see section 10.2 and 10.3 – Technical data page 33 and 36)

10.2 Technical data

Circuit breakers for fixed installation

10.2.1 Performance data and weights

Rated voltage	kV	12	17.5	24
Rated frequency	Hz	50/60	50/60	50/60
Rated lightning impulse withstand voltage	kV	75	95	125
Rated power frequency withstand voltage	kV	28	38	50
Rated of rise of transient recovery voltage	kV/ μ s	0.34	0.42	0.47
Peak transient recovery voltage	kV	20.6	30	41
Rated operating sequence		O-3 min-CO-3 min-CO		
Rated operating sequence for autoreclosing		O-0.3 s-CO-3 min-CO		

Guideline values for function times:	kV
Closing time	approx. 16 ms
Opening time	approx. 10 ms
Arcing duration (at 50 Hz)	≤ 15 ms
Total opening time	≤ 25 ms
Minimum command time on closing	2 ms
Minimum command time on opening	2 ms

Breaker type	Rated voltage	Rated current	Rated short-circuit breaking current symm. (1)	Pole centres	Weight (2)	Permissible of vacuum-interrupter switching operations
VM1-T	kV	A	kA	mm	approx. kg	Figure 9/28 page 32
1212-20	12	1250	20	210	90/95	Diagram B
1220-20		2000		210/275	135/140	Diagram C
1212-25	12	1250	25	210	90/95	Diagram D
1220-25		2000		210/275	135/140	Diagram E
1720-25	17.5	2000	25	210/275	135/140	Diagram E
2412-20	24	1250	20	210	100/105	Diagram B
2412-25	24	1250	25	275	100/105	Diagram D

(1) At operating voltages lower than the rated voltage, the same values fundamentally apply as for the rated voltage. Higher values on request.

(2) Individual unit without truck

10. Technical data

10.2.2 Dimensions

Circuit breaker for fixed installation

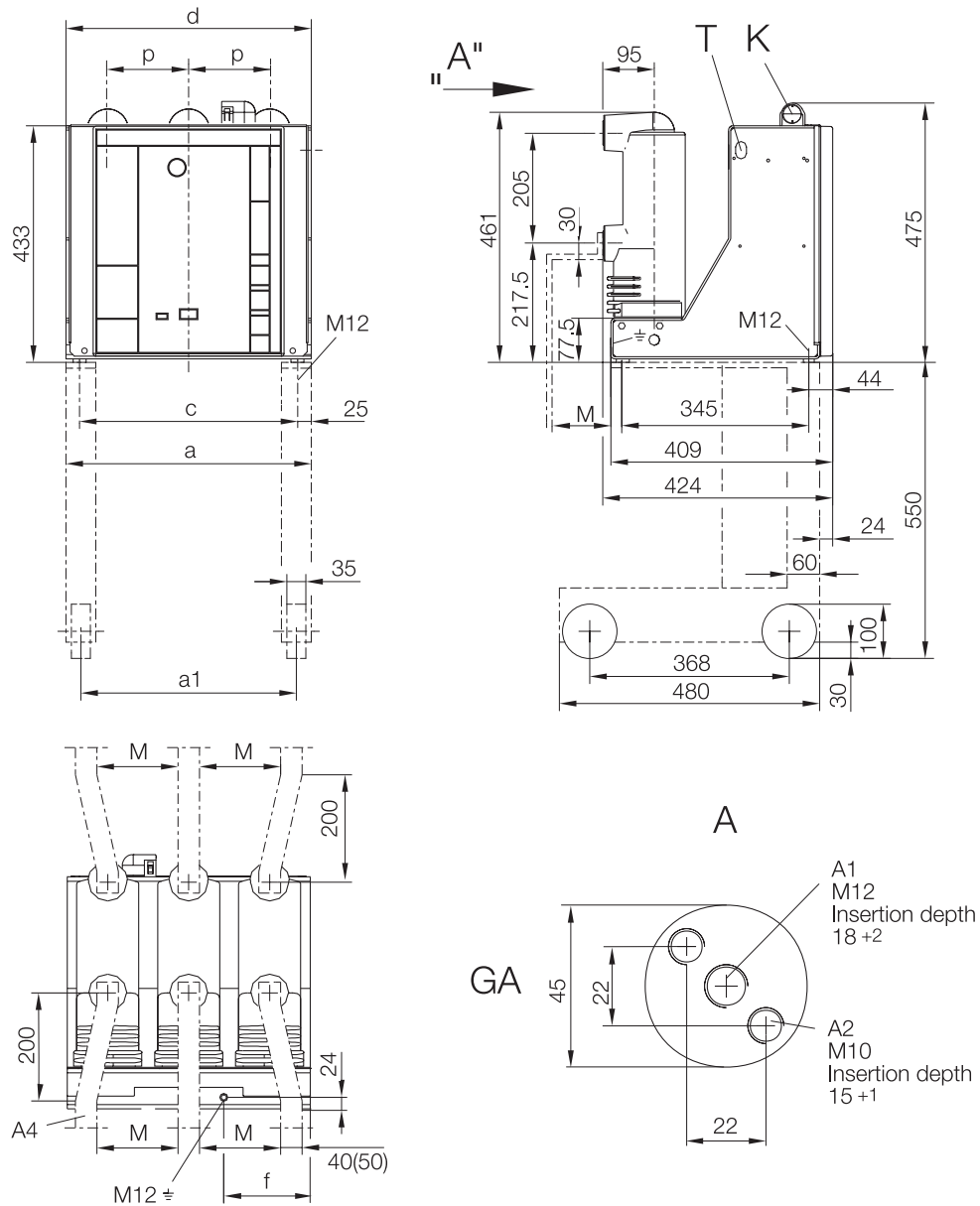

K = Cable entry
 T = Transport bore, both sides
 A = Detail "A"
 GA = Tested connection zone
 M = Minimum clearance to DIN VDE 0101

A1 = Terminal for 630 A
 A2 = Terminal for 1250 A
 A4 = Connecting bar to DIN 46 433, for 17.5 kV with shrink-on sleeve
 ⊕ = PE conductor terminal, use contact washer

Rated voltage	Rated current	Rated short-circuit breaking current							
kV	A	kA	p	a	a1	c	d	f	
12 / 17.5	630 / 1250	... 25	150	450	395	400	450	160	
			210	570	515	520	570	220	

Figure 10/1: Dimensional drawing of circuit breaker type VM1-T:
- 12 / 17.5 kV, 630 A und 1250 A, ... 25 kA

10. Technical data

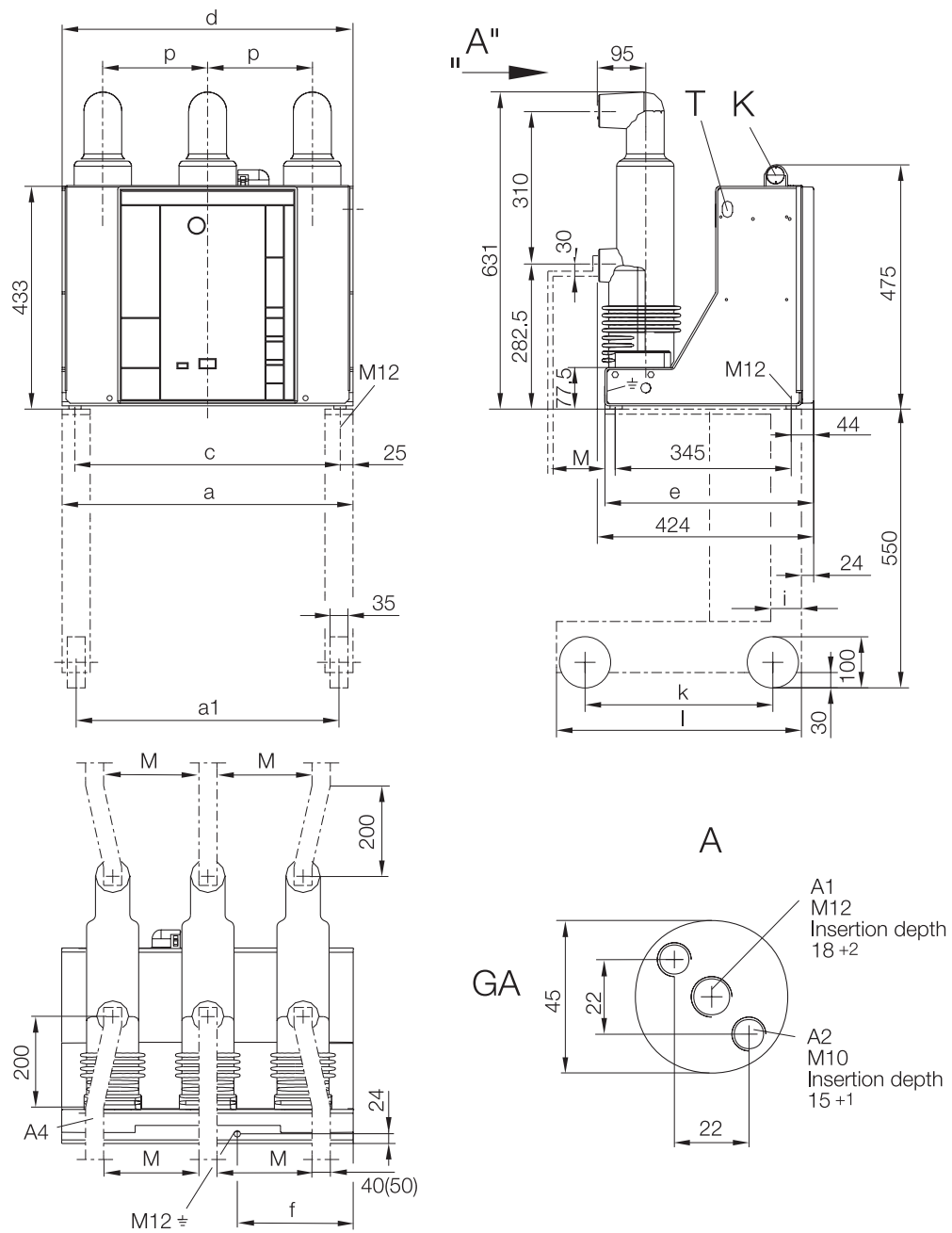

K = Cable entry
 T = Transport bore, both sides
 A = Detail "A"
 GA = Tested connection zone
 M = Minimum clearance to DIN VDE 0101

A1 = Terminal for 630 A
 A2 = Terminal for 1250 A
 A4 = Connection bar to DIN 46 433, for 17.5 kV with shrink-on sleeve
 ⊕ = PE conductor terminal, use contact washer

Rated voltage	Rated current	Rated short-circuit breaking current	p	a	a1	c	d	f	p	e	i	k	l
24	630 / 1250	... 25	210	570	515	520	570	220	210	409	60	368	480
			275	750	695	700	750	545	275	428	50	530	670

Figure 10/3: Dimensional drawing of circuit breaker type VM1-T:
 - 24 kV, 630 A and 1250 A, ... 25 kA

10.3 Technical data

Circuit breakers on withdrawable part ⁽¹⁾

10.3.1 Performance data and weights

Rated voltage	kV	12	17.5	24
Rated frequency	Hz	50/60	50/60	50/60
Rated lightning impulse withstand voltage	kV	75	95	125
Rated power frequency withstand voltage	kV	28	38	50
Rated of rise of transient recovery voltage	kV/ μ s	0.34	0.42	0.47
Peak transient recovery voltage	kV	20.6	30	41
Rated operating sequence		O-3 min-CO-3 min-CO		
Rated operating sequence for autoreclosing		O-0.3 s-CO-3 min-CO		

Guideline values for function times:

Closing time	approx. 16 ms
Opening time	approx. 10 ms
Arcing duration (at 50 Hz)	\leq 15 ms
Total opening time	\leq 25 ms
Minimum command time on closing	2 ms
Minimum command time on opening	2 ms

Breaker type	Rated voltage	Rated current	Rated short-circuit breaking current symm. ⁽²⁾	Short-circuit breaking current asymm. ⁽²⁾	Rated short-circuit making current (peak) ⁽²⁾	Rated short-circuit duration	Pole centres ⁽¹⁾	Weight ⁽²⁾ ⁽¹⁾ ⁽³⁾	Permissible of vacuum-interrupter switching operations
VM1-T	kV	A	kA	kA	kA	s	mm	approx. kg	Figure 9/28 page 31/32
1212-16	12	1250	16				150	131	Diagram A
1212-20		1250	20				150	131	Diagram B
1216-20		1600					210	135/140	Diagram C
1206-25		630	25	27.3	63	3	150	127	Diagram D
1212-25		1250					150	131	Diagram D
1216-25		1600					210	135/140	Diagram E
1220-25		2000					210	135/140	Diagram E
2412-20	24	1250	20				210	142/1407	Diagram B

⁽¹⁾ For further details on the cell type assignments see the section on dimensions for circuit breaker on withdrawable assembly.

⁽²⁾ At operating voltages lower than the rated voltage, the same values fundamentally apply as for the rated voltage. Higher values on request.

⁽³⁾ With a motorized withdrawable part, the weight is increased by approx. 2 kg

10. Technical data

10.3.2 Dimensional drawings

Circuit breakers on withdrawable part

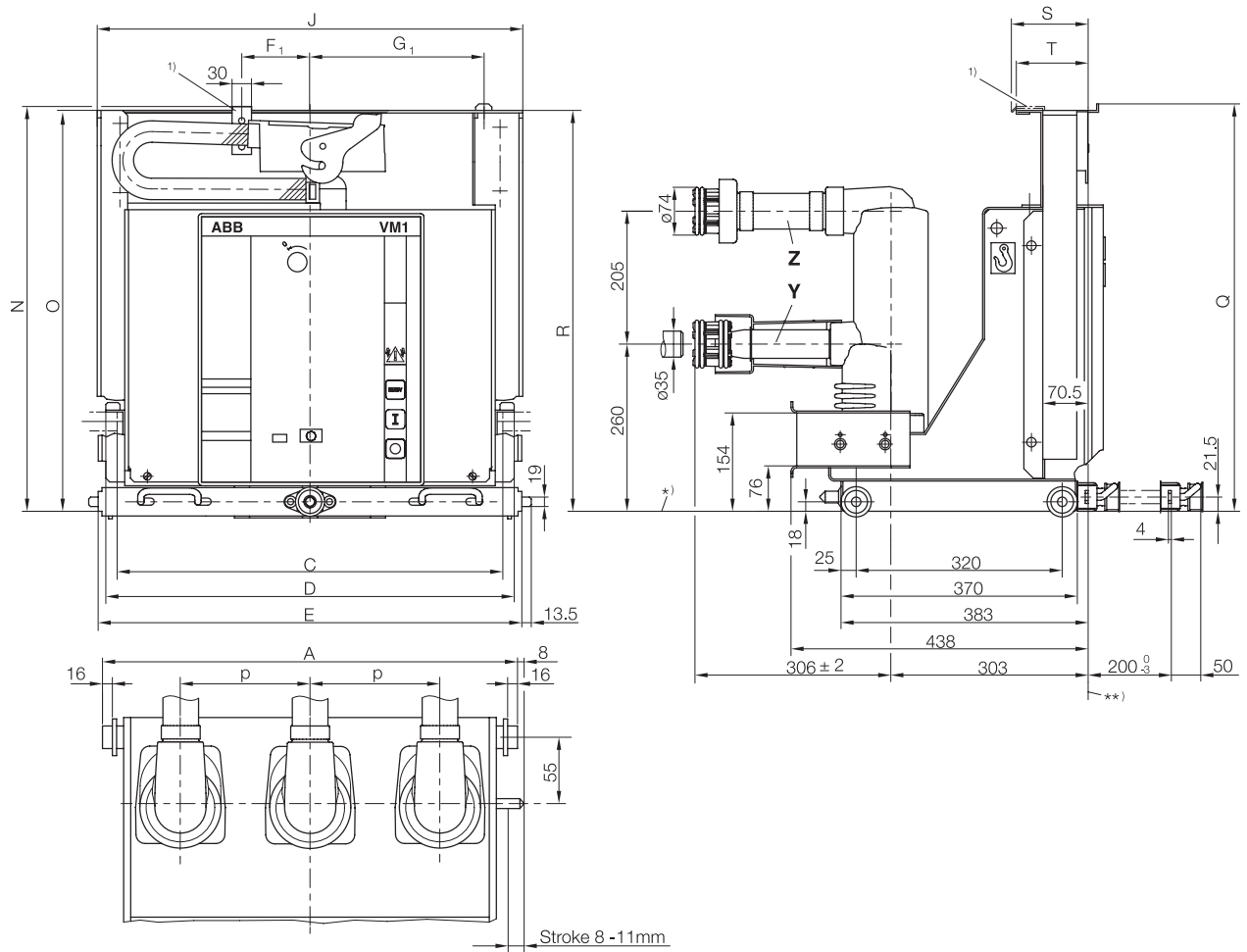

*) Travel rail

**) Front edge of bolt

(1) Only fitted if BT1/BT2 is configured in the panel.

(2) Versions for up to 630 A (with insulating tube)

(3) Versions for 1250 A upwards (with shrink sleeve)

(4) For motor-operated withdrawable parts, the weight is increased by approx. 2 kg.

Table 1:

Panel type	Parameters 12 kV	Parameters breaking 17.5 kV	p	A	C	D	E	J	Y ⁽²⁾	X ⁽³⁾	Weight ⁽⁴⁾ approx. kg
UniGear type ZS1	630 A, ... 25 kA	630 A, ... 25 kA	150	502	466	490	503	492	X	-	127
	1250 A, ... 25 kA	1250 A, ... 25 kA	150	502	466	490	503	492	-	X	131

Table 2:

UniGear type ZS1	p	N	O	Q	R	S	T	F ₁	G ₁
	150	624±2	618	628	620±2	128±1	120±1	30±1	203±1

Figure 10/4: Vacuum circuit breaker on withdrawable part, type VM1-T:

- Use in UniGear type ZS1
- 12 kV, ... 1250 A, ... 25 kA
- 17.5 kV, ... 1250 A, ... 25 kA

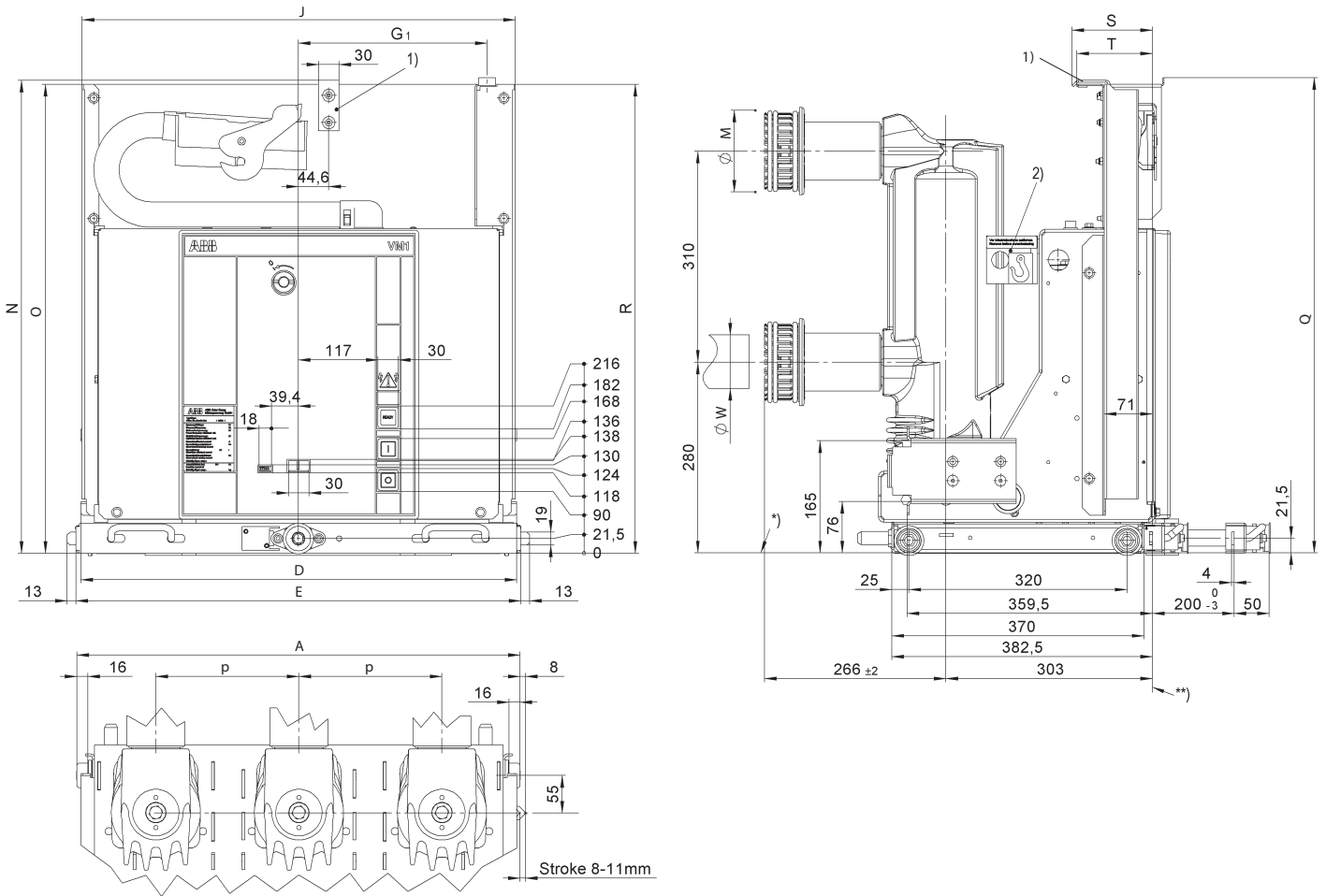

- *) Rail
- **) Front edge of bar
- (1) Only fitted if BT1/BT2 is configured in the panel.
- (2) Remove the lifting lugs on both sides before commissioning.
- (3) Weight is increased by approx. 2 kg if the motor-driven withdrawable part is installed.

Table 1:

Panel type	Parameters 12 kV	Parameters 17.5 kV	p	A	C	D	E	J	M	W	Weight (3) approx. kg
UniGear type ZS1	1600 A, ... 25 kA	1600 A, ... 25 kA	210	650	618	640	653	636	120	79	215
	1600 A, ... 25 kA	1600 A, ... 25 kA	275	850	812	836	853	844	120	79	220
	2000 A, ... 25 kA	2000 A, ... 25 kA	210	650	618	640	653	636	120	79	215
	2000 A, ... 25 kA	2000 A, ... 25 kA	275	850	812	836	853	844	120	79	220

Table 2:

	p	N	O	Q	R	S	T	G ₁
UniGear type ZS1	210	691±2	688	698	688±2	119	111±1	273±2
	275	691±2	688	698	688±2	119	111±1	273±2

Figure 10/5: Vacuum circuit breaker on withdrawable part, type VM1-T:
 - Use in UniGear type ZS1
 - 12 kV, 1600 ... 2000 A, ... 25 kA
 - 17.5 kV, 1600 ... 2000 A, ... 25 kA

10. Technical data

10.3.3 Wiring diagrams for C.B. on withdrawable part

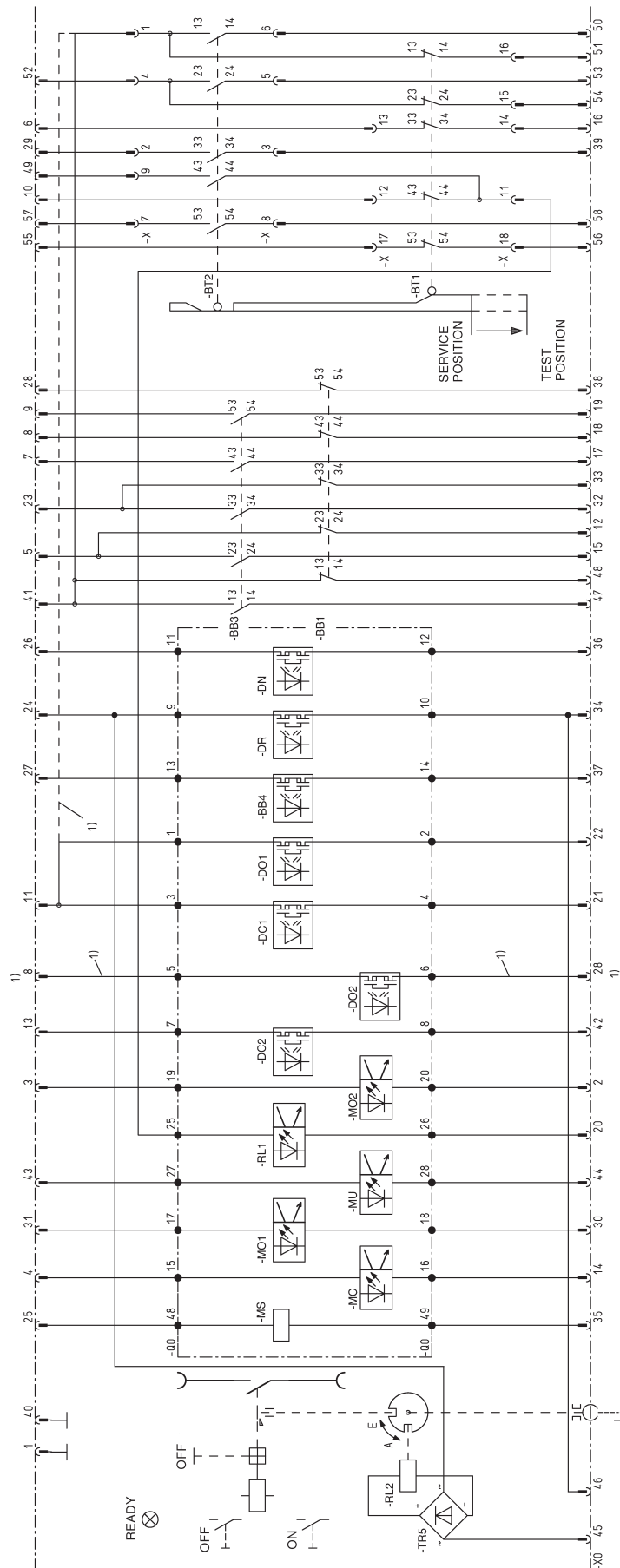

Note:

The wiring diagrams comprise the basic components and all further equipment options for the various VM1 types. The scope of equipment possible within an individual type series is listed in the relevant switchgear list, and the equipment fitted in each individual case can be found in the order documentation.

- MS Supply voltage
- RL2 Blocking magnet for withdrawable part with rectifier -TR5
- RL1 Closing lock-out (closed circuit)
- MO1 Switching command OFF 1 (open circuit)
- MC Switching command ON (open circuit)
- MU Switching command OFF (closed circuit)
- MO2 Switching command OFF 2 (open circuit)
- BB1 Auxiliary switch on the actuating shaft
- BB3 Auxiliary switch on the actuating shaft
- BB4 Fleeting contact (100 ms)
- BT2 Limit switch for withdrawable part in test position
- BT1 Limit switch for withdrawable part in service position
- DR READY for operation (NOC)
- DN NOT READY for operation (NCC)
- DO1 OFF signal (NOC)
- DC1 ON signal (NOC)
- DO2 OFF signal (NOC) (Full version)
- DC2 ON signal (NOC) (Full version)

Mode of presentation:

(¹⁾ Connection exists when auxiliary switches -BB1 and -BB3 are not used.

See page 42 for comparison of IEC/VDE designations.

Note:

If the READY contact -DR is to be polled, the wiring diagram of the panel should include the information that this contact is already connected to blocking magnet -RL2 and is therefore not isolated.

Figure 10/7: Wiring diagramm for VM1-T vacuum circuit breaker on manually movable withdrawable assembly:
 - Maximal of equipment
 - Control wiring plug 58-pole
 - Use in panel system UniGear-Typ ZS1

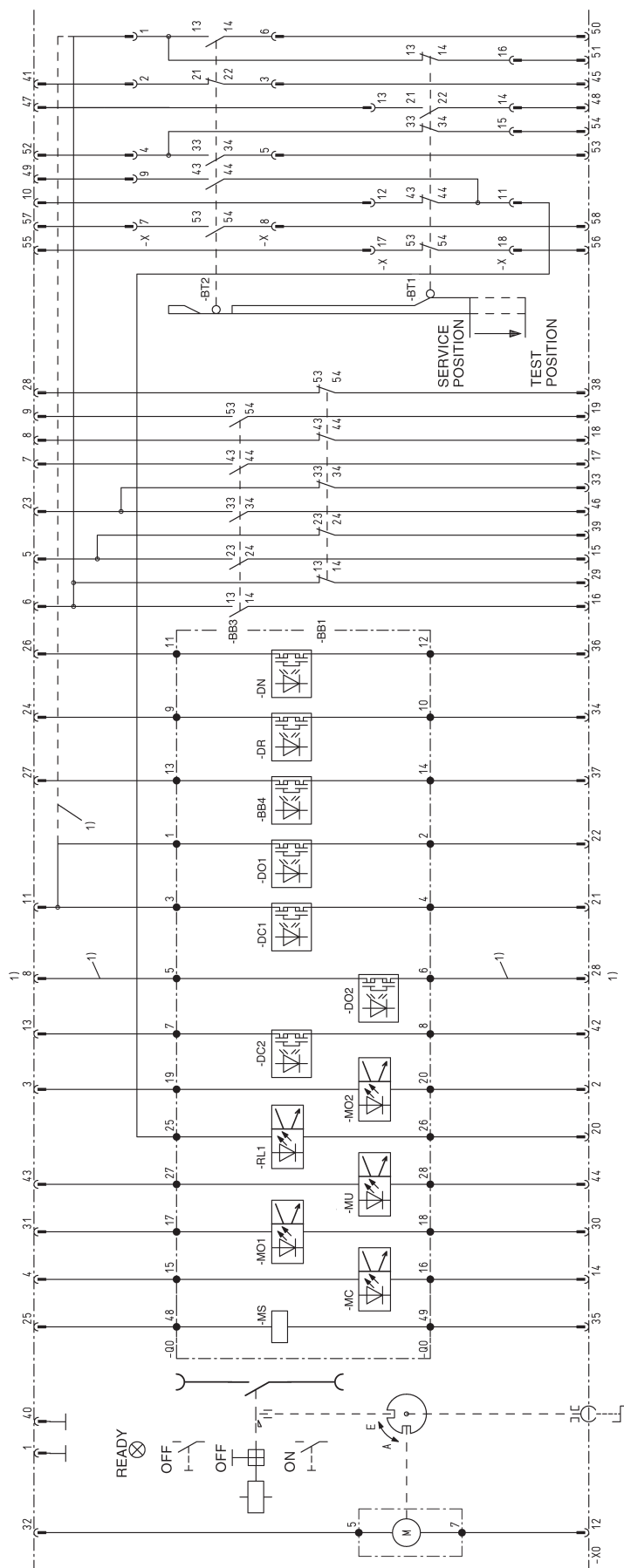

- MS Supply voltage
- RL1 Closing lock-out (closed circuit)
- MO1 Switching command OFF 1 (open circuit)
- MC Switching command ON (open circuit)
- MU Switching command OFF (closed circuit)
- MO2 Switching command OFF 2 (open circuit)
- BB1 Auxiliary switch on the actuating shaft
- BB3 Auxiliary switch on the actuating shaft
- BB4 Fleeting contact (100 ms)
- BT2 Limit switch for withdrawable part in test position
- BT1 Limit switch for withdrawable part in service position
- DR READY for operation (NOC)
- DN NOT READY for operation (NCC)
- DO1 OFF signal (NOC)
- DC1 ON signal (NOC)
- DO2 OFF signal (NOC) (Full version)
- DC2 ON signal (NOC) (Full version)

Mode of presentation:

- (1) Connection exists when auxiliary switches -BB1 and -BB3 are not used.

See page 42 for comparison of IEC/VDE designations.

Figure 10/8: Wiring diagram for VM1-T vacuum circuit breaker on motor-driven withdrawable assembly:
 - Maximum of equipment
 - Control wiring plug 58-pole
 - Use in panel system UniGear type ZS1

11. Comparison of designations to IEC 61346-1 / 61346-2, IEC 81346-1 / 81346-2 and VDE-DIN 40719 Part 2

Description	IEC 61346-1 / 61346-2	IEC 81346-1 / 81346-2	VDE DIN 40719 Part 2
Blocking magnet for withdrawable part with rectifier -TR5	-RL2	-RLE2	-Y0
Closing lock-out (closed circuit)	-RL1	-RLE1	-Y1
Switching command OFF 1 (open circuit)	-MO1	-MBO1	-Y2
Switching command ON (open circuit)	-MC	-MBC	-Y3
Switching command OFF (closed circuit)	-MU	-MBU	-Y4
Switching command OFF 2 (open circuit)	-MO2	-MBO2	-Y9
Auxiliary switch on the actuating shaft	-BB1	-BGB1	-S3
Auxiliary switch on the actuating shaft	-BB3	-BGB3	-S5
Fleeting contact (100 ms)	-BB4	-BGB4	-S7
Limit switch for withdrawable part in test position	-BT2	-BGT2	-S8
Limit switch for withdrawable part in service position	-BT1	-BGT1	-S9
READY for operation (NOC)	-DR	-BGB31	-S11
NOT READY for operation (NCC)	-DN	-BGB32	-S12
OFF signal (NOC)	-DO1	-BGB41	-S41
ON signal (NOC)	-DC1	-BGB42	-S42
OFF-Signal (NOC) (Full version)	-DO2	-BGB43	-S43
ON-Signal (NOC) (Full version)	-DC2	-BGB44	-S44
Supply voltage	-MS	-MAS	-M0

ABB S.p.A.
Electrification Products Division
Medium Voltage Products

Via Friuli, 4
I-24044 Dalmine
Tel.: +39 035 6952 111
Fax: +39 035 6952 874
E-mail: info.mv@it.abb.com

ABB AG
Calor Emag Medium Voltage Products

Oberhausener Strasse 33	Petzower Strasse 8
40472 Ratingen	14542 Werder (Havel) OT Glindow
GERMANY	GERMANY
Tel.: 02102 12-0	
Fax: 02102 12-17 77	
E-Mail: powertech@de.abb.com	

www.abb.com/mediumvoltage

The data and illustrations are not binding. We reserve the right to modify the contents of this document following technical developments.

© Copyright 2022 ABB. All rights reserved.