

Effective: September 2002
NEW INFORMATION

Type CVX and CVX-1 Synchro-Verifier Relays (for Class 1E Application)



Before putting relays into service, remove all blocking inserted for the purpose of securing the parts during shipment. Make sure that all moving parts operate freely. Inspect the contacts to see that they are clean and can close properly. Operate the relay to check the settings and electrical connections.

CONTENTS

This instruction leaflet applies to the following types of relays:

- CVX Synchro-Verifier Relay
- CVX-1 Syncho-Verifier Relay with line and bus voltage sensing relays (V1 & V2)

1.0 APPLICATION

These relays have been specially designed and tested to establish their suitability for Class 1E application in accordance with the ABB program for Class 1E Qualification Testing as detailed in the ABB bulletin STR-1.

“Class 1E” is the safety classification of the electric equipment and systems in nuclear power generating stations that are essential to emergency shutdown of the reactor, containment isolation, cooling of the reac-

tor, and heat removal from the containment and reactor, or otherwise are essential in preventing significant release of radioactive material to the environment.

The synchro-verifier is used to verify the condition of synchronism existing between two system voltages. The contacts will close when these voltages are within set limits.

LIMITATIONS:

- Relays should be set at 40° or higher.

- Time dial should be set at 1 or higher.

The synchro-verifier is not an automatic synchronizer and should not be used as such. Automatic synchronizers are available which permit closing ahead of synchronism at an angle of phase advance proportional to the beat frequencies and determined by the speed of operation of the circuit breaker so that the two systems are connected right on synchronism.

A common application of the synchro-verifier is in conjunction with automatic reclosing equipment or loop systems fed by generating stations at two or more points. When a line section trips out, the synchro-verifier is used at one terminal to check synchronism after the remote terminal is reclosed. If the two systems are in synchronism, the synchro-verifier permits the automatic reclosing equipment to reclose the breaker.

Some provision, such as a reclosing relay, must be used to control closing through the CVX(-1) contacts

All possible contingencies which may arise during installation, operation or maintenance, and all details and variations of this equipment do not purport to be covered by these instructions. If further information is desired by purchaser regarding this particular installation, operation or maintenance of this equipment, the local ABB representative should be contacted.

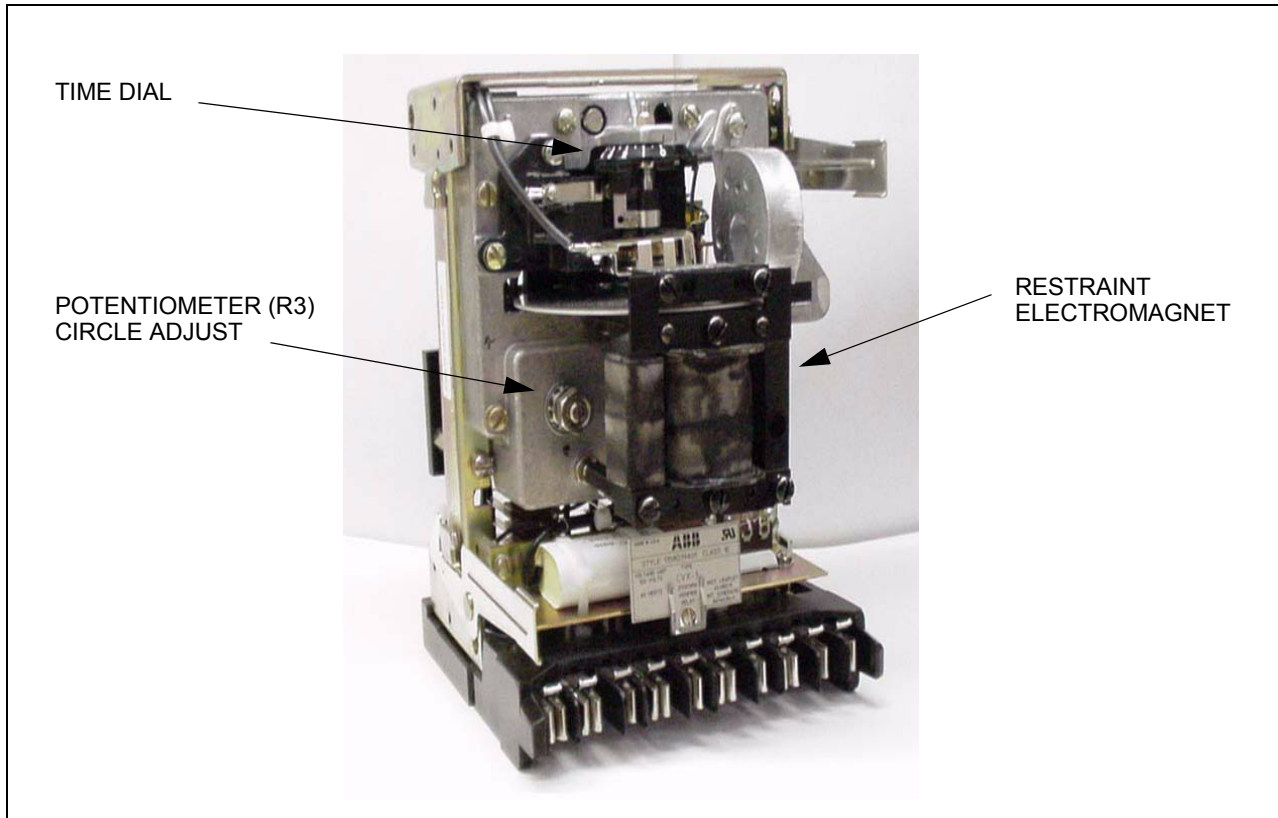

Figure 1. CVX-1 Relay Front View, Out of Case

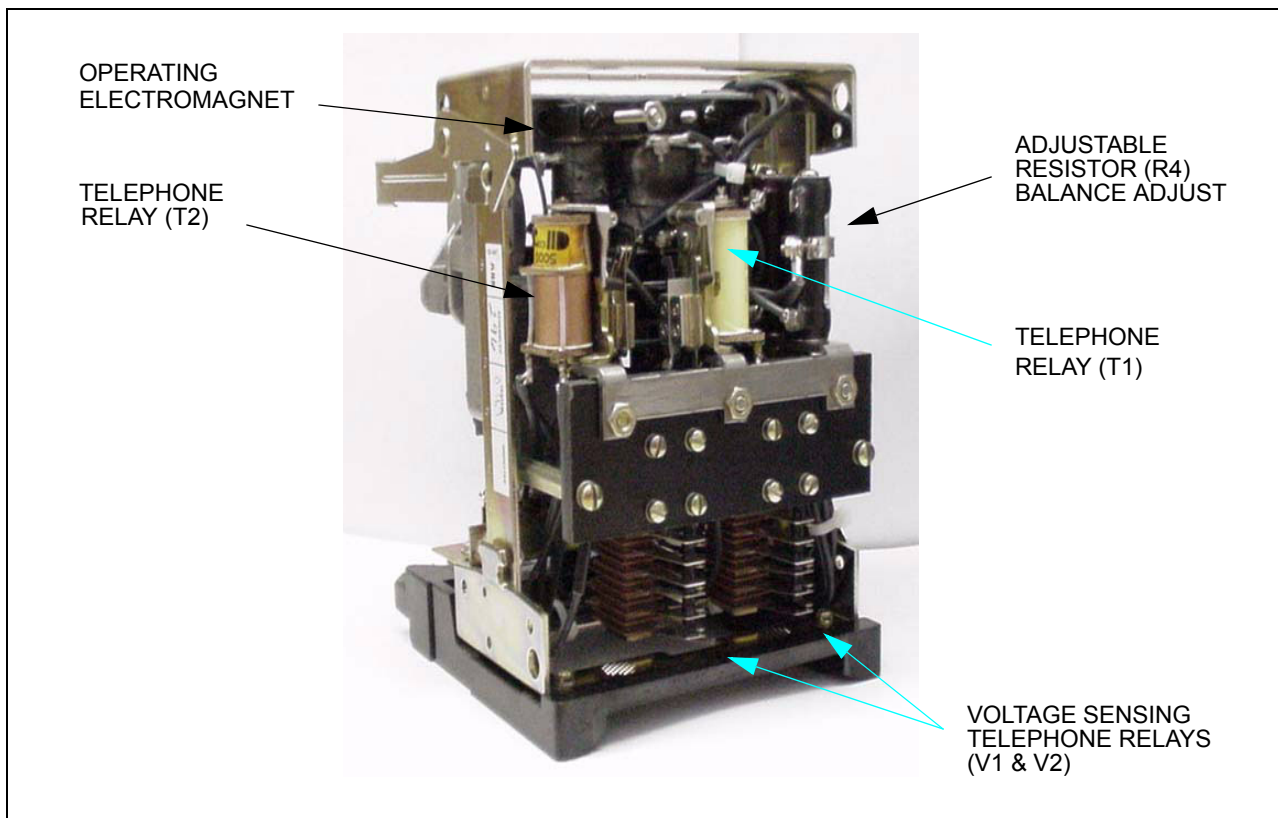

Figure 2. CVX-1 Relay Rear View, Out of Case.

to avoid the possibility of pumping when closing into a fault.

2.0 CONSTRUCTION AND OPERATION

The type CVX relay consists of an operating element (rear) and a restraining element (front) mounted on a common disc, a circle adjust potentiometer (R3), and a balance adjust resistor (R4). The relay also has telephone relays (T1 & T2) in the time delay circuit to override any possible contact chatter during a seismic event. See Figures 1 and 2.

The CVX-1 Relay in addition to the components noted above, has two telephone type ac voltage sensing relays (V1 & V2). See Figures 1 and 2.

2.1 OPERATING ELEMENT

The operating unit consists of an "E" type laminated electromagnet with two main coils on the center leg, a lag coil on the left leg, and a lag coil on the right leg. A resistor is connected across the shading coil.

When the relay is energized with two voltages, a flux is produced that is proportional to the sum of the applied voltages. This flux divides and returns through the outer legs of the electromagnet. The lag coil on the left leg causes the flux in that leg to lag the main pole flux. The out of phase fluxes thus produced in the disc gap causes a contact closing torque. The resistor connected across the lag coil of the electromagnet provides adjustment for different operating circles of the relay.

2.2 RESTRAINING ELEMENT

The restraining element consists of an "E" type laminated electromagnet with two main coils on its center leg and a lag coil on its left leg. A flux proportional to the difference of the applied voltages to the relay is produced. This flux divides and returns through the outer legs of the electromagnet. The lag coil causes the flux through the leg to lag the main pole flux. The out-of-phase fluxes thus produced in the disc gap causes a contact opening torque.

2.3 TIME DELAY CIRCUIT

The time delay circuit consists of two dc telephone type relays. This intentional time delay circuit applies to the CVX(-1) contact opening only, and is designed

to override any possible contact chatter during a seismic event.

2.4 AC TELEPHONE RELAYS (V1 & V2), CVX-1 ONLY

The telephone operating relay units are fast operating types energized by the application of an ac voltage. In these relays, an electromagnet energized by ac voltage, attracts a right angle armature which operates a set of contacts.

2.5 CVX OPERATION WITH EXTERNAL VOLTAGE RELAYS

The connections shown in Figure 6 using external type SG voltages relays will provide the following operation:

1. Close the breaker when the bus is live and the line is dead, through the 59B make contact and 27L break contact
2. Close the breaker when the line is live and the bus is dead, through the 59L make contact and 27B break contact.
3. Close the breaker when the line and bus are both live and when their respective voltages are approximately normal, equal in phase, and of the same frequency, through the CVX contact.

It is recommended that the number of reclosures be limited by using either a single or a multi-shot reclosing relay in conjunction with the CVX and SG relays.

2.6 CVX-1 OPERATION

In the CVX-1, the internal V1 and V2 perform the functions of external 59B and 27L relays respectively.

The connections shown in Figure 7 using the type CVX-1 relay will provide the following operation:

1. Close the breaker when the bus is live and the line is dead, through the V1 make contact and V2 break contact.
2. Close the breaker when the line is alive and the bus is dead, through the V2 make contact and V1 break contact.
3. Close the breaker when the line and bus are both live and their respective voltages are

approximately normal, equal, in phase, and of the same frequency through the CVX -1 contact.

It is recommended that the number of reclosures be limited by using either a single or a multi-shot reclosing relay in conjunction with the CVX1 relay.

3.0 CHARACTERISTICS

The type CVX and CVX-1 relays can be adjusted for operating circles from 40° to 60° as shown in Figure 8. The relay is typically calibrated for the 40° circle as shipped from the factory. These circles apply when one side has rated voltage. The relay operates if the other voltages falls within the appropriate circle.

The operating time of the relay is shown in Figure 9. These time curves are obtained from the #11 time dial setting when the applied voltages are equal to rated voltage, in phase and of the same frequency. Shorter operating times can be obtained at different time dial settings as shown in Figure 10.

Figure 11 shows the maximum slip frequency for which operation of the CVX element can occur. The maximum slip frequency is a function of the circle and time dial settings. This characteristic is of interest in estimating the worst case angular difference at the instant of breaker closure, for cases where the two systems are slipping slowly.

Figure 12 shows typical CVX reset times for 20°, 40° and 60° circle settings. **Note: Class 1E Relays should be set at 40° or higher.**

3.1 BURDEN

The burden imposed on each potential source by the CVX relay, with rated voltage applied to both circuits of the relay is as follows:

	60 Hertz	50 Hertz
Volt Amperes	15.4	23.3
Power factor	0.422	0.309
Watts	6.5	7.2

The burden of the CVX relay with rated voltage

applied to one circuit is as follows:

	60 Hertz	50 Hertz
Volt Amperes	15.4	23.3
Power factor	0.422	0.309
Watts	6.5	7.2

For the CVX-1 relay, additional burden of each telephone relay at 120 Volts is as follows:

Volt Amperes	10.62
Power Factor	0.64

4.0 RELAY SETTINGS

As shipped from the factory the relays are calibrated for a 40 degree circle. Other operating circles from 40° to 60° can be obtained by adjusting the left hand potentiometer (front view) in the relay. The procedure is described under Circles Other than 40 Degrees, in Section 7.7.

Set the time dial so that the relay will not operate when the systems are swinging too fast. The #11 time dial is recommended when the 60° circle setting is used. A setting of #4 time dial or higher is recommended with the 40° circle. If a longer delay is desired, a higher time dial setting may be used.

To evaluate the effect of time dial and circle settings on the worst-case phase-angle difference between the two systems at the instant of breaker closure, refer to Figure 9. For example, assume a 40° circle and #4 time dial setting. Also assume that the systems are slipping at a frequency of 0.048 hertz, Figure 11 shows the maximum slip for which the relay will operate. This means that the relay contacts closed just as the one voltage vector moves out of the circle.

This would mean that the system would be 40° out-of-phase at the instant that the breaker close circuit is energized. The phase angle at the instant of breaker closure is:

$$\phi = 40^\circ + 0.048 \times 360T_B = 40^\circ + 17.3T_B$$

where T_B = breaker closing time in seconds.

Let $T_B = 0.5$ Seconds

Then $40^\circ + 17.3 \times 0.5 = 48.6^\circ$

5.0 INSTALLATION

The relays should be mounted on switchboard panels or their equivalent in a location free from dirt, moisture, excessive vibration, and heat. Mount the relay vertically by means of the four mounting holes on the flanges for the semi-flush type FT case. The mounting screws may be utilized for grounding the relay. External toothed washers are provided for use in the locations shown on the outline and drilling plan to facilitate making a good electrical connection between the relay case, its mounting screws and the relay panel. Ground Wires should be affixed to the mounting screws as required for poorly grounded or insulating panels. Other electrical connections may be made directly to the terminals by means of screws for steel panel mounting.

For detail information on the FT case refer to Instruction leaflet 41-076 for semi-flush mounting.

6.0 ADJUSTMENTS AND MAINTENANCE

NOTE: The proper adjustments to insure correct operation of this relay have been made at the factory. Upon receipt of the relay, no customer adjustments, other than those covered under "Settings" should be required.

6.1 ACCEPTANCE CHECK

The following check is recommended to insure that the relay is in proper working order:

6.1.1 Disk Unit Contacts (Time Dial)

The index mark on the movement frame will coincide with the "0" mark on the time dial when the stationary contact has been moved through approximately one-half of its normal deflection. Therefore, with the stationary contact resting against the backstop, the index mark is offset to the right of the "0" mark by approximately 0.020". The placement of the various time dial positions in line with the index mark will give operating times as shown on the time curve.

6.1.2 Operating Circle

Connect the CVX relay per the test diagram, Figure 15. CVX-1 relays should be connected in a similar manner to correspond with the wiring of the particular style CVX-1 using Figure 16. The contacts should just close under the following condition:

When V_1 and V_2 are equal to rated voltage and their phase difference is between 38° and 42° (either leading or lagging), verify that the contacts should just open within the make angle plus approximately 4° .

6.1.3 Time Curve

With the time dial set at position 11, the contact should close in 6 ± 1 seconds when V_1 and V_2 , equal to rated voltage at zero phase angle, are applied.

6.1.4 Time Delay Circuit (T1, T2)

With test connections made according to Figures 15 and 16, open the D.P.S.T. switch. The timer start should be set on contacts (make) and the timer stop should be on volts (fall). The drop out time of T1 & T2 should be between 300 to 450 msec.

6.1.5 Telephone Relays (V1 & V2), CVX-1 Only

Apply ac voltage to each telephone relay circuit. The telephone relay should pickup when 95 volts ac is applied.

6.2 ROUTINE MAINTENANCE

All relays should be inspected periodically and the time of operation should be checked at least once every two years or at such other time intervals as may be dictated by experience to be suitable to the particular application.

All contacts should be periodically cleaned. A contact burnisher Style #182A836H01 is recommended for this purpose. The use of abrasive materials for cleaning contacts is not recommended, because of the danger of embedding small particles in the face of the soft silver contact and thus impairing the contact.

7.0 CALIBRATION

Use the following procedure for calibrating the relay if the relay has been taken apart, received repairs, or

the adjustments have been disturbed. This procedure should not be used until it is apparent that the relay is not in the proper working order (See Acceptance Check).

7.1 CONTACTS

For Disc Unit Contacts see section 6.1.1

7.2 PRELIMINARY ADJUSTMENTS

Remove the permanent magnet from the relay and set the time dial on the #11 position. Next unwind the spring for zero tension on the #11 position. This can best be noticed by unwinding the spring until the contact will not move when the time dial is moved a small distance beyond the #11 position.

The spring convolutions may touch during this operation and the outer convolutions may hit other surfaces of the relay. This interference should be disregarded because its effect on the final calibration will be negligible. The reason for unwinding the spring is that the amount of tension on the reset spring affects the diameter of the circle. Hence the spring tension has to be removed initially so that only the left hand potentiometer (R3) will affect the operating circle.

7.3 SPURIOUS TORQUE ADJUSTMENTS

- a) With the relay set as per the preliminary adjustments, open both lag coil circuits of the rear electromagnet. This can be done by opening the screw connection on both the lag coils of the rear electromagnet.
- b) Connect the relay to test circuit of Figure 15 for CVX, or Figure 16 for CVX-1, and then apply rated voltage at zero phase angle on both circuits. All voltage settings are to be within 1/4 Volts.

7.4 CENTERING CIRCLE

- a) De-energize the relay and close the left lag coil circuit front view of the rear electromagnet and set the left hand potentiometer (R3) at approximately one-third of its resistance.
- b) Adjust the phase shifter on the lagging direction until the contacts just close with V_1 and V_2 equal to rated voltage. Note the angle at which the contacts just close.

- c) Adjust the phase shifter in the leading direction until the contacts just close with V_1 and V_2 equal to rated voltage. If the latter angle is not within ± 1 degree of the former angle, adjust R4, the top right hand resistor (rear view) until the two angles are within ± 1 degree of each other.

7.5 SPRING ADJUSTMENT

- a) Adjust R3, the left potentiometer (front view) such that the moving contact just leaves and returns to the backstop of the time dial at the #11 position between 30° and 31° for CVX and between 35° and 36° for CVX-1 with rated voltage on both sides (leading or lagging: increasing the resistor decreases the angle).
- b) Change the angle to 40° and adjust the reset spring until the contacts just make.
- c) Rotate the phase shifter to move V_2 through zero phase angle where the contacts just make. The contacts should just close at an angle of $40^\circ \pm 2^\circ$ with V_1 and V_2 equal to rated voltage.
- d) With V_1 equal to rated voltage, the contacts should just close when V_2 is increased to $60V \pm 2.5V$ in phase with V_1 . If necessary, readjust spring slightly to obtain this condition. The relay is now calibrated for a 40° circle. Spring convolutions must not touch after this adjustment.
- e) Reconnect the right lag coil of the rear electromagnet and adjust R3, the left hand potentiometer (front view) to achieve the 40° degree circle (where the contacts just close at an angle of $40^\circ \pm 2^\circ$).

7.6 TIME CURVE

Install the permanent magnet on the relay. Adjust the permanent magnet keeper until the operating time of the relay from the #11 time dial position is ± 6 seconds with V_1 and V_2 equal to rated voltage at zero phase angle.

7.7 CIRCLES OTHER THAN 40 DEGREES

This adjustment should not be done until the above adjustments for a 40° circle has been completed.

If another circle other than 40° is desired, adjust R3, the left hand potentiometer (front view) to obtain the desired circle. For example, if a 50 degree circle is

desired, adjust R3 until the contacts just close with V_1 and V_2 equal to rated voltage at 50° phase angle. It may be necessary to readjust R4, the right hand resistor (rear view) to position the desired circle symmetrically about the zero degree line. See "Centering Circle" (section 6.4) for procedure. The time for the

operation will be as shown in the time curves of Figure 10.

8.0 RENEWAL PARTS

Repair work can be done most satisfactorily at the factory. However, interchangeable parts can be furnished to the customers who are equipped for doing repair work. When ordering parts, always give the complete nameplate data.

LIST OF FIGURES

Figure 1	CVX-1 Relay Front View, Out of Case	Pg.2
Figure 2	CVX-1 Relay Rear View, Out of Case	Pg.2
Figure 3	Internal Schematic Type CVX Synchro-Verifier Relay with Isolated Potential Circuits, in Type FT-21 Case - 9676A63	Pg.9
Figure 4	Internal Schematic Type CVX-1 Synchro-Verifier with HBDL/HLDB Outputs Isolated from CVX-1 Contact. Common Potential Circuits, in Type FT-21 Case - 9676A30	Pg.10
Figure 5	External Schematic of Type CVX Synchro-Verifier Relay, in type FT-21 Case - 9676A69	Pg.11
Figure 6	External Schematic of Type CVX Synchro-Verifier Relay, in type FT-21 Case, with External Voltage Relays - 9676A78	Pg.11
Figure 7	External Schematic of the Type CVX-1 Synchro-Verifier Relay, in Type FT-21 Case - 9676A70	Pg.12
Figure 8	Curve, Typical Voltage Angle characteristics - 184A997	Pg.12
Figure 9	Curve, Typical Time Phase Angle Curves - 184A998	Pg.13
Figure 10	Curve, Operating Time Variations - 184A999	Pg.14
Figure 11	Curve, Maximim Slip Frequency Cuves - 185A123	Pg.15
Figure 12	Curve, Typical Reset TImes - 619595	Pg.16
Figure 13	Curve, V_1 Voltage for Different Operating Circles - 471191	Pg.17
Figure 14	Curve, Operating Times from #11 Time Dial Setting - 471192	Pg.17
Figure 15	Test Diagram for CVX Relay - 1507B43	Pg.18
Figure 16	Test Diagram Type CVX-1 Relay - 1507B44	Pg.19
Figure 17	Outline and Drilling Plan for FT-21 Case - 3519A66	Pg.20

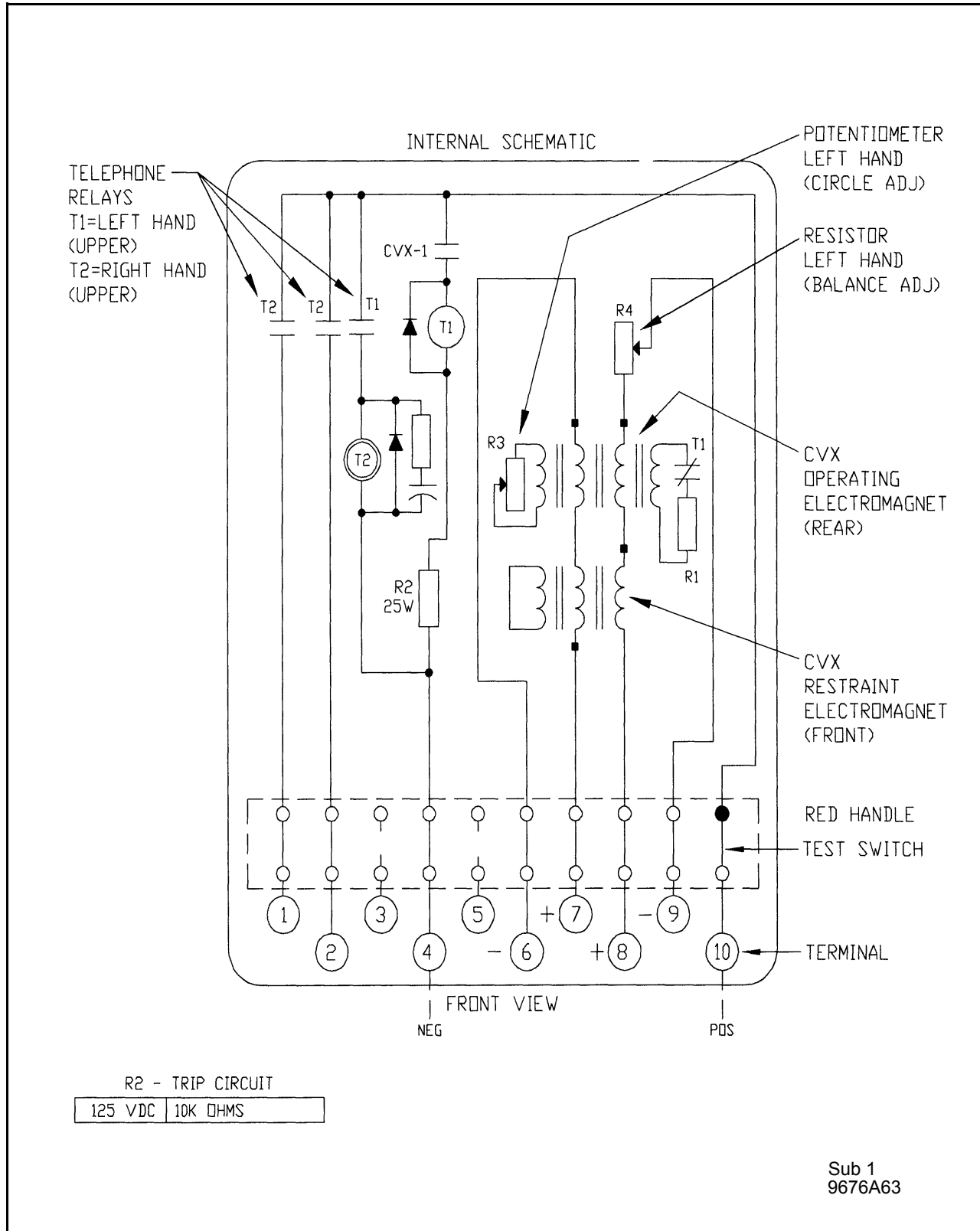

Figure 3. Internal Schematic CVX Synchro-Verifier Relay with Isolated Potential Circuits.

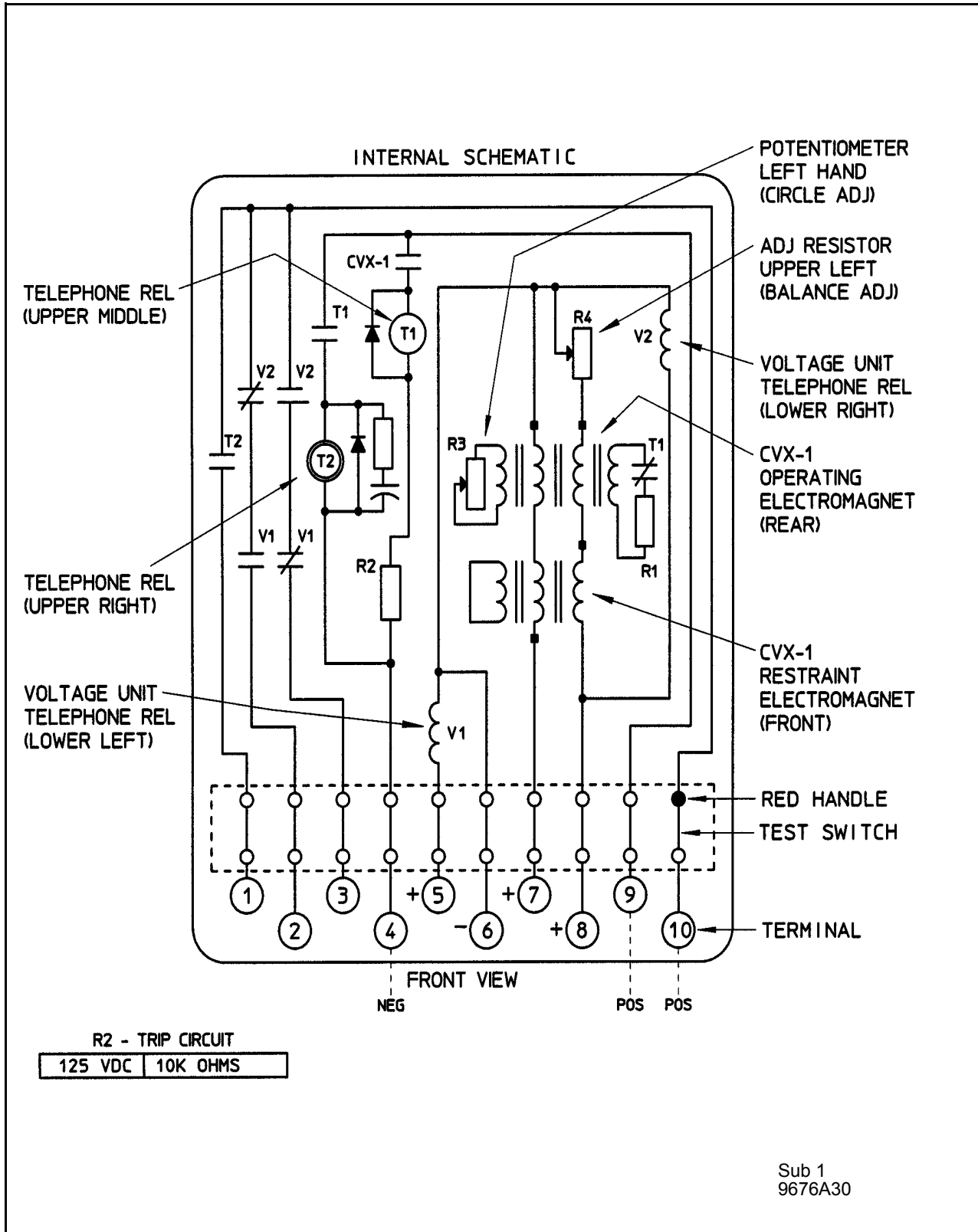

Figure 4. Internal Schematic Type CVX-1 Synchro-Verifier Relay in Type FT-21 Case with HBDL/HLDB Outputs Isolated from CVX-1 Contact, and with Common Potential Circuits.

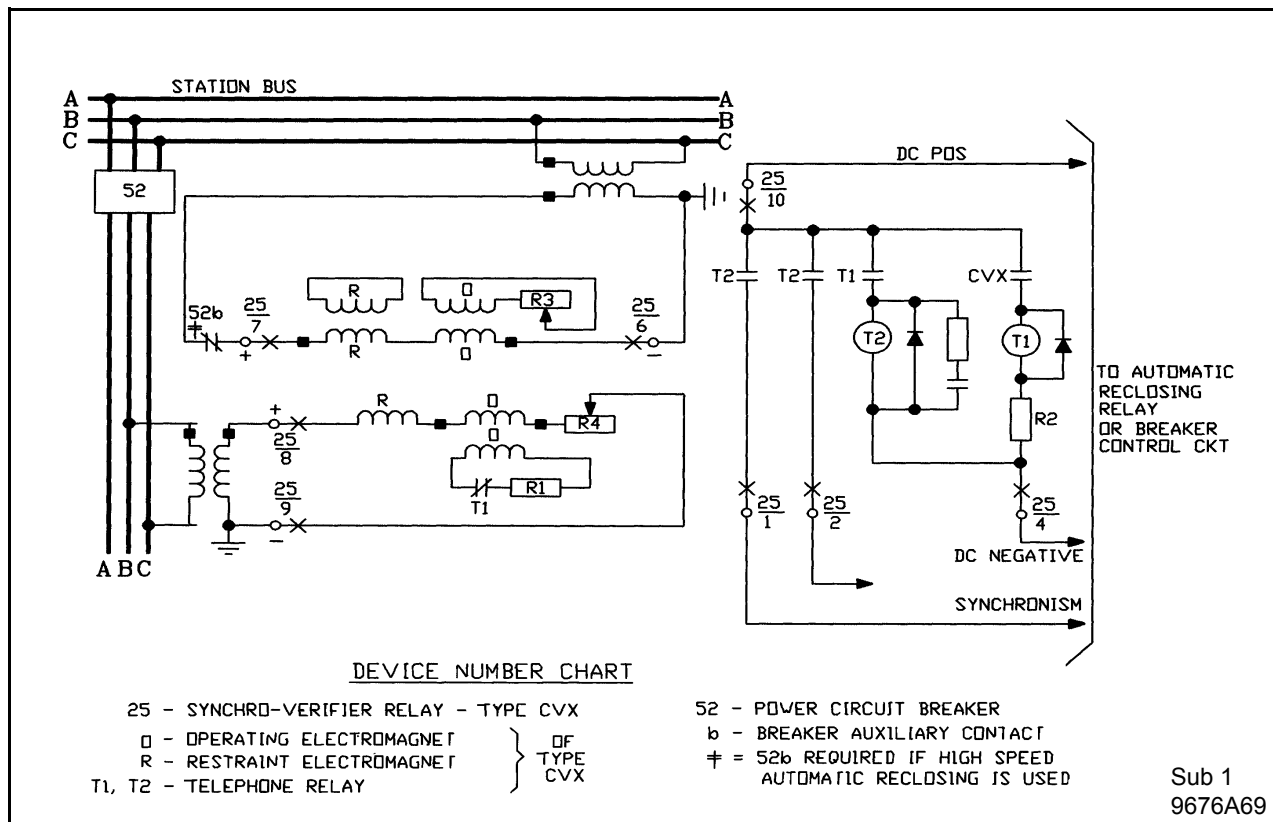

Figure 5. External Schematic of Type CVX Synchro-Verifier Relay with Isolated Potential Circuits.

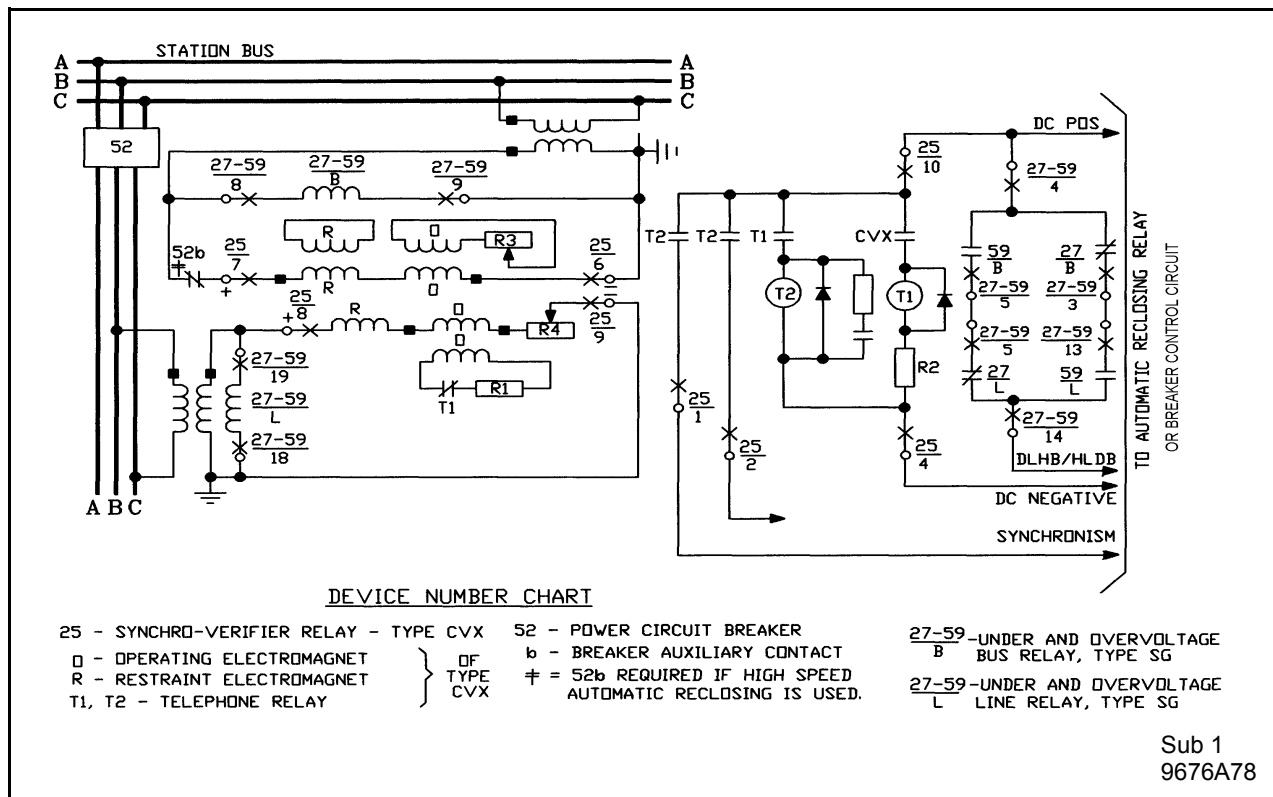

Figure 6. External Schematic of Type CVX Synchro-Verifier Relay with Isolated Potential Circuits and External Voltage Relays.

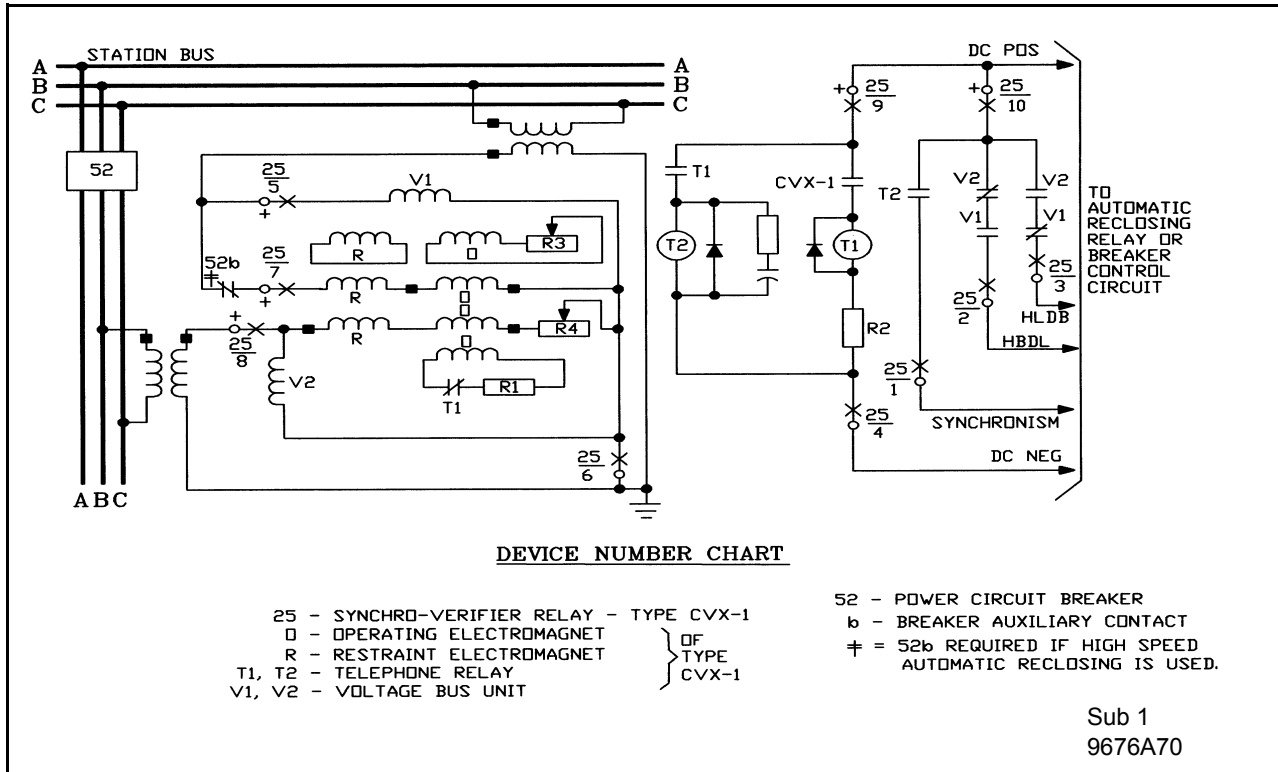

Figure 7. External Schematic of Type CVX-1 Synchro-Verifier with HBDL/HLDB Outputs Isolated from CVX-1 Contact, and with Common Potential Circuits.

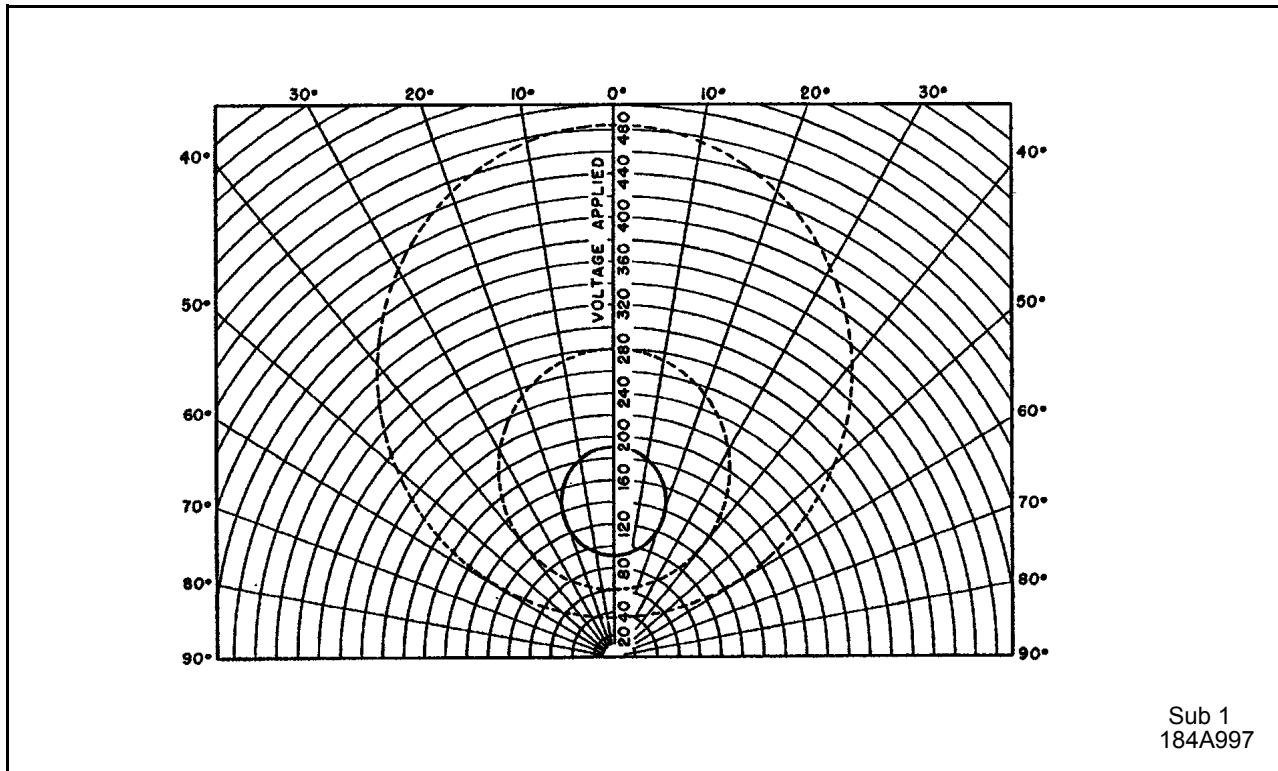
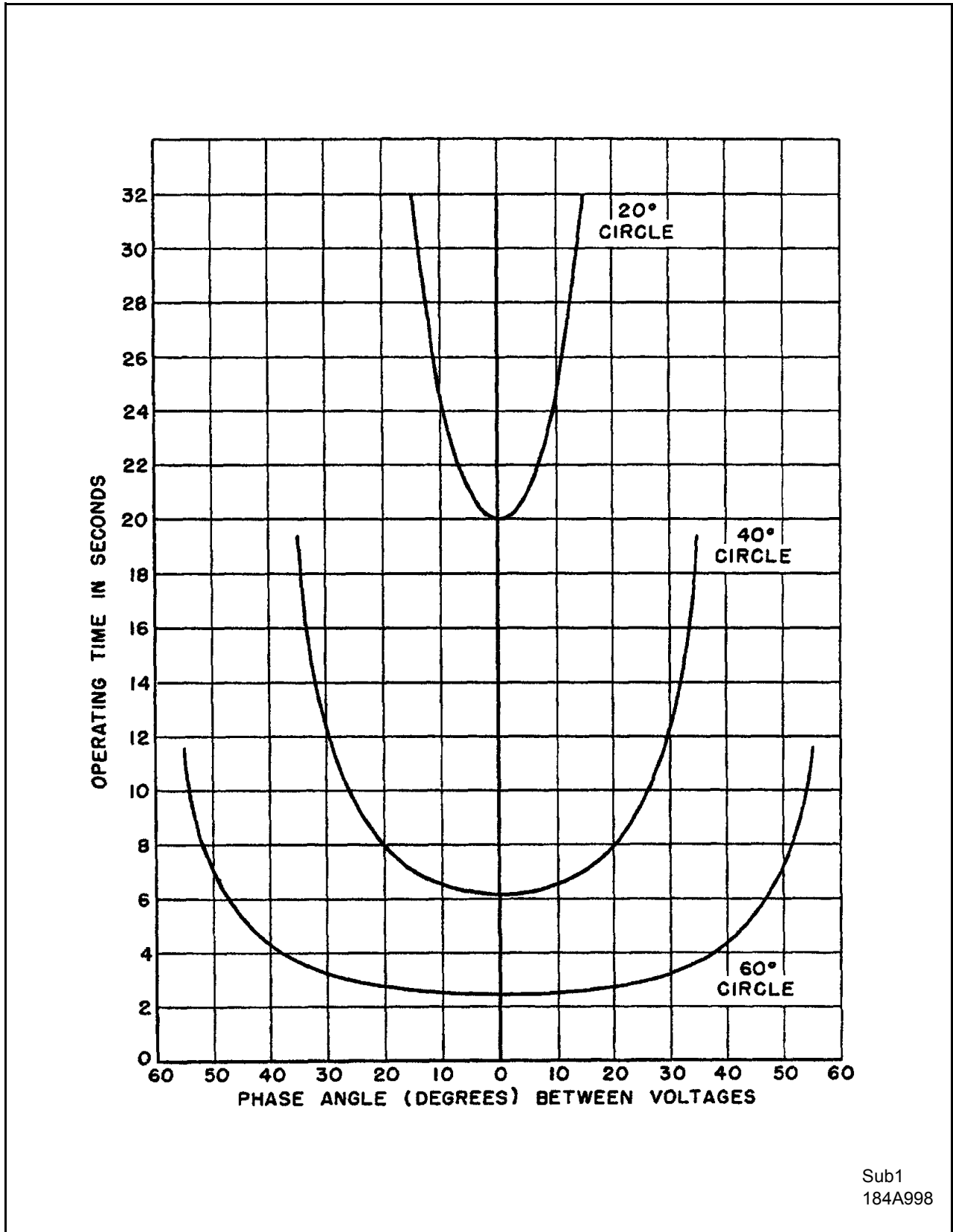

Figure 8. Typical Voltage-Angle Characteristic of CVX and CVX-1 for Various Closing Angle Settings, Rated Voltage on One Circuit.



Sub1
184A998

Figure 9. Typical Time Phase Angle Curves of CVX and CVX-1 Relays. Rated Voltage on Both Circuits. Number 11 Time Dial Setting.

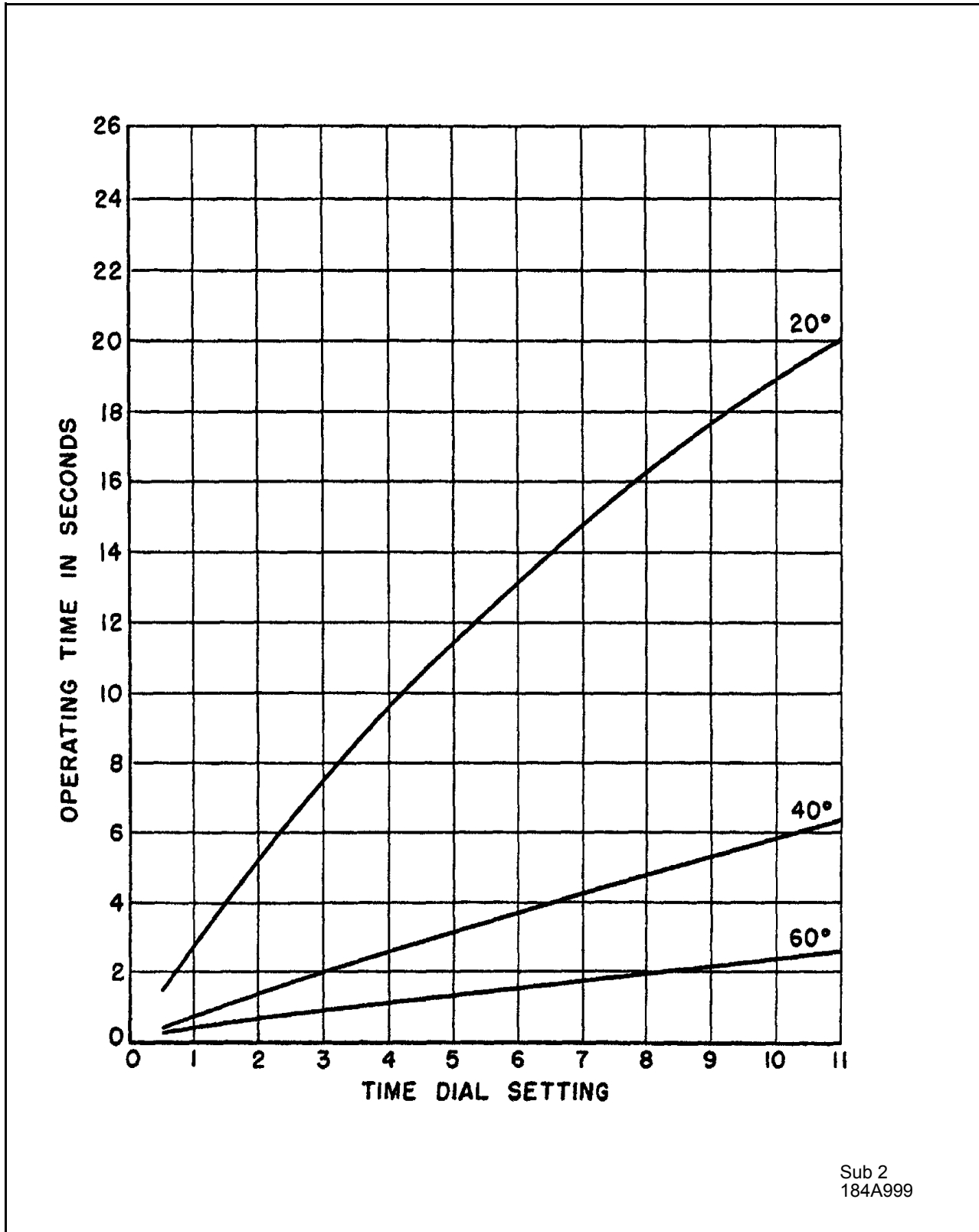
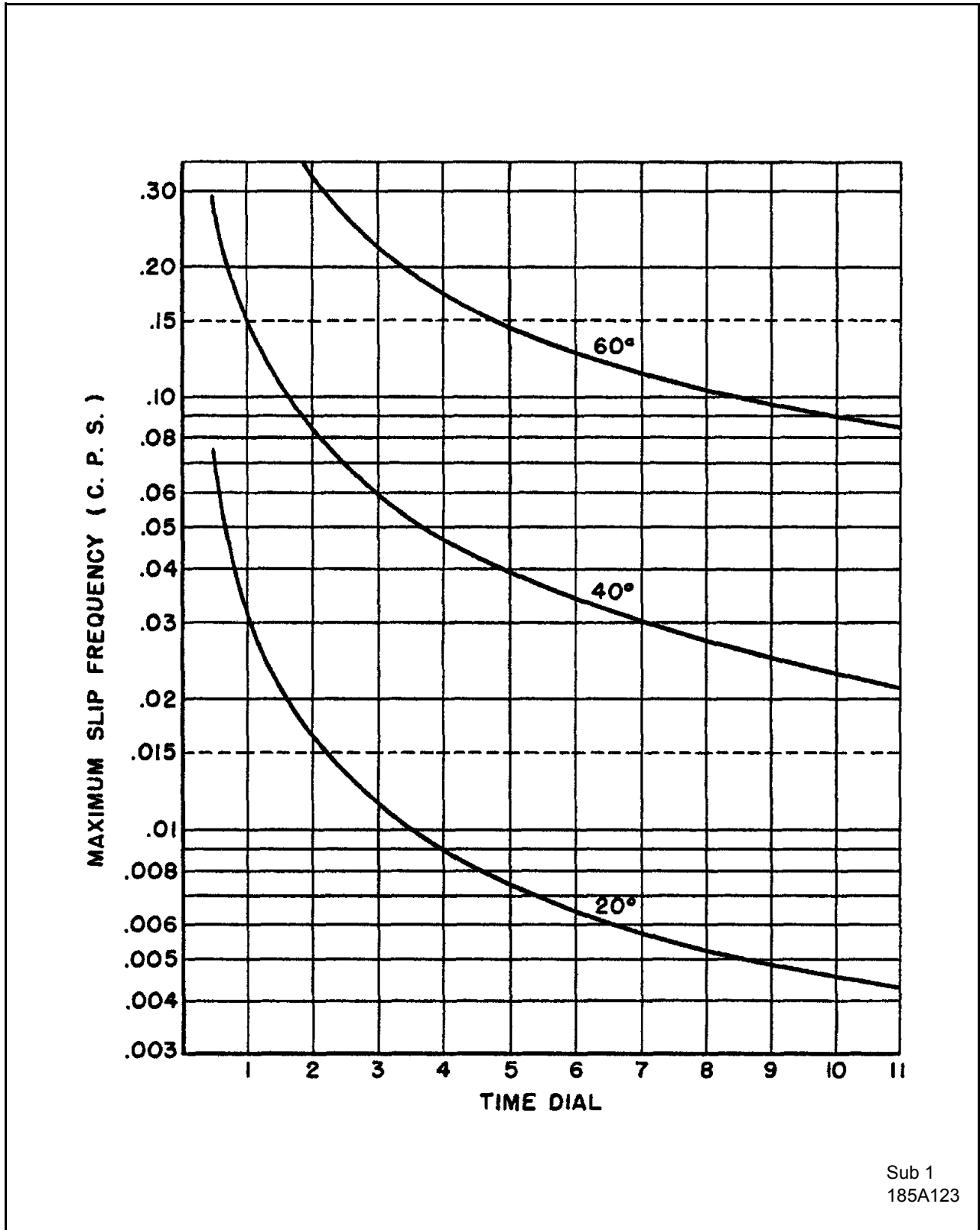

Figure 10. Operating Time Variations with Changes in Time Dial Settings. Rated In-Phase Voltage on Both Circuits, 20, 40, and 60 degree Circle.



Sub 1
185A123

Figure 11. Approximate Maximum Slip Frequency for which Operation Occurs. Rated Voltage Both Sides.

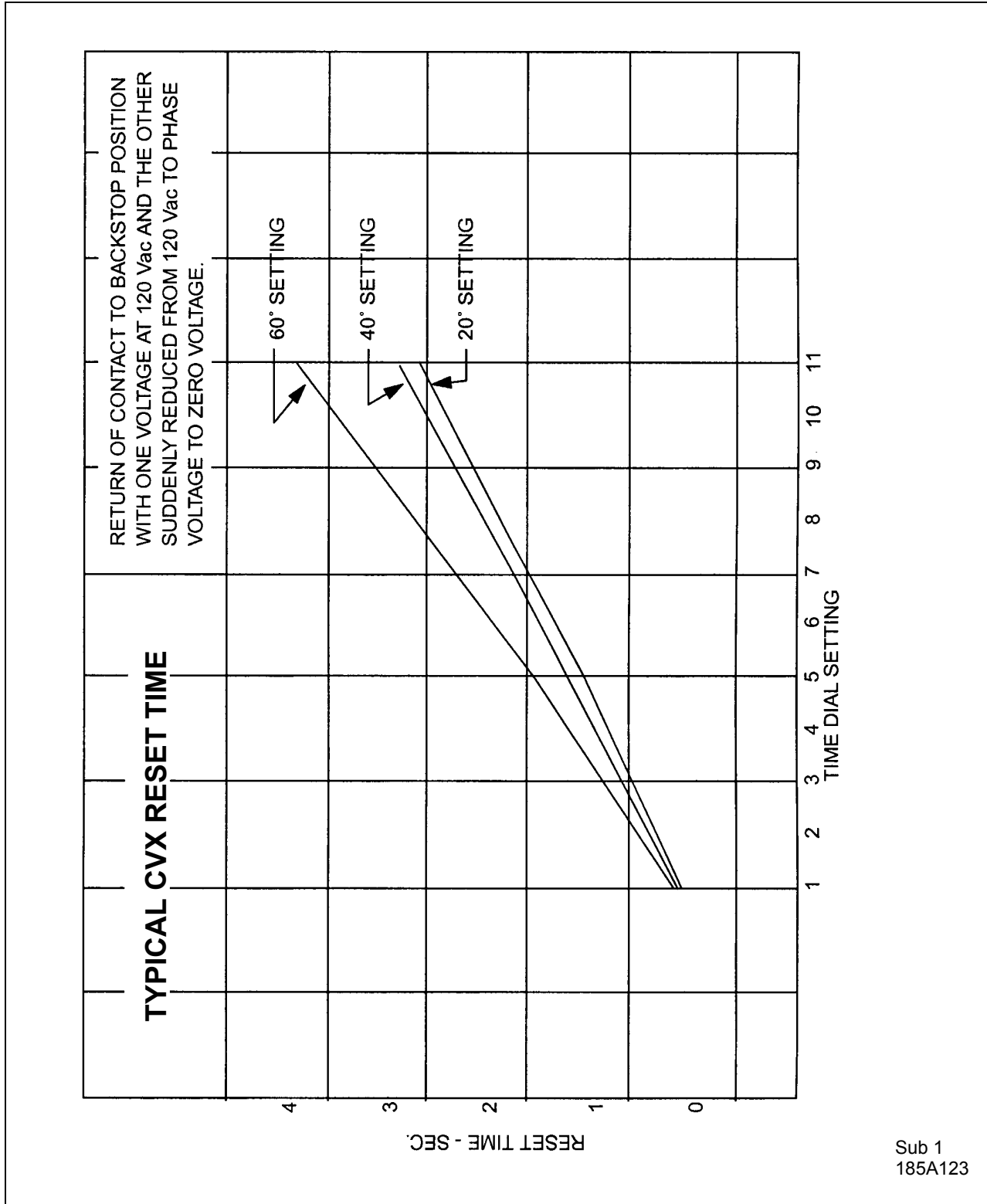
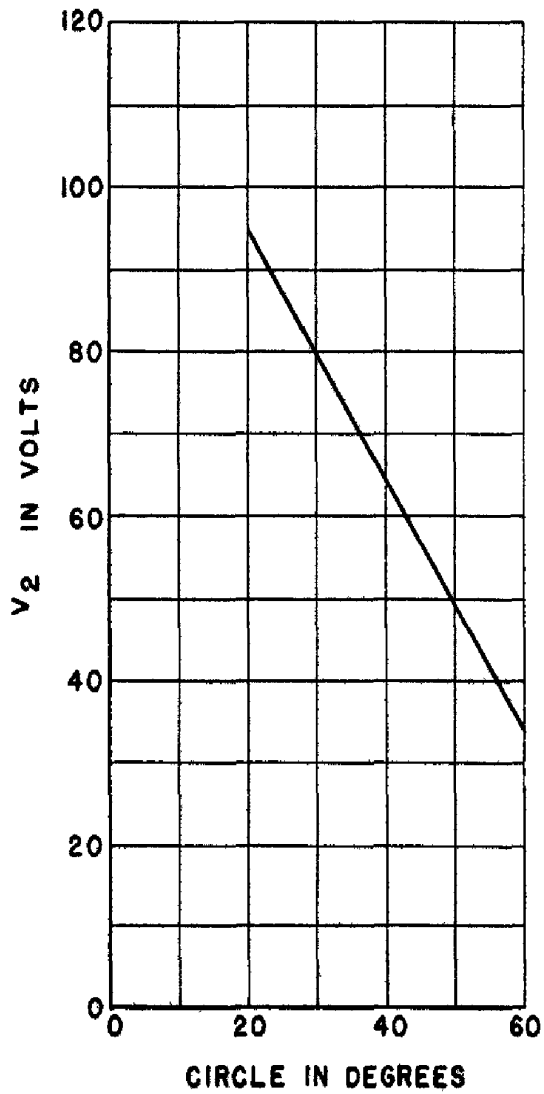
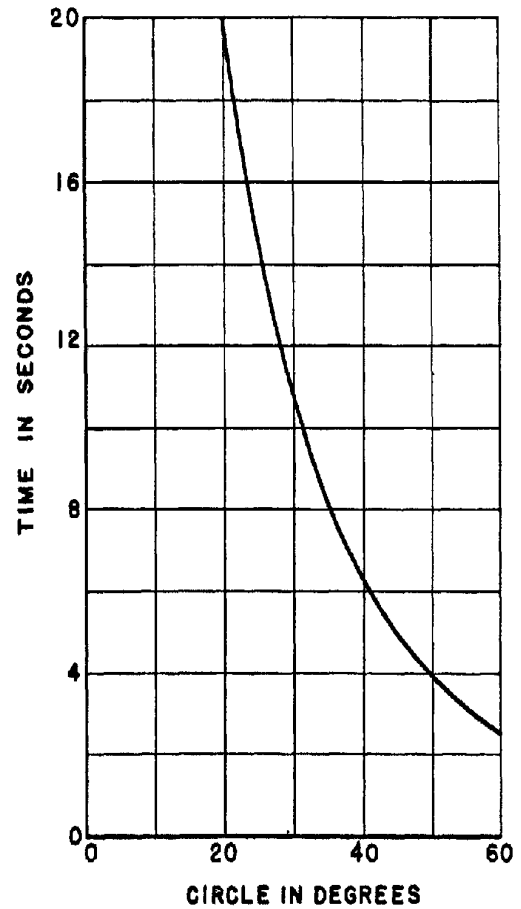

Figure 12. Typical CVX, CVX-1 Reset Times. Return of Contact to Backstop Position with one Voltage at Rated Voltage and the Other Suddenly Reduced from Rated in Phase to Zero Voltage.



Sub 1
471191



Sub 1
471192

Figure 13. V_1 Voltage for Different Operating Circles, V_2 is Equal to Rated Voltage at Zero Phase Angle.

Figure 14. Operating Times from the #11 Time Dial Position, set for Different Operating Circles. V_1 and V_2 are Equal to Rated Voltage at Zero Phase Angle.

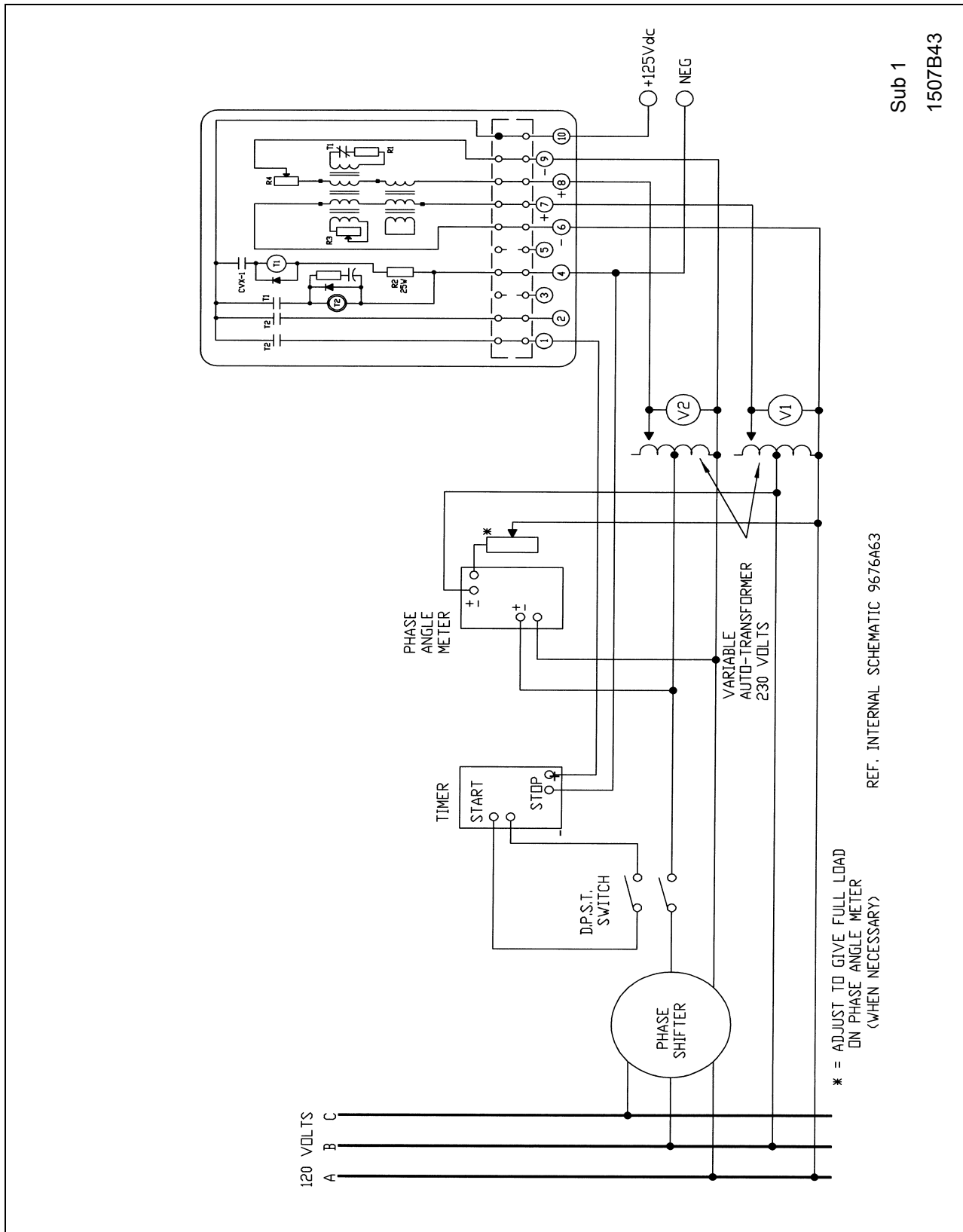
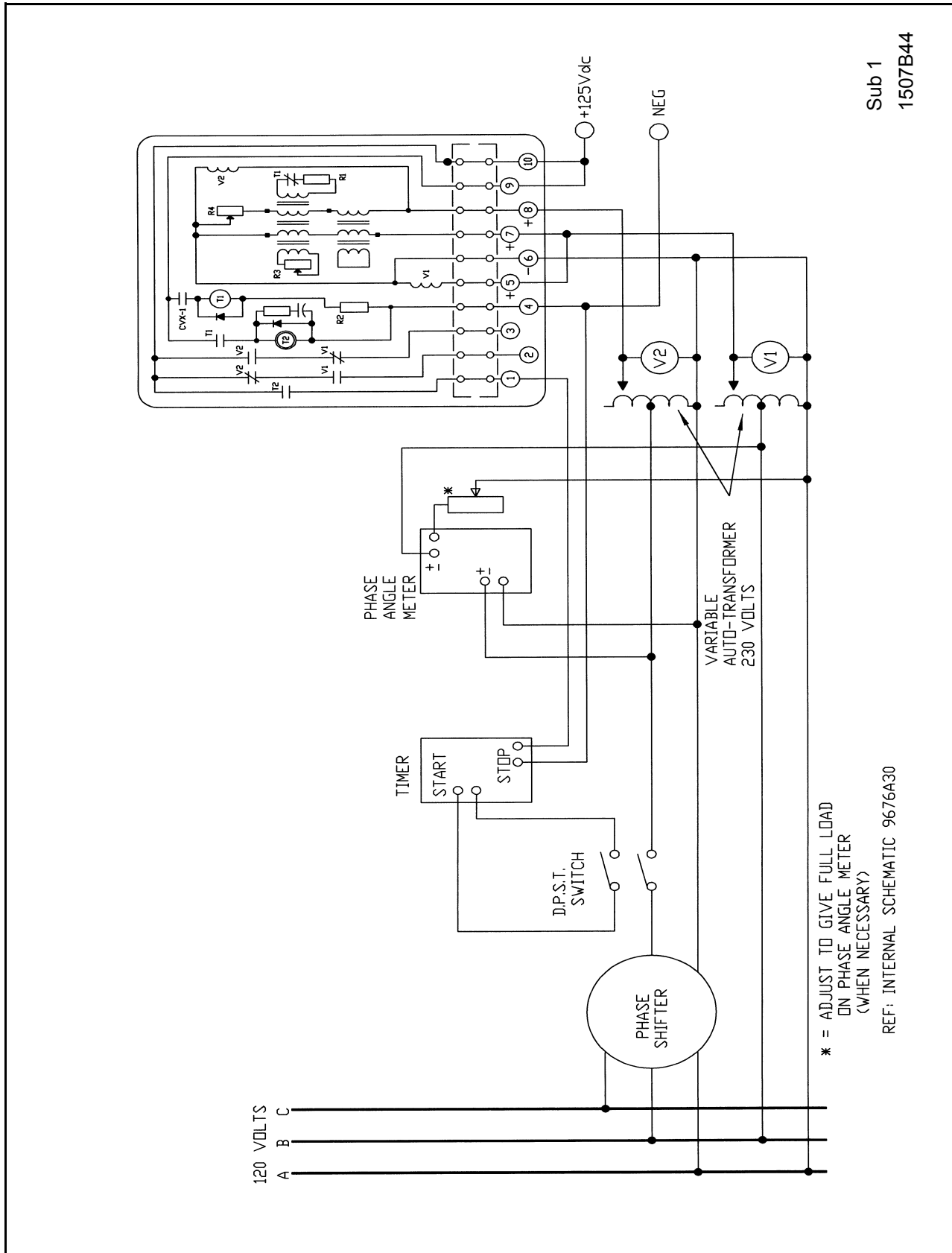

Figure 15. Test Diagram for CVX Synchro- Verifier Relay with Isolated Potential Circuits



Sub 1
1507B44

Figure 16. Test Diagram for Relay Type CVX-1 Synchro-Verifier with Common Potential Circuits.

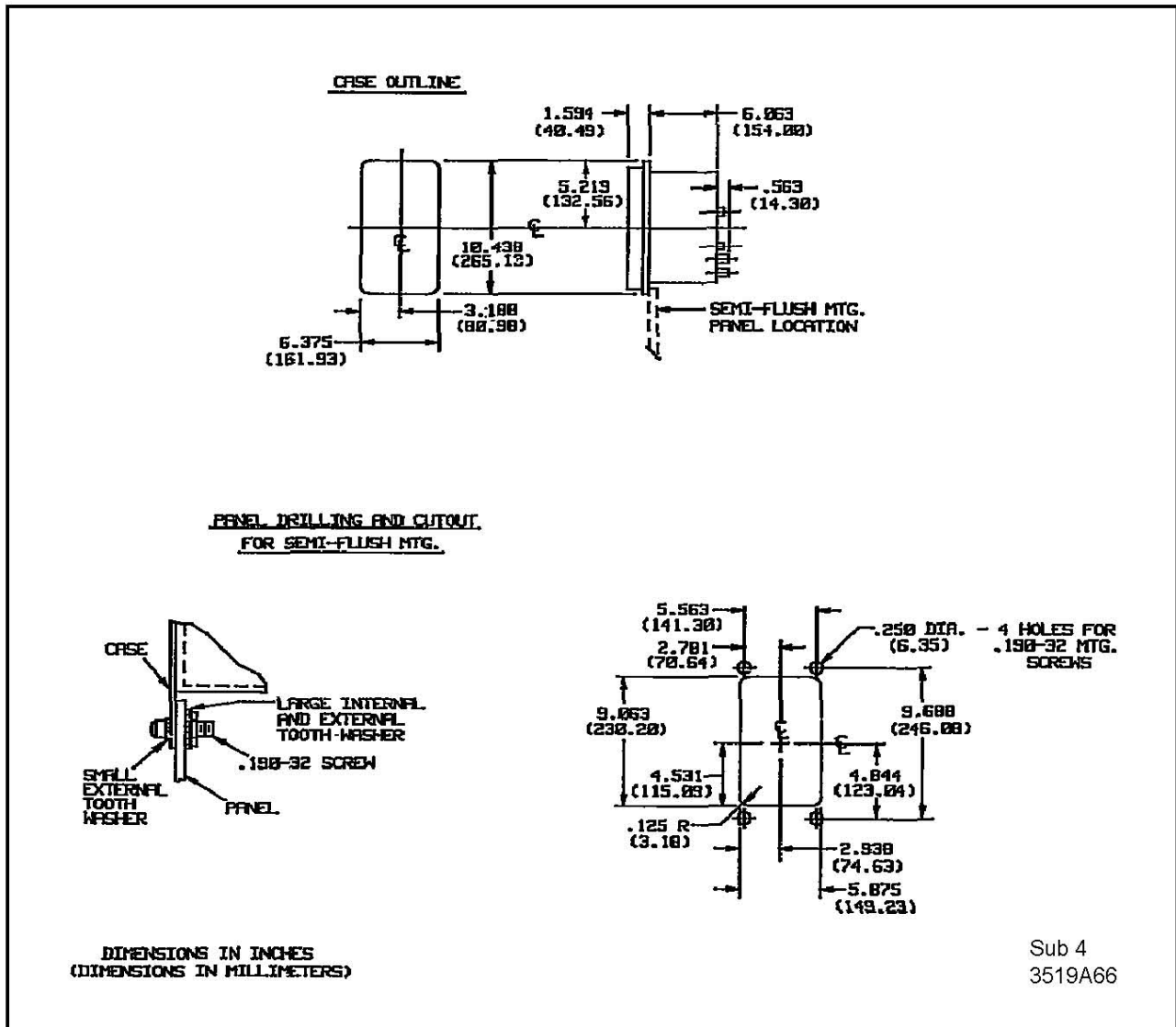

Figure 17. Outline and Drilling Plan for Type CVX and CVX-1 Relays in FT-21 Case



ABB Inc.

4300 Coral Ridge Drive
Coral Springs, Florida 33065

Telephone: +1 954-752-6700

Fax: +1 954-345-5329

www.abb.com/substation automation