



Driving value

Sophisticated ring-gear mill drives from ABB (Part 1)

MARCO RUFLI, MAARTEN VAN DE VIJFEIJKEN – The latest generation of ABB medium-voltage frequency converters provides excellent opportunities to improve the grinding process used in the minerals industry. Thanks to the development of several dedicated and advanced operational functions for the ring-gear grinding mills used in the industry, this generation of drives ensures smooth,

safe and reliable operation with minimum stress on the mechanical equipment, as well as the highest possible availability of the mill. Part one of this two-part series will explain the operational benefits of implementing these functions, while part two will focus on the practical experiences gained with this kind of sophisticated ring-gear mill drive system.



With gearbox



Without gearbox

2 A simplified overview of a dual-pinion high-speed mill drive and dual-pinion low-speed mill drive

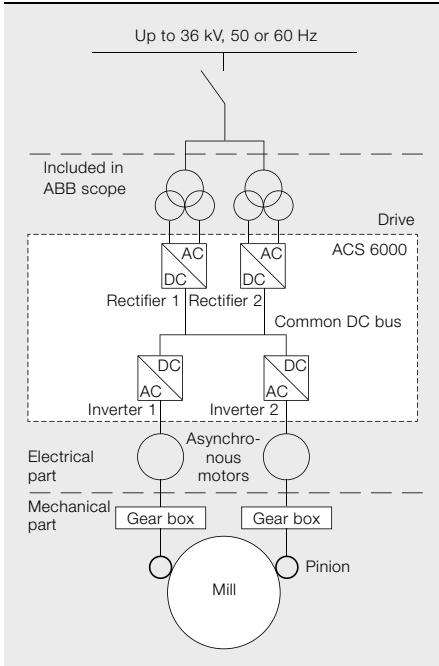

With gearbox

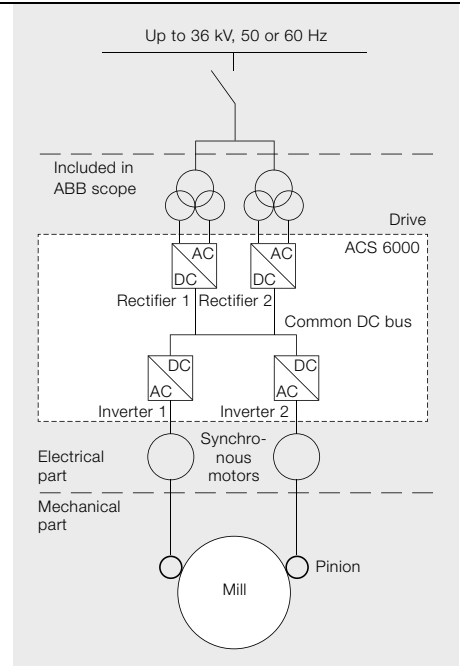

Without gearbox

The demands of grinding mills can be split into operational, maintenance and protection: For smooth and safe operation, it is important that critical situations are avoided as much as possible; maintenance functionality must be quick and easy to execute; and protection of the system is important under all operating conditions.

In ring-geared mill drives (RMDs) and especially dual-pinion systems → 1, the mechanical stress added by the motors can be significant. Therefore the control concept between the two motors must be fast and accurate to avoid any additional stress to the pinions and ring gear.

These demands can not only be reached but exceeded with ABB's latest generation of medium-voltage (MV) frequency-converter drives, which contain new and dedicated mill functions. The addition of an extra controller (ie, a mill controller) not only permits the inclusion of a lot of application related functionality and protection, but it also simplifies the interface between the mill drive system and the customer's distributed control system (DCS). The drives feature direct torque control (DTC) technology → 2, which is known as the most advanced control method for AC drives in which the motor

variables (torque and flux) are directly controlled by inverter switching. Operational- and maintenance-related functionality can only be added by using variable-speed drives and the accurate control that is part of the drive design. In addition, all inherent features of a frequency-converter drive benefit the system and provide greater flexibility in the control of the complete grinding process. These benefits include very accurate current and torque measurements, power-drop ride through and earth-fault and short-circuit protection.

On larger ring geared mills where the length of the pinion and ring-gear teeth is gradually increasing, the perfect alignment of the pinion and ring gear (and gearbox in some cases) is pivotal. However, experience has shown that it can be difficult to achieve and maintain perfect alignment; therefore, it is essential to

avoid rough starts and torque spikes, in particular in larger mills. During all operation conditions (ie, starting, normal grinding operation, stopping) a mechanically friendly system is required.

The electric drive system configuration discussed in this article consists of a converter transformer, an ABB ACS 6000 multidrive MV frequency converter and two ABB AMI630 four-pole squirrel-cage asynchronous motors. The following sections explain the drive system performance during start, operation and stop sequences and how the system helps to improve overall mill operation.

Mill starting and stopping

The mill start sequence is completely controlled by the electric drive system; the customer's DCS (or an operator-controlled local control panel close to the mill) only needs to send a simple start

command and the desired operation speed reference. To perform a smooth and safe start, the drive system first ramps up to the predefined starting speed (typically about 10 percent of nominal speed) where it is maintained and the torque and mill angle monitored. Normally the material in the mill cascades before the mill has turned 90 degrees. However, if the charge is locked or “frozen,” it will drop from the top of the mill after it has turned 180 degrees. This could severely damage the mill and its bearings, resulting in an extensive and unscheduled shutdown. This situation can be avoided with ABB’s sophisticated drive control technology which only releases the drive to follow the customer’s DCS speed reference if the mill controller measures cascading of the material by a decreasing torque before the critical angle is reached → 3. From then on the drive is under the customer’s control, which means it will accurately follow any speed change requested by the DCS.

During startup there is a potential risk of a dropping frozen charge, which can seriously damage the mill shell, bearings and other equipment. ABB’s mill controller completely eliminates this risk, and no further actions like creeping are required before giving a start command, even after a long downtime. If a frozen charge really does exist in the mill, the drive will trip and perform a coast stop before the critical angle is reached. In short, starting is extremely smooth for the mechanical components, such as the gearbox, pinion and ring gear as no huge torque spikes occur.

A section of the starting area shown in → 3 is magnified in → 4. The very first small torque peak (in maroon) demonstrates the breakaway torque after which the motor speed is ramped up slowly and gently while the torque increases with the mill rotating angle. At an angle of approximately 30 degrees (the first main torque peak is roughly 94 percent of rated torque, and the second and maximum torque peak is approximately 113 percent of rated torque), the material starts to cascade. Once the cascading charge has been detected, the mill is released to continue running at low speed until continuous cascade is reached, as illustrated by the constant torque measurements. At an angle of approximately 200 degrees the system is running sta-

3 A complete start/stop sequence

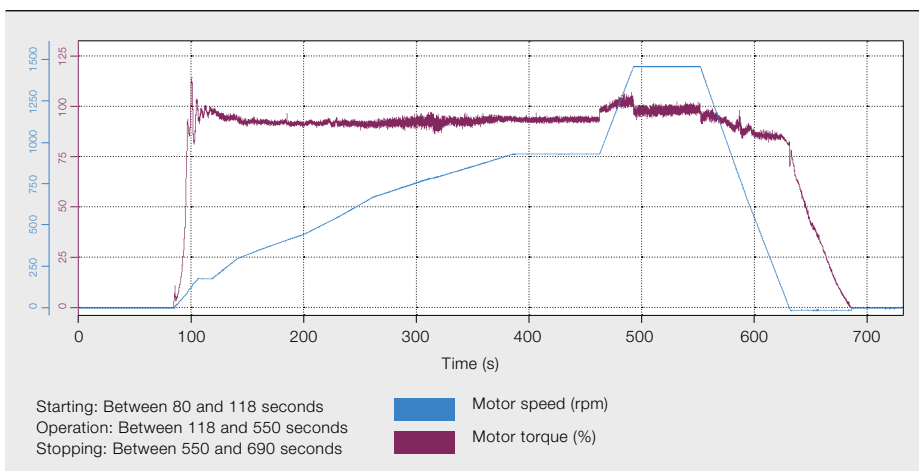

4 Start sequence with frozen charge protection

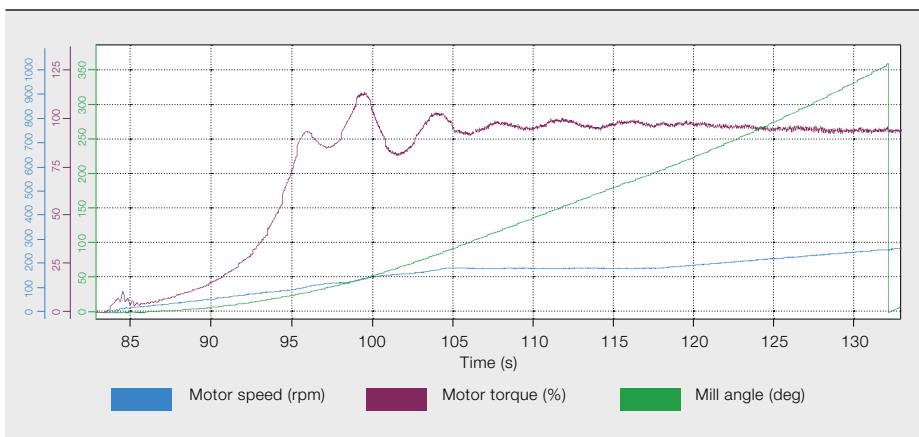

ble, finally enabling the mill controller to release the drive so that it can follow the DCS speed reference.

The maximum possible motor torque can be limited in the drive with separate starting levels (higher torque limitation, such as 130 percent of rated torque) and for normal operation after starting (lower torque limitation, such as 110 percent of rated torque).

As well as being mechanically friendly, the starting process barely affects the electrical supply network because, as the motor is decoupled from the network via the ACS 6000 converter, there are no high starting currents as is typical with direct-online motors. Therefore, the current drawn from the network during starting is (at the maximum peak of 113 percent rated torque) only about 12 percent of the rated current.

Operation area

Once the mill controller releases the drive, the speed can be adapted by the operator according to the process

In ring-gear mill drives (RMDs), the mechanical stress added by the motors can be significant, and the control concept between them must be fast and accurate.

5 Normal operation

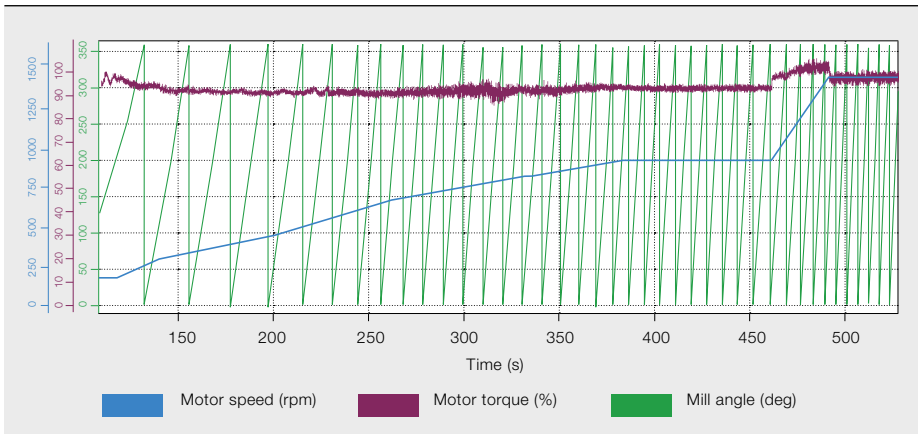

requirements. The electrical drive system can deliver constant torque over the entire speed range. It is also possible to run above nominal speed but with reduced torque (constant power operation area).

In → 5, the operator slowly ramps up to the reference speed. After remaining at two-thirds of the nominal speed for more than a minute, the mill is ramped up to a top speed of almost 1,500 rpm (motor rated speed). Though it jumps slightly during the ramp-up (the acceleration torque is about 7 percent of nominal torque), the torque remains fairly constant over the entire speed range.

6 A complete stop sequence

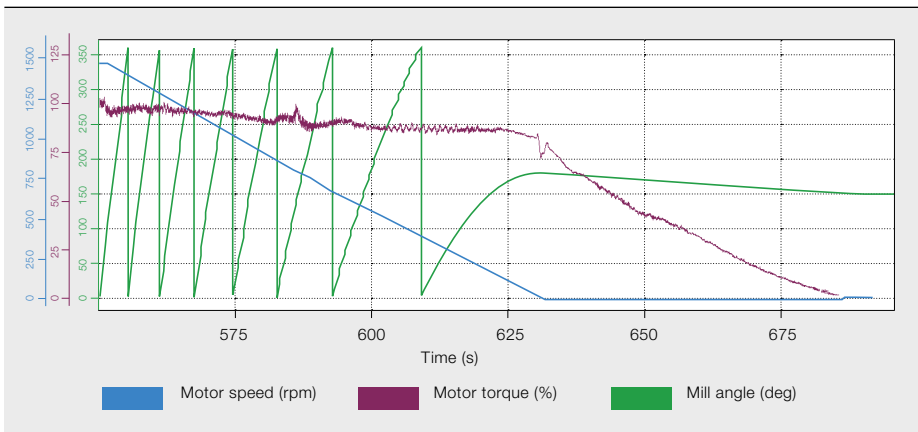

Stop sequence with controlled rollback

When a stop command has been issued by the DCS, the mill controller will assume full control of the stop sequence. To avoid the unnecessary and long backward and forward rocking of the mill caused by a coast stop, ABB has implemented a function called “controlled rollback,” which quickly brings the mill into a torque-free position in a controlled way.

7 A close-up view of controlled rollback

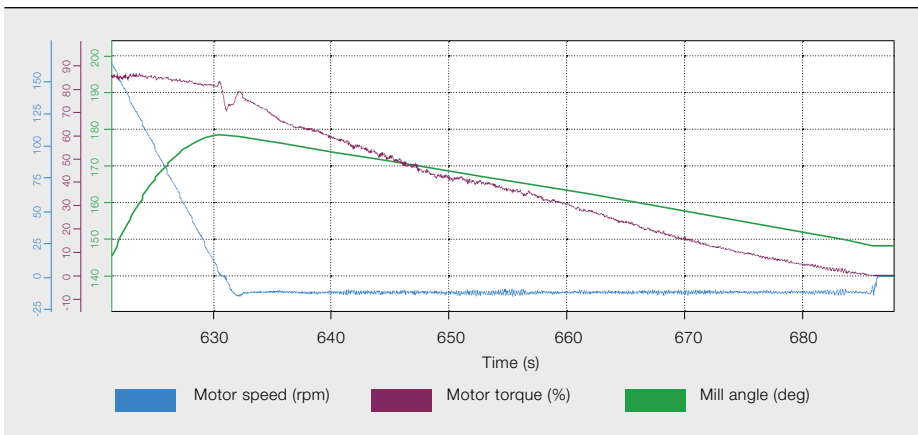

For fast, easy and safe maintenance of the mill, ABB has implemented dedicated maintenance functions in the mill controller.

It works by ramping the speed down to zero. When it reaches zero, the drive system then proceeds slowly in the reverse direction in order to roll back the mill until no torque remains in the system → 6. During this time the motor acts as a generator by reclaiming the potential energy left in the system due to the presence of material in the mill with a certain angle.

In this type of drive system – which includes a diode bridge rectifier that eliminates the possibility of feeding energy back into the network – the negative speed available to roll back the mill is relatively low. This is because the generative power is limited by the losses in the drive system (ie, the motor and in-

verter/DC link of the frequency converter). ABB also offers the option of a truly four-quadrant drive system with an active rectifier unit, which enables braking energy to be fed back into the network. This option significantly reduces the time required to roll back the mill.

A close-up of the controlled rollback area (from → 6) is shown in → 7. When the mill speed has been ramped down and the mill is in an unbalanced position, the motor first creates a positive torque that just about holds the mill with the charge unbalanced. Slightly reducing the torque changes the direction of rotation, which then causes the mill to gently roll back until the charge is balanced. The data in → 7 clearly show that the torque (applied to the pinion teeth) is always positive during the complete procedure, meaning there can be no backlash between the pinion and ring gear, and contact between the two is always maintained. If backlash were to happen, it would be shown by a drop in torque to zero or below.

In this particular configuration, the motor speed during controlled rollback is only 12.8 rpm, which is about 0.85 percent of nominal speed! In other words, the mill is smoothly rolled back in a controlled manner at a speed of about 0.1 rpm. Even at this very low speed, the system still runs stable thanks to ABB's advanced DTC technology. In addition, the time between reaching zero speed and zero torque (ie, mill stopped and no overshooting) takes about 55 seconds. While

The latest generation of ABB MV frequency converters provides excellent opportunities to improve the grinding process used in the minerals industry.

this is significantly faster than a coast stop, the use of a converter setup with four quadrant capabilities would reduce this figure even further.

8 A coast stop (rocking mill)

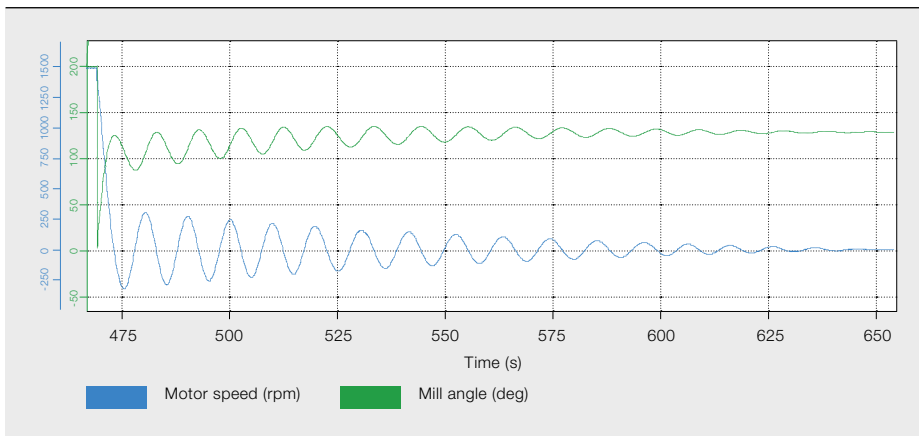

9 Backlash during a coast stop

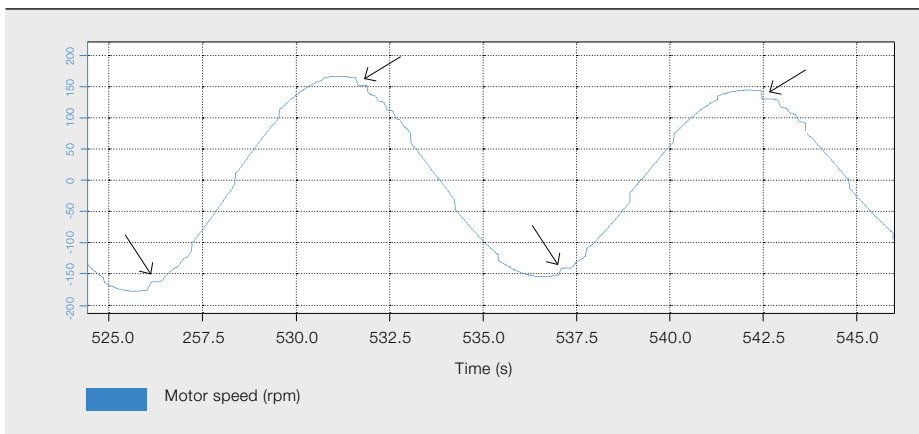

By looking at the angle curve (in → 7), it can be observed that the mill was rolled back by 30 degrees, from about 178 degrees to approximately 148 degrees (ie, the angle curve decreases once the mill speed becomes negative at approximately 630 seconds). This matches perfectly with the measured cascading angle during the startup in → 4.

Coast stop (rocking mill)

To fully appreciate the distinct benefits of variable-speed operation and therefore controlled rollback, a coast stop from nominal speed was tested on the same mill. The test showed that the time taken for the mill to reach a complete standstill, (ie, when the backward and forward rocking of the mill had ceased) after the "stop" command was received was about 180 seconds → 8.

On closer inspection of the motor speed signal (measured by a tachometer on the motor) in → 9, there is evidence of backlash (shown by the arrows) between the teeth of the pinion and the ring gear. The cause of this is as follows: The ring gear drives the motor, which has to be accel-

erated and decelerated due to its inertia. During the deceleration process, the tooth of the ring gear hits the tooth of the pinion several times to break the motor speed. Not only does this cause backlash, but it also severely stresses the gear teeth.

Maintenance functions

For fast, easy and safe maintenance of the mill, ABB has implemented dedicated maintenance functions in the mill controller.

Creeping

Creeping, a common maintenance function for mills, is nothing more than turning the mill at very low speeds for maintenance purposes, such as the visual inspection of bearings or manual positioning for a liner change. In general mills using fixed-speed motors for the main drive system need an auxiliary motor with a reduction gearbox to perform creeping. ABB's mill drive systems can provide high torque at low speed, thereby ensuring creeping is possible with the main drive.

10 A creeping routine

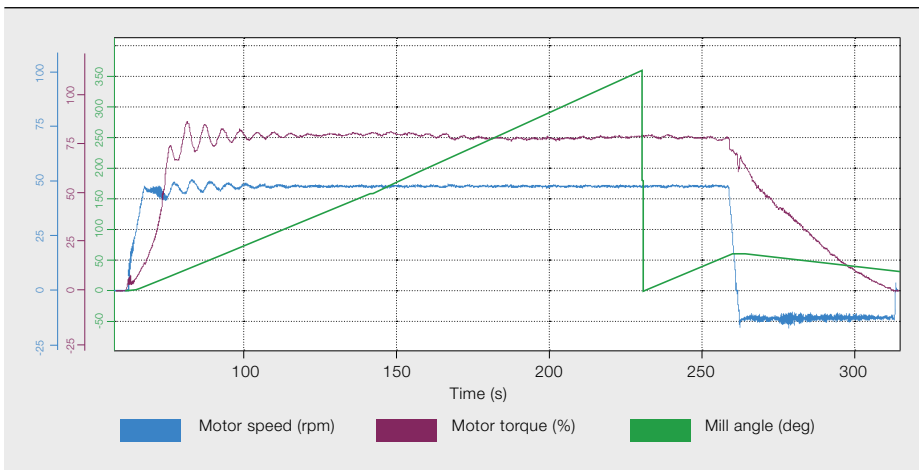

11 Automatic positioning routine with 180 degree angle reference

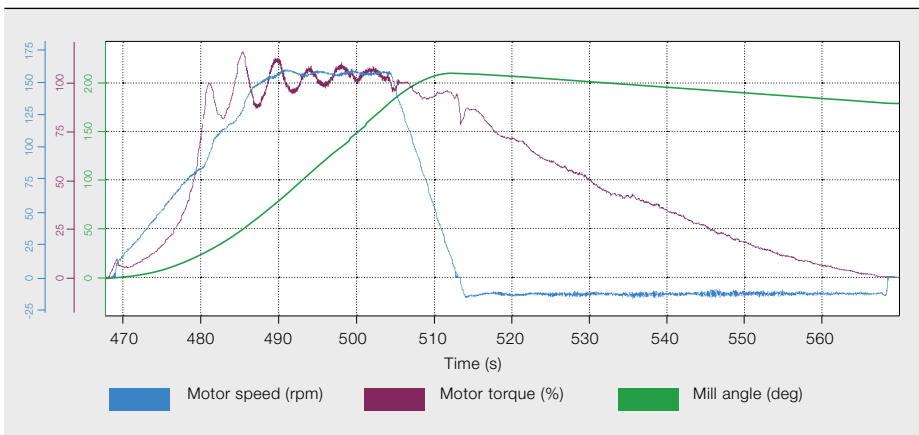

The automatic positioning function allows operators to accurately turn the mill by any desired angle or number of liner rows.

Preferably, the creeping command should be initiated from a local control panel close to the mill, but it can also be activated remotely from the DCS. The start procedure is completely controlled by the mill controller and frozen charge protection is activated when creeping mode is selected. Creeping speed is typically 5 percent of nominal speed but can be adjusted to between 1 and 10 percent after a successful start.

A complete creeping sequence is shown in → 10. The creeping speed is set at 48 rpm or 3.2 percent of nominal speed; cascading is detected at a mill angle of 23.5 degrees and a torque of 73 percent of nominal torque. The operator keeps the mill running at this speed for 420 degrees before initiating a stop command, causing the mill controller to ramp down the speed and perform a controlled rollback until there is no torque remaining in the system before stopping the drive.

Automatic positioning sequence

The automatic positioning function allows operators to accurately turn the mill by any desired angle or number of liner rows. In fact it is a very helpful function during liner replacement because it helps to reduce downtime and increase availability. Initiated by a local control panel or the DCS, the operator preselects the positioning mode, direction of rotation and desired angle or number of liners.

An automatic positioning function requesting a 180-degree turn is illustrated in → 11: The material cascades at 27 degrees; the drive keeps running at low speed for a certain time before ramping down; at zero speed the mill has turned 209 degrees at which point the torque value is 94 percent of nominal torque (meaning the mill is fully loaded); and the drive then runs in reverse, slowly reducing the torque. By the time the drive stops (101.6 seconds later), the mill has turned 179.2 degrees, which translates into an inaccuracy of only 0.5 percent! The optimum positioning speed for this example was set at 158 rpm, which corresponds to 10.5 percent (10 percent is typical) of nominal speed. At this speed, the angle inaccuracies were below 1 percent for all tests.

Deformation protection

Deformation protection is an automatic positioning sequence with a fixed angle reference of 180 degrees. Even if deformation is not a real problem for grinding mills in the minerals industry, the function can still be used during longer mill stops (eg, maintenance) to prevent a frozen charge from occurring. Operators need only preselect a deformation protection mode and the preferred direction of rotation before issuing a start command. The mill controller then takes care of the 180 degree turn in exactly the same way as that illustrated in → 11.

Frozen charge remover

Frozen charges have been known to occur mostly on ball mills. After one has been detected, the frozen material needs to be removed; this is normally done manually and can result in significant downtime.

ABB's dedicated mill functionality not only protects the mill from a dropping frozen charge, but it also offers a patented function called frozen charge remover, which is available in the mill controller

12 Frozen charge remover with controlled rollback

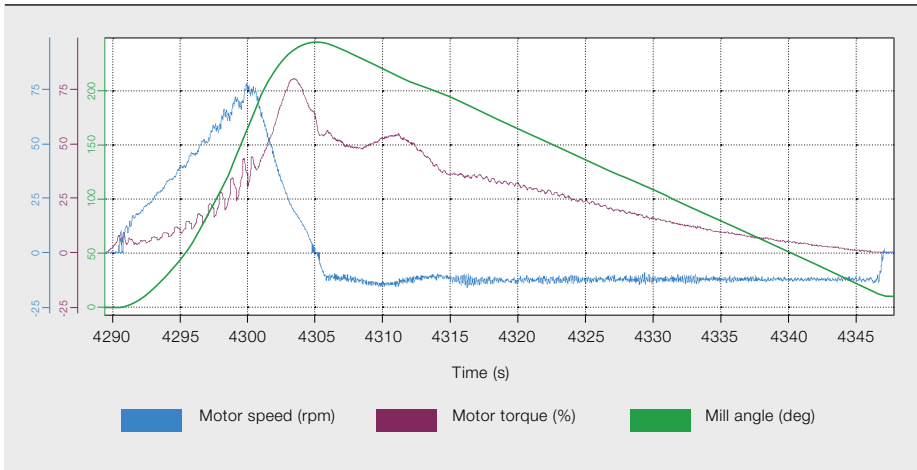

13 Frozen charge remover torque steps

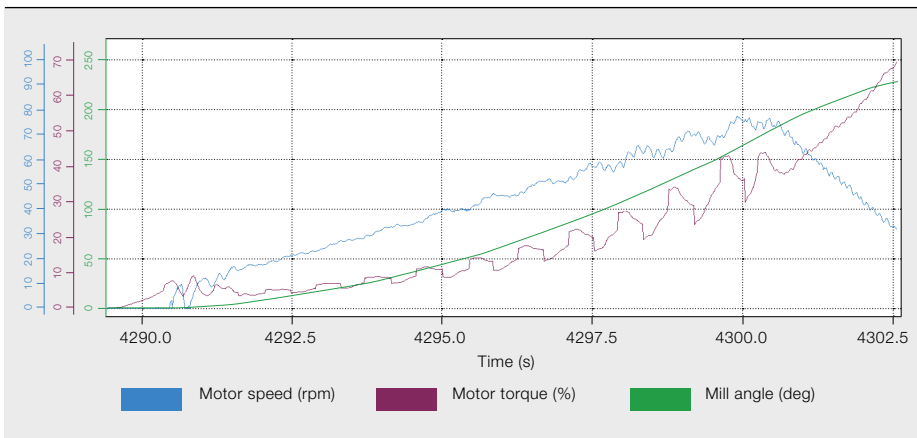

and can only be initiated manually from a local control panel or from the DCS. The frozen charge remover function tries to loosen the material by applying torque steps to the system. The optimal amplitude and duration of these steps are found and set during commissioning. The amplitude of the torque steps are defined in a way that adds a certain percentage

function can be applied in both positive and negative directions.

A complete frozen charge remover sequence with a positive direction of rotation and controlled rollback is shown in → 12 and a close-up of the initial part of the sequence is given in → 13. Torque steps, also reflected by speed

changes, are applied to the system soon after a mill breakaway and are implemented by a sequence of accelerating and decelerating phases, which try to loosen the frozen charge.

The amplitude of the steps is a fixed relative value of the actual torque added to the system and can be adjusted during commissioning.

ABB's dedicated mill functions are capable of adding significant value to grinding mills in terms of efficient operation and maintenance.

of the actual torque to the system, while the protection functions, such as torque and current limits, operate as if the mill was performing under normal conditions. This means the mechanical equipment is never exposed to stress levels exceeding the values that can occur during normal operation. The frozen charge remover

With reference to → 13 the maximum amplitude of the biggest torque step is 19.2 percent of nominal torque. Because torque and speed are always positive

and operation takes place in the same (ie, first) quadrant, no backlash phenomenon can occur between the pinions and ring gear.

To be continued ...

ABB's dedicated mill functions are capable of adding significant value to grinding mills in terms of efficient operation and maintenance. But this drive system is also available for dual pinion mill drives, ie, when two motors are mechanically connected via the mill ring gear and operating together to turn the mill. This obviously requires accurate load sharing. Part two of this article will show, using field measurements, the amazing accuracy of a 2 × 5 MW dual pinion mill drive system.

Marco Ruffli

Maarten van de Vijfeijken

ABB Switzerland Ltd.

Baden-Dättwil, Switzerland

marco.ruffli@ch.abb.com

maarten.vijfeijken@ch.abb.com

Further reading

- [1] Ravani von Ow, T., Bomvisinho, L. (2010). *Use of the latest technology to overcome the demands of mill operation*. Paper presented at the 42nd Annual Canadian Mineral Processors Operators Conference, Ottawa, Canada.
- [2] Ravani von Ow, T., Gerhard, B. (2010). *Ring-gear mills operated with frequency converter (much more than just variable speed)*. Paper presented at the SME annual meeting, Phoenix, Arizona, United States.

Title picture

The latest generation of ABB medium-voltage frequency converters are used in Boliden's Aitik copper concentrator plant in Sweden.