ROBOTICS

Application manual

EtherNet/IP Anybus Adapter



Trace back information:
Workspace 26-1 version a16
Checked in 2026-04-23
Skribenta version 5.6.019

Application manual
EtherNet/IP Anybus Adapter

RobotWare 6.16.03

Document ID: 3HAC050997-001

Revision: F

The information in this manual is subject to change without notice and should not be construed as a commitment by ABB. ABB assumes no responsibility for any errors that may appear in this manual.

Except as may be expressly stated anywhere in this manual, nothing herein shall be construed as any kind of guarantee or warranty by ABB for losses, damage to persons or property, fitness for a specific purpose or the like.

In no event shall ABB be liable for incidental or consequential damages arising from use of this manual and products described herein.

This manual and parts thereof must not be reproduced or copied without ABB's written permission.

Keep for future reference.

Additional copies of this manual may be obtained from ABB.

Original instructions.

© Copyright 2007-2026 ABB. All rights reserved.
Specifications subject to change without notice.

Table of contents

Overview of this manual	7
Product documentation	9
Safety	11
Network security	12
Terminology	13
1 Introduction	15
1.1 What is EtherNet/IP?	15
1.2 The EtherNet/IP anybus adapter for IRC5	16
2 Hardware overview	19
2.1 Main computer DSQC1000	19
3 Software overview	23
3.1 Information about the anybus adapter	23
3.2 CIP routing	25
3.2.1 What is CIP routing?	25
3.2.2 CIP routing for IRC5	26
3.2.3 Information about CIP routing	28
4 Configuring the anybus adapter	31
4.1 Recommended working procedure	31
4.2 Configuring the anybus adapter	32
4.3 Configuring the external scanner	34
4.4 Configuring CIP routing	35
5 System parameters	37
5.1 Introduction	37
5.2 Type Industrial Network	38
5.2.1 Address	38
5.2.2 Subnet Mask	39
5.2.3 Gateway	40
5.3 Type EtherNet/IP Internal Anybus Device	41
5.3.1 Connection Input Size	41
5.3.2 Connection Output Size	42
5.3.3 Connection Timeout Multiplier	43
5.4 Type Route	44
5.4.1 Name	44
5.4.2 Industrial Network	45
5.4.3 Port ID	46
Index	47

This page is intentionally left blank

Overview of this manual

About this manual

This manual describes the option EtherNet/IP Anybus Adapter and contains instructions for the configuration.

Usage

This manual should be used during installation and configuration of the EtherNet/IP anybus adapter and upgrading of the option EtherNet/IP Anybus Adapter.

Who should read this manual?

This manual is intended for

- Personnel that are responsible for installations and configurations of industrial network hardware/software
- Personnel that make the configurations of the I/O system
- System integrators

Prerequisites

The reader should have the required knowledge of

- Mechanical installation work
- Electrical installation work

References

Document references

Reference	Document ID
<i>Application manual - DeviceNet Master/Slave</i>	3HAC050992-001
<i>Operating manual - RobotStudio</i>	3HAC032104-001
<i>Operating manual - IRC5 with FlexPendant</i>	3HAC050941-001
<i>Product manual - IRC5</i>	3HAC047136-001
<i>Technical reference manual - System parameters</i>	3HAC050948-001
<i>Application manual - EtherNet/IP Scanner/Adapter</i>	3HAC050998-001
<i>Product specification - Controller IRC5</i>	3HAC047400-001

Other references

Reference	Description
www.odva.org	The web site of ODVA (Open DeviceNet Vendor Association).
Common Industrial Protocol (CIP) Edition 3.0	ODVA Specification
EtherNet/IP Specification Edition 1.2	ODVA Specification

Continues on next page

Revisions

Revision	Description
-	First edition. Released with RobotWare 6.0.
A	Released with RobotWare 6.01. <ul style="list-style-type: none">• Minor corrections.• System parameter <i>Connection</i> removed from <i>Industrial Network</i>.
B	Released with RobotWare 6.02. <ul style="list-style-type: none">• Updated the path to the template files, see Template I/O configuration file on page 23.
C	Released with RobotWare 6.05. Added new parameter Connection Timeout Multiplier on page 43 in section System Parameters.
D	Released with RobotWare 6.10.01. <ul style="list-style-type: none">• Cfg name removed from entire manual.
E	Released with RobotWare 6.16.02. <ul style="list-style-type: none">• Company name updated to reflect current legal entities.
F	Released with RobotWare 6.16.03. <ul style="list-style-type: none">• Company name updated to reflect current legal entities.

Product documentation

Categories for user documentation from ABB Robotics

The user documentation from ABB Robotics is divided into a number of categories. This listing is based on the type of information in the documents, regardless of whether the products are standard or optional.



Tip

All documents can be found via ABB Robotics One, <https://one.robots.abb.com/en/knowledge-hub>.

Product manuals

Manipulators, controllers, DressPack, and most other hardware is delivered with a **Product manual** that generally contains:

- Safety information.
- Installation and commissioning (descriptions of mechanical installation or electrical connections).
- Maintenance (descriptions of all required preventive maintenance procedures including intervals and expected life time of parts).
- Repair (descriptions of all recommended repair procedures including spare parts).
- Calibration.
- Troubleshooting.
- Decommissioning.
- Reference information (safety standards, unit conversions, screw joints, lists of tools).
- Spare parts list with corresponding figures (or references to separate spare parts lists).
- References to circuit diagrams.

Technical reference manuals

The technical reference manuals describe reference information for robotics products, for example lubrication, the RAPID language, and system parameters.

Application manuals

Specific applications (for example software or hardware options) are described in **Application manuals**. An application manual can describe one or several applications.

An application manual generally contains information about:

- The purpose of the application (what it does and when it is useful).
- What is included (for example cables, I/O boards, RAPID instructions, system parameters, software).
- How to install included or required hardware.

Continues on next page

Continued

- How to use the application.
- Examples of how to use the application.

Operating manuals

The operating manuals describe hands-on handling of the products. The manuals are aimed at those having first-hand operational contact with the product, that is production cell operators, programmers, and troubleshooters.

Safety

Safety regulations

Before beginning mechanical and/or electrical installations, ensure you are familiar with the safety information in the product manuals for the robot.

The integrator of the robot system is responsible for the safety of the robot system.

Network security

Network security

This product is designed to be connected to and to communicate information and data via a network interface. It is your sole responsibility to provide, and continuously ensure, a secure connection between the product and to your network or any other network (as the case may be).

You shall establish and maintain any appropriate measures (such as, but not limited to, the installation of firewalls, application of authentication measures, encryption of data, installation of anti-virus programs, etc) to protect the product, the network, its system and the interface against any kind of security breaches, unauthorized access, interference, intrusion, leakage and/or theft of data or information. ABB Ltd and its entities are not liable for damage and/or loss related to such security breaches, any unauthorized access, interference, intrusion, leakage and/or theft of data or information.

Terminology

Terms

Term	Explanation
Adapter	I/O device that is controlled by a scanner in an Ethernet network. Previously, ABB documentation used the term <i>slave</i> .
CIP	Common Industrial Protocol. Protocol that DeviceNet and EtherNet/IP are based on.
Client	See Scanner. Some documents use the term <i>client</i> , whereas the ABB documentation use the term <i>Scanner</i> for EtherNet/IP industrial network.
Closed communication systems	Fixed number or fixed maximum number of participants linked by a communication system with well-known and fixed properties, and where the risk of unauthorized access is considered negligible (see IEC 61784-1:2021 §3.1.6).
EDS	Electronic Data Sheet. EDS files contain the configuration details relevant to CIP devices.
Explicit Messages	An explicit message is a request or response oriented communication with other devices. These messages are mostly configuration data.
Implicit Messages	Implicit messages are exchanged between I/O connections. No messaging protocol is contained within the message data as with Explicit messaging. Implicit messages can be point to point (unicast) or multicast and are used to transmit application specific I/O data.
Internal adapter	Describes when the robot controller acts as an EtherNet/IP adapter on the EtherNet/IP network.
Internal scanner	Describes when the robot controller acts as an EtherNet/IP scanner on the EtherNet/IP network.
LAN	Connector for Local Area Network.
Master	See term <i>Scanner</i> .
ODVA	Open DeviceNet Vendor Association. Organization for networks built on CIP, for example DeviceNet and EtherNet/IP.
RJ45	Standard Ethernet contact.
Scanner	Controls other I/O devices (adapters) in an Ethernet network. Previously, ABB documentation used the term <i>Master</i> .
Server	See term <i>Adapter</i> . Some documents use the term <i>server</i> , whereas the ABB documentation use the term <i>adapter</i> for EtherNet/IP industrial network.
Slave	See term <i>Adapter</i> .
WAN	Port for Wide Area Network.

This page is intentionally left blank

1 Introduction

1.1 What is EtherNet/IP?

General

EtherNet/IP is a communications link to connect industrial devices.

The EtherNet/IP (EtherNet Industrial Protocol) is managed by ODVA (Open DeviceNet Vendors Association). It is a well established industrial Ethernet communication system with good real-time capabilities. EtherNet/IP extends commercial off-the-shelf Ethernet to the CIP (Common Industrial Protocol)—the same upper-layer protocol and object model found in DeviceNet and ControlNet. CIP allows EtherNet/IP and DeviceNet system integrators and users to apply the same objects and profiles for plug-and-play interoperability among devices from multiple vendors and in multiple sub-nets. Combined, DeviceNet, ControlNet and EtherNet/IP promote transparency from sensors to the enterprise software.

Examples of applications

Here are some examples of EtherNet/IP applications:

- Peer-to-peer data exchange where an EtherNet/IP product can produce and consume messages
- Scanner/adaptor operation defined as a proper subset of peer-to-peer
- An EtherNet/IP product can function as a client or server, or both

Standardization

EtherNet/IP is standardized according to the International standard IEC 61158 and EtherNet/IP devices are certified by ODVA for interoperability and conformance.

Data

The following table specifies a number of EtherNet/IP data.

Network type	Ethernet based Control Level network with CIP application protocol
Installation	Standard Off the Shelf (COTS) Ethernet cables and connectors. 10/100/1000 Mbit/s TX Ethernet cable or fibre optics. RJ45, M12 or fibre optic connectors.
Speed	10, 100, 1000 Mbit/s

EDS file

The configuration process is based on EDS files (Electronic Data Sheet) which are required for each EtherNet/IP device. EDS files are provided by the device manufacturers. It contains electronic descriptions of all relevant communication parameters and objects of the EtherNet/IP device.

1 Introduction

1.2 The EtherNet/IP anybus adapter for IRC5

1.2 The EtherNet/IP anybus adapter for IRC5

General

The EtherNet/IP anybus adapter for IRC5 is inserted into an expansion board on top of the main computer unit in the robot controller.

The EtherNet/IP anybus adapter, DSQC 669, requires the main computer DSQC1000.

Options

With option *EtherNet/IP Anybus Adapter*, the IRC5 controller can act as an adapter on the EtherNet/IP network.



Note

If EtherNet/IP scanner functionality is required, then the option *EtherNet/IP Scanner/Adapter* must be used.

For more information see, *Application manual - EtherNet/IP Scanner/Adapter*.

Continues on next page

Illustration, example

The following figure illustrates an overview of the hardware.

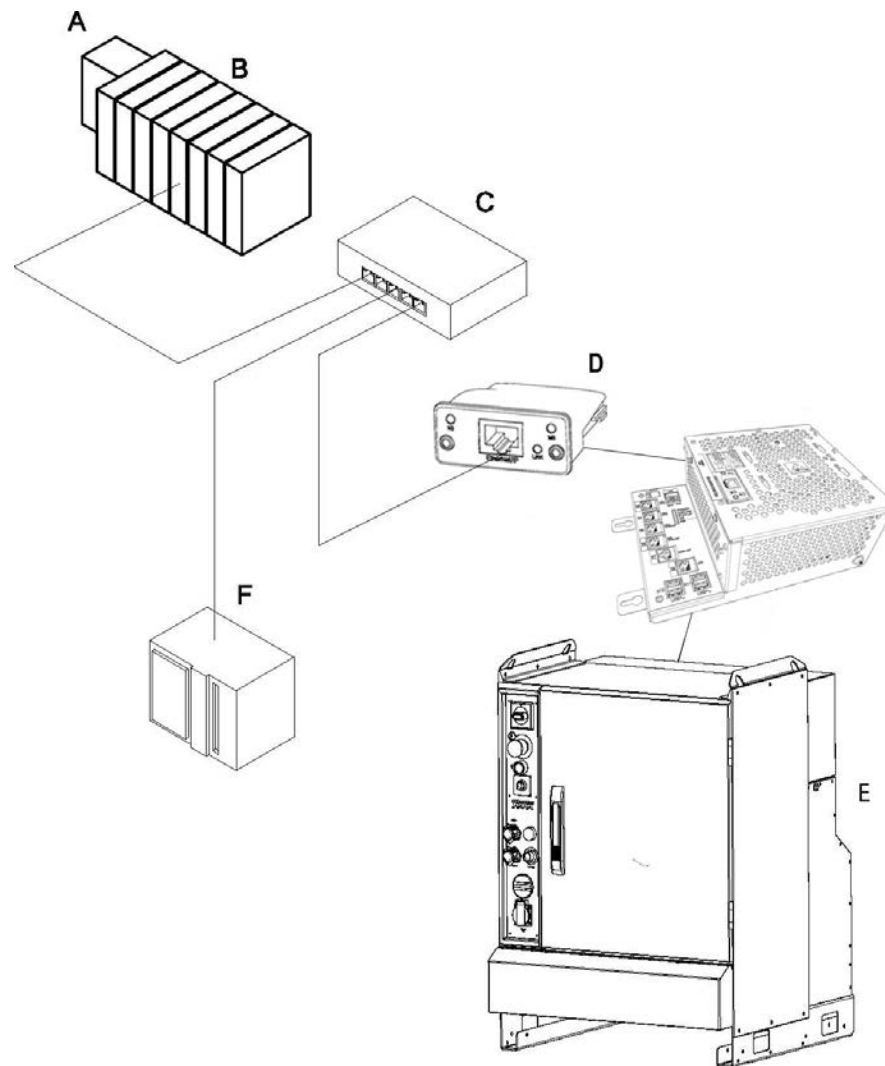

xx140000035

A	Modular EtherNet/IP device
B	Modules for the modular station
C	Ethernet switch
D	EtherNet/IP anybus adapter, DSQC 669
E	IRC5 controller
F	PLC

Specification overview

Item	Specification
Industrial network	EtherNet/IP
Specification revision	EtherNet/IP Specification Edition 1.2
Data rate	10/100 Mbit

Continues on next page

1 Introduction

1.2 The EtherNet/IP anybus adapter for IRC5

Continued

Item	Specification
Connection type	Cyclic
Connection size	Maximum 255 input bytes and 255 output bytes
Transport Classes	Class 1 and 3

2 Hardware overview

2.1 Main computer DSQC1000

Connections

The I/O network is connected to the EtherNet/IP anybus adapter, DSQC 669, on the main computer.

The following figure illustrates the location of the anybus adapter in the main computer unit.

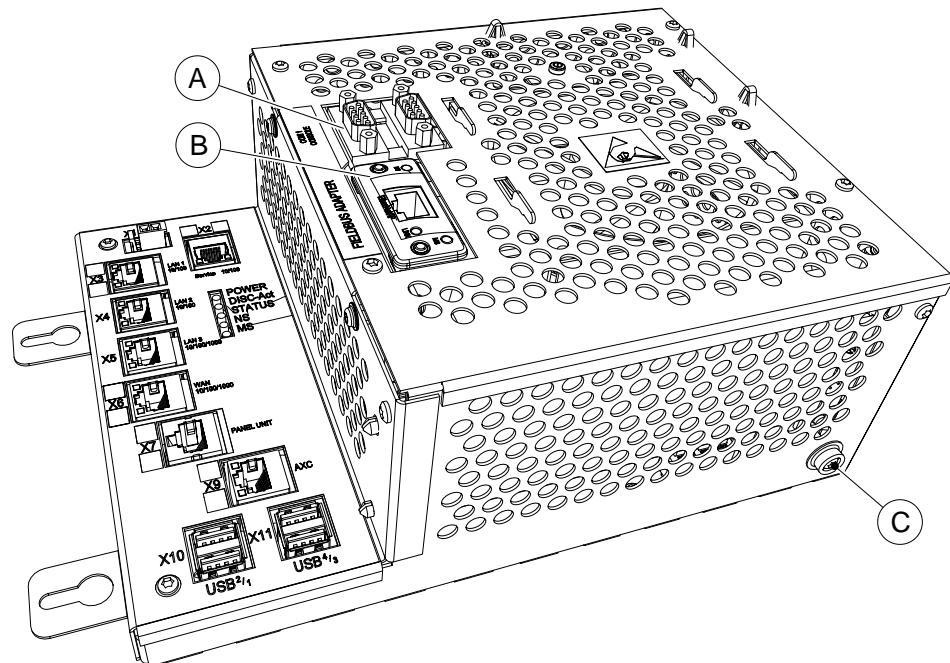

xx1300000841

	Description	Designation	Article number
A	Anybus Adapter / RS232 expansion board	DSQC1003	3HAC046408-001
B	EtherNet/IP Anybus Adapter	DSQC 669	3HAC027652-001
C	Ground connection for ESD bracelet		

Installation of the anybus adapter

For information on how to install and replace the anybus adapter, see *Product manual - IRC5*.

Continues on next page

2 Hardware overview

2.1 Main computer DSQC1000

Continued

Illustration, EtherNet/IP anybus adapter DSQC 669

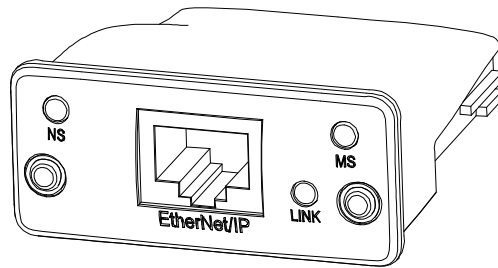

xx0700000097

NS	Network status LED
MS	Module status LED
LINK	Link/Activity
EtherNet/IP	EtherNet/IP interface

LEDs

This section describes the LEDs of the EtherNet/IP anybus adapter.



Note

A test sequence is performed on this LED during start of the adapter.

Network status LED

LED state	Description
OFF	No power or no IP address
GREEN	Online, one or more connections established
GREEN, flashing	Online, no connections established
RED	Duplicate IP address, fatal error
RED flashing	One or more connections timed out

Module status LED

LED state	Description
OFF	No power
GREEN	Controlled by a scanner in run state
GREEN flashing	Not configured, or scanner in idle state
RED	Major fault (exception state, fatal error etc.)
RED flashing	Recoverable fault(s)

Link/Activity LED

LED state	Description
OFF	No link, no activity
GREEN	Link established
GREEN flickering	Activity

Continues on next page

Cable lengths

Permanent link length

The total permanent link length for COTS twisted pair systems is limited to 90 m (298 ft). The permanent link shall conform to ANSI/TIA/EIA-568-B1 according to the EtherNet/IP Specification, see [Other references on page 7](#).

Channel length

The total channel length for COTS twisted pair systems is 100 m (330 ft) including patch cables as defined in ANSI/TIA/EIA-568-B1 according to the EtherNet/IP Specification, see [Other references on page 7](#).

This page is intentionally left blank

3 Software overview

3.1 Information about the anybus adapter

General

To use the EtherNet/IP anybus adapter, the IRC5 controller must be installed with the option *840-1 EtherNet/IP Anybus Adapter*.

The EtherNet/IP anybus adapter can be used to:

- connect the IRC5 controller to a PLC.
- connect the IRC5 controller to another IRC5 controller which acts as a scanner.

Predefined industrial network

When the robot system is installed with the EtherNet/IP Anybus Adapter option, a predefined industrial network with the name *EtherNetIP_Anybus* is created at system startup.

EtherNet/IP Internal Anybus Device

When the robot system is installed with the EtherNet/IP Anybus Adapter option, a predefined *EtherNet/IP Internal Anybus Device* with the name *EN_Internal_Anybus* is created with the size of 64 input bytes and 64 output bytes.

If another input or output size is required, the predefined device *EN_Internal_Anybus* must be changed.

EDS file

An Electronic Data Sheet file, EDS file, is available for the anybus adapter, matching the configuration of the predefined anybus internal adapter device.

The EDS file, *ENIP_FA.eds*, for the anybus adapter can be obtained from the RobotStudio or the IRC5 controller.

- **In the RobotWare installation folder in RobotStudio:** ...*RobotPackages**RobotWare_RPK_<version>*\utility\service\ioconfig\EtherNetIP*ENIP_FA.eds*
- **On the IRC5 Controller:** <SystemName>\PRODUCTS*ENIP_FA.eds*



Note

Navigate to the RobotWare installation folder from the RobotStudio **Add-Ins** tab, by right-clicking on the installed RobotWare version in the **Add-Ins** browser and selecting **Open Package Folder**.

Template I/O configuration file

A template I/O configuration file is available for the internal anybus adapter. The file contains names for all available inputs and outputs. The file can be loaded to the controller, using RobotStudio or the FlexPendant, to facilitate and speed up the configuration.

Continues on next page

3 Software overview

3.1 Information about the anybus adapter

Continued

The I/O template configuration file, *EN_Internal_Anybus.cfg*, can be obtained from the RobotStudio or the IRC5 controller.

- In the RobotWare installation folder in RobotStudio: ...*\RobotPackages\RobotWare_RPK_<version>\utility\service\ioconfig\EtherNetIP*
- On the IRC5 Controller: *<SystemName>\PRODUCTS\<RobotWare_xx.xx.xxxx>\utility\service\ioconfig\EtherNetIP*



Note

Navigate to the RobotWare installation folder from the RobotStudio **Add-Ins** tab, by right-clicking on the installed RobotWare version in the **Add-Ins** browser and selecting **Open Package Folder**.

Input/output assembly

The EtherNet/IP anybus adapter has the following assembly values.

Assembly	Value
Output	150
Input	100
Configuration	0

I/O connection

Cyclic I/O connection is supported and the size of the I/O connection is defined by the EtherNet/IP internal anybus device, *EN_Internal_Anybus*.



Note

If the EtherNet/IP anybus adapter loses connection with its scanner, the configured input signals are cleared (reset to zero). The output signals are kept and are possible to change.

When the connection is re-established, the scanner updates the input and output signals.

3.2 CIP routing

3.2.1 What is CIP routing?

General

CIP (Common Industrial Protocol) routing makes it possible to collect and view status or other information from different devices placed on several CIP networks at a single or several operator stations. A CIP router allows sending messages between CIP networks.

CIP standardization

CIP is standardized by ODVA. CIP devices are certified by ODVA for interoperability and conformance.

3 Software overview

3.2.2 CIP routing for IRC5

3.2.2 CIP routing for IRC5

Hardware overview

Messages are sent from one device on an EtherNet/IP network to one or several devices on a DeviceNet network.



Note

In IRC5 the originator of a message has to be connected on the EtherNet/IP anybus adapter network while its targets have to be on a DeviceNet network.

Illustration, example

The following figure illustrates an overview of the hardware.

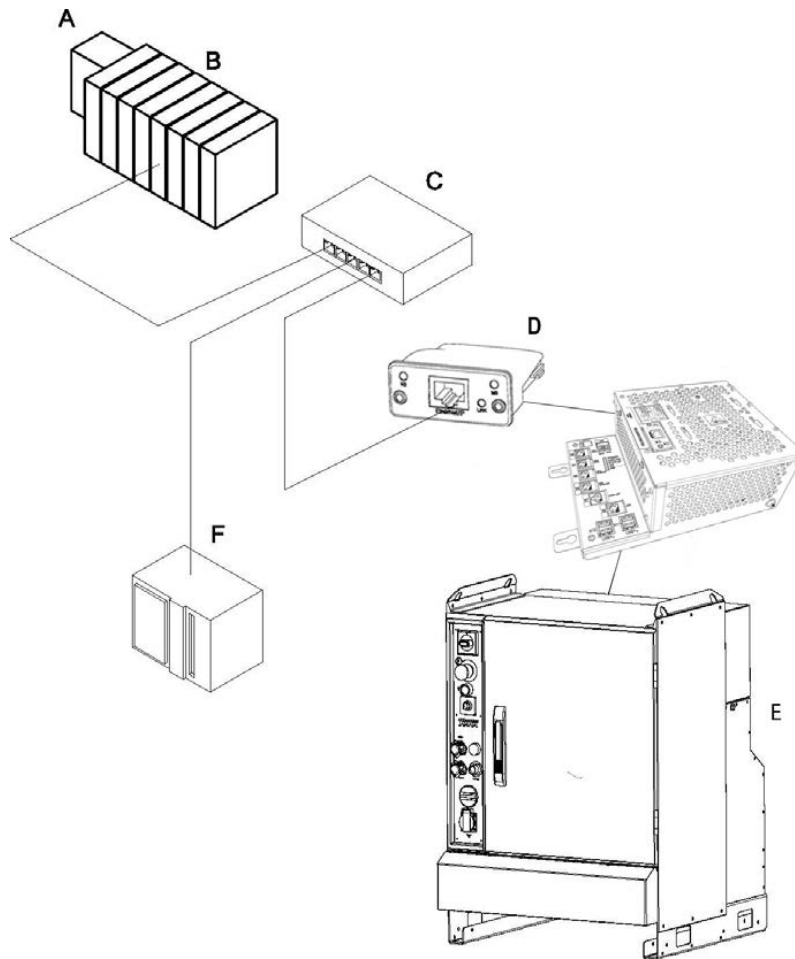

xx140000035

A	Modular EtherNet/IP Device
B	Modules for the modular station
C	Ethernet switch
D	EtherNet/IP anybus adapter, DSQC 669
E	IRC5 controller

Continues on next page

F	PLC
---	-----

For information about the DeviceNet hardware, refer to *Application manual - DeviceNet Master/Slave*.

Specification overview

Item	Specification
CIP network types	EtherNet/IP to DeviceNet
Route type	Unconnected send

3 Software overview

3.2.3 Information about CIP routing

3.2.3 Information about CIP routing

General

The IRC5 controller must be installed with software that supports the use of the CIP networks. To communicate through the EtherNet/IP network the EtherNet/IP Anybus Adapter option must be installed, while DeviceNet communication requires the DeviceNet Master/Slave option to be installed.

The function of CIP routing

A message on one route can be forwarded to any of the other defined routes. The sent message contains the destination device and port number, and from that information the suitable destination route is selected. All defined CIP routes will together compose a *virtual* CIP router. During the configuration of a route the port number will be coupled with its network and thereby with its hardware.

Configuration

A routing configuration requires that two or more routes are defined. One route bonds the required CIP port to a CIP network. Messages can be forwarded to any of the networks having a CIP port defined.

The following table gives descriptions of all route specific types.

Defining...	Description
CIP Route	A route identity links the required CIP port to a destination network.

Port identity

The port identity, required by the CIP route protocol, is used in order to find a destination network. By the configuration the port identity is tied to a specific network. Each network has its own unique port identity.

EDS file

For information about the location of the EDS files, see [EDS file on page 23](#).

The EDS file contains information necessary for the CIP routing.

Example, EDS file

An example from an EDS file that shows the configurations of the ports:

```
[Port]
Port1 =
  TCP,$ port type name
  "TCP/IP", $ name of port
  "20 F5 24 01", $ instance one of the TCP/IP interface $ object
  2;$ port number
```

Limitations

CIP routing has the following limitations:

Item	Description
<i>Max. routes</i>	A maximum of 5 routes can be defined.

Continues on next page

Item	Description
<i>Unconnected send connection</i>	Only unconnected send service routing is supported.
<i>Explicit message connection</i>	This is the only supported connection type. In order to see or use a DeviceNet device it has to allow <i>Explicit message connection</i> .
<i>I/O message connection</i>	Unsupported connection type.
<i>Single hop</i>	The router cannot act as an intermediate hop, that is, the router cannot forward a message to its target when it has to go through another router.
<i>EtherNet/IP</i>	An EtherNet/IP route only has server capability. A server will only respond to a received request.
<i>DeviceNet</i>	A DeviceNet route only has client capability. A client will issue a request and expects an answer to its request.

This page is intentionally left blank

4 Configuring the anybus adapter

4.1 Recommended working procedure

General

This section describes the recommended working procedure when installing and configuring the EtherNet/IP anybus adapter. The working procedure helps to understand the dependencies between the different steps.

When the IRC5 controller with the EtherNet/IP anybus adapter is connected to an external scanner, the IRC5 controller acts as an adapter on the EtherNet/IP network.

Basic steps

Use this procedure to install and configure the EtherNet/IP anybus adapter.

	Action	See
1	Create and configure the anybus adapter in the IRC5 controller using RobotStudio or the FlexPendant.	Configuring the anybus adapter on page 32
2	Configure the external scanner using the vendor specific configuration tool.	Configuring the external scanner on page 34

Additional configuration

Action	See
CIP routing configuration.	Configuring CIP routing on page 35

4 Configuring the anybus adapter

4.2 Configuring the anybus adapter

4.2 Configuring the anybus adapter

General

A device is required in order to be able to create the signals attached to the anybus adapter.

The size of the anybus adapter determines how many signals that can be attached.

Anybus adapter configuration

Use this procedure to install and configure the EtherNet/IP anybus adapter in the IRC5 controller, using RobotStudio.

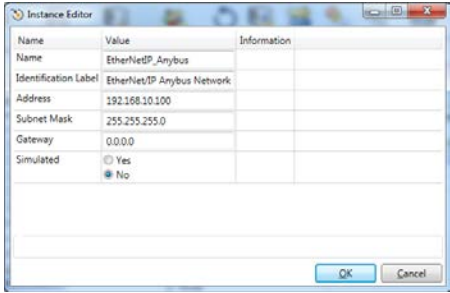
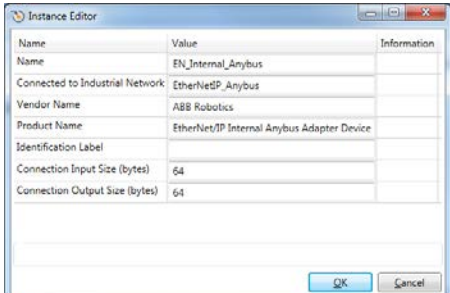
	Action	Note
1	Start RobotStudio and connect to the IRC5 controller. Request write access.	
2	Open the Configuration Editor and select I/O System.	For more information about the parameters, see System parameters on page 37 .
3	<p>In the Type list click Industrial Network and edit the parameter <i>EtherNet/IP_Anybus</i>.</p> <p>Enter the IP address for the industrial network.</p> <ul style="list-style-type: none"> • Identification Label, user defined. • Address, user defined. • Subnet Mask, user defined. • Gateway, user defined. <p>Click OK.</p>	 <p>en1400002036</p>
4	<p>If the size needs to be changed:</p> <p>In the Type list click Ethernet/IP Internal Anybus Device and edit the parameter <i>EN_Internal_Anybus</i>.</p> <p>Edit the parameter values for the internal anybus device.</p> <ul style="list-style-type: none"> • Connection Input Size and Connection Output Size, change the default values to the desired size. <p>Click OK.</p>	 <p>en1400002037</p>

Continues on next page

4 Configuring the anybus adapter

4.2 Configuring the anybus adapter

Continued

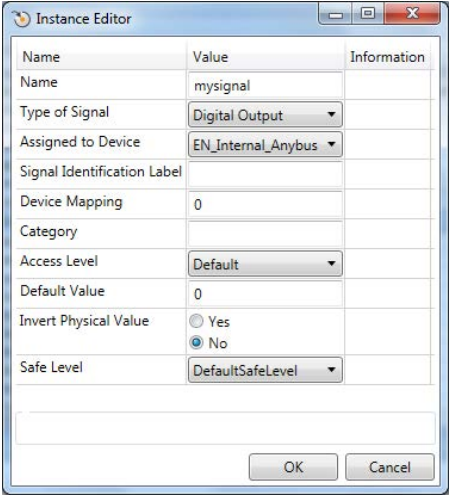
	Action	Note
5	In the Type list click Signal . Add I/O signals for the EN_Internal_Anybus device.	 <p>en1400002038</p>
6	Restart the controller. Now the IRC5 controller is ready to be contacted from an EtherNet/IP scanner.	

Viewing the MAC address

After the configuration, it is possible to view the MAC address of the EtherNet/IP anybus adapter on FlexPendant in one of the following ways:

Using the Industrial Networks view.

	Action	Note
1	In the ABB menu, tap Inputs and Outputs .	The list of most common I/O signals is displayed.
2	Tap View and select Industrial Networks .	The list of available industrial networks is displayed.
3	Tap EtherNetIP_Anybus .	
4	Tap I/O Device Identification .	The MAC address of EtherNet/IP anybus adapter is displayed along with the other details.

Using the I/O Devices view.

	Action	Note
1	In the ABB menu, tap Inputs and Outputs .	The list of most common I/O signals is displayed.
2	Tap View and select I/O Devices .	The list of available I/O devices is displayed.
3	Tap the I/O device created to Ethernet/IP anybus adapter.	
4	Tap Actions and select I/O Device Identification .	The MAC address of EtherNet/IP anybus adapter is displayed along with the other details.

4 Configuring the anybus adapter

4.3 Configuring the external scanner

4.3 Configuring the external scanner

General

The external scanner is configured by using the vendor specific configuration tool that is delivered, or bought, together with the scanner.

The tool is used to specify all the devices in the EtherNet/IP network. One of the devices is the anybus adapter of the IRC5 controller. If it is necessary to import the EDS file that describes the internal adapter device to configure the anybus adapter device in the vendor specific configuration, see [EDS file on page 23](#).

External scanner configuration

This procedure describes the general steps that needs to be performed when configuring an external scanner, independent of which tool is used.

	Action
1	<p>Use the external master configuration tool to:</p> <ul style="list-style-type: none">• Specify the address of the external EtherNet/IP scanner.• Import the EDS files for the internal adapter device and all other types of devices in the network.• Add the IRC5 controller anybus adapter device and set the same EtherNet/IP address as in the IRC5 controller.• Add any other I/O devices into the industrial network structure.• Add signals for all I/O devices including the anybus adapter device.

4.4 Configuring CIP routing

Introduction

The following figure illustrates an example of how to use CIP routing, and shows an IRC5 controller with connections to the networks. For each of the CIP hardware devices (C and E), route parameters have to be defined.

The route parameters are added to the I/O configuration of the IRC5 controller.

Example

In this example the possible route is :

- From *Port ID: 2* to *Port ID: 3*, and further to equipment on the *DeviceNet* network.

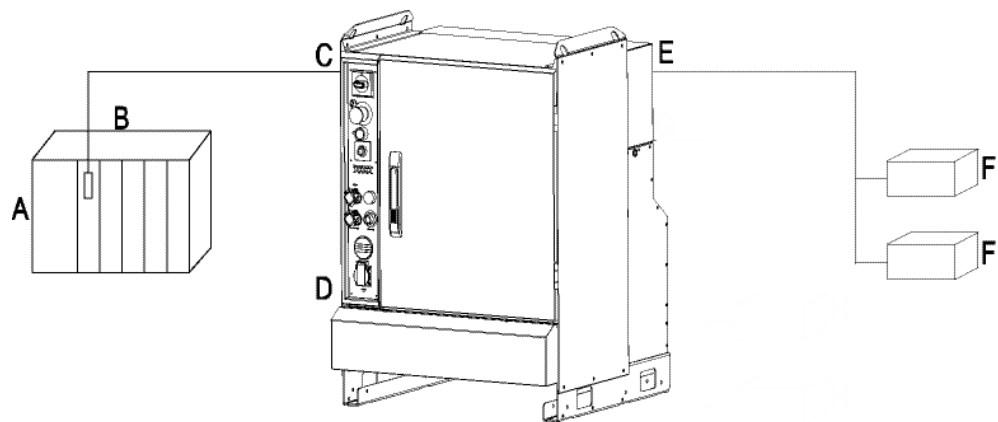

xx070000393

A	PLC
B	EtherNet/IP scanner
C	EtherNet/IP anybus adapter with <i>Port ID: 2</i> .
D	IRC5 controller
E	<i>DeviceNet</i> master with <i>Port ID: 3</i> .
F	User equipment on <i>DeviceNet</i> , for example arc welding or spot welding.



Note

The maximum number of ports depends on total number of DeviceNet channels - that is, 2 + number of DeviceNet channels, see [Port ID on page 46](#).

Configuring the CIP routes

Use this procedure to add CIP routes, using RobotStudio.

	Action	Note
1	Start RobotStudio and connect to the IRC5 controller. Request write access.	
2	Open the Configuration Editor and select I/O System .	For more information about the parameters, see System parameters on page 37 .

Continues on next page

4 Configuring the anybus adapter

4.4 Configuring CIP routing

Continued

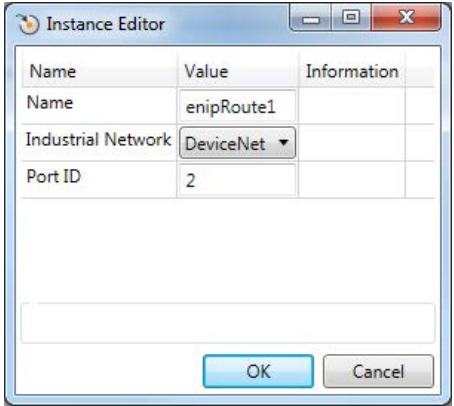
	Action	Note
3	<p>In the Type list click Route, right-click in the workspace and select New Route. Add a route to the EtherNet/IP anybus adapter.</p> <ul style="list-style-type: none">• Name, user defined.• Industrial Network, shall be <i>EtherNet/IP_Anybus</i>.• Port ID, user defined. <p>Click OK.</p>	
4	<p>In the Type list click Route, right-click in the workspace and select New Route. Add routes to the DeviceNet network.</p> <ul style="list-style-type: none">• Name, user defined.• Industrial Network, select the DeviceNet network.• Port ID, user defined. <p>Click OK.</p>	 <p>en1400002325</p>
5	Restart the controller.	

5 System parameters

5.1 Introduction

About the system parameters

There are both EtherNet/IP specific parameters and more general parameters. This chapter describes all EtherNet/IP specific system parameters. The parameters are divided into the type they belong to.

For information about other system parameters, see *Technical reference manual - System parameters*.

EtherNet/IP system parameters

Industrial Network

These parameters belong to the type *Industrial Network* in the topic *I/O System*.

Parameter	For more information, see ...
Name	3HAC050948-001
Identification Label	3HAC050948-001
Address	Address on page 38
Subnet Mask	Subnet Mask on page 39
Gateway	Gateway on page 40
Simulated	3HAC050948-001

EtherNet/IP Internal Anybus Device

These parameters belong to the type *EtherNet/IP Internal Anybus Device* in the topic *I/O System*.

Parameter	For more information, see ...
Name	3HAC050948-001
Connected to Industrial Network	3HAC050948-001
Vendor Name	3HAC050948-001
Product Name	3HAC050948-001
Connection Input Size	Connection Input Size on page 41
Connection Output Size	Connection Output Size on page 42
Connection Timeout Multiplier	3HAC050948-001

Route

These parameters belong to the type *Route* in the topic *I/O System*.

Parameter	For more information, see ...
Name	3HAC050948-001
Industrial Network	Industrial Network on page 45
Port ID	Port ID on page 46

5 System parameters

5.2.1 Address

EtherNet/IP Anybus Adapter

5.2 Type Industrial Network

5.2.1 Address

Parent

Address belongs to the type *Industrial Network*, in the topic *I/O System*.

Description

The parameter *Address* specifies the IP address of the EtherNet/IP anybus adapter on the network. This IP address is used by an external scanner to set up a connection to the anybus adapter.

Usage

The parameter *Address* is used to set the IP address of the IRC5 controller on the used network interface (decided with the *Connection* parameter).

Prerequisites

The option *EtherNet/IP Anybus Adapter* must be installed.

Default value

0.0.0.0

Allowed values

0.0.0.0 - 255.255.255.255

5.2.2 Subnet Mask

Parent

Subnet Mask belongs to the type *Industrial Network*, in the topic *I/O System*.

Description

The parameter *Subnet Mask* is used to determine what subnet the IP address belongs to.

Usage

The parameter *Subnet Mask* is used to divide the network into logical subnets.

Prerequisites

The option *EtherNet/IP Anybus Adapter* must be installed.

Default value

The default value is an empty string.

Allowed values

0.0.0.0 - 255.255.255.255

5 System parameters

5.2.3 Gateway

EtherNet/IP Anybus Adapter

5.2.3 Gateway

Parent

Gateway belongs to the type *Industrial Network*, in the topic *I/O System*.

Description

The parameter *Gateway* specifies the node on the network that serves as an entrance to another network.

Usage

Use this parameter if the EtherNet/IP traffic needs to be routed to another network. The parameter value is the address to a physical gateway on the EtherNet/IP network.

Prerequisites

The option *EtherNet/IP Anybus Adapter* must be installed.

Default value

Empty

Allowed values

0.0.0.0 - 255.255.255.255

5.3 Type EtherNet/IP Internal Anybus Device

5.3.1 Connection Input Size

Parent

Connection Input Size belongs to the type *EtherNet/IP Internal Anybus Device*, in the topic *I/O System*.

Description

Connection Input Size defines the data size in bytes for the input area received from the connected EtherNet/IP scanner.

Usage

Connection Input Size is an EtherNet/IP specific parameter.

Prerequisites

The option *EtherNet/IP Anybus Adapter* must be installed.

Default value

The default value is 64 bytes (512 signal bits).

Allowed values

Allowed values are the integers 0-255 (0-2040 signal bits), specifying the data size in bytes.

5 System parameters

5.3.2 Connection Output Size

5.3.2 Connection Output Size

Parent

Connection Output Size belongs to the type *EtherNet/IP Internal Anybus Device*, in the topic *I/O System*.

Description

Connection Output Size defines the data size in bytes for the output area sent to the connected EtherNet/IP scanner.

Usage

Connection Output Size is an EtherNet/IP specific parameter.

Prerequisites

The option *EtherNet/IP Anybus Adapter* must be installed.

Default value

The default value is 64 bytes (512 signal bits).

Allowed values

Allowed values are the integers 0-255 (0-2040 signal bits), specifying the data size in bytes.

5.3.3 Connection Timeout Multiplier

Parent

Connection Timeout Multiplier belongs to the type *Device*, in the topic *I/O System*.

Description

Connection Timeout Multiplier specifies the multiplier applied to the expected packet rate value to derive the value for the Inactivity/Watchdog Timer.

Usage

The *Connection Timeout Multiplier* is a number among 4, 8, 16, 32, 64, 128, 256. It is used together with RPI to calculate the timeout on connections. *RPI* multiplied by *Connection Timeout Multiplier* gives the maximum time before dropping the connection.

**Note**

For the IRB 14000 and IRB 14050 robots this parameter may have to be tuned depending on your network setup.

Allowed values

Allowed values are 4, 8, 16, 32, 64, 128, 256, 512.

Default value is 4.

5 System parameters

5.4.1 Name

5.4 Type Route

5.4.1 Name

Parent

Name belongs to the type *Route*, in the topic *I/O System*.

Description

The parameter *Name* specifies the name of the route.

Usage

Name specifies a route, to which the route messages can be received or sent to.

Prerequisites

The options *EtherNet/IP Anybus Adapter* and *DeviceNet Master/Slave* must be installed.

Default value

The default value is an empty string

Allowed values

The value can be a string of characters.

5.4.2 Industrial Network

Parent

Industrial Network belongs to the type *Route*, in the topic *I/O System*.

Description

The parameter *Industrial Network* specifies the name of the industrial network.

Usage

Industrial Network shows which network is associated to a certain port.

Prerequisites

The options *EtherNet/IP Anybus Adapter* and *DeviceNet Master/Slave* must be installed.

Default value

The default value is an empty string.

Allowed values

The value can be any defined I/O network name.

5 System parameters

5.4.3 Port ID

5.4.3 Port ID

Parent

Port ID belongs to the type *Route*, in the topic *I/O System*.

Description

The parameter *Port ID* specifies the port of the I/O network.

Usage

Port ID is used in the CIP routing path.

Prerequisites

The options *EtherNet/IP Anybus Adapter* and *DeviceNet Master/Slave* must be installed.

Default value

The default value is 2.

Allowed values

The value can be from 2 to 6.



Note

Value 1 is reserved and is not allowed to use.

Index

A

Address, 38

C

cable length, 21

channel length, 21

CIP, 15

CIP router, 25

CIP routing, 25

 CIP port, 28

 configuration, 28, 35

 function, 28

 limitations, 28

 port identity, 28

Common Industrial Protocol, 25

configuration, CIP routing, 35

ControlNet, 15

D

DeviceNet, 15

DSQC 669, 16, 20

E

EDS file, 15, 23, 28

EtherNet/IP, 15

 data, 15

 specification, 17

 standardization, 15

EtherNet/IP anybus adapter, 16

G

Gateway, 40

I

I/O connection, 24

 cyclic, 24

integrator responsibility, 11

Internal Anybus Device, 23

L

LED, 20

 link/activity, 20

 module status, 20

 network status, 20

 test, 20

M

MAC address, 33

N

network security, 12

O

ODVA, 15

P

predefined industrial network, 23

S

safety, 11

Subnet Mask, 39

system integrator requirements, 11

system parameters

 Address, 38

 Connection Timeout Multiplier, 43

 Gateway, 40

 Industrial Network, 45

 Name, 44

 Port ID, 46

 Subnet Mask, 39

T

template I/O configuration file, 23

topic I/O System

 Industrial Network, 23, 37

 Internal anybus device, 23

 Internal Anybus device, 37

 Route, 37



ABB Robotics Sweden AB
S-721 71 VÄSTERÅS, Sweden
Telephone +46 10-732 50 00

ABB Robotics Norway AS
Nordlysvegen 7, N-4340 BRYNE, Norway
Box 265, N-4349 BRYNE, Norway
Telephone: +47 22 87 2000

ABB Robotics (Shanghai) Limited
No. 39, 99 Miaoqiao Road,
Pudong New Area,
Shanghai, 201315, China
Telephone: +86 21 6105 6666

ABB Robotics LLC
1250 Brown Road
Auburn Hills, MI 48326
USA
Telephone: +1 248 391 9000

abb.com/robotics