

Effective: February 1999
Supersedes I.L. 41-347.12B, Dated November 1998
() Denotes Change Since Previous Issue

Type HU and HU-1 Transformer Differential Relays

Class 1E Application



Before putting relays into service, remove all blocking which may have been inserted for the purpose of securing the parts during shipment, make sure that all moving parts operate freely, inspect the contacts to see that they are clean and close properly, and operate the relay to check the settings and electrical connections.

■ APPLICATION

These relays have been specially designed and tested to establish their suitability for Class 1E applications. These relays have been specially designed and tested to establish their suitability for Class 1E applications in accordance with the ABB Power T&D Company program for Class 1E Qualification Testing as detailed in bulletin STR-1.

“Class 1E” is the safety classification of the electric equipment and systems in nuclear power generating stations that are essential to emergency shutdown of the reactor, containment isolation, cooling of the reactor, and heat removal from the containment and reactor, or otherwise are essential in preventing significant release of radioactive material to the environment.

The types HU and HU-1 relays are high-speed relays used in the differential protection of transformers. These relays can be applied where the magnetizing inrush current to the transformers is severe.

Current transformer ratio error should not exceed 10% with maximum symmetrical external fault current flowing and the maximum symmetrical error current which is flowing in the differential circuit on external faults should not exceed 10 times relay tap setting.

The HU-1 relay has three restraint transformers and associated rows of taps; whereas, the HU relay has one less restraint transformer and two rows of taps. Otherwise the two relays are identical. Three-winding banks normally require the HU-1 relay, although the auto-transformer application uses the HU if the tertiary is not loaded.

Both the HU or the HU-1 are available with a sensitivity of either 30% or 35% times tap. The 30%-sensitivity relay satisfactorily handles up to 15% mismatch (e.g. $\pm 10\%$ transformer tap changing plus 5% ct mismatch). The 35%-sensitivity relay handles as much as 20% mismatch. See figure 7 for a comparison of the characteristics of the two sensitivities. Any of the relays may be recalibrated **in the field to obtain either** characteristic.

Ordinarily the 30%-sensitivity relay will suffice; however, where ct mismatch is abnormally high or where the transformer tap-changing range exceeds 10%, this calibration may be too sensitive.

■ CONSTRUCTION

The types HU and HU-1 relays consist of a differential unit (DU), a harmonic-restraint unit (HRU), an indicating instantaneous trip unit (IIT) and an indicating contactor switch (ICS). The principal parts of the relay and their locations are shown in figures 1, 2, 3, and 4.

All possible contingencies which may arise during installation, operation or maintenance, and all details and variations of this equipment do not purport to be covered by these instructions. If further information is desired by purchaser regarding this particular installation, operation or maintenance of this equipment, the local ABB representative should be contacted.

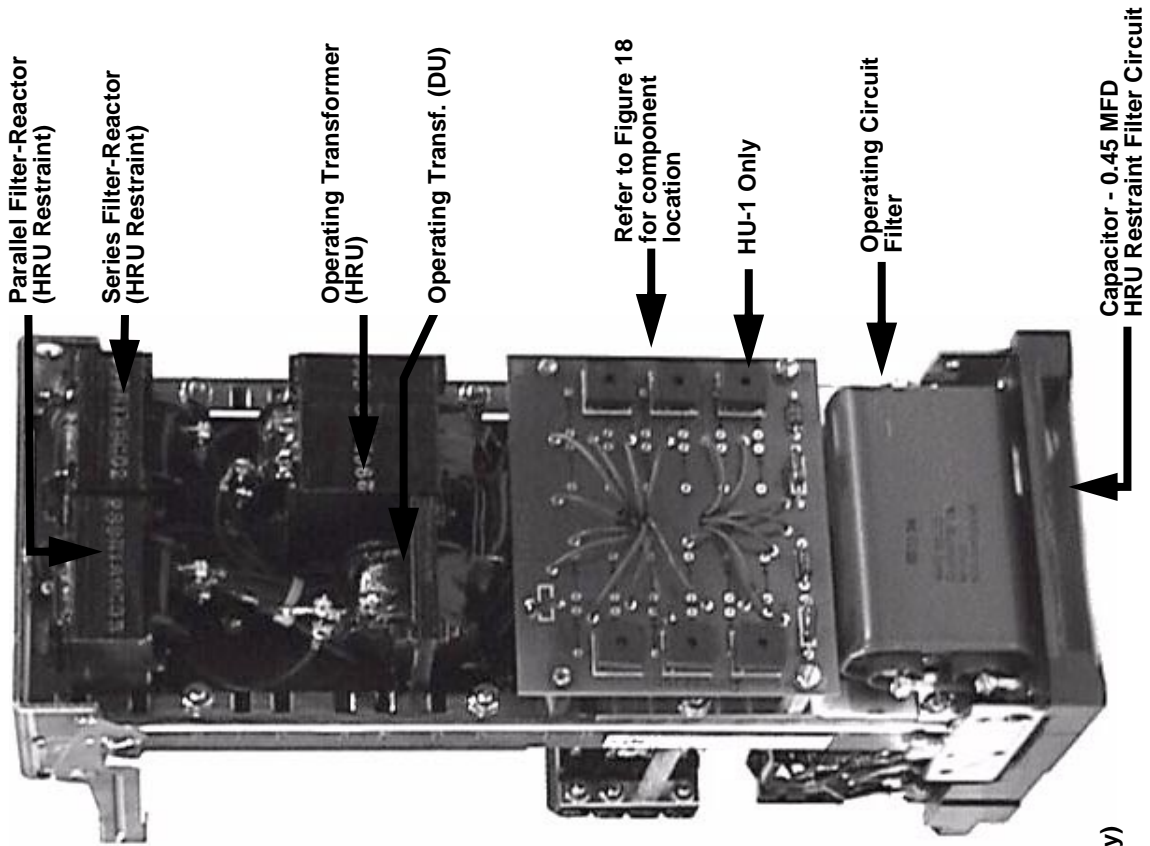

Figure 2. Type HU, HU-1 Relays - Rear View Photo

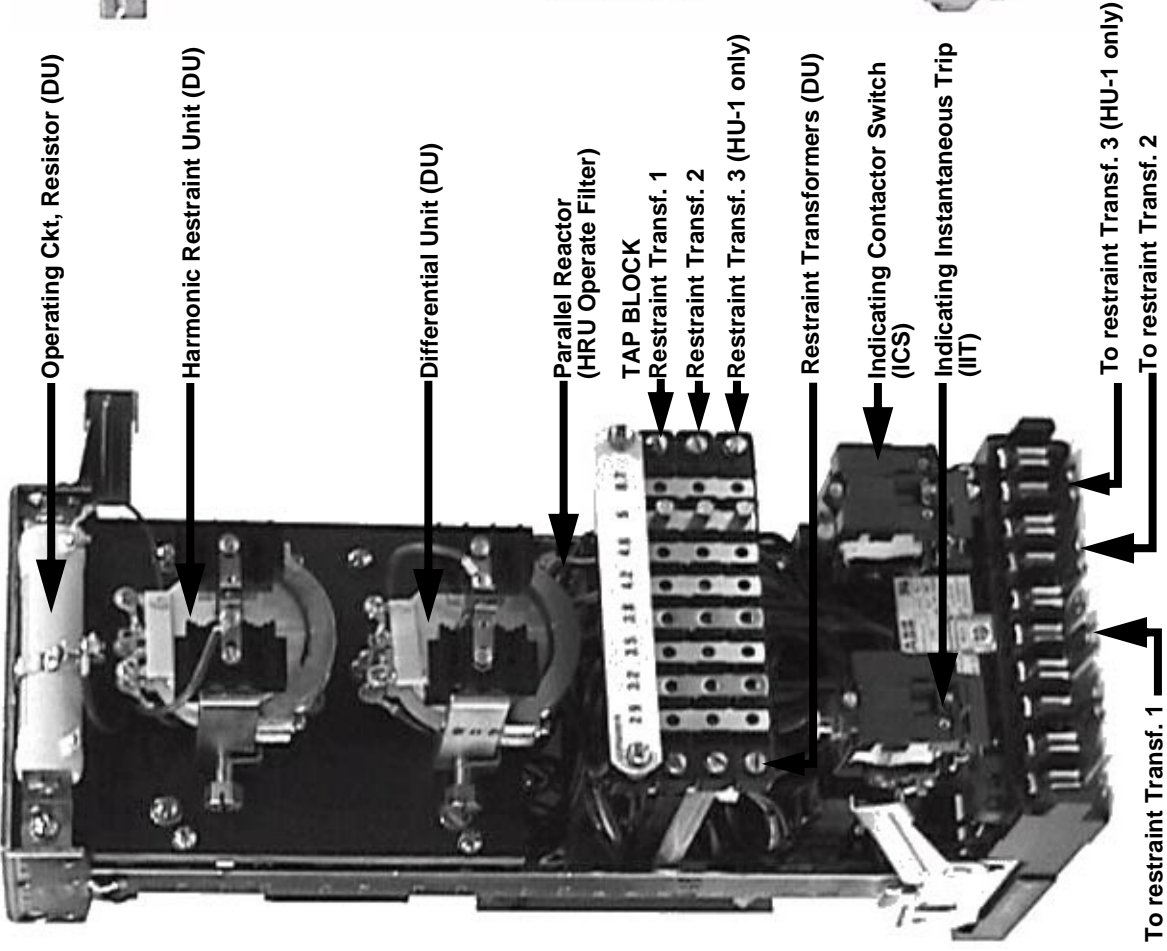

Figure 1. Type HU, HU-1 Relays - Front View Photo

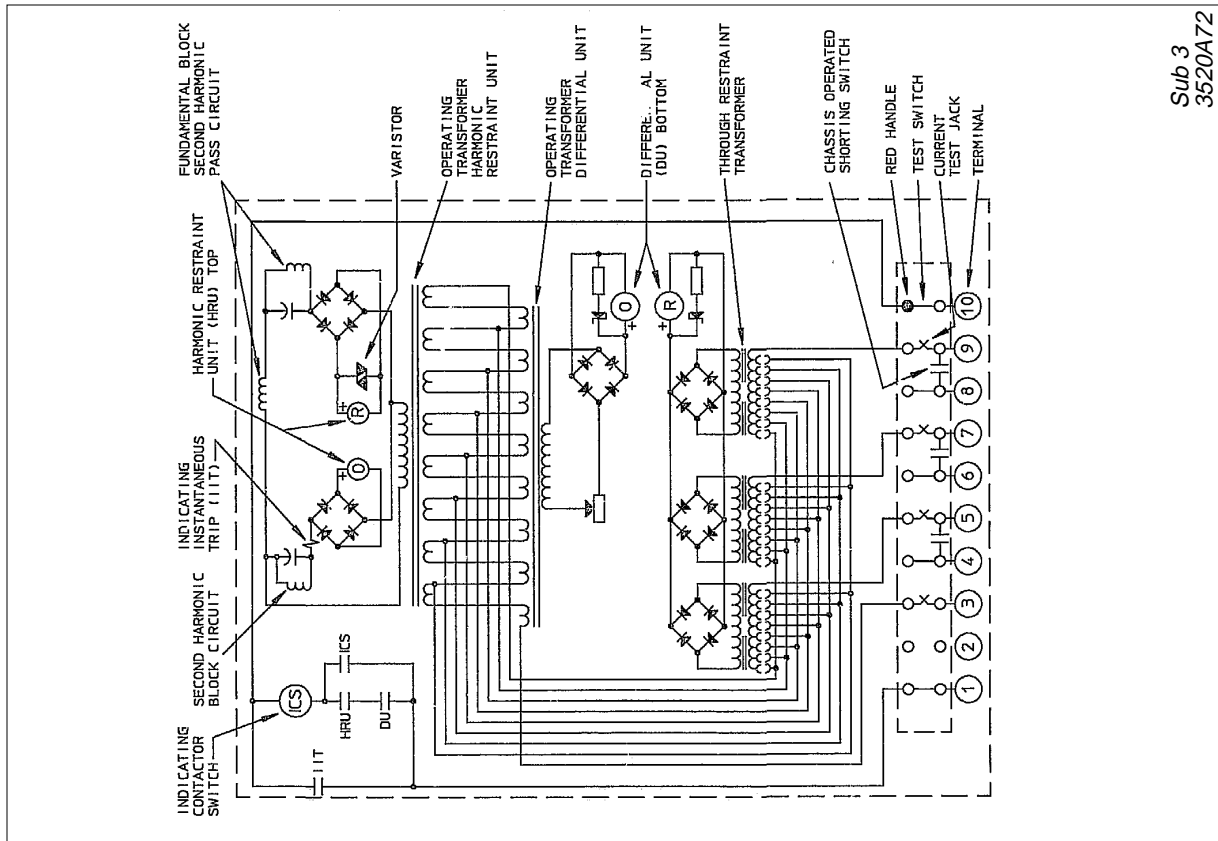

Figure 4. Internal Schematic of the Type HU-1 Relay in FT-31 Case.

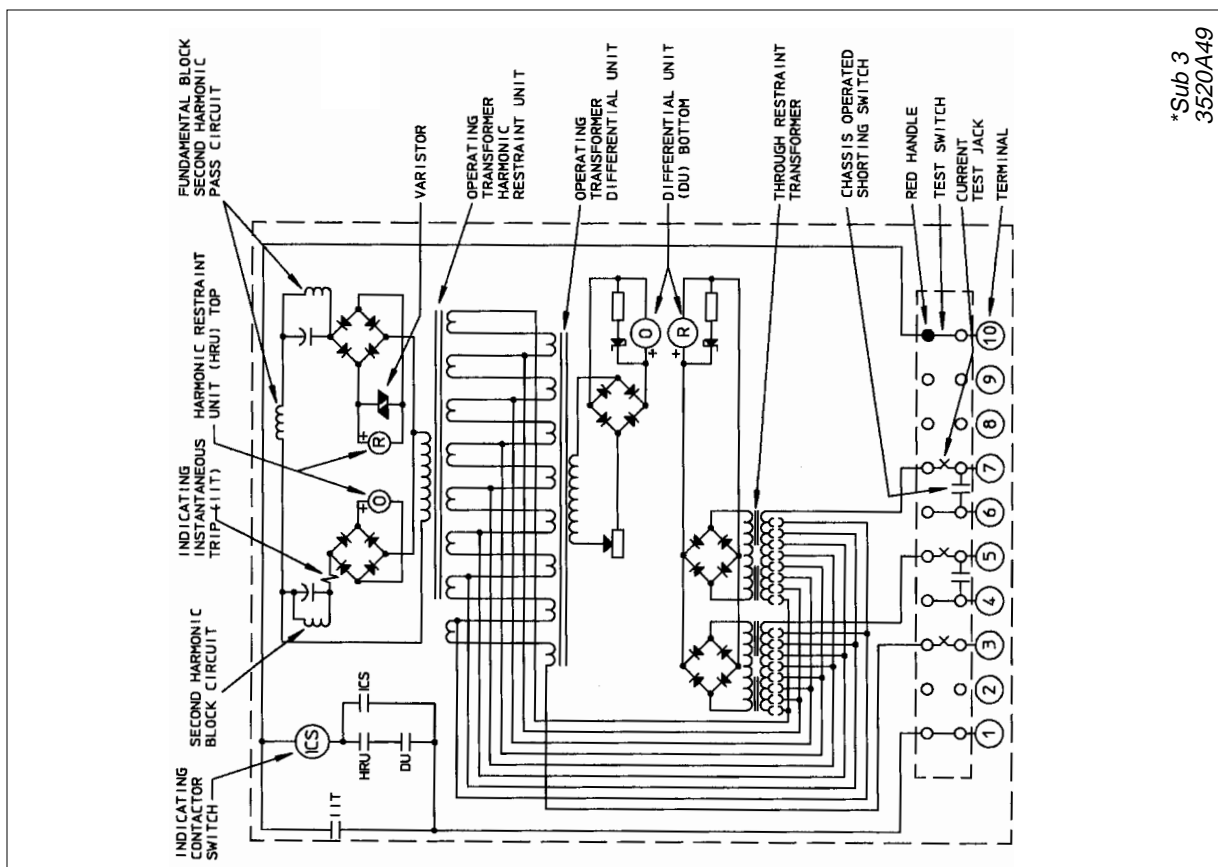

Figure 3. Internal Schematic of the Type HU Relay in FT-31 Case.

* Denotes Change since previous issue

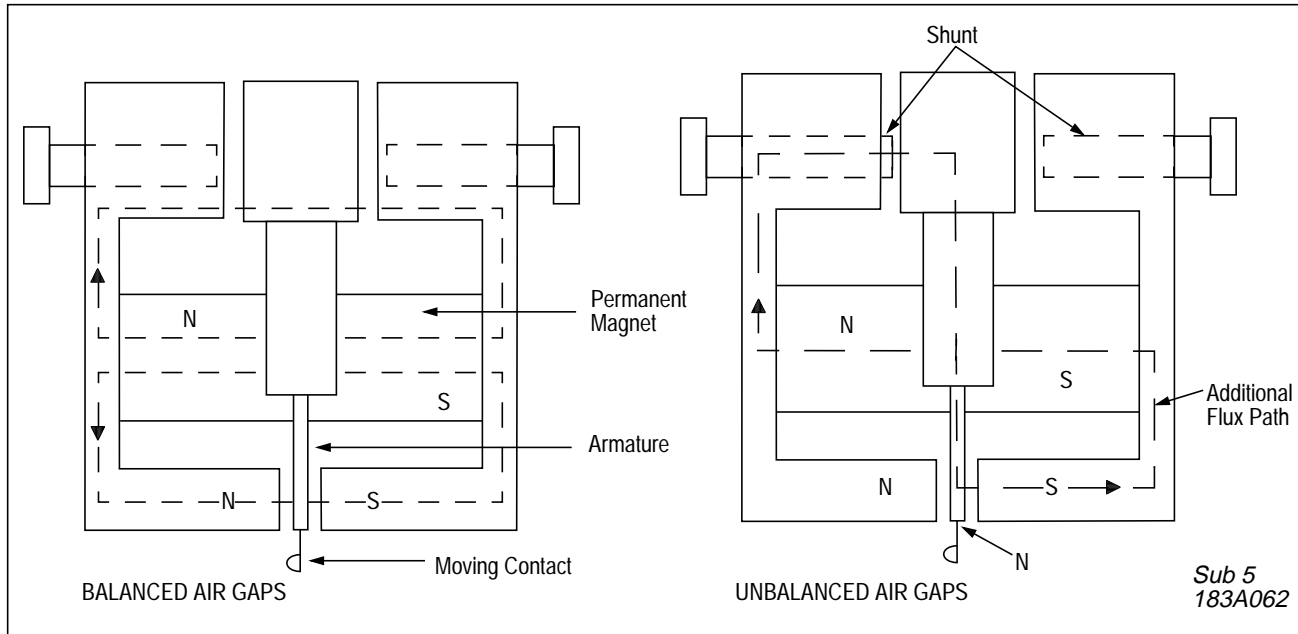

Figure 5. Polar Unit Permanent Magnet Flux Paths

DIFFERENTIAL UNIT (DU)

The differential unit of the HU relay consists of two air-gap restraint transformers, three full-wave rectifiers, saturating operating-transformer, and a dc polar unit.

The HU-1 relay, in addition to the above components, has a third air-gap restraint transformer, an a fourth full-wave rectifier.

Each of the restraint transformers and the operating transformer are provided with taps to compensate for mismatch of line current transformers. These taps are incorporated in the relay in such a manner that changing a tap on a restraint transformer automatically changes the same tap on the operating transformer.

HARMONIC-RESTRAINT UNIT (HRU)

The harmonic restraint unit of the HU and HU-1 relays consists of an air-gap operating transformer, a second harmonic block filter, a fundamental block-second harmonic pass filter, two full-wave rectifiers, indicating instantaneous trip unit, varistor, and a dc polar unit.

Taps are also incorporated in this unit to compensate for mismatch of the line current transformers. Changing a tap on the restraint transformer of the differential unit also changes the tap of this unit.

POLAR UNIT

The polar unit consists of a rectangular shaped magnetic frame, an electromagnet, a permanent magnet, and an armature. The poles of the crescent shaped permanent magnet, bridge the magnet frame. The magnetic frame consists of three pieces joined in the rear with two brass rods and silver solder. These non-magnetic joints represent air-gaps, which are bridged by two adjustable magnetic shunts. The windings are wound around a magnetic core. The armature is fastened to this core and is free to move in the front air-gap. The moving contact is connected to the free end of a leaf spring, which, in turn, is fastened to the armature.

INDICATING CONTACTOR SWITCH UNIT (ICS)

The dc indicating contactor switch is a small clapper-type device. A magnetic armature, to which leaf-spring mounted contacts are attached, is attracted to the magnetic core upon energization of the switch. When the switch closes, the moving contacts bridge two stationary contacts, completing the trip circuit. Also, during this operation, two fingers on the armature deflect a spring located on the front of the switch, which allows the operation indicator target to drop.

The front spring, in addition to holding the target, provides restraint for the armature and thus controls the

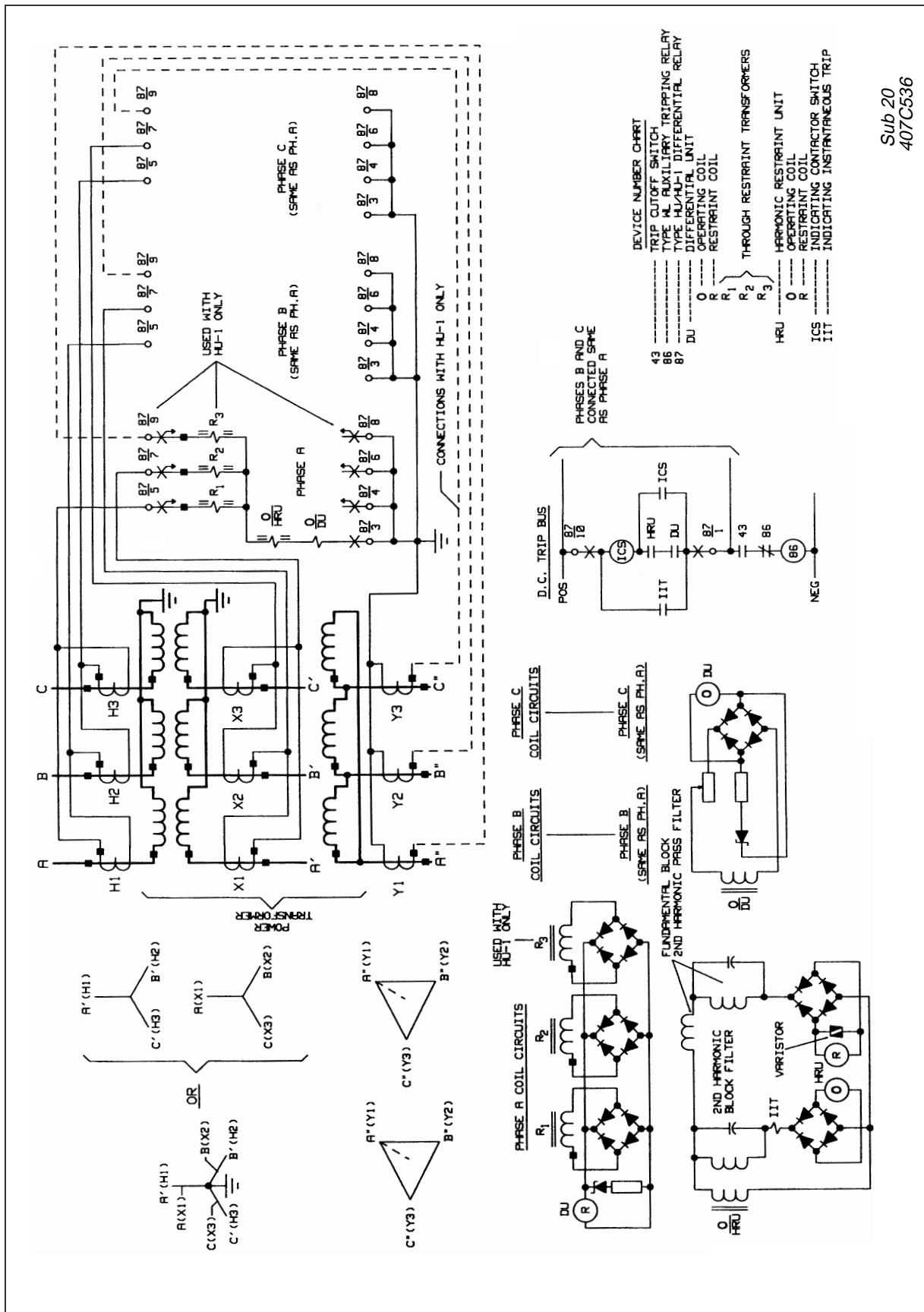

Figure 6. External Schematic of the Type HU and HU-1 Relays.

pick-up value of the switch.

INDICATING INSTANTANEOUS TRIP UNIT (IIT)

The instantaneous trip unit is a small ac operated clapper-type device. A magnetic armature, to which leaf-spring mounted contacts are attached, is attracted to the magnetic core upon energization of the switch. When the switch closes, the moving contacts bridge two stationary contacts completing the trip circuit. Also, during the operation, two fingers on the armature deflect a spring located on the front of the switch which allows the operation indicator target to drop.

A core screw accessible from the top of the switch is used to adjust for pickup.

■ OPERATION

The types HU and HU-1 are connected to the protected transformer as shown in figure 4. In such a connection, the relays operate to protect the transformer for faults internal to the differential zone of the transformer, but not for faults external to the zone. Neither do the relays operate on magnetizing inrush currents associated with energization of the transformer, even though these currents may appear as an internal fault. To avoid these false operations, each unit of the relay performs a separate function. The differential unit (DU) prevents operation on external faults, while the harmonic-restraint unit (HRU) prevent operations on magnetizing inrush currents. Hence, the operation of the relay can best be described under the headings of external fault current, internal fault currents, and magnetizing inrush currents.

EXTERNAL FAULT CURRENTS

The types HU and HU-1 relays have a variable percentage characteristic. This means that the operating current required to close the contact of the differential unit expressed in percent of restraint current varies with the magnitude of the larger restraint current. Figure 7 and figure 8 illustrate this characteristic. To use these curves, divide each restraint current by the appropriate tap and enter the horizontal axis using the larger or largest restraint multiple. Then enter the vertical axis, using the difference of the restraint multiples.

With the relay connected as shown in the schematic

diagram of figure 9a, an external fault causes currents to flow in the air-gap restraint transformers of the differential unit. If the line current transformers do not saturate and the correct ratio matching taps applied, no effective current flows in the operating transformer of the relay. Hence, only a contact-opening torque is produced on the differential unit.

On heavy external faults where a main current transformer saturates, current flows in the operating circuit of the relay. With such a condition, the harmonic-restraint unit may or may not close its contacts, depending upon the harmonics present in the false operating current. However, operation of the relay is prevented by the variable percentage characteristic of the differential unit, since a large differential current is required to close its contacts during heavy external faults.

INTERNAL FAULTS

In the case of an internal fault as shown in figure 9b, the restraint of the differential unit is proportional to the largest restraint current flowing. The sum of the two restraint currents flows into the operating transformer and produces an excess of operating torque, and the differential unit operates.

In the case of an internal fault fed from one source only, the fault current flows in one restraint transformer and the operating transformer. An excess of operating torque is produced on the differential unit and it operates.

Faults normally appear as an offset sine wave with a decaying dc component, and contain very few harmonics. As a result, the harmonic-restraint unit will operate during internal faults to permit the tripping of the relay.

For heavy internal faults, the indicating instantaneous trip unit (IIT) will operate. Since this unit is connected to an air-gap transformer, essentially only the sine wave component of an internal fault is applied to the IIT unit. The dc component of the fault is bypassed by the transformer primary. For example, an internal fault with a first peak of 28 times tap value (includes fifty percent dc) is reduced to a first peak of approximately 14 times tap value (dc component absent) on the secondary transformer. The IIT unit will just operate on this wave since it is set to pick up at a peak current of 14.1 times tap (rms pick-up value = 10 times tap).

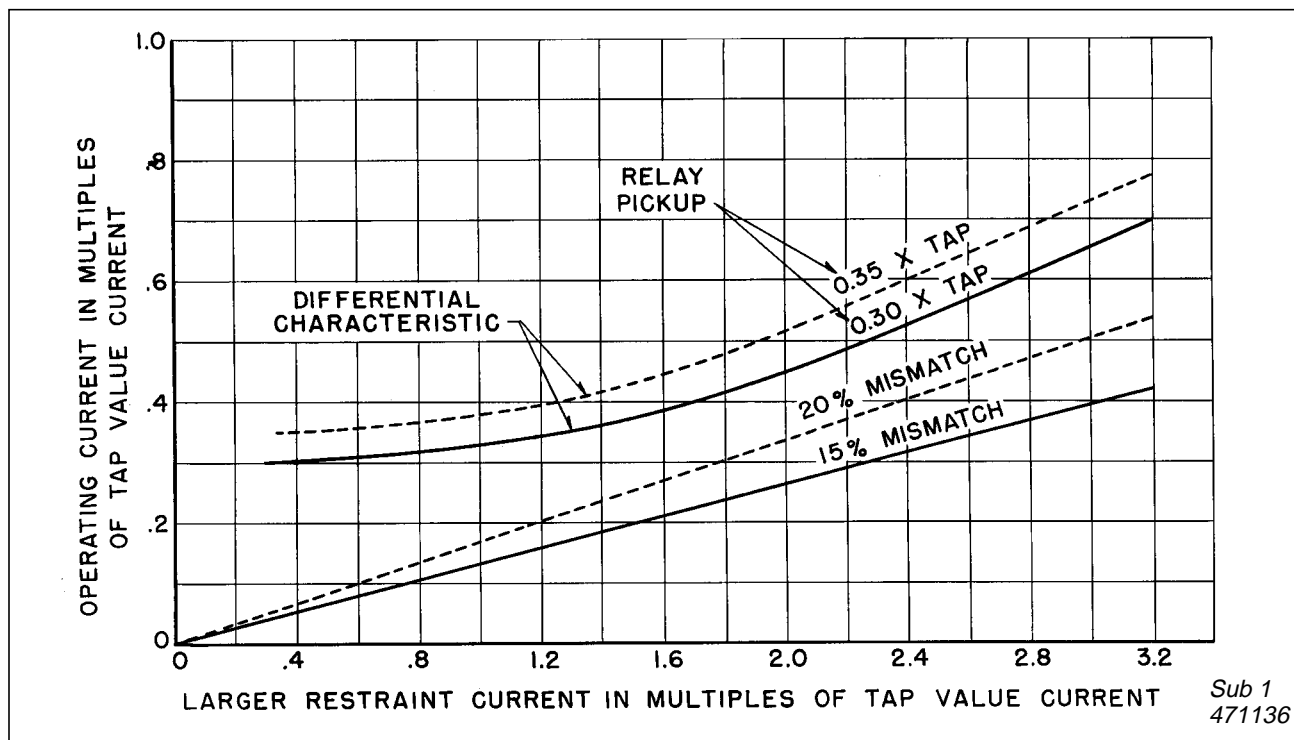

Figure 7. Differential Characteristic of the DU Unit of the HU and HU-1 Relays at **smaller values** of current. Operating Current Shown for 15 and 20% Mismatch.

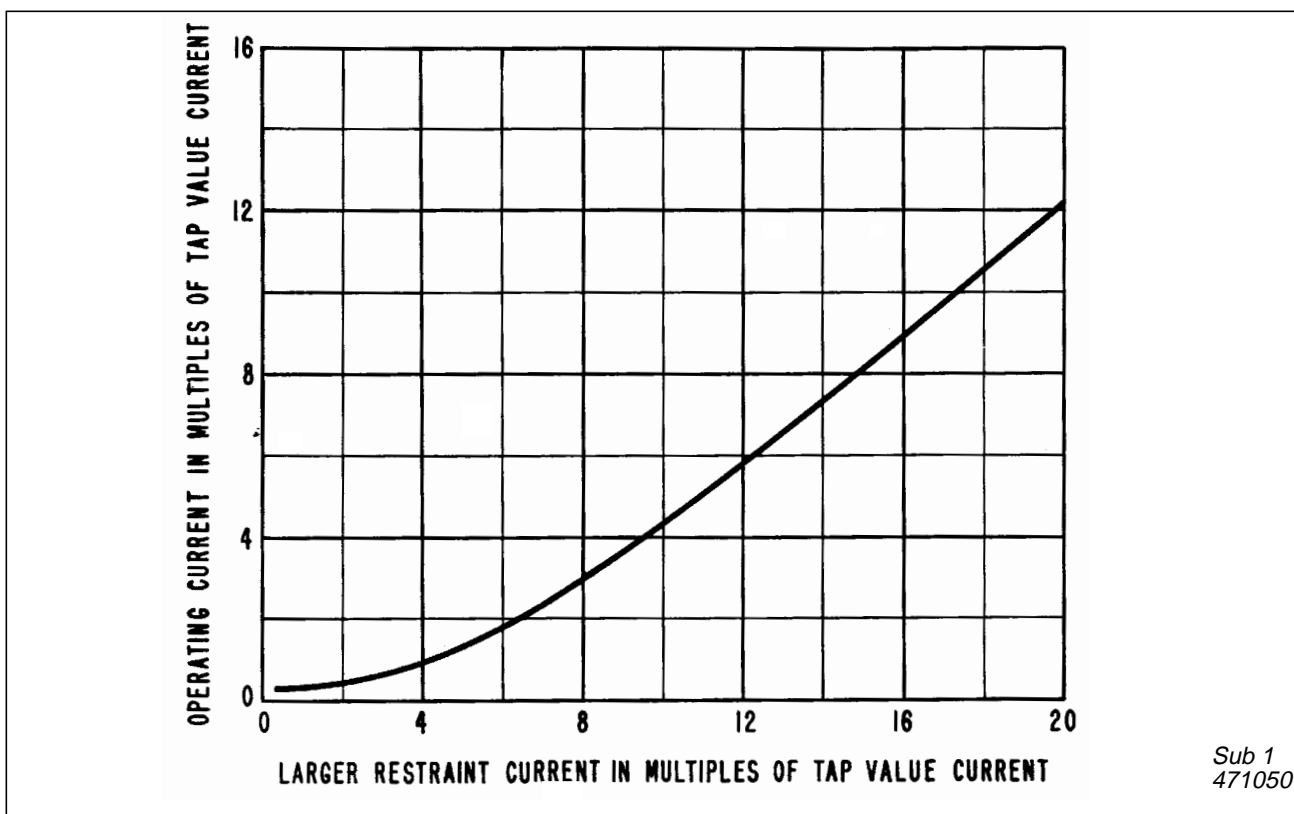

Figure 8. Differential Characteristic of the Differential Unit (DU) of the HU and HU-1 Relays at **larger values** of current.

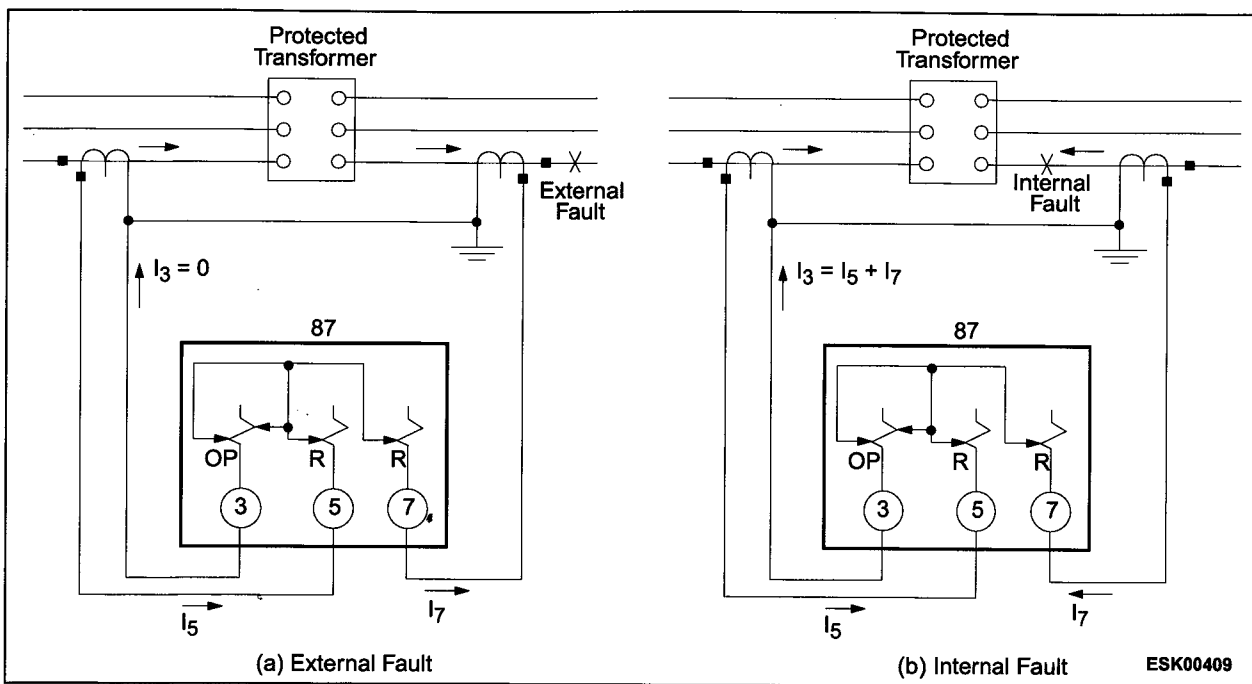

Figure 9. Simplified Schematic of the Type HU Relay with Current Distribution for (a) External Fault (b) Internal Fault.

The varistor connected across the dc side of the restraint rectifier of the harmonic restraint unit prevents excessive voltage peaks from appearing across the rectifiers. These peaks arise through transformer action of the harmonic-restraint polar-unit coils during heavy internal faults. The varistor has a large value of resistance for low voltages, while presenting a low value of resistance for high voltages. This characteristic effectively reduces the voltage spikes on heavy internal faults while not hampering performance during inrush, where the voltage is considerably lower.

MAGNETIZING INRUSH CURRENTS

Magnetizing inrush current waves have various wave shapes. A typical wave appears as a rectified half wave with decaying peaks. In any case, the various wave shapes are rich in harmonics with the second harmonic predominant. Since the second harmonic is always present in inrush waves and not in internal fault waves, this harmonic is used to restrain the harmonic-restraint unit during inrushes. The differential unit may or may not close its contact, depending on the magnitude of the inrush.

When a magnetizing inrush wave is applied to the relay, the dc component of the wave is bypassed by the air-gap operating transformer. The other compo-

nents are fed into the filter circuits. The impedance characteristics of these filters are such that the second harmonic component flows into the restraint coil of the polar unit, while the other harmonics flow into the operating coil. The polar unit will not close its contacts unless the second harmonic content is less than 15 percent of the fundamental component.

The indicating instantaneous trip unit (IIT) will not operate on inrush. The air-gap transformer will bypass the dc component of the inrush thereby reducing the magnitude of the wave applied to the IIT unit. If the inrush has an initial peak of 16 times tap value current, the air-gap transformer will reduce this peak to approximately 8 times tap value on the secondary of the transformer. Since the IIT unit is set for a peak value of 14.1 times tap (rms Pick-up value = 10 times tap), it will not operate on this inrush.

BREAKER MAINTENANCE

Before some of the ct's are bypassed for breaker maintenance the trip circuit, shown in figure 6, should be opened. Otherwise the false-unbalanced current will cause the relay to trip. It is not necessary to short-circuit the relay operating circuit since it has an adequate continuous-current rating. (See "Energy Requirements".)

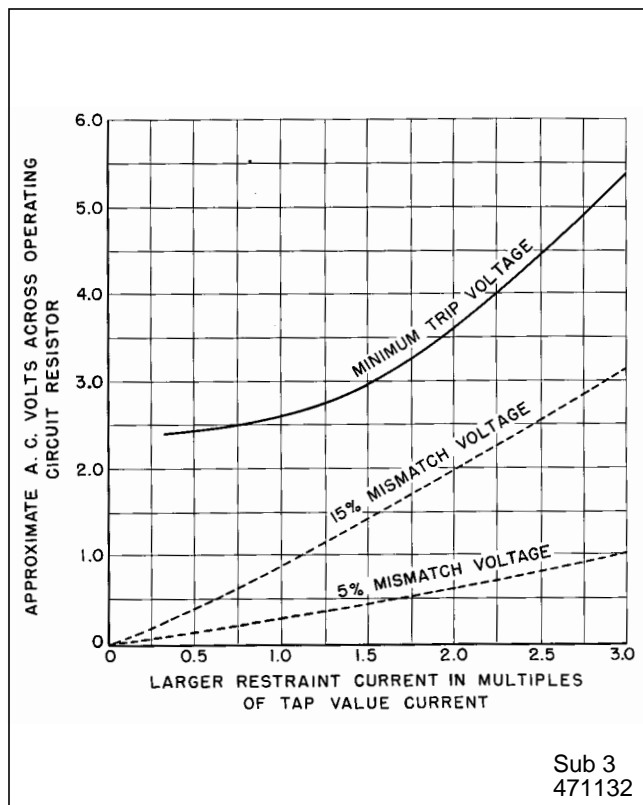

Figure 10. Differential Voltage Characteristic of the DU Unit of the HU and HU-1 Relays with a pickup of 0.30 times tap.

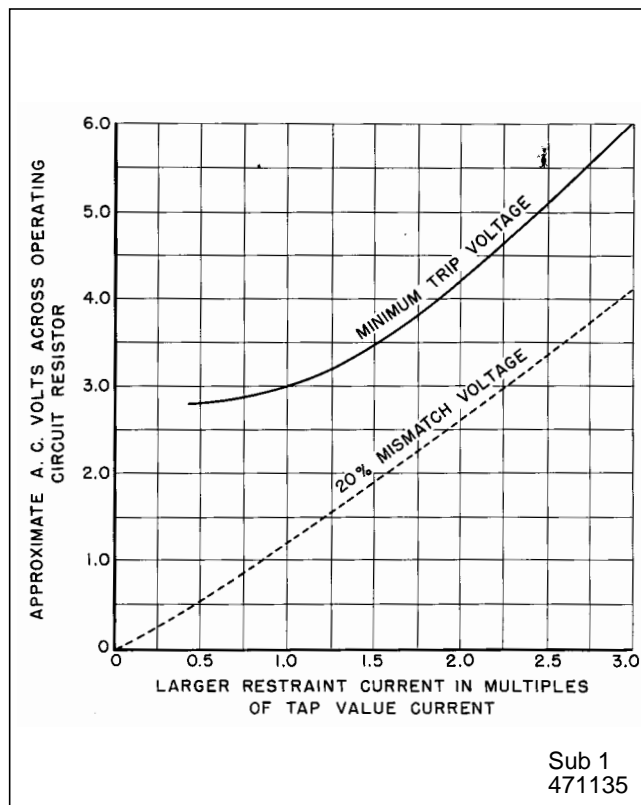

Figure 11. Differential voltage Characteristic of the DU Unit of the HU and HU-1 Relays with a pickup of 0.35 times tap.

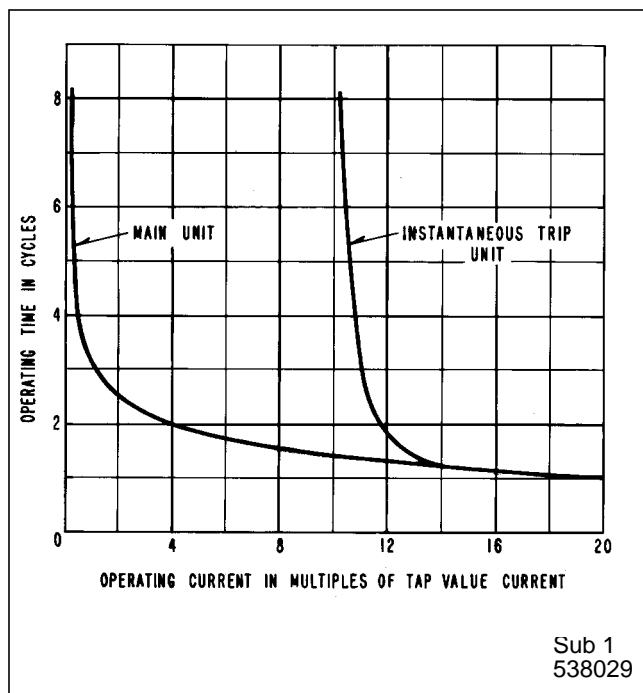

Figure 12. Typical Tripping Time Characteristic.

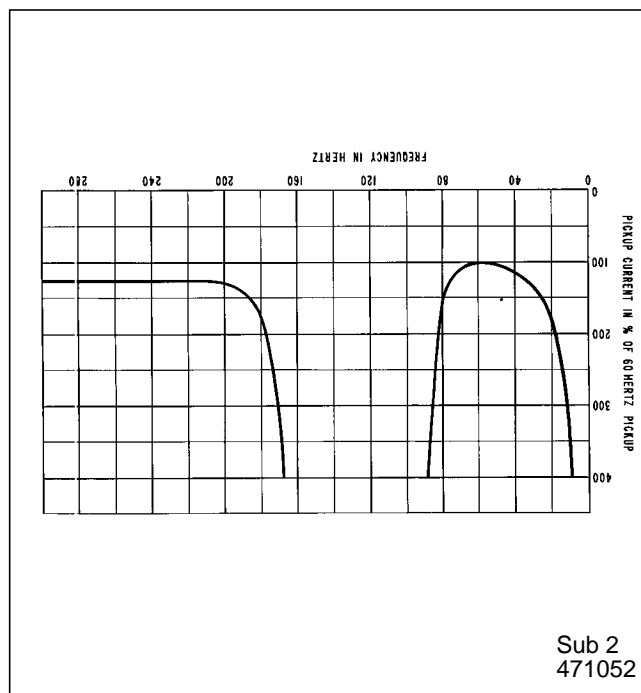

Figure 13. Typical Frequency Response of the HU and HU-1 60 hertz relays.

■ CHARACTERISTICS

Taps are incorporated in the HU and HU-1 relays to compensate for main current transformer mismatch. These taps are as follows: 2.9, 3.2, 3.5, 3.8, 4.2, 4.6, 5.0, 8.7.

To measure the effective unbalance, a sensitive low-reading voltmeter (5000 ohms per volts) can temporarily be connected across the operating coil resistor (at top of case). With a perfect balance the voltmeter reading will be zero. The reading should not exceed the values indicated by the 15% mismatch curve in figure 10 when the relay pickup is 0.30 times tap. If the amount of mismatch is measured or calculated, the measured voltage can be checked against the interpolated value from the curve. For example, assume that the larger restraint current is measured at 1.5 tap multiple and the calculated mismatch is 7%. Then, from figure 10 the measured voltage should be approximately 1.0 volts. Use figure 11 if the pickup is 0.35 times tap.

Pickup of the harmonic-restraint unit and the differential unit is either 30% or 35% of tap value current. Pickup of the indicating instantaneous trip unit is ten times tap value current.

Components of the harmonic-restraint unit are selected such that 15% second harmonic will prevent operation of the unit. This factor is adequate to prevent false operation on inrushes.

The frequency response of the HU and HU-1 relays is shown in figures 13 and 14.

The indicating instantaneous trip contacts will close 30 amperes at 250 volts dc and will carry this current long enough to trip a breaker.

TRIP CIRCUIT

The main contacts will safely close 30 amperes at 250 volts dc, and the seal-in contacts of the indicating contactor switch will safely carry this current long enough to trip a circuit breaker.

Trip Circuit Constants

Indicating Contactor Switch Coil	
Ampere Pickup	Ohms dc Resistance
0.2	8.5
1.0	0.37
2.0	0.10

■ SETTING



Since the tap block screw carries operating current, be sure that the screws are turned tight.

In order to avoid opening current transformer circuits when changing taps under load, the relay must first be removed from the case. Chassis operating shorting switches on the case will short the secondary of the current transformer. The taps should then be changed with the relay outside of the case and then reinserted into the case.

To set the relay, calculations must be performed as shown under "Setting Calculations". After the correct tap is determined, connections can be made to the relay transformers by placing the connector screws in the various terminal-plate holes in front of the relay. Only one tap screw should be inserted in any horizontal row of taps.

INDICATING CONTACTOR SWITCH (ICS)

There are no settings to make on the indicating contactor switch (ICS).

INDICATING INSTANTANEOUS TRIP (IIT)

No settings is required on the indicating instantaneous trip unit. This unit is set at the factory to pickup at 10 times tap value current.

■ SETTING CALCULATIONS

Select the ratio matching taps. There are no other settings. In order to calculate the required tap settings and check current transformer performance the following information is required.

Required Information:

1. Maximum transformer power rating (KVA)_M
2. Maximum external fault currents
3. Line-to-Line voltage ratings of power transformer (V_H, V_I, V_L)
4. Current transformer ratios, full tap (N_T)
5. Current transformer "C" accuracy class voltage,

(or excitation or ratio correction factor curve)

6. One way current transformer lead resistance at 25°C (RL) (when using excitation curve, include ct winding resistance)
7. Current transformer connections (Wye or delta)
8. ct secondary winding resistance, R_S

Definitions of Terms:

- I_P = Primary current at (KVA)_M
- I_R = Relay input current at (KVA)_M
 I_{RH} , I_{RL} , I_{RI} are same as I_R except for high, low and intermediate voltage sides respectively
- I_S = ct secondary current at (KVA)_M
- T = Relay tap setting
 T_H , T_L , T_I = are same as T except for high, low and intermediate voltage windings, respectively
- N = Number of current transformer turns that are in use
- N_P = N/N_T (Proportion of total turns in use)
- N_T = Current transformer ratio, full tap
- V_{CL} = "C" accuracy class voltage
- Z_A = Burden impedance of any devices other than the HU or HU-1 relays, with maximum external fault current flowing
- I_{ext} = Maximum symmetrical external fault current in secondary RMS amperes
- Z_T = Total secondary burden in ohms (excluding current transformer winding resistance)

CALCULATION PROCEDURE

1. *Select current transformer taps*, where multi-ratio types are used. Select a tap to give approximately 5 amperes at maximum load. This will provide good sensitivity and will produce no thermal problem to the ct, the leads, or the relay. Better sensitivity can be achieved by selecting a tap to give more than 5 amperes if a careful check is made of the ct, the leads, and the relay capability. For determining the required continuous rating of the relay, use the expected two-hour

maximum load, since the relay reaches final temperature in this time.

2. *Calculate the relay currents, I_R* . All relay currents for relay tap selection should be based on the same KVA capacity.
 3. *Calculate the relay current ratio(s)* using the lowest current as reference.
 4. Select the tap ratio as close as possible to relay current ratio from table 1. Choose the first relay tap ratio using the largest current ratio from step 3. The other tap ratios should be determined using the lower tap from the first tap ratio as reference.
- I_R should not exceed relay continuous rating as defined in **Energy Requirement Table**.
5. *Check IIT operation*. The IIT pickup is ten times the relay tap value for the HU and HU-1. Therefore, the maximum symmetrical error current which is flowing in the differential circuit on external fault current due to dissimilar ct saturation should not exceed 10 times relay tap.

6. Determine Mismatch.

For 2 winding banks:

$$\% \text{ mismatch} = 100 \frac{(I_{RL}/I_{RH}) - (T_L/T_H)}{S} \quad (1)$$

Where S is the smaller of the two terms, (I_{RL}/I_{RH}) or (T_L/T_H)

For 3 winding banks:

Repeat calculation of equation (1) and apply similar equations to calculate mismatch from the intermediate to high and from the intermediate to low voltage windings.

Where tap changing under load is performed the relay should be set on the basis of the middle or neutral tap position. The total mismatch, including the automatic tap change should not exceed 15% with a 30% sensitivity relay, and 20% with a 35% sensitivity relay. Note from figure 7 that an ample safety margin exists at these levels of mismatch.

7. Check current transformer performance. Ratio error should not exceed 10% with maximum symmetrical external fault current flowing. An accurate method of determining ratio error is to use ratio-correction-factor curves (RCF). A less accurate, but satisfactory method is to utilize the ANSI relaying accuracy classification. If the "C" accuracy is used, performance will be adequate if:

$$\frac{[N_P V_{C1} - (I_{ext} - 100) R_S]}{I_{ext}} \text{ is greater than } Z_T \quad (2)$$

NOTE: Let $I_{ext} = 100$ where maximum external fault current is less than 100A.

For Wye-connected ct:

$$\begin{aligned} Z_T &= \text{lead resistance} + \text{relay burden} + Z_A \\ &= 1.13 R_L + \frac{0.15}{T} + Z_A \text{ ohms} \end{aligned} \quad (3)$$

(R_L multiplier, 1.13, is used to account for temperature rise during faults. $0.15/T$ is an approximation. Use 2-way lead resistance for single phase-to-ground fault.)

For delta-connected ct:

$$\begin{aligned} Z_T &= 3 \left(1.13 R_L + \frac{0.15}{T} + Z_A \right) \text{ ohms} \\ &= 3.4 R_L + \frac{0.45}{T} + 3Z_A \end{aligned} \quad (4)$$

8. Examples:

Refer to figure 15 for setting examples.

**Table 1:
HU Relay Tap Ratios**

	2.9	3.2	3.5	3.8	4.2	4.6	5.0	8.7
2.9	1.000	1.103	1.207	1.310	1.448	1.586	1.724	3.000
3.2		1.000	1.094	1.188	1.313	1.438	1.653	2.719
3.5			1.000	1.086	1.200	1.314	1.429	2.486
3.8				1.000	1.105	1.211	1.316	2.289
4.2					1.000	1.095	1.190	2.071
4.6						1.000	1.087	1.890
5.0							1.000	1.740
8.7								1.000

INSTALLATION

The relays should be mounted on switchboard panels or their equivalent in a location free from dirt,

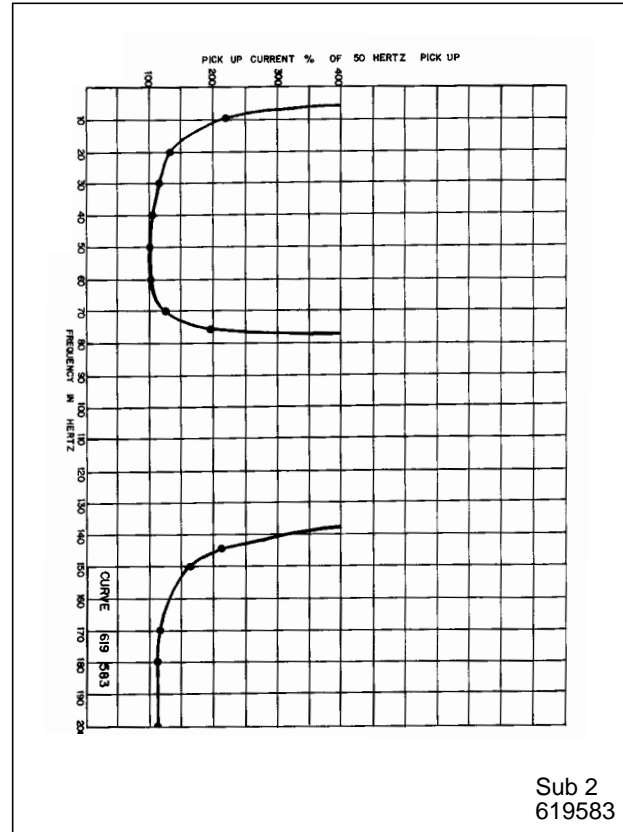

Figure 14. Typical Response of the HU and HU-1 50 Hertz Relays.

moisture, excessive vibration and heat. Mount the relay vertically by means of the four mounting holes on the flange. The mounting screws may be utilized for grounding the relay. External toothed washers are provided for use in the locations shown on the outline and drilling plan to facilitate making a good electrical connection between the relay case. Ground wires should be affixed to the mounting screws as required for poorly grounded or insulating panels. Other electrical connections may be made directly to the terminals by means of screws for steel panel mounting.

For detail information on the FT case refer to I.L. 41-076 semi-flush mounting.

ADJUSTMENTS AND MAINTENANCE

The proper adjustments to insure correct operation of this relay have been made at the factory and should not be disturbed after receipt by the customer.

PERFORMANCE TESTS

The following check is recommended to verify that

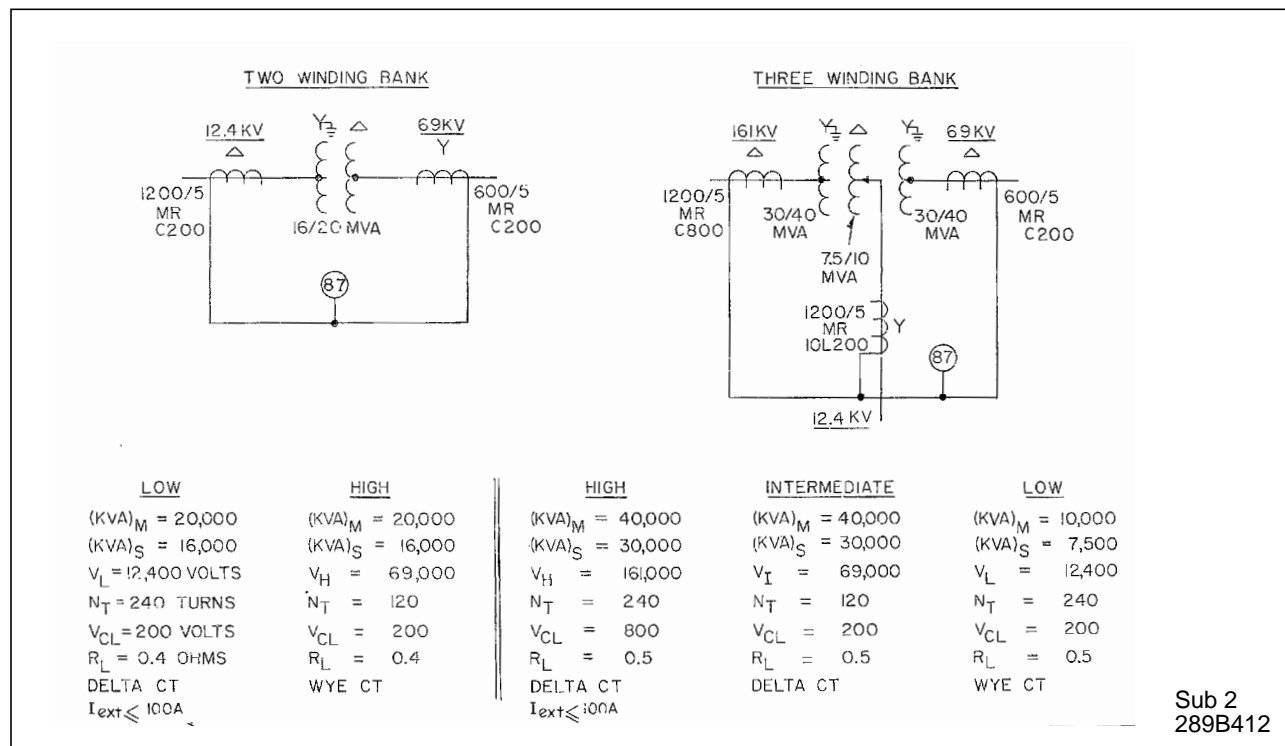

Figure 15. Example for Setting Calculations

the relay is in proper working order. All checks can best be performed by connecting the relay per the test circuit of figure 16. **RELAY MUST BE TESTED IN CASE.**

1. Minimum Trip Current

NOTE: The moving contact of the upper polar unit (HRU) closes to the left-hand (front view) stationary contact. The moving contact of the lower polar unit (DU) closes to the right-hand (front view) stationary contact.

With SPDT switch open and SPST switch closed and relay set on 5-ampere tap, apply 1.35 to 1.65 amperes for the 30% sensitivity relay and 1.6 to 1.9 amperes for the 35% sensitivity relay. Relay should operate. The upper polar unit may operate for lower currents, but not below 1.0 ampere. This low pickup will not impair its operation on magnetizing inrush currents and should not be disturbed if it is found to be less than the lower polar unit. If the pickup value is considered to be too low, it should be checked after applying a polarizing current magnitude of 20 times tap value to relay terminals 3 and 7. This will cause the upper polar unit to pickup at a current of approximately 1.65 amperes.

2. Indicating Instantaneous Trip Pickup

With switch open and relay set on 5 ampere tap, apply 50 amperes to relay. Indicating instantaneous trip should pickup and its target should drop freely.

The contact gap should be approximately 0.094 inches between the bridging moving contact and the adjustable stationary contacts. The bridging moving contact should touch both stationary contacts simultaneously.

3. Indicating Contactor Switch

Block the polar unit contacts closed and pass sufficient dc current through the trip circuit to close the contacts of the ICS. This value of current should not be greater than the particular ICS nameplate rating. The indicator target should drop freely.

Repeat above except for 85% of the ICS nameplate rating current. Contacts should not pickup and target should not drop.

TWO-WINDING TRANSFORMER CALCULATIONS

See figure 15

	LOW	HIGH
1. <u>Select ct Ratio:</u>		
	$\frac{200,000}{12.4\sqrt{3}} = 930 \text{ amp.}$	$\frac{20,000}{69\sqrt{3}} = 167 \text{ amp.}$
$I_P = \frac{(KVA)_M}{\frac{V\sqrt{3}}{1000}} =$	1000/5 (N = 200)	500/5 (N = 40)
Select Ratio		
	$\frac{930}{200} = 4.65 \text{ amp.}$	$\frac{167}{40} = 4.18 \text{ amp.}$
2. <u>Select Relay Taps:</u>		
$I_S = \frac{I_P}{N} =$	$I_{RL} = 4.65\sqrt{3} = 8.05 \text{ amp.}$	$I_{RH} = 4.18 \text{ amp.}$
$I_R =$	$T_L = 8.7$	$T_H = \frac{4.18}{8.05} \times 8.7 = 4.64$
Select Tap		$T_H = 4.6$
Desired Tap		
3. <u>Determine Mismatch:</u>		
% Mismatch =		
$100 \frac{(I_{RL}/I_{RH}) - (T_L/T_H)}{T_L/T_H} =$		$100 \frac{(8.05/4.18) - (8.7/4.6)}{8.7/4.6} =$
		$100 \frac{1.92 - 1.89}{1.89} =$
		1.6%
4. <u>Check ct Performance:</u>		
$Z_T =$	$3.4 R_L + \frac{0.45}{T} =$	$1.13 R_L + \frac{0.15}{T} =$
	$3.4 \times 0.4 + \frac{0.45}{8.7} = 1.36 + 0.05 =$	$1.13 \times 0.4 + \frac{0.15}{4.6} + 0.03$
	<u>1.41 ohms</u>	<u>0.48 ohms</u>
$N_P = \frac{N}{N_T} =$	$\frac{200}{240} = 0.833$	$\frac{40}{120} = 0.333$
$\frac{N_P V_{CL}}{100} =$	$\frac{0.833 \times 200}{100} = 1.67$	$\frac{0.333 \times 200}{100} = 0.67$
$(N_P V_{CL}/100) > Z_T$	Yes	Yes

THREE-WINDING TRANSFORMER CALCULATIONS

See figure 15

	HIGH	INTERMEDIATE	LOW
1. <u>Select ct Ratio:</u>			
$I_P = \frac{(KVA)_M}{\frac{V\sqrt{3}}{1000}} =$	$\frac{40,000}{161\sqrt{3}} = 143 \text{ amp}$	$\frac{40,000}{69\sqrt{3}} = 334 \text{ amp}$	$\frac{10,000}{12.4\sqrt{3}} = 465 \text{ amp}$
Select Ratio	400/5 (N= 80)	600/5 (N = 120)	1000/5 (N = 200)
2. <u>Select Relay Taps:</u>			
$I_S = \frac{I_P}{N} =$	$\frac{143}{80} = 1.78 \text{ amp}$	$\frac{334}{120} = 2.78 \text{ amp}$	$\frac{465}{200} = 2.32 \text{ amp at 10 MVA}$
$I_R(\text{at 40 MVA}) =$	$I_{RH} = 1.78\sqrt{3}$ $= 3.08 \text{ amp}$	$I_{RI} = 2.78\sqrt{3}$ $= 4.82 \text{ amp}$	$I_{RL} = \frac{40}{10} \times 2.32$ $= 9.3 \text{ amp}$
Select Tap			$T_L = 8.7$
Desired Tap	$T_H = 8.7 \frac{3.08}{9.30}$ $= 2.88$	$T_I = 8.7 \frac{4.82}{9.30}$ $= 4.52$	
Select Tap	$T_H = 2.9$	$T_I = 4.6$	
3. <u>Determine Mismatch:</u>			
% Mismatch =	$100 \frac{(I_{RH}/I_{RH}) - (T_H/T_I)}{T_H/T_I} =$ $100 \frac{(3.08/4.82) - (2.9/4.6)}{2.9/4.6} =$ $100 \frac{0.640 - 0.630}{0.630} =$ <u>1.6%</u>	$100 \frac{(I_{RI}/I_{RL}) - (T_I/T_L)}{I_{RI}/I_{RL}} =$ $100 \frac{(4.82/9.30) - (4.6/8.7)}{4.82/9.30} =$ $100 \frac{0.518 - 0.528}{0.518} =$ <u>-1.9%</u>	$100 \frac{(I_{RL}/I_{RH}) - (T_L/T_H)}{T_L/T_H} =$ $100 \frac{(9.3/3.08) - (8.7/2.9)}{8.7/2.9} =$ $100 \frac{3.02 - 3.00}{3.00} =$ <u>0.67%</u>
4. <u>Check ct Performance</u>			
$Z_T =$	$3.4 R_L + \frac{0.45}{T} =$ $3.4 \times 0.5 + \frac{0.45}{2.9} =$ $1.70 + 0.16 =$ <u>1.86 ohms</u>	$3.4 R_L + \frac{0.45}{T} =$ $3.4 \times 0.5 + \frac{0.45}{4.6} =$ $1.70 + 0.10 =$ <u>1.80 ohms</u>	$1.13 R_L + \frac{0.15}{T} =$ $1.13 \times 0.5 + \frac{0.15}{8.7} =$ $0.565 + 0.02 =$ <u>0.58 ohms</u>
$N_P = \frac{N}{N_T} =$	$\frac{80}{240} = 0.333$	$\frac{120}{120} = 1.0$	$\frac{200}{240} = 0.833$
$\frac{(N_P V_{CL})}{100}$	$\frac{800 \times 0.333}{100} = 2.67$	$\frac{200 \times 1.0}{100} = 2.0$	$\frac{200 \times 0.833}{100} = 1.67$
$((N_P V_{CL})/100) > Z_T$	YES	YES	YES

4. Differential Characteristic

- a. Close SPDT switch to position 1. Close SPST switch and set I_{ac} to zero and I_{SR} to 30 amps. Then adjust I_{ac} to 20 amperes. Lower I_{SR} and the relay should operate between the following limits:

$$I_{ac} = 20 \text{ amperes}$$

$$I_{LR} = 45 \text{ to } 50 \text{ amperes}$$

30% Sensitivity Relay Only

- b. Close SPDT switch to position 1 with SPST switch closed. Set I_{ac} to zero and adjust I_{SR} to 10 amperes. Increase I_{ac} to 2.8 amperes. If the lower polar unit does not operate with $I_{ac} = 2.8$ amperes and $I_{LR} = 12.8$ amperes, lower I_{SR} current. The lower polar unit should operate between the following limits:

$$I_{ac} = 2.8 \text{ to } 2.95 \text{ amperes}$$

$$I_{LR} = 11.8 \text{ to } 12.8 \text{ amperes}$$

- c. Reverse leads to restraint transformers and repeat differential test outlined in paragraph 4b. Results should be approximately the same as obtained under paragraph 4b.

35% Sensitivity Relay Only

- d. Close SPDT switch to position 1 with SPST switch closed. Set I_{ac} to zero and adjust I_{SR} to 9 amperes. Increase I_{ac} to 2.8 amperes. If the lower polar unit does not operate with $I_{ac} = 2.8$ amperes and $I_{LR} = 11.8$ amperes, lower I_{SR} current. The lower polar unit should operate between the following limits:

$$I_{ac} = 2.8 \text{ amperes}$$

$$I_{LR} = 10.8 \text{ to } 11.8 \text{ amperes}$$

- e. Reverse leads to restraint transformers and repeat differential test outlined in paragraph 4d. Results should be approximately the same as obtained under paragraph 4d.

5. Harmonic Restraint Characteristic

Close SPDT switch to position 2 with SPST switch closed. Short out I_{LR} ammeter. Set I_{dc} to 4 amperes and adjust I_{ac} until upper polar unit operates. I_{ac} should read between 6.5 and 9 amperes.

As shown in figure 17, these values of alternating current corresponding to 17 percent and 14 percent second harmonic.

In-Service Test

Table 2 is to be used as an in-service check of the HU or HU-1 relay using any tap combination. This test also checks against reversed tap connections. The relay should be connected as shown in figure 16 with the SPDT switch in position 1. The ammeter I_{SR} measures the smaller restraint current and should be connected to the terminal associated with the tap block of the smaller setting. The ammeter I_{LR} measures the larger restraint current, and should be connected to the terminal associated with the larger tap block setting. Terminal 5 supplies the upper tap block; terminal 7 supplies the second tap block; and terminal 9 (HU-1 only) supplies the lower tap block (refer to figures 3 and 4).

Table 2 gives the values of I_{ac} necessary to operate the relay when using a value of I_{SR} equal to 3 times tap value for all taps except the 8.7 tap. A value of I_{SR} equal to 2 times tap value was given for the 8.7 tap setting in order to keep the current at a convenient value of testing. Table 2 refers to a 30% relay. For a 35% relay, values of I_{ac} will be .1 to .2 amperes higher.

Example (HU Relay):

Upper Tap Block Tap 3.5

Lower Tap Block Tap 5.0

Since the upper tap block has the smaller tap setting I_{SR} should be connected to the upper tap block (Terminal 5), and I_{LR} should be connected to Terminal 7. From table 1 under "Restraint Transformer Tap: Larger" = 5.0 "Smaller" = 3.5, set $I_{SR} = 10.5$ amps. The value of I_{ac} to operate the relay should be between 8.3 and 9.2 amps.

To check the third restraint winding on the HU-1 repeat the above procedure using terminal 9 and either terminal 5 or 7.

■ ROUTINE MAINTENANCE

All relays should be checked at least once every year or at such other time intervals as may be dictated by experience to be suitable to the particular application.

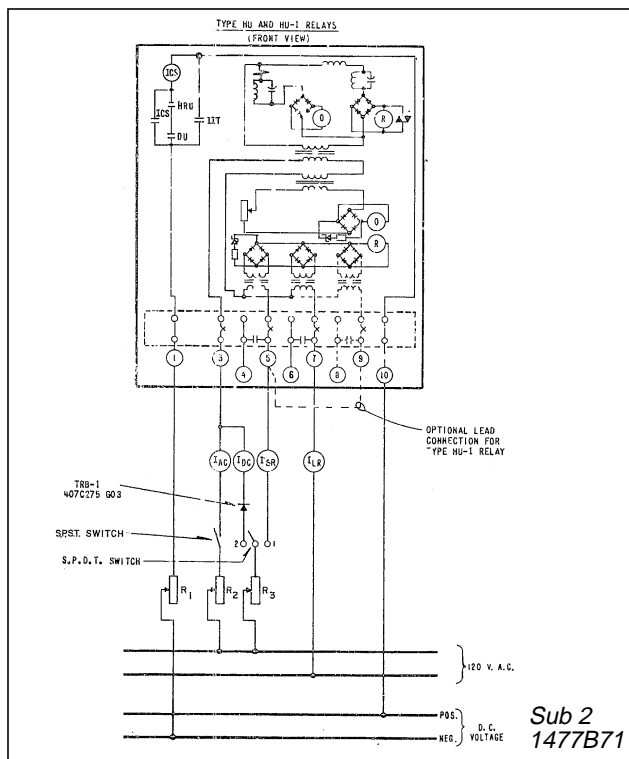

Figure 16. Test Circuit of the HU and HU-1 Relays

All contacts should be periodically cleaned. A contact burnisher Style 182A836H01 is recommended for this purpose. The use of abrasive material for cleaning contacts is not recommended, because of the danger of embedding small particles in the face of the soft silver and thus impairing the contact.

■ CALIBRATION (ALL RELAYS)

Use the following procedure for calibrating the relay if the relay has been taken apart for repairs or the adjustments disturbed. This procedure should not be used until it is apparent that the relay is not in proper working order. **All adjustments to be done with relay inside its case.** (See "Performance Check".)

Polar Units

1. Contacts

NOTE: In adjusting either the stationary contact or backup, the screw in the elongated holes of the assemblies should be loosened, not removed, during the adjustment procedure.

- a. Upper Unit (HRU) - Place a 0.065 to 0.070 inch feeler gage between the right-hand

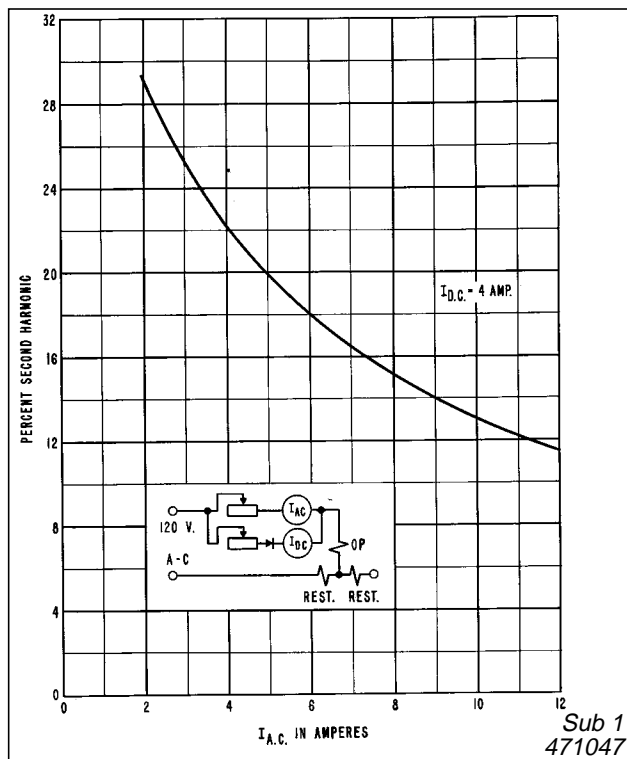

Figure 17. Variation of Second Harmonic Content of Test Current

(front view) pole face and the armature. This gap should be measured near the front of the right-hand pole face. Bring up the right-hand (front view) backstop until it just makes with the moving contact. Tighten the screw in the elongated hole of the backstop and remove gage. Place a 0.046 feeler between the moving contact and the stationary contact on the left-hand (front view) side of the polar unit. Bring up the stationary contact until it just makes with the gage. Tighten mounting screw in the elongated hole of the stationary contact and remove gage.

- b. Lower Unit (DU) - Place a 0.065 to 0.070 inch feeler gage between the left-hand (front view) pole face and the armature. This gap should be measured near the front of the right-hand pole face. Bring up the left-hand (front view) backstop until it just makes with the moving contact. Tighten the screw in the elongated hole of the backstop and remove gage. Place a 0.065 to 0.070 feeler gage between the moving contact and the stationary contact on the

Table 2:

Restraint Transformer Tap	Larger	2.9	3.2	3.5	3.8	4.2	4.6	5.0	8.7
Smaller	Current in Amperes								
2.9	I _{SR}	8.7	8.7	8.7	8.7	8.7	8.7	8.7	5.8
	I _{AC} (Min)	2.6	3.7	5.0	5.8	7.8	9.0	10.4	16.2
	I _{AC} (Max)	2.8	4.0	5.5	6.4	8.6	10.0	11.6	17.9
3.2	I _{SR}		9.6	9.6	9.6	9.6	9.6	9.6	6.4
	I _{AC} (Min)		2.7	4.0	4.9	6.9	8.1	9.6	15.7
	I _{AC} (Max)		3.1	4.4	5.4	7.6	9.0	10.6	17.3
3.5	I _{SR}			10.5	10.5	10.5	10.5	10.5	7.0
	I _{AC} (Min)			3.0	3.8	5.7	6.9	8.3	14.5
	I _{AC} (Max)			3.3	4.2	6.3	7.7	9.2	16.1
3.8	I _{SR}				11.4	11.4	11.4	11.4	7.6
	I _{AC} (Min)				3.2	5.2	6.5	7.9	14.1
	I _{AC} (Max)				3.6	5.7	7.2	8.7	16.0
4.2	I _{SR}					12.6	12.6	12.6	8.4
	I _{AC} (Min)					3.5	4.7	6.2	12.9
	I _{AC} (Max)					3.9	5.2	6.9	14.2
4.6	I _{SR}						13.8	13.8	9.2
	I _{AC} (Min)						3.9	5.3	12.4
	I _{AC} (Max)						4.3	5.9	13.7
5.0	I _{SR}							15.0	10.0
	I _{AC} (Min)							4.3	11.6
	I _{AC} (Max)							4.8	12.9
8.7	I _{SR}								17.4
	I _{AC} (Min)								5.0
	I _{AC} (Max)								5.5

right-hand (front view) side of the polar unit. Bring up the stationary contact until it just makes with the gage. Tighten mounting screw in the elongated hole of the stationary contact and remove gage.

2. Minimum Trip Current

A. Harmonic Restraint Unit (HRU)

1. Polarization Test - Connect the relay per test circuit of figure 16. Close SPDT switch to position 2 and open SPST switch ($I_{ac} = 0$). Pass $I_{dc} = 0.8$ times tap value current (4 amperes dc on 5 ampere tap) into the relay.
2. Pickup and Dropout Adjustment - After unit has been polarized, open SPDT switch ($I_{dc} = 0$) and close SPST switch. Set $I_{ac} = 30\%$ of

tap value current and adjust the right-hand shunt on the upper unit until it operates.

Lower I_{ac} gradually to 15% of tap value current and adjust the left-hand shunt until the unit resets.

Repeat the polarization tests, pickup and dropout tests until the unit performs as follows with no further adjustment of the shunts.

- a. The unit operates between 28% to 30% of tap value current immediately after the application of polarization current of $I_{dc} = 0.8$ times tap value current. The unit will reset at a value of current 15% of tap value current or greater.

- b. After the dropout has been measured, the unit should operate at 25% or higher of tap value current without the polarization test. Pickup value should then remain within this value until the polarization current is applied again.
 - c. Upon polarizing the unit, the unit will operate at a value of current greater than 25% of tap value current but not greater than 31% of tap value current.
3. Pickup - With switch open, pass $I_{ac} = 10$ times tap value current and adjust core of the instantaneous trip unit until it picks up. The target should drop freely.

Harmonic-Restraint Unit (HRU)

Close SPST switch and close SPDT switch to position 2. Short out I_{LR} ammeter. Adjust direct current until I_{dc} reads 0.8 times tap setting. Gradually increase alternating current until upper polar unit operates with I_{ac} reading between 1.3 and 1.8 times tap setting. The percent second harmonic in the wave may be derived by the use of the formula:

$$\% \text{ second harmonic} = \frac{47 I_{dc}}{I_{ac} + 1.11 I_{dc}}$$

This formula is plotted in curve form in figure 17 for $I_{dc} = 4$ amperes.

Percentage Slope Characteristic (DU)

Close SPST switch and close SPDT switch to position 1. Set I_{ac} to zero and I_{SR} to 5.5 times tap value current. Then adjust I_{ac} to 4 times tap value current.

Adjust resistor at top of relay until lower polar unit operates. Interchange lead positions to terminals 5 and 7 and repeat the above test. The lower polar unit should operate between the limits of:

$I_{ac} = 4$ times tap value current

$I_{LR} = 9$ to 10 times tap value current

Trip condition can best be determined by holding I_{ac} at 4 times tap value current and varying I_{LR} by adjusting I_{SR} . If I_{LR} is too low the contacts will be closed when the currents are first applied. Hence, I_{LR} should be increased until the contacts open and then decreased until contacts close.

The adjustment of the resistor will have some effect on the pickup of the unit. Hence, polarize the circuit and recheck the pickup. If necessary readjust shunts to obtain a pickup of 30% of tap value current and dropout of 15% or greater of tap value current. If shunts are changed, check to see that above readings are obtained on the higher restraint currents. If necessary readjust resistor and repeat procedure until the unit operates within the specified limits.

Apply $I_{ac} = .56$ times tap value and vary I_{LR} by adjusting I_{SR} until lower polar unit operates. The lower polar unit should operate between following limits.

B) Differential Unit (DU)

Set the adjustable resistor at top of the relay in the approximate center of its range. Open the SPDT switch and close the SPST switch and pass $I_{ac} = 20$ times tap value polarizing current. This current should be applied for a very short period of time and it should be suddenly interrupted. Adjust right-hand shunt of lower polar unit until it trips with $I_{ac} = 30\%$ of tap value amperes. Lower I_{ac} gradually to 15% of tap value current and adjust right-hand shunt until unit resets. If polar unit resets before 15% of tap value current, no adjustments are necessary to the left-hand shunt. Repeat these steps until the lower polar unit will pickup at 30% of tap value current and reset for values of tap value current greater than 15%.

Indicating Instantaneous Trip (IIT)

Initially adjust unit on the pedestal so that armature fingers do not touch the yoke in the reset position (viewed from top of switch between cover and frame). This can be done by loosening the mounting screw in the molded pedestal and moving the IIT in the downward position.

1. Contact Wipe - Adjust the stationary contacts so that both stationary contacts make with the moving contacts simultaneously and wipe 1/64" to 3/64" when the armature is against the core. This can be accomplished by inserting a 0.0125 thick gage between the armature and core and adjusting the stationary contacts until they just touch the moving contacts.
2. Target - Manually raise the moving contacts and check to see that the target drops at the same time as the contacts make or up to 1/16" ahead. The cover may be removed and the tab holding the target reformed slightly if necessary. **Care should be exercised so that the target will not drop with a slight jar.**

$I_{LR} = 2.36$ to 2.56 times tap value current.

Indicating Contactor Switch (ICS)

Initially adjust unit on the pedestal so that armature fingers do not touch the yoke in the reset position. (Viewed from top of switch between cover and frame.) This can be done by loosening the mounting screw in the molded pedestal and moving the ICS in the downward position.

1. Contact Wipe - Adjust the stationary contact so that both stationary contacts make the moving contacts simultaneously and wipe 1/64" to 3/64" when the armature is against the core.
2. Target - Manually raise the moving contacts and check to see that the target drops at the same time as the contacts make or up to 1/16" ahead. The cover may be removed and the tab holding the target reformed slightly if necessary. However, care should be exercised so that the target will not drop with a slight jar.
3. Pickup - The unit should pickup at 98% of rating and not pickup at 85% of rating. If necessary, the cover leaf springs may be adjusted. To lower the pickup current use a tweezer or similar tool and squeeze each leaf spring approximate equal by applying the tweezer between the leaf spring and the front surface of the cover at the bottom of the lower window. If the pickup is low, the front cover must be removed and the leaf spring bent outward equally.

Calibration (35%-Sensitivity Relays)

The differential unit (DU) should first be calibrated as outlined under "Calibration (All relays)". Next the right-hand shunt of the lower polar unit should be turned out until the relay separates at:

$I_{ac} = .45$ times tap value current

$I_{LR} = 1.64$ times tap value current

This changes the percentage slope curve of the relay to that shown by the 35 percent sensitivity curve of figure 7. Pickup of the relay is increased from 30% to approximately 35% of tap value current and the curve is changed at low values of restraint current to that shown in figure 7. At large values of restraint current the percentage slope characteristic is essentially the same as shown in figure 8.

As shown in figure 7, the margin of safety between the relay calibrated for a 35% sensitivity and the 20% mismatch curve is the same as that of the relay calibrated for a 30% sensitivity and the 15% mismatch curve. This margin of safety is also shown in the voltage differential characteristic of figure 11 for the 35% sensitivity relay.

Electrical Checkpoints

The following electrical checkpoints may be used to assist in troubleshooting if the relay will not calibrate using the above calibration procedure. The values listed are approximate for current production and might change due to a minor change in design or a change in components. However, periodic checks of a given relay should reproduce very closely the same values produced when the relay was new.

Differential Unit (DU)

A. Restraint Circuit

Apply two times tap-value current successively to each restraint transformer. This is done by connecting leads to a tap screw and to terminals 5, 7, 9 (HU-1 only) in turn. The ac voltage across the appropriate restraint rectifier bridge using a high resistance voltmeter (5000 ohms per volt) should be within the range given in Table 3.

Table 3:

Rated Frequency	Voltage Range	
	50 Hz	60 Hz
DU Restraint Circuit	1.78 – 2.03	2.10 – 2.40
DU Operating Circuit		
Operate Coil Bridge	2.17 – 2.69	2.50 – 3.10
Operate Transformer	2.97 – 4.05	4.40 – 6.00
HRU		
1. Output of operate transformer (top coil terminals)	3.98 – 4.89	3.90 – 4.80
2. 4 MFD capacitor (HRU Restraint)	2.41 – 3.33	2.27 – 3.13
3. .45 MFD capacitor (HRU Operate)	2.89 – 3.97	3.30 – 4.40
Rectifier Bridges		
4. Operating	1.87 – 2.88	1.95 – 3.00
5. Restraint	<1.2	<1.0
6. Series-Filter Reactor	<1.0	<0.5

Location of the appropriate bridges is shown in figure 18.

B. Operating Circuit

Apply 30 percent tap-value current to terminal 3 and a tap screw. Using a high-resistance voltmeter, the ac voltage across the operating coil bridge and the ac voltage output of the operating transformer (top two coil terminals) should be within the range given in Table 3.

Harmonic Restraint Unit (HRU)

Apply 30 percent tap-value current to terminal 3 and a tap screw. The voltages obtained by using a high resistance ac voltmeter should be within the range given in Table 3. (Refer to figure 16.)

Diode Check

Check for open or shorted diodes using the electrical checkpoints above.

RENEWAL PARTS

Repair work can be done most satisfactorily at the factory. However, interchangeable parts can be furnished to customers who are equipped for doing repair work. When ordering parts, always give the complete nameplate data.

ENERGY REQUIREMENTS

Burden of Each Restraint Circuit					
Tap	Continuous Rating	Power Factor Angle [†]	Volt Amperes [‡]		
			At tap value current	At 8 times tap value current	At 20 times tap value current
2.9	8	71	.88	50	191
3.2	10	70	.89	51	211
3.5	11	66	.90	51	203
3.8	12	65	.91	53	220
4.2	13	58	.91	53	235
4.6	14	57.5	.91	55	248
5.0	16	52.5	.92	59	280
8.7	20	30	1.28	94	340

Burden of Operating Circuit					
Tap	Continuous Rating	Power Factor Angle [*]	Volt Amperes [‡]		
			At tap value current	At 8 times tap value current	At 20 times tap value current
2.9	8	35	2.26	76	487
3.2	10	34	2.30	78	499
3.5	11	33	2.30	81	504
3.8	12	33	2.30	83	547
4.2	13	31	2.30	84	554
4.6	14	30	2.40	88	598
5.0	16	29	2.50	92	640
8.7	20	23	3.18	132	850

[†]Degrees current lags voltage at tap value current

[‡]Voltages taken with Rectox type voltmeter

‡ Thermal Rating

One Second – 300 amperes

Thermal capacities for short times other than one second may be calculated on the basis of time being inversely proportional to the square of the current.

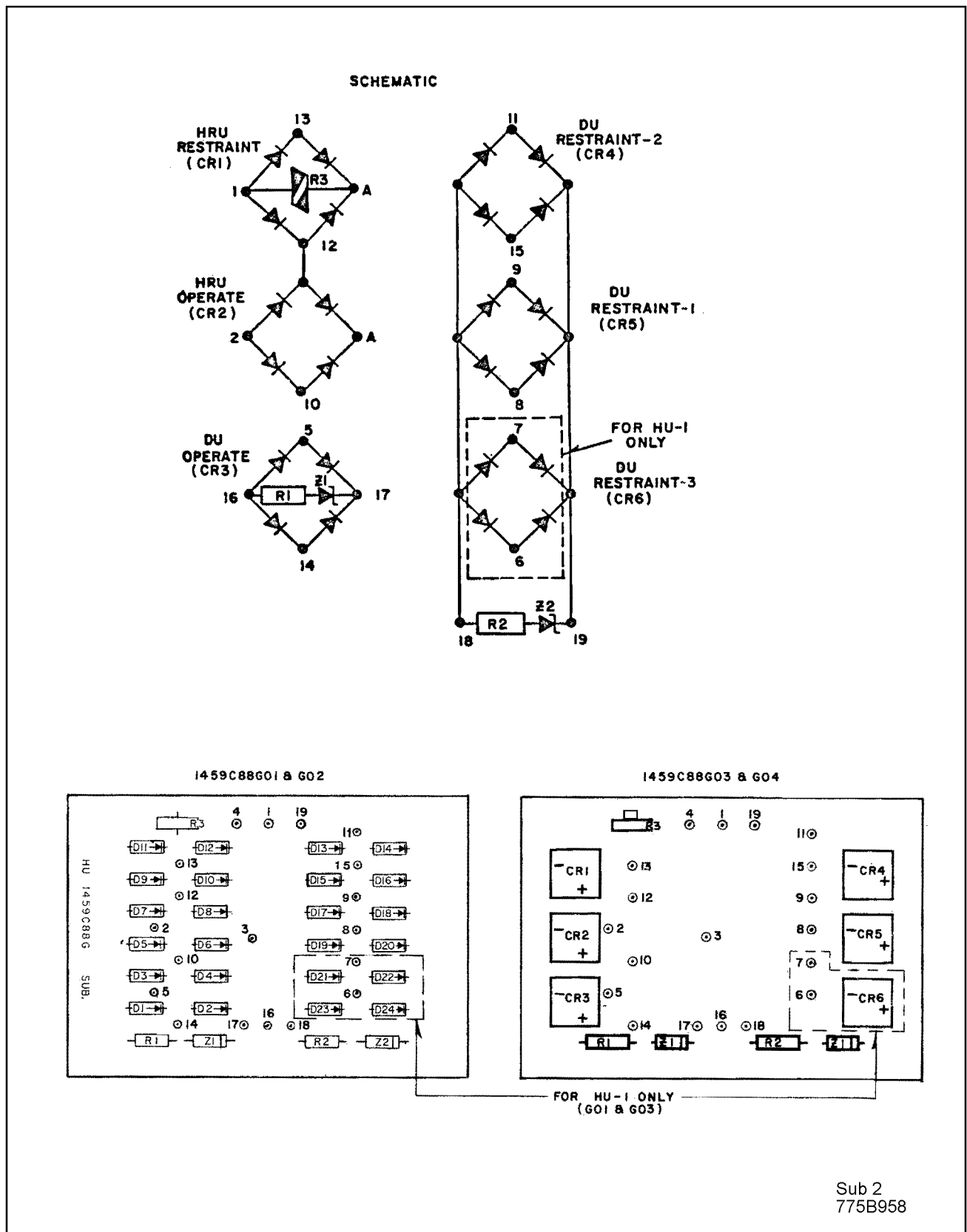
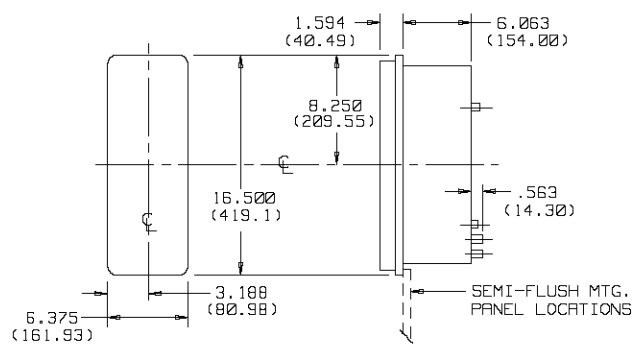
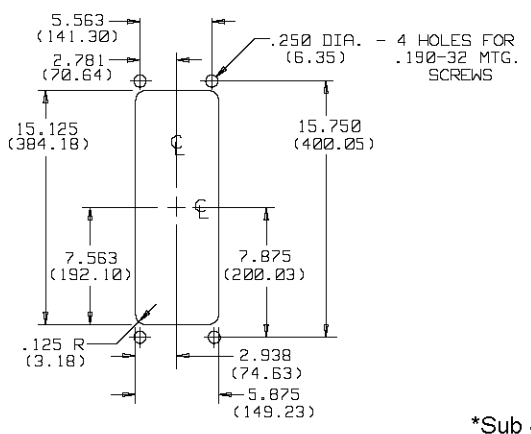
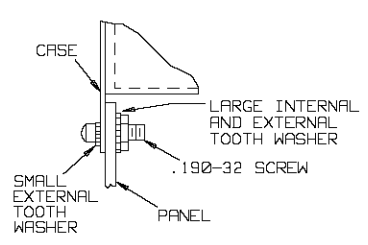

Figure 18. HU, HU-1 diode Board Module – Component Location



PANEL DRILLING AND CUTOUT
FOR SEMI-FLUSH MTG.



*Sub 4
3519A68

Figure 19. Outline and Drilling Plan of the Type HU and HU-1 Relays in the FT31 Case

* Denotes change since previous issue



ABB Inc.

4300 Coral Ridge Drive
Coral Springs, Florida 33065

Telephone: +1 954-752-6700

Fax: +1 954-345-5329

www.abb.com/substation_automation

IL 41-347.12 - Revision C