

ABB Drives

**Installation and
Start-up Guide**

Building Automation
Adapter Module
NBAA-01



Building Automation
Adapter Module
NBAA-01

**Installation and
Start-up Guide**

3AUA489002B5248 R0101 REV D
(3BFE 64307576 R0125 REV D)
NBAA-US-04
EFFECTIVE: 3/1/02
SUPERSEDES: 3/1/00

Safety Instructions

Overview

This chapter states the safety instructions that must be followed when installing and operating the NBAA-01 Building Automation Adapter Module.

The material in this chapter must be studied before attempting any work on, or with, the unit.

Warnings and Notes

This manual incorporates two types of safety instructions. Warnings are used to inform of conditions which can, if proper steps are not taken, lead to a serious fault condition, physical injury and death. Notes are used when the reader is required to pay special attention or when there is additional information available on the subject. Notes are less crucial than Warnings, but should not be disregarded.

Warnings

Readers are informed of situations that can result in serious physical injury and/or serious damage to equipment with the following symbols:



Dangerous Voltage Warning: warns of situations in which a high voltage can cause physical injury and/or damage equipment. The text next to this symbol describes ways to avoid the danger.



General Warning: warns of situations which can cause physical injury and/or damage equipment by means other than electrical. The text next to this symbol describes ways to avoid the danger.



Electrostatic Discharge Warning: warns of situations in which an electrostatic discharge can damage equipment. The text next to this symbol describes ways to avoid the danger.

Safety Instructions

Notes Readers are notified of the need for special attention or additional information available on the subject with the following symbols:

CAUTION! **Caution** aims to draw special attention to a particular issue.

Note: **Note** gives additional information or points out more information available on the subject.

**General Safety
Instructions**



WARNING! All electrical installation and maintenance work on the drive should be carried out by qualified electricians.

The drive and adjoining equipment must be properly grounded.

Do not attempt any work on a powered drive. After switching off the main power, always allow the intermediate circuit capacitors 5 minutes to discharge before working on the frequency converter, the motor or the motor cable. It is good practice to check (with a voltage indicating instrument) that the drive is discharged before beginning work.

The motor cable terminals of the drive are at a dangerously high voltage when main power is applied, regardless of motor operation.

There can be dangerous voltages inside the drive from external control circuits even when the drive's main power is shut off. Exercise appropriate care when working with the unit. Neglecting these instructions can cause physical injury and death.



WARNING! There are several automatic reset functions in the drive. If selected, they reset the unit and resume operation after a fault. These functions should not be selected if other equipment is not compatible with this kind of operation, or if such action can create a dangerous situation.

More Warnings and Notes are printed throughout this manual where applicable.

Safety Instructions

Table of Contents

Safety Instructions	iii
Overview	iii
Warnings and Notes	iii
Warnings	iii
Notes	iv
General Safety Instructions.....	v
Table of Contents.....	vii
Chapter 1 – Introduction to This Guide	1-1
Overview	1-1
Intended Audience	1-1
What This Guide Contains	1-2
Conventions Used in This Guide	1-4
Chapter 2 – Overview	2-1
Overview	2-1
FLN	2-1
System 600 Overview	2-1
Application.....	2-3
Metasys N2	2-4
Metasys Integration	2-4
Device Type	2-5
DDL File	2-5
Compatibility.....	2-7
Delivery Check	2-7
Warranty and Liability Information.....	2-7
Chapter 3 – Mechanical Installation	3-1
Overview	3-1
Mounting Outside the Drive	3-1
Mounting Inside the Drive	3-3

Table of Contents

- Chapter 4 – Electrical Installation 4-1**
 - Overview..... 4-1
 - Cabling..... 4-1
 - Bus Termination..... 4-1
 - NBAA-01 Connections..... 4-2
 - Grounding 4-4
 - Grounding the Bus Cable Shields..... 4-5

- Chapter 5 – Programming 5-1**
 - Overview..... 5-1
 - Building Automation / ABB Coordination 5-1
 - Supported Features..... 5-1
 - Configuring the System 5-1
 - Bus Connection Configuration 5-1
 - Control Locations..... 5-5

- Chapter 6 – Fault Tracing 6-1**
 - Overview..... 6-1
 - Installation Problems..... 6-1
 - Drive Setup 6-1
 - Status LEDs..... 6-2
 - Module Diagnostics..... 6-2

- Appendix A – FLN Points..... A-1**

- Appendix B – N2 Points B-1**
 - Parameters B-1
 - ACS 600.DDL B-8
 - ACH 400.DDL B-10

- Appendix C – Technical Data C-1**
 - DDCS Link..... C-1
 - Fieldbus Link..... C-2
 - NBAA-01..... C-3

Appendix D – Installation Check-list..... D-1

Appendix E – Ambient Conditions..... E-1

 Ambient Conditions, Operation E-1

 Ambient Conditions, Storage E-1

 Ambient Conditions, Transportation..... E-2

Table of Contents

Chapter 1 – Introduction to This Guide

Overview

This chapter contains a description of the *Start-up and Installation Guide* for the NBAA-01 Building Automation Adapter Module.

Intended Audience

This Guide is intended for the person(s) responsible for installing, commissioning and using a Building Automation Adapter Module with an ABB drive. The reader is expected to have a basic knowledge of electrical fundamentals, electrical wiring practices, the drive, use of the drive control panel, and the FLN or Metasys N2 protocol.

Chapter 1 – Introduction to This Guide

What This Guide Contains

Proper installation and start-up of the NBAA-01 Building Automation Adapter Module is introduced in this Guide.

It is assumed that the drive is installed and ready to operate before beginning the adapter module installation. For more information on the drive's installation and start-up procedures, please refer to the user documentation supplied with the drive.

Safety Instructions are featured in the first few pages of this Guide. Safety Instructions describe the formats for various warnings and notations used within this Guide. This chapter also states the safety instructions which apply to the installation and operation of the NBAA-01 Module.

Chapter 1 – Introduction to This Guide contains a short description of the Guide.

Chapter 2 – Overview contains a short description of the FLN and Metasys N2 protocols as well as the NBAA-01 Building Automation Adapter Module, a delivery checklist, and information on the manufacturer's warranty.

Chapter 3 – Mechanical Installation contains placement and mounting instructions for the module.

Chapter 4 – Electrical Installation contains wiring, bus termination and grounding instructions.

Chapter 5 – Programming explains how to program the master station and drive before communication through the adapter module can be started.

Chapter 6 – Fault Tracing explains how to trace faults with the Status LEDs on the NBAA-01 Module.

Chapter 1 – Introduction to This Guide

Appendix A presents the FLN Points in supported ABB drives.

Appendix B presents the N2 Points in supported ABB drives.

Appendix C contains Technical Data.

Appendix D contains an installation check-list.

Appendix E contains a specification of the ambient conditions allowed during transportation, storage and use of the NBAA-01.

Conventions Used in This Guide

<i>Communication Module</i>	Communication Module is a parameter name/parameter selection name for a device (e.g. a fieldbus adapter) through which the drive is connected to an external serial communication network (e.g. a fieldbus). Communication with the module is activated with a drive parameter.
<i>NBAA-01 Building Automation Adapter Module</i>	The NBAA-01 Adapter Module is one of the optional fieldbus adapter modules available for ABB drives. The NBAA-01 is a device through which an ABB drive is connected to an FLN or N2 serial communication bus.
<i>LAN Parameter</i>	Local Area Network A parameter is an operating instruction for the drive. Parameters can be read and programmed with the drive control panel.
<i>Point</i>	A point is an actual value or operating instruction for the drive, which can be read and programmed from the FLN LAN or Metasys N2 Bus through the NBAA-01 Module.
<i>Analog Inputs</i>	Analog Input points are real number values which are inputs to the Metasys. In the ABB drive, the analog input values include the actual values.
<i>Analog Outputs</i>	Analog Output points are real number values which are outputs from the Metasys. In the ABB drive, the analog output values include the set point values.
<i>Binary Inputs</i>	Binary Input points are boolean values which are inputs to the Metasys. In the ABB drive, the binary inputs include the drive status information.
<i>Binary Outputs</i>	Binary Output points are boolean values which are outputs from the Metasys. In the ABB drive, the binary outputs include the drive control for start and stop, direction, and fault reset.

Chapter 2 – Overview

Overview

This chapter contains a short description of the FLN and N2 protocols and the NBAA-01 Adapter Module, a delivery checklist, and warranty information.

FLN

The FLN LAN protocol is a master – slave type serial communication protocol used by the Landis & Staefa System 600 system.

In the System 600 architecture, the FLN LAN connects controllers (like ACS 600 drives) to field panels.

System 600 Overview

System 600 has three levels of communication networks. FLN LAN is used as a Local Area Network on the Floor level. A simplified overview of the architecture is shown in *Figure 2-1 'System 600 Architecture'*.

Campus Level Network: Ethernet Data Highway

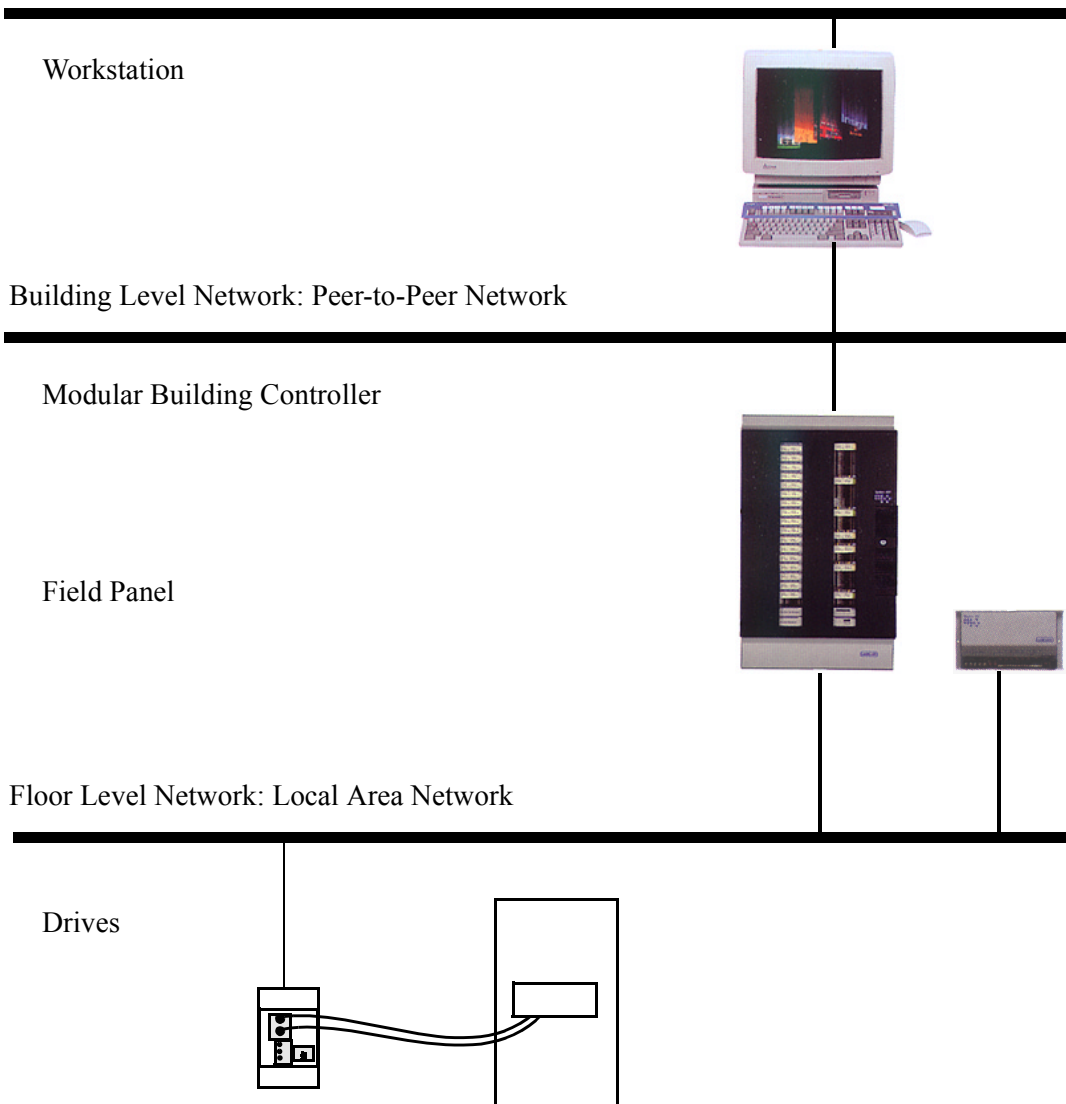

Figure 2-1 System 600 Architecture

On the FLN LAN network, each ABB drive can be accessed by the full complement of System 600 features, including English and SI units, point data-base inside the drive, and full scaling.

ABB drives have a pre-defined set of Analog and Digital I/O points. A complete list of these points is provided in 'Appendix A - FLN Points' of this manual.

One FLN LAN segment can support a maximum of 32 FLN devices.

Application

The System 600 unique application identification number for latest application is 2723 for ACS 600 drives and 2724 for ACH 400 drives. This is used to identify the list of points for the drive in the system.

Metasys N2

The N2 Bus protocol is a master - slave type serial communication protocol used by the Johnson Controls Metasys system. In the Metasys architecture, the N2 Bus connects point interfaces and remote controllers to Network Control Units (NCUs).

The N2 Bus can also be used to connect ABB drives to the Johnson Controls Companion product line.

Metasys Integration

Figure 2-2 “ABB and Metasys Integration” shows the drives’ integration to the Johnson Controls Metasys system.

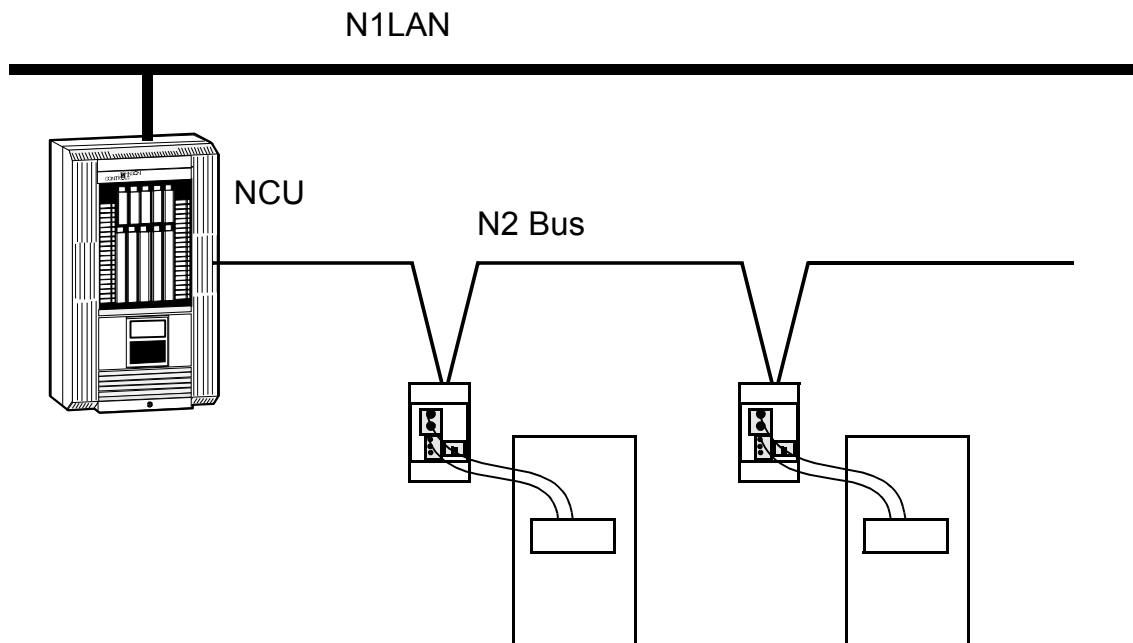

Figure 2-2 ABB and Metasys Integration

Figure 2-3 “ABB and Metasys Companion Integration” shows the drives’ integration into the Johnson Controls Metasys Companion system.

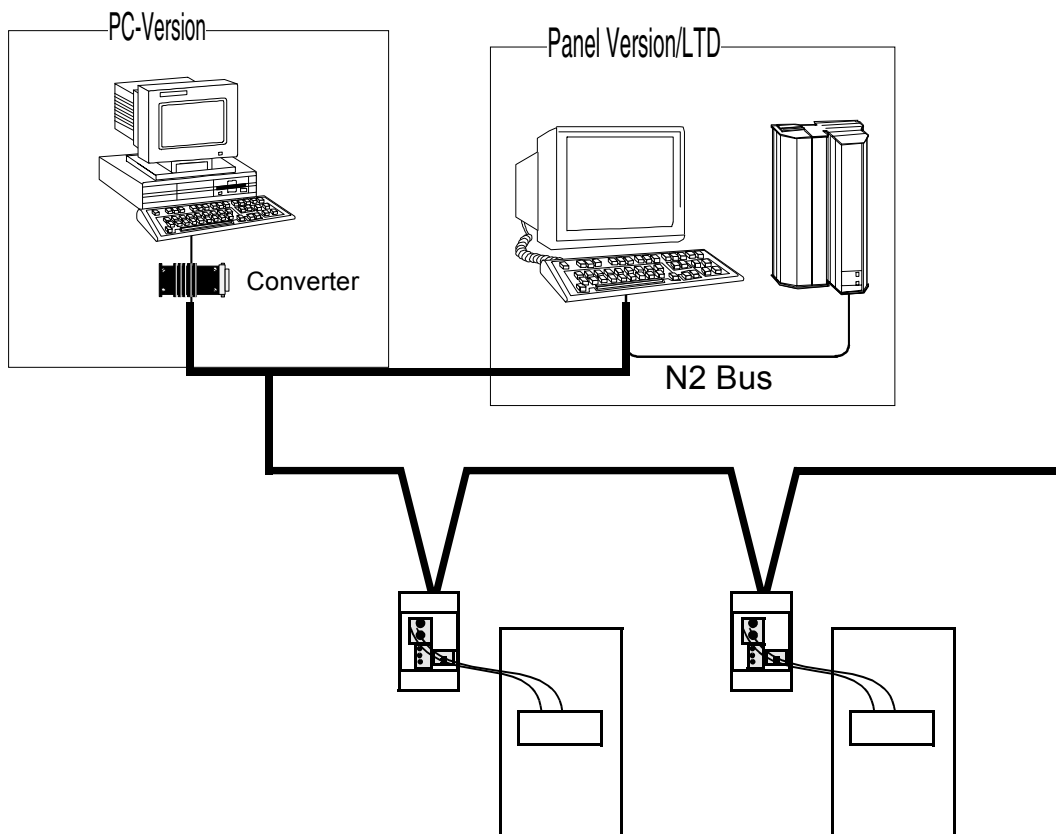

Figure 2-3 ABB and Metasys Companion Integration

On the N2 Bus, each ABB drive can be accessed by the full complement of Metasys FMS features, including Change-of-State (COS) monitoring, alarm notification, scheduling, trend, and totalization.

The ABB drives have a pre-defined set of Analog and Binary I/O points. A complete list of these points is provided in *Appendix B* of this manual.

One N2 Bus segment can support up to 32 nodes (out of the maximum of 50 recommended by Johnson Controls) while integrating ABB drives with Johnson Controls Metasys.

Device Type

For the Metasys and Metasys Companion products, the device type for the ABB drives is VND.

DDL File

To simplify the definition of points for the NCU unit, the ACS600 .DDL and ACH400 .DDL files are listed in *Appendix B*.

The NBAA-01 Building Automation Adapter Module

The NBAA-01 Building Automation Adapter Module is an optional device for ABB drives which enables the connection of the drive to a FLN or Metasys system. The drive is considered a slave in the network. Through the NBAA-01 Building Automation Adapter Module it is possible to:

- Give control commands to the drive (Start, Stop, Run enable, etc.)
- Feed a motor speed reference to the drive
- Give a process reference to the drive's PID
- Read status information and actual values from the drive
- Change some drive parameter values
- Reset a drive fault

The adapter module is mounted on a standard mounting rail inside or outside the drive unit, depending on drive type and configuration. See the drive's user's manual for module placement options.

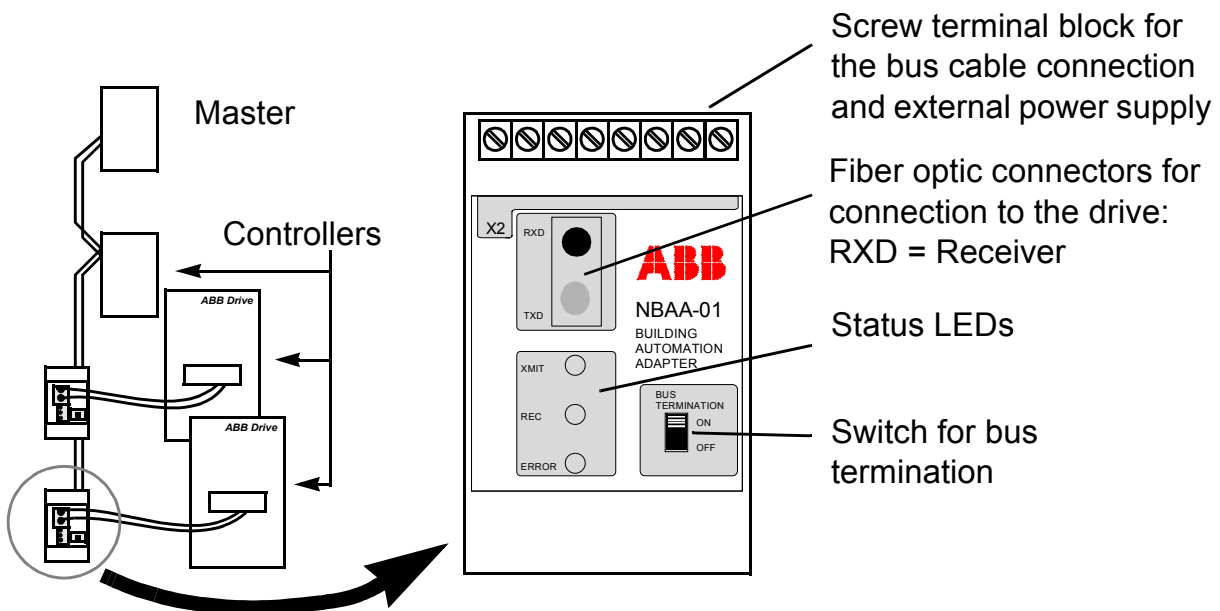

Figure 2-4 Construction of the network and the NBAA-01 Adapter Module.

Compatibility

The NBAA-01 is compatible with (see also Chapter 5, Parameter no. 8 *COMM PROFILE*):

- ACS 600 Standard Application Program
- ACS 400

Delivery Check

The option package for the NBAA-01 Building Automation Adapter Module contains:

- Building Automation Adapter Module, Type NBAA-01
- Two pairs (four pieces) of fiber optic cables for connecting the adapter to the drive
- Mounting rail
- This manual, the *Installation and Start-up Guide for NBAA-01*.

Warranty and Liability Information

The warranty for your ABB drive and options covers manufacturing defects. The manufacturer carries no responsibility for damage due to transport or unpacking.

In no event and under no circumstances shall the manufacturer be liable for damages and failures due to misuse, abuse, improper installation, abnormal conditions of temperature, dust, or corrosives, or failures due to operation above rated capacities. Nor shall the manufacturer ever be liable for consequential and incidental damages.

The period of manufacturer's warranty is 12 months, and not more than 18 months, from the date of delivery.

An extended warranty may be available with certified start-up. Contact your local distributor for details.

Your local ABB Drives company or distributor may have a different warranty period, which is specified in their sales terms, conditions, and warranty terms.

If you have any questions concerning your ABB drive, contact your local distributor or ABB Drives office.

The technical data and specifications in this Guide are valid at the time of printing. ABB reserves the right to make subsequent alterations.

Chapter 3 – Mechanical Installation

Overview

This chapter contains instructions for mounting the module. Depending on the drive, the module can be installed either inside or outside the drive housing or cabinet. See the drive's user's manual for a complete description of your module placement options.

Mounting Outside the Drive

Choose the location for the module. Note the following:

- The cabling instructions must be followed (see Chapter 4). The length of the fiber optic cables included in the option package restricts the distance between the module and the drive.
- Observe the free space requirements for the module (min. 10 mm from adjoining equipment or walls) and the drive (see the drive documentation).
- The ambient conditions should be taken into account (see Appendix E). The module's degree of protection is IP 20.

The module ground is connected to the mounting rail by means of a grounding clip (see Figure 3-1 below). The mounting rail onto which the option module is to be mounted must be grounded to a noiseless ground. If the rail is not mounted on a properly grounded base, a separate grounding conductor must be used. The conductor must be as short as possible and the cross-sectional area must be at least 6 mm². **Note:** No solid copper conductor may be used (stranded wire allowed only).

Chapter 3 – Mechanical Installation

Mounting instructions:

1. Switch off all dangerous voltages in the enclosure that will house the module.
2. Fasten the rail and ensure proper grounding as described above.
3. Push the module onto the rail. The module can be released by pulling the locking spring with a screwdriver (see Figure 3-1).

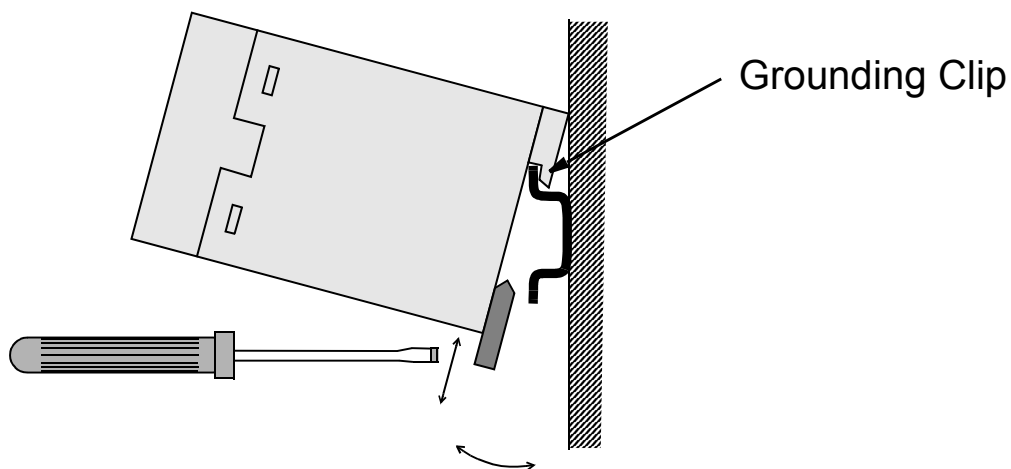

Figure 3-1 Mounting and removing the module.

Mounting Inside the Drive

The work inside the drive should be performed by a qualified electrician.



WARNING! Pay attention to the slowly discharging voltage of the capacitor bank and the voltages that are connected from external control circuits to the inputs and outputs of the drive.



WARNING! Do not touch the printed circuit boards. The integrated circuits are extremely sensitive to electrostatic discharge.

Mounting instructions:

1. Stop the drive.
2. Switch off the drive's power supply as well as all dangerous voltages connected to the inputs and outputs.
3. Wait for five minutes to ensure that the capacitors in the intermediate circuit have discharged.
4. Remove the drive's front cover.
5. Ensure that the line power cable, motor cable and capacitor bank (UDC+ and UDC-) are not powered.
6. Locate the position for the module (see the drive's user's manual). Fasten the mounting rail into place if not already installed. Observe the free space requirements for the module (min. 10 mm from adjoining equipment and walls).
7. Push the module onto the rail. The module can be released by pulling the locking spring with a screwdriver (see Figure 3-1)

Chapter 4 – Electrical Installation

Overview

This chapter contains:

- Cabling instructions
- Instructions for bus termination
- Connection and grounding instructions for the NBAA-01 Module and grounding instructions for the bus cable.



WARNING! Before installation, switch off the drive's power supply. Wait for five minutes to ensure that the drive's capacitor bank is discharged. Switch off all dangerous voltages connected from external control circuits to the inputs and outputs of the drive.

Cabling

Route the bus cables as far away from the motor cables as possible. Avoid parallel runs. Use bushings at all cable entry and exit points.

Handle the fiber optic cables with care. When unplugging the cables, always grab the connector, not the cable itself. Do not touch the ends of the fibers with bare hands as the fiber is extremely sensitive to dirt.

The maximum long term tensile load for the fiber optic cable is 1 N.

The minimum short term bend radius is 25 mm.

Bus Termination

The built-in terminating resistors must be switched on if the NBAA-01 module is installed at the end of the bus. Otherwise the resistors must be switched off. Terminating resistors prevent signal reflections from the bus cable ends.

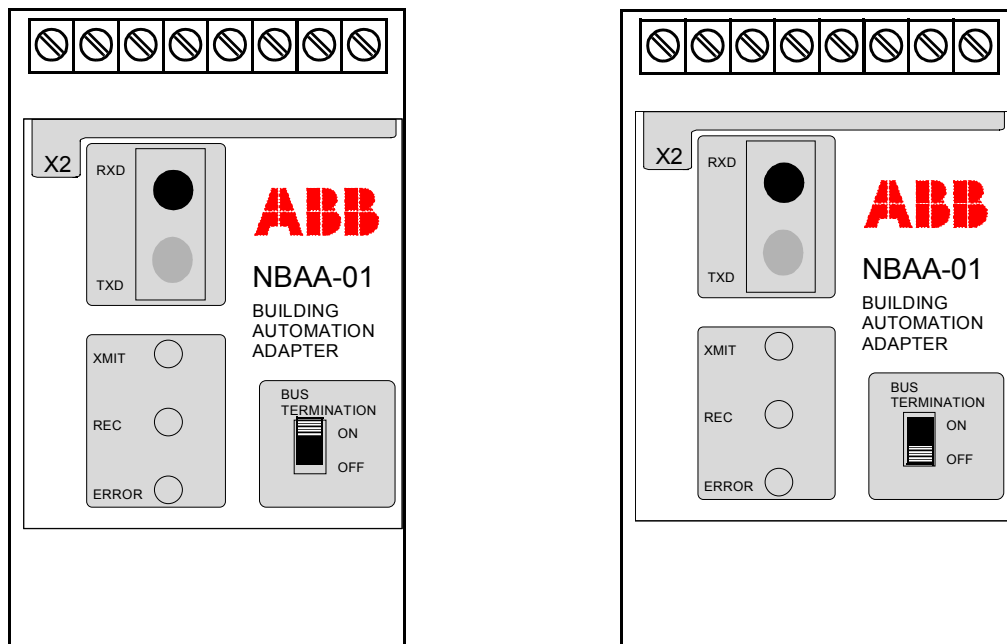

Figure 4-1 Terminating resistors on (left) and off (right).

NBAA-01 Connections

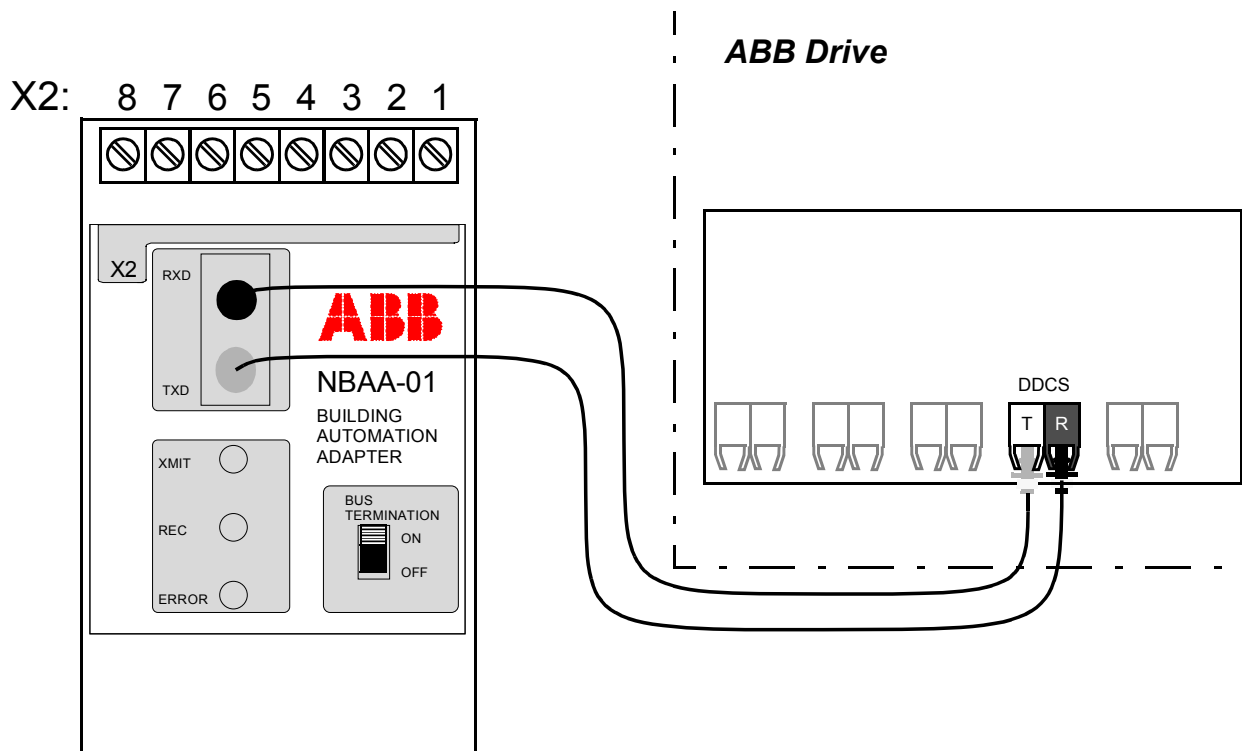

Figure 4-2 Fiber optic link connecting the NBAA-01 adapter to the drive.

Chapter 4 – Electrical Installation

The NBAA-01 module is connected to the drive using a fiber optic cable link. Consult the drive documentation as to the corresponding terminals inside the drive.

The bus cable and the external power supply are connected to terminal block X2 on the NBAA-01.

Table 4-1 Description of terminal block X2.

X2		Description
1	D(P)	D(P) = B = Data Positive (Conductor 1 in twisted pair) D(N) = A = Data Negative (Conductor 2 in twisted pair) DG = Data Ground
2	D(N)	
3	DG	
4	SHF	Cable shield AC grounding (via an RC filter)
5	SH	Cable shield grounding (directly grounded)
6	0V	Power supply for the module (24 VDC \pm 10 %); shielded cable.
7	+24 V	
8	PE	Ground

Grounding

The NBAA-01 module ground is connected to the rail onto which the module is mounted. If the rail is fastened to a grounded metallic assembly plate, the module is automatically grounded and no external grounding wire is needed. If the rail is fastened to a base that is not grounded, the rail must be connected to the nearest grounding terminal. However, the grounding wire should not be connected to the same terminal as the power cable screens. (See page 3-1.)

The NBAA-01 module has several built-in grounding terminals (see Figure 4-3 below):

- The **PE** terminal is internally connected to the NBAA-01 module ground. Normally, no external wires need to be connected to this terminal.
- The **SH** terminal is internally connected to the NBAA-01 module ground. The SH terminal is normally used for grounding the FLN cable shield if there is no other station at which the cable shield is directly grounded.
- The **SHF** terminal is internally connected to the NBAA-01 module ground via an RC filter. The SHF terminal is typically used for grounding the FLN cable shield.
- The **DG** terminal is isolated from the NBAA-01 module ground. This terminal is used for connecting the third conductor of the bus cable. The third conductor – Data Ground – offers a common reference or comparison potential to all modules on the bus.

Note: The use of Data Ground is recommended as it improves noise immunity. See the diagram on the next page.

Grounding the Bus Cable Shields

The bus cable shield may be directly grounded at one station only. At other stations, the cable shield should be grounded via an RC filter.

There are two wiring examples in the figures below. The three-wire connection (*Figure 4-4*) is preferred because of its better noise immunity.

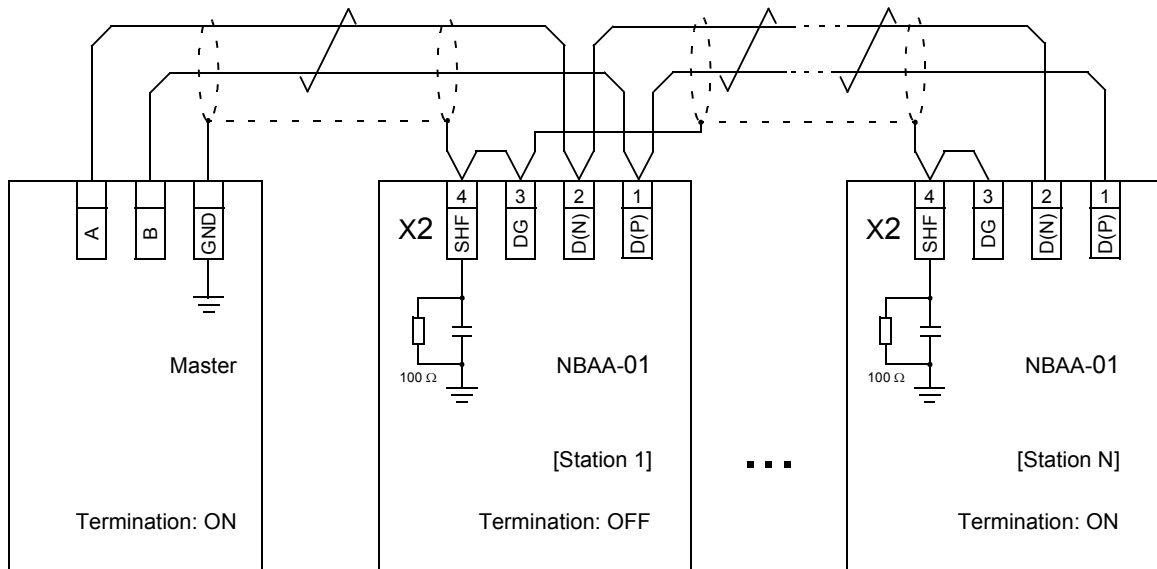

Figure 4-3 2-wire Bus Cable connections.

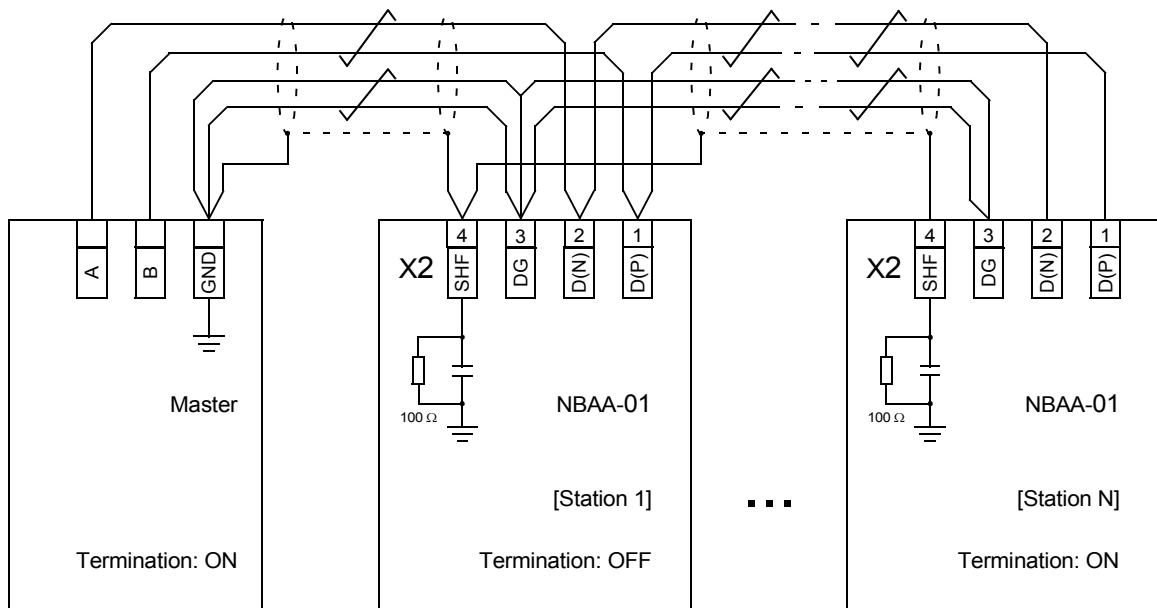

Figure 4-4 3-wire Bus Cable connections (preferred practice).

Chapter 5 – Programming

Overview

This chapter describes the programming of ABB drives for the Building Automation protocols. The reader should be familiar with the ABB drive and the Building Automation system in use.

Building Automation / ABB Coordination

Coordinate drive programming with the local building automation system representative so that the drive's RS485 bus address is setup correctly. The building automation system representative should communicate which drive control functionality will be required for each drive (control locations) so that ABB start-up personnel can setup the drives correctly for the installation.

Supported Features

ABB drives "look" like a building automation system slave device to the master device. A complete list of the points inside the supported drives is located in 'Appendix A -FLN Points' and 'Appendix B -N2 Points'.

Configuring the System

After the NBAA-01 Building Automation Adapter Module has been mechanically and electrically installed according to the instructions in Chapters 3 and 4, the drive must be prepared for communication with the module.

Bus Connection Configuration

The detailed procedure of activating the module for communication with the drive is dependent on the drive type.

Chapter 5 – Programming

ACS/H400 Configuration

To activate the NBAA-01 adapter with ACS/H400 drives set parameter 5005 PROTOCOL SEL to DDCS or STD MDB+DDCS. If you need to control (start/stop the drive or give reference) via NBAA-01, set also the parameter 5006 COMM COMMAND to DDCS.

ACS600 Configuration

To activate the NBAA-01 adapter with ACS600 drives set parameter 9802 COMM MODULE to FIELDBUS.

As communication between the drive and the NBAA-01 is established, several configuration parameters are copied to the drive parameter group 51. These parameters – shown below in Table 5-1 – must be checked first and adjusted if necessary. The alternative selections for these parameters are discussed in more detail below the table. (Note that the new settings take effect only when the module's power is cycled off and then on after the change.)

Note: The parameter grouping, numbering, and adjustment procedure varies from drive to drive. See the drive documentation for further information.

Table 5-1 Group 51 the NBAA-01 configuration parameters.

Field-bus Par. No.	Parameter Name	Alternative Settings	Default Setting
1	MODULE TYPE		NBAA-01 vn.n
2	PROTOCOL	(0) NONE; (1) FLN; (2) N2	NONE
3	STATION NUMBER	0 to 255	1
4	BAUD RATE	(0) 1200; (1) 2400; (2) 4800; (3) 9600; (4) 19200	1200
5	COMM PROFILE	(0) ABB DRIVES; (1) CSA 2.8/3.0	ABB DRIVES
6	WATCHDOG MODE	(0) FAULT, (1) RESET	FAULT
7	GOOD MESSAGES	0 to 32767	0
8	BAD MESSAGES	0 to 32767	0

MODULE TYPE

This parameter shows the module type as detected by the drive. The value cannot be adjusted by the user. (If this parameter is undefined, the communication between the drive and the module has not been established.)

PROTOCOL

This parameter selects the protocol to be used. FLN protocol is used by Siemens Building Technologies Landis Division systems and N2 is used by Johnson Controls Metaysys systems. If NONE is selected, the NBAA-01 adapter is not communicating to the RS485 bus.

STATION NUMBER

Each device on the RS485 bus must have a unique station number. This parameter selects the drive's RS485 bus address. Confirm the

Chapter 5 – Programming

value with your Building Automation System representative.

BAUD RATE

This parameter selects the communication speed on the RS485 bus. 1200 Baud is the default value.

COMM PROFILE

This parameter selects the communication profile used in the DDCS link between the drive and the NBAA-01. The proper setting is dependent on drive type and software version as indicated below. (The drive software version can be checked by viewing a parameter; see the drive documentation.)

Drive Type	Drive SW Version	Setting to Use
ACS 600 SingleDrive	ACxA5000 or later	ABB DRIVES or CSA 2.8/3.0
ACH 400		ABB DRIVES

ABB DRIVES

The Control and Status Word bits in the drive are assigned as defined by the ABB Drives Profile (based on the PROFIBUS standard). For NBAA-01 this means that, if the drive is controlled via a building automation system, the point RUN ENABLE must be set before starting the drive, even if it has been configured to be set from another source by a parameter in the drive. When the drive is stopped via a building automation system by writing START/STOP point (24 in FLN or Binary Output 1 in N2), it will always ramp to stop even if a different stop type has been chosen by a parameter. If coast to stop is required, the drive can be stopped by setting RUN ENABLE to OFF.

CSA 2.8/3.0

Run enable and stop type are defined by the parameter settings in the drive if it is controlled via a building automation system.

NOTE: With the ACS600, parameter 98.7 has to have the same value as the COMM PROFILE in the Communication Module

	parameter group.
WATCHDOG MODE	<p>There are two possible selections for watchdog mode:</p> <p>FAULT On a watch-dog error, the module will indicate a watch-dog error.</p> <p>RESET On a watch-dog error, the module will reset itself.</p> <p>If the NBAA-01 can have short disconnects in its power supply, it may go to watch-dog error mode. If this happens frequently, this parameter should be set to RESET.</p>
GOOD MESSAGES	<p>This diagnostics counter increases by one every time a valid message is received by the NBAA-01 Adapter. This counter will roll over from 32767 back to 0. During normal operation, this counter increases constantly.</p>
BAD MESSAGES	<p>This diagnostics counter increases by one every time the NBAA-01 Adapter finds any kind of communication error. This counter will roll over from 32767 back to 0. When adding the drive application to a FLN field panel for the first time, it is normal for this counter to increase when the field panel is scanning all points from the drive and addresses non existing points. During normal operation, this counter seldom increases.</p>
Control Locations	<p>ABB drives can receive control information from multiple sources including digital inputs, analog inputs, the drive control panel and a communication module (e.g. NBAA-01). ABB drives allow the user to separately determine the source for each type of control information (Start, Stop, Direction, Reference, Fault Reset, etc.). In order to give the fieldbus master station the most complete control over the drive, the communication module must be selected as the source for this information. See the drive's user documentation for more information on the selection parameters.</p>

Output Point Configuration

The NBAA-01 implementation follows the normal control place logic configuration on the ACS/H 400 and ACS600 drives. This will mean that to use output points to control the drive, the drive must also be configured to receive commands from a Communication port.

In ACS/H400 before any control commands can be given through the NBAA-01 adapter, parameter 5006 COMM COMMANDS value must be set to DDCS.

Required setups for each individual point are listed below.

FLN Outputs

Below is a list of all the output points for the FLN interface for the ACS/H400 and ACS600 drives.

22 CMD FWD.REV

Set Parameter 1003 to REQUEST. Also, depending on the selected reference, setup the following Parameter:

- Set Parameter 1103 EXT REF1 SELECT to COMM, when using Reference R1.
- Set Parameter 1106 EXT REF2 SELECT to COMM, when using Reference R2.

24 CMD STP.STRT

Set Parameter 1001 EXT1 COMMANDS to COMM, when using Reference R1. Set Parameter 1002 EXT2 COMMANDS to COMM, when using Reference R2.

When this point is overridden to 0, the drive will ramp to stop. Use the Binary Output 4 RUN ENABLE for stopping the drive by coast.

30 CURRENT LIM

No setup is necessary.

31 ACCEL TIME 1

No setup is necessary.

32 DECEL TIME 1

No setup is necessary.

33 LOCK PANEL

No setup is necessary.

34 SEL HND.AUTO

Set Parameter 1102 EXT1/EXT2 SEL to COMM.

35 RUN ENABLE

No setup is necessary.

Note that this point must always be set to 1 to start the drive. If Binary Output 1 STOP/START

is kept high and this point is overridden to 0, the drive will coast to stop.

40 CMD DRV RO 1	<p>For ACS/H400 set Parameter 1401 RELAY OUTPUT 1 to 7 “SUPERV1 OVER”, set Parameter 3201 SUPERV 1 PARAM to 131 “SERIAL LINK DATA 1” and set Parameter 3203 SUPERV 1 LIM HI to 1.</p> <p>For ACS600 set Parameter 14.01 RELAY RO1 OUTPUT to “COMM MODULE”.</p>
41 CMD DRV RO 2	<p>For ACS/H400 set Parameter 1402 RELAY OUTPUT 2 to 9 “SUPERV2 OVER”, set Parameter 3204 SUPERV 2PARAM to 132 “SERIAL LINK DATA 2” and set Parameter 3206 SUPERV 2 LIM HI to 1.</p> <p>For ACS600 set Parameter 14.02 RELAY RO2 OUTPUT to “COMM MODULE”.</p>
42 CMD DRV RO 3	<p>This point does not exist for ACS/H400 drive.</p> <p>For ACS600 set Parameter 14.03 RELAY RO3 OUTPUT to “COMM MODULE”.</p>
48 CMD DRV AO 1	<p>For ACS/H400 set the parameter 1501 AO CONTENT to 133 (SERIAL LINK DATA 3) and set the parameter 1503 AO CONTENT MAX to 255.</p> <p>For ACS600 set Parameter 15.01 ANALOGUE OUTPUT1 to “COMM MODULE”.</p>
49 CMD DRV AO 2	<p>This point does not exist for ACS/H400 drive.</p> <p>For ACS600 set Parameter 15.06 ANALOGUE OUTPUT2 to “COMM MODULE”.</p>
50 INPUT REF 1	<p>Set the parameter 1103 EXT REF1 SELECT to COMM.</p>
51 INPUT REF 2	<p>Set the parameter 1104 EXT REF2 SELECT to COMM.</p>
61 PID GAIN	<p>No setup is necessary.</p>
62 PID I TIME	<p>No setup is necessary.</p>
63 PID D TIME	<p>No setup is necessary.</p>
64 PID D FILTER	<p>No setup is necessary.</p>
94 RESET FAULT	<p>Set Parameter 1604 FAULT RESET SEL to COMM.</p>

Chapter 5 – Programming

N2 Analog Outputs

Below is a list of all the analog output points for the N2 Bus interface for the ACS/H400 AND ACS600 drives.

- | | |
|---------------------|--|
| 1 REFERENCE 1 | Set the parameter 1103 EXT REF1 SELECT to COMM. |
| 2 REFERENCE 2 | Set the parameter 1104 EXT REF2 SELECT to COMM. |
| 3 CURRENT LIMIT | No setup is necessary. |
| 4 ACCEL TIME 1 | No setup is necessary. |
| 5 DECEL TIME 1 | No setup is necessary. |
| 6 PID-CONT GAIN | No setup is necessary. |
| 7 PID-CONT I-TIME | No setup is necessary. |
| 8 PID-CONT D-TIME | No setup is necessary. |
| 9 PID-CONT D-FILTER | No setup is necessary. |
| 10 COMMAND AO 1 | Set the parameter 1501 AO CONTENT to 133 (SERIAL LINK DATA 3) and set the parameter 1503 AO CONTENT MAX to 255.

For ACS600 set Parameter 15.01 ANALOGUE OUTPUT1 to “COMM MODULE”. |
| 11 COMMAND AO 2 | This point does not exist for ACS/H400 drive.

For ACS600 set Parameter 15.06 ANALOGUE OUTPUT2 to “COMM MODULE”. |

N2 Binary Outputs

Below is a list of all the analog output points for the N2 Bus interface for the ACS/H 400 and ACS600 drive.

- | | |
|-------------------|---|
| 1 STOP/START | Set the parameter 1001 EXT1 COMMANDS to COMM, when using the Reference R1. Set the parameter 1002 EXT2 COMMANDS to COMM, when using the Reference R2.

When this point is overridden to 0, the drive will ramp to stop. Use the Binary Output 4 RUN ENABLE for stopping the drive by coast. |
| 2 FORWARD/REVERSE | Set the parameter 1003 to REQUEST. Also depending on the selected reference setup the following parameter: |

- Set the parameter 1103 EXT REF1 SELECT to COMM, when using the Reference R1.
 - Set the parameter 1104 EXT REF2 SELECT to COMM, when using the Reference R2.
- 3 PANEL LOCK** No setup is necessary.
- 4 RUN ENABLE** No setup is necessary.
Note that this point must always be set to 1 to start the drive. If Binary Output 1 STOP/START is kept high and this point is overridden to 0, drive will coast to stop.
- 5 REF1/REF2** Set the parameter 1102 EXT1/EXT2 SEL to COMM.
- 6 FAULT RESET** Set the parameter 1604 FAULT RESET SEL to COMM.
- 7 COMMAND RO 1** Set the parameter 1401 RELAY OUTPUT 1 to 7 “SUPERV1 OVER”, SET PARAMETER 3201 SUPERV 1 PARAM to 131 (SERIAL LINK DATA 1) and set the parameter 3203 SUPERV 1 LIM HI to 1.
For ACS600 set Parameter 14.01 RELAY RO1 OUTPUT to “COMM MODULE”.
- 8 COMMAND RO 2** Set the parameter 1402 RELAY OUTPUT 2 to 9 “SUPERV2 OVER”, SET PARAMETER 3204 SUPERV 2PARAM to 132 (SERIAL LINK DATA 2) and set the parameter 3206 SUPERV 2 LIM HI to 1.
For ACS600 set Parameter 14.02 RELAY RO2 OUTPUT to “COMM MODULE”.
- 9 COMMAND RO 3** This point does not exist for ACS/H400 drive.
For ACS600 set Parameter 14.03 RELAY RO3 OUTPUT to “COMM MODULE”.

Chapter 6 – Fault Tracing

Overview

This chapter gives step-by-step diagnostic information for determining the root causes and corrections for the most common problems with the NBAA-01 module.

This section is divided into different sections, with each section first listing the symptoms, followed by the possible causes and remedies.

Installation Problems

Verify all the connections on the module:

- RS485 bus cable is connected correctly to terminal block X2.
- 24 VDC power is connected to the power connectors.
- Fiber optic link cable is connected between the drive and the NBAA-01.
- Check that the fiber optic link connector's colors match between the drive and the NBAA-01 connector.

Drive Setup

Communication Module Parameters are not visible on the control panel.

- See the drive's user documentation to get information on how to enable communication between the module and drive.

The NBAA-01 is using default values.

- Verify that the Communication Module Parameter group is setup correctly. If so, cycle the power to the NBAA-01 off and then on. This should cause the module to re-read its setup parameters.

Drive values can be read, but control commands (Start/Stop or Reference) do not work.

- Check that the control location parameters are set to COMM. MODULE for the required operation.
- Check that the drive is in REMOTE control.

Status LEDs

The NBAA-01 has three status LEDs. These are, from top to bottom:

- Transmit LED. This LED will flash each time the NBAA-01 transmits a response or an exception on the RS485 bus.
- Receive LED. This LED will flash each time the NBAA-01 receives a command from the RS485 bus.
- Combined error and module status LED. This LED will flash for the following reasons:
 - If the received command had a parity error.
 - If the received command had a CRC error.
 - If the received command or addressed point was not supported by the NBAA-01 MODULE. In this case the Transmit LED will also flash.
 - If the NBAA-01 module has found an error. These error codes are described below.

Module Diagnostics

On module power-up, the NBAA-01 goes through a power-up self-test sequence. During this sequence, the test state is indicated by the three front LEDs.

If there is a failure, the module status LEDs remain in the state that was not passed. *Table 6-1 'NBAA-01 Error Code'* below shows the error codes.

Table 6-1 NBAA-01 Error Code

Flash Code	Status	Correction
Occasional flash on Error LED	Module on-line. Parity, CRC or unsupported command received.	Check the wiring and grounding of the module. Verify that only supported commands are sent to the module.
Error LED flashes continuously	NBAA is OK, no response from the drive on fiber link	Power on the drive. Check the fiber link wiring.
All LEDs flash continuously at the same time	Watchdog time out	Hardware failure on NBAA module. Switch power off and on; if the problem persists, replace the NBAA module.
XMIT, REC, and ERROR LEDs on	ROM checksum test failed	Hardware failure. Replace NBAA.
REC and ERROR LEDs on	RAM test failed	Hardware failure. Replace NBAA.
ERROR LED on	DDCS ASIC register access test failed	Hardware failure. Replace NBAA.
Continuous re-boot	Drive configuration write failed	Incorrect drive firmware. Change the downloaded drive application. Contact an ABB representative.

Appendix A – FLN Points

The tables below show the FLN LAN points for different ABB drives.

Table A-1 FLN LAN points for ACS600, application 2723

Pnt	Descriptor	Type	Engr. Units (SI Units)	Slope (SI Units)	Intercept (SI Units)	In EE-prom	Range
				On Text	Off Text		
1	CTRL ADDRESS	LAO	--	1	0	Yes	0-98
2	APPLICATION	LAO	--	1	0	--	2723
{3}	FREQ OUTPUT	LAI	HZ	0.01	0	--	0-300
{4}	PCT OUTPUT	LAI	PCT	0.005	0	--	0-100
{5}	SPEED	LAI	RPM	1	0	--	0-18000
{6}	CURRENT	LAI	A	0.1	0	--	0-3276
{7}	TORQUE	LAI	PCT	0.1	-300	--	0-300
{8}	POWER	LAI	PCT	0.1	0	--	0-300
{9}	DRIVE TEMP	LAI	DEG F (DEG C)	1.8 (1)	32 (0)	--	32-257 (0-125)
{10}	MWH	LAI	MWH	0.1	0	--	0-3676
{12}	RUN TIME	LAI	HRS	1	0	--	0-36767
{13}	DC BUS VOLT	LAI	V	1	0	--	0-1200
20	OVRD TIME	LAO	HRS	1	0	--	0-255
{21}	FWD.REV	LDI	--	REV	FWD	--	0-1
{22}	CMD FWD.REV	LDO	--	REV	FWD	--	0-1
{23}	STOP.RUN	LDI	--	RUN	STOP	--	0-1

Pnt	Descriptor	Type	Engr. Units (SI Units)	Slope (SI Units)	Intercept (SI Units)	In EE-prom	Range
				On Text	Off Text		
{24}	CMD STP.STRT	LDO	--	START	STOP	--	0-1
{25}	EXT1.EXT2	LDI	--	EXT2	EXT1	--	0-1
{26}	HAND AUTO	LDI	--	AUTO	HAND	--	0-1
29	DAY.NIGHT	LDO	--	NIGHT	DAY	--	0-1
30	CURRENT LIM	LAO	PCT	0.01	0	Yes	0-200
31	ACCEL TIME 1	LAO	SEC	0.1	0	Yes	0-1800
32	DECEL TIME 1	LAO	SEC	0.1	0	Yes	0-1800
33	LOCK PANEL	LDO	--	LOCK	OPEN	Yes	0-1
{34}	SEL EXT1.2	LDO	--	EXT2	EXT1	--	0-1
{35}	RUN ENABLE	LDO	--	ON	OFF	--	0-1
{40}	CMD DRV RO 1	LDO	--	ON	OFF	--	0-1
{41}	CMD DRV RO 2	LDO	--	ON	OFF	--	0-1
{42}	CMD DRV RO 3	LDO	--	ON	OFF	--	0-1
{43}	DRV ACT AO 1	LAI	MA	0.001	0	--	0-20
{44}	DRV ACT AO 2	LAI	MA	0.001	0	--	0-20
{45}	DRV ACT AI 1	LAI	V	0.001	0	--	0-10
{46}	DRV ACT AI 2	LAI	MA	0.001	0	--	0-20
{47}	DRV ACT AI 3	LAI	MA	0.001	0	--	0-20
{48}	CMDDRVAO 1	LAO	PCT	0.005	0	--	0-100
{49}	CMDDRVAO 2	LAO	PCT	0.005	0	--	0-100
{50}	INPUT REF 1	LAO	HZ	0.005	0	--	0-100
{51}	INPUT REF 2	LAO	PCT	0.005	0	--	0-100

Pnt	Descriptor	Type	Engr. Units (SI Units)	Slope (SI Units)	Intercept (SI Units)	In EE-prom	Range
				On Text	Off Text		
{60}	PID FEEDBACK	LAI	PCT	0.01	0	--	0-100
61	PID GAIN	LAO	PCT	0.01	0.1	Yes	0.1-100
62	PID I TIME	LAO	SEC	0.01	0.02	Yes	0.02-320
63	PID D TIME	LAO	SEC	0.01	0	Yes	0-10
64	PID D FILTER	LAO	SEC	0.01	0.04	Yes	0.04-10
{70}	DRV ACT DI 1	LDI	--	ON	OFF	--	0-1
{71}	DRV ACT DI 2	LDI	--	ON	OFF	--	0-1
{72}	DRV ACT DI 3	LDI	--	ON	OFF	--	0-1
{73}	DRV ACT DI 4	LDI	--	ON	OFF	--	0-1
{74}	DRV ACT DI 5	LDI	--	ON	OFF	--	0-1
{75}	DRV ACT DI 6	LDI	--	ON	OFF	--	0-1
{76}	DRV ACT RO 1	LDI	--	ON	OFF	--	0-1
{77}	DRV ACT RO 2	LDI	--	ON	OFF	--	0-1
{78}	DRV ACT RO 3	LDI	--	ON	OFF	--	0-1
{90}	FAULT WORD 1	LAI	--	1	0	--	0-16
{91}	FAULT WORD 2	LAI	--	1	0	--	0-16
{92}	SYSTEM FAULT	LAI	--	1	0	--	0-16
{93}	OK.FAULT	LDI	--	FAULT	OK	--	0-16
{94}	RESET FAULT	LDO	--	RESET	NO	--	0-16
99	ERROR STATUS	LAI	--	1	0	--	0-255

Table A-2 FLN LAN points for ACH400, application 2724

Pnt	Descriptor	Type	Engr. Units (SI Units)	Slope (SI Units) On Text	Intercept (SI Units) Off Text	In EE-prom	Range
1	CTRL ADDRESS	LAO	--	1	0	Yes	0-98
2	APPLICATION	LAO	--	1	0	--	2724
{3}	FREQ OUTPUT	LAI	HZ	0.1	0	--	0-250
{4}	PCT OUTPUT	LAI	PCT	0.01	0	--	0-100
{5}	SPEED	LAI	RPM	1	0	--	0-9999
{6}	CURRENT	LAI	A	0.1	0	--	0-9999
{7}	TORQUE	LAI	PCT	0.1	-300	--	0-300
{8}	POWER	LAI	KW	0.1	0	--	0-9999
{9}	DRIVE TEMP	LAI	DEGF (DEG C)	0.18 (0.1)	32 (0)	--	0-302 (0-150)
{10}	KWH	LAI	KWH	1	0	--	0-9999
{11}	MWH	LAI	MWH	0.1	0	--	0-999
{12}	RUN TIME	LAI	HRS	1	0	--	0-9999
{13}	DC BUS VOLT	LAI	V	0.1	0	--	0-999
20	OVRD TIME	LAO	HRS	1	0	--	0-255
{21}	FWD.REV	LDI	--	REV	FWD	--	0-1
{22}	CMD FWD.REV	LDO	--	REV	FWD	--	0-1
{23}	STOP.RUN	LDI	--	RUN	STOP	--	0-1
{24}	CMD STP.STRT	LDO	--	START	STOP	--	0-1
{25}	EXT1.EXT2	LDI	--	EXT2	EXT1	--	0-1
{26}	HAND AUTO	LDI	--	AUTO	HAND	--	0-1
29	DAY.NIGHT	LDO	--	NIGHT	DAY	--	0-1
30	CURRENT LIM	LAO	A	0.1	0	Yes	0.5*In-1.66*In

Pnt	Descriptor	Type	Engr. Units (SI Units)	Slope (SI Units) On Text	Intercept (SI Units) Off Text	In EE-prom	Range
31	ACCEL TIME 1	LAO	SEC	0.1	0.1	Yes	0.1-1800
32	DECEL TIME 1	LAO	SEC	0.1	0.1	Yes	0.1-1800
33	LOCK PANEL	LDO	--	LOCK	OPEN	Yes	0-1
{34}	SEL EXT1.2	LDO	--	EXT2	EXT1	--	0-1
{35}	RUN ENABLE	LDO	--	ON	OFF	--	0-1
{40}	CMD DRV RO 1	LDO	--	ON	OFF	--	0-1
{41}	CMD DRV RO 2	LDO	--	ON	OFF	--	0-1
{43}	DRV ACT AO 1	LAI	MA	0.1	0	--	0-20
{45}	DRV ACT AI 1	LAI	PCT	0.1	0	--	0-100
{46}	DRV ACT AI 2	LAI	PCT	0.1	0	--	0-100
{48}	CMD DRV AO 1	LAO	PCT	0.5	0	--	0-100
{50}	INPUT REF 1	LAO	PCT	0.005	0	--	0-100
{51}	INPUT REF 2	LAO	PCT	0.01	0	--	0-100
{60}	PID FEEDBACK	LAI	PCT	0.1	0	--	0-100
61	PID GAIN	LAO	PCT	0.1	0.1	Yes	0.1-100
62	PID I TIME	LAO	SEC	0.1	0.1	Yes	0.1-320
63	PID D TIME	LAO	SEC	0.1	0	Yes	0-10
64	PID D FILTER	LAO	SEC	0.1	0	Yes	0-10
{70}	DRV ACT DI 1	LDI	--	ON	OFF	--	0-1
{71}	DRV ACT DI 2	LDI	--	ON	OFF	--	0-1
{72}	DRV ACT DI 3	LDI	--	ON	OFF	--	0-1
{73}	DRV ACT DI 4	LDI	--	ON	OFF	--	0-1
{74}	DRV ACT DI 5	LDI	--	ON	OFF	--	0-1
{76}	DRV ACT RO 1	LDI	--	ON	OFF	--	0-1

Pnt	Descriptor	Type	Engr. Units (SI Units)	Slope (SI Units) On Text	Intercept (SI Units) Off Text	In EE-prom	Range
{77}	DRV ACT RO 2	LDI	--	ON	OFF	--	0-1
{90}	LAST FAULT	LAI	--	1	0	--	0-255
{91}	PREV FAULT	LAI	--	1	0	--	0-255
{92}	OLDEST FAULT	LAI	--	1	0	--	0-255
{93}	OK.FAULT	LDI	--	FAULT	OK	--	0-1
{94}	RESET FAULT	LDO	--	RESET	NO	--	0-1
99	ERROR STATUS	LAI	--	1	0	--	0-255

NOTE: To command ACH400 Analog and Relay Outputs via FLN, the following settings are required:

- Relay Output 1: Set parameter 1401 to 7 “SUPERV1 OVER”, set parameter 3201 to 131 (SERIAL LINK DATA1) and set parameter 3203 to 1.
- Relay Output 2: Set parameter 1402 to 7 “SUPERV2 OVER”, set parameter 3204 to 132 (SERIAL LINK DATA 2) and set parameter 3206 to 1.
- Analogue Output: Set parameter 1501 to 133 (SERIAL LINK DATA 3) and set parameter 1503 to 255.

Appendix B – N2 Points

This chapter lists all the I/O points defined for compatible ABB drives. This chapter is intended for reference purposes.

All the numbers read and written to the drive are in engineering units.

Parameters

The following table lists all of the I/O points. For each point, the following information is provided:

- The Point type
- The Point number
- Engineering units
- Allowable range of values

Appendix B – N2 Points

Table A-1 N2 points for ACS600

Numb	Point	Units	Range
Analog Inputs:			
1	OUTPUT FRE-	Hz	0 - 300
2	RATED SPEED	%	0 – 100
3	SPEED	rpm	0 – 65535
4	CURRENT	A	0.0 – 6553.5
5	RATED TORQUE	%	-300 – 300
6	RATED POWER	%	-300 – 300
7	DRIVE TEMPERA-	°C	0 – 125
8	MEGAWATT	MWh	0 – 3635
9	RUN TIME	h	0 – 65,535
10	DC BUS VOLT-	V	0 – 1200
11	PID-CTRL ACT	%	0 – 100
12	FAULT WORD 1		fault code
13	FAULT WORD 2		fault code
14	SYSTEM FAULT		fault code
15	AI 1 ACTUAL	V	0 - 10
16	AI 2 ACTUAL	mA	0 - 20
17	AI 3 ACTUAL	mA	0 - 20
18	AO 1 ACTUAL	mA	0 - 20
19	AO 2 ACTUAL	mA	0 - 20

Table continues on Next Page

Numb	Point	Units	Range
Binary Inputs:			
1	STOP/RUN		0 = Stop, 1 = Drive Run-
2	FWD/REV		0 = Forward, 1 = Reverse
3	OK/FAULT		0 = OK, 1 = Drive Faulted
4	RELAY OUTPUT 1		0 = off, 1 = on
5	RELAY OUTPUT 2		0 = off, 1 = on
6	RELAY OUTPUT 3		0 = off, 1 = on
7	DIGITAL INPUT 1		0 = off, 1 = on
8	DIGITAL INPUT 2		0 = off, 1 = on
9	DIGITAL INPUT 3		0 = off, 1 = on
10	DIGITAL INPUT 4		0 = off, 1 = on
11	DIGITAL INPUT 5		0 = off, 1 = on
12	DIGITAL INPUT 6		0 = off, 1 = on
13	EXT1/EXT2		0 = Ext1, 1 = Ext2
14	HAND/AUTO		0 = Hand, 1 = Auto

Table continues on Next Page

Appendix B – N2 Points

Numb	Point	Units	Range
Analog Outputs:			
1	REFERENCE 1	%	0 - 100
2	REFERENCE 2	%	0 – 100
3	CURRENT LIMIT	%	0 – 200
4	ACCEL TIME 1	s	0 – 1800
5	DECEL TIME 1	s	0 – 1800
6	PID-CONT GAIN	%	0.1 – 100
7	PID-CONT I-TIME	s	0.2 – 320
8	PID-CONT D-TIME	s	0 - 10
9	PID-CONT D FIL-	s	0.04 - 10
10	COMMAND AO 1	%	0 – 100
11	COMMAND AO 2	%	0 – 100
Binary Outputs:			
1	STOP/START		0 = Stop, 1 = Start to
2	FORWARD/		0 = Forward, 1 = Reverse
3	PANEL LOCK		0 = Open, 1 = Locked
4	RUN ENABLE		0 = Off, 1 = On
5	REF1/REF2		0 = Ref1, 1 = Ref2
6	FAULT RESET		Change 0 -> 1 Resets
7	COMMAND RO 1		0 = Off, 1 = On
8	COMMAND RO 2		0 = Off, 1 = On
9	COMMAND RO 3		0 = Off, 1 = On

Table A-2 N2 points for ACH400

Numb	Point	Units	Range
Analog Inputs:			
1	OUTPUT FRE-	Hz	0 - 250
2	RATED SPEED	%	0 – 100
3	SPEED	rpm	0 – 9999
4	CURRENT	A	0 – 9999
5	RATED TORQUE	%	-300 – 300
6	RATED POWER	kW	0 -9999
7	DRIVE TEMPERA-	°C	0 – 125
8	KILOWATT	kWh	0 – 9999
9	MEGAWATT	MWh	0 – 999
10	RUN TIME	h	0 – 9999
11	DC BUS VOLTAGE	V	0 – 999
12	PID-CTRL ACT	%	0 – 100
13	LAST FAULT		fault code
14	PREV FAULT		fault code
15	OLDEST FAULT		fault code
16	AI 1 ACTUAL	%	0 - 100
17	AI 2 ACTUAL	%	0 - 100
18	AO 1 ACTUAL	mA	0 - 20

Table continues on Next Page

Appendix B – N2 Points

Numb	Point	Units	Range
Binary Inputs:			
1	STOP/RUN		0 = Stop, 1 = Drive Run-
2	FWD/REV		0 = Forward, 1 = Reverse
3	OK/FAULT		0 = OK, 1 = Drive Faulted
4	RELAY OUTPUT 1		0 = off, 1 = on
5	RELAY OUTPUT 2		0 = off, 1 = on
6	DIGITAL INPUT 1		0 = off, 1 = on
7	DIGITAL INPUT 2		0 = off, 1 = on
8	DIGITAL INPUT 3		0 = off, 1 = on
9	DIGITAL INPUT 4		0 = off, 1 = on
10	DIGITAL INPUT 5		0 = off, 1 = on
11	EXT1/EXT2		0 = Ext1, 1 = Ext2
12	HAND/AUTO		0 = Hand, 1 = Auto

Table continues on Next Page

Numb	Point	Units	Range
Analog Outputs:			
1	REFERENCE 1	%	0 - 100
2	REFERENCE 2	%	0 – 100
3	CURRENT LIMIT	A	0.5*In - 1.66*In
4	ACCEL TIME 1	s	0.1 – 1800
5	DECEL TIME 1	s	0.1 – 1800
6	PID-CONT GAIN	%	0.1 – 100
7	PID-CONT I-TIME	s	0.1 – 320
8	PID-CONT D-TIME	s	0 - 10
9	PID-CONT D FIL-	s	0 - 10
10	COMMAND AO 1	%	0 – 100
Binary Outputs:			
1	STOP/START		0 = Stop, 1 = Start to
2	FORWARD/		0 = Forward, 1 = Reverse
3	PANEL LOCK		0 = Open, 1 = Locked
4	RUN ENABLE		0 = Off, 1 = On
5	REF1/REF2		0 = Ref1, 1 = Ref2
6	FAULT RESET		Change 0 -> 1 Resets
7	COMMAND RO 1		0 = Off, 1 = On
8	COMMAND RO 2		0 = Off, 1 = On

NOTE: To command ACH400 Analog and Relay Outputs via N2, the following settings are required:

- Relay Output 1: Set parameter 1401 to 7 “SUPERV1 OVER”, set parameter 3201 to 131 (SERIAL LINK DATA1) and set parameter 3203 to 1.
- Relay Output 2: Set parameter 1402 to 7 “SUPERV2 OVER”, set parameter 3204 to 132 (SERIAL LINK DATA 2) and set parameter 3206 to 1.
- Analog Output: Set parameter 1501 to 133 (SERIAL LINK DATA 3) and set parameter 1503 to 255.

Appendix B – N2 Points

This section lists the Data Definition Language files for ABB drives to be used with the NCU (Network Controller Unit).

This section is intended for people who are defining the I/O points of the ABB drive to the Network Controller Units.

ACS 600.DDL

ABB Standard Drives, ACS 600 Variable Frequency Drive

CSMODEL "ACS_600","VND"

AITITLE "Analog Inputs"

BITITLE "Binary Inputs"

AOTITLE "Analog Outputs"

BOTITLE "Binary Outputs"

CSAI "AI1",N,N,"FREQ ACT","Hz"

CSAI "AI2",N,N,"PCT ACT","%"

CSAI "AI3",N,N,"SPEED","RPM"

CSAI "AI4",N,N,"CURRENT","A"

CSAI "AI5",N,N,"TORQUE","%"

CSAI "AI6",N,N,"POWER","kW"

CSAI "AI7",N,N,"DRV TEMP","C"

CSAI "AI8",N,N,"ENERGY M","Mwh"

CSAI "AI9",N,N,"HOURS","h"

CSAI "AI10",N,N,"DC VOLT","V"

CSAI "AI11",N,N,"PID ACT","%"

CSAI "AI12",N,N,"FLT WRD1","Code"

CSAI "AI13",N,N,"FLTWRD2","Code"

CSAI "AI14",N,N,"SYST FLT","Code"

CSAI "AI15",N,N,"AI 1","V"

CSAI "AI16",N,N,"AI 2","mA"

CSAI "AI17",N,N,"AI 3","mA"

CSAI "AI18",N,N,"AO 1","mA"

CSAI "AI19",N,N,"AO 2","mA"

CSBI "BI1",N,N,"STATUS","STOP","RUN"

CSBI "BI2",N,N,"DIRECT.,"FWD","REV"

CSBI "BI3",N,N,"FAULT","OK","FLT"

CSBI "BI4",N,N,"RO 1","OFF","ON"

Appendix B – N2 Points

CSBI "BI5",N,N,"RO 2","OFF","ON"
CSBI "BI6",N,N,"RO 3","OFF","ON"
CSBI "BI7",N,N,"DI 1","OFF","ON"
CSBI "BI8",N,N,"DI 2","OFF","ON"
CSBI "BI9",N,N,"DI 3","OFF","ON"
CSBI "BI10",N,N,"DI 4","OFF","ON"
CSBI "BI11",N,N,"DI 5","OFF","ON"
CSBI "BI12",N,N,"DI 6","OFF","ON"
CSBI "BI13",N,N,"EXT 1/2","EXT1","EXT2"
CSBI "BI14",N,N,"HAND/AUTO","HAND","AUTO"

CSAO "AO1",Y,Y,"REF 1","%"
CSAO "AO2",Y,Y,"REF 2","%"
CSAO "AO3",Y,Y,"CURR LIM","%"
CSAO "AO4",Y,Y,"ACCEL 1","s"
CSAO "AO5",Y,Y,"DECEL 1","s"
CSAO "AO6",Y,Y,"PID GAIN","%"
CSAO "AO7",Y,Y,"PID ITIM","s"
CSAO "AO8",Y,Y,"PID DTIM","s"
CSAO "AO9",Y,Y,"PID DFIL","s"
CSAO "AO10",Y,Y,"CMD AO 1","%"
CSAO "AO11",Y,Y,"CMD AO 2","%"

CSBO "BO1",Y,Y,"START","STOP","START"
CSBO "BO2",Y,Y,"REVERSE","FWD","REV"
CSBO "BO3",Y,Y,"PAN LOCK","OPEN","LOCKED"
CSBO "BO4",Y,Y,"RUN ENAB","DISABLE","ENABLE"
CSBO "BO5",Y,Y,"R1/2 SEL","EXT 1","EXT 2"
CSBO "BO6",Y,Y,"FLT RSET","-","RESET"
CSBO "BO7",Y,Y,"CMD DO 1","OFF","ON"
CSBO "BO8",Y,Y,"CMD DO 2","OFF","ON"
CSBO "BO9",Y,Y,"CMD DO 3","OFF","ON"

ACH 400.DDL

```
*****  
ABB Standard Drives, ACH 400 Variable Frequency  
Drive  
*****  
CSMODEL "ACH_400","VND"  
  
AITITLE "Analog Inputs"  
BITITLE "Binary Inputs"  
AOTITLE "Analog Outputs"  
BOTITLE "Binary Outputs"  
  
CSAI "AI1",N,N,"FREQ ACT","Hz"  
CSAI "AI2",N,N,"PCT ACT","%"  
CSAI "AI3",N,N,"SPEED","RPM"  
CSAI "AI4",N,N,"CURRENT","A"  
CSAI "AI5",N,N,"TORQUE","%"  
CSAI "AI6",N,N,"POWER","kW"  
CSAI "AI7",N,N,"DRV TEMP","C"  
CSAI "AI8",N,N,"ENERGY k","kWh"  
CSAI "AI9",N,N,"ENERGY M","Mwh"  
CSAI "AI10",N,N,"HOURS","h"  
CSAI "AI11",N,N,"DC VOLT","V"  
CSAI "AI12",N,N,"PID ACT","%"  
CSAI "AI13",N,N,"LAST FLT","Code"  
CSAI "AI14",N,N,"2ND FLT","Code"  
CSAI "AI15",N,N,"1ST FLT","Code"  
CSAI "AI16",N,N,"AI 1","%"  
CSAI "AI17",N,N,"AI 2","%"  
CSAI "AI18",N,N,"AO 1","mA"  
  
CSBI "BI1",N,N,"STATUS","STOP","RUN"  
CSBI "BI2",N,N,"DIRECT.,"FWD","REV"  
CSBI "BI3",N,N,"FAULT","OK","FLT"  
CSBI "BI4",N,N,"RO 1","OFF","ON"  
CSBI "BI5",N,N,"RO 2","OFF","ON"  
CSBI "BI6",N,N,"DI 1","OFF","ON"  
CSBI "BI7",N,N,"DI 2","OFF","ON"  
CSBI "BI8",N,N,"DI 3","OFF","ON"  
CSBI "BI9",N,N,"DI 4","OFF","ON"  
CSBI "BI10",N,N,"DI 5","OFF","ON"
```

Appendix B – N2 Points

CSBI "BI11",N,N,"EXT 1/2","EXT1","EXT2"

CSBI "BI12",N,N,"HAND/AUTO","HAND","AUTO"

CSAO "AO1",Y,Y,"REF 1","%"

CSAO "AO2",Y,Y,"REF 2","%"

CSAO "AO3",Y,Y,"CURR LIM","A"

CSAO "AO4",Y,Y,"ACCEL 1","s"

CSAO "AO5",Y,Y,"DECEL 1","s"

CSAO "AO6",Y,Y,"PID GAIN","%"

CSAO "AO7",Y,Y,"PID ITIM","s"

CSAO "AO8",Y,Y,"PID DTIM","s"

CSAO "AO9",Y,Y,"PID DFIL","s"

CSAO "AO10",Y,Y,"CMD AO 1","%"

CSBO "BO1",Y,Y,"START","STOP","START"

CSBO "BO2",Y,Y,"REVERSE","FWD","REV"

CSBO "BO3",Y,Y,"PAN LOCK","OPEN","LOCKED"

CSBO "BO4",Y,Y,"RUN

ENAB","DISABLE","ENABLE"

CSBO "BO5",Y,Y,"R1/2 SEL","EXT 1","EXT 2"

CSBO "BO6",Y,Y,"FLT RSET","-","RESET"

CSBO "BO7",Y,Y,"CMD DO 1","OFF","ON"

CSBO "BO8",Y,Y,"CMD DO 2","OFF","ON"

Appendix C – Technical Data

DDCS Link

Compatible Devices: All ABB Fieldbus Adapter modules, ABB ACS 600, ACS/ACH 400 Drives

Size of the Link: 2 stations

Medium: Fiber optic cable

- Construction: Plastic core, 1 mm diameter, sheathed with plastic jacket
- Attenuation: 0.31 dB/m
- Maximum Length between Stations: 10m
- Specifications:

Parameter	Minimum	Maximum	Unit
Storage Temperature	-55	+85	°C
Installation Temperature	-20	+70	°C
Short Term Tensile Force		50	N
Short Term Bend Radius	25		mm
Long Term Bend Radius	35		mm
Long Term Tensile Load		1	N
Flexing		1000	cycles

Topology: Point-to-point

Serial Communication Type: Synchronous, half Duplex

Transfer Rate: 4 Mbit/s

Protocol: Distributed Drives Communication System (DDCS)

Connectors: Blue – receiver; grey – transmitter

Appendix C – Technical Data

Fieldbus Link

Compatible Devices: All devices are compatible with the FLN and N2 protocols

Size of the Link: 99 (FLN) or 255 (N2) stations with repeaters (32 stations per segment)

Medium: Shielded, twisted pair RS485 cable

Termination: Resistors are built into the NBAA-01 Module

Topology: Multi-drop

Serial Communication Type: Asynchronous, half Duplex

Transfer Rate: 1200, 2400, 4800, 9600, or 19200 bit/s

Protocol: FLN or N2

NBAA-01

Enclosure: Plastic, dimensions 45 × 75 × 105 mm; IP 20 degree of protection

Mounting: Standard DIN mounting rail

Settings: Via drive interface (control panel)

Current Consumption: 80 mA at 24 VDC

Connectors:

- Light transmitter (grey) and receiver (blue) for connection to the drive
- One Combicon MVSTBW 2,5/8-ST-5,08 (8-pole, cross-section 2.5 mm² max.) screw terminal block for the fieldbus and power supply:

X2		Description
1	D(P)	D(P) = B = Data Positive (Conductor 1 in twisted pair) D(N) = A = Data Negative (Conductor 2 in twisted pair) DG = Data Ground
2	D(N)	
3	DG	
4	SHF	Cable shield AC grounding (via an RC filter)
5	SH	Cable shield grounding (directly grounded)
6	0V	Power supply for the module (24 VDC ± 10 %); shielded cable.
7	+24 V	
8	PE	Ground

General:

- All materials are UL/CSA approved
- Complies with EMC Standards EN 50081-2 and EN 50082-2

Appendix D – Installation Check-list

This chapter has an installation check-list. The drive's programming depends on how the Landis & Staefa System 600 is controlling the drive.

Table D-1 Check-list

Item	Ref 1 (Hand)	Ref 2 (Auto)	Done
LAN address	<input type="checkbox"/> _ _ _ _		<input type="checkbox"/>
Start / Stop	<input type="checkbox"/> Digital I/O <input type="checkbox"/> System 600 <input type="checkbox"/> Other	<input type="checkbox"/> Digital I/O <input type="checkbox"/> System 600 <input type="checkbox"/> Other	<input type="checkbox"/>
Reference	<input type="checkbox"/> Analog I/O <input type="checkbox"/> System 600 <input type="checkbox"/> Other	<input type="checkbox"/> Analog I/O <input type="checkbox"/> System 600 <input type="checkbox"/> Other	<input type="checkbox"/>
Control Mode (Ref1/Ref2)	<input type="checkbox"/> Digital I/O <input type="checkbox"/> System 600 <input type="checkbox"/> Other		<input type="checkbox"/>
Panel Lock	<input type="checkbox"/> System 600 <input type="checkbox"/> Other		<input type="checkbox"/>
Run Enable	<input type="checkbox"/> Digital I/O <input type="checkbox"/> System 600 <input type="checkbox"/> Other		<input type="checkbox"/>
Fault Reset	<input type="checkbox"/> Digital I/O <input type="checkbox"/> System 600 <input type="checkbox"/> Other		<input type="checkbox"/>
Control	<input type="checkbox"/> Speed	<input type="checkbox"/> %-Reference <input type="checkbox"/> PI Control	<input type="checkbox"/>

Some of the settings are common for both Reference 1 and Reference 2 control modes of ABB drive.

Appendix D – Installation Check-list

Appendix E – Ambient Conditions

Ambient Conditions, Operation

Ambient operating conditions refer to the conditions the option module is subjected to when installed for stationary use.

Air Temperature: 0 to +50 °C

Relative Humidity: 5 to 95 %, no condensation allowed. Maximum allowed relative humidity is 60 % in the presence of corrosive gases.

Contamination Levels:

Chemical gases: IEC 721-3-3, Class 3C2

Solid particles: IEC 721-3-3, Class 3S2

Installation Site Altitude: 0 to 2000 m. If installation site is above 2000 m, contact your local ABB representative.

Vibration: Max 0.3 mm (2 to 9 Hz), max 1 m/s² (9 to 200 Hz) sinusoidal (IEC 68-2-6)

Shock: Max 70 m/s², 22 ms (IEC 68-2-27)

Ambient Conditions, Storage

Ambient storage conditions refer to the conditions the option module is subjected to during storage in the protective package.

Temperature: -40 to +70 °C.

Relative Humidity: Less than 95 %, no condensation allowed

Atmospheric Pressure: 70 to 106 kPa

Vibration: Max 0.3 mm (2 to 9 Hz), max 1 m/s² (9 to 200 Hz) sinusoidal (IEC 68-2-6)

Shock: Max 100 m/s², 11 ms (IEC 68-2-27)

Appendix E – Ambient Conditions

Ambient Conditions, Transportation

Ambient transportation conditions refer to the conditions the option module is subjected to during transportation in the protective package.

Temperature: -40 to +70 °C

Relative Humidity: Less than 95 %, no condensation allowed.

Atmospheric Pressure: 60 to 106 kPa

Vibration: Max 3.5 mm (2 to 9 Hz), max 15 m/s² (9 to 200 Hz) sinusoidal (IEC 68-2-6)

Shock: Max 100 m/s², 11 ms (IEC 68-2-27)

Bump: Max 300 m/s², 6 ms (IEC 68-2-29)

Free Fall: 250 mm



ABB Inc.
Drives
16250 West Glendale Drive
New Berlin, WI 53151
USA
Telephone: 262 785-8378
800 243-4384
Fax: 262 780-5135
Internet: www.abb-drives.com

ABB Oy
AC Drives
P.O.Box 184
FIN-00381 Helsinki
FINLAND
Telephone: +358 10 222 000
Fax: +358 10 222 2681
Internet: www.abb.com

NBAA-US-04 (NBAA-01/EN)
3AJA489002B5248 R0101 REV D
(3BFE 64307576 R0125 REV D)
Effective: 3/1/02
Supersedes: 3/1/00