

New marine propulsion concept with booster motor

Three US container ships were upgraded at the Hamburg shipyard of Blohm + Voss GmbH by shortening the vessels and installing a new marine propulsion system. The innovative drive system, which has an ABB motor and generator, has boosted the speed of the ships considerably. Instead of 'power take off', it makes use of the 'power take in' concept to transmit electrical energy to the main shaft. ABB Industrietechnik AG supplied the complete 4-MW electrical booster plants as well as the electrical equipment for the bow thrusters.

Operators of container ships have had to adjust to a vastly changed situation in recent years. The need today is for faster, smaller container vessels with a capacity of 2,500 to 6,000 TEU (equivalent unit for 20-foot containers) and able to travel at a speed of at least 21 knots.

Modernization of ECON ships

Recognizing the trend, the *Sea-Land Division* of *CSX Corporation* in the USA began looking for ways to modernize its large and relatively slow container ships. These were built in Korea in the early 1980s as so-called ECON ships for United States Lines (USL).

The vessels, which when new were among the most economical container ships in service, originally had a storage capacity of approximately 3,900 TEU and a speed of 18 knots. USL operated the ships as Atlantic Class Vessels (ACV). *Table 1* shows their as-built dimensions.

Ten years later, speed had become the dominating factor for these vessels, with large container capacities given only a second priority [2]. The most obvious way to increase the speed of the ships

was to reduce their length by three hatch groups and to equip each of them with a new forebody and afterbody plus a new propulsion plant. The idea, however, was rejected as being economically unviable.

Alternative solutions also fell through as they could not be fitted into time schedules, for example, for the construction of new parts in other countries.

SL-31 – a brand new concept

The shipyard and shipowner eventually agreed on a completely new concept. The project name that was chosen was SL-31 (SL stands for Sea-Land, 3 for 3,000 TEU and 1 for 21 knots) [1]. It proposed a reduction in the length of the ACV container ships by three hatch

groups, a more streamlined forebody and a higher power rating for the propeller. Extensive calculations and tests were carried out by the shipyard at the marine test institute HSVA in Hamburg to make sure that the higher speed of 21 knots would actually be achieved. An increase in the drive power rating would be necessary in any case, as would modifications to the shape of the forebody. The dimensions of the shortened container ship are also given in *Table 1*.

The changes that had to be made to the body of the ship called for precision work of a kind that could only be carried out by a shipyard as experienced as Blohm + Voss GmbH. For example, during removal of the midbody (with three hatch groups) a flame-cut with a length of 330 m had to be made in one operation and with an accuracy that would ensure that no remachining of the ships' storage structures would be necessary after the forebody and afterbody had been floated back together [2]. In addition, the electrical power connections between the two halves of the ship, involving about 350 cables and large numbers of pipes, had to be separated.

After the midbody had been cut out and temporary bulkheads had been fitted, the forebody and the midbody were floated and pulled out of the dock by tugs. Afterwards, the forebody was moved to within about 300 mm of the afterbody. The dock was then floated again and the forebody pushed up against the afterbody, aligned, tacked, and welded in place. The most critical part of this operation was the maneuvering and alignment of the two halves. Very high precision was necessary, as a deviation of just a few millimeters from the original longitudinal axis would translate into a loss of speed. Optical measuring equipment was used to ensure a perfect fit.

It is worth remembering that the parts being maneuvered weighed several thousand tonnes, and that they had to be

Thomas Fetzberger

Carola Kuhrau

ABB Industrietechnik AG

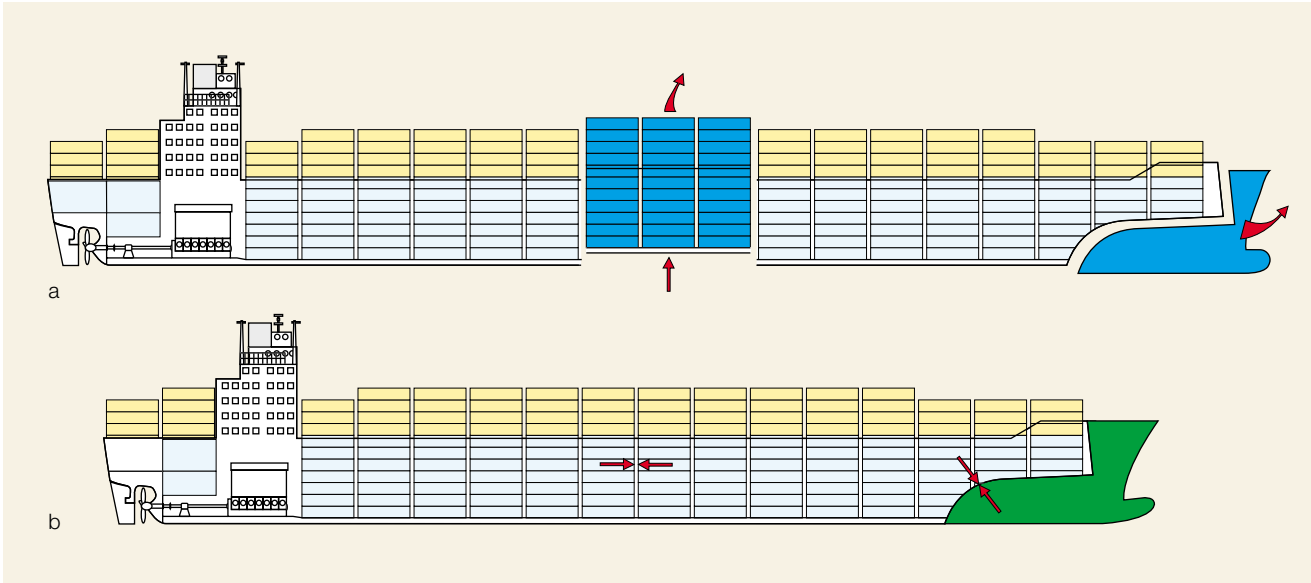

ACV container ship conversion based on the SL-31 concept



a Forebody cut away and mid-body removed

b Shortened ship with new forebody

moved by tugs to precise positions in the dock. This part of the modernization alone was a considerable achievement on the part of the shipyard.

Increasing the drive power

A new approach was also necessary for the upgrade of the container ships' propulsion. The installed machines, Sulzer 7 RLB 90 engines, were rated at 20,590 kW (100%) and 18,530 kW (90%). In order to run the ships at 21 knots without converting the vessels, it would have been necessary to increase the engine power to about 40,000 kW. By streamlining the forebody through hydrodynamic improvements, an initial power saving of 3,700 kW could be achieved **3**. Also, the reduction in length by three hatchgroups reduced the ships' frictional resistance, allowing a further saving of 1,500 kW **4**. Together, these modifications improved the power by 5,200 kW. Therefore, to achieve the required 21 knots in service, an additional 3,800 to 4,000 kW would have to be fed into the propeller shaft system.

Reversal of the conventional shaft generator concept

To raise the drive power rating to the required level, Blohm + Voss GmbH developed a new, unconventional concept that 'reverses' the standard shaft generator system commonly in use. Previously, electrical power has been fed into the on-board power system from the main machine by means of a gear system with attached generator. The new drive makes use of the 'power take in' instead of 'power take off' concept **5**. In this method, 4,000 kW is transmitted via a

6.6-kV electric motor to the main drive shaft by means of tunnel gearing which is flanged via a Vulcan coupling to the flywheel of the main machine **6**, **7**. The electric motor is fed with 4,860 kW (100%) or 4,374 kW (90%) from an additional Wärtsilä-Diesel generator set with 6-MVA alternator of type 12 R 32. The high-voltage switchgear and diesel-generator set are installed in a new engine room on the main deck. Many new, innovative control features were required to link the slow-speed main machine to the electric motor via the tunnel gearing.

Table 1:
Main dimensions and speed of the container ships

	Before conversion Atlantic Class Vessel	After conversion SL-31
Length	279.00 m	248.26 m
Beam	32.20 m	unchanged
Height	21.50 m	unchanged
Draught, full load	11.676 m	unchanged
Speed (draught = 10 m)	18.0 knots	21.0 knots



Sea-Land Pride (formerly Galveston Bay) in Dock 10 after the forebody had been cut away. The midbody is being prepared for removal. 2

Photo: Blohm + Voss GmbH

The power is transmitted to the water by a new KaMeWa controllable pitch propeller with a diameter of 7.1 m. This propeller can absorb up to 24,400 kW, which is also the maximum power transmitted to the shaft. Although the new

propeller is 0.5 m smaller in diameter than the original one, its special shape enables it to produce 20 percent more power. Using the machine data as basis, the propeller power was calculated to be 19,160 kW.

The new forebody is brought into position. 3

Photo: Blohm + Voss GmbH



Tests with a draught of 10 m and a speed of 21 knots showed the power demand to be 18,639 kW, giving a safety margin of 521 kW. Converting this extra power into speed, the maximum speed which is possible is 21.2 knots.

Two alternative concepts for increasing the drive output had also been considered, but were rejected after detailed discussions:

- Two additional diesel-mechanical Z-type propellers with one diesel engine as primary drive system, plus direct transmission of the power via gearing to port and starboard propellers. The two side propellers in this concept would have produced considerable turbulence, influencing the water flow at the main propeller and reducing its efficiency.
- Two diesel-electric drive systems in which each propeller is driven by an electric motor and electrical energy is generated by diesel-generators. This method would have incurred even higher system costs than the first method.

Booster drive system is patented

The concept with the booster drive unites proven components in a completely new way to obtain PTO instead of PTI. The described system has meanwhile been patented [2].

Power transmission to the main shaft has never been realized before in this form. As with many seemingly simple solutions, it was the small details that caused the main problems. A slow-speed diesel engine with oscillating torque had never before been combined with a constant-torque electric motor on a propeller shaft. To protect the electric motor and gearing system from the vibrations caused by the main machine, tunnel gearing was chosen. This transmits the electric motor power via a multi-disc clutch to the gear system and then via



The Sea-Land Pride in Dock 10 after conversion. Next to it, in Dock 11, is the Sea-Land Value.

Photo: Blohm + Voss GmbH

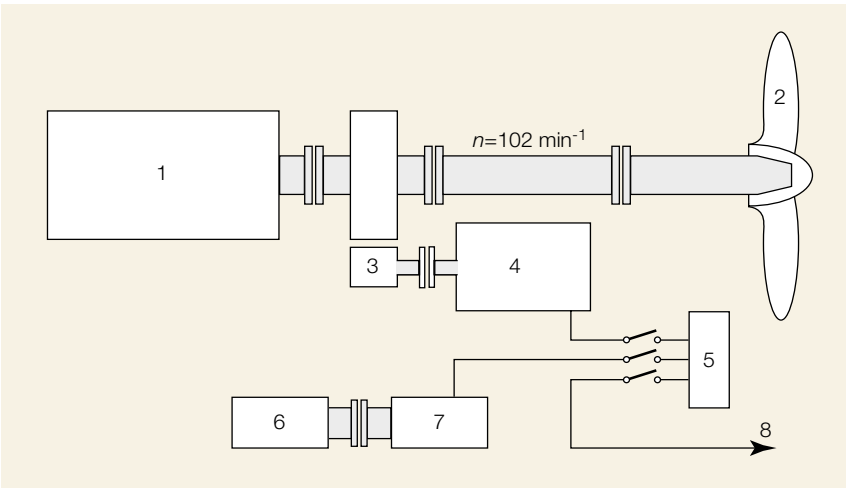

Design of the new marine propulsion system with booster motor

- | | |
|-----------------------------------|------------------------------------|
| 1 Sulzer diesel engine, 20,588 kW | 5 Switchboard, 6.6 kV |
| 2 Controllable-pitch propeller | 6 Wärtsilä diesel engine, 4,860 kW |
| 3 Gearing | 7 Generator, 4,374 kW |
| 4 Booster motor, 4,000 kW | 8 To bow thruster; 1,800 kW |

a Vulcan coupling direct to the flywheel of the main machine and the propeller shaft. The energy flow in the shaft is shown in **3**.

Newly developed control system

To enable the two different systems to be used together, new automatic controls had to be developed for the drive system. These had to ensure functional reliability in every operating mode. This problem alone presented a major challenge, especially in view of the limited time that was available for the development work. For this particular application, a new digital control system of type Woodward 721 was installed.

The new main-machine/booster system was rigorously tested by the US

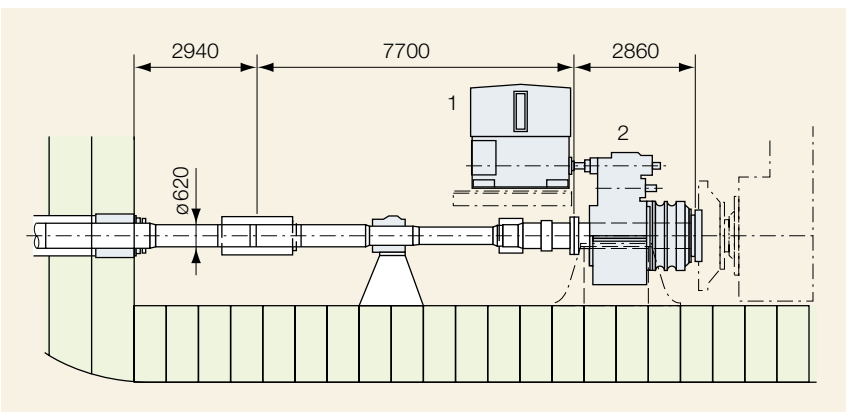

Shaft arrangement for the booster motor and tunnel gearing

- 1 Booster motor
- 2 Tunnel gearing



**Delivery scope
of ABB Industrietechnik AG
(per ship)**

- 1 generator rated 6.6 kV, 6 MVA
- 1 booster motor rated 6.6 kV, 4 MW
- 1 6.6-kV switchboard
- 1 transformer rated 6.6 kV/480 V, 500 kVA
- 1 bow thruster motor rated 6.6 kV, 1.8 MW
- 1 480-V switchboard
- 1 MK II monitoring system, with desk
- Diverse motor starters

Coast Guard (USCG) and the American Bureau of Shipping (ABS) with the help of a Failure Mode Effective Analysis (FMEA). This involved a run-through of all possible service profiles, both in the dock and at sea, to ensure the safety and reliability of the booster system.

The new electrical auxiliary system for the booster installation receives its power from the booster diesel-generator set via a 6,600/480-V, 500-kVA transformer.

Gearing and booster motor

7

Energy flow in the propeller shaft

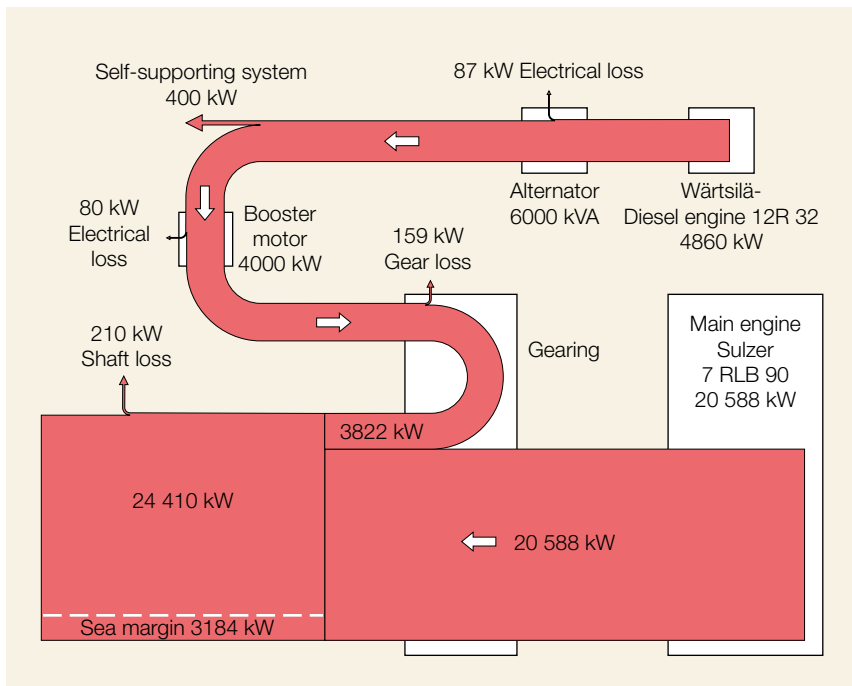

Booster also drives bow thruster

8

Since the booster diesel-generator is not required for docking maneuvers or when the ships are in port, it can also be used to drive the newly installed ABB bow thruster. Thus, the booster diesel-generator has two tasks in that it supplies:

- Additional energy for the main drive (PTI)
- Drive power for the bow thruster

The diesel-generator set supplies power to a 6.6-kV substation with load feeders to the booster motor, the bow thruster and an auxiliary transformer.

For this project, the Marine, Oil and Gas Industry Division of ABB Industrietechnik AG supplied the electrical booster plant **9** **10**, the electrical equipment for the bow thruster and all of the cabling for the electrical systems. During the conversion it was necessary, among other things, to shorten all of the cables to the forebody. This involved cutting a

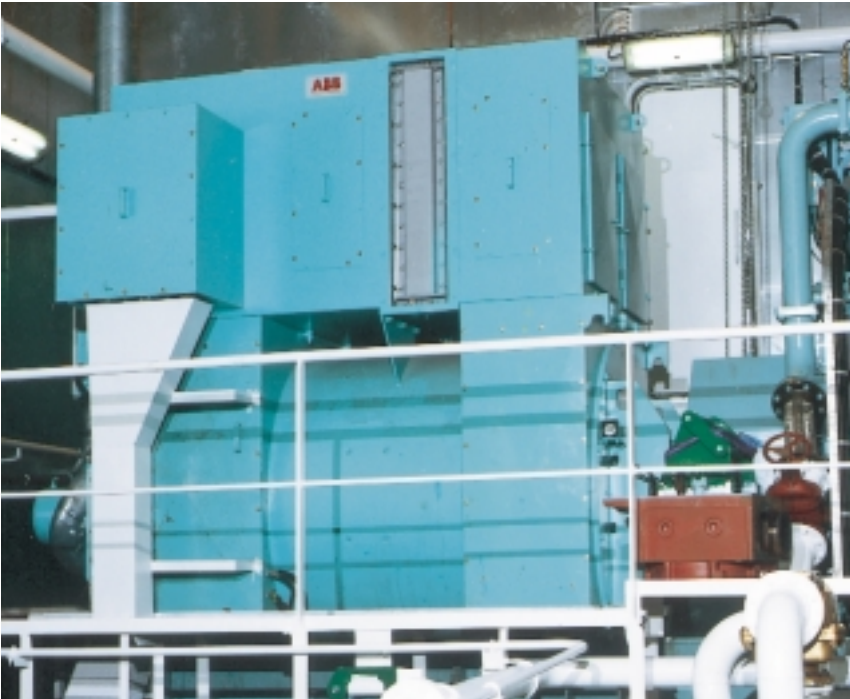

Booster generator

9

Addition to the control desk for operating the booster system

10



40-m-long section out of approximately 350 cables and then reconnecting the cables using heat-shrink joints. The work was carried out in close collaboration with the shipyard and the suppliers of the other systems to ensure full compliance with ABS and USCG regulations.

All objectives were achieved

Sea trials with the first ship to be completed, the Sea-Land Pride (formerly Galveston Bay), were carried out in the summer of 1994 and underscored the success of the project. The vessel, which had been running with a speed of 18 knots, achieved 19 knots without the booster system and almost 22 knots with it. In the same year, its two sister ships, *Sea-Land Value* and *Raleigh Bay*, were also handed over to the customer after successful conversions.

References

- [1] H. M. Meissner: Sea-Land ACV vessel conversion to SL-31. Blohm + Voss, lecture.
- [2] H. M. Meissner, W. D. Wheeler: Sea-Land Atlantic Container Vessel (ACV) conversion to SL-31. Northern California Section of The Society of Naval Architects and Marine Engineers, San Francisco/CA, 16. 2. 1995.

Authors' address

Thomas Fetzberger
 Carola Kuhrau
 ABB Industrietechnik AG
 P.O. box 500 323
 D-22703 Hamburg
 Germany
 Telefax: +49 408 53 45407
 E-mail:
 thomas.fetzberger@deind.mail.abb.com
 carola.kuhrau@deind.mail.abb.com