

TECHNICAL SPECIFICATION

Type designation: NMG 0450CC04
Application: Diesel/Gas Engine Industrial Application Series
Site criteria: Industrial Application

NOTES

CONTENTS

SECTION:

1	PERFORMANCE DATA (Calculated values)	2
2	PERFORMANCE CURVES	3
3	CONFIGURATION AND SCOPE OF SUPPLY	7
4	DIMENSIONS	8

*Type definition:

NMG0450CC04 DBPI

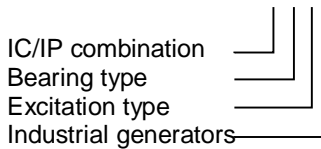

Bearing type: A-Double bearing, B-Single bearing
 Excitation type: A-Auxiliary winding, P-PMG

Prep. PE.YA	24.7.2017	TECHNICAL SPECIFICATION		Valid	No. of sh. 9
Appr. TU.TU	1.8.2017				
Resp. dept. Technique					
ABB	ABB Generators Ltd.	Document identification 8AMG 5903664	Lang. en	Rev. ind. A	Sheet 1

1 PERFORMANCE DATA (Calculated values)

TYPE

Type designation: NMG 0450CC04

PERFORMANCE DATA

Main standard	IEC 60034						
Rated power factor	0.8						
Insulation class	H						
Temperature rise	H						
Ambient temperature	40 °C						
Altitude over sea level	£ 1000 m						
Cooling/Protection	IC0A1/IP23						
Mounting arrangement	Single bearing			Double bearing			
	IM 2105			IM 1001			
Weight	4365 kg			4395 kg			
Inertia	47.6 kgm ²			44.6 kgm ²			
Direction of rotation	CW (Facing drive end)						
Maximum overspeed	2250 rpm						
Winding pitch	Two thirds (2/3)						
Stator winding resistance	0.0008 Ω per phase at 20°C series star connection						
Rotor winding resistance	1.108 Ω at 20°C						
Ex. stator winding resistance	22.873 Ω at 20°C						
Ex. rotor winding resistance	0.03148 Ω at 20°C						
Total Harmonic Distortion	THD<3.5% at no load operation or rated Linear balanced load						
Voltage regulation	±1 %						
Telephone Interference	THF<2%			TIF<50			
Frequency	50 Hz			60 Hz			
Speed	1500 rpm			1800 rpm			
Cooling Air	1.65 m ³ /sec			1.98 m ³ /sec			
Voltage series star 3 ph.	380/220	400/231	415/240	415/240	440/254	460/266	480/277
Voltage series delta 3 ph.	220	230	240	240	254	266	277
Rated continuous output	1990 kVA	2100 kVA	2100 kVA	2180 kVA	2310 kVA	2415 kVA	2520 kVA
Xd(u)	3.701	3.525	3.275	4.080	3.846	3.679	3.525
Xd(s)	3.025	2.713	2.364	3.566	3.245	2.984	2.713
Xq(u)	1.899	1.808	1.680	2.093	1.973	1.887	1.808
X'd(u)	0.215	0.204	0.190	0.237	0.223	0.213	0.204
X'd(s)	0.195	0.186	0.173	0.215	0.203	0.194	0.186
X''d(u)	0.135	0.129	0.120	0.148	0.139	0.133	0.128
X''d(s)	0.123	0.117	0.109	0.134	0.127	0.121	0.116
X''q(u)	0.171	0.163	0.152	0.189	0.178	0.170	0.163
X''q(s)	0.156	0.148	0.138	0.172	0.162	0.155	0.148
X1(u)	0.080	0.077	0.071	0.089	0.084	0.080	0.077
X2(u)	0.153	0.146	0.136	0.168	0.159	0.152	0.145
X2(s)	0.140	0.133	0.123	0.153	0.144	0.138	0.132
X0(u)	0.020	0.019	0.018	0.022	0.021	0.020	0.019
Xp(s)	0.161	0.153	0.142	0.177	0.167	0.160	0.153
SCR (short circuit ratio), Ir0/Xd (u)	0.33	0.37	0.42	0.28	0.31	0.34	0.37
s=saturated value, u=unsaturated value, values are p.u. at rated voltage and power.							
Td0'	6.021 s						
Td'	0.349 s						
Td''	0.0291 s						
Ta	0.0361 s						
CE-Marking	Generator fulfills the requirements of Low Voltage Directive (2014/35/EU) Generator supplied to EEA-area will be CE-marked						

	ABB Generators Ltd.	Document identification	Lang.	Rev. ind.	Sheet
		8AMG 5903664	en	A	2

TEMPLATE: TECHNICALSPECIFICATION.DOT; FILENAME: 8AMG5903664-A-NMG 0450CC04 TECHNICAL SPECIFICATION.DOC; PRINTDATE: 9/20/2017 3:05:00 PM; SAVEDATE: 7/29/2017 4:09:00 PM

2 PERFORMANCE CURVES

THREE PHASE EFFICIENCY CURVES, 50 Hz/380–415 V



ABB Generators Ltd.

Document identification

8AMG 5903664

Lang.

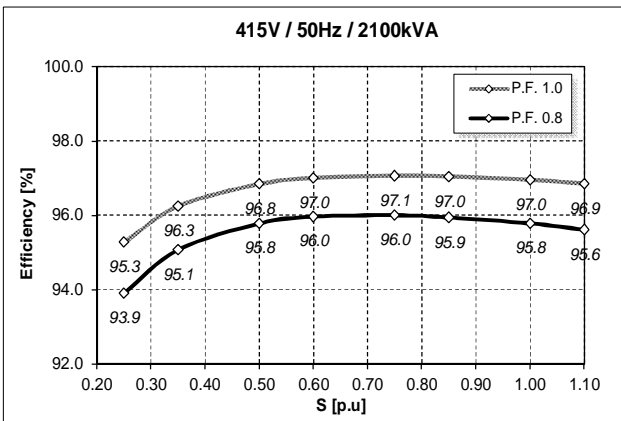
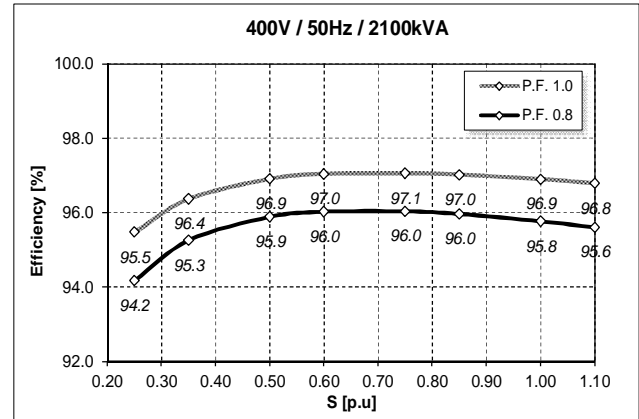
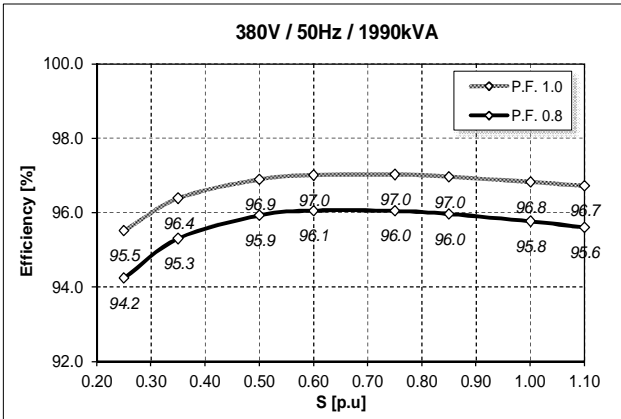
en

Rev. ind.

A

Sheet

3

THREE PHASE EFFICIENCY CURVES, 60 Hz/415–480 V

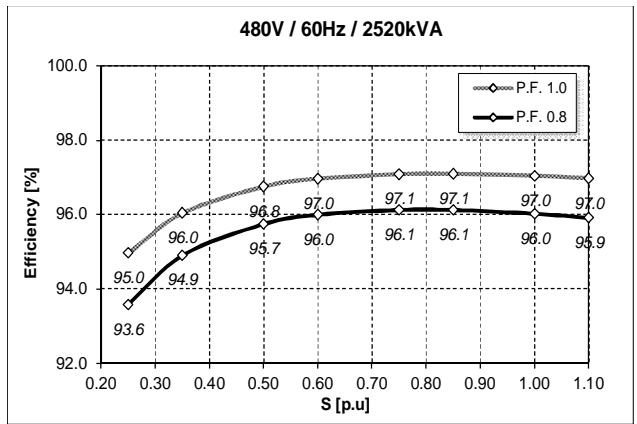
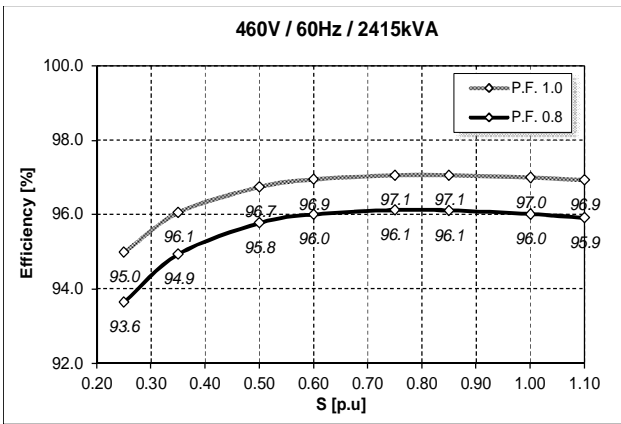
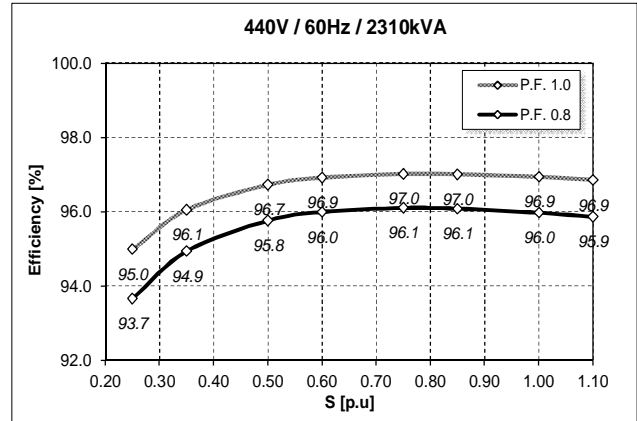
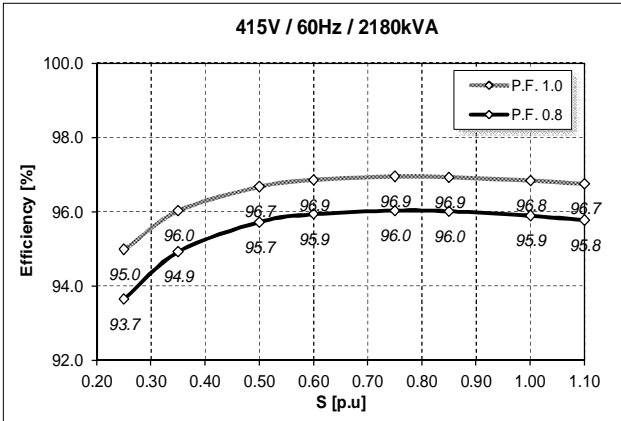

TRANSIENT VOLTAGE REGULATION CURVES

Load application:

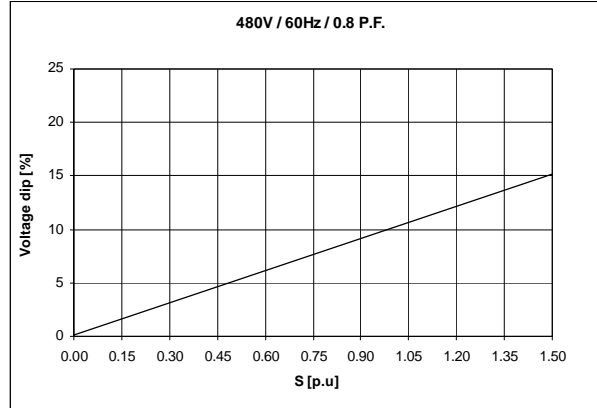
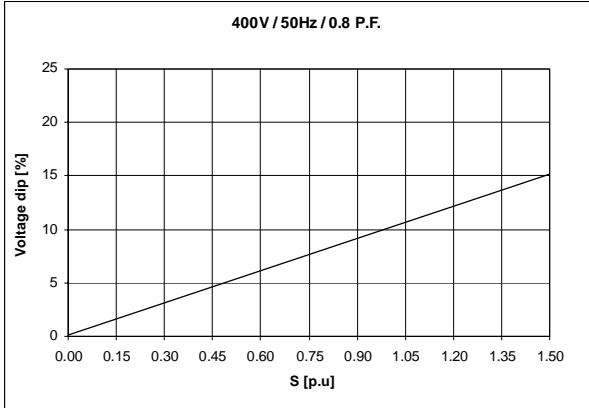

Load rejection:

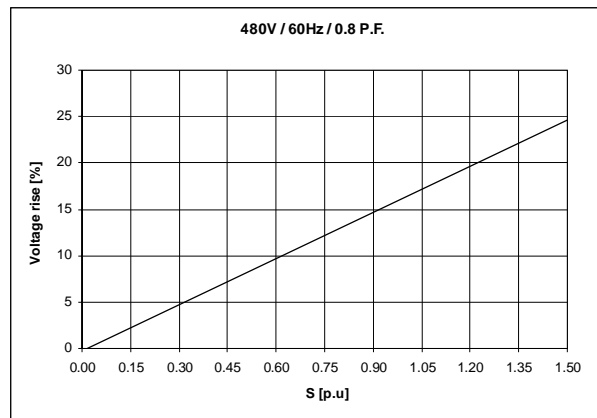
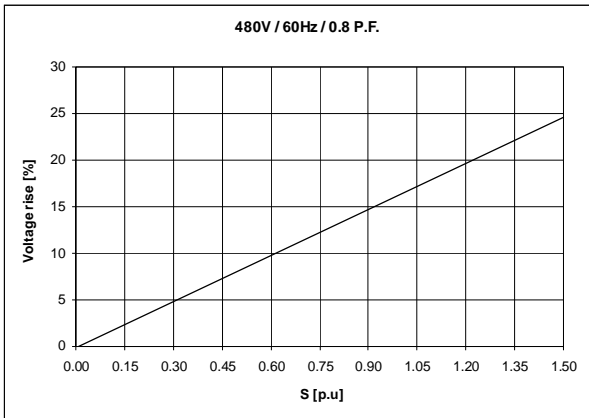

Locked Rotor Motor Starting Curve:

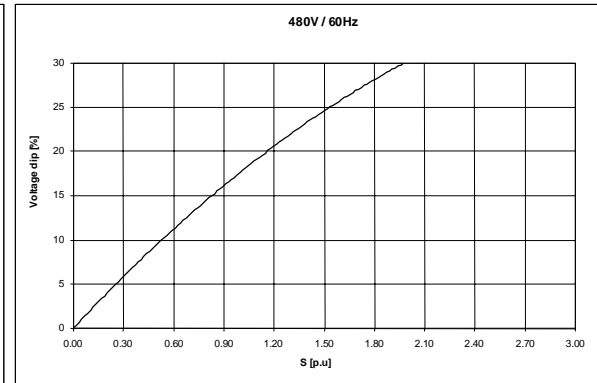
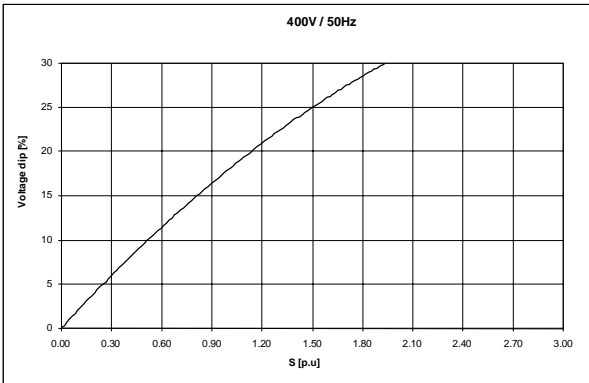

Note1

S [P.U] = S/S(Rated), S stands for the actual operation capacity, S(Rated) stands for the generator rated output capacity.

	ABB Generators Ltd.	Document identification	Lang.	Rev. ind.	Sheet
		8AMG 5903664	en	A	5

THREE PHASE SHORT-CIRCUIT CURVES (At no-load and rated speed, base on star connection)

50Hz

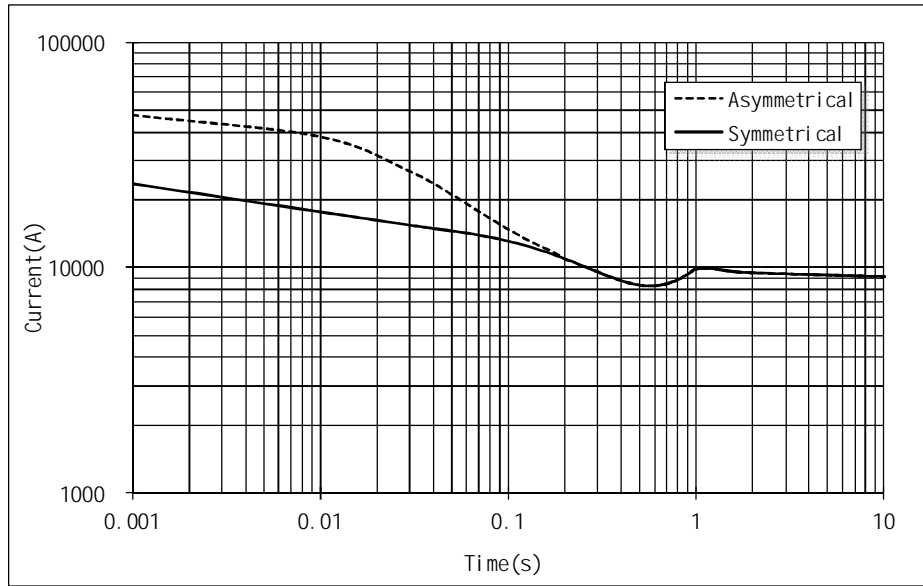

60Hz

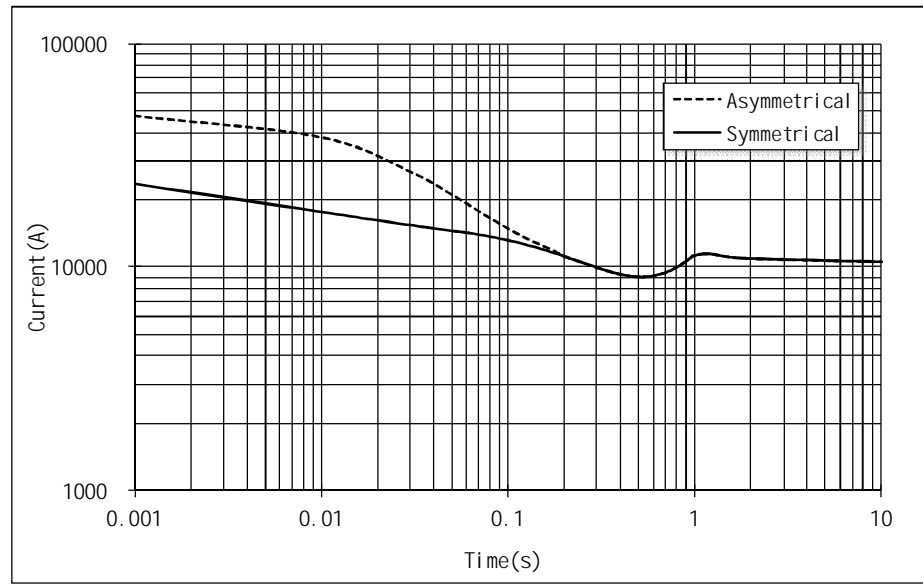

Note2

Curves are for star connection. For other connection, please use following multiplication factors:
 Series delta: Current values x 1.732
 Parallel star: Current values x 2

Curves are for 3-phase short-circuit. For other types of short-circuit, please use following multiplication factors:

	Instantaneous	Continuous	Maximum duration
3-phase	1	1	10 sec.
2-phase L/L	0.87	1.5	5 sec.
1-phase L/N	1.3	2.2	2 sec.

ABB	ABB Generators Ltd.	Document identification	Lang.	Rev. ind.	Sheet
		8AMG 5903664	en	A	6

3 CONFIGURATION AND SCOPE OF SUPPLY

GENERAL

The generator is designed to operate together with a diesel or gas engine. Compliance with the maximum vibration level of the genset to be verified by the genset manufacturer who is responsible for the fully compatibility of all components of the genset according to ISO 8528-5:2005, §15.10. ABB generators vibration are comply with ISO 8528-9 Annex C: value 2 in table C.1. if the vibration of RIC engine is comply with ISO 8528-9.

CONSTRUCTION

The stator frame is a rigid welded steel structure construction. The stator core is built of thin electric sheet steel laminations which are insulated on both sides with heat-resistant inorganic resin.

The rotor consists of a shaft and a star shape rotor core. The shaft is machined of rolled steel. Special heat treatment is used if shaft operates under heavy conditions. The poles are manufactured of 0.5 mm sheet steel. The pole laminations are pressed and welded together with steel bars. These bars are then welded to the end plates. Rotor balancing is done acc. to ISO 1940/1. The standard balancing quality grade is G2.5.

All windings are completely vacuum pressure impregnated with high quality resin. The windings are provided with very strong bracing which withstands all expected mechanical and electrical shocks and vibrations as well as chemicals.

End shields are made of casted steel, The stator frame and stator core are welded together, and bolted with end shields.

MAIN TERMINAL SPACE

Protection class IP44, Integrated into the top module of the generator.

Supply cable entries: Closed terminal box. Cable inlet to the main terminal box to be done by the customer.

Six (6) terminals: U1, V1, W1 and U2, V2, W2 brought to the main terminal box. Neutral point (N) made inside the terminal box by separate copper bar connecting U2, V2, W2 together. Main terminals U, V, W and neutral point N in the main terminal box for external connection.

Terminal marking acc. to IEC.

Designed for continuous current load.

FOUNDATION

The machine can be mounted using shimming, machined blocks, chock fast or on grouted sole plates or bed plate. Before using other mountings, contact us.

CONTROL SYSTEMS

Brushless excitation.

BEARINGS

Non Drive-end: Rolling, sealed, free. Drive-end: Rolling, regrease, locked.(Double bearing)

Maximum bearing temperature 90 °C at ambient 40°C.

TESTING

Testing is according to IEC and ABB internal requirements. The test may be observed by the customer without extra charges.

The test procedures are described in the following documents which are available on request:

- Routine tests: for all machines;
- Type tests: optional, to be agreed separately;
- Special tests: optional, to be agreed separately;

SURFACE TREATMENT

Grade: C2, Standard color

Surface treatment C2 according to the ISO 12944 standard, for standard industrial environment.

ACCESSORIES

Descriptions	PCS	S/O (S: Standard, O:Optional)	Note
Voltage regulator	*Analogue AVR, GEN06	1	S
	Digital AVR	1	O Loose supply
Remote voltage regulator	1	O	
Current transformer for parallel operation	1	O	
PT100 for stator winding	6	O	
PT100 for bearing	1/bearing	O	
Anti-condensation heater	2	O	
PMG exciter	1	S	

*Analogue voltage regulator

Analogue AVR	Excitation Power			Option Functions		
	Shunt	Auxiliary winding	PMG	2CT for paralleling	Remote Voltage Regulator	Analogue Voltage Input
GEN06	x	x	x	x	x	x

ABB	ABB Generators Ltd.	Document identification			Lang.	Rev. ind.	Sheet
		8AMG 5903664			en	A	7

TEMPLATE: TECHNICALSPECIFICATION.DOT; FILENAME: 8AMG5903664-A-NMG 0450CC04 TECHNICAL SPECIFICATION.DOC; PRINTDATE: 9/20/2017 3:05:00 PM; SAVE DATE: 7/29/2017 4:09:00 PM

4 DIMENSIONS

MAIN DIMENSIONS

Single bearing

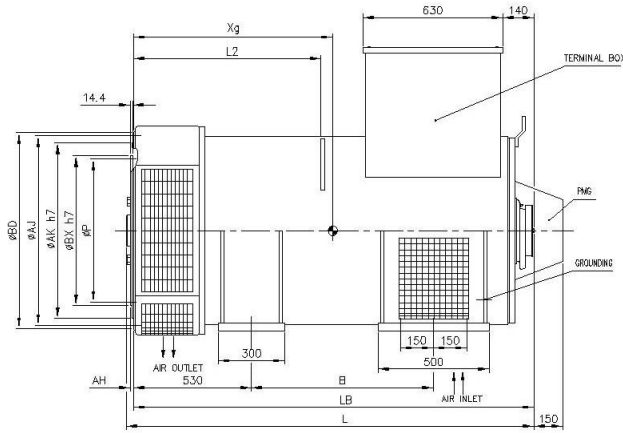

Double bearing

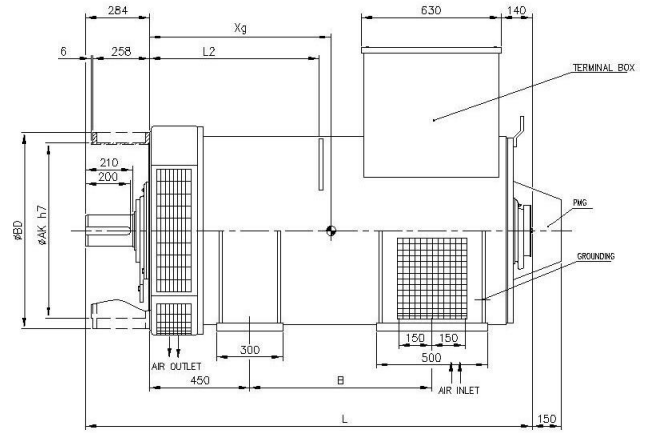

Flange dimensions (mm)

S.A.E	AK	AJ	BD	BF	n	a
0	647.7	679.45	711	14	16	11.25°
00	787.4	851	883	14	16	11.25°

Flex disc dimensions (mm)

S.A.E	BX	P	AH	y	m
18	571.5	543.0	15.7	18	6
21	673.1	641.3	0	18	12

	ABB Generators Ltd.	Document identification	Lang.	Rev. ind.	Sheet
		8AMG 5903664	en	A	8

TEMPLATE: TECHNICALSPECIFICATION.DOT; FILENAME: 8AMG5903664-A-NMG 0450CC04 TECHNICAL SPECIFICATION.DOC; PRINTDATE: 9/20/2017 3:05:00 PM; SAVEDATE: 7/29/2017 4:09:00 PM

