

# Interface Relays and Optocouplers R600 Series

Power and productivity  
for a better world™





## Contents

<b>Introduction: Standard Range R600 .....</b>	<b>2</b>
<b>Relay modules</b>	
Coding principle .....	4
R600 relay blocks .....	5
<b>Optocoupler modules</b>	
Coding principle .....	12
R600 optocoupler blocks .....	13

# STANDARD RANGE R600

## COMFORT

### EASY MARKING

Box function with markers type RC610  
 Wire connection with markers type RC65  
 Electrical schematic of the block on the side of the block

Type RC610

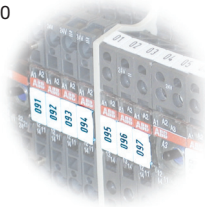

Type RC65

### MANUAL OR AUTOMATIC FUNCTIONNING

Micro-Switch allowing forcing of the coil input to 0 or 1 for interventions in equipments.

Two possibilities:

With a visible switch located on front side. (Fig. 1)

With a secure switch (Fig. 2) after access hatch opening (Fig. 3)

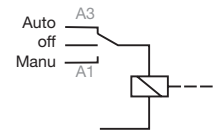

(Fig. 1)



(Fig. 3)

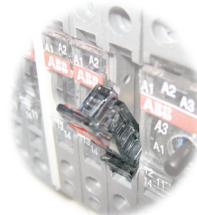

(Fig. 2)



### FUNCTIONNING STATUS

Functioning display through a green Led.

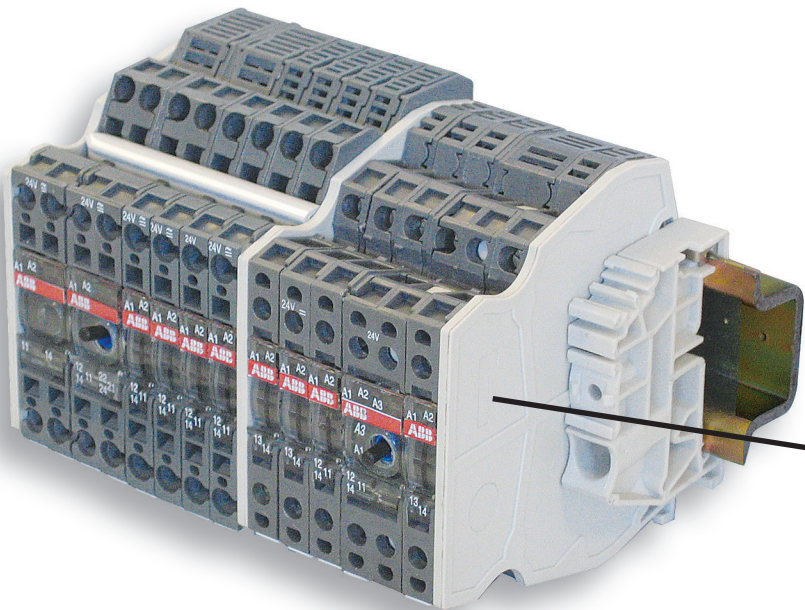

### JUMPER BAR

Same jumper bar for «Screw clamp» or «Spring clamp» technologies. Independent of wire clamp and snap on held in place. Use of end sections is required to preserve IP20 protection.

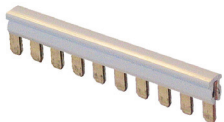

### DISTRIBUTION BLOCK

«Screw clamp» or «Spring clamp» technologies. With protection connected to the rail.

For polarity distribution on demand : coils and/ or contacts.

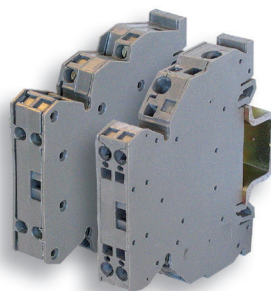

### MESUREMENTS - TESTS

Holes for holding DIA. 2 mm test plugs of the measurement apparatus in position.



### EASY WIRING

DIA. 3,5 mm screwdriver self-gripped into spring

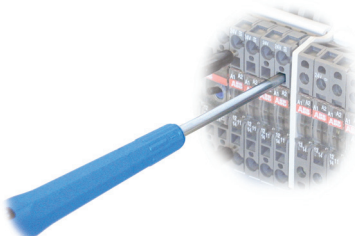

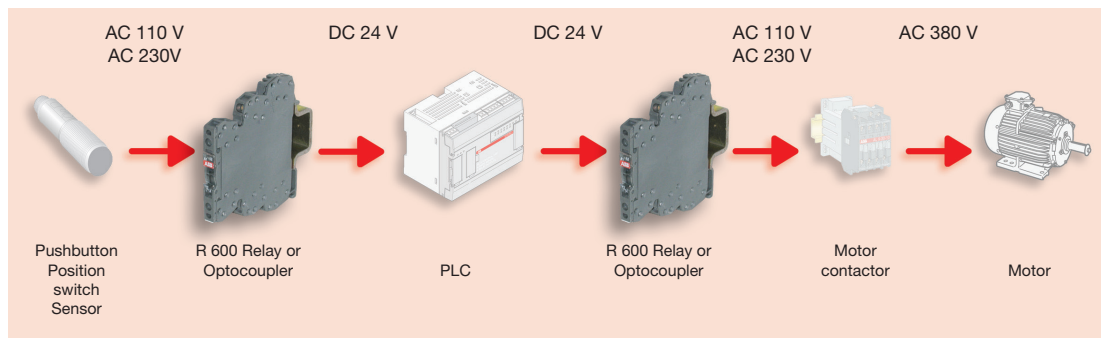

**ABB PROVIDES A FULL SOLUTION FROM SENSOR TO MOTOR**

## SAVING

### CONTACT LIFE INCREASED

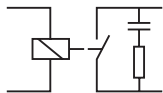

Contact protection through RC circuit

### ONLY ONE PART NUMBER AC/DC

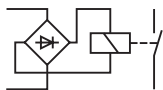

### DIMENSIONS

Compact block in «spring clamp» or «screw clamp» versions with 6 mm and 12 mm spacings.

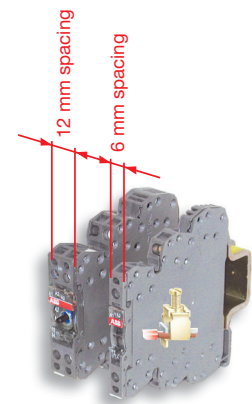
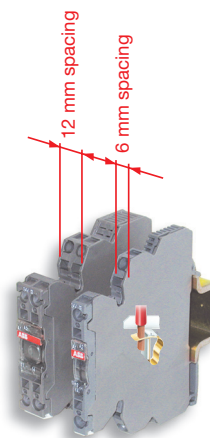

## SAFETY

### SEPARATION AND IDENTIFICATION OF SEVERAL VOLTAGES

Separator end sections.

### IP20 PROTECTION

### NO DISTURBANCE PRODUCTION

Choice of high quality electronic components to reduce leakage currents (< 50 µA).

### IMMUNITY

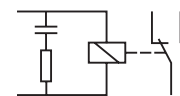

Leakage current protection

### ACCORDANCE TO STANDARDS :



## PERFORMANCES

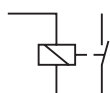

1 NO

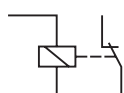

1 NC

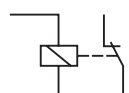

1 SPDT

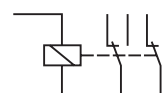

1 DPDT

### ADAPTABILITY TO ANY APPLICATION TYPE

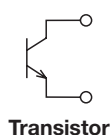

Transistor

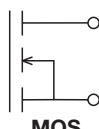

MOS



Triac



### THE PLUS IN OUR PERFORMANCES

- Triac output 400 VAC (50 Hz / 60 Hz)
- Relay output 12 A in 12 mm spacing
- Screw clamp or spring clamp connections

# Relays and optocouplers

## Coding principle

### Construction of description type

SERIES	CODE	NB OF RELAYS	CONTACT TYPE	NB OF CONTACTS PER RELAY	PARTICULARITIES			
R 600 	<table border="1"><tr><td>R</td><td>B</td></tr></table>	R	B	<input type="checkbox"/>	<input type="checkbox"/>	<input type="checkbox"/>	<input type="checkbox"/>	
R	B							
R 600 	<table border="1"><tr><td>R</td><td>B</td><td>R</td></tr></table>	R	B	R	<input type="checkbox"/>	<input type="checkbox"/>	<input type="checkbox"/>	<input type="checkbox"/>
R	B	R						
			↓		↓			
			0 1 2 3		None A B C N P R V I			

#### Description of contact types

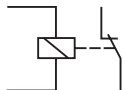
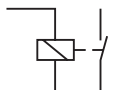
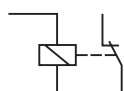
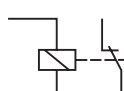
0		1 Normally Closed	1 NC
1		1 Normally Open	1 NO
2		1 Change Over or Single Pole Double Through	
3		1 Normally Closed + 1 Normally Open	1 NC + 1 NO

#### Particularities description

<b>None</b>	Input voltage	DC
<b>A</b>	Input voltage	AC/DC
<b>B</b>	Input voltage	AC
<b>C</b>	2 wire sensor compatibility	

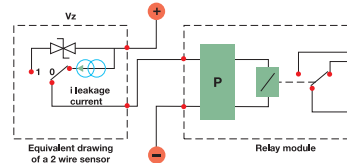

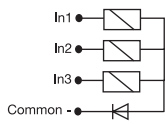
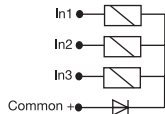
<b>N</b>		Commons of coils connected to negative
<b>P</b>		Commons of coils connected to positive

**R** RC circuit protection :  
- Input protection against leakage current

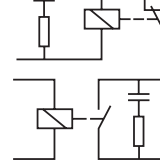

- Increases relay contacts life



**V** Relay protection against overvoltage peaks

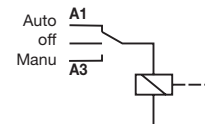

**I** Switch to force the coil for maintenance and/or installation purposes



#### Color coding for relays

Color	Current level in contacts	Switching current	Switching voltage	Switching load power
 green	Very low level	10 <sup>-7</sup> to 5 A	10 <sup>-3</sup> to 250 V	10 <sup>-10</sup> to 2000 VA 10 <sup>-10</sup> to 200 W
 grey	Low level	1 mA to 8 A	5 to 250 V	0,05 to 1500 VA 0,05 to 192 W
 blue	High level	10 mA to 16 A	12 to 380 V	0,6 to 4000 VA 0,6 to 240 W

# Relays and optocouplers

## Relay Interfaces

### R600 relay modules

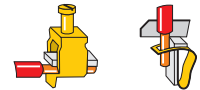

DIN 3

Relay : 1NO or 1NC high level contact 10 mA to 6 A - 6 mm .236" or 12 mm .472" spacing

#### Characteristics

Relay characteristics COIL	RB 111 A				RB 111 AI	RB 111 AR	RB 101 AR
	24 VAC/DC	115 VAC/DC	230 VAC/DC	±10% on AC +10% -15% on DC	24 VAC/DC	24 VAC/DC	24 VAC/DC
Rated voltage +20%, -15% on DC ; +10%, -10% on AC	24 VAC/DC	115 VAC/DC	230 VAC/DC	±10% on AC +10% -15% on DC	24 VAC/DC	24 VAC/DC	24 VAC/DC
Frequency	50 / 60 Hz	50 / 60 Hz	50 / 60 Hz	50 / 60 Hz	50 / 60 Hz	50 / 60 Hz	50 / 60 Hz
Power	0,24 W	0,46 W	0,8 W	0,24 W	0,24 W	0,24 W	0,24 W
Rated current	10 mA	4 mA	3,5 mA	10 mA	10 mA	10 mA	10 mA
Drop-out voltage at 20°C	4,5 V	17 V	27 V	4,5 V	4,5 V	4,5 V	4,5 V
Status device	green LED				green LED	green LED	green LED
<b>CONTACT</b>							
Type	1 NO				1 NO + RC	1 NO + RC	1 NC + RC
Voltage switching range min./max.	12 V / 250 V AC						
Current switching range min./max.	10 mA / 6 A						
Load switching range	0,6 VA / 1500 VA (ohmic load)						
AC1 min. / max.	0,6 W / 140 W						
DC1 min. / max.	10 <sup>5</sup> on AC15						
Number of on-load operations	10 <sup>7</sup>						
Number of off-load operations							
Operating speed	F 5 ms		6 ms	7 ms	5 ms	5 ms	5 ms
	O 8 ms		15 ms	15 ms	8 ms	8 ms	8 ms
Bounce	1,2 ms				1,2 ms	1,2 ms	1,2 ms
Insulation coil / contact	4000 V RMS				3800 V RMS	4000 V RMS	4000 V RMS
Resistance to shock coil / contact	4000 V RMS						
Insulation contact / contact	1000 V RMS						
Ambient temperature	-40°C to +80°C						
operating	-20°C to +70°C (1)						
<b>Other characteristics</b>							
Body material	Screw clamp UL 94 V0				Spring clamp UL 94 V0		
Wire	Solid wire 0,2 - 4 mm <sup>2</sup> / 24 - 12 AWG				0,2 - 2,5 mm <sup>2</sup> / 24 - 12 AWG		
size	Stranded wire 0,22 - 2,5 mm <sup>2</sup> / 24 - 12 AWG				0,22 - 2,5 mm <sup>2</sup> / 24 - 12 AWG		
Rated wire size	2,5 mm <sup>2</sup> / 12 AWG				2,5 mm <sup>2</sup> / 12 AWG		
Wire stripping length	9 mm .354"				9 mm .354"		
Recommended screwdriver	3,5 mm .137"				3,5 mm .137"		
Protection	IP20 NEMA1				IP20 NEMA1		
Recommended torque	0,4 - 0,6 Nm 3.5 - 5.3 lb.in				0,4 - 0,6 Nm 3.5 - 5.3 lb.in		
Approvals	LRS, CE						
Reference standards	CEI 947-7-1 / CEI 947-1 / CEI 1131-2 (in relevant parts) / CEI 60664-1 / CEM : IRC 1000-4-2, 3, 4, 5, 6.						

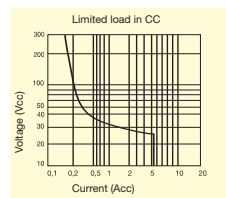

(1) Over 55°C, blocks have to be mounted on horizontal rail with 10 mm spacing between each block. For vertical rail mounting use temperature is 15°C less decreased.

	DC12	AC12	DC13	AC15
24 V	6 A	6 A	1 A	3 A
110/120 V	0,3 A	6 A	0,2 A	3 A
220/230 V	0,2 A	6 A	0,1 A	3 A

#### Order codes

Description	Type	Order P/N	Packaging	Weight
Relay module 1 NO high level 6 mm spacing	RB 111 A-24VAC/DC	1SNA 645 014 R2700	10	0,02
Relay module 1 NO high level 6 mm spacing	RB 111 A-115VAC/DC	1SNA 645 016 R2100	10	0,02
Relay module 1 NO high level 6 mm spacing	RB 111 A-230VAC/DC	1SNA 645 017 R2200	10	0,02
Relay mod. 1 NO high level w/safety switch 6 mm spacing	RB 111 AI-24VAC/DC	1SNA 645 063 R0000	10	0,02
Relay mod. 1 NO high level w/contact protection 12 mm sp.	RB 111 AR-24VAC/DC	1SNA 645 018 R0300	5	0,03
Relay mod. 1 NC high level w/contact protection 12 mm sp.	RB 101 AR-24VAC/DC	1SNA 645 019 R0400	5	0,03
Relay module 1 NO high level 6 mm spacing	RBR 111 A-24VAC/DC	1SNA 645 514 R2100	10	0,02
Relay mod. 1 NO high level w/safety switch 6 mm spacing	RBR 111 AI-24VAC/DC	1SNA 645 563 R0200	10	0,02
Relay mod. 1 NO high level w/contact protection 12 mm sp.	RBR 111 AR-24VAC/DC	1SNA 645 518 R0500	5	0,03
Relay mod. 1 NC high level w/contact protection 12 mm sp.	RBR 101 AR-24VAC/DC	1SNA 645 519 R0600	5	0,03

#### Accessories

Description	Type	Order P/N	Packaging	Weight
End section	BADH V0	1SNA 116 900 R2700	50	
	BADL V0	1SNA 399 903 R0200	50	
	BAM2 V0	1SNA 399 967 R0100	50	
Separator end section	SC 612	1SNA 290 474 R0200	10	
Divisible shunt 10 poles	BJ 612-10	1SNA 290 488 R0100	10	
Test plug DIA. 2 mm	FC2	1SNA 007 865 R2600	10	
Marking method	RC65 RC610	see marking catalogue		

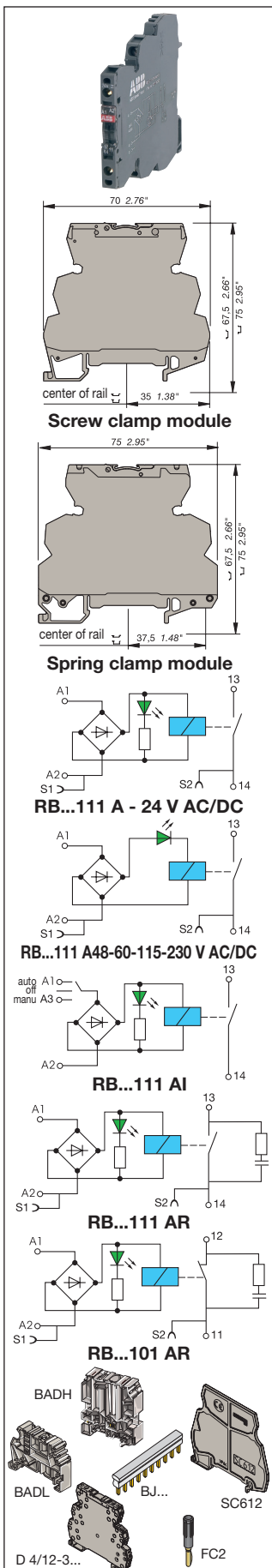

# Relays and optocouplers

## Relay Interfaces

### R600 relay modules

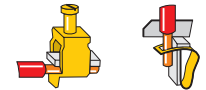

DIN 3

Relay : 1 SPDT high level contact 10 mA to 6 A - 6 mm .236" spacing

#### Characteristics

Relay characteristics COIL	RB 121			RB 121A				
	5 V DC	12 V DC	24 V DC	24 VAC/DC	48 V AC/DC	60 V AC/DC	115 V AC/DC	230 V AC/DC
Rated voltage +20%, -15% on DC ; +10%, -10% on AC								±10% on AC +10% -15% on DC
Frequency				50 / 60 Hz	50 / 60 Hz	50 / 60 Hz	50 / 60 Hz	50 / 60 Hz
Power	0,2 W	0,2 W	0,28 W	0,24 W	0,33 W	0,54 W	0,46 W	0,8 W
Rated current	40 mA	16 mA	12 mA	10 mA	7 mA	9 mA	4 mA	3,5 mA
Drop-out voltage at 20°C	1,2 V	2,2 V	1,2 V	4,5 V	8 V	8 V	17 V	27 V
Status device	green LED							

#### CONTACT

Type	1 SPDT								
Voltage switching range min./max.	12 V / 250 V AC								
Current switching range min./max.	10 mA / 6 A								
Load switching range	0,6 VA / 1500 VA (ohmic load) 0,6 W / 140 W								
Number of on-load operations	10 <sup>5</sup> on AC15								
Number of off-load operations	10 <sup>7</sup>								
Operating speed	F	5 ms	5 ms	5 ms	5 ms	5 ms	5 ms	6 ms	7 ms
	O	8 ms	8 ms	8 ms	8 ms	8 ms	8 ms	15 ms	16 ms
Bounce	1,2 ms								
Insulation coil / contact	4000 V RMS								
Resistance to shock coil / contact	4000 V RMS								
Insulation contact / contact	1000 V RMS								
Ambient temperature storage	-40°C to +80°C								
operating	-20°C to +70°C (1)								

#### Other characteristics

	Screw clamp	Spring clamp
Body material	grey	grey
Wire	UL 94 V0	UL 94 V0
Wire size	0,2 - 4 mm <sup>2</sup> / 24 - 12 AWG	0,2 - 2,5 mm <sup>2</sup> / 24 - 12 AWG
Stranded wire	0,22 - 2,5 mm <sup>2</sup> / 24 - 12 AWG	0,22 - 2,5 mm <sup>2</sup> / 24 - 12 AWG
Rated wire size	2,5 mm <sup>2</sup> / 12 AWG	2,5 mm <sup>2</sup> / 12 AWG
Wire stripping length	9 mm .354"	9 mm .354"
Recommended screwdriver	3,5 mm .137"	3,5 mm .137"
Protection	IP20 NEMA1	IP20 NEMA1
Recommended torque	0,4 - 0,6 Nm 3.5 - 5.3 lb.in	0,4 - 0,6 Nm 3.5 - 5.3 lb.in

#### Approvals



#### Reference standards

CEI 947-7-1 / CEI 947-1 / CEI 1131-2 (in relevant parts) / CEI 60664-1 / CEM : IRC 1000-4-2, 3, 4, 5, 6.

(1) Over 55°C, blocks have to be mounted on horizontal rail with 10 mm spacing between each block. For vertical rail mounting use temperature is 15°C less decreased.

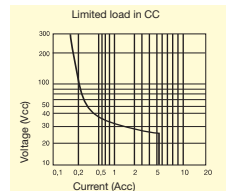

	DC12	AC12	DC13	AC15
24 V	6 A	6 A	1 A	3 A
110/120 V	0,3 A	6 A	0,2 A	3 A
220/230 V	0,2 A	6 A	0,1 A	3 A

#### Order codes

Description	Type	Order P/N	Packaging	Weight kg
Relay module 1 SPDT high level	RB 121-5VDC	1SNA 645 034 R2300	10	0,02
Relay module 1 SPDT high level	RB 121-12VDC	1SNA 645 035 R2400	10	0,02
Relay module 1 SPDT high level	RB 121-24VDC	1SNA 645 064 R0100	10	0,02
Relay module 1 SPDT high level	RB 121 A-24VAC/DC	1SNA 645 001 R0300	10	0,02
Relay module 1 SPDT high level	RB 121 A-48-60VAC/DC	1SNA 645 002 R0400	10	0,02
Relay module 1 SPDT high level	RB 121 A-115VAC/DC	1SNA 645 003 R0500	10	0,02
Relay module 1 SPDT high level	RB 121 A-230VAC/DC	1SNA 645 004 R0400	10	0,02
Relay module 1 SPDT high level	RBR 121-5VDC	1SNA 645 534 R2500	10	0,02
Relay module 1 SPDT high level	RBR 121-12VDC	1SNA 645 535 R2600	10	0,02
Relay module 1 SPDT high level	RBR 121-24VDC	1SNA 645 564 R0300	10	0,02
Relay module 1 SPDT high level	RBR 121 A-24VAC/DC	1SNA 645 501 R0500	10	0,02
Relay module 1 SPDT high level	RBR 121 A-48-60VAC/DC	1SNA 645 502 R0600	10	0,02
Relay module 1 SPDT high level	RBR 121 A-115VAC/DC	1SNA 645 503 R0700	10	0,02
Relay module 1 SPDT high level	RBR 121 A-230VAC/DC	1SNA 645 504 R0000	10	0,02

#### Accessories

Description	Type	Order P/N	Packaging	Weight kg
End section	BADH V0	1SNA 116 900 R2700	50	
	BADL V0	1SNA 399 903 R0200	50	
	BAM2 V0	1SNA 399 967 R0100	50	
Separator end section	SC 612	1SNA 290 474 R0200	10	
Divisible shunt 10 poles	BJ 612-10	1SNA 290 488 R0100	10	
Test plug DIA. 2 mm	FC2	1SNA 007 865 R2600	10	
Marking method	RC65 RC610	see marking catalogue		

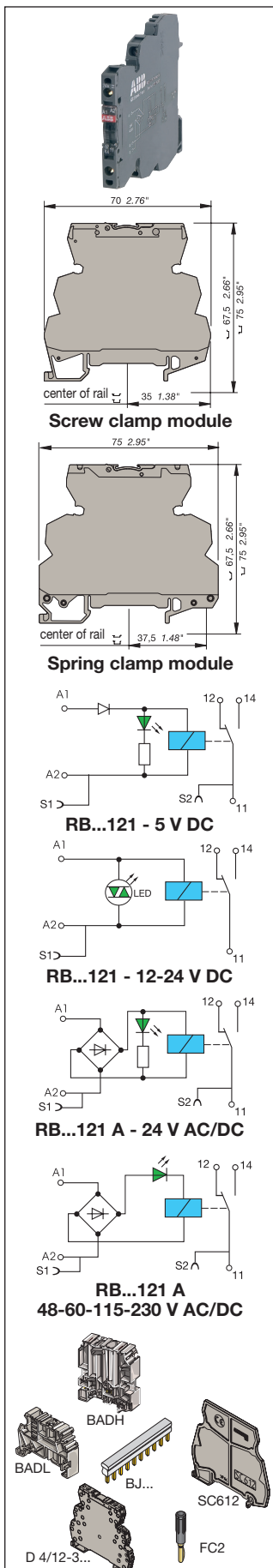



# Relays and optocouplers

## Relay Interfaces

### R600 relay modules

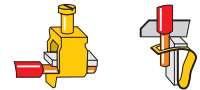

DIN 3

Relay : 1 SPDT low level contact 1 mA upto 6 A - 6 mm .236" spacing

#### Characteristics

Relay characteristics COIL	RB 121			RB 121 A					
	5 V DC	12 V DC	24 V DC	24 VAC/DC	48 V AC/DC	60 V AC/DC	115 V AC/DC	±10% on AC +10% -15% on DC 230 V AC/DC	
Rated voltage +20%, -15% on DC ; +10%, -10% on AC				50 / 60 Hz	50 / 60 Hz	50 / 60 Hz	50 / 60 Hz	50 / 60 Hz	
Frequency	0,2 W	0,2 W	0,28 W	0,24 W	0,33 W	0,54 W	0,46 W	0,8 W	
Power	40 mA	16 mA	12 mA	10 mA	7 mA	9 mA	4 mA	3,5 mA	
Rated current	1,2 V	2,2 V	1,2 V	4,5 V	8 V	8 V	17 V	27 V	
Drop-out voltage at 20°C	green LED								
Status device									
<b>CONTACT</b>									
Type	1 SPDT								
Voltage switching range min./max.	5 V / 250 V AC								
Current switching range min./max.	1 mA / 6 A								
Load switching range	0,05 VA / 1500 VA (ohmic load)								
AC1 min. / max. DC1 min. / max.	0,05 W / 140 W								
Number of on-load operations	10 <sup>5</sup> on AC15								
Number of off-load operations	10 <sup>7</sup>								
Operating speed	F 5 ms	5 ms	5 ms	5 ms	5 ms	5 ms	6 ms	7 ms	
	O 8 ms	8 ms	8 ms	8 ms	8 ms	8 ms	15 ms	16 ms	
Bounce	1,2 ms								
Insulation coil / contact	4000 V RMS								
Resistance to shock coil / contact	4000 V RMS								
Insulation contact / contact	1000 V RMS								
Ambient temperature	-40°C to +80°C								
storage	-20°C to +70°C (1)								
operating									
<b>Other characteristics</b>									
Body material	grey				Screw clamp UL 94 V0				Spring clamp UL 94 V0
Wire	Solid wire				0,2 - 4 mm <sup>2</sup> / 24 - 12 AWG		0,2 - 2,5 mm <sup>2</sup> / 24 - 12 AWG		
size	Stranded wire				0,22 - 2,5 mm <sup>2</sup> / 24 - 12 AWG		0,22 - 2,5 mm <sup>2</sup> / 24 - 12 AWG		
Rated wire size					2,5 mm <sup>2</sup> / 12 AWG		2,5 mm <sup>2</sup> / 12 AWG		
Wire stripping length					9 mm .354"		9 mm .354"		
Recommended screwdriver					3,5 mm .137"		3,5 mm .137"		
Protection					IP20 NEMA1		IP20 NEMA1		
Recommended torque					0,4 - 0,6 Nm 3,5 - 5,3 lb.in		0,4 - 0,6 Nm 3,5 - 5,3 lb.in		
Approvals									
Reference standards	CEI 947-7-1 / CEI 947-1 / CEI 1131-2 (in relevant parts) / CEI 60664-1 / CEM : IRC 1000-4-2, 3, 4, 5, 6.								

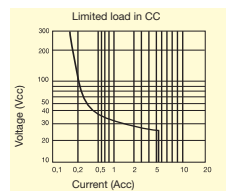

(1) Over 55°C, blocks have to be mounted on horizontal rail with 10 mm spacing between each block. For vertical rail mounting use temperature is 15°C less decreased.

#### Order codes

Description	Type	Order P/N	Packaging	Weight
Relay module 1 SPDT low level	RB 121-5VDC	1SNA 645 036 R2500	10	0,02
Relay module 1 SPDT low level	RB 121-12VDC	1SNA 645 037 R2600	10	0,02
Relay module 1 SPDT low level	RB 121-24VDC	1SNA 645 065 R0200	10	0,02
Relay module 1 SPDT low level	RB 121 A-24VAC/DC	1SNA 645 005 R0700	10	0,02
Relay module 1 SPDT low level	RB 121 A-48-60VAC/DC	1SNA 645 006 R0000	10	0,02
Relay module 1 SPDT low level	RB 121 A-115VAC/DC	1SNA 645 007 R0100	10	0,02
Relay module 1 SPDT low level	RB 121 A-230VAC/DC	1SNA 645 008 R1200	10	0,02
Relay module 1 SPDT low level	RBR 121-5VDC	1SNA 645 536 R2700	10	0,02
Relay module 1 SPDT low level	RBR 121-12VDC	1SNA 645 537 R2000	10	0,02
Relay module 1 SPDT low level	RBR 121-24VDC	1SNA 645 565 R0400	10	0,02
Relay module 1 SPDT low level	RBR 121 A-24VAC/DC	1SNA 645 505 R0100	10	0,02
Relay module 1 SPDT low level	RBR 121 A-48-60VAC/DC	1SNA 645 506 R0200	10	0,02
Relay module 1 SPDT low level	RBR 121 A-115VAC/DC	1SNA 645 507 R0300	10	0,02
Relay module 1 SPDT low level	RBR 121 A-230VAC/DC	1SNA 645 508 R1400	10	0,02

#### Accessories

Description	Type	Order P/N	Packaging	Weight
End section	BADH V0	1SNA 116 900 R2700	50	
	BADL V0	1SNA 399 903 R0200	50	
	BAM2 V0	1SNA 399 967 R0100	50	
Separator end section	SC 612	1SNA 290 474 R0200	10	
Divisible shunt 10 poles	BJ 612-10	1SNA 290 488 R0100	10	
Test plug DIA. 2 mm	FC2	1SNA 007 865 R2600	10	
Marking method	RC65 RC610	see marking catalogue		

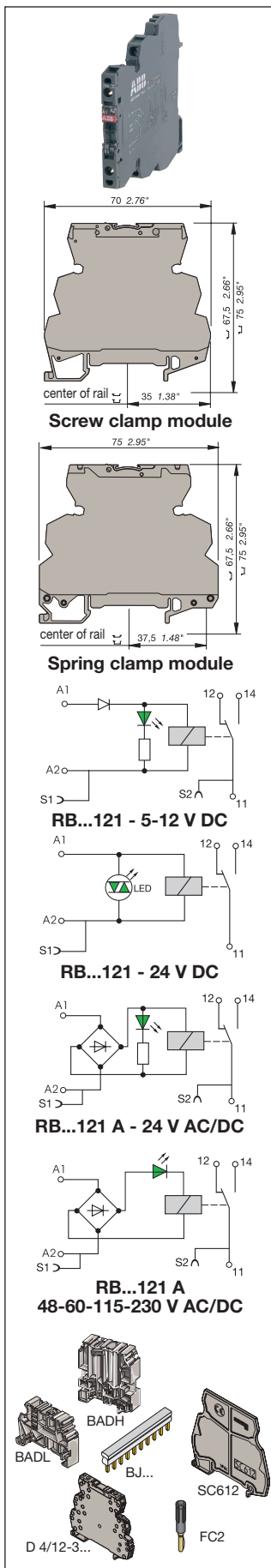

# Relays and optocouplers

## Relay Interfaces

### R600 relay modules

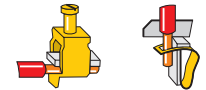

DIN 3

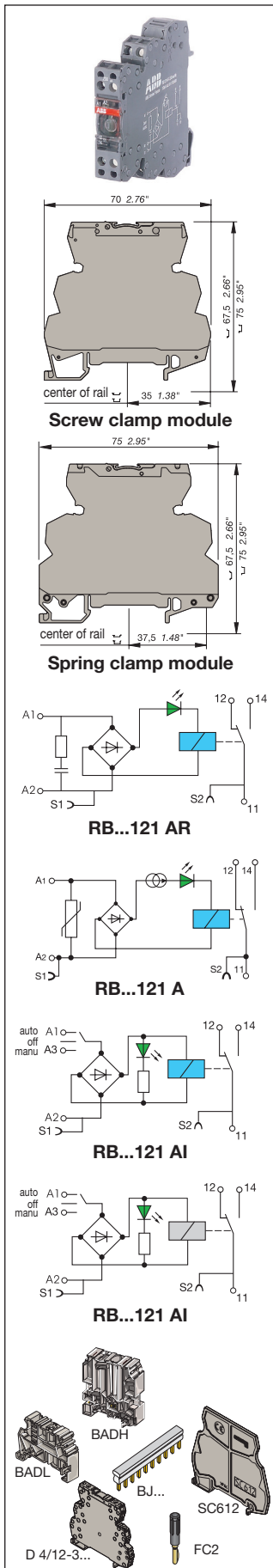

- Relay : 1 SPDT high level with switch or large coil voltage range or with leakage current protection - 12 mm .472" spacing
- Relay : 1 SPDT low level with switch - 12 mm .472" spacing

#### Characteristics

Relay characteristics	RB...121 AR		RB...121 AI		RB...121 AI		RB...121 A
<b>COIL</b>							
Rated voltage +20%, -15% on DC ; +10%, -10% on AC	115 V AC/DC	230 V AC/DC	24 VAC/DC	24 VAC/DC	24 VAC/DC	24 VAC/DC	60 to 253 VAC/DC
Frequency	50 / 60 Hz	50 / 60 Hz	50 / 60 Hz	50 / 60 Hz	50 / 60 Hz	50 / 60 Hz	50 / 60 Hz
Power	2 W	2,8 W	0,24 W	0,24 W	0,24 W	0,24 W	1 W
Rated current	18 mA	12 mA	10 mA	10 mA	10 mA	10 mA	4 mA max.
Drop-out voltage at 20°C	17 V	27 V	4,5 V	4,5 V	4,5 V	4,5 V	15 V
Permissible leakage current	1,6 mA	1 mA					
Status device	green LED			green LED		green LED	
<b>CONTACT</b>							
Type	1 SPDT		1 SPDT		1 SPDT		1 SPDT
Voltage switching range min./max.	12 V / 250 V		5 V / 250 V		12 V / 250 V		12 V / 250 V
Current switching range min./max.	10 mA / 6 A		1 mA / 6 A		10 mA / 6 A		10 mA / 6 A
Load switching range	0,6 VA / 1500 VA (ohmic load) 0,6 W / 140 W		0,05 VA/1500 VA (ohmic load) 0,05 W / 140 W		0,6 VA/1500 VA (ohmic load) 0,6 W / 140 W		0,6 VA/1500 VA (ohmic load) 0,6 W / 140 W
Number of on-load operations	10 <sup>5</sup> on AC15		10 <sup>5</sup> on AC15		10 <sup>5</sup> on AC15		10 <sup>5</sup> on AC15
Number of off-load operations	10 <sup>7</sup>		10 <sup>7</sup>		10 <sup>7</sup>		10 <sup>7</sup>
Operating speed	F 6 ms O 15 ms	7 ms 16 ms	5 ms 8 ms	5 ms 8 ms	5 ms 8 ms	5 ms 8 ms	7 ms 20 ms
Bounce							
Insulation coil / contact	4000 V RMS						
Resistance to shock coil / contact	4000 V RMS						
Insulation contact / contact	1000 V RMS						
Ambient temperature storage	-40°C to +80°C						
operating	-20°C to +70°C (1)						
<b>Other characteristics</b>	Screw clamp		Screw clamp		Spring clamp		
Body material	grey		UL 94 V0		UL 94 V0		
Wire	Solid wire		0,2 - 4 mm <sup>2</sup> / 24 - 12 AWG		0,2 - 2,5 mm <sup>2</sup> / 24 - 12 AWG		
size	Stranded wire		0,22 - 2,5 mm <sup>2</sup> / 24 - 12 AWG		0,22 - 2,5 mm <sup>2</sup> / 24 - 12 AWG		
Rated wire size			2,5 mm <sup>2</sup> / 12 AWG		2,5 mm <sup>2</sup> / 12 AWG		
Wire stripping length			9 mm .354"		9 mm .354"		
Recommended screwdriver			3,5 mm .137"		3,5 mm .137"		
Protection			IP20 NEMA1		IP20 NEMA1		
Recommended torque			0,4 - 0,6 Nm 3.5 - 5.3 lb.in		0,4 - 0,6 Nm 3.5 - 5.3 lb.in		
Approvals	LRS, CE						
Reference standards	CEI 947-7-1 / CEI 947-1 / CEI 1131-2 (in relevant parts) / CEI 60664-1 / CEM : IRC 1000-4-2, 3, 4, 5, 6.						

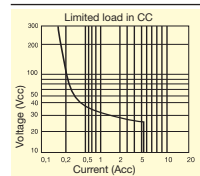

(1) Over 55°C, blocks have to be mounted on horizontal rail with 10 mm spacing between each block. For vertical rail mounting use temperature is 15°C less decreased.

	DC12	AC12	DC13	AC15
24 V	6 A	6 A	1 A	3 A
110/120 V	0,3 A	6 A	0,2 A	3 A
220/230 V	0,2 A	6 A	0,1 A	3 A

#### Order codes

Description	Type	Order P/N	Packaging	Weight kg
Relay mod. 1SPDT high level w/leakage current protec.	RB 121 AR-115VAC/DC	1SNA 645 046 R0700	5	0,03
Relay mod. 1SPDT high level w/leakage current protec.	RB 121 AR-230VAC/DC	1SNA 645 011 R2400	5	0,03
Relay mod. 1SPDT high level w/large coil voltage range	RB 121 A 60-230VAC/DC	1SNA 645 020 R0100	5	0,03
Relay mod. 1SPDT high level with switch	RB 121 AI-24VAC/DC	1SNA 645 032 R2100	5	0,03
Relay mod. 1SPDT high level with safety switch	RB 121 AI-24VAC/DC	1SNA 645 009 R1300	5	0,03
Relay module 1SPDT low level with switch	RB 121 AI-24VAC/DC	1SNA 645 033 R2200	5	0,03
Relay module 1SPDT low level with safety switch	RB 121 AI-24VAC/DC	1SNA 645 010 R0700	5	0,03
Relay mod. 1SPDT high level w/leakage current protec.	RBR 121 AR-115VAC/DC	1SNA 645 546 R0100	5	0,03
Relay mod. 1SPDT high level w/leakage current protec.	RBR 121 AR-230VAC/DC	1SNA 645 511 R2600	5	0,03
Relay mod. 1SPDT high level w/large coil voltage range	RBR 121 A 60-230VAC/DC	1SNA 645 520 R0300	5	0,03
Relay mod. 1SPDT high level with switch	RBR 121 AI-24VAC/DC	1SNA 645 532 R2300	5	0,03
Relay mod. 1SPDT high level with safety switch	RBR 121 AI-24VAC/DC	1SNA 645 509 R1500	5	0,03
Relay module 1SPDT low level with switch	RBR 121 AI-24VAC/DC	1SNA 645 533 R2400	5	0,03
Relay module 1SPDT low level with safety switch	RBR 121 AI-24VAC/DC	1SNA 645 510 R0100	5	0,03

#### Accessories

Description	Type	Order P/N	Packaging	Weight kg
End section	BADH V0	1SNA 116 900 R2700	50	
	BADL V0	1SNA 399 903 R0200	50	
	BAM2 V0	1SNA 399 967 R0100	50	
Separator end section	SC 612	1SNA 290 474 R0200	10	
Divisible shunt 10 poles	BJ 612-10	1SNA 290 488 R0100	10	
Test plug DIA. 2 mm	FC2	1SNA 007 865 R2600	10	
Marking method	RC65 RC610	see marking catalogue		

# Relays and optocouplers

## Relay Interfaces

### R600 relay modules

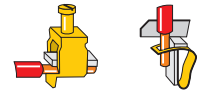

DIN 3

Relay : 1 DPDT low level contact 1 mA to 8 A - 12 mm .472" spacing

#### Characteristics

Relay characteristics		RB...122A				
<b>COIL</b>						±10% on AC +10% -15% on DC 230 V AC/DC
Rated voltage	+20%, -15% on DC ; +10%, -10% on AC	24 VAC/DC	48 V AC/DC	60 V AC/DC	115 V AC/DC	50 / 60 Hz
Frequency		50 / 60 Hz	50 / 60 Hz	50 / 60 Hz	50 / 60 Hz	50 / 60 Hz
Power		0,48 W	0,62 W	0,96 W	0,58 W	1,15 W
Rated current		20 mA	13 mA	16 mA	5 mA	5 mA
Drop-out voltage at 20°C		5,4 V	8,8 V	8,8 V	20 V	10 V
Status device		green LED				
<b>CONTACT</b>		1 DPDT				
Type		5 V / 250 V DC - 250 V AC				
Voltage switching range min./max.		1 mA / 8 A				
Current switching range min./max.		1 mA / 5 A				
Load switching range		5 mVA / 1500 VA				
AC1 min. / max.		5 mW / 192 W				
DC1 min. / max.		10 <sup>6</sup>				
Number of on-load operations		2 x 10 <sup>7</sup>				
Number of off-load operations		10 <sup>6</sup>				
Operating speed	F	6 ms	10 ms	10 ms	6 ms	6 ms
	O	10 ms	14 ms	14 ms	15 ms	15 ms
Bounce		1 ms				
Insulation coil / contact		3500 V RMS				
Resistance to shock coil / contact		3500 V RMS				
Insulation contact / contact		3500 V RMS (between 2 contacts)				
Ambient temperature storage		-40°C to +80°C				
operating		-20°C to +70°C (1)				
<b>Other characteristics</b>		Screw clamp		Spring clamp		
Body material	grey	UL 94 V0		UL 94 V0		
Wire	Solid wire	0,2 - 4 mm <sup>2</sup> / 24 - 12 AWG		0,2 - 2,5 mm <sup>2</sup> / 24 - 12 AWG		
size	Stranded wire	0,22 - 2,5 mm <sup>2</sup> / 24 - 12 AWG		0,22 - 2,5 mm <sup>2</sup> / 24 - 12 AWG		
Rated wire size		2,5 mm <sup>2</sup> / 12 AWG		2,5 mm <sup>2</sup> / 12 AWG		
Wire stripping length		9 mm .354"		9 mm .354"		
Recommended screwdriver		3,5 mm .137"		3,5 mm .137"		
Protection	storage	IP20 NEMA1		IP20 NEMA1		
Recommended torque	operating	0,4 - 0,6 Nm 3.5 - 5.3 lb.in		0,4 - 0,6 Nm 3.5 - 5.3 lb.in		
Approvals		LRS, CE				
Reference standards		CEI 947-7-1 / CEI 947-1 / CEI 1131-2 (in relevant parts) / CEI 60664-1 / CEM : IRC 1000-4-2, 3, 4, 5, 6.				

(1) Over 55°C, blocks have to be mounted on horizontal rail with 10 mm spacing between each block. For vertical rail mounting use temperature is 15°C less decreased.

#### Max. DC load breaking capacity

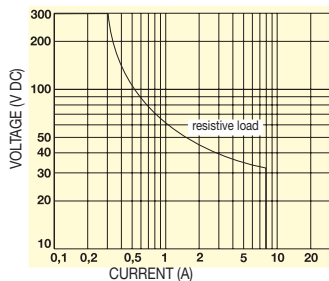

#### Order codes

Description	Type	Order P/N	Packaging	Weight kg
Relay module 1 DPDT low level	RB 122 A-24VAC/DC	1SNA 645 012 R2500	5	0,03
Relay module 1 DPDT low level	RB 122 A-48-60VAC/DC	1SNA 645 040 R1500	5	0,03
Relay module 1 DPDT low level	RB 122 A-115VAC/DC	1SNA 645 041 R0200	5	0,03
Relay module 1 DPDT low level	RB 122 A-230VAC/DC	1SNA 645 013 R2600	5	0,03
Relay module 1 DPDT low level	RBR 122 A-24VAC/DC	1SNA 645 512 R2700	5	0,03
Relay module 1 DPDT low level	RBR 122 A-48-60VAC/DC	1SNA 645 540 R1700	5	0,03
Relay module 1 DPDT low level	RBR 122 A-115VAC/DC	1SNA 645 541 R0400	5	0,03
Relay module 1 DPDT low level	RBR 122 A-230VAC/DC	1SNA 645 513 R2000	5	0,03

#### Accessories

Description	Type	Order P/N	Packaging	Weight kg
End section	BADH V0	1SNA 116 900 R2700	50	
	BADL V0	1SNA 399 903 R0200	50	
	BAM2 V0	1SNA 399 967 R0100	50	
Separator end section	SC 612	1SNA 290 474 R0200	10	
Divisible shunt 10 poles	BJ 612-10	1SNA 290 488 R0100	10	
Test plug DIA. 2 mm	FC2	1SNA 007 865 R2600	10	
Marking method	RC65 RC610	see marking catalogue		

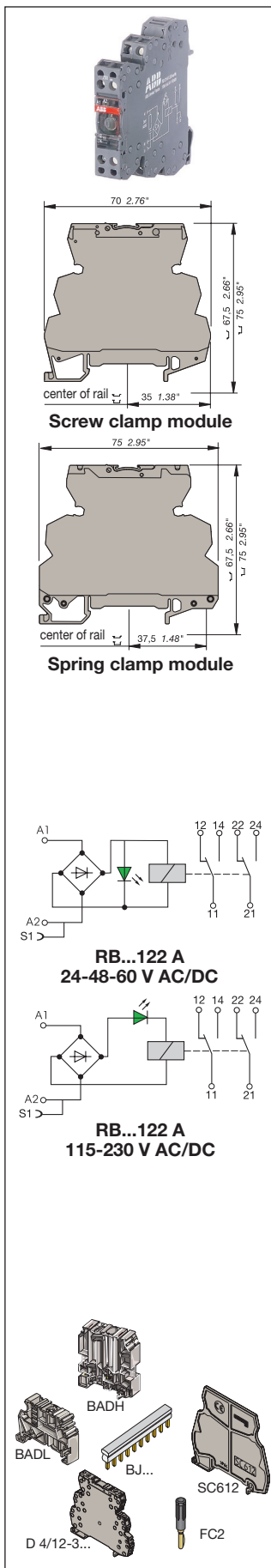

---

## Notes

---

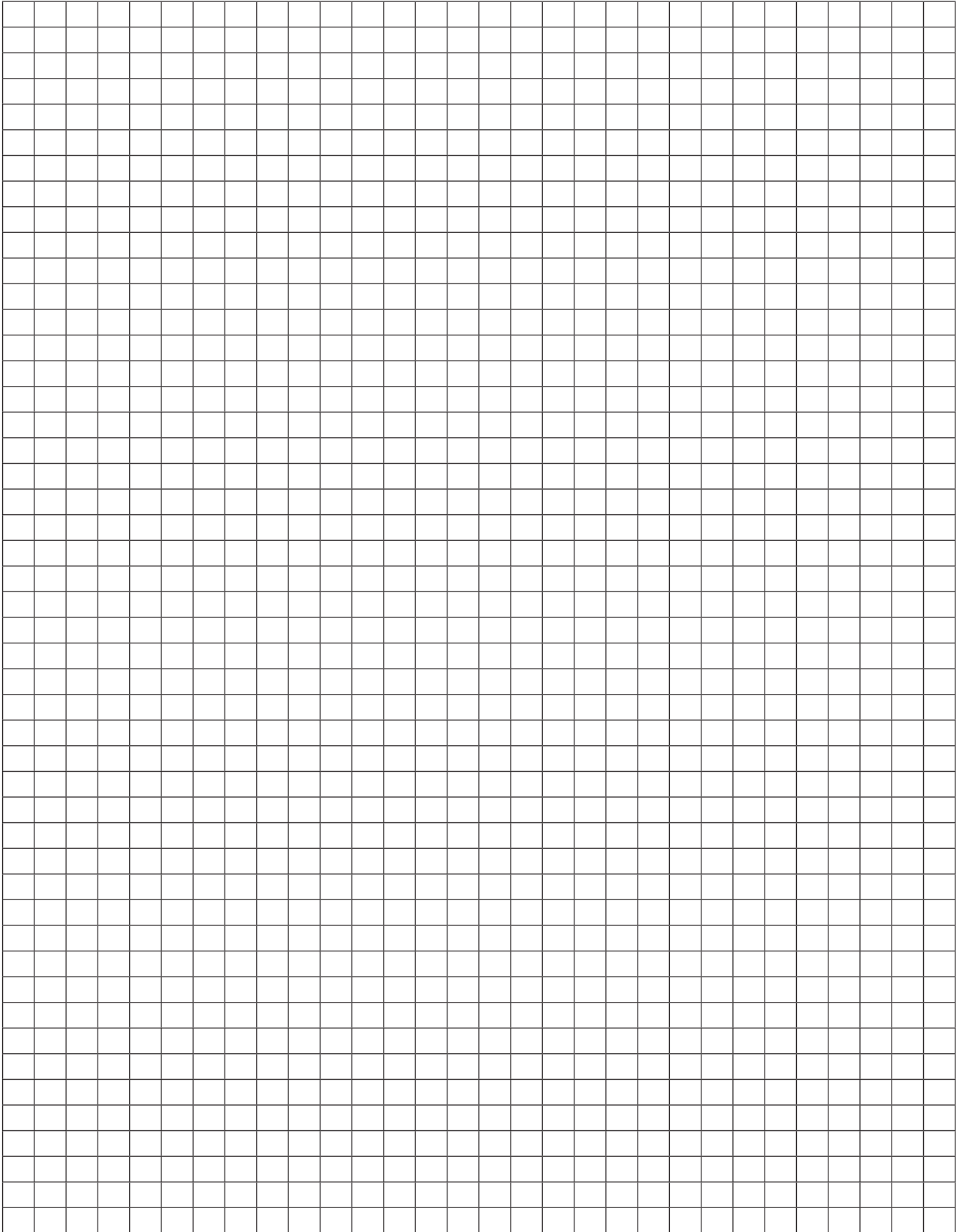

## Contents

Coding principle .....	12
<b>Optocoupler modules</b>	
R600 optocoupler blocks .....	13

# Relays and optocouplers

## Optocouplers

### Coding principle

#### Construction of description type

SERIES	CODE	CONNECTION TYPE	FUNCTION TYPE	MAX. OUTPUT CURRENT (mA)	PARTICULARITIES	INPUT VOLTAGE
R600	O B					
		None : screw R : spring	IC IA OC OA C A IDC ODC OAC		S R None	

#### Function type description :

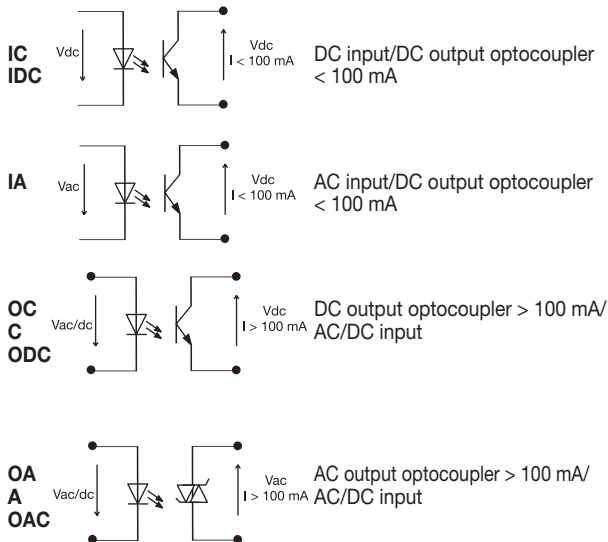

#### Particularities description :

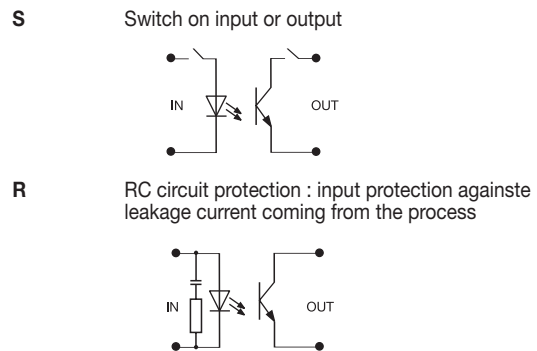

# Relays and optocouplers

## Optocouplers

### R600

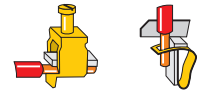

DIN 3

Optocoupler : 5 to 58 V DC output / 100 mA - 6 mm .236" spacing

#### Characteristics

Opto. characteristics	OB...IC 0100					
	INPUT		OUTPUT			
Input voltage +20% -15% on DC, +10% -10% on AC	5 V DC - 12 V DC		24 V DC	48 V AC/DC	60 V AC/DC	115 V AC/DC 230 V AC/DC
Frequency	5 mA   9 mA		4 mA	50 / 60 Hz	50 / 60 Hz	50 / 60 Hz 50 / 60 Hz
Input current AC/DC	4 V   4 V		15 V	4 mA	5 mA	7 mA / 16mA 11.5 mA/25 mA
Pull-in voltage at Is=100%	10 µs / 500 µs		10 µs / 500 µs	25 V	25 V	60 VAC/70 VDC 60 VAC/70 VDC
Switching time C / O	1000 Hz		1000 Hz	5 ms / 20 ms		5 ms / 15 ms
Operating frequency	0,9 mA		1 mA	0,9 mA		1,6 mA
Permissible leakage current						
<b>OUTPUT</b>						
Output voltage	4,5 to 58 VDC					
Output current min.	1 mA					
Output current max.	100 mA					
Output leakage current at Umax.	< 50 µA					
Residual voltage at I max and U rated	1 V					
Frequency on inductive load	1,3 V					
Isolation Input / Output	2500 V RMS					
<b>TEMPERATURE</b>						
Ambient temperature storage	-40°C to +80°C					
operating	-20°C to +70°C (1)					
<b>Other characteristics</b>	Screw clamp			Spring clamp		
Body material	grey UL 94 V0			UL 94 V0		
Wire	Solid wire 0,2 - 4 mm <sup>2</sup> / 24 - 12 AWG			0,2 - 2,5 mm <sup>2</sup> / 24 - 12 AWG		
size	Stranded wire 0,22 - 2,5 mm <sup>2</sup> / 24 - 12 AWG			0,22 - 2,5 mm <sup>2</sup> / 24 - 12 AWG		
Rated wire size	2,5 mm <sup>2</sup> / 12 AWG			2,5 mm <sup>2</sup> / 12 AWG		
Wire stripping length	9 mm .354"			9 mm .354"		
Recommended screwdriver	3,5 mm .137"			3,5 mm .137"		
Protection	IP20 NEMA1			IP20 NEMA1		
Recommended torque	0,4 - 0,6 Nm 3.5 - 5.3 lb.in			0,4 - 0,6 Nm 3.5 - 5.3 lb.in		
Approvals	LRS, CE					
Reference standards	CEI 947-7-1 / CEI 947-1 / CEI 1131-2 (in relevant parts) / CEI 60664-1 / CEM : IRC 1000-4-2, 3, 4, 5, 6.					

(1) Over 55°C, blocks have to be mounted on horizontal rail with 10 mm spacing between each block. For vertical rail mounting use temperature is 15°C less decreased.

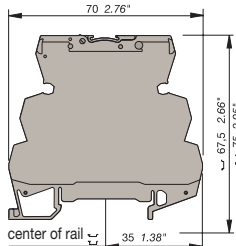

Screw clamp module

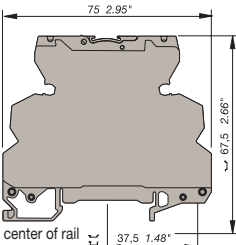

Spring clamp module

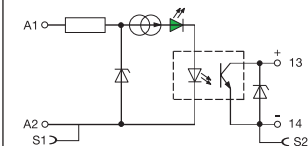

OB...IC 0100 - 5-12 V DC  
115-230 V AC/DC

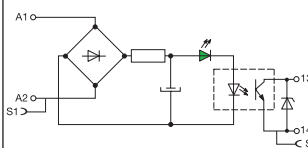

OB...IC 0100  
24 V DC  
24-48-60 V AC/DC

#### Order codes

Description	Type	Order P/N	Packaging	Weight
Optocoupler module 100 mA/DC	OBIC 0100-5-12VDC	1SNA 645 047 R0000	10	0,02
Optocoupler module 100 mA/DC	OBIC 0100-24VDC	1SNA 645 021 R2600	10	0,02
Optocoupler module 100 mA/DC	OBIC 0100-48-60VAC/DC	1SNA 645 049 R1200	10	0,02
Optocoupler module 100 mA/DC	OBIC 0100-115-230VAC/DC	1SNA 645 022 R2700	10	0,02
Optocoupler module 100 mA/DC	OBRIC 0100-5-12VDC	1SNA 645 547 R0200	10	0,02
Optocoupler module 100 mA/DC	OBRIC 0100-24VDC	1SNA 645 521 R2000	10	0,02
Optocoupler module 100 mA/DC	OBRIC 0100-48-60VAC/DC	1SNA 645 549 R1400	10	0,02
Optocoupler module 100 mA/DC	OBRIC 0100-115-230VAC/DC	1SNA 645 522 R2100	10	0,02

#### Accessories

Description	Type	Order P/N	Packaging	Weight
End section	BADH V0	1SNA 116 900 R2700	50	
	BADL V0	1SNA 399 903 R0200	50	
	BAM2 V0	1SNA 399 967 R0100	50	
Separator end section	SC 612	1SNA 290 474 R0200	10	
Divisible shunt 10 poles	BJ 612-10	1SNA 290 488 R0100	10	
Test plug DIA. 2 mm	FC2	1SNA 007 865 R2600	10	
Marking method	RC65 RC610	see marking catalogue		

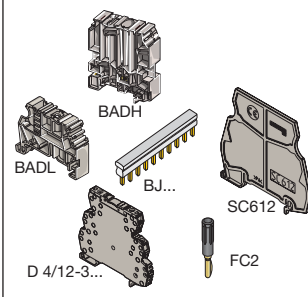

# Relays and optocouplers

## Optocouplers

### R600

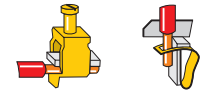

DIN 3

Optocoupler : 5 to 58 V DC output / 2 A - 6 mm .236" spacing

#### Characteristics

Opto. characteristics	OB...OC 1000		OB...OC 1500	OB...OC 1000				
	INPUT							
Input voltage +20% -15% on DC, +10% -10% on AC	5 V DC - 12 V DC		24 V DC	24 V AC/DC	48 V AC/DC	60 V AC/DC	115 V AC/DC	230 V AC/DC
Frequency	5 mA   9 mA		5,4 mA	50 / 60 Hz	50 / 60 Hz	50 / 60 Hz	50 / 60 Hz	50 / 60 Hz
Input current	5 mA   9 mA		5,4 mA	6,3 mA	4 mA	5,1 mA	4,2 mA	4 mA
Pull-in voltage at Is=100%	4 V		12 V	15 V	27 V	27 V	50 V	80 V
Switching time C / O	15 µs / 250 µs		30 µs/400 µs	1 ms/7 ms	5 ms/20 ms	5 ms/20 ms	500 µs/10 ms	1 ms / 15 ms
Operating frequency	2000 Hz		1000 Hz	60 Hz	20 Hz	50 Hz	50 Hz	35 Hz
Permissible leakage current	1 mA		0,8 mA	0,9 mA	1 mA	1 mA	0,3 mA	0,3 mA
<b>OUTPUT</b>								
Output voltage	4,5 to 58 VDC							
Output current min.	1 mA							
Output current max.	2 A							
Output leakage current at Umax.	< 50 µA							
Residual voltage at I max and U rated	typical 0,1 V max. 0,5 V							
Frequency on inductive load								
Isolation Input / Output	2500 V RMS							
<b>TEMPERATURE</b>								
Ambient temperature storage	-40°C to +80°C							
operating	-20°C to +70°C (1)							
<b>Other characteristics</b>								
Body material	Screw clamp grey				Spring clamp			
Wire size	Solid wire UL 94 V0 0,2 - 4 mm <sup>2</sup> / 24 - 12 AWG				UL 94 V0 0,2 - 2,5 mm <sup>2</sup> / 24 - 12 AWG			
Stranded wire size	0,22 - 2,5 mm <sup>2</sup> / 24 - 12 AWG				0,22 - 2,5 mm <sup>2</sup> / 24 - 12 AWG			
Rated wire size	2,5 mm <sup>2</sup> / 12 AWG				2,5 mm <sup>2</sup> / 12 AWG			
Wire stripping length	9 mm .354"				9 mm .354"			
Recommended screwdriver	3,5 mm .137"				3,5 mm .137"			
Protection	IP20 NEMA1				IP20 NEMA1			
Recommended torque	0,4 - 0,6 Nm 3.5 - 5.3 lb.in				0,4 - 0,6 Nm 3.5 - 5.3 lb.in			
Approvals	LRS, CE							
Reference standards	CEI 947-7-1 / CEI 947-1 / CEI 1131-2 (in relevant parts) / CEI 60664-1 / CEM : IRC 1000-4-2, 3, 4, 5, 6.							

(1) Over 55°C, blocks have to be mounted on horizontal rail with 10 mm spacing between each block. For vertical rail mounting use temperature is 15°C less decreased.

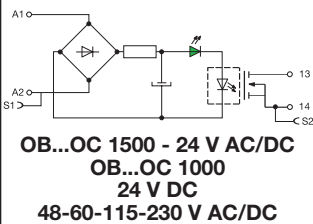
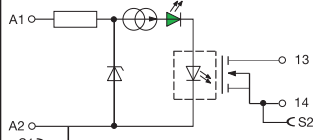
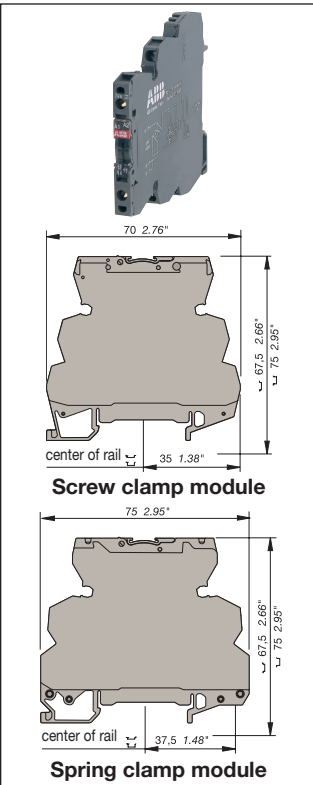

#### Order codes

Description	Type	Order P/N	Packaging	Weight
Optocoupler module 2 A/DC	OBOC 1000-5-12VDC	1SNA 645 050 R1700	10	0,02
Optocoupler module 2 A/DC	OBOC 1000-24VDC	1SNA 645 051 R0400	10	0,02
Optocoupler module 2 A/DC	OBOC 1500-24VAC/DC	1SNA 645 025 R2200	10	0,02
Optocoupler module 2 A/DC	OBOC 1000-48-60VAC/DC	1SNA 645 053 R0600	10	0,02
Optocoupler module 2 A/DC	OBOC 1000-115VAC/DC	1SNA 645 054 R0700	10	0,02
Optocoupler module 2 A/DC	OBOC 1000-230VAC/DC	1SNA 645 026 R2300	10	0,02
Optocoupler module 2 A/DC	OBROC 1000-5-12VDC	1SNA 645 550 R1100	10	0,02
Optocoupler module 2 A/DC	OBROC 1000-24VDC	1SNA 645 551 R0600	10	0,02
Optocoupler module 2 A/DC	OBROC 1500-24VAC/DC	1SNA 645 525 R2400	10	0,02
Optocoupler module 2 A/DC	OBROC 1000-48-60VAC/DC	1SNA 645 553 R0000	10	0,02
Optocoupler module 2 A/DC	OBROC 1000-115VAC/DC	1SNA 645 554 R0100	10	0,02
Optocoupler module 2 A/DC	OBROC 1000-230VAC/DC	1SNA 645 526 R2500	10	0,02

#### Accessories

Description	Type	Order P/N	Packaging	Weight
End section	BADH V0	1SNA 116 900 R2700	50	
	BADL V0	1SNA 399 903 R0200	50	
	BAM2 V0	1SNA 399 967 R0100	50	
Separator end section	SC 612	1SNA 290 474 R0200	10	
Divisible shunt 10 poles	BJ 612-10	1SNA 290 488 R0100	10	
Test plug DIA. 2 mm	FC2	1SNA 007 865 R2600	10	
Marking method	RC65 RC610	see marking catalogue		

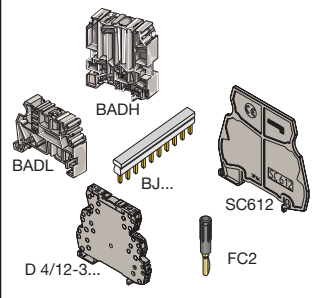



# Relays and optocouplers

## Optocouplers

### R600

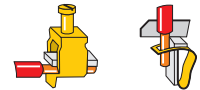

DIN 3

Optocoupler : 5 to 58 V DC output / 5 A - 6 mm .236" spacing

#### Characteristics

Opto. characteristics	OB...OC 5000			
	24 V DC	115 V AC/DC	230 V AC/DC	50 / 60 Hz
<b>INPUT</b>				
Input voltage +20% -15% on DC, +10% -10% on AC	24 V DC	115 V AC/DC	230 V AC/DC	50 / 60 Hz
Frequency		50 / 60 Hz	50 / 60 Hz	
Input current	5,4 mA	4,2 mA	4 mA	
Pull-in voltage at Is=100%	12 V	50 V	80 V	
Switching time C / O	30 µs/400 µs	500 µs/10 ms	1 ms / 15 ms	
Operating frequency	1000 Hz	50 Hz	35 Hz	
Permissible leakage current	0,8 mA	0,3 mA	0,3 mA	
<b>OUTPUT</b>				
Output voltage	4,5 to 58 VDC			
Output current min.	1 mA			
Output current max.	5 A			
Output leakage current at Umax.	< 50 µA			
Residual voltage at I max and U rated	typical 0,1 V max. 0,5 V			
Frequency on inductive load				
Isolation Input / Output	2500 V RMS			
<b>TEMPERATURE</b>				
Ambient temperature storage	-40°C to +80°C			
operating	-20°C to +70°C (1)			
<b>Other characteristics</b>	Screw clamp	Spring clamp		
Body material	grey UL 94 V0	UL 94 V0		
Wire size	Solid wire 0,2 - 4 mm <sup>2</sup> / 24 - 12 AWG	0,2 - 2,5 mm <sup>2</sup> / 24 - 12 AWG		
size	Stranded wire 0,22 - 2,5 mm <sup>2</sup> / 24 - 12 AWG	0,22 - 2,5 mm <sup>2</sup> / 24 - 12 AWG		
Rated wire size	2,5 mm <sup>2</sup> / 12 AWG	2,5 mm <sup>2</sup> / 12 AWG		
Wire stripping length	9 mm .354"	9 mm .354"		
Recommended screwdriver	3,5 mm .137"	3,5 mm .137"		
Protection	IP20 NEMA1	IP20 NEMA1		
Recommended torque	0,4 - 0,6 Nm 3.5 - 5.3 lb.in	0,4 - 0,6 Nm 3.5 - 5.3 lb.in		
Approvals	LRS, CE			
Reference standards	CEI 947-7-1 / CEI 947-1 / CEI 1131-2 (in relevant parts) / CEI 60664-1 / CEM : IRC 1000-4-2, 3, 4, 5, 6.			

(1) Over 55°C, blocks have to be mounted on horizontal rail with 10 mm spacing between each block. For vertical rail mounting use temperature is 15°C less decreased.

**Screw clamp module**  
70 2.76"  
67,5 2.66"  
75 2.95"  
center of rail 35 1.38"

**Spring clamp module**  
75 2.95"  
67,5 2.66"  
75 2.95"  
center of rail 37,5 1.48"

**OB...OC 5000**  
24 V DC  
24-48-60-115-230 V AC/DC

BADH  
BADL  
BJ...  
SC612  
D 4/12-3...  
FC2

#### Order codes

Description	Type	Order P/N	Packaging	Weight kg
Optocoupler module 5 A/DC	OBOC 5000-24VDC	1SNA 645 024 R2100	10	0,02
Optocoupler module 5 A/DC	OBOC 5000-115VAC/DC	1SNA 645 058 R1300	10	0,02
Optocoupler module 5 A/DC	OBOC 5000-230VAC/DC	1SNA 645 059 R1400	10	0,02
Optocoupler module 5 A/DC	OBROC 5000-24VDC	1SNA 645 524 R2300	10	0,02
Optocoupler module 5 A/DC	OBROC 5000-115VAC/DC	1SNA 645 558 R1500	10	0,02
Optocoupler module 5 A/DC	OBROC 5000-230VAC/DC	1SNA 645 559 R1600	10	0,02

#### Accessories

Description	Type	Order P/N	Packaging	Weight kg
End section	BADH V0	1SNA 116 900 R2700	50	
	BADL V0	1SNA 399 903 R0200	50	
	BAM2 V0	1SNA 399 967 R0100	50	
Separator end section	SC 612	1SNA 290 474 R0200	10	
Divisible shunt 10 poles	BJ 612-10	1SNA 290 488 R0100	10	
Test plug DIA. 2 mm	FC2	1SNA 007 865 R2600	10	
Marking method	RC65 RC610	see marking catalogue		

# Relays and optocouplers

## Optocouplers

### R600

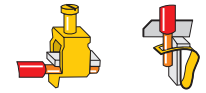

DIN 3

Optocoupler : 24 to 400 V AC output / 2 A max. - 6 or 12 mm spacing

#### Characteristics

Opto. characteristics	OB...OA 1000							OB...OA 2000
	24 V DC	48 V AC/DC	60 V AC/DC	115 V AC/DC	230 V AC/DC	24 V DC		
<b>INPUT</b>								
Input voltage +20% -15% on DC, +10% -10% on AC	24 V DC	48 V AC/DC	60 V AC/DC	115 V AC/DC	230 V AC/DC	24 V DC		
Frequency		50 / 60 Hz	50 / 60 Hz	50 / 60 Hz	50 / 60 Hz			
Input current	3,6 mA	4,3 mA	5,5 mA	4,15 mA	4,6 mA	3,6 mA		
Pull-in voltage at Is=100%	14 V	15 V	18 V	60 V	135 V	14 V		
Switching time C / O	150 µs/1ms	3 ms / 30 ms		2,2 ms/18 ms	2,5 ms/25 ms	150 µs/1 ms		
Operating frequency	500 Hz		20 Hz	25 Hz	20 Hz	500 Hz		
Permissible leakage current	1 mA		1 mA	1 mA	1 mA	1 mA		
<b>OUTPUT</b>								
Output voltage	24 to 400 V AC							
Frequency	50 / 60 Hz							
Output current min.	25 mA							
Output current max.	1 A						2 A	
Output leakage current at Umax.	< 0,5 mA							
Residual voltage at I max and U rated	typical 1 V max. 1,6 V							
Frequency on inductive load	2500 V RMS							
Isolation Input / Output	2500 V RMS							
<b>TEMPERATURE</b>								
Ambient temperature storage	- 40°C to + 80°C							
operating	-20°C to +70°C (1)							
<b>Other characteristics</b>	Screw clamp			Spring clamp				
Body material	grey			grey				
Wire	Solid wire			Solid wire				
size	0,2 - 4 mm <sup>2</sup> / 24 - 12 AWG			0,2 - 2,5 mm <sup>2</sup> / 24 - 12 AWG				
Rated wire size	Stranded wire			Stranded wire				
Wire stripping length	0,22 - 2,5 mm <sup>2</sup> / 24 - 12 AWG			0,22 - 2,5 mm <sup>2</sup> / 24 - 12 AWG				
Recommended screwdriver	2,5 mm <sup>2</sup> / 12 AWG			2,5 mm <sup>2</sup> / 12 AWG				
Protection	9 mm .354"			9 mm .354"				
Recommended torque	3,5 mm .137"			3,5 mm .137"				
Approvals	IP20 NEMA1			IP20 NEMA1				
Reference standards	0,4 - 0,6 Nm 3.5 - 5.3 lb.in			0,4 - 0,6 Nm 3.5 - 5.3 lb.in				

(1) Over 55°C, blocks have to be mounted on horizontal rail with 10 mm spacing between each block. For vertical rail mounting use temperature is 15°C less decreased.



#### Order codes

Description	Type	Order P/N	Packaging	Weight kg
Optocoupler module 1 A/AC 6 mm spac.	OBOA 1000-24VDC	1SNA 645 027 R2400	10	0,03
Optocoupler module 1 A/AC 6 mm spac.	OBOA 1000-48-60VAC/DC	1SNA 645 061 R0600	10	0,03
Optocoupler module 1 A/AC 6 mm spac.	OBOA 1000-115VAC/DC	1SNA 645 062 R0700	10	0,03
Optocoupler module 1 A/AC 6 mm spac.	OBOA 1000-230VAC/DC	1SNA 645 028 R0500	10	0,03
Optocoupler module 2 A/AC 12 mm spac.	OBOA 2000-24VDC	1SNA 645 029 R0600	5	0,03
Optocoupler module 1 A/AC 6 mm spac.	OBROA 1000-24VDC	1SNA 645 527 R2600	10	0,03
Optocoupler module 1 A/AC 6 mm spac.	OBROA 1000-48-60VAC/DC	1SNA 645 561 R0000	10	0,03
Optocoupler module 1 A/AC 6 mm spac.	OBROA 1000-115VAC/DC	1SNA 645 562 R0100	10	0,03
Optocoupler module 1 A/AC 6 mm spac.	OBROA 1000-230VAC/DC	1SNA 645 528 R0700	10	0,03
Optocoupler module 2 A/AC 12 mm spac.	OBROA 2000-24VDC	1SNA 645 529 R0000	5	0,03

#### Accessories

Description	Type	Order P/N	Packaging	Weight kg
End section	BADH V0	1SNA 116 900 R2700	50	
	BADL V0	1SNA 399 903 R0200	50	
	BAM2 V0	1SNA 399 967 R0100	50	
Separator end section	SC 612	1SNA 290 474 R0200	10	
Divisible shunt 10 poles	BJ 612-10	1SNA 290 488 R0100	10	
Test plug DIA. 2 mm	FC2	1SNA 007 865 R2600	10	
Marking method	RC65 RC610	see marking catalogue		

---

# Notes

---

A large grid of graph paper, consisting of 20 columns and 30 rows of small squares, intended for taking notes.

# Contact

## **ABB Canada**

Low Voltage Products  
2117, 32<sup>nd</sup> Avenue  
Lachine, Quebec H8T 3J1

Tel. : 514 420 3100  
Toll free : 800 567 0283

[www.abb.ca/lowvoltage](http://www.abb.ca/lowvoltage)

## **Note:**

We reserve the right to make technical changes or modify the contents of this document without prior notice. With regard to purchase orders, the agreed particulars shall prevail. ABB Canada does not accept any responsibility whatsoever for potential errors or possible lack of information in this document.

We reserve all rights in this document and in the subject matter and illustrations contained therein. Any reproduction, disclosure to third parties or utilization of its contents – in whole or in parts – is forbidden without prior written consent of ABB Canada.

Copyright© 2010 ABB  
All rights reserved

1SXP110001C0203 - Canada (October 2010)