

# TRIO-MASS

Mass Flowmeter based on the Coriolis Principle for the Simultaneous Measurement of Mass, Density and Temperature

D184S068U02 Rev. 01 / 06.2001



Fig. 1

## ■ Basic Components

- Flowmeter Primary “B” 1/4” [DN 6] to “L” 6” [DN 150]
- Converter in a Compact or Remote Design
- Selectable process connections and pressure ratings
- Fluid wetted parts made of stainless steel or Hastelloy C4

## ■ Technical Features

- Measurement of mass flow, density and temperature
- High measurement accuracy
  - Mass to 0.15 % of rate
  - Density to 1 g/l
- High fluid temperature ranges to 180 °C
- Two current outputs and one pulse output

## ■ Applications

- Chemicals, e.g. solvents, deionized water
- Petrochemicals, e.g. benzene, crude products
- Food Industry, e.g. oils, fats, juices
- Pharmaceuticals e.g. cosmetics, chemicals
- Paper Industry, e.g. additives
- Power Plants, e.g. heating oil, hot water

Coriolis-Mass Flowmeters are utilized for high accuracy mass flow and density measurements. The fluid need not be electrically conductive.

**ABB**

**Principle of Operation**

TRIO-MASS is the economical and uncomplicated ABB Mass Flowmeter with a new integrally or remote mounted DSP converter. The Compact Design reduces installation and wiring costs. The flowrate information is displayed locally plus an installation in your system may also save additional space.

The TRIO-MASS operates according to the Coriolis Principle. The design offers the following advantages:

- Space-saving, rugged design.
- Wide flowmeter size range from 1/4" to 6" / DN 6 to DN 150.
- Numerous process connection options.
- Two separate current outputs for flowrate and density in conjunction with a pulse output.
- Contact in- and output.
- HART-Protocol.
- Ex-Approval: The Ignition Protection Type for the output circuits can be selected as „i“ or „e“ and is determined by the circuits which are connected to the outputs. The Ignition Protection Type can be changed after the installation has been completed. The contact outputs can be configured as NAMUR-Outputs by the user.
- Allowable fluid temperature 180 °C.
- Lighted, 2 line display plus data entry without opening the meter using a Magnet Stick.

**Mass Converter with Digital Signal Processor (DSP)**

The converter for the compact TRIO-MASS incorporates a digital signal processor (DSP) with which it is possible to measure the mass flow and density value to the highest precision. The Coriolis sensor signals are immediately converted into digital information without any intermediate analog steps.

Excellent long term stability and reliability together with fast signal processing are the results of the new DSP-Converter.

Self diagnostic functions for the flowmeter primary and the converter coupled with absolute zero stability are the essential advantages, which are required if reliance on the measurements is to be assured.

The TRIO-MASS converter provides advantages to the user especially

- when mass flowrate is to be metered at the highest accuracy.
- when the fluid density must be determined.
- when the components of a recipe are to be mixed together.
- when metering non-conductive fluids or highly viscous, solids loaded liquids.
- in batch filling systems.

**Principle of Operation**

When a mass flows through a vibrating pipe, Coriolis forces are generated which bend and twist the pipe. These very small pipe deformations are measured by optimally mounted sensors and electronically evaluated. Because the measured phase shift of the sensor signals is proportional to the mass flowrate, the Coriolis Mass Flowmeter measures the mass flowrate in the flowmeter directly. The metering principle is independent of the density, temperature, viscosity, pressure and conductivity.

The metering tubes always vibrate at resonance. The resonant frequency at the operating conditions is a function of the meter tube geometry, the characteristics of the flowmeter materials and the mass of the fluid in the metering tube, which is also vibrating. It provides an accurate measure of the density of the fluid being metered. Summarizing, it is possible to simultaneously measure the mass flowrate, fluid density and temperature with the Coriolis Mass Flowmeter.

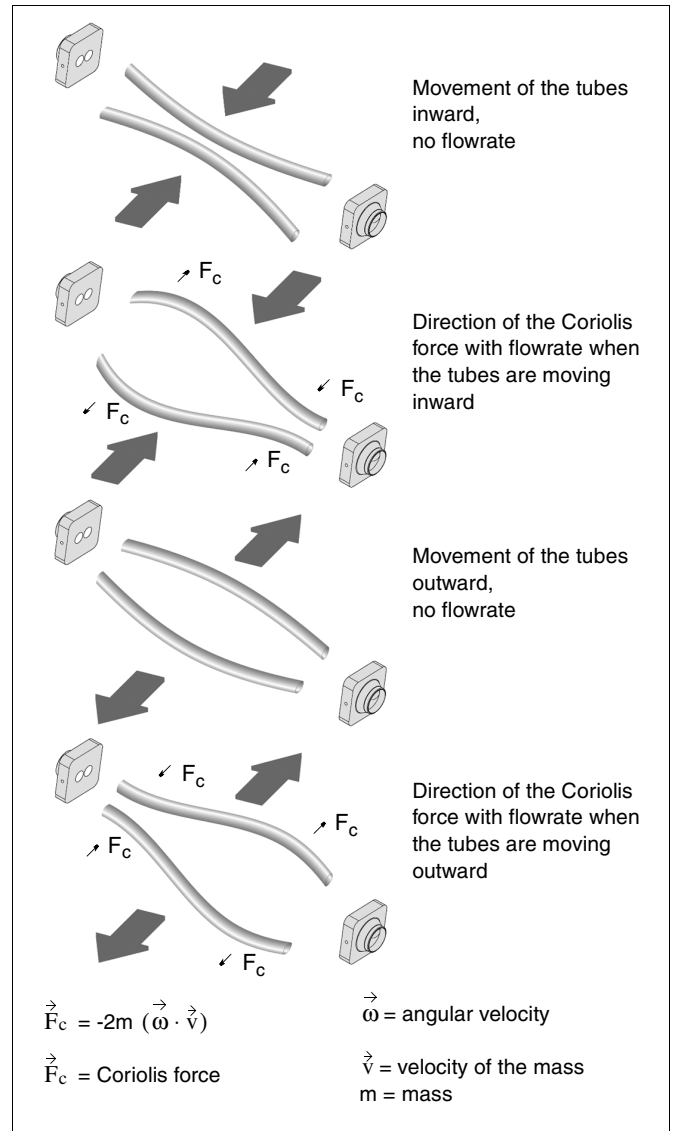

Fig. 2 Simplified Representation of the Coriolis Forces

## System Design

The flowmeter primary consists of two one piece, formed meter tubes arranged in parallel. A twist and bend resistant mounting structure which connects the in- and outlet of the flowmeter is especially designed to isolate the meter tube from external forces and moments.

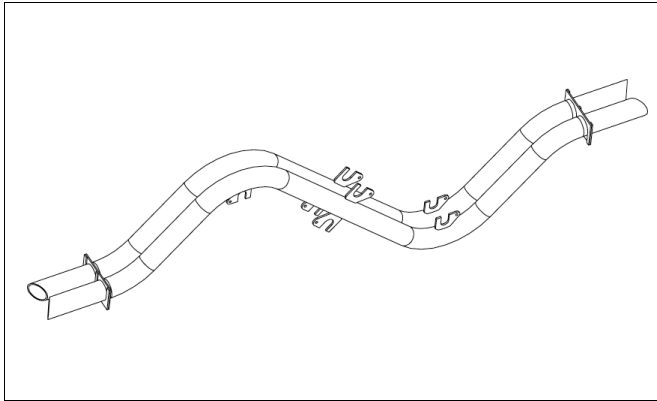

Fig. 3 TRIO-MASS Parallel Meter Tube Design

The in- and outlet ends of the meter tube are welded to flow splitters. Therefore there is no direct coupling to the process connections. This approach minimizes the effects of external vibrations on the measurements.

Long life is assured by elimination of weld seams in the highly stressed areas and by hard silver soldering, under vacuum, the mounts for the meter tube, driver and sensor. Exceptional long term stability is assured by vacuum stress relieving the meter tubes.

Straightforward installations, wide flow ranges and a variety of process connections and last, but not least, the quick amortization of the costs make the TRIO-MASS an instrument which can be optimally applied in production processes.

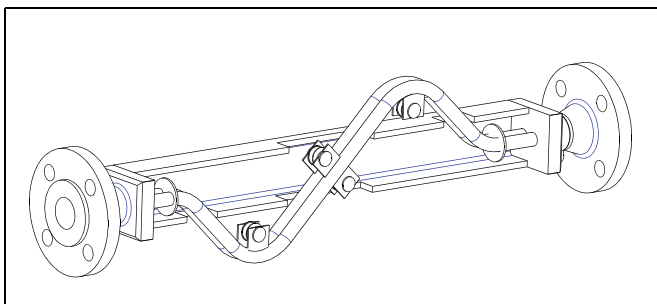

Fig. 4 Double Tube Flowmeter Primary TRIO-MASS

**Assembly and Installation Flowmeter Primary**

**Inspection**

Before installing the flowmeter primary, check for mechanical damage due to possible improper handling during shipment. All claims for damage are to be made promptly to the shipper.

**Installation Requirements/System Design Information**

The TRIO-MASS is suitable for in- and outdoor installations. The standard instrument meets the requirements of Protection Class IP 67. The primary is bidirectional and can be installed in any orientation. It is important to assure that the meter tubes are always completely filled with fluid.

The corrosion resistance of the fluid wetted materials must be evaluated.

The following points are to be considered during installation:

The preferred flow direction is indicated by the arrow on the flowmeter primary. Flow in this direction will be indicated as positive (a forward/reverse flow calibration is available as an option).

**Installation Orientation**

- The TRIO-MASS operates in all orientations. The optimal installation orientation is vertical with the flow upwards.

**Supports**

- In order to support the weight of the flowmeter primary and to assure reliable measurements when external effects exist (e.g. vibrations), the primary should be installed in rigid pipelines. Two supports or hangers should be installed symmetrically and stress free in close proximity to the process connections.

**Shut Off Devices**

- To conduct a system zero adjustment, shut off devices are required in the pipeline.
  - in horizontal installations at the outlet
  - in vertical installations at the inlet
- When possible, shut off devices should be installed both up- and downstream of the flowmeter primary.

**Inlet Straight Sections**

- The mass flowmeter does not require any flow conditioning inlet straight sections. Care should be exercised to assure that any valves, gates, sight glasses etc. do not cavitate and are not set into vibration by the flowmeter primary.

**System Design Information**

- The presence of gas bubbles in the fluid can result in erroneous measurements, particularly in the density measurement. Therefore the flowmeter primary should not be installed at the highest point in the system. Advantageous are installations in low pipeline sections, at the bottom of a U-section in the pipeline (invert).
- Long drop lines downstream from the flowmeter primary should be avoided to prevent the meter tube from draining.
- The connecting pipelines should be axially centered to assure a stress free installation.
- The flowmeter primary should not come in contact with any other objects. Attachments to the housing are not permissible.
- When the cross-section of the connecting pipeline is larger than the flowmeter primary size, suitable standard reducers can be installed.

- If strong vibrations exist in the pipeline they should be damped using elastic pipeline elements. The damping devices must be installed outside of the supported flowmeter section and outside of the section between the shut off devices. The direct connection of flexible elements to the flowmeter primary should be avoided
- Care should be exercised to assure that any dissolved gases, which are present in many liquids, do not outgas. The back pressure at the outlet should be at least 0.2 bar.
- Assure that operation below the vapor pressure cannot occur when a vacuum exists in the meter tube or for fluids which boil readily.
- The flowmeter primary should not be installed in the vicinity of strong electromagnetic fields, e.g. near motors, pumps, transformers etc.
- When operating more than one meter in one or multiple interconnected pipelines, the meter primaries should be spaced distant from each other or the pipelines should be decoupled to prevent cross talk.

**Zero Adjustment**

- In order to adjust the zero under operating conditions it must be possible to reduce the flowrate „ZERO“ while the meter tube is completely filled. A bypass line is optimal when the process cannot be shut down. It is important for accurate measurements that during the zero adjustment there are no gas bubbles in the flowmeter primary. It is also important that the pressure and temperature in the meter tube be the same as that which exists during operation.

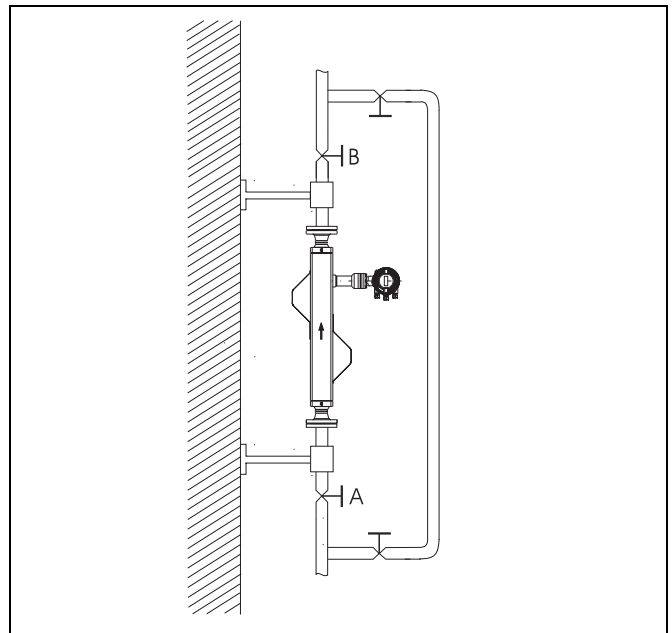

Fig. 5 Zero Adjustment with a By-Pass Line

**Installation Instructions**

**Vertical Installations**

The optimal installation orientation is a vertical installation with an upward flow as shown in the following figure. This has the advantage that any solids contained in the fluid will settle downward and gas bubbles will move upward out of the meter tube when the flow-rate is zero. Additionally, it is easy to drain the meter tube. Deposits can thereby be avoided.

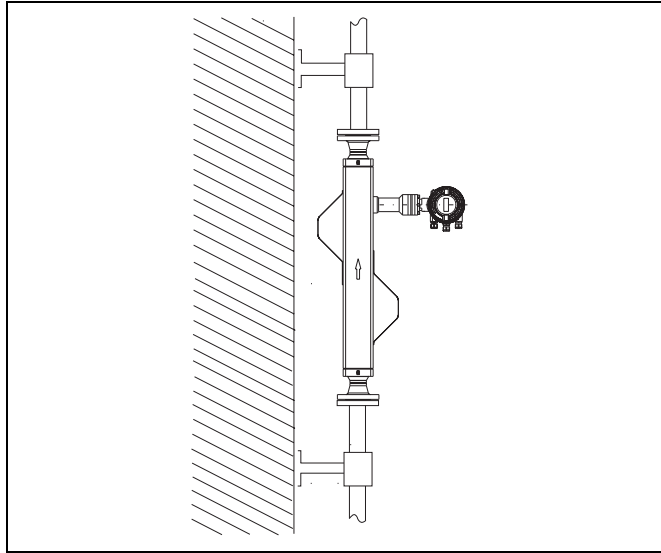

Fig. 6 Vertical Installation, Self-Draining (upward flow)

**Horizontal Orientation**

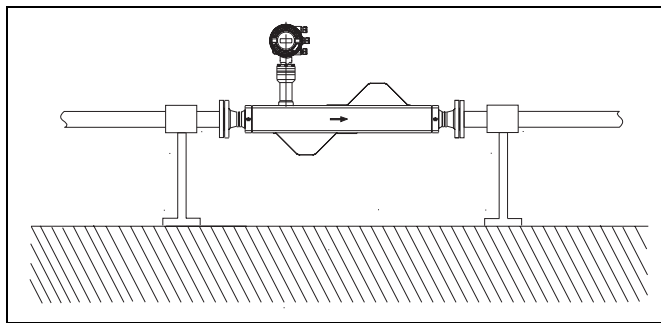

Fig. 7 Horizontal Installation

**Horizontal Installation, Self-Draining**

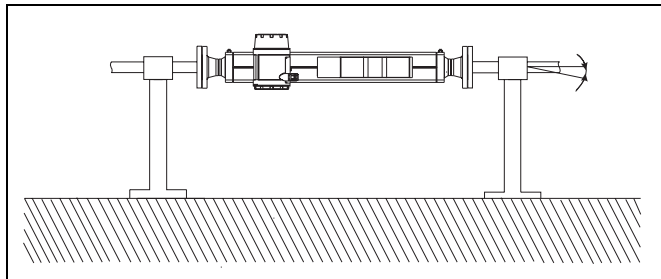

Fig. 8 Horizontal Installation, Self-Draining,  $\alpha 2 - 4^\circ$

**Installation in a Drop Line**

The installation recommendation shown in the following figure is only possible if a pipeline reduction or orifice with a smaller cross-section can be installed to prevent the flowmeter primary from being partially draining during the measurements.

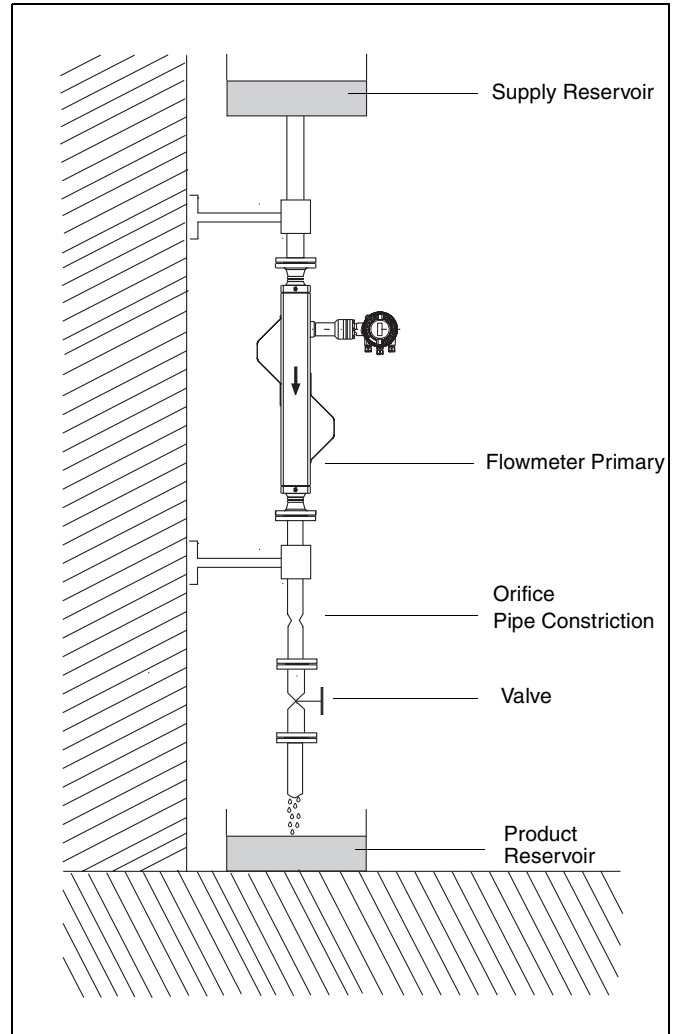

Fig. 9 Installation in a Drop Line

### Difficult Installation Locations

The accumulation of air or gas bubbles in the meter tube can lead to increased inaccuracies. Some difficult installations are shown in the following figure.

Installations at the highest point in the system (Figure A) can result in the formation of air pockets which can lead to appreciable inaccuracies.

Another difficult installation condition is immediately upstream of a free discharge (Figure B) in a drop line.

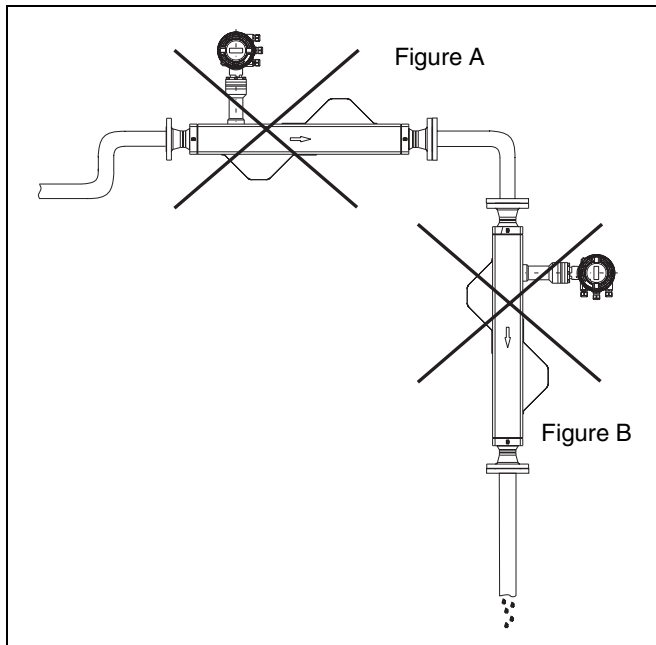

Fig. 10 Difficult Installation Conditions

- ! Note: Check that the coordination between the flowmeter primary and the converter is correct. The instruments which belong together have the same end characters on the Instrument Tag, e.g., X001 with Y001 or X002 with Y002.

### Pressure Drop

The pressure drop through the instrument is a function of the properties of the fluid and the flowrate. The Selection Program FLOWCALC can be used to calculate the pressure drop.

**Specifications Flowmeter Primary TRIO-MASS**



Fig. 11 Flowmeter Primary TRIO-MASS

**Meter Sizes**

“B”(1/4”[DN6]);“C”(3/8”[DN10]);“D”(1/2”[DN15]);  
 “E” (3/4”[DN20]); “F”(1”[DN25]);“G”(1-1/2”[DN40]);  
 “H”(2”[DN50]); “I”(2-1/2”[DN65]);“J”(3”[DN80]);“  
 K”(4”[DN100]);“L”(6”[DN150])

**Flow Ranges**

Meter Size		Nominal Flow Range [Q <sub>nom</sub> ]-[kg/min]		Nominal Flow Range in [t/h]		Max. Flow Range [Q <sub>max</sub> ]-[kg/min]	
Inch	DN						
“B”	1/4	6	0 to 11	0 to 0.66	0 to 13		
“C”	3/8	10	0 to 18	0 to 1.08	0 to 25		
“D”	1/2	15	0 to 45	0 to 2.7	0 to 60		
“E”	3/4	20	0 to 75	0 to 4.5	0 to 100		
“F”	1	25	0 to 125	0 to 7.5	0 to 160		
“G”	1-1/2	40	0 to 365	0 to 21.9	0 to 475		
“H”	2	50	0 to 710	0 to 42.6	0 to 920		
“I”	2-1/2	65	0 to 1450	0 to 87	0 to 1890		
“J”	3	80	0 to 1890	0 to 113.4	0 to 2460		
“K”	4	100	0 to 3200	0 to 192	0 to 4160		
“L”	6	150	0 to 8500	0 to 510	0 to 11000		

**Accuracy, Flowrate**

± 0.4 % of rate ± 0.02 % of Q<sub>max</sub>  
 ± 0.25 % of rate ± 0.02 % of Q<sub>max</sub>  
 ± 0.15 % of rate ± 0.01 % of Q<sub>max</sub>

**Reproducibility, Flowrate**

0.1 % of rate for nom. deviation ± 0.15 %  
 0.15 % of rate for nom. deviation ± 0.25 % and 0.4 %

**Measurement Range, Density**

0.5 kg/dm<sup>3</sup> to 3.5 kg/dm<sup>3</sup>

**Accuracy, Density**

Standard calibration ± 5 g/l  
 Expanded density calibration ± 1 g/l

**Reproducibility, Density**

± 0.1 g/l

**Materials**

Fluid wetted parts  
 Stainless steel 316Ti / 1.4571  
 Hastelloy C4/2.4610  
 Housing  
 Stainless steel 304 / 1.4301

**Fluid Temperature**

Standard: -50 °C to 180 °C; EEx: -20 °C to +180 °C

**Ambient Temperature**

-25 °C to +60 °C; EEx: -20 °C to +60 °C

**Process Connections**

Flanges DIN/ANSI  
 Tri-Clamp ISO 2852  
 Food Industry fittings DIN 11851

The max. allowable operating pressure is a function of the process connection type, the fluid temperature, the bolts and the gaskets.

**Pressure Ratings**

PN 16, PN 40, PN 100  
 CL 150, CL 300, CL 600

**Accuracy, Temperature**

-50 °C to +180 °C < 1.0 °C  
 -20 °C to +120 °C ± 0.5 °C

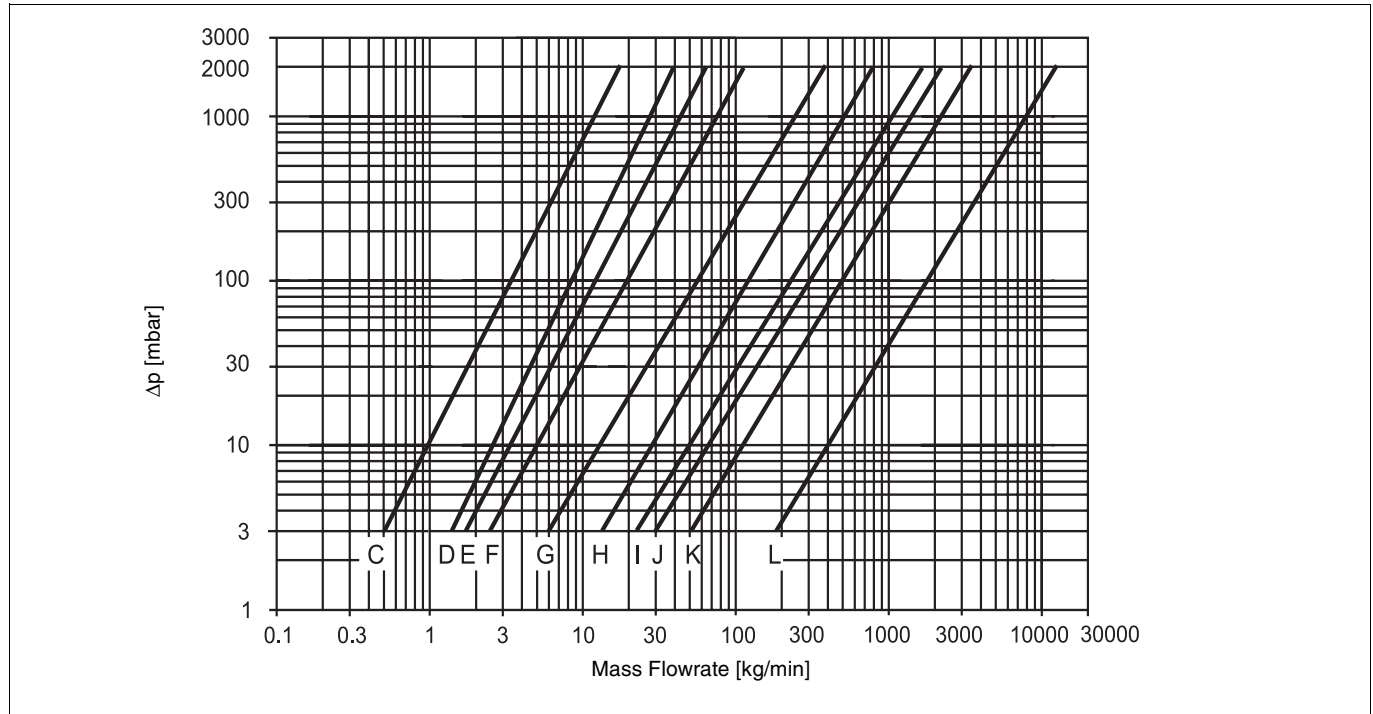
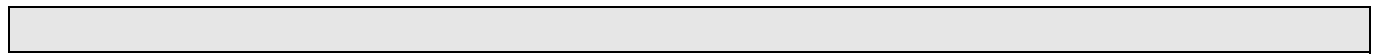

Fig. 12 Pressure Drop Curve TRIO-MASS

**Viscosity Range**

Max. dyn. viscosity: ≤ 1 Pas (=1000 mPas = 1000 cP)  
 For higher viscosities, please contact an ABB-Representative.

**Ex-Approvals**

**EU-Type Examination Certificate:**

TÜV 99 ATEX 1443 X  
 II 2G EEx emd [ib] IIC T6: MC27 (≤ 1-1/2" [DN 40])  
 II 1/2G EEx emd [ib] IIC T6: MC27 (2" - 6" [DN 50 - DN 150])

The interior for meter sizes „H“ (2"[DN50]) to „L“(6"[DN 150]) corresponds to Category 1 (Zone 0).

**Maximum Allowable Fluid Temperatures as a Function of the Ambient Temperature, Temperature Class and the Flowmeter Size**

Meter Size	1/4" - 1/2" [DN 6 - DN 15]			3/4" - 6" [DN 20 - DN 150]		
	Ambient temperature	40 °C	50 °C	60 °C	40 °C	50 °C
Temperature Class						
T2	150 °C	-	-	180 °C	-	-
T3	140 °C	140 °C	80 °C	165 °C	140 °C	-
T4	75 °C	75 °C	75 °C	100 °C	100 °C	80 °C
T5	40 °C	40 °C	40 °C	65 °C	65 °C	65 °C
T6	25 °C	25 °C	25 °C	50 °C	50 °C	50 °C

The values also apply to insulated Mass Flowmeters.

**Specifications Converter**



Fig. 13 Converter TRIO-MASS

**Measurement Range**

Infinitely adjustable

**Protection Class**

IP 67

**Electrical Connections**

Cable connectors M20 x 1.5

Max. signal cable length for remote design 300 m

**Supply Power**

High voltage 85 to 253 V AC

Low voltage 24 V AC / 24 V DC

Frequency 47 to 64 Hz

**Power**

< 15 VA

**Response Time**

For a 0 - 99 % step change (corresp.  $5 \tau$ )  $\geq 1$  s

**Ambient Temperature**

-20 °C to 60 °C

**Construction**

Field mount housing in cast light metal, painted

Center section: RAL 7012, dark gray

Cover: RAL 9002, light gray

**Forward / Reversion Flow Metering**

The flow direction is indicated in the display by a direction arrow and is signaled by an optocoupler for an external alarm.

**Display**

2x16-character LCD-Dot-Matrix display with LED background lighting. Both lines can be user configured for the indication of mass flowrate, volume flowrate, density or temperature. Flow totalization, 7-digit with overflow counter in mass or volume engineering units.

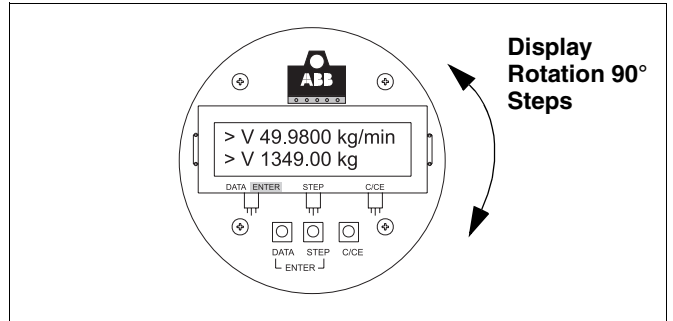

Fig. 14 Converter Keypad and Display

After the four mounting screws (1-4) have been loosened the converter can be repositioned in 4 orientations to assure optimum readability.



Fig. 15 Magnet Stick Operation

Magnetic stick operation makes it possible to configure the converter and enter data without opening the housing cover.

**Parameter Settings**

Data can be entered in a number of different languages using the 3 buttons on the converter.

The converter housing can be rotated in each direction by approx. 180°. There are four positions into which the display can be plugged to assure optimum readability. In the multiplex mode the flowrate in %, direct reading engineering units or as a bargraph, totalizer values forward or reverse, TAG-No. can be alternately displayed in addition to the display selections for the 1st and 2nd lines.

**Data Protection**

All data are stored in an NV-RAM for 10 years without supplementary power when the instrument is turned off or during a power outage. Additional process information safeguards are provided by a serial EEPROM in the converter by utilizing data up- or download procedures.

**Note:**

- The instrument satisfies the NAMUR-Recommendations "EMC-Guidelines for Manufacturers and Users of Electronic Instruments and Systems, Part 1", 5/93 and EMC-Guidelines 89/336/EWG (EN 50081-1, EN 50082-2), as well as the Low Voltage Guideline 73/23/EWG (EN 61010-1)

**Note:**

- The EMC- and personnel contact protection is voided when the housing cover is removed.

**Current Output1**

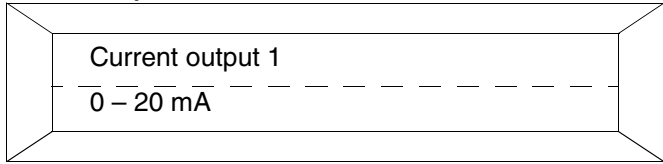

Function: Active  
 0/4 - 20 mA, selectable  
 Load:  $0 \Omega \leq R_L \leq 560 \Omega$  (Ex  $0 \Omega \leq R_L \leq 300 \Omega$ )  
 Terminals: 31/32  
 Uncertainty < 0.1 % of rate  
 For output of mass flowrate, volume flowrate, density and temperature.  
 Function user selectable in the software.

**Current Output 2**

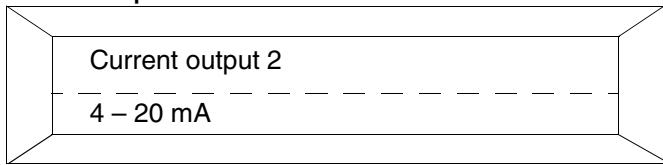

Function: Passive  
 Output current 4 - 22 mA  
 Load:  $0 \Omega \leq R_L \leq 600 \Omega$  (Ex  $0 \Omega \leq R_L \leq 300 \Omega$ )  
 Source voltage:  $12 V \leq U_s \leq 30 V$  (Ex  $14 V \leq U_s \leq 21 V$ )  
 Terminals: 33/34  
 Uncertainty < 0.1 % of rate  
 For output of mass flowrate, volume flowrate, density and temperature.  
 Function user selectable in the software.

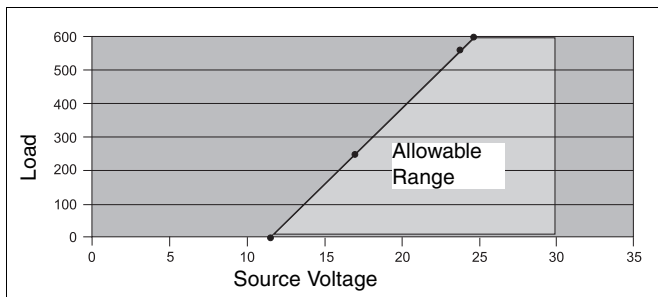
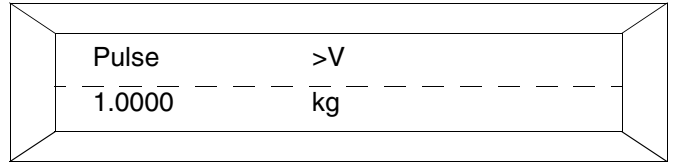
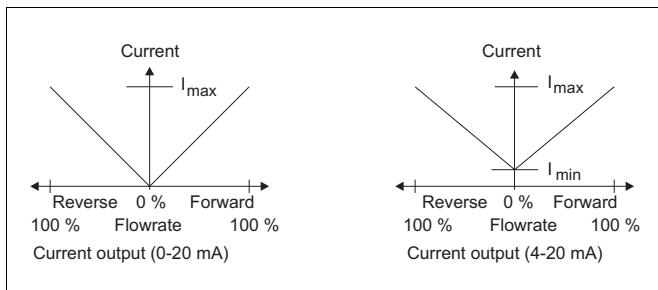

Fig. 16 Allowable Source Voltage as a Function of the Load Resistance at  $I_{max} = 22 \text{ mA}$  (non-EEEx)



**Scaled Pulse Output**

Scaled pulse output (max. 5 kHz) with a selectable pulse factor between 0.001 – 1000 pulses per selected engineering unit. The pulse width can be set from 0.1 to 2000 ms. The output is galvanically isolated from Current Output 1 and from Current Output 2.

Design	Passive	Active
Terminals	51, 52	51, 52
Operating voltage	$16 V \leq U_{CEH} < 30 V \text{ DC}$ $0 V \leq U_{CEL} < 2 V$	$16 V \leq U \leq 30 V \text{ DC}$ Load $\geq 150 \text{ Ohm}$
Operating current	$0 \text{ mA} \leq I_{CEH} < 0.2 \text{ mA}$ $2 \text{ mA} \leq I_{CEL} < 220 \text{ mA}$	$f_{max} = 5 \text{ kHz}$
	When using a mechanical counter pulse widths $\geq 30 \text{ ms}$ and $f_{max} \leq 3 \text{ Hz}$ are recommended	
Fmax	5 kHz	5 kHz
Pulse width	0.1 ms - 2000 ms	0.1 ms - 2000 ms

Ex-Design (Passive)	Ex "e" $U_T = 60 V$	Ex "ib" (NAMUR Contact)
Terminals	51,52	51,52
	$0 V \leq U_{CEL} \leq 2 V$ $2 \text{ mA} \leq I_{CEL} \leq 20 \text{ mA}$	$U_I = 15 V$ $I_I = 30 \text{ mA}$ $P_I = 115 \text{ mW}$ $C_I = 2.4 \text{ nF}$ $L_I = 0.17 \text{ mH}$
	$16 V \leq U_{CEH} \leq 30 V$	

**Contact Output**

The following functions can be assigned to the contact output in the software:

- System Monitor:** Normally open or normally closed contact
- Empty Pipe:** Normally open or normally closed contact
- Forward/Reverse Direction:** closed for forward direction
- Max-Min Alarm:** Normally open or normally closed contact

Terminals: 41, 42  
 "closed"  $0 V \leq U_{CEL} \leq 2 V$   
 $2 \text{ mA} \leq I_{CEL} \leq 220 \text{ mA}$

"open"  $16 V \leq U_{CEH} \leq 30 V$   
 $0 \text{ mA} \leq I_{CEH} \leq 0.2 \text{ mA}$

**Contact Input**

The following functions can be assigned to the contact input in the software:

- Ext. Zero Return.** When the meter tube empties the output signals can be turned off.
- Ext. Totalizer Rest.** The internal totalizers can be reset from an external contact.

Terminals: 81, 82  
 "On"  $16 V \leq U_{Ter} \leq 30 V$   
 "Off"  $0 V \leq U_{Ter} \leq 2 V$

Internal resistance:  $R_i = 2k\Omega$

**Interconnection Examples for Peripherals (Standard)**

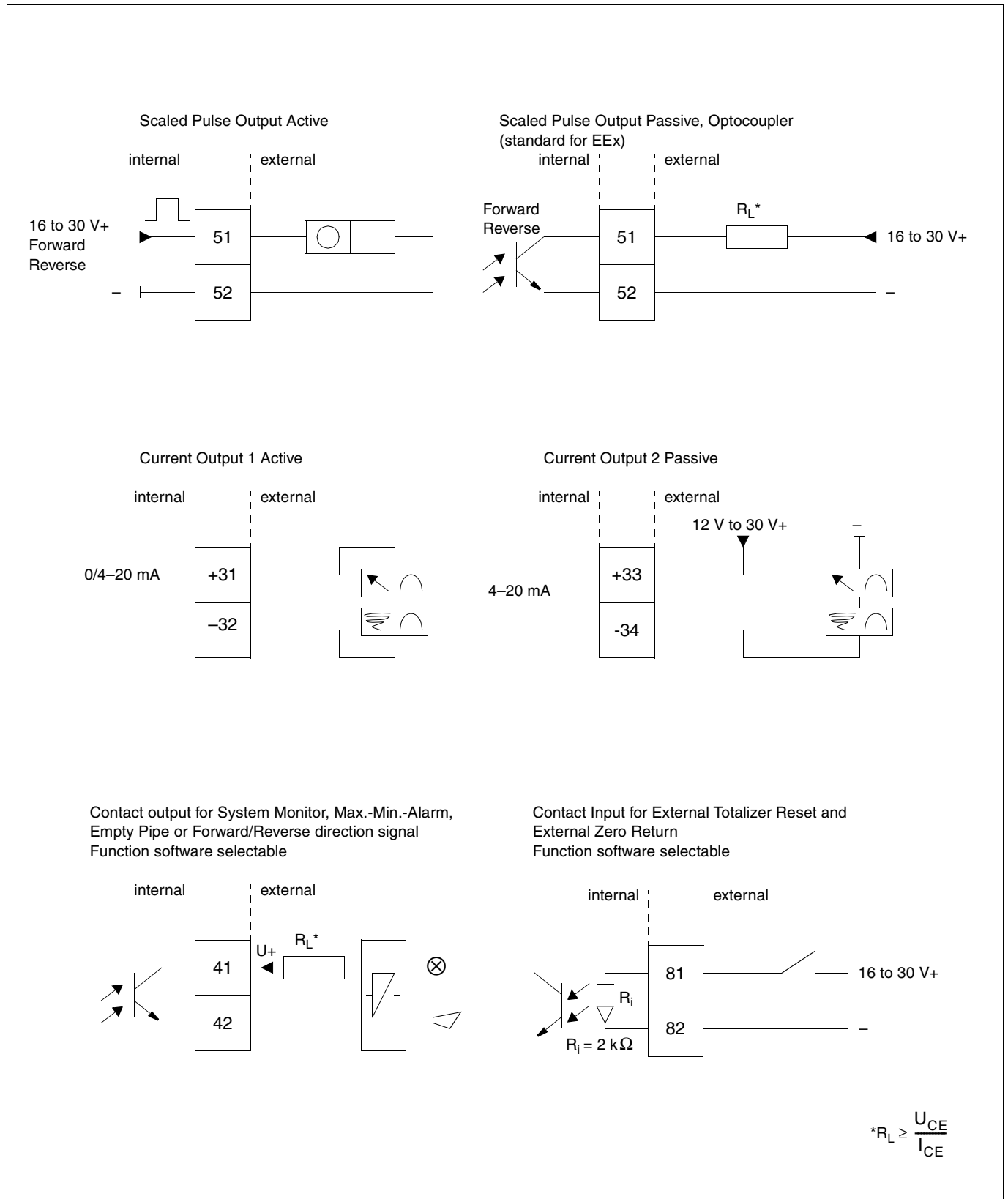

Fig. 17

## Specifications Converter, Standard

### HART<sup>®</sup>-Protocol

The HART<sup>®</sup>-Protocol provides for communication between a process control system, handheld terminal and a field instrument. If communication using the HART<sup>®</sup>-Protocol is required, the serial data link option is not available. The digital communication utilizes an ac signal superimposed on Current Output 1 which does not affect any other instruments connected to the output. This feature is only available with the 4–20 mA current output mode.

Terminals: 31/32

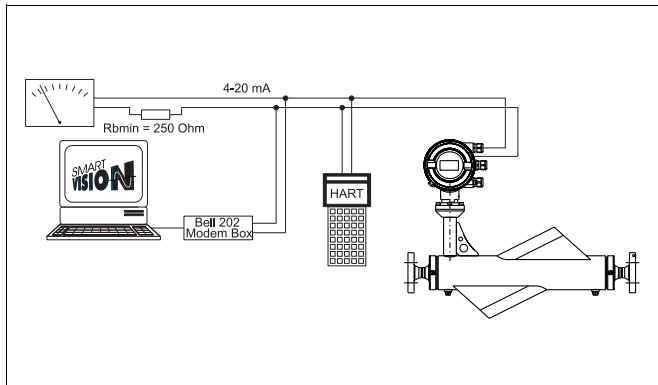

Fig. 18 Communication using HART-Protocol

### Transmission Mode

FSK-Modulation on the 4–20 mA current output per Bell 202 Standard.

### Baudrate

1200 Baud

### Format

Logic 1: 1200 Hz; Logic 0: 2200 Hz

### Cable

AWG 24 twisted

### Max. Cable Length

1500 m

### Max. Signal Amplitude

1.2 mApp

### Load. Current Output

Min. >250  $\Omega$  , max. <750  $\Omega$

Ex: Min. > 250  $\Omega$  , max. < 300  $\Omega$

**Interconnection Diagram: Flowmeter Primary / Converter**

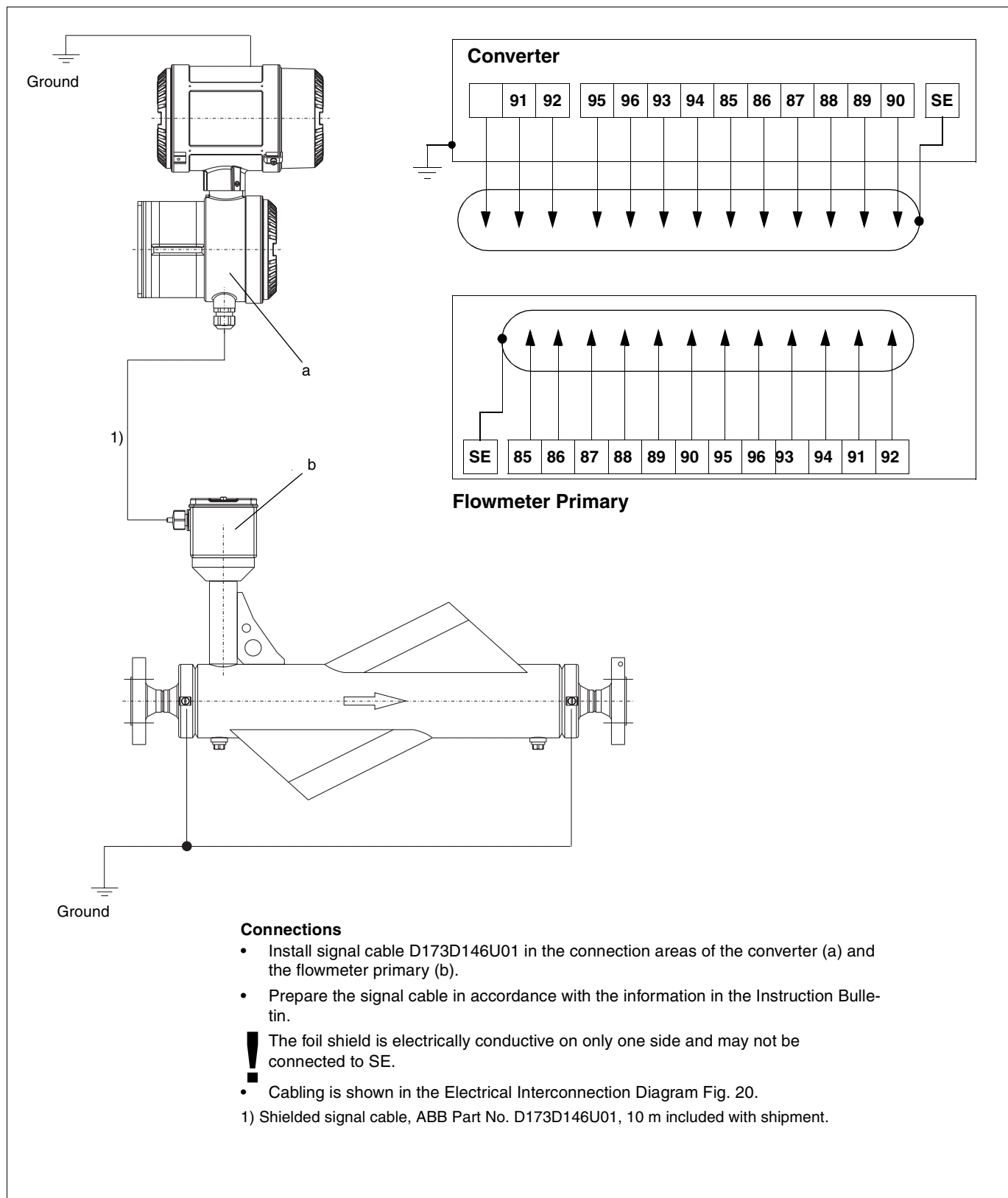

Fig. 19 Interconnection Diagram, Flowmeter Primary - Converter

**Interconnection Diagram: Input and Output Signals, Supply Power**

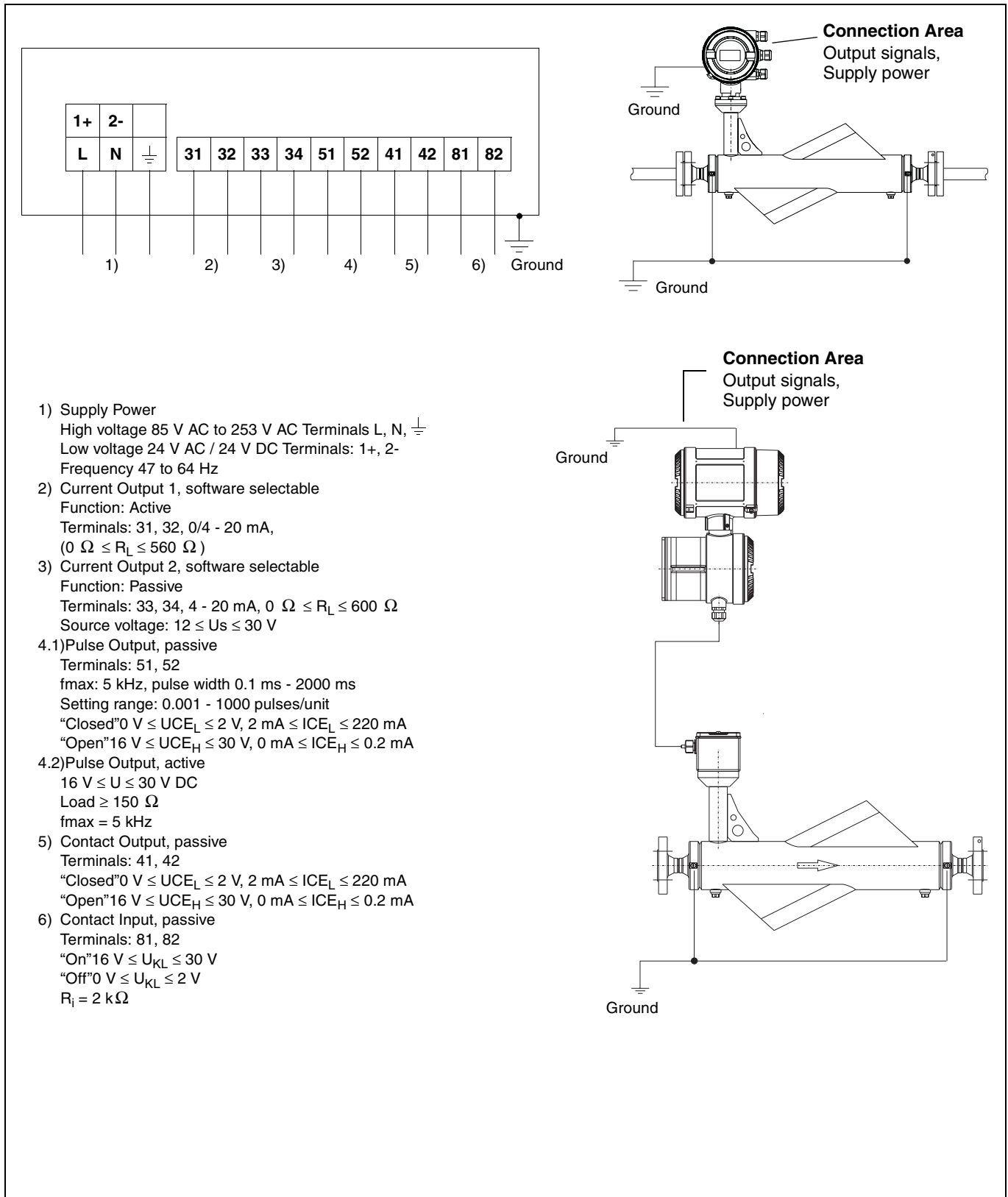

Fig. 20 Interconnection Diagram



**Interconnection Diagram: Input and Output Signals, Supply Power**

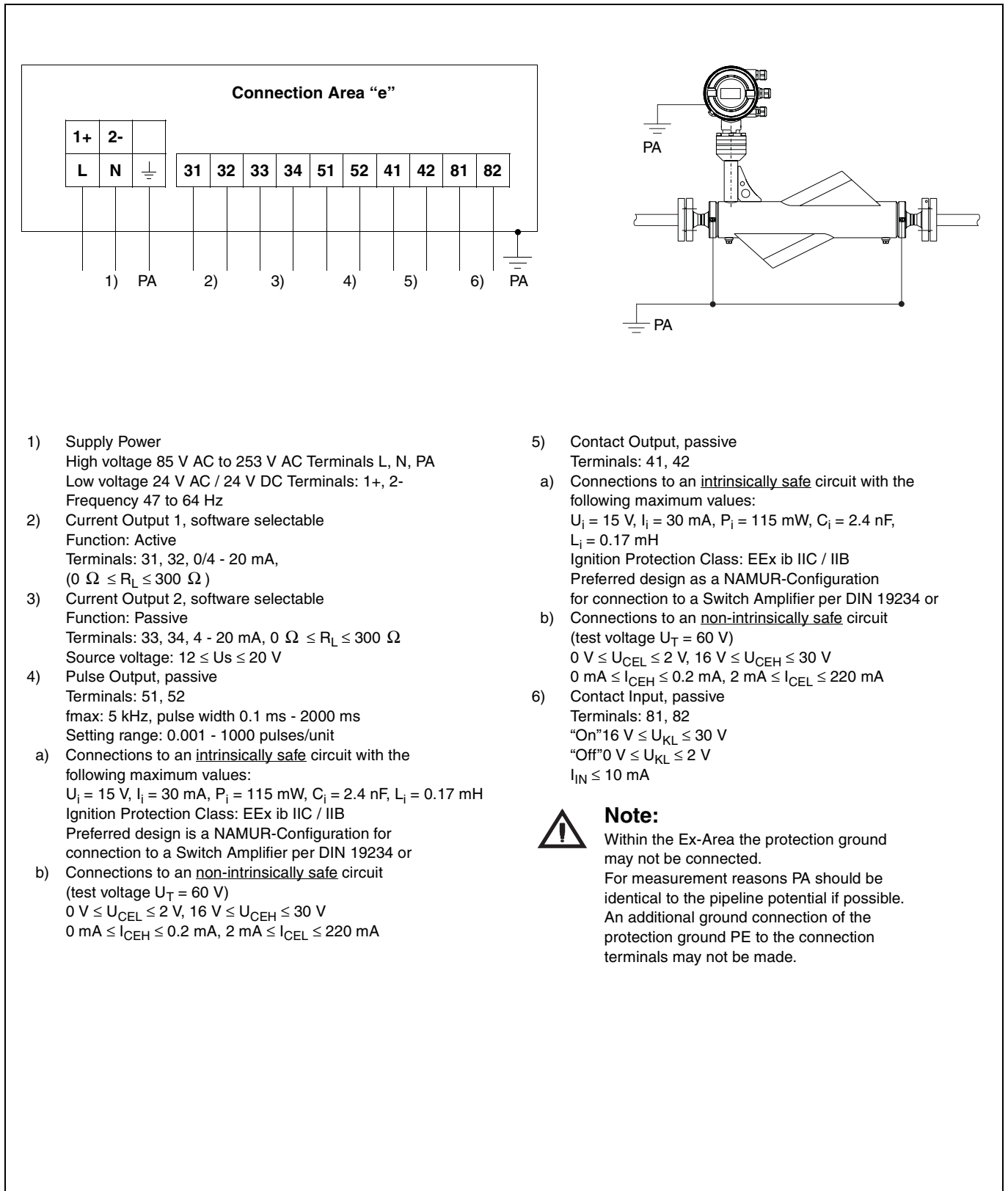
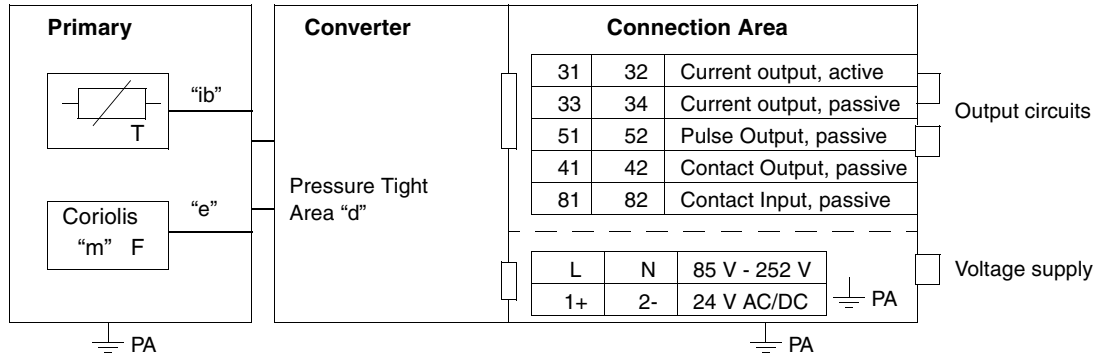

Fig. 21 Interconnection Diagram Ex-Design

**Information for Safe Operation in the Ex-Zone**



- Ignition Protection Type  
 II1/2G EEx emd [ib] IIC T6 for meter sizes  $\geq 2''$  [DN 50]  
 II 2G EEx emd [ib] IIC T6 for meter sizes  $\leq 1-1/2''$  [DN 40]  
 TÜV 99 ATEX 1443X
- Ambient temperature  $-20\text{ }^{\circ}\text{C}$  to  $+60\text{ }^{\circ}\text{C}$
- The Temperature Classes, which are a function of the ambient and fluid temperatures, are listed in the EC-Type Examination Certificate.
- The converter supply voltage specifications are listed on the Instrument Tag.
- The Ignition Protection Type of the converter outputs is determined by the external circuits connected to them and can be defined as "intrinsically safe" or "non-intrinsically safe". A combination of "intrinsically safe" and "non-intrinsically safe" is not permissible. The test voltage specification for the output circuits for both Ignition Protection Types is  $U_T = 60\text{ V}$ .
- The safety relevant specifications for intrinsically safe circuits are listed in the EU-Type Examination Certificate.
- Care should be exercised to assure that the supply voltage connections are properly covered. The connection area may be opened for the intrinsically safe option.
- It is recommended that the proper cable connectors, included with the shipment, be used for the output circuits for the appropriate safety classification: Intrinsically safe  $\rightarrow$  blue; non-intrinsically safe  $\rightarrow$  black.
- The flowmeter primary and the converter housing are to be connected to the Potential Equalization. For intrinsically safe current outputs, Potential Equalization must exist in the entire circuit.
- If the flowmeter primary is to be insulated, the insulation thickness surrounding the flowmeter primary should not exceed 100 mm. The converter housing may not be insulated.
- The corrosion resistance of the meter tube material to the fluid being metered must be evaluated.

**Insulation**

The pipeline and the flowmeter primary insulation should be installed as shown. The max. insulation thickness at the flowmeter primary is 100 mm.

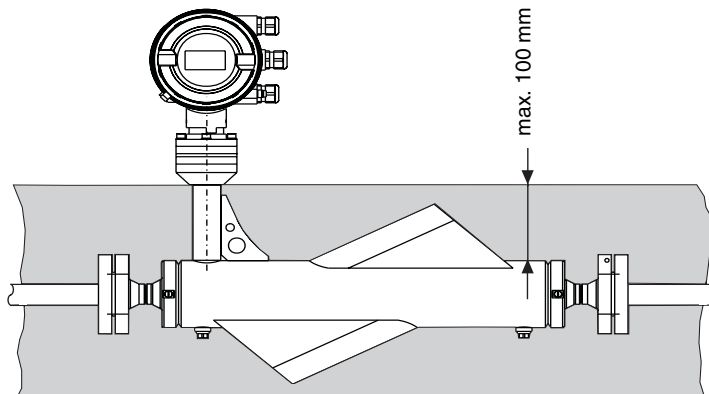

**Note:**  
 The temperature specifications in the Ex-Approval must be observed.

Fig. 22

<b>Safety Specifications for the In- and Outputs</b>
--

Output Circuit	Intrinsic Safety EEx ib IIC/IIB						Non-Intrinsic Safety $U_T = 60\text{ V}$
Current output Active Terminals 31/32	$U_O = 20\text{ V}$						$U_B = 30\text{ V}$ $I_B = 30\text{ mA}$
	$I_O$	$P_O$	EEx ib IIC		EEx ib IIB		
	[mA]	[mW]	$C_O$ [nF]	$L_O$ [mH]	$C_O$ [nF]	$L_O$ [mH]	
	100	500	217	3.8	1400	14.8	
	Curve: linear Internal capacitance $C_I = 2.4\text{ nF}$ , internal inductance $L_I = 0.17\text{ mH}$ Only for connection to a passive, intrinsically safe circuit or intrinsically safe circuits with the following maximum values: $U_I = 60\text{ V}$ Terminal 32 is to be connected to PA.						
Current output Passive Terminals 33/34	$U_I = 30\text{ V}$ $I_I = 100\text{ mA}$		$C_I = 2.4\text{ nF}$ $L_I = 0.17\text{ mH}$				$U_B = 30\text{ V}$ $I_B = 30\text{ mA}$
Terminal 34 is to be connected to PA.							
Contact Output Terminals 41/42 Pulse Output Terminals 51/52	$U_I = 15\text{ V}$ $I_I = 30\text{ mA}$ $P_I = 115\text{ mW}$		$C_I = 2.4\text{ nF}$ $L_I = 0.17\text{ mH}$				$U_B = 30\text{ V}$ $I_B = 220\text{ mA}$
Contact Input Passive Terminals 81/82	$U_I = 30\text{ V}$ $I_I = 250\text{ mA}$ $P_I = 1.1\text{ W}$		$C_I = 2.4\text{ nF}$ $L_I = 0.17\text{ mH}$				$U_B = 30\text{ V}$ $I_B = 10\text{ mA}$

**Special Requirements:**

The output circuits are designed to be connected to either intrinsically safe or non-intrinsically safe circuits. A combination of intrinsically safe and non-intrinsically safe circuits is not permissible. For intrinsically safe current outputs Potential Equalization must exist in the entire circuit.

The test voltage for non-intrinsically safe circuits is  $U_T = 60\text{ V}$ .

The contact output and pulse output can be configured internally (Terminals 41/42, 51/52) as NAMUR-Contacts for connection to a NAMUR-Amplifier.

The meters are shipped with the black cable connectors installed. If the signal outputs are connected to intrinsically safe circuits, it is recommended that the light blue cable connectors included with the shipment are to be installed for the corresponding cable entries.

**Dimensions Compact Design: Flanged Construction, „C“ to „F“, DIN/ANSI**

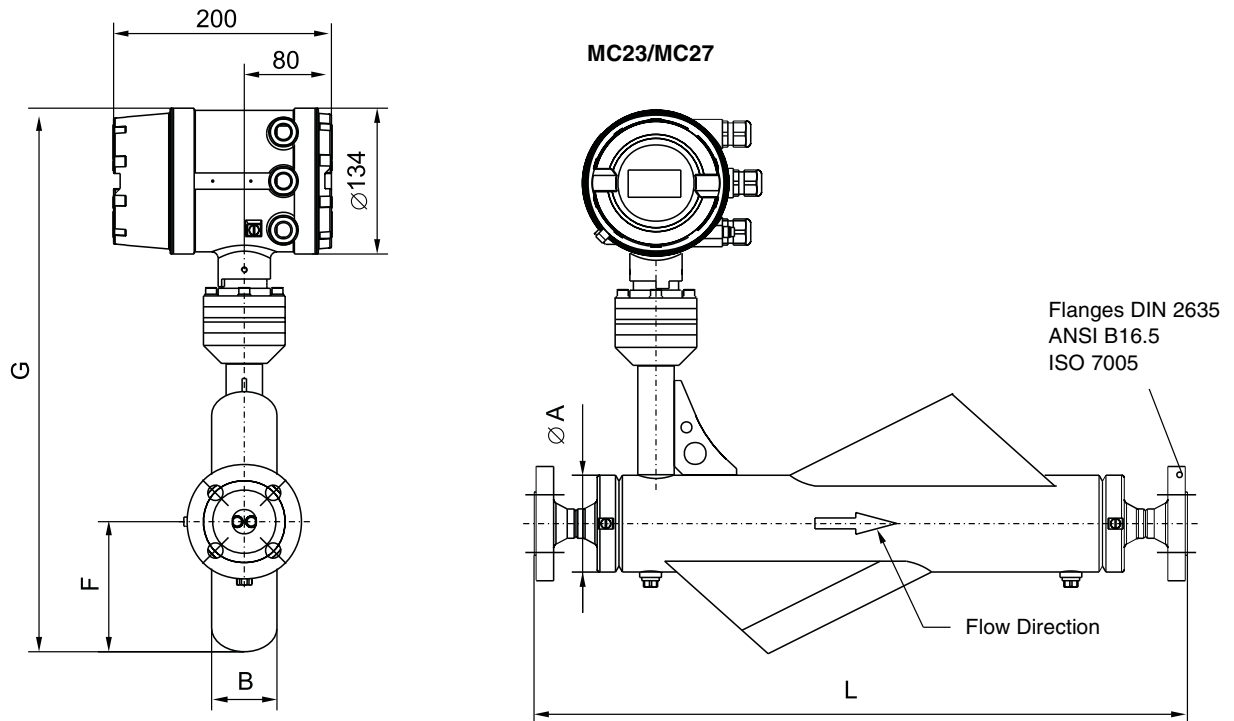

Meter Size Inch DN	A	F	B	G (MC23)	G (MC27)	Process Conn's		L			Weight ca. kg
						Size Inch DN	DN	DIN 2635 (PN 40)	ANSI CL 150 ISO PN 20	ANSI CL 300 ISO PN 50	
"B" 1/4 6	60	83	45	425	449	10	493				10
						1/2 15	578	593	603		
"C" 3/8 10	60	83	45	425	449	10	493				10
						1/2 15	578	593	603		
"D" 1/2 15	76	93	45	443	467	10	653				12
						1/2 15	578	593	603	12	
						3/4 20	683	703	713		
"E" 3/4 20	89	114	60	470	494	1/2 15	693	708	718	16	
						3/4 20	598	618	628		
						1 25	698	728	738		
"F" 1 25	89	114	60	470	494	3/4 20	758	778	788	17	
						1 25	658	688	698		
						1-1/2 40	808	838	893		

All dim's in mm  ISO Projection Method E

Fig. 23 Dimensions, Compact Design, Flanged Construction, "C" to "F", DIN/ANSI

Dimensions, Remote Design, Flanged Construction, "C" to "F", DIN/ANSI

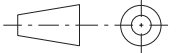
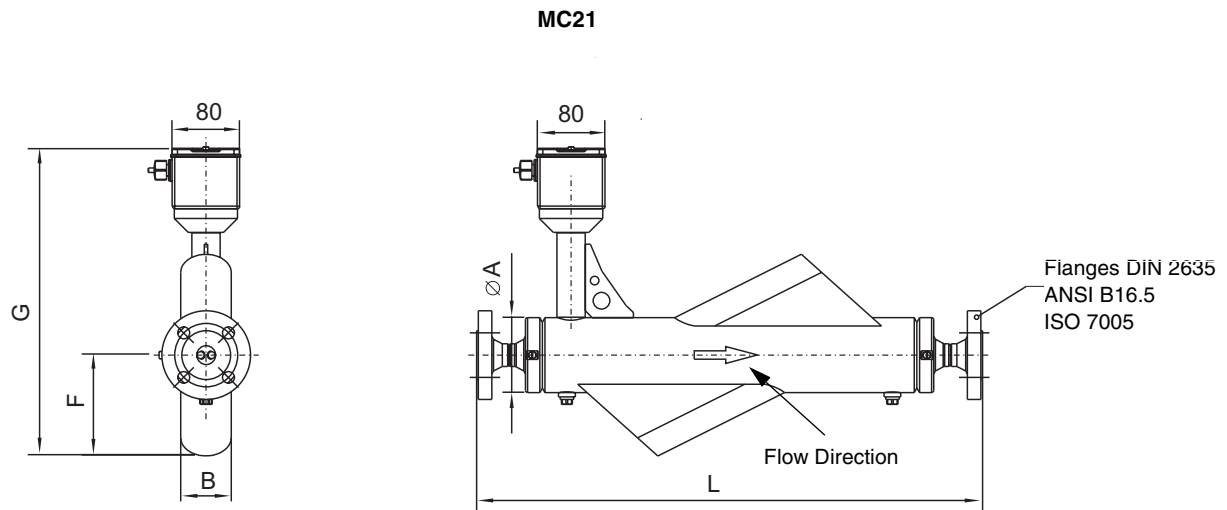

Meter Size Inch DN	Process Conn's Inch DN		L			G	F	B	Ø A	Weight [kg]
	DIN 2635 PN 40	ANSI CL 150	ANSI CL 300							
"C"	3/8 10	1/2 10	493			313	83	45	60	9
		1/2 15	578	593	603					
"D"	1/2 15	1/2 10	653			331	93	45	76	11
		1/2 15	578	593	603					11
		3/4 20	683	703	713					13
"E"	3/4 20	1/2 15	693	708	718	358	114	60	89	15
		3/4 20	598	618	628					15
		1 25	698	728	738					16
		1 25	758	778	788					16
"F"	1 25	1 25	658	688	698	358	114	60	89	16
		1 25	658	688	698					16
		1-1/4 40	808	838	893					19

All dim's in mm

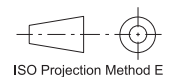
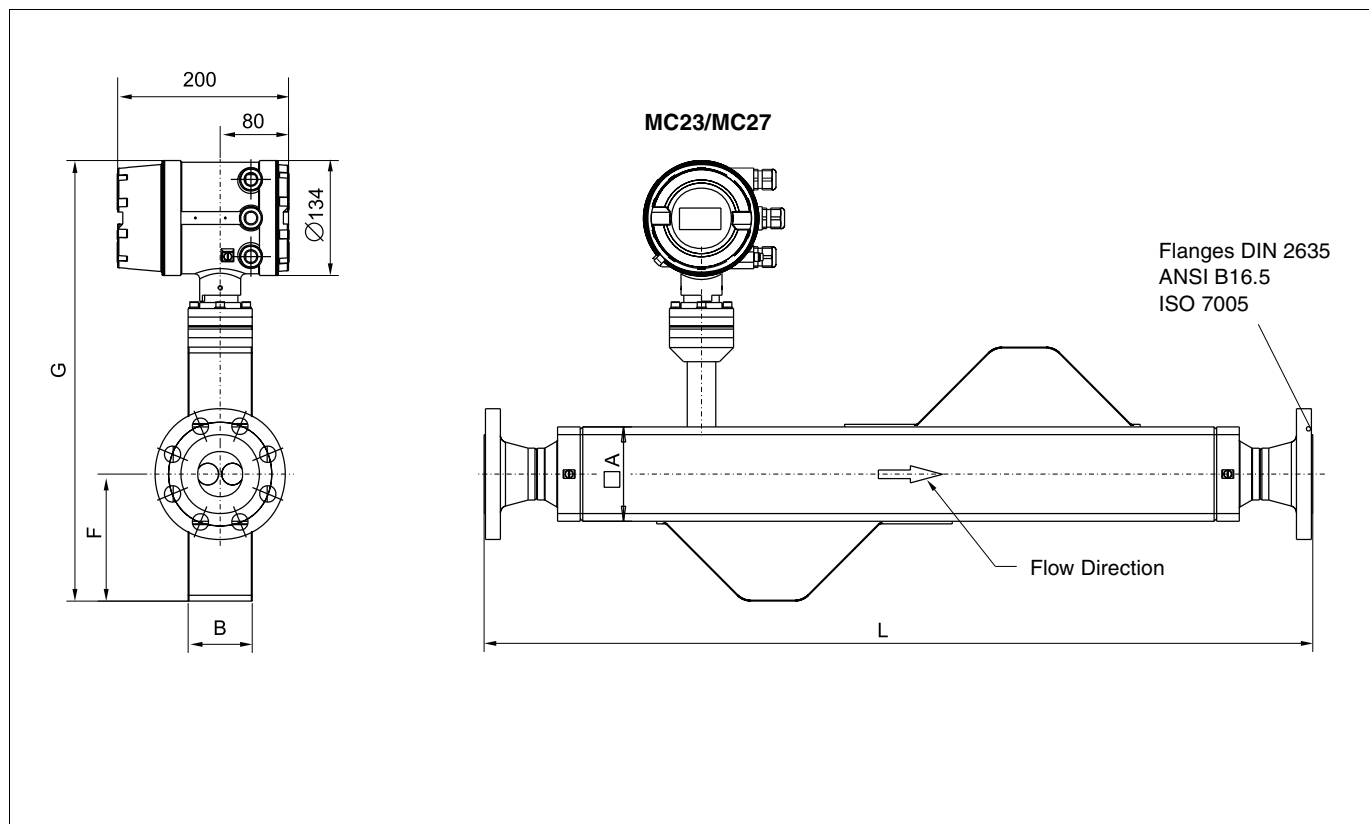

Fig. 24 Dimensions, Remote Design, Flanged Construction, "C" to "F", DIN/ANSI

**Dimensions, Dimensions, Compact Design, Flanged Construction, „G“ to „L“, DIN/ANSI**



Meter Size Inch DN	A	F	B	G (MC23)	G (MC27)	Process Conn's		L				Weight ca. kg
						Size Inch DN	DIN 2633 (PN 40)	DIN 2635 (PN 40)	ANSI CL 150 ISO PN 20	ANSI CL 300 ISO PN 50		
"G" 1-1/2 40	90	129	64	486	511	1 25		879	910	922	21	
						1-1/2 40		780	810	825	23	
						2 50		940	970	980	24	
"H" 2 50	110	149	80	515	540	1-1/2 40		1045	1075	1090	33	
						2 50		940	970	980	35	
						2-1/2 65		1100	1135	1145	39	
"I" 2-1/2 65	130	164	97	541	566	2 50		1220	1250	1260	44	
						2-1/2 65		1100	1135	1145	48	
						2-1/2 65	Mat'l 2.4610	1100	1220	1230	49	
						3 80		1220	1240	1260	51	
"J" 3 80	140	186	108	568	593	2-1/2 65		1330	1365	1375	57	
						3 80		1220	1240	1260	59	
						4 100	1450	1480	1500	1520	70	
"K" 4 100	170	215	131	612	637	3 80		1640	1660	1680	85	
						4 100	1450	1480	1500	1520	92	
"L" 6 150	250	285	190	722	747	6 150	2000	2040	2070	2090	191	

All dim's in mm

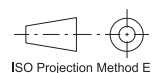
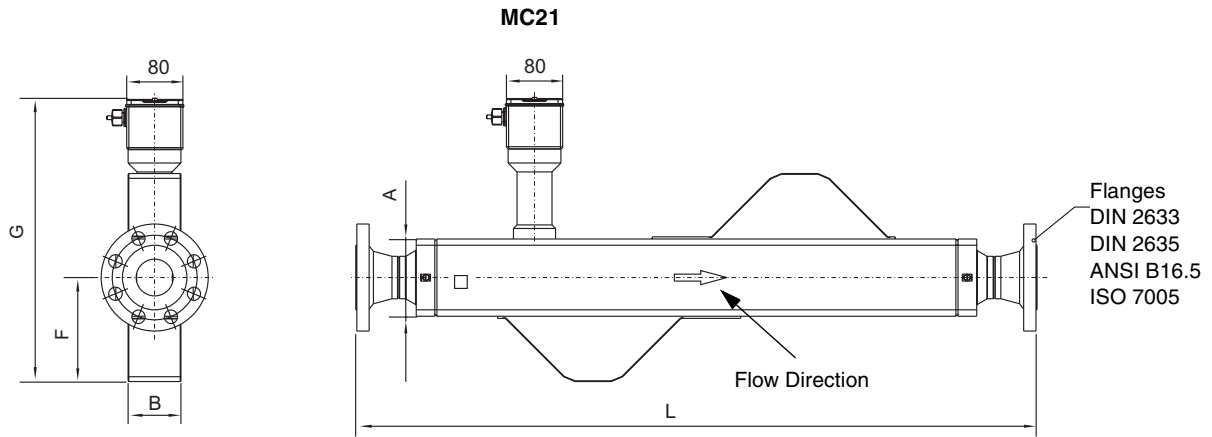

Fig. 25 Dimensions, Compact Design, Flanged Construction, „G“ to „L“, DIN/ANSI

**Dimensions, Remote Design, Flanged Construction, "G" to "L", DIN/ANSI**



Meter Size Inch DN	Process Connection Size		DIN 2633 PN 16	L		ANSI CL 150	ANSI CL 300	G	F	B	A	Weight kg]
	Inch	DN		DIN 2635 PN 40	ANSI CL 150							
„G“ 1-1/2 40	1	25		879	910	922	374	129	64	90		20
	1-1/2	40		780	810	825						22
	2	50		940	970	980						23
„H“ 2 50	1-1/2	40		1045	1075	1090	403	148	80	110		32
	2	50		940	970	980						34
	2-1/2	65		1100	1135	1145						38
„I“ 2-1/2 65	2	50		1220	1250	1260	429	164	97	130		43
	2-1/2	65		1100	1135	1145						47
	2-1/2	65		1100	1220	1230						48
	(Mat'l: 2.4610)	65		1220	1240	1260						50
	3	80		1330	1365	1375						56
„J“ 3 80	2-1/2	65		1220	1240	1260	456	186	108	140		58
	3	80	1450	1480	1500	1520						69
	4	100		1640	1660	1680						84
„K“ 4 100	3	80	1450	1480	1500	1520	500	215	131	170		91
	4	100		1990	2040	2070						2090
„L“ 6 150	6	150	1990	2040	2070	2090	613	285	190	250		190

All dim's in mm

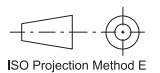
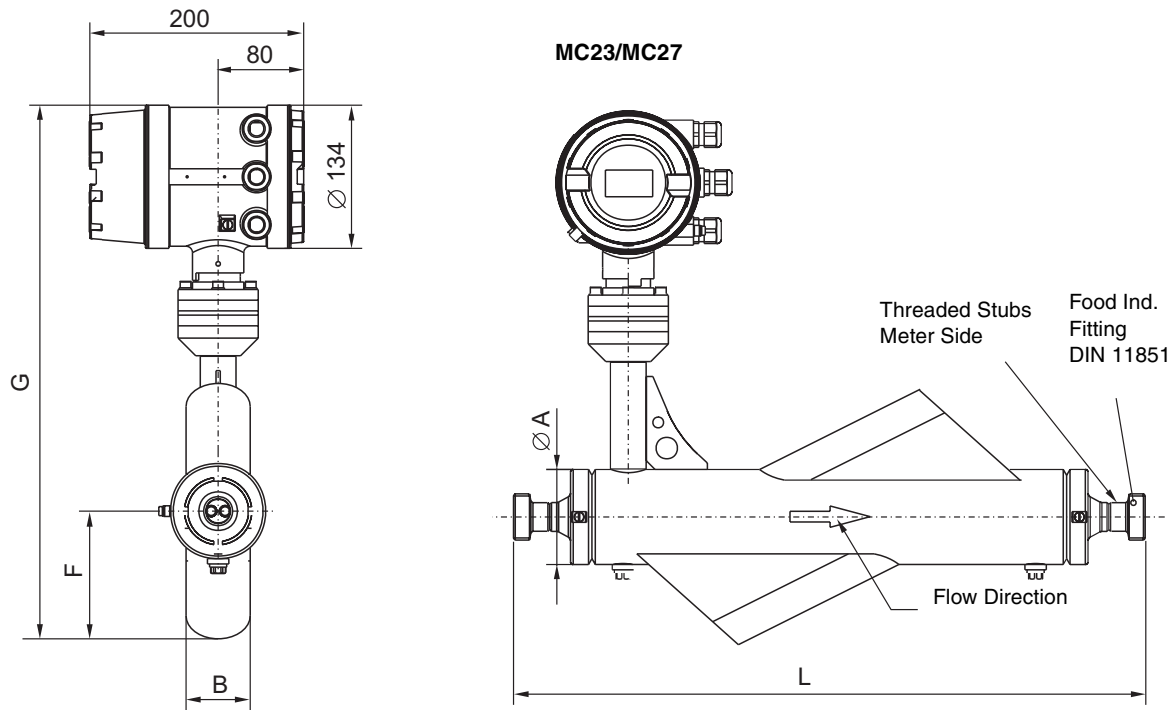

Fig. 26 Dimensions, Remote Design, Flanged Construction, "G" to "L", DIN/ANSI

**Dimensions, Compact Design, Food Industry Fittings, „B“ to „F“, DIN 11851**



DN (Size)	A	F	B	G (MC23)	G (MC27)	Process Conn's		Weight ca. kg
						DN	L DIN 11851	
10 ("C")	60	83	45	425	449	10	475	8
						15	555	
15 ("D")	76	93	45	443	467	10	635	10
						15	555	
						20	662	
20 ("E")	89	114	60	470	494	15	670	14
						20	580	
						25	680	
25 ("F")	89	114	60	470	494	20	740	15
						25	640	
						40	786	

All dim's in mm

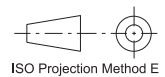
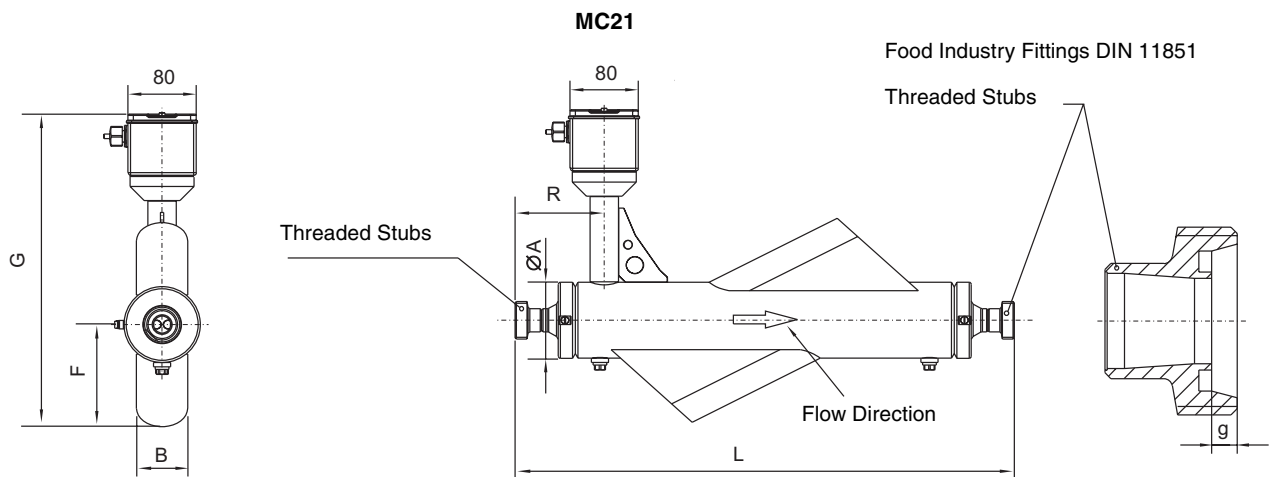

Fig. 27 Dimensions, Compact Design, Food Industry Fittings, „B“ to „F“, DIN 11851

**Dimensions, Remote Design, Food Industry Fittings, "C" to "F", DIN 11851**



Meter Size	Process Connections	L	g	G	F	B	Ø A	R	Weight [kg]
„C“ (10)	DN 10 Rd 28 x 1/8	475	4	313	87	45	60	94	7
	DN 15 / 1/2" Rd 34 x 1/8	555	4					132	
„D“ (15)	DN 10 Rd 28 x 1/8	635	4	331	93	45	76	138	9
	DN 15 / 1/2" Rd 34 x 1/8	555	4					98	
	DN 20 / 3/4" Rd 44 x 1/6	662	6					148	
„E“ (20)	DN 15 / 1/2" Rd 34 x 1/8	670	4	371	127	66	89	152	13
	DN 20 / 3/4" Rd 44 x 1/6	580	6					102	
	DN 25 / 1" Rd 52 x 1/6	680	7					152	
„F“ (25)	DN 20 / 3/4" Rd 44 x 1/6	740	6	371	127	66	89	162	14
	DN 25 / 1" Rd 52 x 1/6	640	7					112	
	DN 40 / 1 1/2" Rd 65 x 1/6	786	7					185	

All dim's in mm

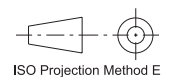

Fig. 28 Dimensions, Remote Design, Food Industry Fittings, "C" to "F", DIN 11851

**Dimensions, Compact Design, Food Industry Fittings, "G" to "K", DIN 11851**

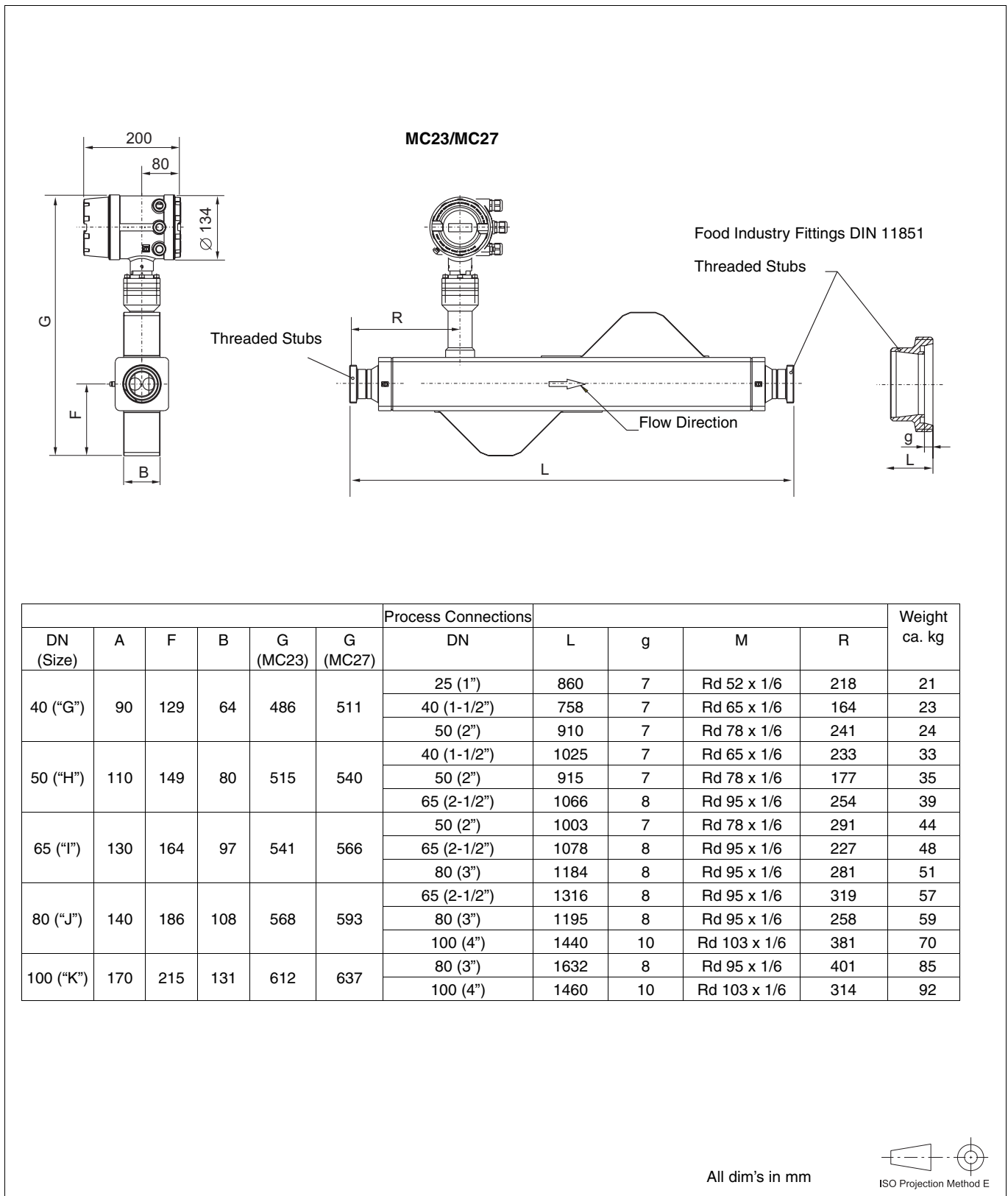
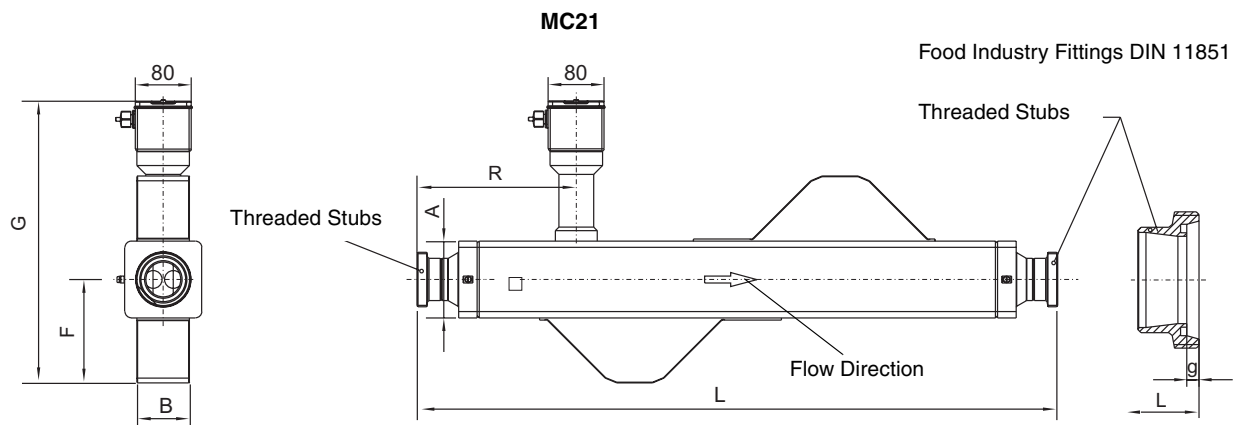

Fig. 29 Dimensions, Compact Design, Food Industry Fittings, "G" to "K", DIN 11851

**Dimensions, Remote Design, Food Industry Fittings, "G" to "K", DIN 11851**



Meter Size	Process Connections	L	g	G	F	B	A	R	Weight [kg]
„G“ (40)	DN 25 / (1") Rd 52 x 1/6	860	7					218	16
	DN 40 / (1-1/2") Rd 65 x 1/6	758	7	374	129	64	90	164	18
	DN 50 / (2") Rd 78 x 1/6	910	7					241	19
„H“ (50)	DN 40 / (1-1/2") Rd 65 x 1/6	1025	7					233	28
	DN 50 / (2") Rd 78 x 1/6	915	7	403	148	80	110	177	30
	DN 65 / (2-1/2") Rd 95 x 1/6	1066	8					254	34
„I“ (65)	DN 50 / (2") Rd 78 x 1/6	1203	7					291	40
	DN 65 / (2-1/2") Rd 95 x 1/6	1078	8	429	164	97	130	227	44
	DN 80 / (3") Rd 95 x 1/6	1184	8					281	47
„J“ (80)	DN 65 / (2-1/2") Rd 95 x 1/6	1316	8					319	54
	DN 80 / (3") Rd 95 x 1/6	1195	8	456	186	108	140	258	56
	DN 100 / (4") Rd 103 x 1/4	1440	10					381	60
„K“ (100)	DN 80 / (3") Rd 95 x 1/6	1632	8	500	215	131	170	401	82
	DN 100 / (4") Rd 103 x 1/4	1460	10					314	86

All dim's in mm

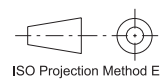
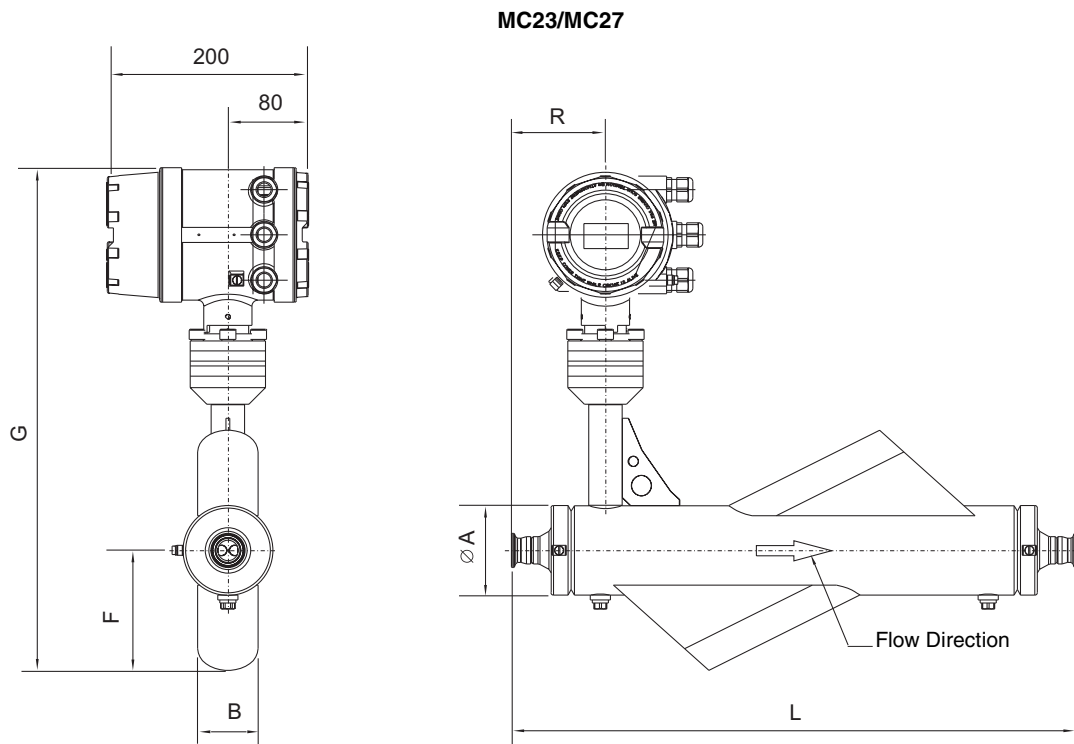

Fig. 30 Dimensions, Remote Design, Food Industry Fittings, "G" to "K", DIN 11851

**Dimensions, Compact Design, Tri-Clamp DIN 32676, "C" to "F"**



DN (Size)	A	F	B	G (MC23)	G (MC27)	Process Connections			Weight ca. kg
						DN	L	R	
6 ("B")	60	87	45	429	453	10	465	88	8
						15	540	125	
10 ("C")	60	87	45	429	453	10	465	88	8
						15	540	125	
15 ("D")	76	97	45	447	471	10	625	133	10
						15	540	91	
						20	645	143	
20 ("E")	89	127	66	483	507	15	655	140	14
						20	560	92	
						25	660	142	
25 ("F")	89	127	66	483	507	20	720	152	15
						25	620	102	
						40	775	180	

All dim's in mm

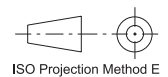
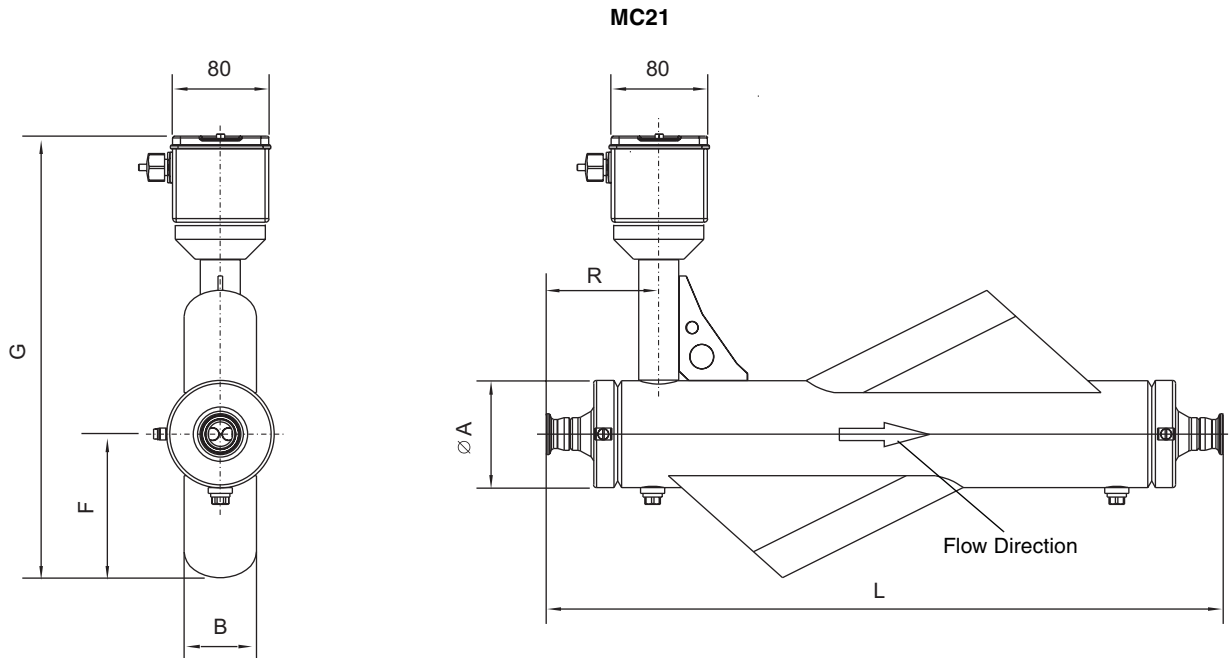

Fig. 31 Dimensions, Compact Design, Tri-Clamp DIN 32676, "C" to "F"

Dimensions, Remote Design, Tri-Clamp DIN 32676, "C" to "F"



Meter Size	Process Connections	L	G	F	B	Ø A	R	Weight [kg]
„C“ (10)	DN 10	465	317	87	45	60	88	6
	DN 15 DIN 32676	540						
„D“ (15)	DN 10	625	335	97	45	76	133	9
	DN 15	540						
	DN 20 DIN 32676	645						
„E“ (20)	DN 15	655	371	127	66	89	140	12
	DN 20	560						
	DN 25 DIN 32676	660						
„F“ (25)	DN 20	720	371	127	66	89	152	13
	DN 25	620						
	DN 40	775						

All dim's in mm

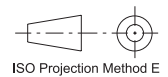
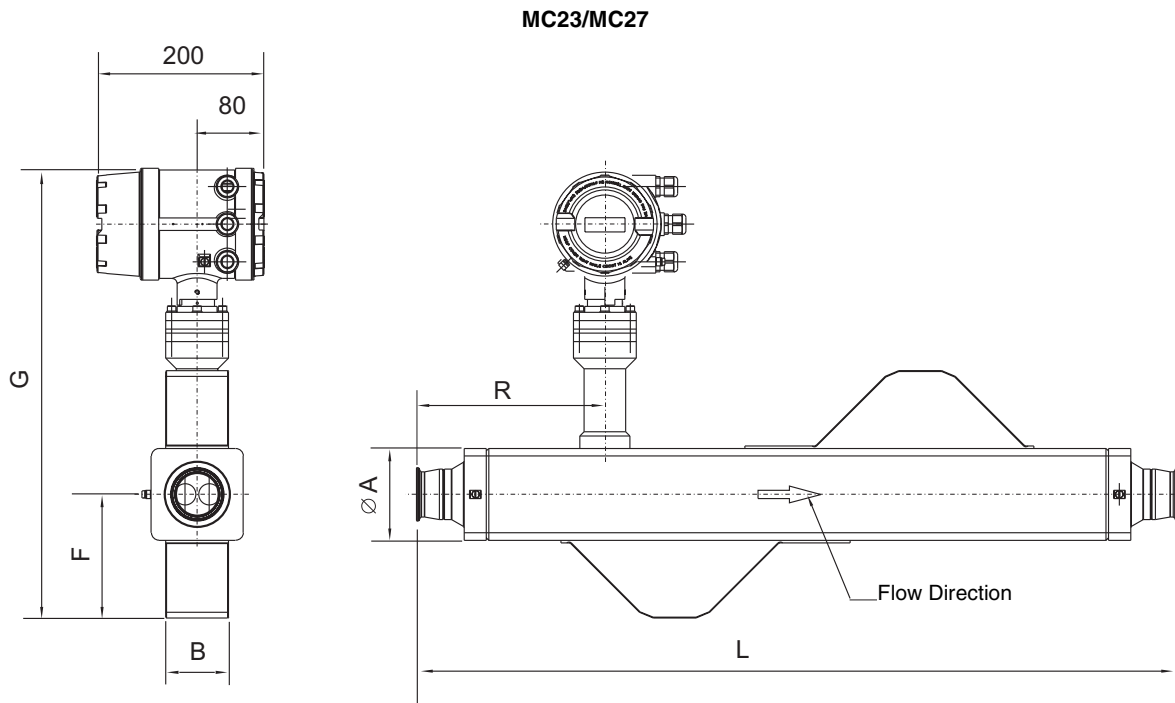

Fig. 32 Dimensions, Remote Design, Tri-Clamp DIN 32676, "C" to "F"

**Dimensions, Compact Design, Tri-Clamp DIN 32676, "G" to "K"**



DN (Size)	A	F	B	G (MC23)	G (MC27)	Process Connections			Weight ca. kg
						DN	L	R	
40 ("G")	90	129	64	486	511	25 (1")	840	242	17
						40 (1-1/2")	745	195	17
						50 (2")	910	278	18
50 ("H")	110	148	80	515	540	40 (1-1/2")	1010	275	27
						50 (2")	910	225	26
						65 (2-1/2")	1070	305	27
65 ("I")	130	164	97	541	566	50 (2")	1190	335	36
						65 (2-1/2")	1070	275	37
						80 (3")	1176	328	38
80 ("J")	140	186	108	568	593	65 (2-1/2")	1340	378	45
						80 (3")	1176	296	44
						100 (4")	1445	430	46
100 ("K")	170	215	131	612	637	80 (3")	1596	440	71
						100 (4")	1445	365	69

All dim's in mm

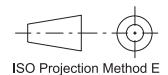
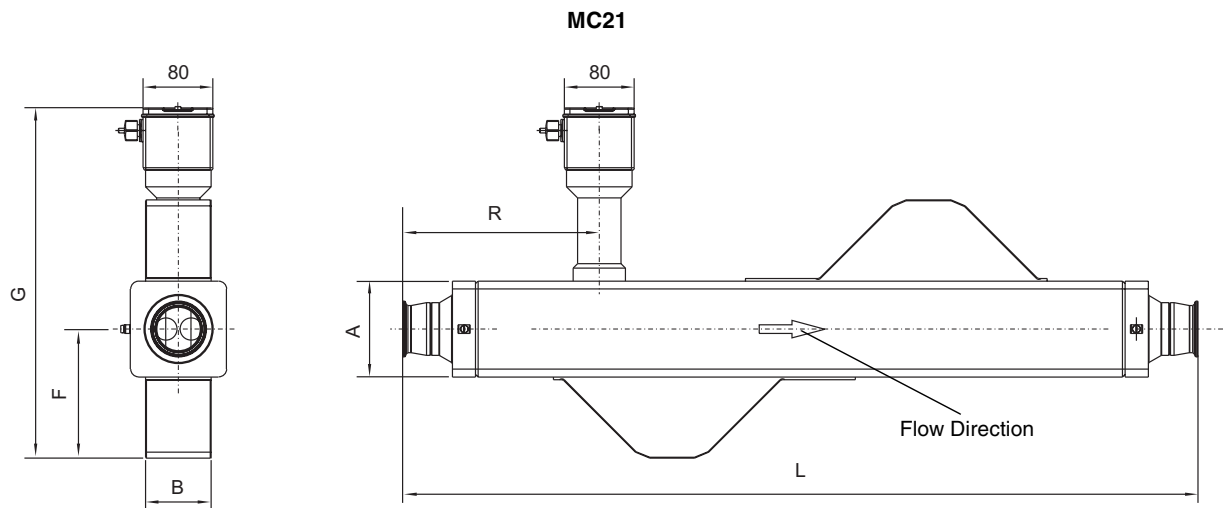

Fig. 33 Dimensions, Compact Design, Tri-Clamp DIN 32676, "G" to "K"

**Dimensions, Remote Design, Tri-Clamp DIN 32676, "G" to "K"**



Meter Size	Process Connections	L ± 3	G	F	B	A	R	Weight [kg]
„G“ (40)	DN 25 (1")	840					242	17
	DN 40 (1-1/2")	745	374	129	64	90	195	17
	DN 50 (2")	910					278	18
„H“ (50)	DN 40 (1-1/2")	1010					275	27
	DN 50 (2")	910	403	148	80	110	225	26
	DN 65 (2-1/2")	1070					305	27
„I“ (65)	DN 50 (2")	1190					335	36
	DN 65 (2-1/2")	1070	429	164	97	130	275	37
	DN 80 (3")	1176					328	38
„J“ (80)	DN 65 (2-1/2")	1340					378	45
	DN 80 (3")	1176	456	186	108	140	296	44
	DN 100 (4")	1445					430	46
„K“ (100)	DN 80 (3")	1596					440	71
	DN 100 (4")	1445	500	215	131	170	365	69

All dim's in mm

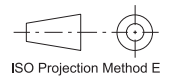

Fig. 34 Dimensions, Remote Design, Tri-Clamp DIN 32676, "G" to "K"

Dimensions, Converter

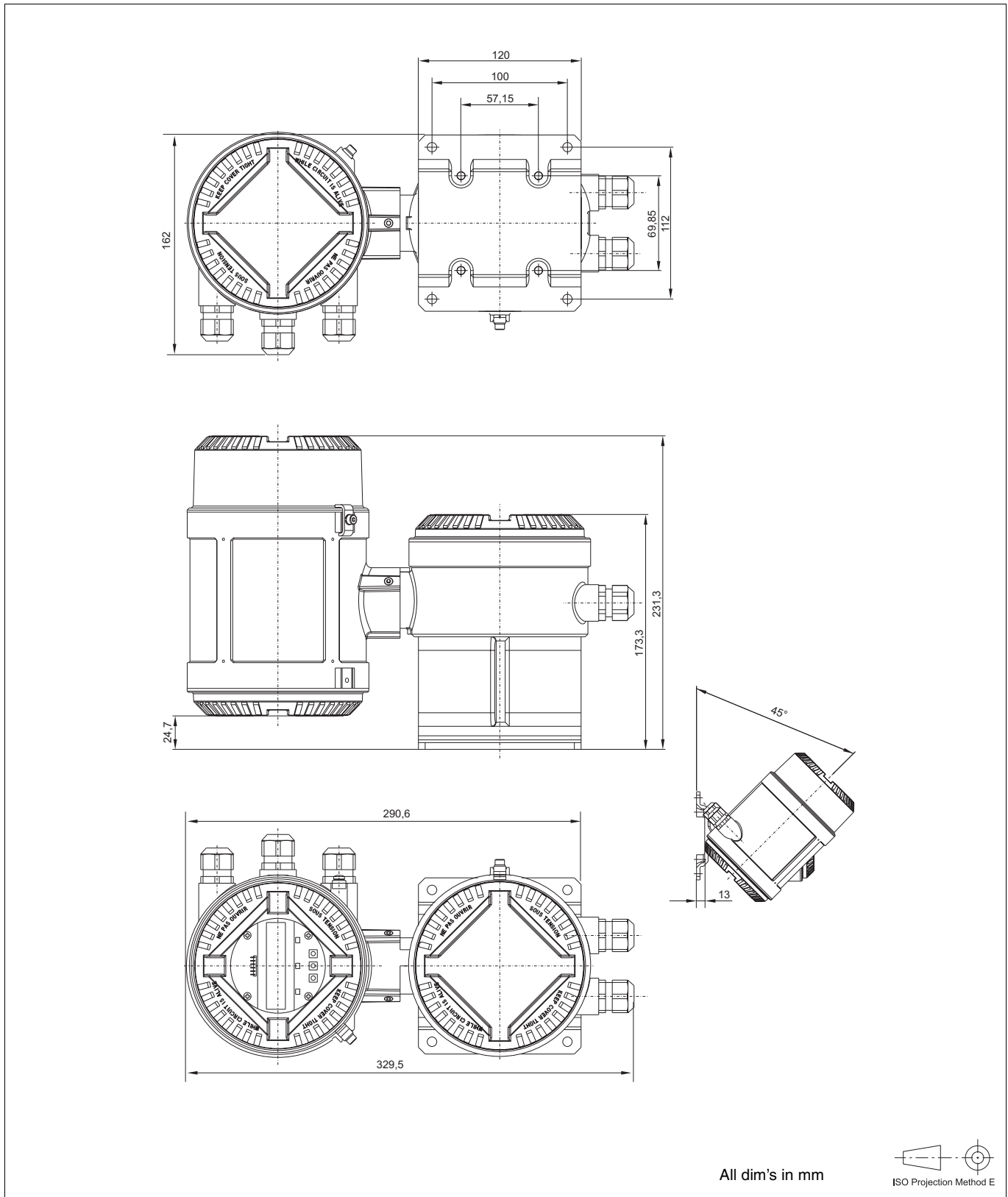

Fig. 35 Dimensions, Converter

**Ordering Information; MC21: Remote Design / MC23, MC27: Compact Design**

Ordering Number		MC2																		
<b>Design (Flowmeter Primary/Converter)</b>																				
Remote design, with converter ME21		1																		
Compact design		3																		
Ex, compact design		7																		
<b>Certifications / Connectors</b>																				
None / Cable connector M20 x 1.5			A																	
CENELEC-Approval/ Cable connector M20 x 1.5			B																	
<b>Material Certificates</b>																				
None																				
3.1B per EN 10204																				
<b>Meter Tube Material</b>																				
Stn. stl. 316Ti/1.4571																				
Hastelloy C4 2.4610																				
<b>Flow Range [kg/min] Size Inch [DN]</b>																				
<b>Nom. Flow Range</b>	<b>Max. Flow Range</b>	<b>nominal</b>																		
0 - 11	0 - 13	"B" 1/4	6	1)	in preparation															
0 - 18	0 - 25	"C" 3/8	10																	
0 - 45	0 - 60	"D" 1/2	15																	
0 - 75	0 - 100	"E" 3/4	20																	
0 - 125	0 - 160	"F" 1	25																	
0 - 365	0 - 475	"G" 1-1/2	40																	
0 - 710	0 - 920	"H" 2	50																	
0 - 1450	0 - 1890	"I" 2-1/2	65																	
0 - 1890	0 - 2460	"J" 3	80																	
0 - 3200	0 - 4160	"K" 4	100																	
0 - 8500	0 - 11000	"L" 6	150																	
<b>Process Connection Size (for available combinations, see Dimensions)</b>																				
1/2"	DN 10																			
1/2"	DN 15																			
3/4"	DN 20																			
1"	DN 25																			
1-1/2"	DN 40																			
2"	DN 65																			
2-1/2"	DN 65																			
3"	DN 80																			
4"	DN 100																			
6"	DN 150																			
<b>Process Connection Types (for available combinations, see Dimensions)</b>																				
Flanges DIN PN 16																				
Flanges DIN PN 40																				
Flanges DIN PN 64 <sup>1)</sup> in preparation																				
Flanges DIN PN 100 <sup>1)</sup> in preparation																				
Flanges ANSI CL 150																				
Flanges ANSI CL 300																				
Flanges ANSI CL 600 <sup>1)</sup> in preparation																				
Tri-Clamp																				
Food Industry Fitting DIN 11851																				
<b>Housing (Flowmeter Primary)</b>																				
Standard																				
Pressure tight <sup>1)</sup> in preparation																				
<b>Heating/Cooling</b>																				
None																				
<b>Calibration</b>																				
Flowrate forward ± 0.40 % of rate /density (± 5 g/l)																				
Flowrate forward ± 0.25 % of rate /density (± 5 g/l)																				
Flowrate forward ± 0.15 % of rate /density (± 5 g/l)																				
Flowrate forward ± 0.40 % of rate /density (± 1 g/l)																				
Flowrate forward ± 0.25 % of rate /density (± 1 g/l)																				
Flowrate forward ± 0.15 % of rate /density (± 1 g/l)																				
Flowrate forward-Reverse ± 0.40 % of rate /density (± 5 g/l)																				
Flowrate forward-Reverse ± 0.25 % of rate /density (± 5 g/l)																				
Flowrate forward-Reverse ± 0.15 % of rate /density (± 5 g/l)																				
Flowrate forward-Reverse ± 0.40 % of rate /density (± 1 g/l)																				
Flowrate forward-Reverse ± 0.25 % of rate /density (± 1 g/l)																				
Flowrate forward-Reverse ± 0.15 % of rate /density (± 1 g/l)																				
<b>Instrument Tag / Documentation</b>																				
German																				
English																				
<b>Design Level</b>																				
Specified by ABB																				



**Ordering Information; ME2 – Converter for Remote Design**

Ordering Number	ME2							
<b>Design (Converter)</b>								
Remote Design, in combination with flowmeter primary MC21	1							
<b>Certifications</b>								
None		A						
Ex, CENELEC <sup>1)</sup> (Ambient temperature range -20 °C to +60 °C)		B						
<b>Housing</b>								
Field mount housing, round, connectors M20 x 1.5			1					
Field mount housing, rectangular, connectors M20 x 1.5 <sup>1)</sup>			3					
19" Insert cassette <sup>1)</sup>			5					
<b>Operating Mode/Software Versions</b>								
Standard software (Mass flow and density measurements)				A				
DENSI-MASS-Software (additional concentration calculations) <sup>1)</sup>				C				
<b>Outputs</b> (in addition to Current Output I (active), Contact Output (passive) and Contact Input (passive))								
Current Output 2 (passive), Pulse Output (active) [not available for Ex]					A			
Current Output 2 (passive), Pulse Output (passive)					B			
<b>Communication</b>								
None						0		
HART-Protocol						1		
Profibus-DP Module <sup>1)</sup>						2		
Profibus-PA Module <sup>1)</sup>						3		
FF Module <sup>1)</sup>						5		
<b>Supply Power</b>								
High voltage, 85 to 253 V AC							G	
Low voltage, 24 V AC / 24 V DC							K	
<b>Instrument Tag</b>								
German								G
English								E
French								F

1) In preparation

The Ignition Protection Type „i“ or „e“ is user selectable.

**Questionnaire, Coriolis Mass Flowmeter TRIO-MASS**

<b>Customer:</b>		<b>Date:</b>	
<b>Mr./Mrs./Ms.:</b>		<b>Department:</b>	
<b>Telephone:</b>		<b>Telefax:</b>	
<hr/>			
<b>Fluid:</b>			
	Fluid component:	Gas component:	
<b>Flowrate:</b> (Min, max, operating)	kg/h		
<b>Density:</b> (Min, max, operating)	kg/m <sup>3</sup>		
<b>Dyn. Viscosity:</b> (Min, max, operating)	mPas / cP		
<b>Fluid Temperature:</b> (Min, max, operating)	°C		
<b>Ambient Temperature:</b>	°C		
<b>Pressure:</b> (Min, max, operating)	bar		
<b>Flow:</b>	<input type="checkbox"/> steady	<input type="checkbox"/> pulsating	
<b>Batch Operation:</b>	<input type="checkbox"/> yes	<input type="checkbox"/> no	
<b>Concentration Calculations:</b>	<input type="checkbox"/> yes	<input type="checkbox"/> no	
<b>Converter Design:</b>	<input type="checkbox"/> Compact	<input type="checkbox"/> Remote	
<b>Ex-Protection:</b>	<input type="checkbox"/> yes	<input type="checkbox"/> no	
<b>Supply Power:</b>	High voltage: <input type="checkbox"/> 85 V AC to 253 V AC	Low voltage: <input type="checkbox"/> 24 V AC / 24 V DC	
<b>Electrical Outputs:</b>	<input type="checkbox"/> Current output I: 0/4–20 mA		<b>Communication:</b>
	<input type="checkbox"/> Current output II: 0/4–20 mA		<input type="checkbox"/> Serial data link RS 485
	<input type="checkbox"/> Pulse Output, active		<input type="checkbox"/> Profibus DP
	<input type="checkbox"/> Pulse Output, passive		<input type="checkbox"/> Profibus PA
		<input type="checkbox"/> HART	
<b>Additional Specifications:</b>			
Pipeline diameter	..... mm	..... inch	
Process connections	.....		

