

A

Fit the plug-in device
Rotate the hinges (90°)

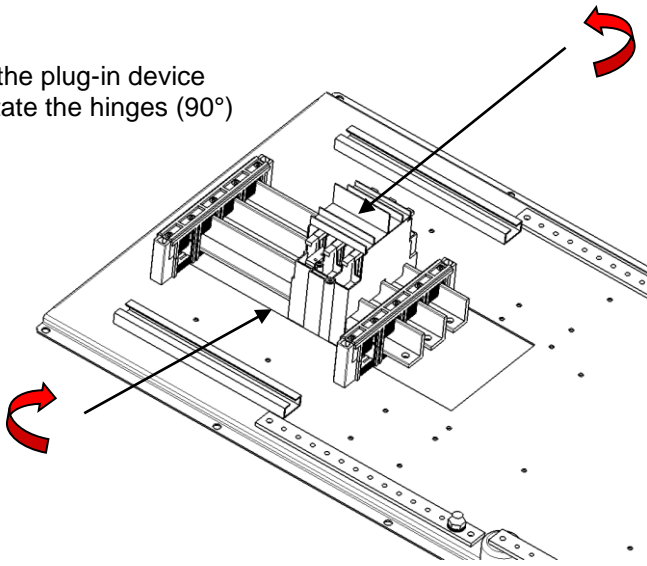

B

Insert busbars shroud

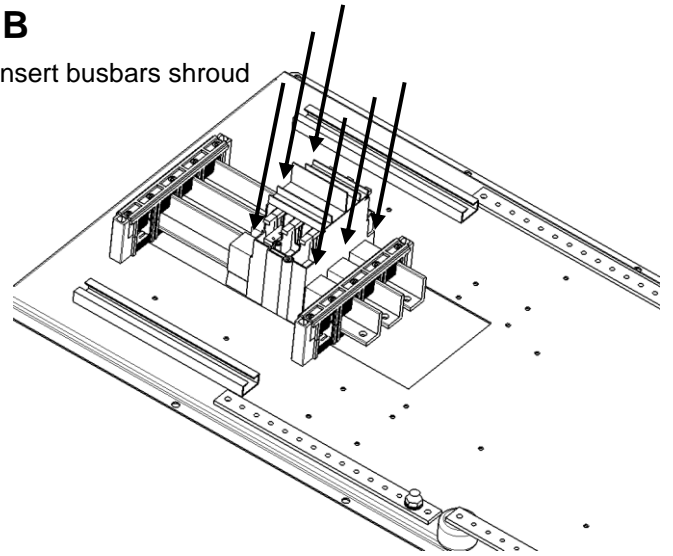

C

Insert the breaker mounting plates

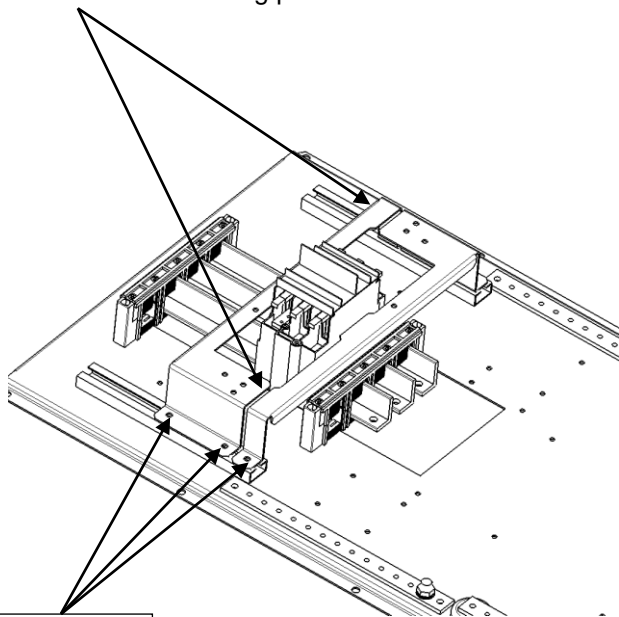

71,2 lb in
8 Nm



D

Install the first breaker
Install the second breaker
Torque the breakers affixing screws
and the brackets screw

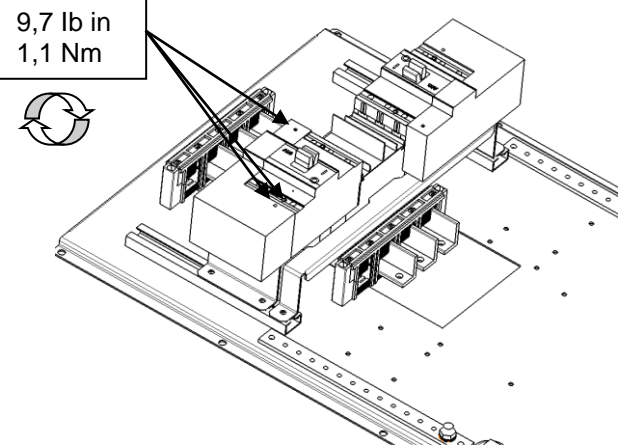

9,7 lb in
1,1 Nm



Torque the breakers terminals

T1	44,5 lb in	5 Nm
T2	53,4 lb in	6 Nm
T3	62,3 lb in	7 Nm