ABB MEASUREMENT & ANALYTICS | DATA SHEET

261GS and 261AS

Gauge and absolute pressure transmitters



Measurement made easy

Engineered solutions for all applications

Standard overload resistance

Base accuracy

- $\pm 0.1 \%$

Span limits

- 0.3 to 60000 kPa; 1.2 in H₂O up to 8700 psi
- 0.3 to 3000 kPa abs; 2.25 mmHg up to 435 psia

Proven sensor technology together with state-of-the-art digital technology

- Large turn down ratio of up to 20:1

Stainless steel housing

- Optimized for use in harsh ambient conditions
- Extremely robust

Flexible configuration options

- Local configuration via setup button for upper and lower range values
- Local configuration via buttons on LCD indicator
- Via handheld terminal or PC user interface

Full compliance with Pressure Equipment Directive (PED) category III

Product in compliance with Directive 2011/65/UE (RoHS II)

Functional specification

Measuring range limits and span limits

Sensor code	Measuring range upper limit (URL)	Measuring range lower limit (LRL) Model 261GS	Minimum measuring span	
			Model 261GS Gauge pressure	Model 261AS Absolute pressure
C	6 kPa 60 mbar 24 inH ₂ O	-6 kPa -60 mbar 24 inH ₂ O	0,3 kPa 3 mbar 1,2 inH ₂ O	0,3 kPa 3 mbar 2,25 mm Hg
F	40 kPa 400 mbar 160 inH ₂ O	-40 kPa -400 mbar -160 inH ₂ O	2 kPa 20 mbar 8 inH ₂ O	2 kPa 20 mbar 15 mm Hg
L	250 kPa 2500 mbar 1000 inH ₂ O	0 abs	12,5 kPa 125 mbar 50 inH ₂ O	12,5 kPa 125 mbar 93,8 mm Hg
D	1000 kPa 10 bar 145 psi	0 abs	50 kPa 500 mbar 7,25 psi	50 kPa 500 mbar 375 mm Hg
U	3000 kPa 30 bar 435 psi	0 abs	150 kPa 1,5 bar 21,7 psi	150 kPa 1,5 bar 21,7 psi
R	10000 kPa 100 bar 1450 psi	0 abs	500 kPa 5 bar 72,5 psi	500 kPa 5 bar 72,5 psi
V	60000 kPa 600 bar 8700 psi	0 abs	3000 kPa 30 bar 435 psi	-

NOTE

The measuring range lower limit (LRL) for model 261AS is absolute 0 for all measuring ranges.

Span limits

To optimize performance characteristics, it is recommended that you select the transmitter sensor code with the lowest turn down ratio.

TURNDOWN = Upper range limit / set span

Zero suppression and elevation

The zero position and span can be set to any value within the measuring range limits listed in the table if:

- Set span \geq minimum span

Damping

Configurable time constant between 0 and 60 s.

This is in addition to the sensor response time, and can be adjusted via the optional LCD indicator, handheld terminal, or PC user interface.

Warm-up time

Ready for operation as per specifications in less than 10 s with minimum damping.

Insulation resistance

>100 M Ω at 500 V DC (between terminals and ground).

Operating limits

Pressure limits

Overpressure limits

No damage will occur during transmitter operation, if they are used within the specifications and subject to the following limits:

Sensor code	Overpressure limits, 0 abs to:
C, F	1 MPa, 10 bar, 145 psi
L	0.5 MPa, 5 bar, 72.5 psi
D	2 MPa, 20 bar, 290 psi
U	6 MPa, 60 bar, 870 psi
R	20 MPa, 200 bar, 2900 psi
V	90 MPa, 900 bar, 13050 psi

Test pressure

When carrying out the transmitter pressure test, it is essential to observe the overpressure limits!

Temperature limits °C (°F)

Environment

Model 261GS, 261AS	Ambient temperature limits
Operating temperature range	-40 to 85 °C (-40 to 185 °F)
White oil filling	-6 to 85 °C (21 to 185 °F)
LCD display	-20 to 70 °C (-4 to 158 °F)

NOTE

For applications in potentially explosive atmospheres, the temperature range specified on the relevant certificate/ approval must be observed.

Process

Model 261GS, 261AS	Process temperature limits
Process temperature range	-50 to 120 °C (-58 to 248 °F)
White oil filling	-6 to 120 °C (21 to 248 °F)

1 ≤ 85 °C (185 °F) for operating pressures below the atmospheric pressure

Storage

Model 261GS, 261AS	Storage temperature range
Storage temperature range	-50 to 85 °C (-58 to 185 °F)
LCD display	-40 to 85 °C (-40 to 185 °F)
White oil filling	-6 to 85 °C (21 to 185 °F)

Model 261GS, 261AS	Humidity during storage
Relative humidity	Up to 75 %

Limits for environmental effects

Electromagnetic compatibility (EMC)

The devices conform to the requirements and tests for EMC Directive 2014/30/UE, as well as EN 61000-6-3 concerning emitted interference and EN 61000-6-1, EN 61000-6-2 concerning interference immunity. The devices fulfill NAMUR recommendations.

Pressure Equipment Directive (PED)

The devices meet the requirements of Directive 2014/68/UE, Category III, module H.

Humidity

Relative humidity: Up to 100 %
Condensation, icing: Permissible

Vibration resistance

Acceleration up to 2 g at frequencies of up to 1000 Hz (according to IEC 60068-2-6).

Shock resistance

Acceleration: 50 g
Duration: 11 ms
(according to 60068-2-27)

Humid and dusty atmospheres (degree of protection)

The transmitter is dust and sand-tight, and is protected against immersion effects as defined by the following standards:

- IEC EN60529 with IP 67 (with IP 68, IP 69K on request)
- NEMA 4X
- JIS C0920

IP65 degree of protection with plug connection

Hazardous atmospheres

ATEX transmitter with type of protection "intrinsic safety Ex ia/ib" in accordance with Directive 2014/34/UE

Transmitter with 4 to 20 mA output signal and HART communication	
Certificate no.	PTB 05 ATEX 2032
Labeling	II 1/2 G Ex ia IIC T4 to T6 Ga/Gb II 2 G Ex ib IIC T4 to T6 Gb

Permissible ambient temperature range according to temperature class:

Ambient temperature	Temperature class
-40 to 85 °C (-40 to 185 °F)	T1 to T4
-40 to 71 °C (-40 to 159 °F)	T5
-40 to 56 °C (-40 to 132 °F)	T6

Or

Labeling	II 1/2 D Ex ia IIIC T66 °C or T95 °C Da/Db II 2 D Ex ib IIIC T66 °C or T95 °C Db
----------	---

Permissible ambient temperature range:

-40 to 85 °C (-40 to 185 °F)

Supply and signal circuit with "Intrinsically safe Ex ia/ib IIB/IIC" type of protection", with the following maximum values

	$U_i = 30 \text{ V}$
	$I_i = 130 \text{ mA}$
	$P_i = 0.8 \text{ W}$
Effective internal capacitance	$C_i = 10 \text{ nF}$
Effective internal inductance	$L_i = 0.5 \text{ mH}$

IECEx transmitter with the following types of protection: "intrinsic safety ia", "non sparking nA" and "dust ignition protection by enclosure tb"

Transmitter with 4 to 20 mA output signal and HART communication	
Certificate no.	IECEx ZLM 10.0002
Labeling	Ex ia IIC T6 bzw. T4 Ga/Gb Ex ia IIIC T66°C bzw. T95°C Da/Db Ex nA IIC T6 bzw. T4 Gc Ex tb IIIC T66°C bzw. T95°C Db

Maximum permissible ambient temperature range according to temperature class

Ambient temperature	Temperature class	Surface temperature
-40 to 85 °C (-40 to 185 °F)	T4	95 °C (203 °F)
-40 to 56 °C (-40 to 133 °F)	T6	66 °C (151 °F)

Electrical data according to designation Ex ia IIC T6 or T4 Ga/Gb and Ex ia IIIC T66°C or T95°C IP6X Da/Db

Supply and signal circuit with "intrinsic safety" Ex ia or Ex ib type of protection, for connection to power supply units with the following maximum values (terminal signal \pm)

	$U_i = 30 \text{ V}$
	$I_i = 130 \text{ mA}$
	$P_i = 0.8 \text{ W}$
Effective internal capacitance	$C_i = 10 \text{ nF}$
Effective internal inductance	$L_i = 0.5 \text{ mH}$

If the transmitter is being integrated into a partition between equipment protection level Ga or Da and a lower protection level, the transmitter must be supplied with power by an Ex ia intrinsically safe circuit.

Electrical data according to designation Ex nA IIC T6 or T4 Gc and Ex tb IIIC T66°C or T95°C IP6X Db

	$I_N \leq 22,5 \text{ mA}$
	$U_N \leq 45 \text{ V}$

...Operating limits

Factory Mutual (FM)

Transmitter with 4 to 20 mA output signal and HART communication	
Intrinsic Safety	Class I; II and III; Division 1; Groups A, B, C, D; E, F, G Class I; Zone 0; AEx ia Group IIC T6; T4
Non-incendive	Class I, II, III, Division 2; Groups A, B, C, D, F, G
Degree of protection	NEMA type 4X (indoor and outdoor installation)

Canadian Standards Association (CSA)

Transmitter with 4 to 20 mA output signal and HART communication	
Intrinsic Safety	Class I; II and III; Division 1; Groups A, B, C, D; E, F, G Class I; Zone 0; Group IIC T6; T4
Non-incendive	Class I, II, III; Division 2; Groups A, B, C, D; F, G
Degree of protection	NEMA type 4X (indoor and outdoor installation)

Permissible ambient temperature range according to temperature class:

U_i max. = 30 V; I_i max = 130 mA; P_i = 0,8 W; C_i = 10 nF; L_i = 0,5 μ H			
Ex ia II CT1 to T6	T6	T5	T1 to T4
	-40 to 56 °C	-40 to 71 °C	-40 to 85 °C

Intrinsic safety	Gas and dust, order code X4
Degree of protection	Ex ia II CT1~T6; DIP A20 TA 95 °C

Electrical data and options

HART digital communication and 4 to 20 mA output

Power supply

The transmitter operates from 11 to 42 V DC with no load and is protected against reversed polarity (additional loads enable operation above 42 V DC).

During use in Ex ia zones and in other intrinsically safe applications, the power supply must not exceed 30 V DC.

Ripple

Maximum permissible supply voltage ripple during communication: Complies with HART FSK "Physical Layer" specification rev. 8.1.

Load limitations

Total loop resistance at 4 to 20 mA and HART:

$$R(k\Omega) = \frac{\text{Voltage supply} - \text{Minimum operating voltage (VDC)}}{23.6 \text{ mA}}$$

A minimum resistance of 250 Ω is required for HART communication

LCD display (optional)

Digital, graphic LCD display for customized visualization of:

- Gauge pressure/absolute pressure
- Output current in mA or %, or
- HART output (freely assigned start/end values and unit)

Diagnostic messages, alarms, errors, and measuring range upper limit violations are also displayed.

In addition, the LCD display can be used to configure and parameterize the transmitter using 4 buttons.

Output signal

Two-wire, 4 to 20 mA output.

HART® communication provides digital process variables (% , mA or engineering units) superimposed on the 4 to 20 mA signal (protocol according to Bell 202 FSK standard).

Output current limits (according to NAMUR standard)

Overload condition

- Lower limit: 3.8 mA (configurable up to 3.5 mA)
- Upper limit: 20.5 mA (configurable up to 23.6 mA)

Alarm current

- Minimum alarm current: 3.5 mA (configurable from 3.5 to 4 mA)
- Maximum alarm current: 21 mA (configurable from 20 to 23.6 mA)

Maximum alarm current: 21 mA (configurable from 20 to 23.6 mA)

Default setting: High Alarm Current

SIL: Functional safety (optional)

According to IEC 61508/61511

Device with certificate of conformity for use in safety-related applications, up to and including SIL 2.

Measuring accuracy

Reference conditions according to IEC 60770

- Ambient temperature TU = constant in the range 18 to 30 °C (64 to 86 °F)
- Relative humidity = constant in the range 30 to 80 %
- Ambient pressure PU = constant in the range 950 to 1060 mbar.
- Measuring span based on zero position
- Transmitter with ceramic or Hastelloy separation diaphragm
- Filling fluid: Silicone oil
- Supply voltage: 24 V DC
- Load with HART: 250 Ω
- Transmitter not grounded
- Characteristic setting: linear, 4 to 20 mA.

Unless otherwise stated, errors are specified as a % of the measuring span value.

The accuracy of the measurement in relation to the upper range limit (URL) is affected by the turndown (TD); i.e., the ratio of the upper range limit (URL) to the set span (URL/ span).

FOR OPTIMUM MEASURING ACCURACY, IT IS RECOMMENDED THAT YOU SELECT THE SENSOR CODE WHICH WILL PROVIDE THE LOWEST TD VALUE.

Dynamic response (according to IEC 61298-1)

Reaction time	100 ms
Time constant (63.2 % of total step response)	150 ms

Measuring error for setting cut-off point

Turndown	Measuring error
1:1 to 10:1	± 0.1 %
>10:1	± (0.1 + 0.005 x TD - 0.05) %

Ambient temperature

Thermal change in ambient temperature as regards the zero signal and span (turndown up to 6:1), in relation to the set span

Temperature range	Maximum effect on zero signal and span
-10 to 60 °C (14 to 140 °F)	All measuring ranges ± (0.2 % x TD + 0.2 %)
-40 to -10 °C (-40 to 14 °F)	All measuring ranges ±((0.1 % / 10 K) x TD + (0.1 / 10K))
60 to 85 °C (140 to 185 °F)	

Temperature coefficient (Tk)

Effect of the ambient temperature per 10 K (but limited to the maximum effect of the temperature change, see previous information). The information refers to the set measuring span.

Temperature range	Effect on zero signal and span
-10 to 60 °C (14 to 140 °F)	Sensor code C, F: ± (0.15 % x TD + 0.15 %)
	Sensor code L, D, U, R, V: ± (0.05 % x TD + 0.05 %)

Power supply

Within the specified limits for the voltage / load, the total influence is less than 0.001 % of the upper measuring range limit per volt.

Load

Within the specified load / voltage limits, the total influence is negligible.

Electromagnetic fields

Total influence is less than 0.3 % of measuring span from 80 to 1000 MHz and for field strengths up to 10 V/m when tested with unshielded conduit, with or without meter.

Mounting position

Nominal position: vertical; process connection at bottom. Mounting position deviant from the standard position influence the output due to the filling liquid. With a deviation of 90° from standard position the effect is 1.12 mbar + 0.01 mbar/10K.

This effect can be compensated by carrying out zero signal adjustment and configuring the mounting angle with the LCD indicator or DTM.

Long-term stability

±(0.10 x TD) % / year

Vibration effect

±(0.10 x TD) % acc. to IEC 61298-3

Total performance

Similar to DIN 16086

In the range -10 to 60 °C (14 to 140 °F):

0.42% of the set span (TD 1:1)

The total performance accuracy includes the measuring error (non-linearity including hysteresis and non-reproducibility), as well as the thermal change in the ambient temperature as regards the zero signal and span.

$$E_{perf} = \sqrt{(E_{\Delta TS1} + E_{\Delta TS2})^2 + E_{lin}^2}$$

E_{perf} = Base accuracy

$E_{\Delta TS1}$ = Effect of the ambient temperature on the URL

$E_{\Delta TS2}$ = Effect of the ambient temperature on the measuring span

E_{lin} = Measuring error (for setting cut-off point)

Technical specification

(Please refer to the order information to check the availability of different versions of the relevant model)

Materials

Process separation diaphragms*

Hastelloy C276, Hastelloy C276 gold plated,
Stainless steel (1.4435 / 316L)

Process connection¹

Stainless steel (1.4404 / 316L)

Sensor filling fluid

Silicone oil, inert fill (fluorocarbon), white oil (FDA)

Mounting bracket

Stainless steel

Sensor housing, electronics housing and cover

Stainless steel (1.4404 / 316L)

Filter for atmospheric ventilation

Filter housing: plastic (standard), stainless steel
(code EA, AB)

Filter material: polyamide (PA)

Viewing window in cover (LCD display)

Polycarbonate, Makrolon 6557

Cover O-ring

EPDM

Plates

Plastic data plate attached to the electronics housing

Calibration

Standard: 0 to upper range limit (URL)

Optional: To specified measuring span

Optional extras

Mounting bracket

For vertical and horizontal 60 mm (2 in.) pipes or wall mounting

LCD display

Can be rotated in 90° increments into 4 positions

Additional tag plates

Code I2: For measuring point tag (up to 30 characters) and calibration specifications (up to 30 characters: lower and upper value plus unit), attached to transmitter housing.

Code I1: For customer data (4 lines with 30 characters each), attached to transmitter housing with wire.

Cleaning stage for oxygen applications (O2)

Certificates (test, design, characteristics, material traceability)

Name plate and operating instruction language

Communication plug connectors

Process connections

1/2-14 NPT female or male thread, DIN EN 837-1 G 1/2 B or G 1/2 B (HP) for convex seal, flush diaphragm, for installation in ball valve.

* Wetted parts of the transmitter.

Electrical connections

M16 x 1.5 tap hole with cable gland (cable diameter approx. 5 to 10 mm), directly on housing
or
M20 x 1.5 (via adapter) with cable gland (cable diameter approx. 6 to 11 mm)
or
1/2-14 NPT (via adapter) without cable gland

Terminals

HART version:
Two connections for signal / auxiliary power, for wire cross-sections from 0.5 to 1.5 mm² (16 AWG)

Grounding (optional)

External ground terminals for wire cross-sections up to 4 mm² (12 AWG).

Weight

(without options)

- Approx. 0.7 kg (1.54 lb)
- Additional 650 g (1.5 lb)

Packaging

Carton with dimensions of approx. 240 x 140 x 190 mm (9.45 x 5.51 x 7.48 in.)

Configuration

Transmitter with HART communication and 4 to 20 mA

Standard configuration

Transmitters are set to the customer's specified span at the factory. The set range and measuring point number are provided on the name plate. If this data has not been specified, the transmitter will be delivered with the following configuration:

Parameter	Factory setting
4 mA	Zero position
20 mA	Measuring range upper limit (URL)
Output	Linear
Damping	0.1 s
Transmitter failure mode	21 mA
Optional LCD display	0 to 100 %

Any or all of the configurable parameters listed above - including the upper and lower range values - can easily be changed using the optional LCD indicator, a HART handheld communicator, or a PC running the configuration software SMART VISION with DTM for 2600T.

Mounting dimensions

(No design information) — dimensions in mm (inches)

Standard Version

Dimensions standard design

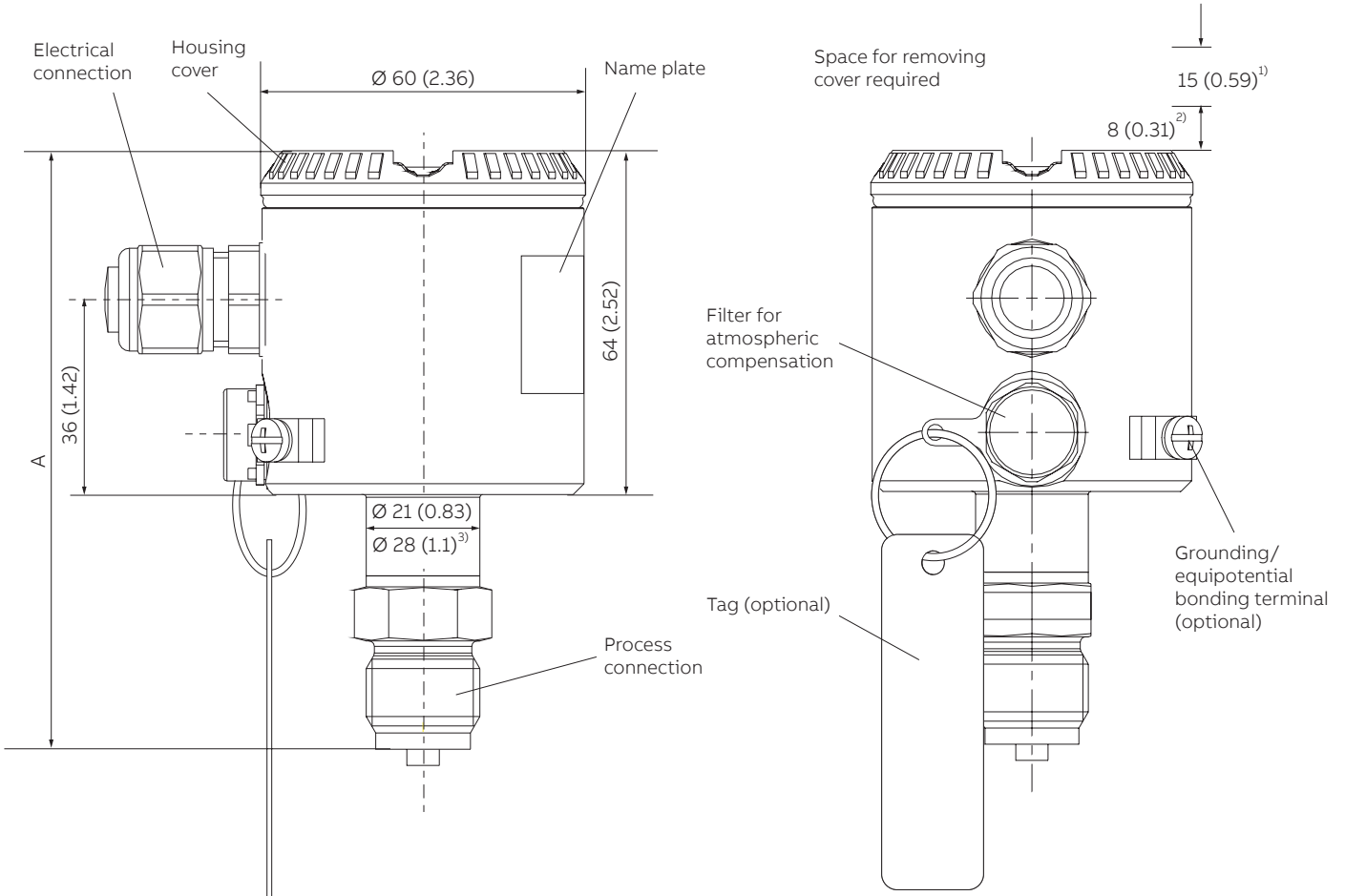

M10684-01

- (1) Clearance for cover removal required
- (2) With LCD indicator
- (3) Dimensions for sensor code C, F

Dimension "A" is dependent on the process connection as per the following table:

Process connection	Dimension "A" in mm (inch)
1/2-14 NPT male thread	111 (4.37)
1/2-14 NPT female thread	106 (4.17) / (110 (4.33) sensor V)
DIN EN 837-1 G 1/2 B	111 (4.37)
DIN EN 837-1 G 1/2 B (HP) for connections with convex seal	121 (4.76)

Version with the options “LCD indicator” and “Harting Han plug”

Dimensions with options

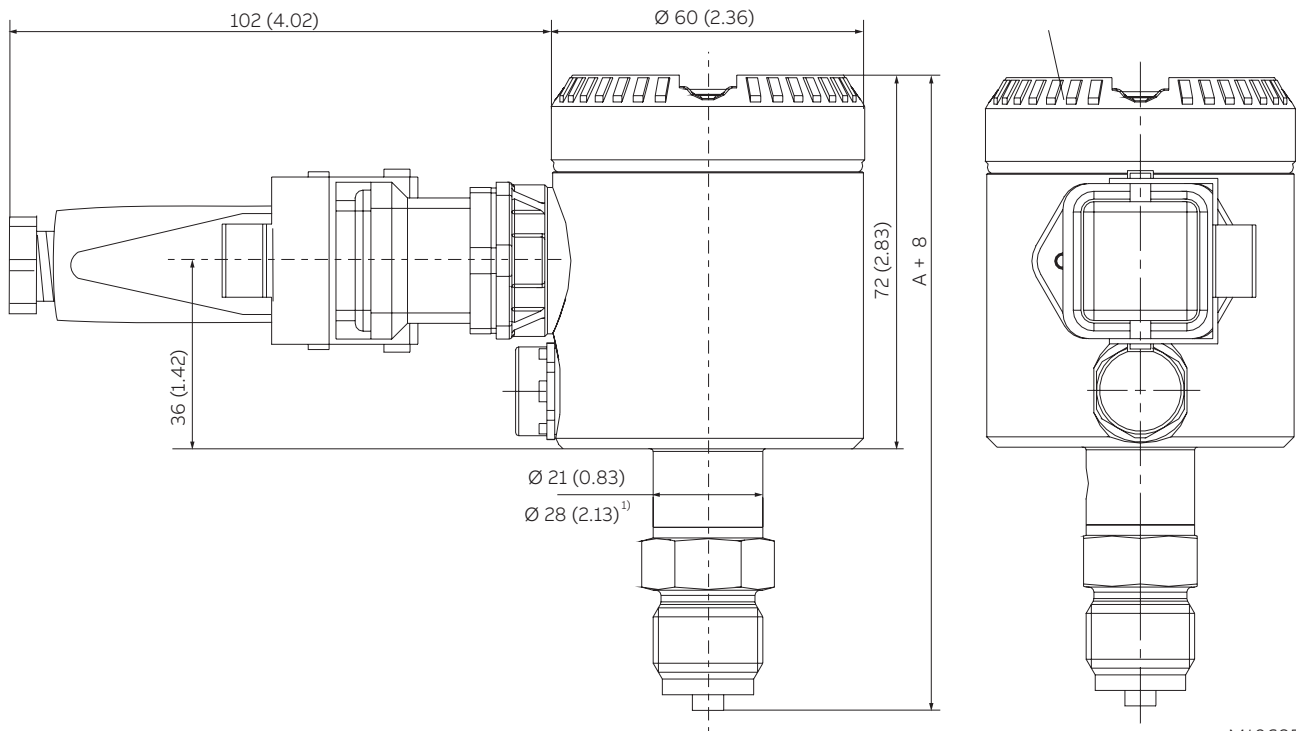

M10685-01

(1) Housing cover for LCD indicator option

(1) Dimensions for sensor code C, F

Dimension "A" is dependent on the process connection as per the following table:

Process connection	Dimension "A" in mm (inch)
1/2-14 NPT male thread	111 (4.37)
1/2-14 NPT female thread	106 (4.17) / (110 (4.33) sensor V)
DIN EN 837-1 G 1/2 B	111 (4.37)
DIN EN 837-1 G 1/2 B (HP) for connections with convex seal	121 (4.76)

...Mounting dimensions

Transmitter with flush diaphragm

Dimensions - With flush diaphragm

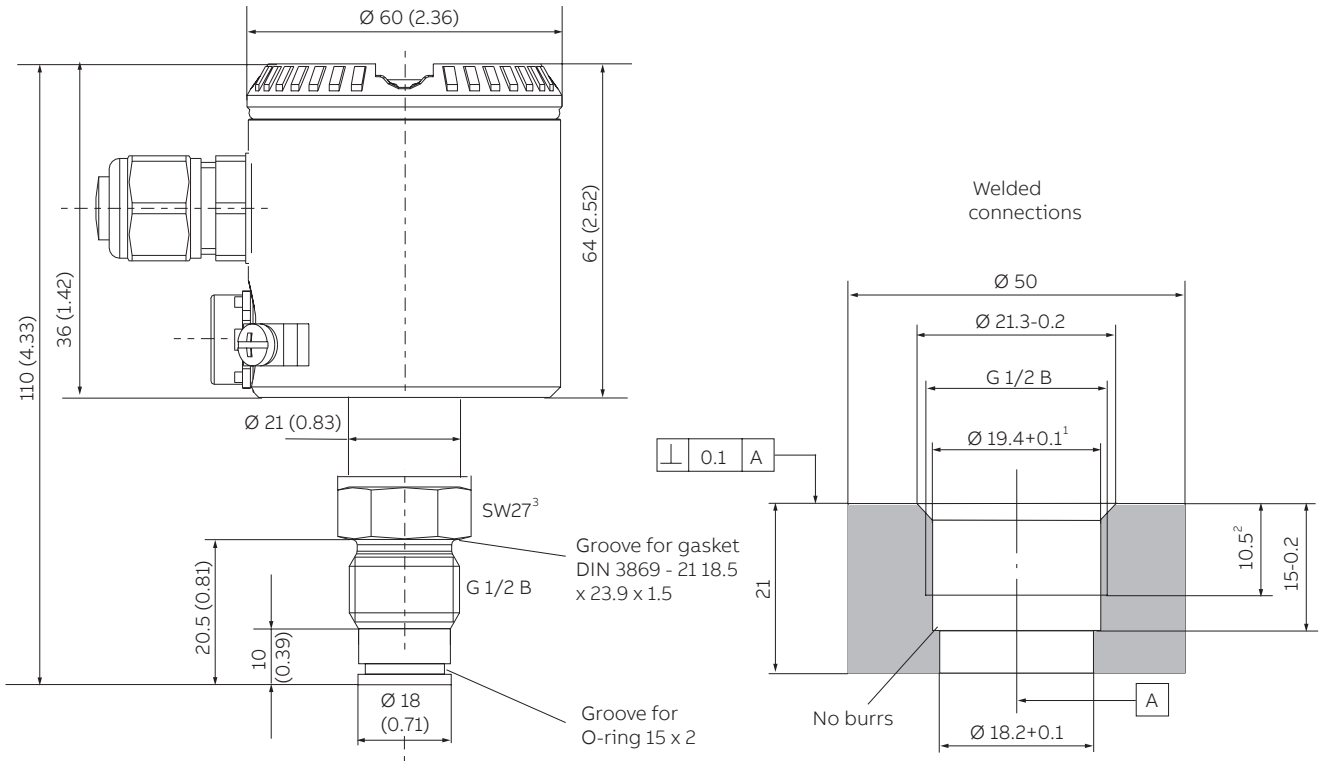

M10686

2)

- (1) Bevel after cutting threads
- (2) Minimum dimension
- (3) Wrench size 27

Version with ball valve connection

Dimensions - With ball valve connection

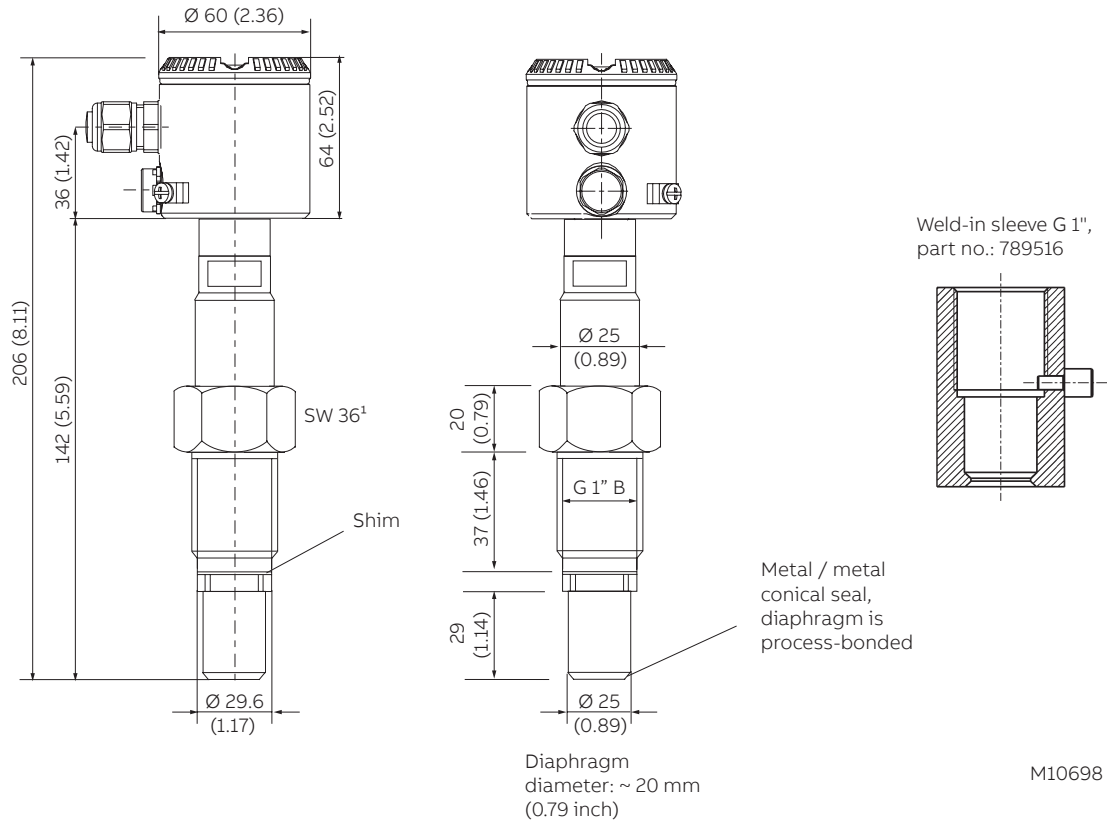

(1) Wrench size 36

...Mounting dimensions

Dimensions in mm (inch) - with options

Mounting with angle bracket (optional)

Dimensions — pipe mounting/wall mounting

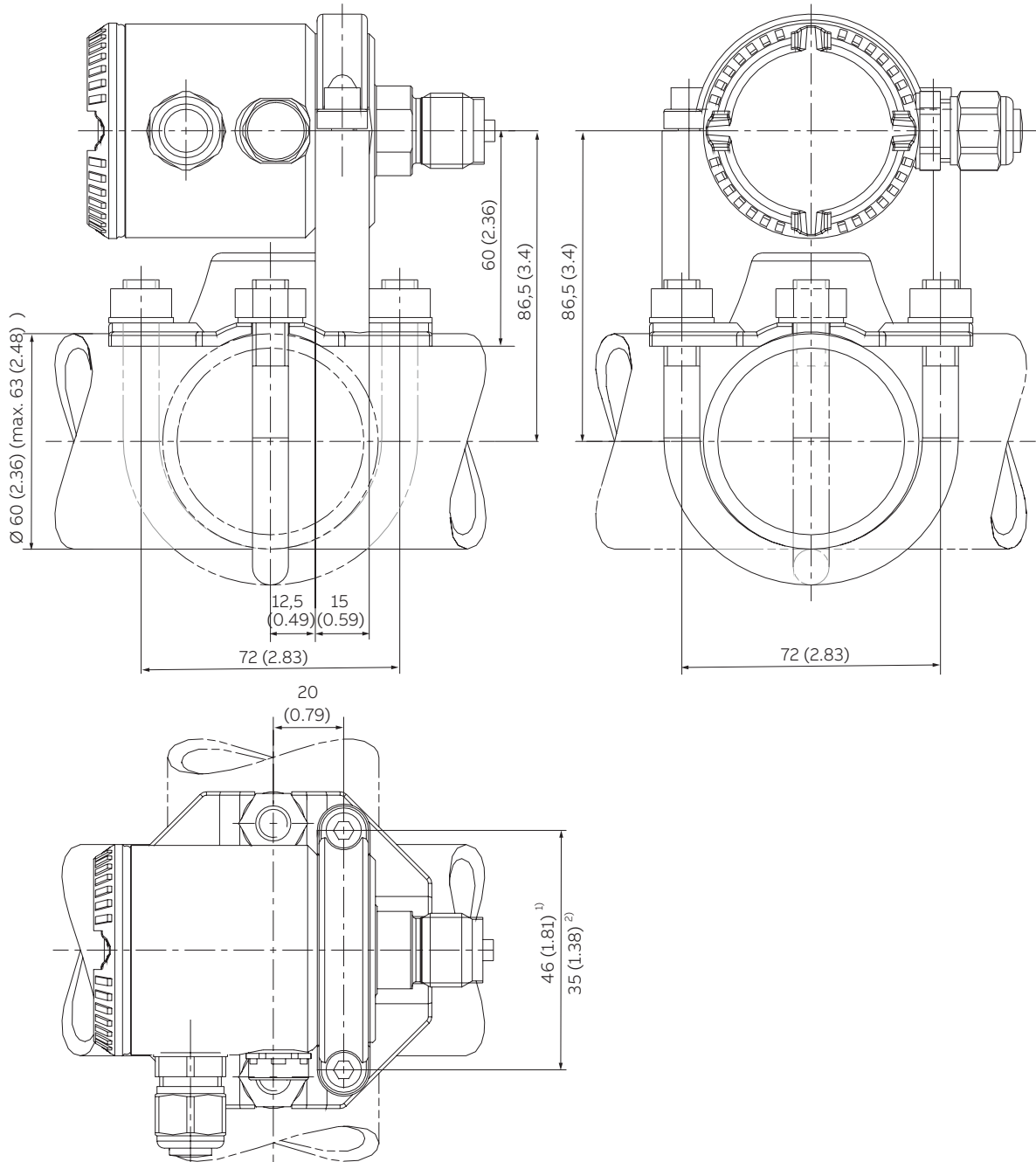

M10688-01

(1) Dimensions for sensor code C, F

(2) Sensor code L, D, U, 1, R, V

NOTE

The bracket for wall or pipe mounting has four holes with a Ø of 10.5 mm. The holes are arranged in a square and spaced 72 mm away from one another.

Electrical connections

HART version

Electrical connections - HART version

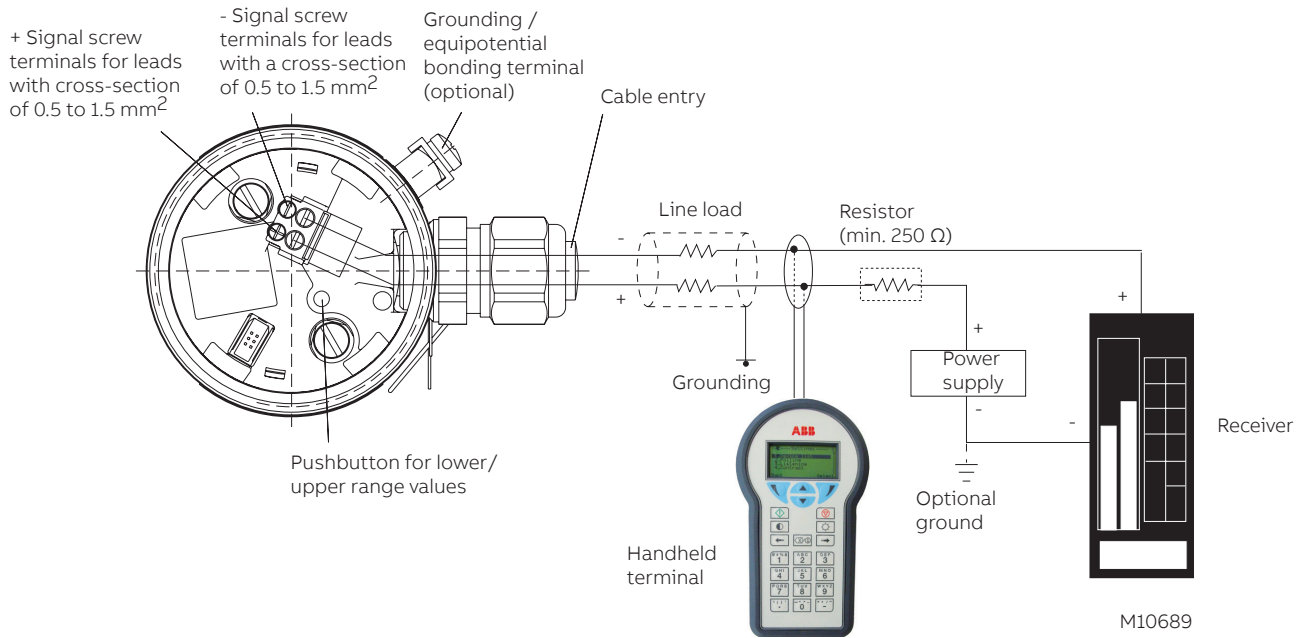

Ordering Information

Basic ordering information model 261GS Pressure Transmitters

Select one character or set of characters from each category and specify complete catalog number.

Refer to additional ordering information and specify one or more codes for each transmitter if additional options are required.

Base model 1 st to 5 th characters				261GS	X	X	X	X	X	X
Gauge pressure transmitter, compact class, base accuracy 0.1 %										
Sensor - Span Limits – 6th characters										
6 kPa	60 mbar	24 in. H ₂ O (45 mm Hg)			C					
40 kPa	400 mbar	160 in. H ₂ O (300 mm Hg)			F					
250 kPa	2500 mbar	1000 in. H ₂ O (1875 mm Hg)			L					
1000 kPa	10 bar	145 psi			D					
3000 kPa	30 bar	435 psi			U					
10000 kPa	100 bar	1450 psi			R					
60000 kPa	600 bar	8700 psi			V					
Diaphragm Material / Fill Fluid – 7th characters										
Hastelloy C-276	Silicone oil	NACE							K	
Hastelloy C-276 gold-plated	Silicone oil	NACE	(Note: 1)						G	
AISI 316L SST (1.4435)	Silicone oil	NACE	(Note: 2)						S	
Hastelloy C-276	Inert Fluid	NACE	(Note: 3)						F	
Hastelloy C-276 gold-plated	Inert fluid	NACE	(Note: 4)						E	
AISI 316L SST (1.4435)	Inert fluid	NACE	(Note: 2)						A	
Hastelloy C-276	White oil (FDA)	NACE							Z	
AISI 316L SST (1.4435)	White oil (FDA)	NACE	(Note: 2)						N	
Process Connection Material / Process Connection – 8th characters										
AISI 316L SST (1.4404)	1/2-14 NPT female	NACE								B
AISI 316L SST (1.4404)	DIN EN 837-1 G 1/2 B	NACE								P
AISI 316L SST (1.4404)	G 1/2 in. front bonded diaphragm	NACE	(Notes: 1,8)							S
AISI 316L SST (1.4404)	1/2-14 NPT male	NACE								T
AISI 316L SST (1.4404)	DIN EN 837-1 G 1/2 B (HP)	NACE	(Note: 1)							U
AISI 316L SST (1.4404)	For ball valve connection	NACE	(Note: 1)							V
AISI 316L SST (1.4404)	DIN 16288 M20 x 1,5	NACE								L
Gasket – 9th characters										
None, NACE										N
Electronic Housing Material / Electrical Connection – 10th characters										
AISI 316L SST (1.4404) / M16 x 1.5 (with cable gland made of plastic)				(Note: 5)						2
AISI 316L SST (1.4404) / 1/2-14 NPT (without cable gland)				(Note: 6)						S
AISI 316L SST (1.4404) / M20 x 1.5 (with cable gland made of plastic)				(Note: 5)						T
Output – 11th characters										
HART digital communication and 4 to 20 mA (Additional options to be ordered by additional ordering code)										1

Additional ordering information for model 261GS

Add one or more 2-digit code(s) after the basic ordering information to select all required options.

	XX	XX	XX	XX	XX	XX	XX
Explosion Protection Certification							
Factory Mutual (FM) - Intrinsically Safe (Note: 10)	EA						
Canadian Standard Association (CSA) - Intrinsically Safe (Note: 10)	ED						
ATEX Group II Category 1/2 G - Intrinsic Safety EEx ia	EH						
ATEX Group II Category 1/2 G and 1/2 D - Intrinsic Safety EEx ia (without Cable Gland) (Note: 10)	EL						
IECEX Ex ia IIC T6 + Ex nA IIC T6, Gas	ER						
IECEX Ex ia IIC T6 + Ex nA IIC T6 + Ex tb. Gas & Dust	ES						
Integrated Digital Display (LCD)							
With integrated LCD display	L1						
Electronic Housing: Ground Terminal							
Housing with external grounding terminal		AA					
Electronic Housing: Cable Gland							
Cable Gland M16 x 1.5 / M20 x 1.5 and atmosphere ventilation of metal				AB			
Mounting Bracket Shape / Material							
For pipe mounting / AISI 304 SST (1.4301)						B2	
For wall mounting / AISI 304 SST (1.4301)						B4	
Applications: Oxygen							
Oil- and grease-free, for oxygen applications (O ₂) (Pmax = 10 MPa / 100 bar / 1450 psi, Tmax = 60 °C / 140 °F) (Note: 11)							P1
Operating Instruction Language							
German							M1
Italian							M2
Spanish							M3
French							M4
English							M5
Portuguese							MA
Russian							MB

Additional ordering information for model 261GS

	XX	XX
Material: 3.1 Inspection		
Inspection certificate 3.1 acc. EN 10204 of process wetted parts (Note: 13)	H1	
Material: 2.2 Test Report		
Test report 2.2 acc. EN 10204 of the pressure bearing and process wetted parts		H4

- Note 1: Not available with Sensor code C, F
 Note 2: Only with Front Bonded Diaphragm
 Note 3: Suitable for oxygen applications
 Note 4: Suitable for oxygen applications / Not available with Sensor code C, F
 Note 5: With Cable Gland made of Plastic
 Note 6: Without cable gland
 Note 7: Deleted
 Note 8: Not available with Hastelloy C-276 gold plated diaphragm
 Note 9: Deleted
 Note 10: Not available with electrical connection with connector
 Note 11: Only available with inert fill
 Note 12: Only with Fill Fluid White oil
 Note 13: Minor parts with factory certificate acc. EN 10204
 Note 14: Deleted

Standard delivery scope (changes possible with additional ordering code)

- For general-purpose applications (no Ex applications)
- Buna O-ring for G 1/2 process connection, flush diaphragm
- No display, no mounting bracket
- English-language operating instructions; English and German-language labels
- Configuration with kPa and °C units
- No test, inspection, or material certificates

Unless otherwise specified prior to manufacture, the customer shall be responsible for the selection of suitable parts that make contact with the medium and appropriate filling fluids in order to ensure compatibility with the relevant process medium.

Ordering Information

Basic ordering information model 261AS Absolute Pressure Transmitters

Select one character or set of characters from each category and specify complete catalog number.

Refer to additional ordering information and specify one or more codes for each transmitter if additional options are required.

Base model 1 st to 5 th characters Absolute pressure transmitter, compact class, base accuracy 0.1 %	261AS	X	X	X	X	X	X
Sensor - Span Limits – 6th characters							
6 kPa 60 mbar 24 in. H ₂ O (45 mm Hg)		C					
40 kPa 400 mbar 160 in. H ₂ O (300 mm Hg)		F					
250 kPa 2500 mbar 1000 in. H ₂ O (1875 mm Hg)		L					
1000 kPa 10 bar 145 psi		D					
3000 kPa 30 bar 435 psi		U					
10000 kPa 100 bar 1450 psi		R					
Diaphragm Material / Fill Fluid – 7th characters							
Hastelloy C-276 Silicone oil NACE						K	
Hastelloy C-276 gold-plated Silicone oil NACE	(Note: 1)					G	
AISI 316L SST (1.4435) Silicone oil NACE	(Note: 2)					S	
Hastelloy C-276 Inert Fluid NACE	(Note: 3)					F	
Hastelloy C-276 gold-plated Inert fluid NACE	(Note: 4)					E	
AISI 316L SST (1.4435) Inert fluid NACE	(Note: 2)					A	
Hastelloy C-276 White oil (FDA) NACE						Z	
AISI 316L SST (1.4435) White oil (FDA) NACE	(Note: 2)					N	
Process Connection Material / Process Connection – 8th characters							
AISI 316L SST (1.4404) 1/2-14 NPT female NACE						B	
AISI 316L SST (1.4404) DIN EN 837-1 G 1/2 B NACE						P	
AISI 316L SST (1.4404) G 1/2 in. front bonded diaphragm NACE	(Notes: 1,8)					S	
AISI 316L SST (1.4404) 1/2-14 NPT male NACE						T	
AISI 316L SST (1.4404) DIN EN 837-1 G 1/2 B (HP) NACE	(Note: 1)					U	
AISI 316L SST (1.4404) For ball valve connection NACE	(Note: 1)					V	
AISI 316L SST (1.4404) DIN 16288 M20 x 1,5 NACE						L	
Gasket – 9th characters							
None, NACE							N
Electronic Housing Material / Electrical Connection – 10th characters							
AISI 316L SST (1.4404) / M16 x 1.5 (with cable gland made of plastic)	(Note: 5)						2
AISI 316L SST (1.4404) / 1/2-14 NPT (without cable gland)	(Note: 6)						S
AISI 316L SST (1.4404) / M20 x 1.5 (with cable gland made of plastic)	(Note: 5)						T
Output – 11th characters							
HART digital communication and 4 to 20 mA (Additional options to be ordered by additional ordering code)							1

Additional ordering information for model 261AS

Add one or more 2-digit code(s) after the basic ordering information to select all required options.

	XX	XX	XX	XX	XX	XX	XX
Explosion Protection Certification							
Factory Mutual (FM) - Intrinsically Safe (Note: 10)	EA						
Canadian Standard Association (CSA) - Intrinsically Safe (Note: 10)	ED						
ATEX Group II Category 1/2 G - Intrinsic Safety EEx ia	EH						
ATEX Group II Category 1/2 G and 1/2 D - Intrinsic Safety EEx ia (without Cable Gland) (Note: 10)	EL						
IECEX Ex ia IIC T6 + Ex nA IIC T6, Gas	ER						
IECEX Ex ia IIC T6 + Ex nA IIC T6 + Ex tb. Gas & Dust	ES						
Integrated Digital Display (LCD)							
With integrated LCD display		L1					
Electronic Housing: Ground Terminal							
Housing with external grounding terminal			AA				
Electronic Housing: Cable Gland							
Cable Gland M16 x 1.5 / M20 x 1.5 and atmosphere ventilation of metal				AB			
Mounting Bracket Shape / Material							
For pipe mounting / AISI 304 SST (1.4301)						B2	
For wall mounting / AISI 304 SST (1.4301)						B4	
Applications: Oxygen							
Oil- and grease-free, for oxygen applications (O2) (Pmax = 10 MPa / 100 bar / 1450 psi, Tmax = 60 °C / 140 °F) (Note: 11)							P1
Tag and certification stainless steel plates and laser printing							
German							M1
Italian							M2
Spanish							M3
French							M4
English							M5
Portuguese							MA
Russian							MB

Additional ordering information for model 261AS

	XX	XX
Material: 3.1 Inspection		
Inspection certificate 3.1 acc. EN 10204 of process wetted parts (Note: 13)	H3	
Material: 2.2 Test Report		
Test report 2.2 acc. EN 10204 of the pressure bearing and process wetted parts		H4

- Note 1: Not available with Sensor code C, F
 Note 2: Only with Front Bonded Diaphragm
 Note 3: Suitable for oxygen applications
 Note 4: Suitable for oxygen applications / Not available with Sensor code C, F
 Note 5: With Cable Gland made of Plastic
 Note 6: Without cable gland
 Note 7: Deleted
 Note 8: Not available with Hastelloy C-276 gold plated diaphragm
 Note 9: Deleted
 Note 10: Not available with electrical connection with connector
 Note 11: Only available with inert fill
 Note 12: Only with Fill Fluid White oil
 Note 13: Minor parts with factory certificate acc. EN 10204
 Note 14: Deleted
 Note 15: Not available with sensor code C, if calibrated at TD higher than 2

Standard delivery scope (changes possible with additional ordering code)

- For general-purpose applications (no Ex applications)
- Buna O-ring for G 1/2 process connection, flush diaphragm
- No display, no mounting bracket
- English-language operating instructions; English and German-language labels
- Configuration with kPa and °C units
- No test, inspection, or material certificates

Unless otherwise specified prior to manufacture, the customer shall be responsible for the selection of suitable parts that make contact with the medium and appropriate filling fluids in order to ensure compatibility with the relevant process medium.

Notes

ABB Ltd.**Measurement and Analytics**

Howard Road St. Neots
Cambridgeshire PE19 8EU
UK

Tel: +44 (0)870 600 6122

Fax: +44 (0)1480 213 339

Email: enquiries.mp.uk@gb.abb.com

ABB S.p.A.**Measurement and Analytics**

Via Luigi Vaccani 4
22016 Tremezzina (CO)
Italy

Tel: +39 0344 58111

ABB Inc.**Measurement and Analytics**

125 E. County Line Road
Warminster PA 18974
USA

Tel: +1 215 674 6000

Fax: +1 215 674 7183

abb.com/measurement

We reserve the right to make technical changes or modify the contents of this document without prior notice. With regard to purchase orders, the agreed particulars shall prevail. ABB does not accept any responsibility whatsoever for potential errors or possible lack of information in this document.

We reserve all rights in this document and in the subject matter and illustrations contained therein. Any reproduction, disclosure to third parties or utilization of its contents – in whole or in parts – is forbidden without prior written consent of ABB.