

Emax-Tmax

DOC. N.° 1SDH000529R0812

L3667

Parte fissa di interruttore estraibile T7-T7M UL
 Fixed part of withdrawable circuit-breaker T7-T7M UL
 Unterteil des ausfahrbaren Leistungsschalters T7-T7M UL
 Partie fixe de disjoncteur débrochable sur chariot T7-T7M UL
 Parte fija de interruptor extraíble T7-T7M UL

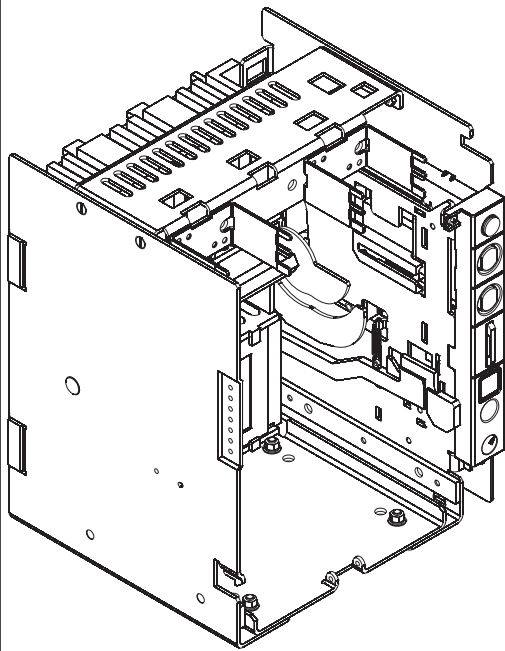
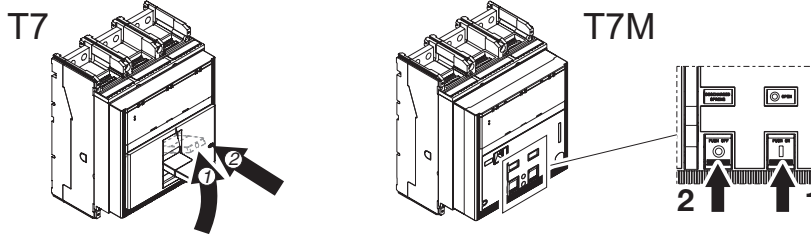

FISSAGGIO PARETE WALL MOUNTING WANDMONTAGE FIXATION SUR PARI FIJACIÓN DE PARED	FISSAGGIO PAVIMENTO FLOOR MOUNTING BODENMONTAGE FIXATION AU SOL FIJACIÓN DE PISO
X4	X4
X4	X4
X4	X4

X4

X4

X4

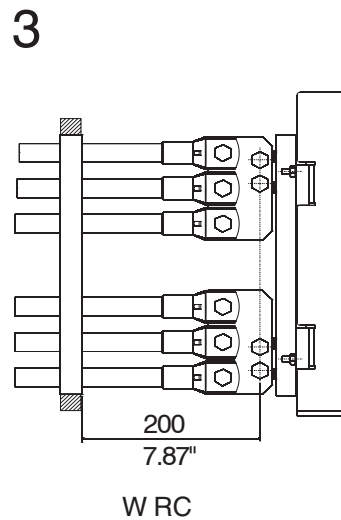
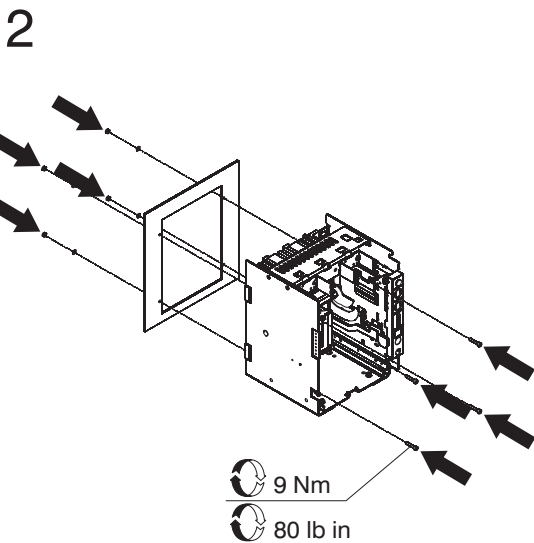
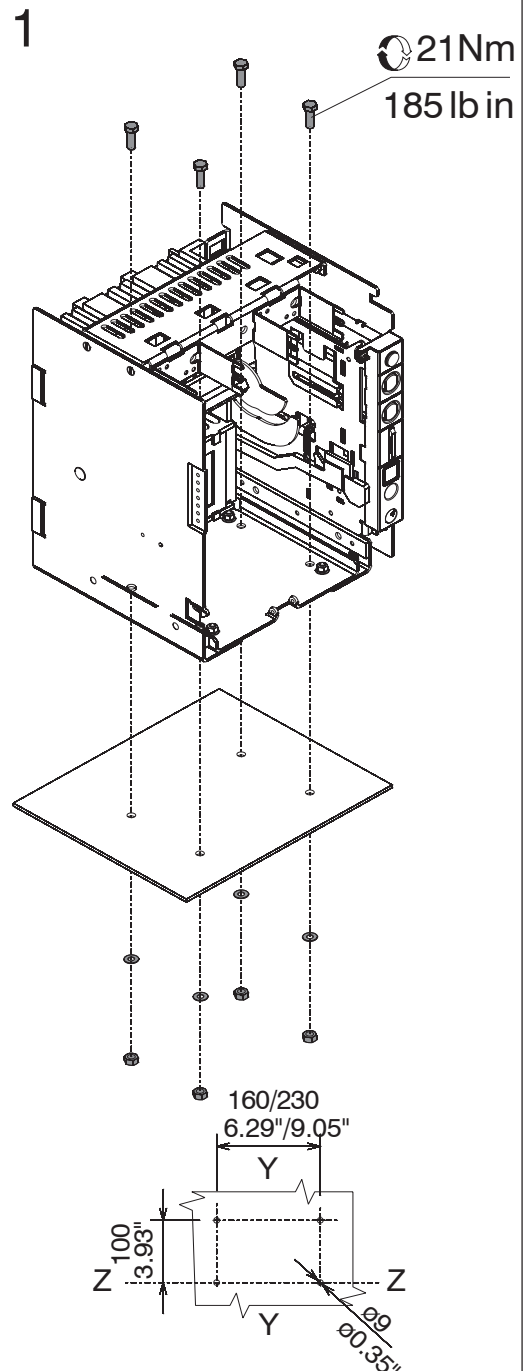

4

Connessione ai circuiti ausiliari
 Connection to auxiliary circuits
 Anschluss an die Hilfsstromkreise
 Connexion aux circuits auxiliaires
 Conexión con los circuitos auxiliares

D1	C1	C13	C12	42	11	12	22	31	32
D2	C2	C3	C11	44	41	14	24	21	34

T9	T7	T6	W4	98S	W2	K15	K13	K21	K2	T3	T4
T10	T8	T5	W3	95S	W1	K14	K12	K11	K1	T2	T1

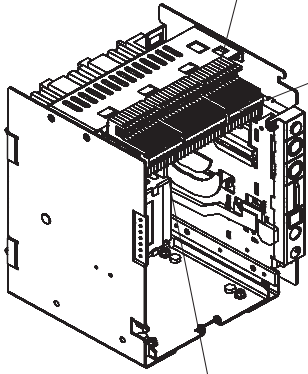

U1	38		98		R1	48					T7M
U2	36	35	95	96	R2	46	45				

77	67	57	98								T7
78	68	58	95	96							

5

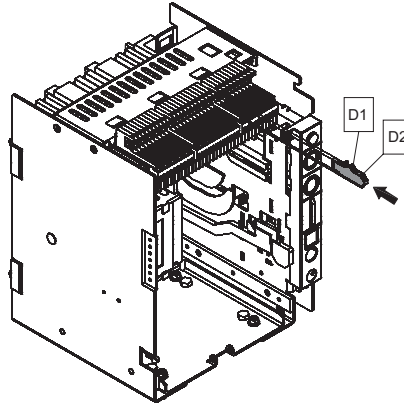
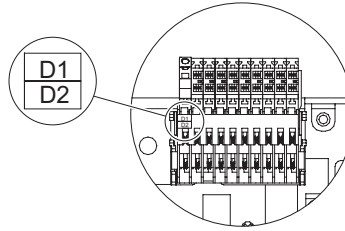

Esempio di cablaggio per parte fissa
 Wiring example for fixed part
 Verdrahtungsbeispiel für Unterteil
 Exemple de câblage pour partie fixe
 Ejemplo de cableado para parte fija

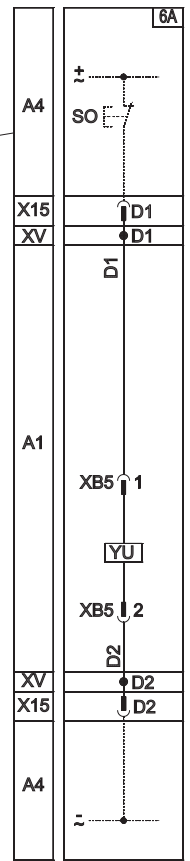

6

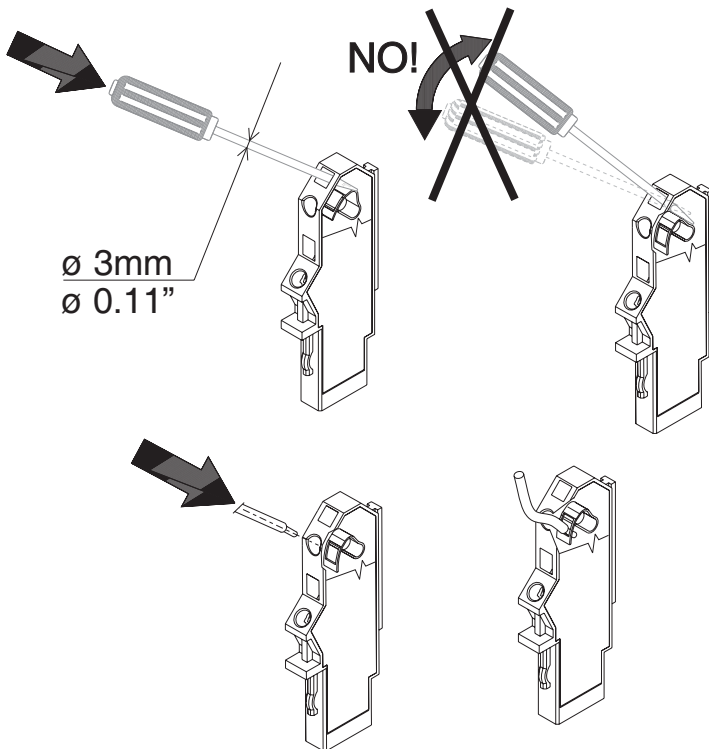

OPZIONALE ! DATI DEI CABLAGGI RIPORTABILI A CURA DEL CLIENTE
 OPTIONAL ! WIRING DATA TO BE GIVEN BY CUSTOMER
 OPTIONAL - DIE DATEN DER VERDRAHTUNG KÖNNEN VOM KUNDEN VERMERKT WERDEN.
 OPTION ! INDICATION DES DONNÉES DES CABLAGES À LA CHARGE DU CLIENT
 OPCIONAL ! DATOS DE LOS CABLEADOS REALIZABLES POR CUENTA DEL CLIENTE

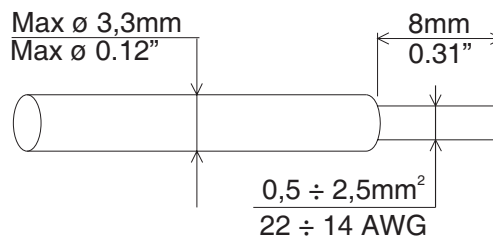

7

L'interruttore si può manovrare soltanto se il pulsante "PUSH BEFORE OPERATE" non è premuto, e cioè soltanto quando l'interruttore è in una di queste tre posizioni.

The circuit breaker can operate only when the "PUSH BEFORE OPERATE" button is not pressed, i.e. only when the CB is set to one of the following three positions.

Das Schalten des Leistungsschalters ist nur dann möglich, wenn die Taste "PUSH BEFORE OPERATE" nicht gedrückt ist, d.h. wenn sich der Leistungsschalter in einer dieser drei Stellungen befindet.

Le disjoncteur ne peut être manœuvré que si le bouton "PUSH BEFORE OPERATE" n'est pas enfoncé, c'est-à-dire uniquement quand le disjoncteur est dans l'une de ces trois positions.

El interruptor puede manipularse sólo si el botón "PUSH BEFORE OPERATE" no ha sido pulsado; es decir, sólo cuando el interruptor se encuentra en una de las siguientes tres posiciones.

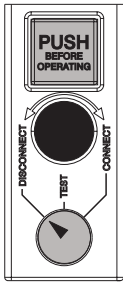
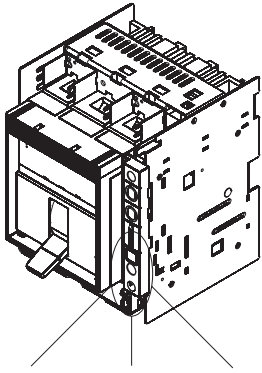

DISCONNECT

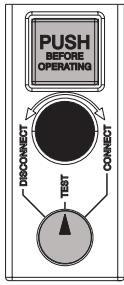

TEST

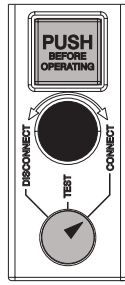

CONNECT

8

T7

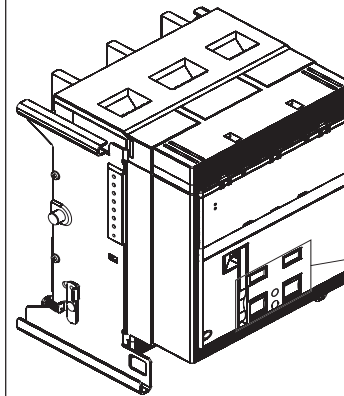
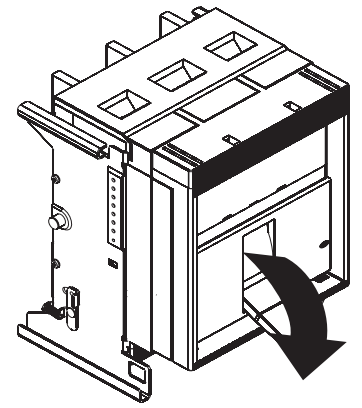

T7M

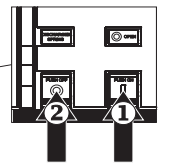

9

Posizione di partenza (estratto)
Starting position (disconnected)
Ausgangsstellung (Trennstellung)
Position de départ (débroché)
Posición de salida (extraído)

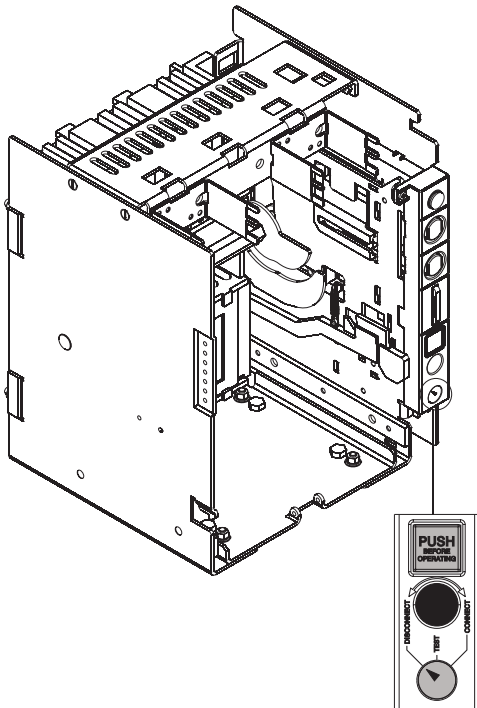

10

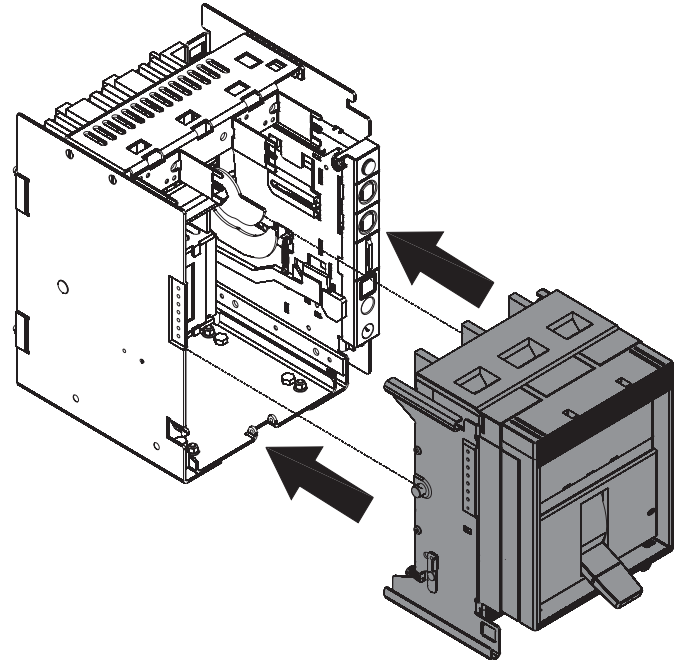

11

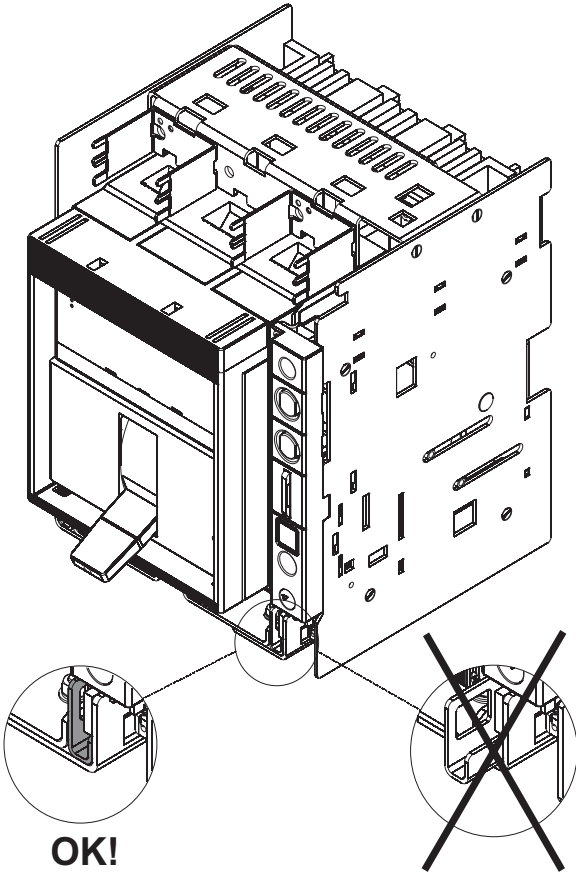

OK!

12

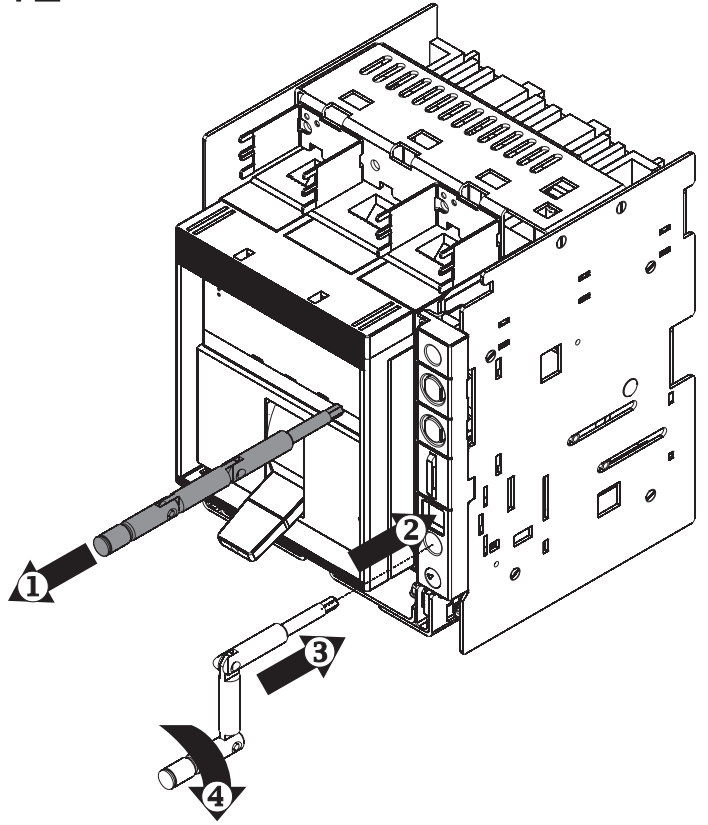

13

Posizione test
 Test position
 Prüfstellung
 Position de test
 Posición de prueba

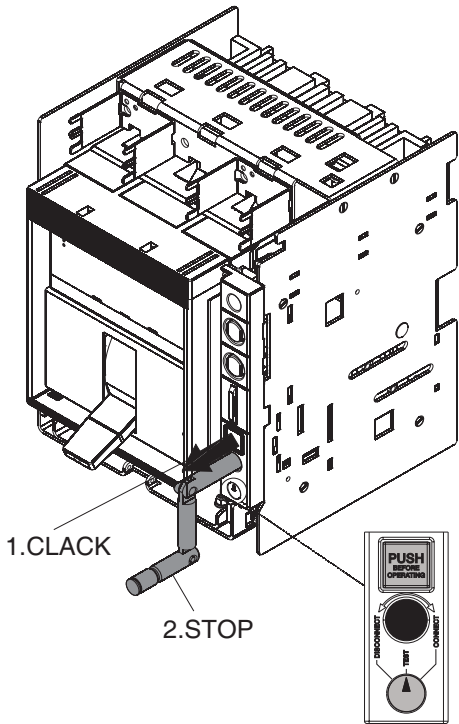

14

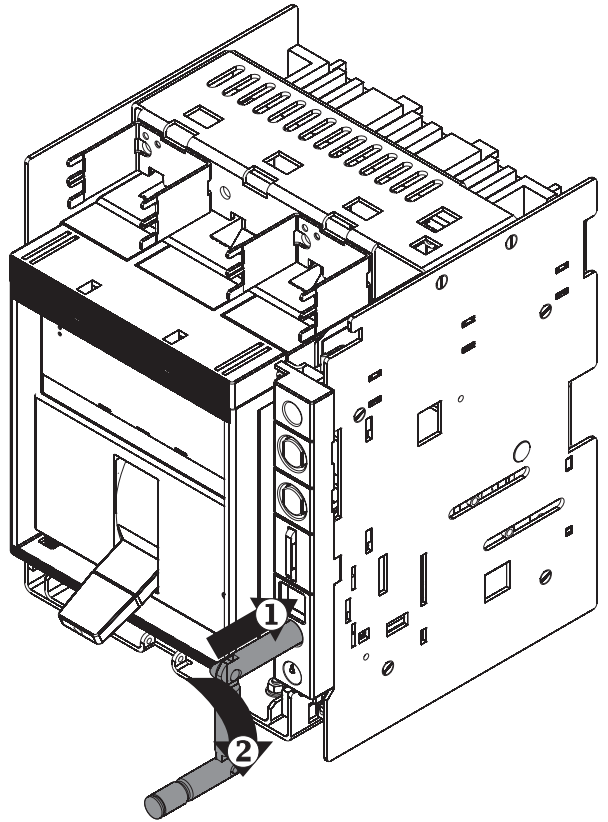

15

Posizione di inserito
 Connected
 Betriebsstellung
 Position embroché
 Posición de insertado

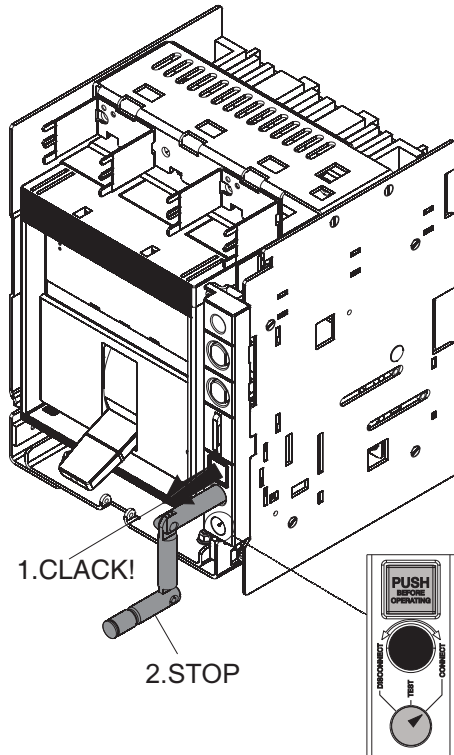

16

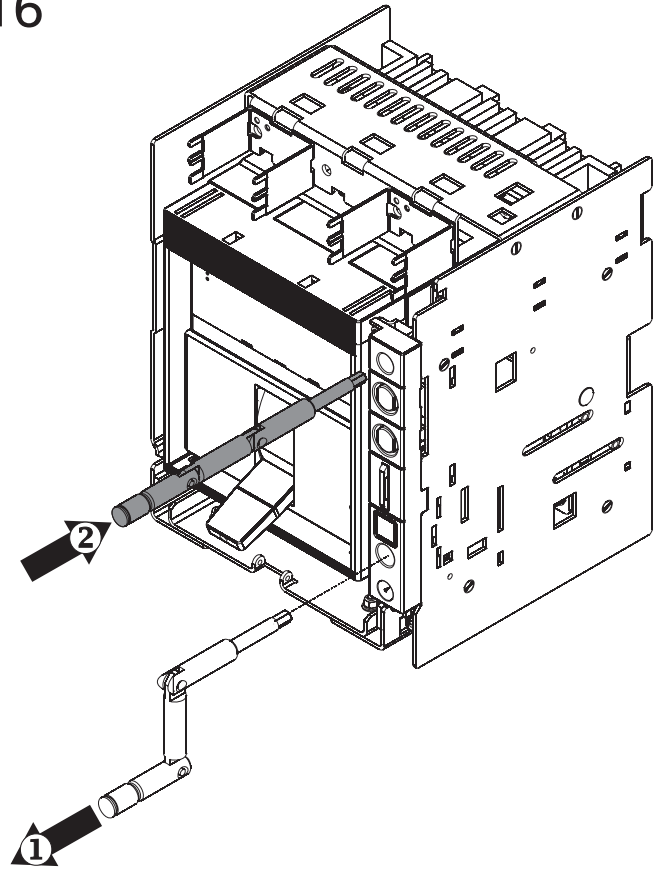

17

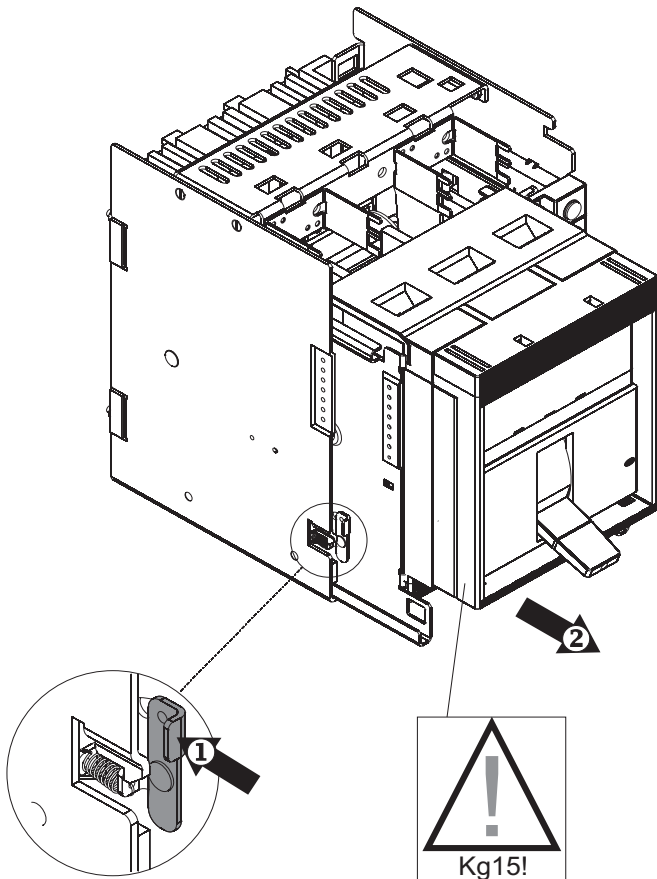

Per estrarre la parte mobile dalla parte fissa ripercorrere le operazioni descritte nelle fig. 12-16 in senso inverso. Al termine effettuare le due operazioni illustrate nella figura a lato.

To remove the moving part from fixed part, repeat the operations described in figures 12 to 16 in reverse order. When accomplished, perform the two operations shown in the figure.

Zum Herausnehmen des beweglichen Teils aus dem Unterteil die in den Abb. 12 - 16 gezeigten Vorgänge in der umgekehrten Reihenfolge ausführen. Zum Schluss die zwei in der nebenstehenden Abbildung gezeigten Vorgänge ausführen.

Pour débrocher la partie mobile de la partie fixe, refaire à l'inverse les opérations décrites sur les fig. 12 - 16. Pour finir, effectuer les deux opérations illustrées sur la figure ci-contre.

Para extraer la parte móvil de la parte fija, repetir -en sentido inverso- las operaciones que han sido descritas en las figs. 12-16. Al terminar, realizar las dos operaciones que se muestran en la figura puesta a un lado.

18

T7 W - RC

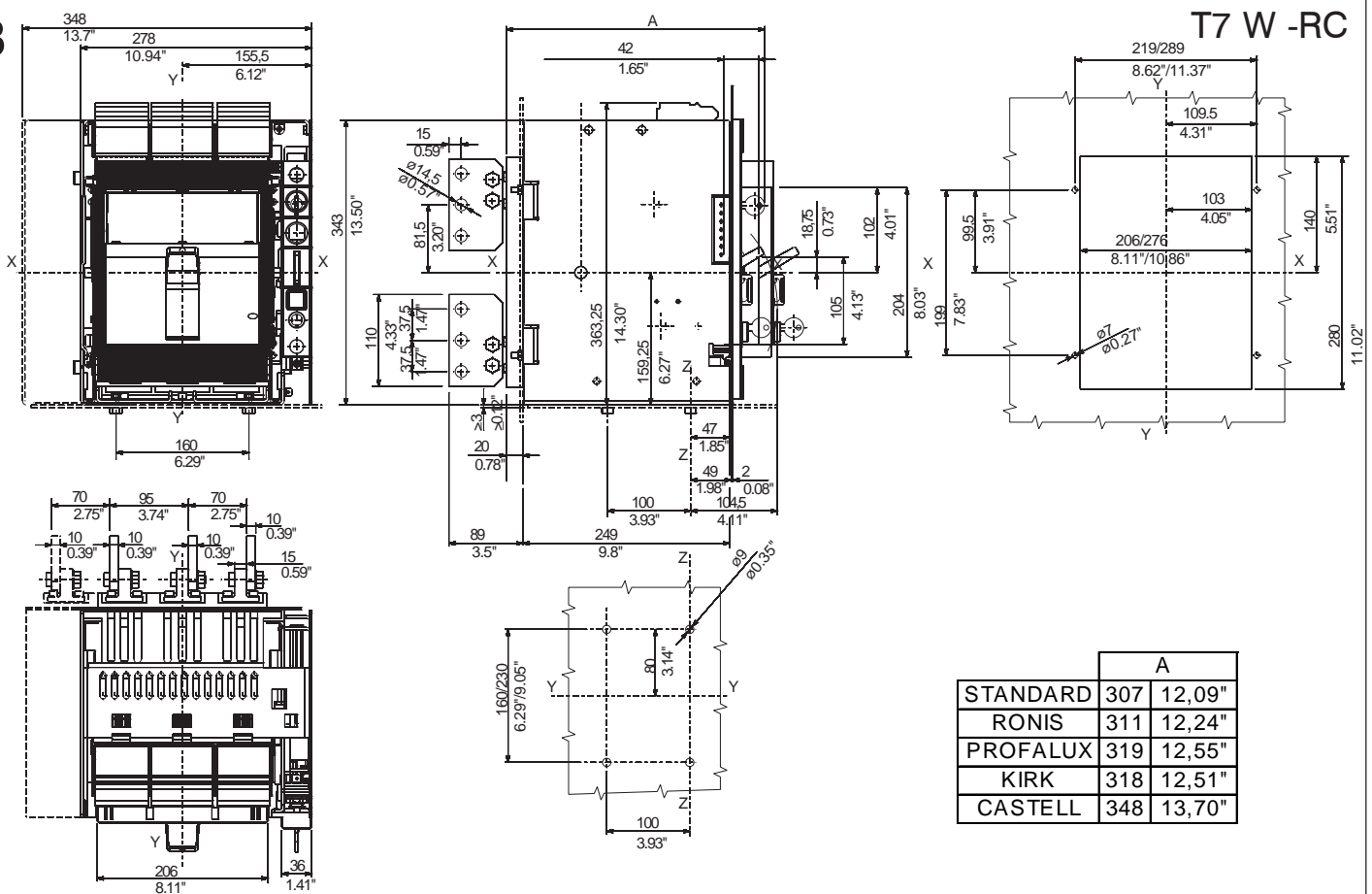

19

T7M W - RC

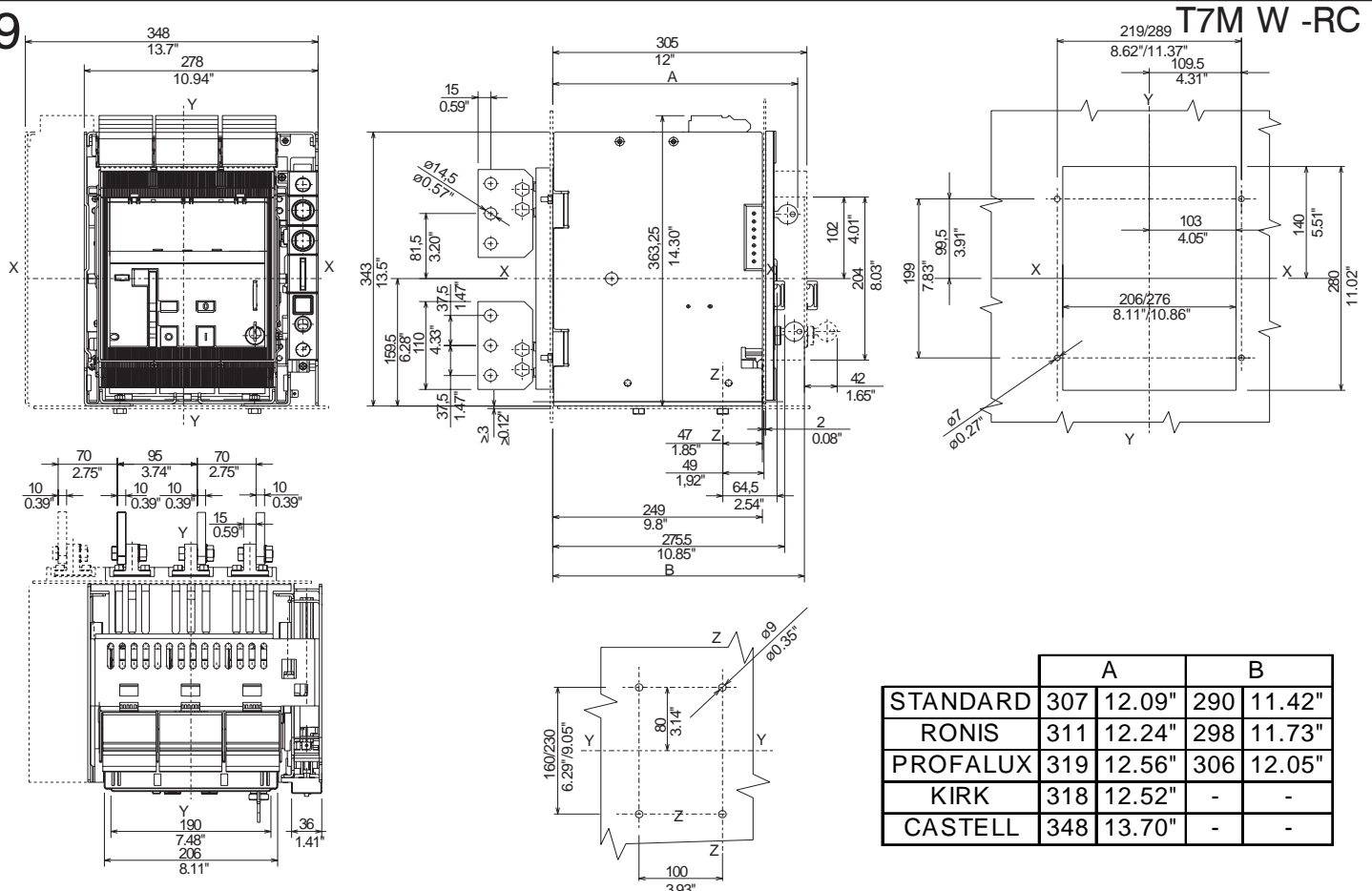

20

W-RC

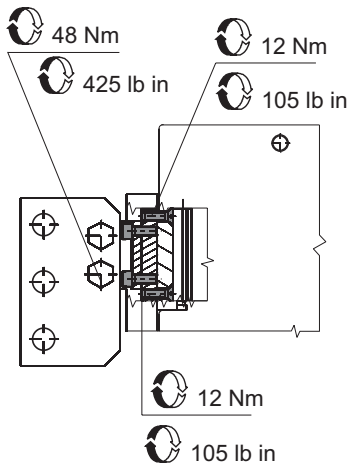

21

W

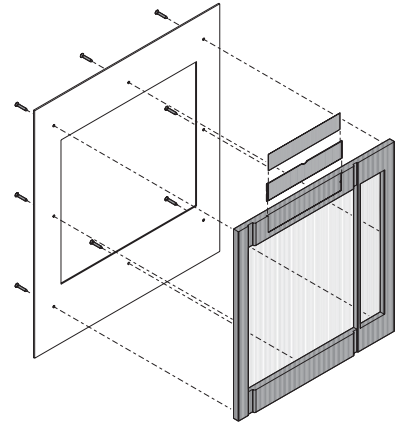
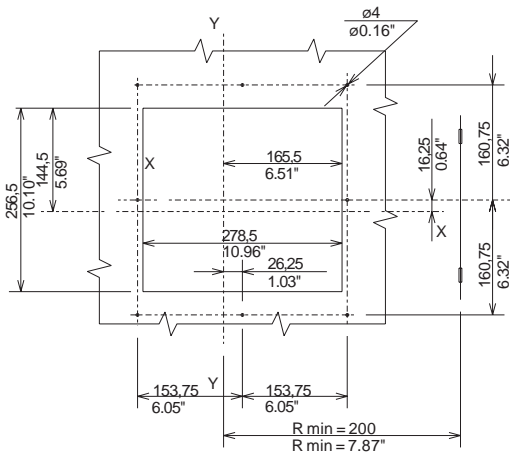

22

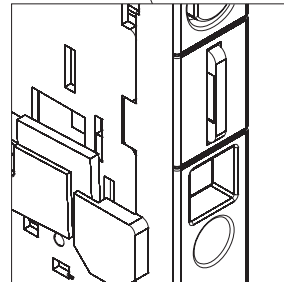
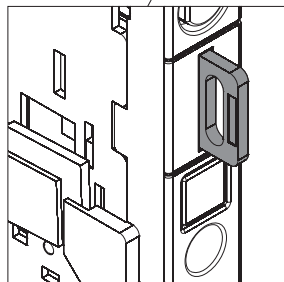
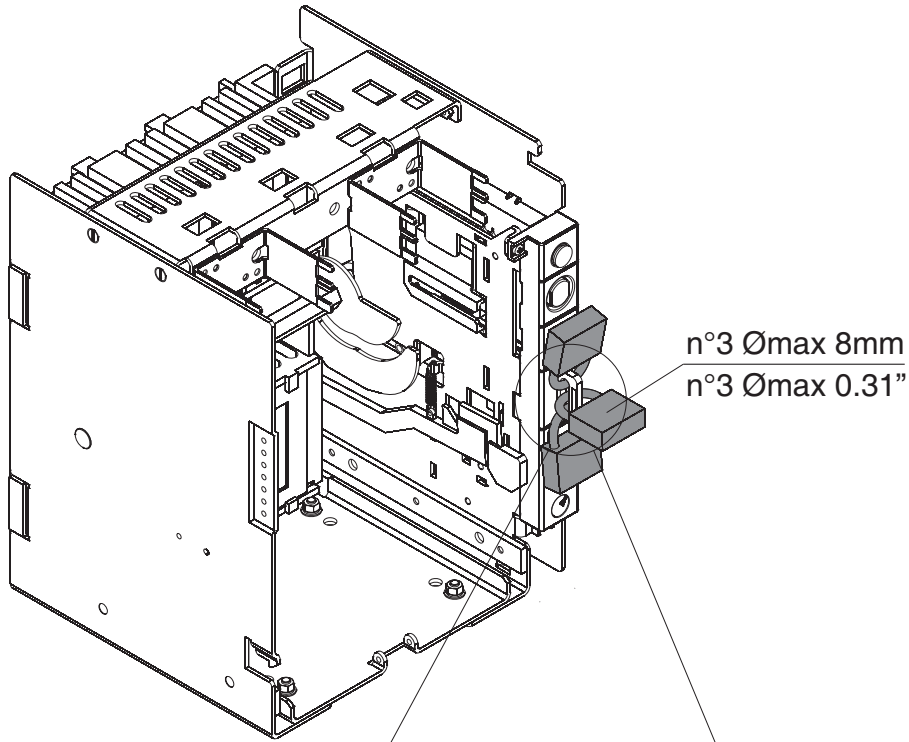

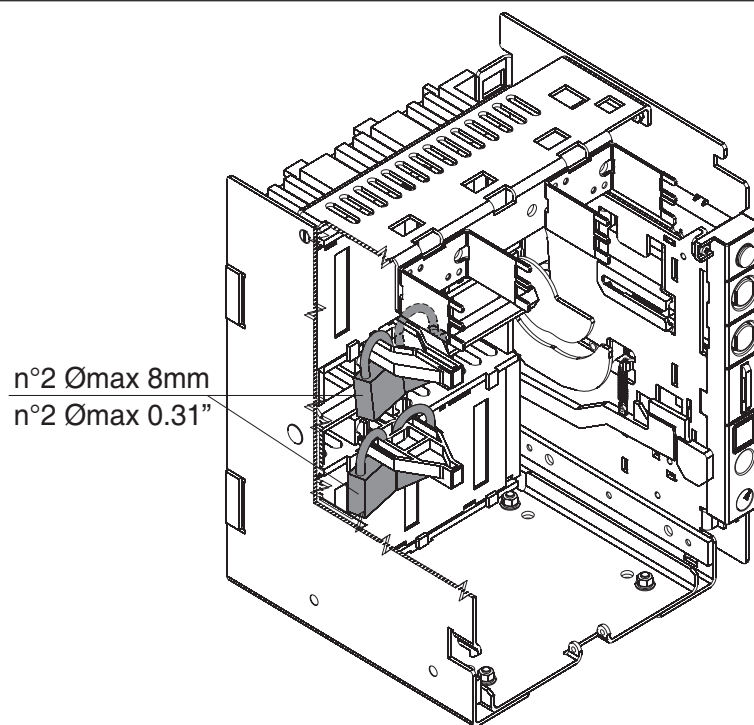

ABB S.p.a.
ABB SACE Division
Via Baioni, 35
24123 Bergamo Italy
Tel. +39 035 395.111 - Telefax +39 035 395.306-433

<http://www.abb.com>