

A publication of  
ABB Marine and Cranes  
ISSN 1894-1079

2014

# generations



generations profitability

## Profitability

Shipping at a watershed 6

New generation will unlock potential

Technology talk 12

With three technical experts from Lloyd's Register

In the zone 40

Interview with Andreas Sohlen-Pao

In this issue of *Generations* we explore three main keys to profitability – strategic decision-making, technical flexibility and operational efficiency – through the opinions of economists, lawyers, bankers and other decision-makers. We hope you find plenty of food for thought.

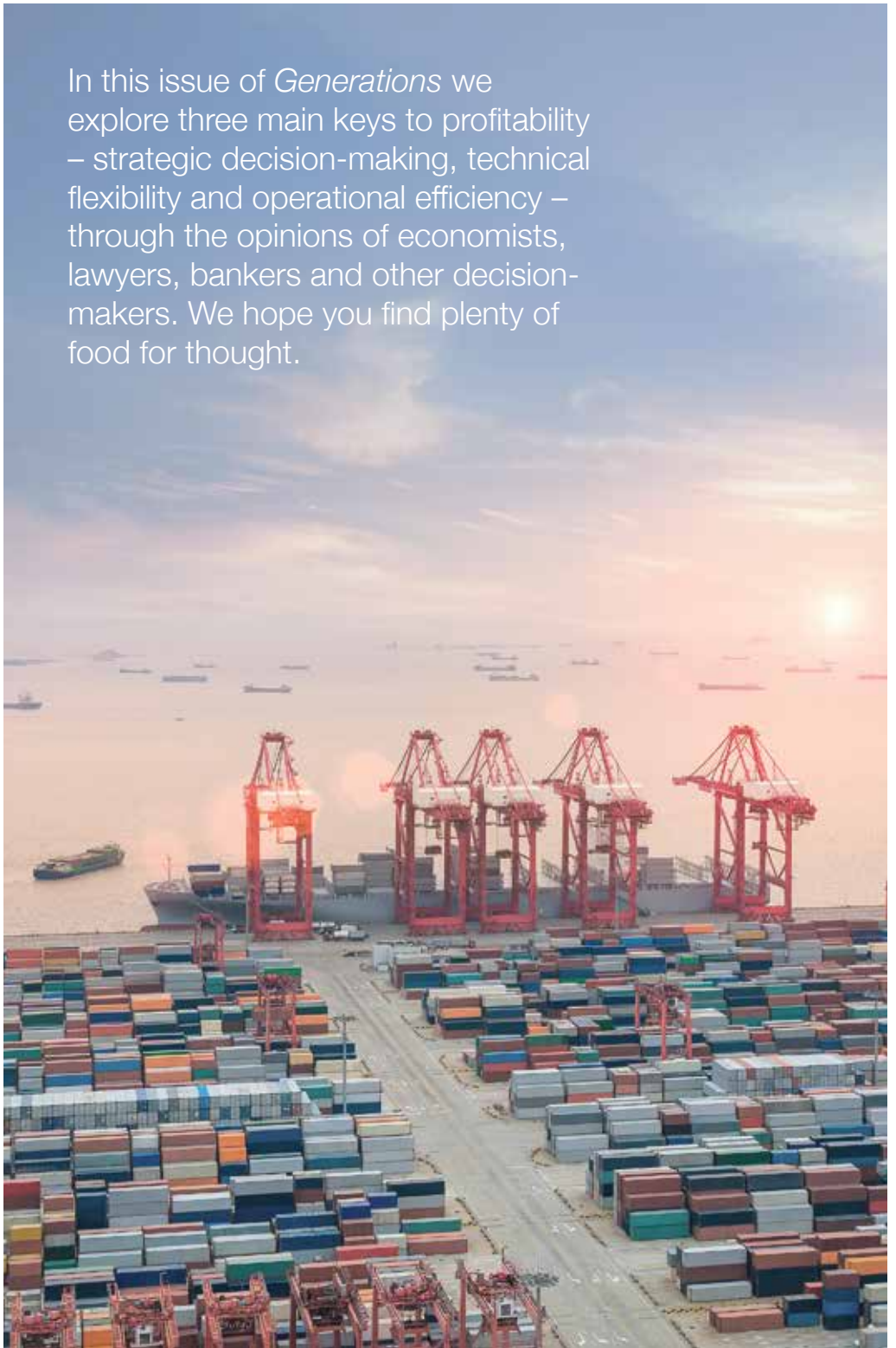

# Business insight

For a digital version of Generations, which includes extra video material, go to [www.abb.com/generations](http://www.abb.com/generations)

---

## 4 Opportunities and value

[Is your vessel an asset or a liability?](#)

---

## 6 Shipping at a watershed

[Maritime economist Martin Stopford's take on the industry](#)

---

## 10 Cargo owners needed to help lead change

[Stopford's thoughts on what should be done](#)

---

## 12 Technology talk

[The low-down from the technical heads at Lloyd's Register](#)

---

## 14 Flexibility could trump design point

[A more profitable way to design a ship?](#)

---

## 17 Where technology will take us

[The advances that lie in the future](#)

---

## 19 Risk assessment is the big issue today

[Emerging technology behind this trend](#)

---

## 22 Timing is all in shipping

[Ignore the cycles at your peril, says shipping strategist Peter Lorange](#)

---

## 24 Communication key to innovation

[Lorange gives innovators good advice](#)

---

## 27 Pressure cooker

[The demanding world of offshore drilling](#)

---

## 30 Texas style is catching

[What makes Houston's multinationals tick](#)

---

## 33 Taking the next step towards the Arctic dream

[Icebreakers forging ahead](#)

---

## 41 In the Zone

[Andreas Sohmen-Pao on staying profitable in a volatile industry](#)

---

---

## 44 Eleven years on site

[ABB project manager tells why they're still on site at Jurong](#)

---

## 46 Back to the future

[APM Terminals' Tiemen Meester on opting for automation](#)

---

## 49 Complexity that led to success

[The rapid growth of TC Buen's Colombian terminal has been four years in the making](#)

---

## 52 Entrepreneur with a vision

[The man behind the success of Amarcon's motion analysis software](#)

---

## 55 Sloshing worries many

[Why this problem won't go away](#)

---

## 57 Heavy lift getting heavier

[Hence the demand for motion analysis and monitoring products](#)

---

## 61 Sign on the dotted line

[Leading maritime lawyer on deals that can make or break a company](#)

---

## 63 Investors want proof of new technology

[It's a question of who will take the risk first](#)

---

## 64 Shipping moving at its own pace

[V.Ships CTO Andrea Zito shares his outlook on the shipping markets](#)

---

## 67 Remote monitoring link to fuel efficiency

[Research that could lead to 'self developing' tools](#)

---

## 68 Uncovering value

[How multi-million dollar systems are sold](#)

---

## 70 Real-time is too late

[A team of specialists looks at problems and possible solutions for container handling](#)

---

## 74 Price is not everything

[Export credit agency head tells technology providers to guide their customers](#)

---

# Opportunities and value

“What is a ship?” asked Dr. Helmut Sohmen, Chairman of BW Group, in a speech from 1985 titled “What bankers always wanted to know about shipping but were too afraid to ask.”

Sohmen ended the humorous address by saying nothing he had said was terribly novel, but he made some remarks that are relevant to this issue of *Generations*:

- “In financial terms, a ship is an asset when it is trading and a liability when it is idle.”
- “The financing of ships actually means not the financing of the hardware, but of the ship’s employment, both actual and potential.”
- “The more dedicated a ship is to a particular trade, the greater the difficulties of adjustment in a market downturn or in a changed situation.”

These statements point to flexibility and operational efficiency over a vessel’s lifetime as the keys to profitability, our theme for this issue.

So it is logical to assume that shipping markets should have excess capacity most of the time, and that high freight rates are the exception rather than the rule. As maritime economist Dr. Martin Stopford told us during the interview featured on pages 6 to 11,

market cycles are what help separate the successful shipowners from those who only pretend to be. The winners build both fleets and organizations that last, serving their customers in both good times and bad. They are simply better at managing their opportunities, beyond times where rates are good and everyone makes a profit.

Profit is “sales revenue minus cost” if we stick to the accounting definition of profit in its simplest form. Economic profit, however, is defined differently. It reflects the total opportunity costs (both explicit and implicit) of a venture to an investor.

A shipowner who looks at his opportunity cost before defining profit would be concerned about alternative technologies with payback through reduced voyage costs. He would also think of possible lost revenue when compared with a competitor who made a smarter choice.

His accountant would be happy as long as the ship was not operating “in the red”, while the economist

Is your ship an asset or a liability? That might be determined by your strategic decision making, technical flexibility and operational efficiency.

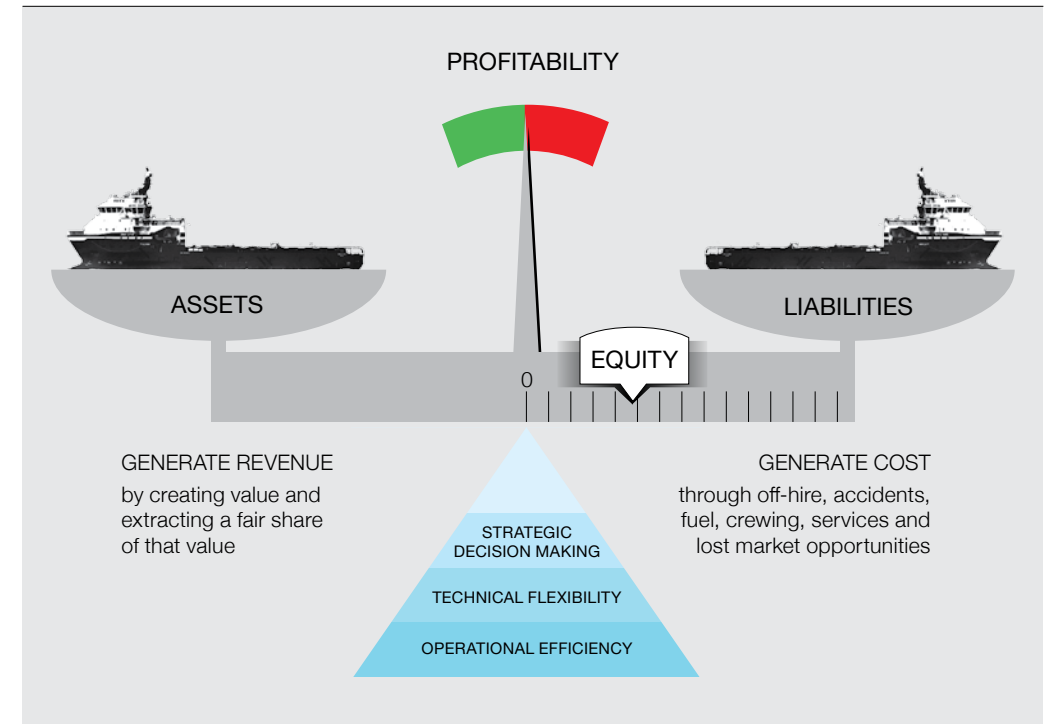

would advise him to look carefully at all the options before making a choice on how to make money. While still maintaining a profit margin, the marketing specialist takes a third approach: look for opportunities to increase the topline figures.

Harvard Business School professor Das Narayandas defines marketing as: “Create value and extract a fair part of it” in a book titled *Business Market Management: Understanding, Creating, and Delivering Value*, of which he is co-author.

One of the basic principles of marketing is expressed in the formula:

$$\text{Value} = \text{Perceived benefit} / \text{Price}$$

This puts price where it belongs: second to benefit – in the eyes of the customer. Benefit could come from increased reliability or convenience, or it could be a new freight product. But where is the benefit? Is it in the technology, hardware component, ship design, engine control or fleet deployment software? Or is it

## Opportunity cost

The *New Oxford American Dictionary* defines opportunity costs as “the loss of potential gain from other alternatives when one alternative is chosen”. So the economist asks: What else could I be doing with my money and assets?

in the performance of the overall logistics operation? That depends, of course, on the perspective of the decision-maker, since benefit is only of value when it is understood. “Perceived benefit” indicates that the value created depends heavily on how successful a business is in communicating the benefits of its products.

Text: **Johns Ensby**





# Shipping at a watershed

An industry-wide lack of technical knowledge is limiting the uptake of new technology in shipping, says Dr. Martin Stopford, author of the world-renowned textbook *Maritime Economics*. Now is the time to change this, he believes.

“The difficulty, of course, is making that change happen. It’s waiting for the evangelists to come along and push it in the right direction,” he tells *Generations* at the London headquarters of brokerage firm Clarksons, where he is president of the research department.

He suggests that because the majority of shipping’s current top managers studied finance rather than naval architecture or engineering, the technical trouble starts at the very top – at board level.

“It’s nobody’s fault, but for 30 years we’ve been running a business that is about buying assets and running them cheap. Principals are more likely to know how to do a bond offering than to deal with big data and the information a ship generates,” he says.

Stopford believes this basic lack of knowledge, or understanding of shipping technology, is behind the industry’s often dismissive attitude towards new ideas and why “there’s more technology in your pocket than on most ships.”

He thinks shipping should take inspiration from other industries to come off “auto-pilot” and move in a new direction. Citing the example of the Ford motor company, which “took its car model Focus apart and started again from the basics,” he says, “this takes a lot of people with a lot of technical depth.”

**New generation will unlock potential**



You've got to manage a lot of small components to get efficiency today.

"I don't know who in the maritime business has the capability, the budget and the resources to put that sort of thing together. What shipping needs is a Steve Jobs."

The late Apple CEO was a good example of how understanding the market, adapting technology and "sticking with an idea" can transform a company, says Stopford. Only with a new generation of tech-savvy decision makers will technology's potential begin to be explored.

"Shipping is an old-fashioned business," he continues. "We, who have grown up with it, may like it that way. Fortunately, there's a new generation out there that don't have the baggage we have."

"We need people at board level who understand technology and have the vision and authority to make it work at the very top of the company. It will take at least 10 years to breed a new generation of middle and senior management in shipping who really understand how to put all the pieces together."

"You've got to manage a lot of small components

## Martin Stopford

- Studied Politics, Philosophy and Economics at Oxford
- Doctorate in Economics from Birkbeck College, University of London
- Honorary doctorate from Solent University, Southampton
- Began his career in shipping in 1977 as Group Economist for British Shipbuilders, the public body which owned and ran Great Britain's shipbuilding sector
- Started lecturing at Cambridge Academy of Transport in the 70s
- Recruited by American bank Chase Manhattan in the late 80s as Global Shipping Economist
- Became MD of Clarksons Research in 1990
- Joined the board of Clarksons PLC in 2004
- Author of the textbook *Maritime Economics*, now in its third edition
- Awarded the Chojeong Book Prize for *Maritime Economics* in 2005
- Winner of the Lloyds List Lifetime Achievement Award in 2010
- Seatrade Personality of the Year 2013

to get efficiency today. That's something I think the average shipping company is really struggling with because many of them are quite small companies."

"I hate to say it, but I think this lack of technical depth is true of the shipbuilding business as well. They have been building roughly the same ship since 1985," he says. The evidence of this technological stagnation is "there in the numbers. The fuel efficiency of the ships, the basic design features have not changed much."

This lack of innovation and evolution in vessel design is, however, not true of the navigation, propulsion, cargo-handling and communications industries. Constantly developing often complex technical solutions to address upcoming operational or environmental challenges, these new systems expose the dearth of technical knowledge currently available across shipping companies.

### An act of faith

"The reality is that owners of shipping companies are often not very technical. They don't know what's possible, and if you're delivering an electronic engine

to them and the chief engineer can't work it, how do you escape from that conundrum?"

Stopford describes a situation where senior engineers are happy "as long as there's a sound coming out of the engine" because they are scared to touch the engine management systems for "fear of breaking them."

By reinstating technical competence and mixing it with forward-thinking management, a new generation of technologically literate shipping companies, "able to break the mould" could propel shipping into the 21st century. Stopford is convinced that those who can't or won't "reengineer" themselves are doomed. "They'll lock themselves into history and go the way of Research in Motion and Nokia."

"After 50 years of global free trade, the shipping industry is looking towards an era where it needs to pick up its bed and walk. It needs to do something different. Just carrying on building slightly bigger ships with each generation, and otherwise roughly doing what you did before, is running out of steam."

Stopford says shipping's stakeholders "don't have to be Steve Jobs" to understand that finding a new way of working, which enables them to use the "tidal wave of information technology" currently available, is essential.

"Anyone who has run a business knows it's not about figuring out what's happening. It's about getting a vision and putting one foot in front of the other. It's an act of faith. You don't really know until you get there whether you can do it."

Text: **Johns Ensby, David Hopkins and Helen Karlsen**

# Cargo owners needed to help lead change

Coupled with the dearth of technical know-how among owners, the need for cargo interests to become more closely involved in sea transport is “perhaps the greatest challenge of all” for the shipping industry today, says Dr. Martin Stopford.

**A** new era of collaboration between cargo and vessel owners could help transform shipping, he says, but cargo owners need to take the first step.

“It takes two to tango. If you want to run more efficient shipping, you need the cargo owners to step up and share the load,” he tells *Generations*.

---

Slowly, cargo owners are looking at the transport operation in a more serious way, because it is so much more expensive now.

Highlighting the last great era of “industrial shipping” – bulk shipping in the 50s and 60s and the oil majors’ tanker operations in the 70s – both, he notes, were driven by the cargo owners’ hands-on approach.

“The cargo owners built the ships, ran the ships, built the terminals, the cargo handling facilities and the coastal manufacturing plants and you ended up with a total logistics system, which was about as good as you can get. In many cases cargo interests led change by giving independent shipowners a long time-charter, enabling them to build bigger and more efficient ships. The owners thus became industrial shippers, not speculators.”

This totally integrated supply chain, perfected by the likes of oil company Shell in the 70s, has been largely relegated to history. “The seminal change of the last twenty years is the fact that the cargo owners have walked away from this close involvement with the transportation process and have left the independent owners to take, what has become, a greater risk.



## Deserves thinking about

“In today’s market, cargo owners sit on one side of the table, ship owners on the other, and the whole focus of the business is the next shipment.”

This major shift in emphasis over the past two decades, from the long term to the short and from lengthy time charters to a dependency on the spot market is, he says, “something that really deserves thinking about.”

Reservedly optimistic, in spite of the current “adversarial relationship between shipowners and cargo interests,” Stopford believes cargo and shipowners may soon have to become more cooperative, whether they like it or not.

Brazilian mining company Vale’s Valemax vessels are one example of the problems of a unilateral approach. The drivers going forward are rising fuel costs and environmental pressures, both of which could be addressed better by bringing cargo owners

back to the table as part of a long term approach to improving transport efficiency.

“With bunker fuel for an Aframax vessel now costing three or four times more than the ship, the economic model hasn’t changed but the value and importance of the components has.

“So slowly, cargo owners are looking at the transport operation in a more serious way, because it is so much more expensive now.”

Stopford believes that only with this cooperation from the charterers can the industry truly begin to re-examine how it operates. “Many of the things the industry needs to do could be much more effective with the cargo owners’ participation,” he says. “But managing that is, perhaps, the biggest challenge of all.”

Text: **David Hopkins**



# Technology

## talk

Three technical experts at Lloyd's Register Marine in London speak to *Generations* about risk assessment, future technologies, design point and more.



**Bernard Twomey**

Global head of electrotechnical systems, Global Technology Centre



**John Bradshaw**

Lead project engineer, engineering systems, Global Technology Centre



**Tim Kent**

Technical Director



### Lloyd's Register

- Established in 1760 as a marine classification society
- Multinational group operating in multiple sectors, such as shipping, oil and gas, power stations and railways
- Core business of Lloyd's Register Marine is classification but also a technical services provider
- Headquartered in London
- Owned by a charitable foundation, the Lloyd's Register Foundation
- Profits ploughed into research on new technology or engineering education
- Global Technology Centre (pictured here) with 400 employees located in Southampton



# Flexibility could trump design point

A new paradigm of ship design, using technical flexibility to optimize vessel performance, rather than a single “design point”, may result in “huge profitability” for owners, say the technical heads at Lloyd’s Register Marine.

**T**oday, ship designs are optimized around an estimate of normal conditions under which the vessel will operate, known as design point. But this does not necessarily represent the conditions the vessel will actually encounter.

“In that sense, it’s artificial,” says Tim Kent, technical director at Lloyd’s Register. “It’s a reference point used as part of the ship specification and contractual agreement between the owner and the builder. The ship has to achieve a performance level at this design point.”

Lloyd’s Register is working with at least one university to look at optimization throughout the design life of the ship, rather than around a single point. Kent calls this a “new paradigm for ship design.”

“Rather than optimizing around one point, technology could be applied to optimize the performance response as a flat plateau across the ship’s speed, sea or loading conditions. Couple this with

engineered flexibility within the system, to keep the overall consumption parameters within the optimum range, and there is a huge profitability opportunity.

## Makes more sense

“Then there’s a potentially different way of thinking about the design of the ship, its systems and how they’re controlled and operated. You’d need to think about how you were going to use the ship and integrate the conditions that the ship would see throughout its service life. Optimizing according to that, rather than against a theoretical point at which it’s going to spend very little time, makes more sense,” says Kent.

According to Bernard Twomey, global head of electronic systems at Lloyd’s Register, the concept of operations for the actual ship is considered alongside the emerging technologies. “What we’re finding is that flexibility, enabled through some new technologies, helps meet a range of business needs for a particular client,” he says.



A Lloyd’s Register surveyor checks machinery on board a vessel.

“Safety is a given but owners have a different perspective and set of requirements. It’s a challenge for Lloyd’s Register to understand those various operating modes. Are the systems going to be safe, dependable in all modes and, from a client’s perspective, are they going to meet their business needs?”

“This is an even bigger challenge for ships that are actually sold because it’s a fixed technology, but do the new owners understand the limitations of the technology? Again, will it meet their business needs?” asks Twomey.

Kent adds, “A ship is a very complex arrangement of structure, materials, mechanical and electrical and other systems. How these all interact is quite important to understand if you’re going to be able to control all of those system components together in a way to optimize the performance.

## Optimal speed for a business case

“The concept of operations is a fundamental part of that because it establishes the envelope under

“What we’re finding is that flexibility, enabled through some new technologies, helps meet a range of business needs for a particular client.”



The older part of Lloyd's Register head office at 71 Fenchurch Street, London

which that analysis is done. It's really important that everyone understands that, because taking the systems beyond the original design assumptions means you're taking them into the unknown in terms of their performance and interactions with others," says Kent.

He confirms that while there is no such thing as an optimal speed for a vessel, there is an optimal speed for a business case.

"If you can understand the ship costs, the capital expenditure, the depreciation and the operating expense, you can understand the voyage costs in the context of fuel and other consumables. Then, beyond that, there are commercial costs, like maintaining the cost of inventory in transit rather than getting it to the end destination and sold on.

"Maybe the incremental fuel cost of traveling faster to get goods to their destination faster makes more sense in the overall business case. But from an overall consumption perspective, if you can tolerate a longer inventory time, it reduces the voyage cost."

Kent says that if there is a need to operate at a slower design point, there will be a number of unintended consequences for the machinery operating at conditions it was not designed to operate at for a continuous period of time.

"Hence my suggestion that broader optimization might be something for shipping," he concludes. "It will be interesting to see how some of this research pans out."

Text: **Helen Karlsen**

Photos: **Lloyd's Register**

For more technical insight into design point, see page 146

# Where technology will take us

It's no secret that fuel efficiency will be a major driver of both profitability and maritime innovations in years to come. Here are some predictions about these technologies from Bernard Twomey, Tim Kent and John Bradshaw.

**A**ccording to the three, DC power systems are becoming more attractive and will continue to be so. "They tend to be on smaller vessels at the moment, but I can see this expanding into the much larger deep-sea going vessels," says Twomey.

"DC systems have been around for a long time but there hasn't been much uptake in the last 10 or 15 years. However, with the quest for more fuel efficiency, DC becomes very attractive. A lot of manufacturers are looking at DC."

But while there are significant benefits to DC, there is also a significant risk, warns Twomey.

"To put it bluntly, we don't have enough people within the industry with a sound understanding of DC systems. But there is a role there for manufacturers to provide that level of training on their systems. It's also a role for Lloyd's Register, to make sure the systems are fundamentally safe, so there has to be a partnership there."

## Multiple energy sources

"We're going to see multiple energy sources enabled by advances in the electrical technology that's

available on board," says Kent. "We will have the ability to harvest energy from all sorts of sources, even some solar power.

"There will never be entirely solar-powered ships. The ratios of available collector area and storage capability to the size of the ship, and the energy required to move it through the sea, just don't work. But there is absolutely an opportunity to harvest a significant amount of solar energy for a ship, provided you have the means to convert that energy and store it, such that it can then be converted into propulsion or auxiliary power."

## Battery technology

"As I said, we now have the ability to harvest energy, store it on board and reuse it later," says Kent. "But you can extend energy storage thoughts even further. I don't quite know where we'll get to with this, but the machinery space on a ship is very big. With significant advances in battery technology, you could stretch it to its limit. You could even envisage shore-powered ships that rapidly charge or swap out their battery power packs in high volume. Then you won't need an internal combustion engine for main propulsion. Not tomorrow, next year or next decade, but I think that at some stage in the future – who knows where the capability can take us?"



The sky is the limit with some of the new technologies

#### Remote monitoring and automation

“Whatever we put on board a ship in the future,” says Twomey, “you’ve got to look at it in terms of the way in which the seafarer is now trained to STCW (Standards of Training, Certification and Watchkeeping). I would say that the technology now being put on board the ship exceeds the educational requirements from STCW, so there’s a gap. I think there has to be a way of the manufacturers providing that, whether it is remotely or by looking at condition-based maintenance.”

Kent goes even further, saying: “Eventually, the technology will be beyond the reach of the crew; there will be a tipping point whereby all the operational assumptions need to be addressed at the design and build phase.”

“Automation and eventual autonomy will lead to manning and operating expense savings,” adds Kent.

“Things related to the structure that will drive down power requirements will be important,” says Kent. “So we will see lighter, different-shaped and smoother structures, different types of coatings, as well as optimization of the overall propeller-hull system interaction.”

“One of my areas is emissions and exhaust gas, which is fundamentally changing the shape of the industry. It’s driving alternative fuels like natural gas and methanol, and there are options like exhaust cleaning,” says Bradshaw.

#### Tailored solutions

He adds that one of the questions he gets asked a lot by clients is “What is the answer?” “Where I think the industry is entering a revolution, is that there is no answer, no silver bullet for fuel efficiency.

“It’s very much down to what your ship does and where it goes. The operators have to consider their own unique requirements and develop tailored solutions. That means there’ll probably be a significant degree of technology fragmentation.

“Oil isn’t going to go away and we’ll see natural gas, we’ll see methanol, all sorts of different technologies there.”

Text: **Helen Karlsen**  
Photos: **Lloyd’s Register**

For more technical insight into ABB’s DC technology, see pages 93 and 99

# Risk assessment is the big issue today

Risk assessment is a key challenge now facing the shipping industry, mainly due to the impact of emerging technology, say the technical trio at Lloyd’s Register Marine

In an industry that has been conditioned to “picking up a rule book or applying a standard,” this requires a “slightly different approach,” they add.

According to Tim Kent, “While there is no doubt that some new technologies, such as those associated with diesel electric propulsion, improve a vessel’s capability, we have had to adopt a far more risk-based approach to deal with the hazards associated with new technology and to explore how those risks can be managed. In the past, classification societies were seen as policemen within the industry, but now we’re more like enablers of innovation, keeping people on the side of compliance and environmental expectations, but helping them do it in a way that enables them to be successful with their solutions.”

“What we’re seeing,” he adds, “is that because so much is possible with new technology, the technologies are advancing more rapidly than we’re able to keep up with as an industry in terms of rules and regulations.

#### Requires top-notch engineers

“Of course, this is a risk in terms of the technology being cleanly and safely deployed. So we’ve had to adopt this risk-based approach to understand the hazards associated with new technology and how they can be managed,



Lloyd’s Register staff oversee the lifting of an Azipod into dock



“Everyone knows where they stand with the prescriptive rules. People can cost against them. But the challenge is to be more competitive within the industry and push the boundaries on performance without compromising on safety and environmental impact. This requires innovation, but ill-conceived innovation can be dangerous,” says Kent.

Kent adds that a risk-based approach requires top-notch engineers and people who are able to think more broadly about risk assessment. “Sometimes those are not actually the same people, so it means assembling a team,” he says.

“Properly verifying that innovation is safe and meets appropriate standards comes at a cost,” Kent adds. “It’s more expensive than picking up a rule book. No-one should be surprised about that because there are probably thousands of man-years worth of knowledge in the rules, so it’s not unreasonable to put a lot of time into ensuring innovation offers equivalent levels of dependability.”

According to Bernard Twomey, the level of technology integration now needed on board modern vessels also means the industry has to be more collaborative when assessing risk.

### Catch people out

“The field of electrical engineering is where we see more of the technological advances – but also more of the problems, in terms of system integration,” he says. “We do a lot of work with various companies and organizations and major universities around the world to help us understand the risks associated with some of the technologies we now find on board marine platforms.

“In the past, we’ve bought a number of components and have probably gotten away with the fact that these things will work and meet the business and technical needs. The problem is that the level of integration taking place now on a shared, modern platform can actually catch people out.

“People may think they understand how the interactions work, but we find that in certain cases one individual is not able to fully understand the interactions between all the technologies involved on a ship.

“So there has to be collaboration. Lloyd’s Register is very much a part of that, working with manufacturers, designers, shipyards. We also have to work with owners, because they have an expectation and we need to understand that and link it back to the operational side. Do we understand how the system is going to function under normal, abnormal and emergency conditions? These are the sort of things that are challenging the industry right now,” says Twomey.

### A model system

How exactly does Lloyd’s Register go about assessing risk for emerging technologies? The answer is through a systematic procedure based on the well-known life-cycle V model (see illustration on the right). John Bradshaw, who developed this procedure, explains the thinking behind it.

What we want to achieve is that the eventual operation of the vessel meets the original concept. So we want technology integration to take place on the left-hand side of the diagram, at the design phase, instead of at the build and commissioning phase on the right, as is traditionally the case.

The contract stage on the left – where the contract is placed with the shipyard – is where we already start getting into grey areas. The shipyard may start to fragment the contract because they’re not able to build all the equipment themselves.

They will be able to build the hull, but not the technologies that go into the hull, so a number of manufacturers around the world will be involved. In other words, the design happens at a sub-system level, whether it’s a propulsion system or an exhaust gas abatement system.

When the integration takes place on the top right hand side of the V model, this is where we tend to have problems. Changes that occur on the right side are going to have a significant financial impact, and you may end up with a ship that doesn’t meet the concept of operations for the ship owner – the worst situation you can get to.

### Robust approach

Everybody in the industry knows this model but the interesting part is what’s between the clouds. That’s

Life cycle V model

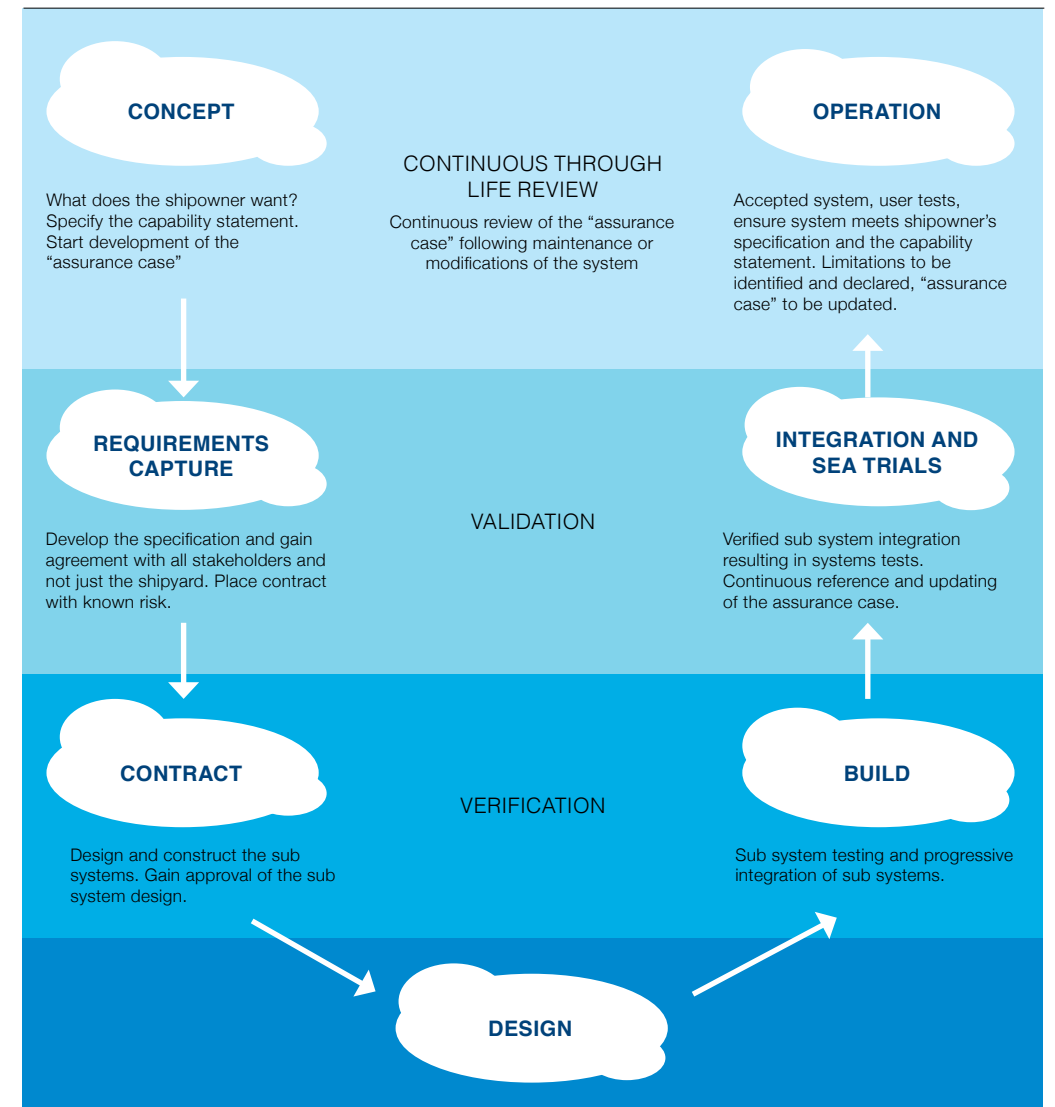

where we try to identify the risks. It’s about the development of an assurance case, reducing the risk to a tolerable level.

With this process, we’re challenging the traditional way of building a vessel and procuring equipment. But we’re already seeing a significant benefit from working with clients on the left-hand side of the model and throughout the life cycle process. At each stage there’s continuous validation, verification and reassessment.

So, the business manager will have some concept of operation other than ‘give me a ship that does whatever’. This kind of robust approach is a means of convincing the financial community that they’re going to get what they wanted to operate a business profitably. With this approach, there’s an advantage for early adopters of innovations because someone has invested sufficient time and effort in them.”

Text: **Helen Karlsen**  
Photo and image: **Lloyd’s Register**

# Timing is all in shipping

“Too often, business school students learn to make decisions in an ‘either/or’ or ‘positive/negative’ way. They often do not work actively with the constant up-down, in-out, long-short movements in business cycles. They do not learn to recognize critical turning points or understand the factors that make the difference between success and failure.”

**S**o says Peter Lorange, president and owner of the Lorange Institute of Business, which he bought four years ago with the aim of changing this trend.

“Those students then become real-world leaders, whose lack of understanding can lead to decisions and strategies that make the peaks and valleys of business cycles much more severe. Perhaps such a fallacy of linear thinking might most readily be seen in the ocean shipping business, where timing is all,” he says.

One of the corporate programs that the institute offers is a Shipping and Logistics Management specialization.

Lorange bought Zurich’s Graduate School of Business Administration at the age of 66, renaming it the Lorange Institute of Business. He had just retired from a 15-year stint as president of IMD, which he had pushed into the top rank of business schools.

This innovator in both the academic and shipping world, believes business schools have been too slow

to innovate “in terms of both the content of programs and courses and also the pedagogical process.”

## Critical importance of cycles

He feels these schools are to some extent responsible for the present economic crisis “because they did not sensitize managers to the critical importance of cycles in business.”

Lorange believes all businesses go up and down and that it is crucial in decision-making to have a better instinct for such turning points.

“It’s very useful to remember people like Mærsk McKinney Møller, who really spent time trying to understand the markets. His father built up the company based on an understanding of the markets and timing. He also developed that instinct very early on. He could handle several market scenarios and seldom made mistakes.”

Of the many powerful shipping personalities Lorange has worked with, McKinney Møller is the one he admires most. He is quick to tell you that: “I’m only one of five people, who were allowed to call him by his first name. And three of those were his daughters.”



Lorange Institute of Business in Zurich

“A guy like McKinney Møller was on the job all the time and was one of the richest people in the world. He worked very hard to understand those markets.”

Of his own success as the owner of a shipping company that specialized in platform supply ships for the offshore industry, he says: “I had a very detailed understanding of newbuildings relative to ships in the water and I updated that every week. When I saw that fraction of newbuildings had shot up, I sold the company.”

Lorange calls this “top-down” decision-making. Companies that fall into this decision-making group are under the umbrella of commodity shipping. Appreciate fast innovations

“These companies take a lot of advantage of business cycles. For them, it’s a matter of buying cheap and selling high, as we do with property. When you go in and when you go out is crucial, as is when you go long and when you go short.

“This is one extreme of the shipping industry. At the other extreme, there are industrial companies, which I call ‘bottom up’ organizations. They depend on much more involvement by many people.”

Lorange emphasizes that in “the real world” these two extremes are blurred but they are useful to separate in order to understand shipping cycles.

It is crucial in decision-making to have a better instinct for turning points.

This ‘bottom up’ niche appreciates innovation and long-term relationships and is more specialized. “These companies focus on tailor-made vessels for certain industries. For example, you have Wilhelmssen that deals with heavy equipment manufacturers or Oddfjell with chemical companies.

“These organizations are more interested in a steady supply of ships to maintain their market share. They buy vessels come hell or high water.”

“Of course,” says Lorange, “the industrial shippers need to pay attention to ordering new ships when the cycles are right. On the other hand, the market-related companies also need to pay attention to customers.” So, regardless of what business or segment you’re in, timing and cycles are everything.

Text: **Johns Ensby and Helen Karlsen**

# Communication key to innovation

Innovations in the shipping industry need to be communicated better to the relevant decision-makers, says shipping strategist and business academic Peter Lorange.

Speaking at the Lorange Institute of Business in Zurich, of which he is owner and president, he tells *Generations* that it is worth looking at the “basic treatment of innovations.”

The author of *Shipping Strategy - Innovating for Success*, Lorange says, “It’s important to understand who your target group is – in this case, the shipowner.” He adds that while “owner” is a broad category, investors in shipping companies and vessels can also be regarded as owners.

“These owners basically ask one question: How can I come up with more competitive ships? And more competitive today means more fuel-efficient. Five years ago, it would have been higher speed and ten years ago, safer ships.”

So, how does an equipment manufacturer communicate a fuel-saving innovation to an owner? According to Lorange, winners in the market place tend to have a larger focus on their customers’ needs than on the beauty of their own solutions.

“Many of the equipment suppliers who should be driving innovation like to talk to their counterparts

within the shipowning organizations. So they talk technical to technical.

“They may want to talk about the technical features of such-and-such a gadget, instead of telling the shipowner what really matters: how much fuel the gadget will help to save.”

## One-to-one communication better

Lorange, who ran his own shipping company for 19 years, says, “I’m not so sure that these things are well communicated via technical fact sheets either, which is one-to-many communication. That’s not what decision-makers read. One-to-one discussions and communication via the internet work much better,” he says.

On the age-old problem of resistance to new ideas, Lorange says, “It’s important to understand there will always be a certain hesitance to go for new things but, again, if people become convinced there is a pay-off, they will do it.”

Another dimension to this resistance, he says, is that “shipyards make money out of long, relatively standardized series. So, for them it could be bad news to change a long series into a shorter one.



## Peter Lorange

- President and owner of the Lorange Institute of Business in Zurich (former GSBA)
- Previously President of the International Institute for Management Development (IMD) in Lausanne and the BI Norwegian Business School
- Taught at the Wharton School, University of Pennsylvania and at the MIT Sloan School of Management
- Received his undergraduate education from the Norwegian School of Economics
- Awarded an MA in operations management from Yale University and Doctor of Business Administration from Harvard University
- Holds six honorary doctorates
- Owned and ran S. Ugelstad Rederi shipping company for 19 years

## Why he went into shipping ...

“I am basically an academic. I have written 21 books and more than 130 articles, I have six honorary doctorates. But I asked myself: ‘Why should I talk about business like a sociologist and not do business like an anthropologist?’ One of the things I ended up thinking about was shipping. So I inherited part of this little shipping company in 1988 and subsequently bought more and built it up. It turned out great. It was great to have to deal with cycles and innovations within this shipping reality. I sold it in 2007 and did very well. Now I’m heavily into shipping in that I buy shares in ships.”

In 2007 Lorange sold the Norwegian offshore services shipping company, S. Ugelstads Rederi, to Athens-based Aries Group for a reported €90.4 million (at March 2010 prices)

“So, for instance, we have studied shipyards who say ‘great innovation, great ideas’ but they proceed to give you basically an old design with a bit of cosmetics here and there.

“The business cycle makes it difficult to have steady innovation. It’s only when the cycles are down that

there seems to be an eager acceptance for innovation.” Right now the market is ripe for innovation.

“If you talk economic cycles in general, things are going slightly better. If you look at shipping cycles, things are certainly close to the bottom,” says Lorange.



“The shipping industry has been relatively conservative up to now, but over the last few years there have been dramatic innovations. All of this started with the need for more environmentally friendly and fuel-efficient ships.

“It’s extremely important for anyone thinking about ordering new ships today to make sure they are highly energy and cost efficient. I don’t see how you can sell old equipment today.”

But why buy new ships in an already over-supplied market?

Older ships may be technically sound but economically obsolete, says Lorange. He cites the example of bulk carrier fleets, where “the optimization of the entire fleet benefits from the more variable speed flexibility features of the new modern ecoships.”

“If you are a container liner and you compete in the so-called East-West trades, you’ve got to have the latest big, fuel-efficient ships. They also have to have a variable speed so that they arrive on time.

“Maersk, for instance, discontinued its daily service between China and Europe because of the technology issue. You simply have to have the latest ships out there. That’s what your customers expect. The same is true for cruise lines.”

---

It is only when the cycles are down that there seems to be an eager acceptance for innovation.

The speed of innovation is “everything today”, says Lorange. And it is the big customers of shipping companies who appreciate these fast innovations.

“Companies like Nestlé, Adidas, Unilever take fast innovations as a given because this is what they give their customers. Automotive and other manufacturers are also under heavy innovative pressure. Why shouldn’t they require the same from their suppliers?”

But, while developers may have the best, most innovative technology going, Lorange’s message is that this is not enough. “It has to be seen by the decision-maker and it has to be seen as relevant,” says Lorange.

He sums up the innovation process as one moving from customer needs to innovation to communication.

Part of the communication process is branding. Having a big brand name behind one’s innovation is a huge advantage in getting it onto the market, says Lorange. “Innovation means, by definition, something new. It means buyers take a certain risk, but if you have a big brand name behind you, that risk is easier to bear.”

But, as he says, “Innovations should be communicated to the relevant decision-makers.”

Text: **Johns Ensby and Helen Karlsen**

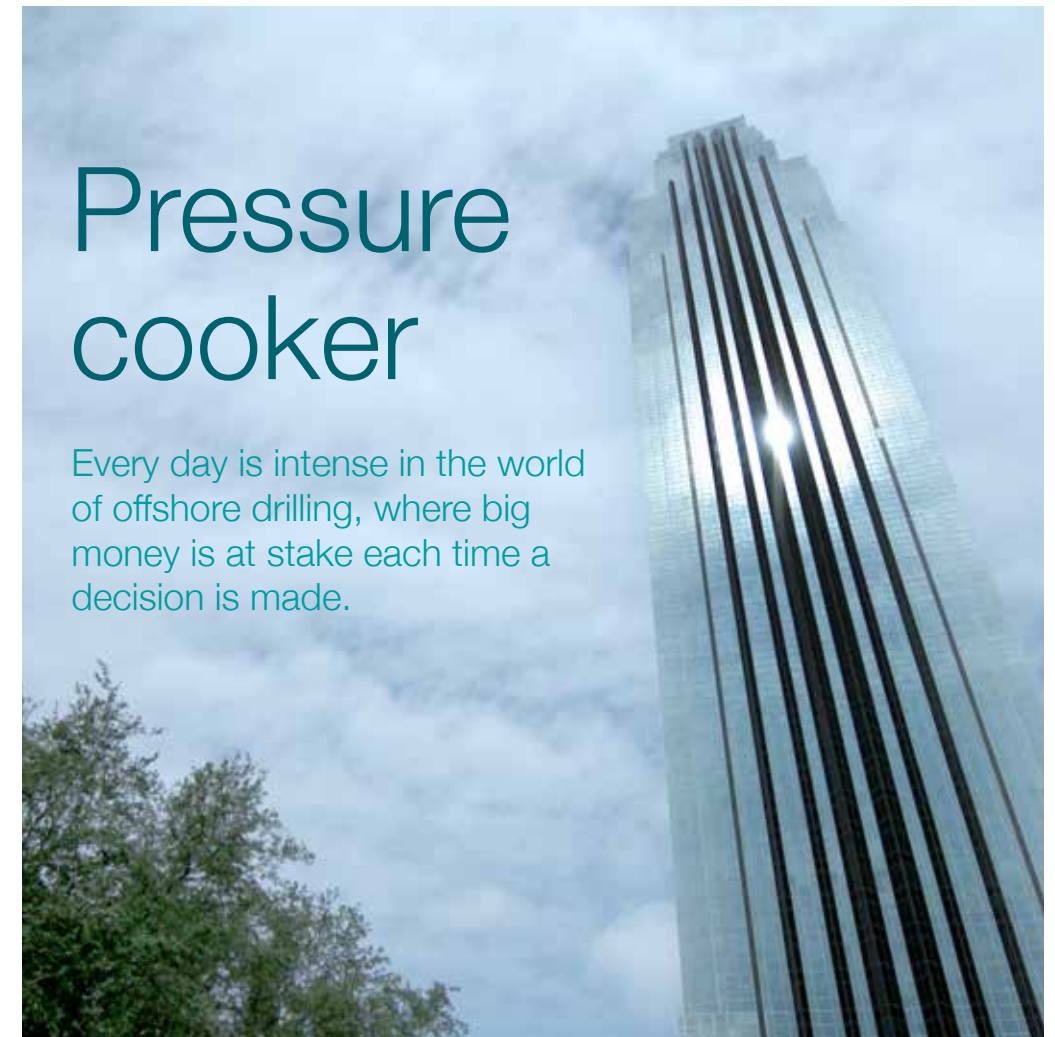

Rowan Companies’ headquarters in Houston, Texas

This is something that Rowan Companies Vice President of Project Management Jason Montegut can tell you about. Responsible for new builds and upgrades, he’s just delivered the company’s first drillship and is watching over three others still at the shipyard, in addition to the existing fleet’s upgrade and repair work.

Behind all of his decisions is the awareness that every hour a rig is out of service hits the bottom line. The risk of downtime is a major factor when considering the introduction of new technology, equipment or assets.

“Our costs on a daily basis are high, and that 24-hour period of being down or out of service is costly to the company,” he says. “And that’s only a fraction of what it costs our ultimate customers, the oil companies.” He continues, “You’re almost going through the fog every day, not knowing what’s around the corner. You plan for what you know, you mitigate the risks that you can only anticipate, and then every day you wake up and see what’s on your plate.”

Montegut says that it’s how a project is approached, planned and executed that determines its success and, ultimately, its profitability.



Jason Montegut

The four new drillships – Rowan’s entry into the deep-water market – are a massive investment. While the high daily rates currently enjoyed by rigs could offset this cost, they are not guaranteed. Given the uncertainty, how are decisions made with so much money at stake?

### The process

Rowan’s process is systematic, regardless of whether it involves an upgrade or a new build.

“We evaluate our return over the lifetime of the asset, taking a blended rate into consideration,” says Montegut.

Supporting the process is a central decision-making tool – the corporate risk register, which is a log of identified risks, their severity and the actions to be taken.

“Through various studies and analyses, we identify what our risks are and how to best mitigate them. Those are things like the technological advances and equipment that can help aid us react to events more quickly, possibly even to avoid those events in the first place.”

Rowan’s approach has been to design its own vessels, focusing on the high-specification end and incorporating advances and technologies that reduce downtime. “As a result, we deliver an asset at a decent cost but a good rate of return for the life of the vessel,” he says.

One of those advantages is ABB’s new advanced power system featuring technologies such as the diesel generator monitoring system (DGMS) integrated into the power distribution fast protection and communication system. This in combination with the 3-bus 6-split design provides important advantages both in reduced downtime and ease of system maintenance. This combination has been used for the first time on Rowan’s dynamically positioned drillships.

Montegut explains that the goal behind the decision to use these new technologies is high uptime and maintaining the operability of Rowan equipment. “The design of our entire power distribution system is geared to having redundancies in place so that we can realize a continuous in-service period,” he says. “And what ABB has been able to provide us with are the tools that allow us to do that.”

Rowan was already familiar with parts of the technology used by the DGMS. “We felt that the next logical step was to add some more redundancy to our power management system,” says Montegut. “We had done our due diligence in all the failure analysis with ABB to identify where those risks were, and we felt it was best to put it on that first ship. The sea trials went really well. We had no issues, the system performed as it should have.”

“This is calculated risk – it’s understanding that there’s risk, but mitigating to the point where we could head any kind of issues off before we experienced them.” Rowan now uses the ABB power system on a second drillship, Rowan Resolute.

He says that a factor of the success of using these new technologies is the company’s way of working as one team with its supplier, ABB, and the other stakeholders in its newbuild program, including customers. “This was actually a risk-mitigating factor,” he says. “We’re either going to succeed or fail together, and it just makes sense. Now, that’s true across the board for all of our projects, not just with power distribution technology.”

### Making a profit

Making a profit in the high-pressure offshore drilling environment is not a riddle to Montegut, who has his own recipe:

In addition to the all-important focus on minimizing downtime, he points to several other factors, not least, focusing on customers. “If you have a happy client, it’s easier meet your goals and make a profit because you can continue working your plan,” he explains. Competent people, the equipment used and having redundancies in place are also critical factors.

Montegut rounds off by emphasizing again that planning is vital. “That’s the core of what we are doing.” But it’s the things that can’t be planned for that keep him up at night, he says with a smile.

Text: Jennifer Varino



## Rowan Companies

- Founded in 1923
- Headquarters in Houston, Texas
- Offices in Aberdeen, Kuala Lumpur and Al-Khobar, Saudi Arabia
- Listed on the New York Stock Exchange as RDC
- Mission to be the most efficient and capable provider of demanding contract drilling services
- Sold manufacturing and land drilling business in 2011 to focus on offshore
- Entered deepwater in 2013
- Owns four state-of-the-art drillships – the Rowan Renaissance was delivered in the first quarter of 2014 and is now in operation and the remaining three will deliver at regular intervals from 2014 to 2015
- Has 30 jack-up rigs in operation at different sites around the world

# Texas style is catching

## Is the go-for-broke “wildcatter” way of thinking still behind today’s Houston-based energy multinationals?

Home to more than 5,000 energy-related firms, Houston is often called the energy capital of the world, a label locals are happy to claim. Indeed, the energy industry is a driving force in the city’s massive economy.

Many of the industry’s multinational corporations located there also have the city as their global headquarters. Rowan Companies is one of them. Generations asked Vice President -- Projects Jason Montegut whether the local culture contributes to the company’s willingness to take risks.

“Texas does have a bit of that wildcat, be-first-out there-and-get-it-done, attitude, and Rowan, in a way, emulates that,” says Montegut. “Some of the most knowledgeable drilling people, and I can say risk takers, are here.”

While he acknowledges that a “wildcat” style can have a bit of a negative connotation, he explains that Rowan’s interpretation of it is to take carefully calculated risks.

“There are times we need to get out there and help lead the way, but we do so when we’re comfortable, and that’s certainly passed down through the organization,” says Montegut.

### What is a wildcatter?

A person who drills wildcat wells, which are exploration oil wells drilled in areas not known to be oil fields. A famous successful wildcatter was Texan oil tycoon Glenn McCarthy. The term’s origin comes from Pennsylvania’s Wildcat Hollow, one of the many productive fields in the early oil era. According to tradition, a speculator who risked his luck by drilling in this narrow valley shot a wildcat, had it stuffed and set it atop his derrick. Because the area was largely untested, the term wildcatter was coined, describing a person who risked drilling in an unproven area.

Source: Wikipedia

“Rowan, back in the day, took a land package and put it on some legs and actually created the first jack-up drilling rig,” he says. “Rowan has a history of being out in the front, taking those calculated risks.”

He points to several other instances as evidence of this at the company – the high-pressure, high-temperature (HPHT) wells they drill and a jack-up with the world’s first 20,000 psi blowout preventer (BOP), which is now 25,000 – again a world first.

### How Houston became the energy capital

After World War II, Houston developed one of the two largest petrochemical concentrations in the United States, thanks to nearby coastal deposits of salt, sulfur, and natural gas, which were used heavily during the war due to US government contracts. By 1990, around 250 interconnected refineries spread from Corpus Christi, Texas along the coast to the Louisiana border. As a result, the Port of Houston’s main exports and imports were petroleum and petroleum-related products.

Source: Texas State Historical Association

Montegut joined Rowan in 2011 as part of the establishment of a deepwater department at the company. He remembers that the questions he was asked in its early phase were not about making cuts or eliminating anything in this new area. Instead, he heard: Are we doing everything we can? Are we looking a few years down the road? What are the technologies going to be like then?

He links this type of careful probing back to the Texas culture. “That’s what we have in Houston, especially being the energy center. It’s either you do that or someone else will, and people understand that, which makes it exciting. There’s certainly nothing mundane about this industry or the city, for that matter.”

Earlier in his career, Montegut worked for other Texas-headquartered drilling contractors in Indonesia, Korea and Singapore. He feels that the Texas influence remained at the top level of the companies but that it was at times a different story on the ground in some of the foreign countries as a result of slow communication partially diluting the can-do style. He says, “When I first started, we still used carbon paper and had Telexes. E-mail was so slow you’d click the button and then leave the office for the evening while it downloaded.”

He adds, “Nowadays, everything is so global. It’s instantaneous – you can video conference with anybody around the world at any time, and so I think it’s easier to convey that attitude.”

But a lot depends on the company says Montegut. “There are a lot of companies that just get so big, it’s hard to really maintain that can-do attitude and still, at the same time, manage a massive group of culturally diverse and dispersed people.”

Rowan has been able to keep it small enough and keep in touch with senior management well enough to where you don’t have that dilution,” he explains. The company’s relationship to risk is key to maintaining its profitability and returning the most back to shareholders, according to Montegut.

“By highlighting and addressing risk up front, we’re able to take advantage of technology – we’re very in tune with what the advances are and are quick to respond and to act on that. While we’re not typically the first one to jump out there, we follow very closely.” Although he feels that the oil industry can be similar around the world, Montegut recognizes the importance of respecting the culture of the host country. He says, “It’s about meshing the various cultures, bringing a westernized type of culture into a lot of countries that, frankly, haven’t seen this kind of expansion or technology. It’s caring about the environment and about the people and the overriding theme of keeping everybody safe – that crosses all borders and boundaries.”

Text: Jennifer Varino





## Next steps towards the Arctic dream

The goal of year-round traffic through the Arctic is now one step closer with the advent of the biggest, most powerful ice-breaking LNG carrier. Innovations like this are just the start of an Arctic technology revolution set to ripple throughout the wider shipping industry.

**A**s the global search for natural resources and new sea routes continues, the brightest minds are focused on the Arctic. The remoteness and harsh conditions at this last, frozen frontier, coupled with its fragile environment, pose unique engineering and other challenges.

Mikko Niini, senior management advisor at Finland-based Aker Arctic Technology, which designed the new ice-breaking LNG carriers, says that for regular Arctic shipping to be viable, economies of scale are essential, “meaning the size of vessels operating there must increase.”

The first of the 16 new ice-breaking tankers is due to be commissioned in South Korea in 2016. The 16 vessels are being built for the Yamal project, which will see LNG transported from the Yamal peninsula in northwest Siberia to Europe and Asia. The contract includes an option to equip a further 15 vessels.

The Azipod® propulsion units that will power the 170,000 cubic meter LNG carriers will have a total output of 45 megawatts. The vessels will be built with ice strengthening of ARC 7 category along an ice class scale that goes up to 9.

According to Niini, the new vessels are just the start of further penetration into the Arctic. “Looking at going east of the Taymyr peninsula or through the Northwest Passage is the next step. So we need to move step-by-step into the unknown. Not only are we talking larger vessels and more powerful propulsion units, but harder ice calls for new dimensioning principles, maybe even new materials.”

#### Step-by-step approach

Knut Ørbeck-Nilssen, president at DNV GL Maritime, agrees with this step-by-step approach. In a recent article on the company’s website – titled “Can Arctic risk be managed?” – he writes: “Some areas, such as the southern part of the Barents Sea, can be considered very similar to the North Sea with respect to climate conditions. But, in contrast, the east coast of Greenland is a far more remote and difficult area for offshore operations.”

Challenges in one area may not be an issue in others, and technologies and procedures suitable to one region may not suit others, says Ørbeck-Nilssen. “The industry will benefit from starting exploration in areas where conditions are not so different from those we are used to. We should not move to the more unexplored areas before improved technology

## The Arctic region

- Situated north of the Arctic Circle, the region includes the Arctic Ocean and parts of Greenland, Canada, Russia, the United States, Norway, Sweden, Finland and Iceland.
- It is thought that 13 percent of the world’s remaining oil and 30 percent of its gas exists here.
- The Arctic Ocean has a 45,000-kilometer shoreline.
- Its deep seabed may be rich in manganese and other minerals.
- Arctic sea ice is reducing by about 10 percent per decade.
- The political stability of the area makes it attractive as a safe shipping route.
- The Arctic Council, a high-level intergovernmental forum for Arctic states and peoples, was set up in 1996.



Mikko Niini, senior management advisor and ex-managing director of Aker Arctic Technology

has been developed and sound experience gained in the ‘easier’ areas,” he says.

As companies become braver in pushing their operations into the frozen ocean, the solutions they find are bound to spread to the wider shipping industry, says Tim Kent, technical director at Lloyd’s Register.

“With any engineering that goes into operations in the Arctic and Antarctic locations, the challenge is multiplied by several factors because an environmental incident in those locations just would not be accepted by society. Being such a different environment, it will drive technology. Solutions once demonstrated as possible here can then be adopted and embraced by the broader industry,” says Kent.

As the Arctic ice melts, more icebreakers will be needed to traverse high Arctic areas. The challenge posed to the machinery on board through the impact of ice on the propeller will drive further innovation.

“There has been a huge amount of innovation in the industry with electric propulsion and azimuthing pods that can push or pull a ship through ice,” says Kent.

You can see this core technology spreading out across the world as these project develop.



But while these units have been successful in Baltic ice and other sub-Arctic conditions, they have not been tested in multi-year ice conditions in the high Arctic yet.

### Unproven concept

Azipod is the ABB Group's registered brand name for their azimuth thruster, a propulsion unit consisting of a fixed pitch propeller mounted on a steerable pod, which also contains the electric motor that drives the propeller.

"These units haven't seen much multi-year ice," says Rob Hindley, Arctic technology lead specialist at Lloyd's Register in Canada. "Now we need to ensure they are strong enough to withstand multi-year ice floes. We are beginning to see a gradual creep towards more harsh operations for Azipods, but I would say the concept still has to be proven in those conditions."

"Probably the harshest conditions to date have been experienced by the Azipod-equipped Norilsk Nickel containerships operating independently year-round between Murmansk and Dudinka along part of the Northern Sea Route."

Developed in Finland, Azipod propulsion was originally installed on Finnish fairway support vessels for maintenance operations in ice. They were later retrofitted to Finnish tankers that have been used in the Arctic since the 1990s and are part of virtually every new icebreaker design.

"Azipod has been a game changer for ice-going ships. ABB have been very successful in that market. They have the technical foundation to support new developments where we push the boundaries further," says Hindley.

He agrees with Ninni that the size of ships operating in the Arctic will have to increase if economies of scale are to work. "The original Finnish ice-breaking cargo ships were about 26,000 metric tons displacement, so we're seeing a big step up to 120,000 metric tons with the 170,000 cubic meter tankers for the Yamal project."

Even bigger vessels will likely mean an increased steel weight, but while scientists are exploring the

## Arctic sea routes

### Northern Sea Route (NSR)

- Runs from the Atlantic to the Pacific Oceans along the Russian Arctic coast.
- Navigable during its entire length in summer and early autumn, depending on ice conditions.
- It is 40 percent shorter than using the Suez Canal.
- The Russian government opened the route to foreign vessels in 1991.
- In 2012, the 288-meter LNG carrier Ob River became the first ship of its kind to transit the NSR.
- Most vessels using the route do not carry cargo but if they do, it is liquid.
- Its potential as a summer season trade lane to and from Asia has been explored in recent years.
- The port of Vardø, important for the future of oil exports, has been in operation for over five years.

### Northwest Passage (NWP)

- Runs from the Atlantic to Pacific Oceans along the coast of North America via the Canadian Arctic Archipelago.
- Until 2009, pack ice prevented regular marine shipping throughout most of the year.
- Reduced pack ice due to climate change has made the waterways more navigable and some seasonal traffic has occurred.
- Hazardous multi-year ice is still found on the NWP.
- Contested sovereignty claims over the waters may complicate future shipping through the region.

### Future Central Arctic Shipping Route

- A route through the central Arctic Ocean will depend on a significant reduction of the ice thickness in that area.
- The multi-year ice cap covering the Central Arctic Ocean has been changing drastically over the last 50 years.
- Scientists predict that vessels with ice-breaking capabilities could navigate the central Arctic waters before 2020.

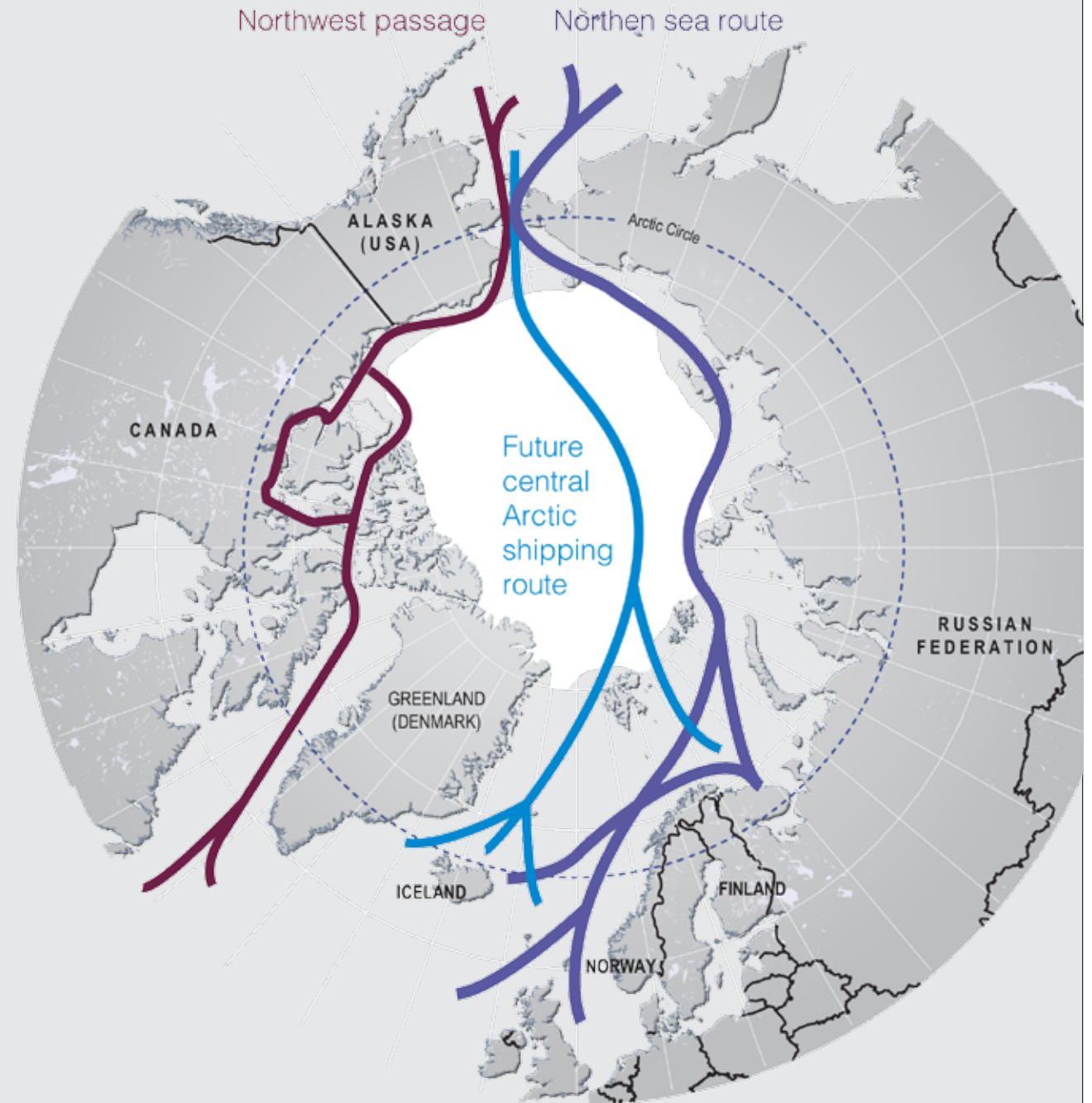





Robust Azipod propulsion units for Arctic applications are designed based on the required ice class.

We've only really started to touch on what can be done.

use of high-strength steels, Hindley cautions that this is again a case of going "step-by-step into the unknown."

#### Finns leads the way

As Hindley says, "We have to be conservative in the structural design process for such large ships because we don't have a firm understanding of the ice loads. We've only really started to touch on what can be done."

"We also need to look at alternative materials for the ice belt structure and close the knowledge gap of the nature of ice loads as the ship size increases. But what we have learnt from before should always guide us in addressing the technical challenges of the future."

Those challenges will necessitate cooperation across countries, as has always been the case with Arctic shipping and operations.

"The Finns are the leaders in Arctic shipping technology because they've done so much of it. ABB

chose to house their Azipod factory in Finland. That's where the knowledge is. You can see this core technology that is based in Finland spreading out across the world as these projects develop," says Hindley.

He cites the recent Polar icebreaker designs between Canada-based STX Marine and Aker Arctic for the Canadian Coast Guard as an example. Asian and Russian icebreakers are also designed in Finland.

The Yamal project is another example of cross-nation Arctic cooperation. Independently-held Novatek, Russia's second biggest gas producer after state-controlled Gazprom, has a 60 percent stake in the project, while the remaining 40 percent is split between French oil and gas giant Total SA and China National Petroleum Corporation. The project is expected to produce 16.5 million metric tons of LNG per year.

The newbuild project for the ice-going LNG carriers was awarded to Daewoo Shipbuilding and Marine Engineering (DSME). The vessels will be able to operate in temperatures as low as minus 50 °C. The ships will use Azipod propulsion to move ahead in open water and in moderate ice conditions, and astern to cut through heavy ice up to 2.1 meters thick. Operations will be mainly without escort or icebreaker support.

"Operating LNG carriers in ice-locked waters year-round requires the highest standards in safety and efficiency," says Veli-Matti Reinikkala, head of ABB's Process Automation division. "ABB is very proud to have its technology selected for such a project."



Rob Hindley, Arctic technology lead specialist at Lloyd's Register, Canada

Text: **Helen Karlsen**

Photos: **Mikko Niini - Aker Arctic, Rob Hindley - Lloyd's Register**

For more technical insight into the use of Azipod propulsion for ice management and operational profitability, see pages 80 and 121



Andreas Sohlen-Pao

## In the zone

From a tower overlooking Singapore's bustling harbor, BW Group's young and dynamic CEO Andreas Sohlen-Pao shares his insights on keeping shipping in the profitability zone.

### **What is the best strategy for maintaining the profitability of the BW Group?**

It's difficult to stay consistently profitable in an industry with so much volatility, especially if you include the volatility of asset prices and mark the assets to market on a prudent basis. The best strategy is to have a strong enough balance sheet to withstand the volatility and the less profitable periods, and to avoid becoming overexposed in any particular segment.

A good example of this is the LPG sector, where we are actually very positive about the outlook but did an IPO and sold down some shares. On the one hand, we have been investing very heavily in anticipation of significant demand changes, but we are also conscious that sharing risks and rewards with other investors is a way to balance our portfolio so that we are not overexposed in a particular segment.

Public market investors and fund managers take exactly the same approach, investing in a number of companies to achieve diversification. If you are a public investor, it is unlikely that you would put your entire fund into one stock.

### **Why did you choose Oslo for the IPO of BW LPG?**

Oslo has a strong historical standing as a maritime capital, with a self-reinforcing cluster of peer

companies attracting other companies. This is visible in the maritime cluster (bringing together ship ownership, finance, Class, insurance, technology, etc.) and also in the stock exchange. The Oslo Børs is a strong exchange for shipping and offshore. It is well regulated and maintains good quality, but is not overly burdensome with the listing process. It shows how, once you have the right grouping of companies, you also get the right investor base and attention from banks and research analysts.

### **How does government regulation and legislation impact profitability in the shipping industry?**

Governments have a critical role to play in establishing the rules of the road and ensuring a level playing field. Regulation is essential as long as it is well considered and gives people reasonable time to adjust. We have seen plenty of good legislation in the industry to improve safety or environmental performance.

A prime example is the Singapore government's approach in creating a stable, long-term fiscal framework where they give visibility on how companies will be treated from a tax perspective. This is very important when we are investing in long-term assets. We have seen in other places that changeability and volatility in tax policies make it very difficult to sustain a business.



Sohmen-Pao at the company headquarters

On the negative side of government involvement, we see more governments starting to intervene and undermine the market by insisting on local content or providing other forms of subsidy or protection. While the intention to support local industry and employment may be understandable, insisting on a high percentage of local content in a short space of time can be damaging for investor confidence and local consumer interests. If international companies cannot find suitable partners or local capabilities (for instance, to build high-value ships or offshore units), then they may simply refrain from investing. If local players are protected from the normal workings of a competitive market place, then consumers will usually suffer from poor value goods and services.

So governments have to walk a fine line – providing the right regulatory framework and incentives to stimulate business development but always ensuring a sufficiently open market place so that capital is allocated efficiently.

#### **Which factors govern the profitability of the BW Group?**

The factors that preoccupy us currently are the market, the impact of supply and demand, capital flows – because that often determines the supply side of the market; costs, particularly of fuel; and talent with its related impact on safety and performance.

#### **The energy market is as volatile as the shipping market these days. How is it affecting you?**

In terms of the market, we are at a juncture where energy flows are changing and the demand side is quite hard to read. Shale gas is a transformative phenomenon, and I am not sure that anyone has a perfect answer to how it is all going to develop and which areas will be the winners and the losers.

Some of the market changes hinge on political decisions, for instance, how much LNG or crude oil will be allowed to be exported from the U.S., where will it flow, how will the geopolitics unfolding in Eastern Europe develop? We work hard to understand the market and flows but we are careful not to think we can see perfectly into the future. What can help is to take a balanced approach either in terms of diversification or in terms of how one structures the balance sheet, so as to be prepared for surprises.

#### **Capital is flowing into shipping again. Is this a positive development?**

We are a very capital-intensive industry, so the availability of capital has a large impact. When capital is insufficient, it can create a lot of stresses in the system. But it is almost more dangerous when capital is over-abundant, because people start ordering too many assets and create over-supply. We are seeing a bit of that now because of all the liquidity in the global system. Some of it is being channeled through banks, some through private equity firms, and some through public markets. But a lot of it is finding its way into shipping. And that creates a high risk of overcapacity.

We are trying to manage this by looking at whether there are ways to collaborate and benefit from these capital flows, but also with an eye to the risks that they create. It is a case of trying to look at it positively, while being aware of the downside. We definitely haven't always gotten it right. We just try to get it right as often as possible and to be disciplined. We should not get too carried away when things look good, and not get too depressed when things look bad.

#### **How do you handle the challenge of spiraling bunker costs?**

We focus on fuel costs, both as a business cost, but also because of the impact we have on the environment. We try to manage fuel consumption on our existing fleet very proactively, while looking to invest selectively in new fuel-efficient modern ships.

Just scrapping older ships has a huge environmental impact too, so it is not a silver bullet solution. We are also investing actively in maritime and environmental technologies, both as a user and also as an investor and incubator of good ideas.

#### **What are the keys to making wise investments in technology?**

We go beyond just being users of new technology to help promising technologies and young companies develop. This involves capital investment to help them grow, as well as providing access to our engineering input, test bedding on our vessels, our industry network, and so on.

In terms of the stage of investment, we look for proven technologies that have ideally achieved some level of

sales. We seldom come in and seed an idea when it is just a concept. In terms of technology type, we do a wide scan to ensure we understand the entire landscape and do extensive research to ensure that we pick the best in class. We have a company called Green Marine Capital fully focused on this. We believe one needs a rigorous, focused approach to pick the best technologies.

We have a dual objective here: firstly, it is good business and we can underwrite our own return on investment; secondly, it has a very positive social impact. Talk is cheap – it is easy to talk about how the industry should do more, and we are all on a collision course with the environment. We are trying to do something about it and put some energy and capital behind it.

Text: **Kevin Reeder**  
Photos: **BW Group**





“More than 20 of our projects have been done entirely within this yard,” says ABB’s project manager at Jurong Shipyard Hallvard Aamlid.

**G**enerations catches up with Aamlid at the end of a busy day before he heads off to something he enjoys regularly in Singapore: a concert by a world-class performer. This time his wife joins him from Norway, on one of her many visits during the 11 years he has been stationed in Singapore.

---

It’s not so much about reducing the documentation as making the use of it more interactive.

It is not unusual for suppliers to have a site office in a yard during the commissioning of a project. But what has kept a full ABB project team working inside this yard for 11 years? Including seven drill ships built in Brazil and other projects to which this office contributed, the total number of its projects is about 30. Up to 10 semi-submersible rig projects in various stages were active at one time.

“We still have the rigidity and structure of documentation and databases and still transmit formal letters, but instead of preparing piles of paper and sending them, we deliver them upstairs,” says Hallvard Aamlid. “If there is an issue, the document controller comes down and talks to us. It’s not so much about reducing the amount of documentation as making the use of it more interactive.”

#### Face to face

“Face-to-face project meetings happen several times a week,” according to Aamlid. “We have managed to tune into what they need,” he says, “and you have a much better relationship with people when you talk face to face.” His experience is that communicating via email often creates conflicts since you cannot respond to an immediate reaction. Face to face you can quickly adjust your communication and deal with issues before they escalate to a time consuming discussion that involves several parties. Instead of trying to nail each other down to the details in the documentation, the yard and the supplier teams work together to find the shortest route to the desired result.

---

### Face-to-face project meetings happen several times a week

Charges for work outside the agreed scope of a project are a common source of conflict in projects won on price. Unforeseen problems, as well as delays, can cause overruns that damage both profitability and relationships.

“We hardly ever have discussions about our hours with the yard,” says Aamlid. He attributes this to the fact that the ABB team has worked closely with the yard to plan and re-plan commissioning to make optimal use of resources. This improves the predictability of scheduling.

Being on site and following a project closely has enabled the team to bring in specialists for short assignments when needed. This is better than training several crews on a rotation schedule.

The yard needs to maintain its neutrality on behalf of customers when it comes to the selection of equipment packages. So the model where a supplier holds a permanent project office inside the yard requires that the end customers find ABB’s solutions attractive and competitive.

“We could not have used this model project by project,” Aamlid says. When ABB got its first contract with the yard in 2005 the plan included two rigs. How many people would be needed permanently was not easy to define, then a third and fourth project came up. “We took an opportunity and adapted to the situation,” says Hallvard Aamlid, who has worked on an unbroken chain of projects with Jurong Shipyard ever since.

# Back to the future

“It’s time to bring automation back into vogue in our company.” With these words, the senior management at APM Terminals conceived the first automated container terminal in Latin America – and decided to face the future head on.



By the second quarter of 2015, phase one of the APM Terminals’ Lázaro Cárdenas Terminal 2 (TEC 2), located at the port of Lázaro Cárdenas on the Mexican Pacific coast, is set to begin operations. The facility is being developed in three phases, the first with an annual throughput capacity of 1.3 million TEU.

“With Lázaro Cárdenas we had the opportunity to say ‘Why don’t we automate?’ and ‘Why don’t we try to automate more?’” says Tiemen Meester, Vice President for Business Implementation at APM Terminals, headquartered in The Hague.

The foundation for the first phase of TEC 2 was officially laid at the end of 2012. This stage involves constructing a 750-meter quay, installing state-of-the-art cargo handling equipment, creating an intermodal rail facility and developing an automated 45-hectare container yard and gate facility.

### Automation underestimated

“The driver behind our decision to automate was simple,” explains Meester. “If you look at our large portfolio of terminals, you could say the automated terminals are underestimated. But we considered the fact that while they don’t move at the highest speed,

## Lázaro Cárdenas Container Terminal

Lázaro Cárdenas Container Terminal (LCT) is a transshipment hub at Lázaro Cárdenas, Mexico’s second busiest port in the state of Michoacán. The first phase of the new terminal will give LCT a land area of 63 hectares, three berths and a total quay length of 930 meters. Phase 2 will be built on 85 hectares of land adjacent to the new terminal.

The TEC 2 project will improve efficiency for shipping lines as well as exporters and importers, alleviating bottlenecks and improving cost efficiencies in the transportation of containers through Lázaro Cárdenas.

they are highly predictable. So we said it’s time to bring back automation in our company – because of the stability it brings.”

Meester says the management created several business cases for TEC2, “basically deploying more capital expenditure (capex) on equipment. But we were surprised at how much more efficiently and how many more containers we could put through the same footprint. So the higher equipment capex was off set by lower construction cost, meaning for the same money we could automate the yard.”

TEC 2 represents an investment of almost \$900 million. The International Finance Corporation and partner banks provided a \$300 million loan for its phase 1 construction. With so much money at stake, it’s not surprising that Meester counts the commercial gamble as the biggest risk his company takes when building a new terminal.

“It’s an enormous undertaking. You put hundreds of millions of dollars into your civil works, buying cranes, equipment and technology.

### Opex a major factor

“This is shareholder money and we need to provide a return. How much money you need to mobilize up front to buy what is a very important consideration. If you can build a terminal for \$500 million or \$450, we all want the \$450. But making sure we get the most efficient terminal built for the lowest cost is in our interest.”

Meester says the operating expenditure (opex) number is also a major factor behind how APM Terminals designs and makes business cases. “It’s sometimes complicated to put a terminal together, but, at the end of the day, we’re in a simple business. We lift boxes out of a ship, onto the quay, then out of the yard – and vice versa. It’s about what’s the least costly and most efficient way to lift those boxes.”

“It’s not just that automation costs more. I think that’s misunderstood sometimes. The business case was pretty straightforward at Lázaro Cárdenas: We could get a more efficient and stable operation for the same money that we would have spent on a non-automated terminal.

## APM Terminals

APM Terminals is one of the world’s leading port operators with a global terminal network of more than 70 facilities in 68 countries and on five continents.

[www.apmterminals.com](http://www.apmterminals.com)



Tiemen Meester

As he explains, “The trend towards electrification is undeniable. More and more new terminals will be electrified and thus pretty quiet. As for the dark place, that’s down to automation, which is here to stay. It’s going to be more important as we move forward. I’m not saying everything is going to be 100 percent automated. There will be modules. In some places the gates will go quicker. Yard automation is already here, with crane automation and automated stack profiling – it’s all being integrated over time.

“The fact that there are no longer people walking between the machines is a fantastic safety feature. People are operating the machinery from other places. Hence I make the joke that the lights can go out.”

At APM Terminals it seems the lights are on full beam and directed firmly at the automated future.

While the decision to opt for automation at Lázaro Cárdenas was seen by some in the industry as last-minute, Meester says it was really the result of having time to optimize the design after winning the tender. “If you want a perfect business case, you can work for a year. But usually there is a deadline imposed, especially with tenders. I’ve seen situations where we’ve had to respond in six weeks. Then you aren’t going to get a fantastic product. At other times, we’ve been able to work on a tender for four or five months. “When there’s more time, that’s when creativity really comes into play. I think Lázaro Cárdenas is a good example of that. We had more time so we made some changes to improve the facility.”

Most of the play was around the layout of the footprint. When fully completed, TEC 2 will provide shipping companies with 1,485 meters of berth, 16 ship-to-shore cranes, and an annual throughput capacity of 4.1 million TEU.

But APM Terminals’ latest decision to automate is not just the result of a passing trend. Of that Meester is convinced. He bears this out in his answer to what the terminal of the future will look like: “A quiet dark place.”

Text: **Helen Karlsen**  
Photos: **APM Terminals**

For more technical insight into automation at container terminals, see page 130

# Complexity behind the success

“We expected to start Phase 2 in 2016, but the market demanded we start in 2012 – after just two years of operation.”

**T**his rapid growth in a new venture might sound like luck to some, but it is the result of four years of planning, study, negotiations and world travel.

Victor Muñoz, project director at TC Buen in Colombia, knows all about that. He came onto Phase 1 of the project for a new container terminal at the port of Buenaventura in 2010. That was three years after the idea was first conceived and a year before it started operations. Now he is overseeing Phase 2.

“When we started, there was nothing here. It was a green field. Buenaventura was moving around 600,000 TEUs per year. Now we are moving 1 million TEUs,” he says.

“It’s a very complicated project. At each phase you need civil works, equipment and dredging. You need to deal with the Colombian authorities and your providers.”

But the complexity starts way before phase implementation. Obtaining finance, studying the Colombian and the region’s economy, considering the competition and visiting other ports are just some of the aspects Muñoz has been involved with.

The concept of a new terminal at Buenaventura was first mooted in 2007, when Colombian developers



Victor Muñoz

GEPSA had a meeting with TC Buen’s parent company, Barcelona-based GRUP TCB. The developers were looking for a global player to help them realize their ambition of a new terminal on Colombia’s Pacific coast.

“Usually you compete for a project like this. But the developers contacted us, so we came here to talk to them. Together we approached the local government and have been working closely with them ever since.” Civil work started in August 2009 and was completed 18 months later. Operations started in Jan 2011. For the first three months, TC Buen worked together with the existing port, Sociedad Portuaria de Buenaventura.



“At the same time, the construction company was working with the civil works, so we split the terminal into two: one part for operations and other for civil works.”

Sociedad Portuaria de Buenaventura is still TC Buen’s main competitor, yet “we share customers because we each don’t have enough capacity on our own,” explains Muñoz.

“But a third competitor would be too much,” he adds. “There isn’t room for three. The quicker we develop our project, the better. Once we finish the third phase, I don’t think it will be easy for a third player because we will have the customers. But we build phase by phase to prevent overcapacity.”

### Gateway to the Far East

In preparation for Phase 2, Muñoz and his colleagues undertook a number of studies. “We created simulations, models, scenarios, looked at the economy, trade, the container industry. We realized this port had interesting development potential.

“Colombia is the gateway to the Far East because most vessels need to pass through the Panama Canal, so the natural way for cargo is from the Far East to Buenaventura.”

At the end of 2012, the priority was financing and engineering. Financing agreements with local and government agencies, as well as a pool of mainly American and German banks were completed the following year. Equipment suppliers in China, the USA and Finland were also contracted.

Dredging, due to start this year, will be done in two phases. Negotiations with Colombian authorities will be complete at the end of September to enlarge the turning basin and the width of the canal.

TC Buen decided to implement OCR to Phase 1 to reduce the risk of smuggling, piracy and narcotics trafficking, as well as to improve performance. “We started operations without OCR but after using it for 10 months, we could already see an improvement in performance,” says Muñoz.

While considering OCR, he visited terminals all over the world and says, “It wasn’t easy to find a terminal

with OCR integrated into an existing terminal operating system (TOS) as we have it.”

TC Buen has its own in-house TOS that has been developed between all the GRUP TCB terminals. “At the time we asked ourselves whether we should develop our own OCR, or look for an existing OCR system that could integrate well with our core system.

“When I was investigating this in 2009–2010, there were three main suppliers of this new technology, all very similar in terms of price and quality. We went with APS mainly because it had the most integrated solution. We could automate at the shore, in the yard, at the gate, all with GPS.”

APS Technology Group, a member of the ABB group, provided optical character recognition (OCR) and related automation solutions. The company has installed, and will maintain over five years, the following:

- Automated gate systems
- Ship-to-Shore (STS) crane OCR
- Tractor identification for STS and rubber tyre gantry (RTG) cranes
- Software to enable real-time notification of system exceptions via local and remote clerks
- Container inventory and position determination system (PDS)

“If we have a problem with the OCR server, we call on San Diego, but if there’s a problem in our core system, we talk to Barcelona,” says Muñoz. He adds that the ideal situation would be for all GRUP TCB terminals with OCR to be managed by one provider.

### Different from other countries

Automation is being implemented in stages at TC Buen and Muñoz says the aim is to have a fully automated terminal in five years. The next step is GPS for all the equipment. At present, this is only used on the RTG cranes.

Muñoz believes automation is not just for “megaports” but that small terminals in developing countries are good candidates for this technology. “We may be a small port, but we have important technology. We are a reference for Colombia and South America,” he says.

Two factors made automation an easy choice at TC Buen: the fact that it was started from scratch and weak union interference in Colombia.

“A container terminal operator always wants automation because you decrease your costs and increase your margins. But you still need to operate. If you change to automated systems, you need to have the same, or higher, level of productivity. I saw that I had the opportunity to start with new technology here that would achieve just that.”

“Also, in Colombia, we don’t have the same problems that the United States or Spain have with the unions. Here, the dockworkers are employed by our company. Of course, they can have some kind of union, but it’s not the same as in other countries.

“This sort of thing is decreasing in Europe, but still in Spain if we say we want to start with automated stacking cranes, we hear that we will have a problem with the union.”

Besides the unions, there are other factors to consider for implementing new world technologies in developing countries. He points to the lack of a stable electricity supply in Colombia as a case in point.

While GRUP TCB is a small operator, when seen in the global context, Muñoz says it has a lot of potential. “We have a department dedicated to looking for new opportunities and places to build new ports. The latest one we’re working on is on the Pacific coast of Guatemala.”

What about the future of TC Buen and its subsequent phases? Muñoz says, “We have a 30-year concession up to 2037. Initially, we thought the fourth phase would be complete by 2021.” Clearly, this will happen a lot sooner than planned.

Text: **Helen Karlsen**

For more technical insight into automation at container terminals, see page 130



## Terminal de Contenedores De Buenaventura (TC Buen)

- Owned by Spain-based GRUP TCB
- Situated at Colombia biggest port on the Pacific Ocean
- Started operations in 2011 with Phase 1
- Three more phases planned
- Phase 2 started in 2012 and due to open this year
- Specializes wholly in the handling of containers
- Mostly import/export traffic
- Separate coffee, sugar, loose cargo, import and export warehouses
- Security system with 235 cameras
- Closest port to Colombia’s industrial belt
- 137 km from the Panama Canal and midway between North and South America

## GRUP Marítim TCB (GRUP TCB)

- Headquarters in Barcelona
- Established 1972
- Designs, owns, operates and manages container terminals
- Thirteen terminals in Europe, Americas and Asia Pacific regions
- Also operates rail terminal facilities for intermodal traffic
- Over 3.3 million TEU throughput per year

# Entrepreneur with a vision

Having a vision that fires you with enthusiasm, and for which you are prepared to work day and night, is often the start of entrepreneurial success. Leon Adegeest, managing director of ABB subsidiary Amarcon, based in the Netherlands, knows the feeling.

“I used to work alone in my garage until 3 a.m., then wake up at 7 a.m. to continue. I don't think it was healthy but that's what I did. I believed in what I was doing and I had to do it properly,” says this Dutchman with a doctorate in hydrodynamics, who developed the world's first onboard ship motion forecasting system.

In 2003, he stood at the quayside watching the *Sealand New York* leave the port of Hamburg. As the Costamare-owned containership set sail, he still remembers thinking “Wow! That's the first vessel with OCTOPUS-Onboard.”

Today, the name OCTOPUS denotes a suite of hardware and software products that improve the safety and efficiency of ships at sea. Besides forecasting and measuring motions, the range includes speed advice, fuel consumption monitoring and DP (dynamic position) capability advice. The “arms” of OCTOPUS gather input from sources such as the weather forecast, ballast computer and motion sensor, which it then interprets to support the shipmaster in making decisions.

OCTOPUS products are now used on all types of ships around the globe. Around 80 percent of

semi-submersible heavy lift vessels use OCTOPUS-Onboard, as do more than 70 vessels belong to French container operator CMA-CGM. Some of the biggest, most impressive offshore vessels have also been equipped with OCTOPUS-Onboard. For instance, Subsea7's *Seven Borealis*, as well as the *Stanislav Yudin* and *Oleg Strashnov* from Seaway Heavy Lifting and the *Pacific Osprey* and *Pacific Orca* from Swire Blue Ocean. Maritime universities all over the world train future maritime engineers with OCTOPUS-Office.

“In the beginning, it was difficult – you had to beg a company to export their data to OCTOPUS. These days it's a bit easier because the client says, ‘We want to have OCTOPUS, you have to make sure that you export to OCTOPUS,’ so this has become a nice advantage over the years,” says Adegeest.

## Working relentlessly

This success is something he could only have dreamt of as he worked relentlessly in his garage. His vision was to create an application that could be used in ship operations, to the same technological standard as that used for building a ship. At the time, while a vessel was designed and manufactured at the highest technical level, once it started operating, the



## Amarcon

Amarcon, a fully owned subsidiary of ABB, provides monitoring and forecasting software solutions for performance and availability optimization of sea-going vessels, and is the leader in vessel motion prediction solutions. ABB acquired Amarcon in August 2012 in order to strengthen its long-term growth strategy in vessel information and control systems. Amarcon and ABB offer the widest portfolio of marine advisory and optimization systems to the maritime market.

Amarcon Colleagues (from left) marketing and sales coordinator Tim Ellis, manager installation and support Martin Eilander, software engineer Jan Kedde and managing director Leon Adegeest at their new office in Dalfsen

captain merely received a weather forecast by fax. He then interpreted this as best he could based on his experience.

Adegeest developed the OCTOPUS range from the Seaway seakeeping software designed by Johan Journeé, associate professor in ship and offshore hydromechanics at Adegeest's alma mater, Delft University of Technology.

---

In the beginning, it was difficult – you had to beg a company to export their data to OCTOPUS.

Adegeest visited a host of maritime companies to gain an understanding of their needs regarding seakeeping and monitoring of fleet performance. His vision was to create a program that delivered practical information for decisions at sea during ship operations.

But things didn't always go smoothly. Adegeest, who had previously worked at the Maritime Research Institute in the Netherlands and Det Norske Veritas (DNV) in Norway, started Amarcon, an independent consultancy company in hydrodynamics, with two colleagues in Norway in 2001. He began work on the motion forecasting software, but the company flopped due to a lack of projects.

Adegeest then found himself back in the Netherlands working for Imtech Marine & Offshore in 2002. As luck would have it, the contacts he made there landed him a project for Germanischer Lloyd that was exactly in line with his vision about navigation and decision support at sea.

He was not the only one thinking this way. At the time, many other companies were working in the same area. The competition was fierce to be first with a working system. Adegeest rose to the challenge.

"I don't like to deliver something that doesn't work, and if it's technically possible, then it's just a matter

of doing it," he says. "A lot of people say to me they'd like to start their own company and I tell them to just do it. Either you do it or you don't, but you can't do it half-heartedly."

Do it he did. After receiving the OCTOPUS-Onboard order for Sealand New York, Adegeest started Dalfsen-based Amarcon B.V., which ABB acquired in 2012.

#### Going for another first

Besides watching the first OCTOPUS-Onboard ship sail away in Hamburg, another highlight he remembers is a meeting in Marseilles with the newbuild director of CMA-CGM.

As Adegeest tells it: "He told me he was happy with the first installation of OCTOPUS-Onboard, then he said, 'Hey, Leon, could you make us an offer for the other vessels?' I said, 'Sure. Which ones?' When he answered 'All of them,' meaning 35 vessels, I was just blown away."

These days Adegeest is planning to move Amarcon to new offices close by in Dalfsen towards the end of the year. Once again, he is going for a first.

"ABB Benelux wants to make these offices a showcase for a new way of working. We had some workshops with HR experts on how to combine private and working life and place-and-time-independent working.

"They thought the new Amarcon offices could be a pilot for a new way of working. We'll have some offices, some cubicles where people can sit and do quiet work, sofa corners for informal meetings. It's going to be a more playful environment than what we have now, more creative looking. We want it to reflect our innovative nature."

With Adegeest at the helm, that innovative quality is sure to be reflected.

Text: **Helen Karlsen**  
Photo: **Amarcon**

---

For more technical insight into OCTOPUS-Onboard, see page 67

# Sloshing worries many



Sloshing in LNG tankers is a major concern of the LNG industry. With the demand for these vessels growing, the problem is becoming more pressing.

Indeed, the Netherlands-based Maritime Research Institute describes sloshing, on its website, as "the most emerging technical issue and concern of the LNG industry associated with the application of membrane technology."

Sloshing happens when a ship carrying liquid cargo moves in waves. The ship motions excite sloshing, which in turn further affects the vessel's motions and vice versa.

Leon Adegeest, managing director of Amarcon and developer of OCTOPUS-Onboard, which includes sloshing warning and avoidance features, has spoken to a number of captains to try to understand the sloshing phenomenon.

"Think of walking with a bowl of soup and how difficult it is to stop the liquid moving. Captains have told me you can't miss a sloshing event on board a vessel. When it starts to roll, it's like a gun firing beside your ear, they say," he explains.

#### Move in dangerous ways

"The impact of the liquid gas hitting the sides of the tank is very violent. It can really damage the inside – maybe not the first time but definitely after several times. Gas and cracks in tanks is not a nice combination," says Adegeest.

Besides damaging the tank, sloshing can make a vessel move in dangerous ways. As Adegeest says, "The big vessels have 40x46 meter-wide tanks without a bulkhead in the middle, so when there is sloshing, the vessels starts to 'dance'. I've seen videos at an oil company showing a tanker moving violently beside the terminal."

Assessing the strength of containment systems during sloshing is a complex process still the subject of extensive international research. Two modern trends that contribute to sloshing are:

- Most tank vessels carrying LNG nowadays generally do so with larger tanks than in the past.
- The production of LNG is moving towards offshore regions, where so-called floating LNGs (FLNGs) operate. Shell's Prelude is an example of such a mega-production facility. These FLNG's are unloaded by transferring the LNG to tankers coming alongside. These tankers are exposed to wave and swell conditions and will always have phases during the loading operation when the tanks are not full.

---

Text: **Helen Karlsen**

For more technical insight into LNG carriers, see page 150



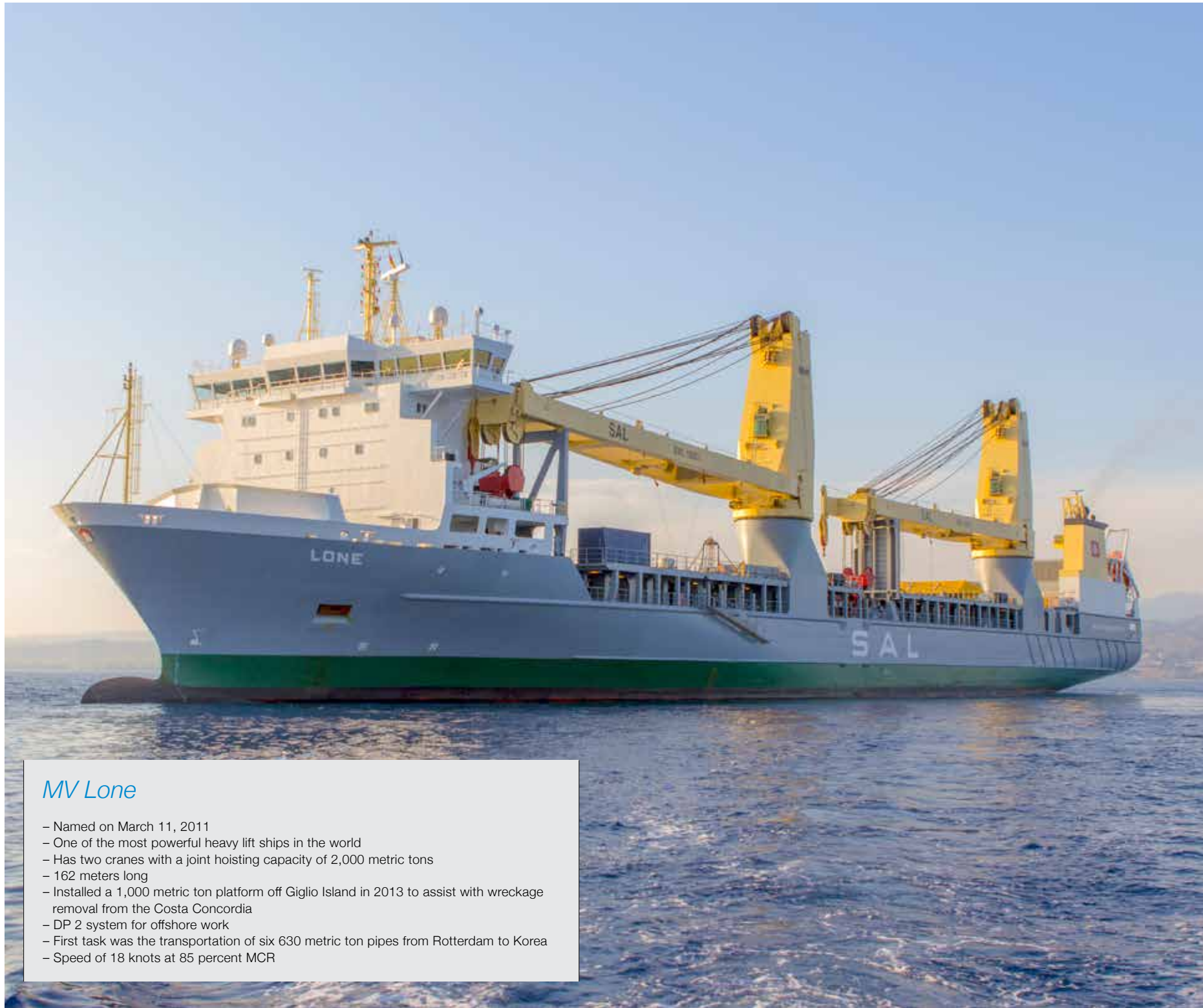

### *MV Lone*

- Named on March 11, 2011
- One of the most powerful heavy lift ships in the world
- Has two cranes with a joint hoisting capacity of 2,000 metric tons
- 162 meters long
- Installed a 1,000 metric ton platform off Giglio Island in 2013 to assist with wreckage removal from the Costa Concordia
- DP 2 system for offshore work
- First task was the transportation of six 630 metric ton pipes from Rotterdam to Korea
- Speed of 18 knots at 85 percent MCR

# Heavy lift getting heavier

The heavy lift market is seeing a clear tendency towards heavier and larger cargo that often cannot be treated routinely, says Capt. Rüdiger Bauer, corporate director of engineering and ship management at SAL Heavy Lift GmbH in Hamburg.

**F**or this reason, ship motion and RPM monitoring software will be more widely used in this sector.

“Often, wave height restricted designs are the only solution to transport such cargo, and with the aid of products such as Amarcon’s OCTOPUS-Onboard, more weight and size critical sea transports become feasible. They offer control measures to facilitate such wave restricted sea transports that could not be conducted in unrestricted environmental conditions,” says Bauer.

Three years ago, SAL Heavy Lift stepped into the offshore market with the acquisition of *MV Lone*, which it then fitted with OCTOPUS-Onboard. The vessel is equipped with a modern dynamic positioning system dedicated for offshore installation projects.



## SAL Heavy Lift GmbH

- Established in 1865
- Headquarters in Hamburg, Germany
- Member of the “K” Line group
- Specializes in sea transport of heavy lift and project cargo
- Fleet of 16 heavy lift vessels
- Network of offices around the world

SAL transports the following types of cargo:

- Oil and gas equipment
- Modules and preassembled units such as living quarters
- Port handling equipment, such as cranes and shiploaders
- Port construction structures
- Floating cargo such as yachts and pontoons
- Heavy machinery such as mining equipment, printing presses and locomotives
- Power plant equipment

A clear picture of the ship’s seakeeping behavior is even more critical for successful offshore installations, where sea and wind conditions need to be much milder than for standard sea transportations.

“With a growing offshore market, other ships in our fleet are likely to be equipped with OCTOPUS-Onboard,” says Bauer. He adds that the company appreciates the “holistic approach of using OCTOPUS-Office in combination with OCTOPUS-Onboard, which is deemed a rational strategy for the heavy lift sector.”

### Plans to train entire fleet

In brief, SAL Heavy Lift use OCTOPUS-Office for the onshore planning and design of *MV Lone*’s heavy cargo transport and OCTOPUS-Onboard to assist the shipmaster to safely transport cargo by monitoring the ship’s responses and RPM.

“So far, we have trained the shipmasters on *MV Lone* to use OCTOPUS-Onboard. Our hydrodynamic experts in the engineering department design and plan weather restricted sea transports with OCTOPUS-Office.”

With more weather restricted sea transports in the pipeline for the company, there are plans to train the shipmasters of SAL Heavy Lift’s entire fleet to use OCTOPUS-Onboard.

“We bought the system to help our shipmasters trace optimum routes on the basis of monitored seaway-induced accelerations and ship motions in adverse seas. We need accurate information about this dynamic ship behavior to secure large-sized and heavy cargo safely on all ocean routes during all seasons,” says Bauer.

He adds that the company also appreciates the system’s fuel-saving functionality in the far more often encountered milder seaways. The system is also used to perform route planning by accounting for forecasted seaway conditions provided by MeteoGroup’s shipboard weather forecast system SPOS.

“There are very few, if any, systems on the market that offer the variety of functionalities that OCTOPUS-Office and OCTOPUS-Onboard do. Because OCTOPUS-Onboard was one of the first shipboard



*MV Lone* Installing an underwater turbine, the world’s heaviest cargo

decision-making support systems, its long experience was a strong argument for choosing it.

We wanted a system that matched our requirements. Robustness is also important to avoid costly downtime of the system. When this does happen, we need

prompt high quality support at short notice, as well as smooth maintenance and regular upgrades,” concludes Bauer.

Text: **Helen Karlsen**  
Photos: **SAL Heavy Lift**





Finn Bjørnstad with Singaporean associate Lesley Tan

# Sign on the dotted line

Leading international maritime lawyer Finn Bjørnstad paves the way for huge deals that make a difference to a company's profit line. He tells *Generations* about his work.

**What are some of the projects you work with?**

I typically work with oil and gas investment projects, where I act as a service provider for a company going into an offshore project, such as the development of an oil field somewhere in the world – typically in Mexico, Indonesia or Brazil. I typically act related to a construction contract and a contract for an oil company to lease this unit for a certain time. Then I do all the legal aspects of that project together with my team.

**What are the obstacles to getting contracts signed?**

It depends on the project but very often it's timing – to be able to deliver a certain asset at a certain place and time and at a certain cost. So, it's timing and cost. Those can be the two most serious obstacles.

**How do you mitigate legal, technological and other risks in contracts?**

I could write a book about that. What we do is make a risk matrix for projects, which will be different from country to country and project to project. We have to be very focused on the major risks. But it's not my job to tell clients not to take risks, only to help assess risk and to price it correctly.

**What do you think is crucial to decision-makers when you make deals with them?**

It's important to understand and respect how they,

and everyone involved in the negotiation, think. They have their own agendas and considerations and you need to understand and respect these to build up the right negotiation atmosphere.

**What are typical deal-breakers?**

Big surprises that happen late in the process. Very often this is to do with financing, that you're not able to finance the terms you have negotiated and the project proves not to be bankable in the end.

A lot of money may be at stake when you are preparing documents that will formalize huge commitments.

## Wikborg Rein & Co

- Established in 1923 in Norway
- About 250 lawyers in Oslo, Bergen, London, Singapore, Kobe and Shanghai
- Specializes in shipping, offshore, energy and natural resources
- Finances corporate and cross-border transactions
- Handles all aspects of dispute resolution and maritime emergencies
- Lawyers qualified in English, Chinese, Singaporean, Brazilian and Norwegian law
- Asian Maritime Law Firm of the Year, Lloyd's List 2012 and nominated as Global Maritime Law Firm of the Year, Lloyd's List 2013



## Finn Bjørnstad

Managing partner of Wikborg Rein, London  
– head of Offshore Team

Bjørnstad (55) has spent his whole working life at Wikborg Rein and has led the offshore team for the last ten years. Currently based in London, Bjørnstad has also worked in Singapore and Japan. He has been acknowledged by Chamber & Partners in the “Leaders in their Field” category for Energy: Oil & Gas, Shipping Finance.

Most of his clients are banks and shipping or offshore companies. He and his team assist them with:

- Newbuilding or vessel conversion projects, in particular related to offshore projects with tender work, joint venture agreements, risk assessment, financing and operational matters
- The financing, purchase, sale and charter of ships and offshore vessels, and M&A transactions related to shipping and offshore companies
- Financing of various shipping or offshore activities around the world in the private capital market, both for investors and brokers

### How does that feel?

Sometimes it feels like a big responsibility but it also feels like my clients put a lot of trust in me. I think my job is to ensure that I remember all the bits and pieces when the client is just focusing on closing the deal. Sometimes I feel that I’m creating more problems than I’m solving but that’s part of my job. Balancing these things is an art.

### What do you like most about your job?

I’m very inspired by the young people I work with, particularly when I see them coming into my team and proving themselves; in that the client responds positively to what they do. Having the client take us into the early stages of a project is also rewarding. Then we feel we are in a partnership and not just an external advisor.

### How willing are banks to finance offshore and shipping projects today? And what other sources of financing do you see becoming available to rig and ship owners?

Traditional banks are still active in this market but I think they scrutinize projects more than they used to and they don’t have the appetite to finance speculative projects without good cash flow. Chinese banks and lease companies are becoming very active but, primarily for projects with a Chinese content. The bond market has been very active over the last few years both for both project financing and unsecured corporate debt. I think the trend is that banks and bonds are working more together in a capital structure, and that banks welcome the bonds to offload the risk taken by banks. In short, capital is definitely available for good offshore projects.

### What is the impact of your work on the profitability of the industries or companies you work with?

I think our understanding of the business is important and adding value for our clients, particularly related to risk assessment and pricing of services. We bring to the table experience from previous projects, so we know what to do and what to look for.

Text: **Helen Karlsen**  
Photo: **Wikborg Rein**

Capital is definitely available for good offshore projects.

# Investors want proof of new technology

It’s always a risk participating in a project with new technology. Someone needs to take that risk first – and it’s not easy to find the right investors to do that. So says international maritime lawyer, Finn Bjørnstad

For this reason, innovators need to work hard to prove their technology before they can attract finance for it, he says. “It’s about showing that it works and that your product provides better productivity than whatever else is out there. You see this a lot in the North Sea, where new technology is being developed almost daily.”

To get onto the radar of decision makers, technology has to be proven to save them money, be safer and good for the environment. “I think the green technology that has been developed over the last ten years is a very good example of that,” says Bjørnstad.

“But it’s very difficult to attract capital for development of new technology, both from banks and equity, without having an underlying contract in place to secure income, where the risk for the new technology to work is assumed by the client. So strict speculative investments that depend on new technology are much more difficult in today’s market.”

### Difficult to make a case

New technology also has to prove itself more quickly in new projects “because you are competing with existing technology. If you are going to substitute

existing technology with new, you need to be able to substantiate that from day one. That’s been my experience.”

When new technology promises improved operational efficiency but represents a higher cost up front, it can be difficult to make a case for that technology, says Bjørnstad.

“Of course, decision makers need to calculate their return on a long-term basis but maybe the problem is that many investors have a short-term view. They are not willing or able to appreciate the cost saving in the new technology.”

This is especially true for long-term projects, says Bjørnstad. “For shorter contracts with oil companies – say over 15 years – it’s much easier to substantiate the value of cost-saving measures.”

Text: **Helen Karlsen**

# Shipping moving at its own pace

As the biggest supplier of ship management services in the world, V.Group knows a thing or two about staying profitable. The group's Chief Technology Officer Andrea Zito spoke to Generations about present and future prospects for the shipping industry.

## How do you explain the success of V.Group?

Our success is, very simply, based on the quality of the service we render. We are uncompromising on safety and quality, and this has been widely recognized by the industry. The choice we took years ago to be independent has paid off. We are one of the few independent service providers, so we don't have any vested interest in the vessels or their assets. The market recognizes this as an advantage.

Another success factor is our worldwide footprint. With offices around the world, we have always been flexible and close to our client. Our biggest asset is the competence of our people. We have the largest global network of recruiting agents, moving about 30,000 seafarers all over the world. Almost 95 percent of them come through our own recruiting offices.

Finally, we are one of the few companies that cover the entire spectrum of the shipping industry – not just cargo, but also passenger vessels. We are the largest independent passenger vessel manager with about 50 vessels under management. A few years ago we

successfully entered the offshore market, where we manage about 20 large offshore units. So we are expanding into that market as well.

## Turning to profitability and decision-making: Why is capital expenditure still the main consideration, rather than operational efficiency, when it comes to ordering newbuilds?

That's largely true, but, lately, I think we're seeing a big change. But it's a slow change because shipping is a traditional industry. However, we do see the focus shifting towards operational efficiency among some of the leading operators. I think this will accelerate in coming years. There's a lot more awareness of operational efficiency, and this has gained pace over the last five to ten years. We also see more awareness of the reliability of vessels. You can't have the luxury of not being compliant anymore.

## Capital is invested for return on a given time horizon, and efficiency gains only make sense for the long perspective – what is the typical time horizon of a shipowner?

That's difficult to answer because we've just come out of a lot of turmoil in the shipping industry. The dust hasn't settled well enough yet to give us a clear scenario on time horizons. The market is still dominated by private investors. Private groups can move much more quickly than larger organizations with slower decision making and heavier governance. If you are a publicly listed company, you can't sell your business and buy another according to gut feel or a quick swing of the market. So, the traditional ship owners are still very successful, namely the Greeks, the Japanese, the Norwegians. They move quickly from one type of vessel to another.

There are areas, like the cruise business or offshore, where you have mainly long perspective investments – because it's a steadily growing market with some strong fundamentals. But for other sectors, like oil tankers or bulkers, the roller coaster of the last few years is far too recent for long perspectives.

## What is the future outlook for shipping?

We may have steadier freights in the future so that investors can make more long-term plans. I think we will see trends for consolidation. We'll see traders or mining companies entering the market and being involved more heavily with ownership of assets – for example, the large VLOC market – to secure their long-term routes. We have seen a lot of activity from financial investors planning their investment for medium- to long-term returns. So, the industry will evolve slowly towards consolidation and a more settled pattern of long-term investment. We are moving out from the turmoil but not yet.

## How should equipment manufacturers and providers of new technology stay profitable in the current climate? Should they take bigger risks? For example, look at performance-based compensation?

We have several projects going with some manufacturers where we see the focus staying on operating costs but a longer-term strategy coming back in. I'm talking about ships on long-term charters managed by top-class operators more interested in the long-term financial return. There you may have space for performance-based compensation based on key performance indicators (KPIs) or other forms of turnkey management, where the technical operational



Andrea Zito

The dust hasn't settled well enough yet to give us a clear scenario on time horizons.

expenditure is wrapped and guaranteed. We already have agreements based on KPIs, as well as lump sum crew costs. We are now considering some scenarios where the technical running costs are also in a form of a lump sum. Obviously, we are thinking of turnkey management together with some selected manufacturers. And I think that this could be an interesting development for ship management in cases where there is a strong partnership between the manager and owners/operators.



V.Ships is a division of V.Group

The industry isn't mature yet, but it will get there because nobody wants to take risks on operational costs any more. Compromising on reliability, safety and environmental considerations isn't an option any more. I think there will be a clearer and more transparent commitment between charterers and owners – so that owners who are investors will have certainty about long-term returns. The panorama may change but I don't know how quickly.

#### Will this affect key performance indicators (KPIs)?

Yes, definitely. We have been working through InterManager (see ...) on a big project to look at the sharing and setting of KPIs for various ship types. A better understanding of KPIs will lead to more transparency and better recognition and reward for quality and performance.

### V.Group

- Leading ship management services provider
- Established in 1984
- Headquartered in London, Glasgow and Monaco
- Provides marine and offshore maritime personnel
- Offers technical, engineering, consulting, inspection, testing, repair and maintenance support services
- Provides a range of commercial services, such as procurement and contracting
- Operates in the commercial shipping, cruise, energy and defense sectors
- 80 offices around the world

### InterManager

InterManager is the international trade association of the ship management industry. Members are in-house or third-party ship managers, crew managers or related organizations and businesses from throughout the shipping industry.

Collectively, InterManager members are involved in the management of almost 5,000 ships and responsible for some 250,000 seafarers.

The association represents its members at international level and is committed to improving transparency and governance in the shipping world and ensuring high standards are maintained throughout the ship management sector.

Text: **Helen Karlsen**  
Photo: **V. Ships**

# Remote monitoring link to fuel efficiency

Anticipating the maintenance of equipment on board ships in order to increase fuel efficiency could be a “real game changer in the future,” says Andreas Zito, chief technical officer of the V.Ships group of companies.

Condition-based maintenance, through remote monitoring, is usually considered a way to prolong intervals between maintenance. Now engineers are discovering a correlation between maintenance and fuel efficiency. The idea is to anticipate maintenance in a way that will increase fuel efficiency.

“It's a pretty novel concept,” says Zito, whose company is working with universities and manufacturers in this area. “We are doing some trials and testing, developing some systems. It's all still at the research and development stage because it's quite a novelty. But in the future, we may be able to offer something to others.”

The research involves using data to develop “self-learning tools” that can adapt to and indicate trends for maintenance and fuel efficiency. Zito stresses that, since his company is a service provider, “we don't directly control the asset. So we can't dictate what systems are installed on a vessel.

#### Next big step

“We're not a manufacturer, so we need to team up with manufacturers. But what we can bring to the table is a lot of know-how about operations. And that's quite a good mix because our knowledge of what is important and how to link it to various information is vast.”

Zito believes the future of ship management is more integrated decision-making support, both on board and ashore, through remote monitoring. Data analysis and data filtering is the way forward, he adds. “It's my firm belief that to manage ships effectively, there will be a lot of support from remote monitoring, remote diagnostics and condition-based maintenance.”

Decision-making support in the form of programs for captains and officers in emergency situations, such as the evacuation of passenger vessels or progressive flooding, already exist. But, according to Zito, more integrated decision-making support for the management of vessels is the “next big step.”

“Ships are no longer insulated from the world, so you can efficiently collect data onboard and transmit it ashore. However, what is missing – and what I think the industry will develop – is expert systems able to filter the data and indicate trends. All the data is useless if we can't interpret and filter it,” concludes Zito.

Text: **Helen Karlsen**

For more technical insight into ABB's remote monitoring and diagnostics, see page 129



# Uncovering value

“I wouldn’t use the term ‘creating value’,” says Allen Thomas, describing his work with the customers of APS Technology Group. He prefers to talk about “uncovering the value that’s captive within their operation.”

“From a marine terminal perspective, it’s all about the efficiency of that operation,” he says, “finding out what the capabilities are, identifying the potential that’s there.” APS offers automation solutions to improve the productivity of both marine container terminal and intermodal and railroad operations.

## Working with change agents

“We start with the concept of the why, not the what,” he says. “We’re not selling a widget, in a lot of cases, we’re selling a new way of looking at a problem they’ve had for a long time. In every organization you have progressive individuals who want to initiate change. They have done some research on their own and we help uncover the value that’s there.”

“We start from simply asking questions about the operation that we’ve seen. In certain cases they’ve contacted us, and they have a vision. In other cases, they look for a better understanding of what’s possible.”

“They’re usually quite passionate about their operation. We know the market and terminal operations – that establishes a bond and some credibility,” says Thomas. “Then we begin fact finding to figure out what and how important their problems are and assign a value to each of those problems.”

## An iterative process

“It’s a slow, iterative process. Basically, we like to identify KPIs (key performance indicators),” says Thomas, “We look at how they make money, and at different scenarios on productivity gains or cost reductions, reallocation of labor, extended hours, whether they’re paid per lift or transaction. We put all that into the business case and it’s a simple cost-benefit or a return on investment (ROI) calculation”.

“Based on the data given by the customer, we present what we believe are the benefits from the solution we could provide, with an estimated payback period. We like to interview our customers and then report back on the status to make sure we have a

shared understanding of both the challenges and the process of how to get to a solution.”

“It’s a consultative process, because they may not be ready to proceed. The value may not be there, and we want to know as soon as possible, because if there’s no value in it, it’s best for us to focus on other opportunities.

## A team decision

“If you’re buying multimillion dollar systems, there’s a decision making team, and we like to understand the responsibilities and concerns of each, because the CFO has different boxes to check than the operational head. There’s a technical aspect, there’s an engineering aspect and then there may be a corporate or a board level involvement, as well. We like to see that there is agreement on the value that should be realized.”

“After a few sessions of analysis, we have a brainstorming session and report that back in a pre-proposal with ideas to improve on the issues. If we don’t get any confirmation from that point, we don’t proceed. If we do, we start building the business case on the underlying metrics. We show what the customer is missing by operating ‘as is’ versus the cost of implementing the solution – what the ROI would be.”

## Value proposition first

“The sale comes after that value proposition has been put to bed,” Allen Thomas says, not denying that there is a sales aspect, but emphasizing that in more evolved markets the clients are technically savvy, they have very savvy procurement departments, who cannot be approached from the perspective of just trying to make a sale. “That’s distrustful”, he says. “It’s not just a search for revenue. We were forced to change our approach many, many years ago because some of our customers are large, multinational industrial entities, and for us to survive, we had to really understand that we only prosper when our customers prosper.”



Allen Thomas, Vice President of Operations at APS Technology Group

If you’re buying multi-million dollar systems, there is a decision making team, and we like to understand understand their individual responsibilities and concerns.

Text: **Johns Ensbj**

# Real-time is too late

To further optimize the handling of shipping containers, information should be made available to the entire logistics chain as soon as it is created, a team of container terminal automation specialists agreed.

**G**enerations arranged a “brain trust” session with these specialists to envision solutions to this challenge. The group met in San Diego and comprised vice president of operations at APS Technology Group (member of the ABB Group) Allen Thomas, Clara Holmgren, product manager at ABB Crane Systems and Patrick Vloemans, global business development manager for ABB Port Solutions. Their mission was to come up with thought-provoking ideas that could bring the container industry to its next level of efficiency. That is not a modest ambition since the industry already is a low cost and highly efficient part of the container supply chain.

## A standard with deep impact

The session began with a discussion about what the worldwide establishment of containerization has meant for cargo flow; i.e. allowing producers, buyers and retailers to adopt just-in-time principles and reduce warehousing and overproduction on a global

scale. The revolution started with transport, but rolled on to change supply chains and enabled factories to reach a new level of efficiency, one that is dynamically changing as lower cost, higher quality sources become available. “But what if this revolution is just halfway into its potential?” the group asked.

## Inaccurate and missing information

As they elaborated, the physical standardization of cargo flow was never followed up by a similar standardization of information flow. This poor state of affairs in information handling is illustrated by the fact that the misdeclaration of container weights has been an ongoing problem in the shipping industry. Following the accident involving structural failure of the container ship MSC Napoli in January 2007, the containers that were removed from the vessel were weighed. Of the containers that remained dry, 20 percent had a weight difference of more than three tons when compared with the shipper’s declaration. The largest difference for a single container was 20 tons.



Each container should have an information object “in the cloud” from the moment a shipper places his order. Weight, cargo category, priority, destination as well as updated event data should be accessible. Traceability, predictability and pre-processing could optimize every part of the logistics chain.

## Regulation kicks in

In May 2014 the Maritime Safety Committee of the International Maritime Organization (IMO) decided on, and approved for adoption in November, draft amendments to chapter VI of the international Safety of Life at Sea (SOLAS) treaty to require mandatory verification of the gross mass of containers. These requirements will come into force before May 2016 and will require a new type of information flow in the container industry.

## No lack of technology

The weight of a container can be controlled every time a crane touches it, the team agrees. That crane can

pair the weight data with the identity of the container by OCR (optical character recognition). The data can then be fed into the terminal operating system and forwarded to a stowage validation system to form an accurate loading plan that leverages the full capacity of each ship. In this way, a safety margin used to compensate for inaccurate weight data is eliminated and ballast water is no longer used to fill the gap between reality and declared weight. Our “brain trust” team sees this as the spark that could ignite a whole new concept around container information handling.

The regulatory requirement to share one piece of information could pave the way for a cloud-based,



Patrick Vloemans, Allen Thomas and Clara Holmgren

unified handling of information objects reflecting not only the weight, current and previous location and other events for tracing, cargo category, destination and priority. In addition to the benefit it could have within container terminals around the world, the data could be shared in as much detail as the business interest of the stakeholders allow.

#### A common interface

Our ABB brain trust sees no problem in delivering the crane automation system that updates the container information object, wherever it is, with accurate data on mass according to the upcoming IMO regulations. Terminal operating systems could share event data, and shippers, fleet managers, insurers, cargo owners and analysts would make use of that data as required. All the industry needs is to agree on an interface. What web developers call a REST-based API (application programming interface) is the common solution that allows any system to talk to any other system in our time and age. One such approach to standardization of interfaces that may hold promise has been drafted and is being evaluated by the leading container port industry organization, PEMA, the Ports Equipment Manufacturing Association.

#### What the data can do

Why should each container have an information object “in the cloud” from the moment a shipper places his order and the supplier attaches a number of SKUs (stock keeping units) to this reservation? According to our team, the point is not the availability of real-time data itself. It is what you can do with the data in terms of pre-planning and pre-processing:

- The logistics company will be able to organize its cargo flow earlier.
- Accurate information ahead of time would drive automation and result in cost reductions as well as higher precision and predictability at terminals.
- Once event data is added, each link in the transport chain will enjoy a new level of predictability, further reducing storage and warehousing, from shipment of materials to the factory to the arrival of finished goods on store shelves.
- Customs can pre-process shipments and no longer delay the cargo flow.
- Checking the weight at every handling point and additional data from e.g. x-ray systems could reveal tampering and possibly customs fraud.
- Bottlenecks can be eliminated through simulation

and modeling of workload, days and weeks ahead of time, allowing for better resource allocation and use of electricity required to complete the day’s container movements.

- A vast number of agents and intermediate players, who are necessary due to the lack of information transparency, would no longer be needed in the transport chain.
- Shipping lines can copy the practice of the express package industry to create new products for priority freight that escape fierce price competition and focus on customer value.

#### A coordinated approach needed

One shipping line or one terminal operator alone cannot establish a new standard for information sharing in the container industry. Our team concluded that a complete cargo information loop would have to be created. The new solution would not be a new network. The ships and the operators are already there. Rather than a new technology or system, the quest is for an improved working method.

The big hubs are already highly automated gateways and the potential is in better connecting smaller terminals – “spokes” – to the highly optimized intercontinental cargo flows. This could allow shipping lines to create new products to reach the market and then trickle down to the multimodal handling, maybe even to automated warehousing connected to the ports.

Eventually, the return on investments in information systems and terminal automation needs to come from the freight customer, while satisfying every player along the chain with a better margin than before. A coordinated approach would be needed between partners, which could demonstrate a new level of performance to the industry at large.

#### The group of world shakers

Our team’s beachhead project would involve partners who could work together to establish at least two new marine or hinterland terminals linked to an existing major gateway. The partners and their roles would be:

- A shipping line with ambitions to create a new, faster freight product with higher predictability and value – a product that would be differentiated from the low-priority cargo.

## APS Technology Group (APS)

APS Technology Group (APS), a member of the ABB Group, is a leading provider of optical character recognition (OCR) and process automation solutions for marine and intermodal container terminals. ABB acquired APS in February 2013 in order to strengthen its long-term growth strategy in container handling and terminal automation markets.

- Terminal systems providers that can facilitate control and automation that better secures high-priority cargo a fast track through the system.
- A software vendor with a leading market position that would provide an interface between a new and the conventional working method.
- Government partners with a growth agenda and ambitions to pre-process customs in an all-electronic information flow.
- A port operator that sees the project as the start of a new network of smaller terminals.
- A financier with a vision of pushing for new technologies that improve efficiency and sustainability

At the outset of the workshop, the team set 2020 as a relevant time horizon for implementing a new information flow. “A bold, but not unrealistic vision,” they concluded.

Text: **Johns Ensby**



# Price is not everything

Maritime technology providers should become better at getting their customers to look at the lifecycle costs of their products, not just the initial purchase price, says Topi Vesteri, executive vice president of Finnvera.



With a 11 billion Euro exposure in Finnish exports, the export credit agency is able to gauge the success factors for a wide range of exports, especially in the country's vital maritime industry. In Vesteri's opinion, this industry has been more challenging due to overcapacity and the very global nature of its business. In addition, many banks are reducing their exposure in this sector. Export credit agencies (ECA) have been forced to fill the gap. His own ECA now offers financing in addition to guarantees.

Vesteri believes that while innovation is what makes a company competitive, sourcing and a diversified

partner and customer base are equally important, as is investment in research and development.

"Competition is tough and buyers focus too much on price. They are looking for a quick return on their investment, but value for shareholders should also be important."

#### Best overall package wins

"From a financier's point of view, every party plays its own important role. The yard and the investor/operator put the whole package together. Smooth cooperation between all parties is important and best overall package wins," he says.

Looking at this from the Finnish and Nordic angle, Vesteri says knowledge of Arctic maritime solutions and high-value niche products such as Azipods, icebreakers, cruise ships, LNG technology and ship automation provide great opportunities for maritime companies over the next decade.

These are examples of innovative technical solutions that have found their way onto the market as a result of close collaboration between customers, designer equipment manufacturers and the yards. The shift of focus from price-based to lifecycle cost decisions is already starting to happen among "reputable players."

"They are focusing more on social and environmental issues and an important part of this is cost efficiency during the lifetime of the investment."

So while technology providers may have a challenge in communicating lifecycle benefits, ultimately it is up to their customers' technical and top management to find the best solution for their company, says Vesteri.

Text: **Helen Karlsen**  
Photo: **Finnvera**

# Technical insight

---

78 Solutions that benefit vessels throughout their lifetime

[Enhancing the availability and efficiency of operations](#)

---

80 Azipod® C gearless propulsor improves operational profitability

[Long-time market leaders in the most demanding applications](#)

---

87 Azipod® propulsion ideal for ice management

[Flexibility in different ice management situations](#)

---

93 Onboard DC Grid – one year in operation

[Real-life operations confirm theoretical fuel-efficiency and other gains](#)

---

99 Optimizing the design and power management strategy of tugs with Onboard DC Grid

[A joint study between Singapore's Nanyang Technological University and ABB Singapore](#)

---

110 Total integration reduces installation and commissioning costs

[Complex engineering and class rules no longer hinder total integration](#)

---

---

121 Vertical integration offers a total propulsion solution

[The more the system knows, the more it is able to give efficient advice](#)

---

130 Automated container terminals are taking off

[More terminals are turning to automation to meet several challenges](#)

---

135 Motion analyses offer superb support on board

[Heavy transport operations benefit at both preparation and transport phase](#)

---

146 Design point can hinder propulsion potential

[Flexible shipbuilding may be a better way to go](#)

---

150 Technology that makes “floating gas pipelines” so reliable

[Advanced engineering enables LNG carriers to keep the world economy turning](#)

---

156 Quality upgrade can meet stricter closed bus rules

[Upgrades for drillships and semi-submersibles are as safe and reliable as newbuilds](#)

---

160 Cross reference

[Pointers to articles by key words](#)

---

# Solutions that benefit vessels throughout their lifetime

**ALF KÅRE ÅDNANES – To some, “profitability” may imply one party taking advantage of another for short-term benefit. However, in developing successful businesses, it is possible, and necessary, to find solutions and relations that benefit all parties; for example, by optimizing performance, reducing fuel consumption or mitigating risks to avoid costly breakdown or off-hire. The Technical Insight section of this issue of Generations focuses on solutions and technologies that enhance the availability and efficiency of operations either being by design or performance – throughout the lifetime of the vessel.**

The two articles on Azipod® technologies (pages 80 to 92) and the articles on Onboard DC Grid (pages 93 to 109) illustrate how design secures availability of ship systems, which is key in securing the revenue stream of the vessel.

Kokkila et al (page 80) show how ABB has brought the Azipod technologies to the next level of performance and reliability during recent years through using real-life operational experience to continually improve the design. Shipping and offshore activities are increasing in Arctic areas, where the environment is harsh and availability for assistance is limited. Arctic operations require vessels that can provide for highly reliable operations, being designed for the purpose and expected environmental conditions. Varis et al explain on page 87 how the Azipod can be designed to withstand even the most stringent class and operational requirements in various Arctic environments in order to secure the performance of operations,

proving the efficiency of designs based on data from real operations.

The Onboard DC Grid was launched by ABB in 2011 as a new design concept for electric propulsion. The drivers for the development were better use of space and fuel efficiency. Now, real life measurements are showing that the fuel savings are as expected from the design analysis. Fazlagic, Hansen and myself present the basic concept for Onboard DC grid as well as results from a recent measurement program on the first vessel in operation with this technology (page 93). As part of a collaboration program with Nanyang Technological University of Singapore, ABB advises students about research on methodologies for optimizing the design and control strategies for a compound power plant with Onboard DC Grid. The objective is to stimulate academic research and attract young talent to explore features of this new concept. Professor Dhupia and his team present parts of a study in this connection on page 99.

## IT's integration into marine

During the last decade, information technology and communication networks have been used in the protection, monitoring and control of electric distribution systems. Recently, these technologies have been adopted in marine systems as well. Among their advantages are seamless integration horizontally and vertically into the system and less interfacing and cabling for installation. Pensar explains the characteristics and benefits in his article on page 110. Matilainen et al elaborate on the vertical information flow from the propulsion system through the automation and advisory systems (page 121).

IT, control, and power systems to those that have been integrated into marine systems have been applied at container ports for some years. Henriksson describes in his article on page 130 how a fully integrated system helps to optimize the operation and flow of container processing at a modern container port.

In the recent years, we have seen software-based advisory programs being used to improve the performance of operations and the planning of voyages and complex operations. These advisory systems are being developed further to be integrated into the information system of a totally integrated package, allowing access to more information and operational data, for more precise analysis and forecasting. On page 135 Adegeest presents methodologies for analyzing and forecasting ship motion, that are implemented in the Amarcon products from ABB.

## Efficient operations are the way to profitability

Ships are designed and built to serve through a lifetime of at least twenty years. Even though building costs are significant, the real means to affect profitability through the vessel's lifetime is the way the vessel is operated; in terms of efficiency, safety and securing the revenue stream.

Over the years, the costs of fueling the fleet has made up an increasingly larger portion of the total lifecycle cost of vessels. As the freight and time charter market is fluctuating, shipowners and charterers have to secure profitability under widely varying conditions. The traditional way of using one design point for which the vessel is optimized is being challenged by the desire for flexibility of operation. Pestana (page

146) discusses the importance of optimizing the design based on the fact that the vessel will have to operate economically over a range of conditions.

Hansen, Nowak and Pestana discuss on page 150 how new technologies have been applied in securing high availability of the “floating pipeline” of LNG carriers that whole nations depend on to provide energy for their societies.

Technology and solutions develop for better and more reliable operations during the lifetime of ships. The modernization and lifetime extension of onboard systems are important aspects of maintaining profitability over the life cycle. Hæhre's article on page 156 presents some of the upgrade solutions that are being offered to the sailing fleet to bring their onboard systems in line with today's technology levels.

To secure profitability from design to life end of a vessel is a complex task. The products, technologies and services that we at ABB provide have a direct impact on the daily profitability of the vessels on which such systems are installed. In this issue of *Generations*, we have selected some of those areas where technology is changing and new solutions are or will be available for newbuilds as well as for the sailing fleet.

## Alf Kåre Ådnanes

Vice president, local business unit manager, Marine & Cranes, Singapore.  
alfkare.adnanes@sg.abb.com



# Azipod® C gearless propulsor improves operational profitability

**KIMMO KOKKILA – ABB’s gearless Azipod propulsors are the world’s best-selling podded propulsors. Azipod X and Azipod VI products are long-time market leaders in the most demanding applications: high-powered cruise ships with up to 20.5 MW power per propulsor and high ice-class vessels operating independently in remote Arctic areas. The “little sister” in the Azipod propulsor family is the Azipod C gearless propulsor series, which is gaining its foothold in the azimuthing propulsor market between 1 MW and 5 MW power – a market that has been dominated by geared mechanical propulsors.**

The Azipod C gearless propulsor was first introduced to the market in the year 2000. It is available both as an open propeller version, Azipod CO, for typical ship applications and as a nozzled version, Azipod CZ (see Figure 1), mainly for dynamic positioning (DP) vessels. The power range of the Azipod C series varies from 1.0 to 4.7 MW. As of today, Azipod C propulsors have gained over two million cumulative operational hours. Deliveries include references from all major vessel segments: drilling, offshore supply, offshore construction, accommodation, heavy-lift, wind turbine installation, research, tanker, ferry and yacht segments.

The Azipod C gearless propulsor is a high-end product that improves three major aspects of operational profitability throughout the vessel’s lifetime: efficiency, reliability and cargo capacity. This article discusses how these aspects are improved as well as provides insight into excellent long-term operational experience.

1 Cross section of Azipod CZ gearless propulsor showing the electric motor location on the propeller shaft.

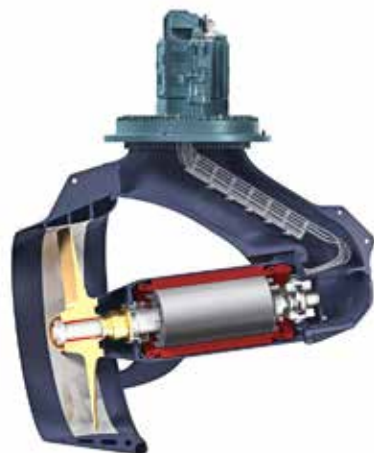

## Efficiency

The most basic factor in the operational profitability of a thruster is the total efficiency of the propulsor affecting the vessel’s fuel consumption. Total efficiency can be divided into four subcategories:

- Hydrodynamic efficiency
- Mechanical efficiency
- Electrical efficiency
- Required auxiliary consumers

## Hydrodynamic efficiency of the Azipod CO

The open propeller version, Azipod CO, is a pulling propulsor. The advantage of a pulling design becomes apparent with higher ship speeds – roughly from 10 knots onwards. In a pulling unit the water inflow to the propeller is more uniform (see Figure 2). There are no low-speed inflow areas in the propeller wakefield as there are in pushing units, where the propeller works closely behind a propulsor strut, as shown in Figure 3, or in an ordinary shaftline propeller that works behind the shaftline support structures.

In addition, the Azipod CO motor module tube behind the propeller works as a “costa bulb” streamlining the propeller slipstream onto the motor module. This avoids flow separation immediately after the propeller hub, which creates additional drag in ordinary pushing propellers and further improves the efficiency and thrust of the Azipod CO propeller.

The more uniform wakefield enables optimization of the propeller blade design, offering higher efficiency and a higher margin against undesired cavitation. In addition, the costa bulb effect of the motor module further increases propeller efficiency. Thanks to a pulling design, the efficiency improvement in transit speeds can even be as much as 10 percent, compared with a pushing propulsor or shaftline.

## Hydrodynamic efficiency of the Azipod CZ

Propulsors equipped with a nozzle, also known as a duct, are normally installed on vessels where DP operation is a major part of the operational profile. The effective thrust per power, i.e. newtons per kilowatt, at zero ship speed or close to zero ship speed, is essential for the hydrodynamic design of a nozzle propulsor such as the Azipod CZ.

2 Pulling Azipod CO propulsors receive undisturbed water inflow, which increases propeller efficiency.



3. The Inflow to the pulling propeller is more uniform, compared with a propeller working behind a propulsor structure.

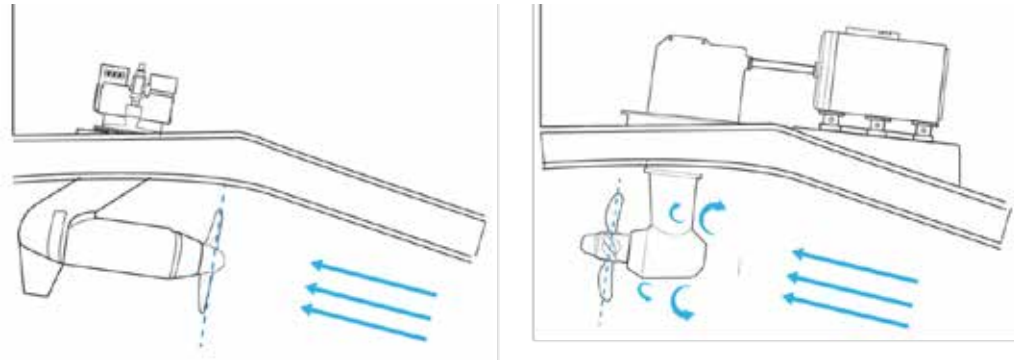

4. The tilted shaftline and nozzle reduces thrust interaction with the hull and nearby propulsors, increasing the effective thrust of the vessel.

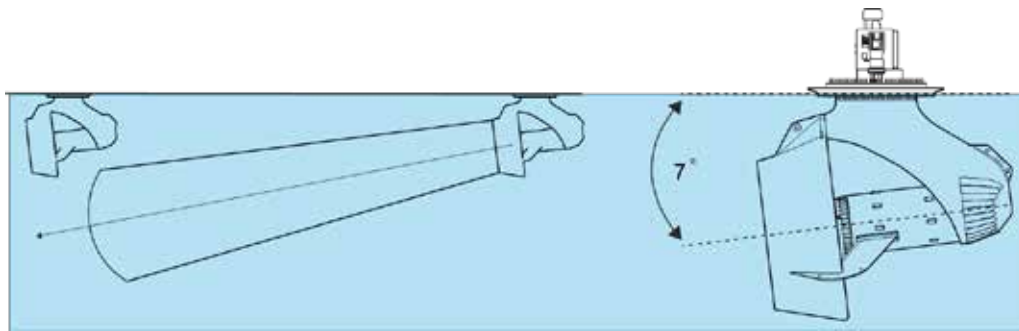

In contrast to transit speeds optimized propulsors, a pushing propulsor is able to reach high thrust efficiency at low ship speeds. As the inflow speed is very low due to low vessel speed, it is more beneficial to keep propulsor structures away from the propeller-induced slipstream.

The Azipod CZ is a pushing unit with a nozzle profile tailored and optimized specifically for the Azipod CZ structure. The strut is located further from the propeller, compared with a conventional nozzle propulsor, providing better inflow and a more uniform wakefield for the propeller also in the bollard condition.

The Azipod CZ was the first nozzle propulsor on the market that featured the significantly tilted (7°) shaftline and nozzle arrangement. The tilted shaftline improves effective thrust significantly as interaction

with the ship's hull or other thrusters can be avoided, especially during DP operation. In addition, the effective thrust of forward thrusters during the transit operation is improved; for example, in the case of drillships.

The effective thrust improvement from a tilted shaftline and nozzle is 10 to 30 percent during DP operation, compared with a non-tilted design.

#### Mechanical efficiency

The mechanical efficiency of the Azipod C propulsion drivetrain is the best in its class. The robust gearless design has only two bearings on the drivetrain providing close to 100 percent mechanical efficiency. The gearless design of the Azipod C propulsor improves mechanical efficiency by about five percent, compared with a conventional geared mechanical propulsor.

5. Typical auxiliary systems needed for the Azipod C propulsor (left) and conventional geared propulsor.

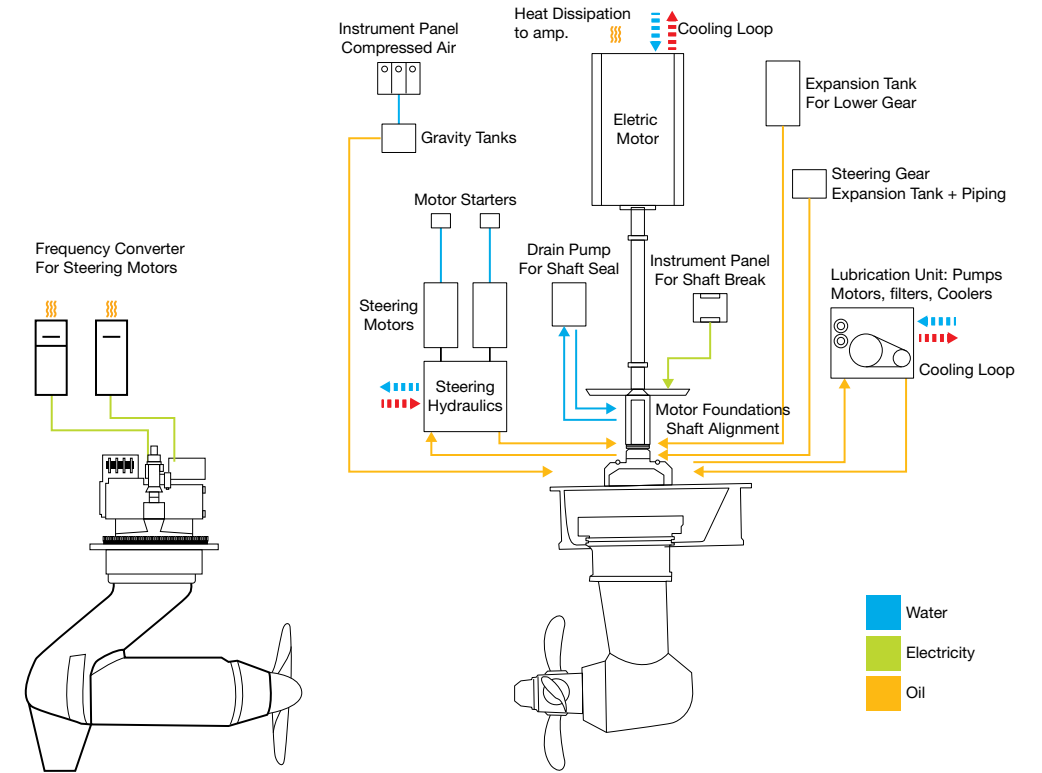

#### Electrical efficiency

As conventional geared propulsors are powered with an inboard induction motor, one unique and advanced feature of the Azipod C gearless propulsor is the permanent magnet propulsion motor. Unlike normal electric motor types, the rotor of a permanent magnet motor is naturally magnetized. Thus, the additional power consumption for magnetizing the rotor is saved.

The electrical efficiency of the Azipod C permanent magnet motor is about 98 percent, while typical induction motors have about 96 percent efficiency at a rated point. The efficiency difference increases further with partial loading. In typical DP loading – for example, at 10 percent of rated motor power – the efficiency difference can be 5 percent between induction and permanent magnet motors.

Compared with a typical induction motor, an Azipod C permanent magnet motor improves electrical efficiency from 2 to 5 percent, depending on the vessel's operational profile.

#### Auxiliary consumers

No comparison of total efficiency can be made without taking into account the auxiliary consumers of the propulsor. Auxiliary consumers that are needed in conventional geared propulsors include, for example, the lubrication system for bevel gear(s) and cooling system for the inboard propulsion motor. These systems require power for lubrication and cooling water pumps, and cooling fans.

In an Azipod C propulsor, the minimum electrical losses of submerged permanent magnet motor are cooled directly to the surrounding seawater passively

6 Azipod C thrust bearing condition after close to nine years of DP operation. The original grinding texture (right) could still be seen on the raceway.



through the motor's casing. Thus, a cooling water pump and cooling air fans are not needed in the Azipod C system. In addition, savings are gained due to the absence of other auxiliary systems that are present in a conventional propulsor, including a bevel gear lubrication system and possible steering hydraulics. See Figure 3 for a comparison of auxiliary systems.

The absence of both gear lubrication and propulsion motor cooling systems improves the propulsor's total efficiency, typically by 1 to 2 percent, depending on the loading profile.

### Reliability and maintenance

Reliability of the propulsor is vital for shipowners. Failure in propulsion may decrease the safety of the operation, especially in rough seas. It may also lead to discontinuation of the vessel operation and significant reduction of the income provided by the vessel.

Normally, propulsors on ships are maintained during dry-docking of the vessel every five years. However, there is some push from owners and operators to increase dry-docking periods from five to seven years or even more.

In the offshore business, semi-submersible drilling rigs, for example, are not dry-docked at all and their many propulsors, usually eight per rig, are overhauled by demounting a few propulsors at a time. The change-out of propulsor is carried out underwater with the help of divers. The extra replacement unit is changed-in and the demounted propulsor is overhauled (critical components inspected) and put in service rotation.

7 A seminar at the ABB Houston Ship Channel workshop included presentations and a hands-on session to examine the condition of used Azipod C components.



The Azipod C design has some major advantages to ensure safe and reliable operation over the overhaul period:

- The gearless and simple drivetrain has a minimum of mechanical parts that wear, making overall reliability superior.
- The multistage shaft seal has a primary seal and two backup seals. The leakage from the primary seal can be monitored, giving sufficient planning and preparation time for maintenance in the case of a damaged primary seal.
- The Azipod C motor module is pressurised to avoid any water ingress into the propulsor.

Long-term experience with the Azipod C propulsor is well documented. So far, the longest continuously serving propulsors have been in operation for close to nine years in a rig before an overhaul. Several guests at an offshore oil and gas industry seminar, held in February 2014 at ABB's Houston Ship Channel workshop facility, were able to see the condition of the critical parts taken

out from one of the long-serving Azipod C propulsors. The Azipod CZ propulsor was disassembled one week before the seminar and it came fresh out of operation after a swap-out at the end of 2013. The components showed hardly any wear and tear and most of them could be reused after a thorough inspection and partial reconditioning. See Figure 6 for an example of the critical component condition.

The seminar included a hands-on session where the audience could touch and inspect components such as the thrust, slewing and propeller-end bearing,

shaft and slewing seals and the service brake. The strut of the unit and the stator and rotor of the propulsion motor were exhibited for inspection as well. The event was very well received by guests from the oil and gas and offshore industry, including visitors from drilling companies, shipyards, operators, classification societies and designers (see Figure 7).

Excellent long-term operational experience with Azipod C propulsion gives ABB the confidence to conclude that a 10-year overhaul interval during DP operation is achievable with Azipod C propulsors.

8 The number of critical components on the Azipod C drivetrain, such as bearings (upper) and gear wheels (lower schematics), is significantly lower, compared with a typical Z-drive type geared propulsor.

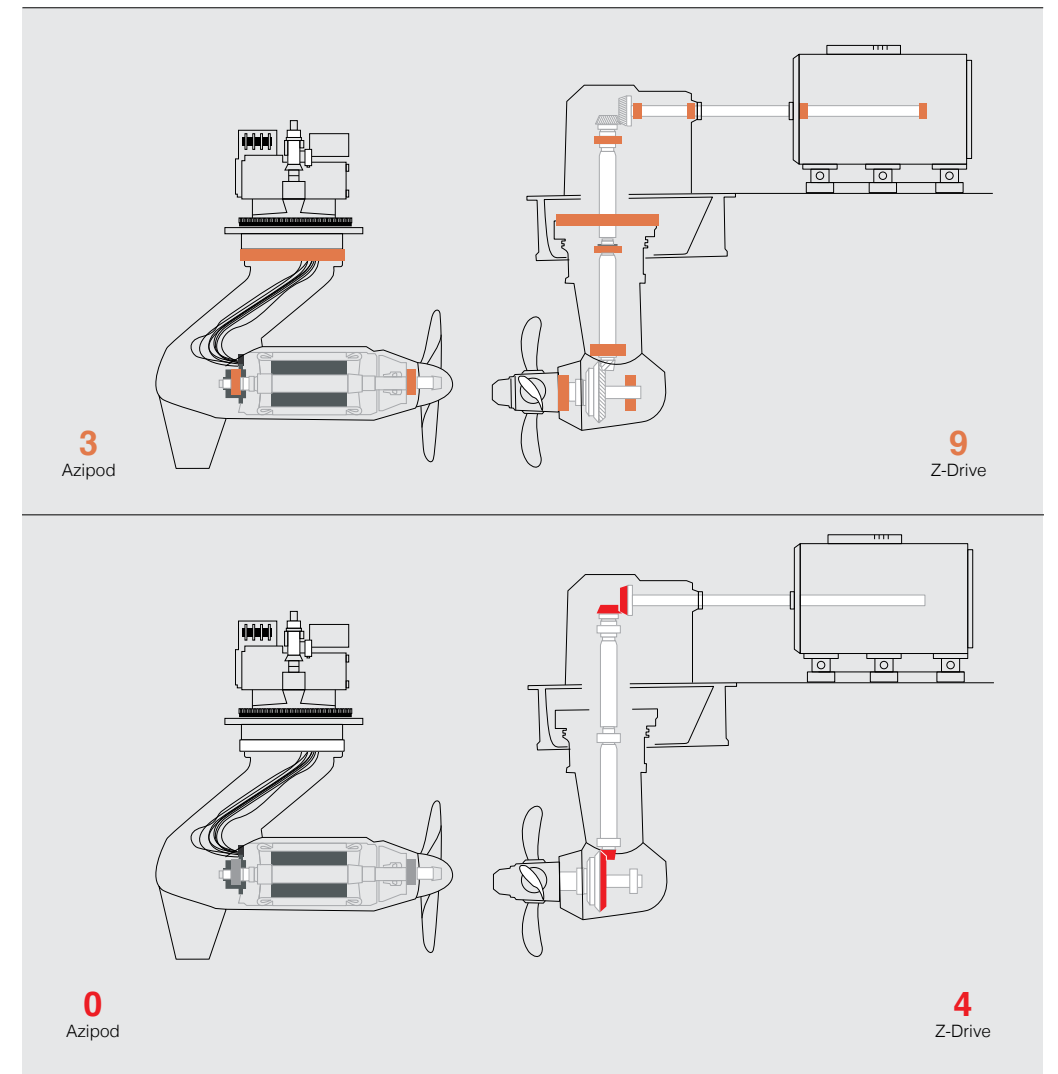



9 The Azipod propulsor saves the footprint and space as the conventional onboard propulsion motor (marked with red arrow) is not needed.

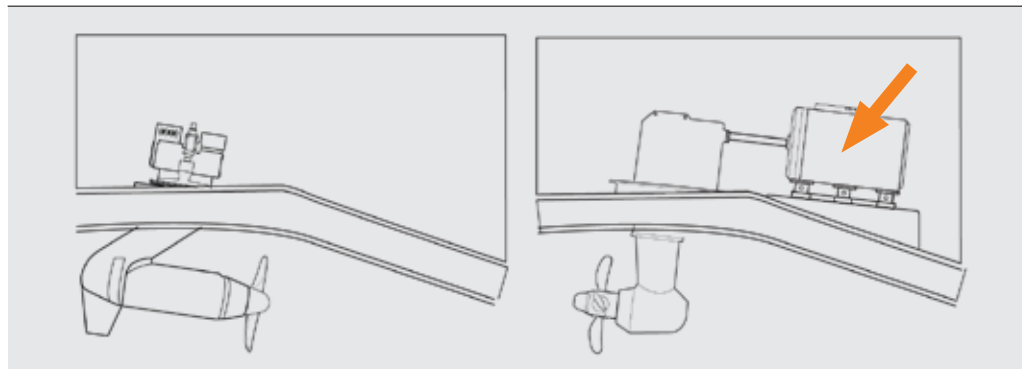

10 Three Azipod CO propulsors in a pulling arrangement

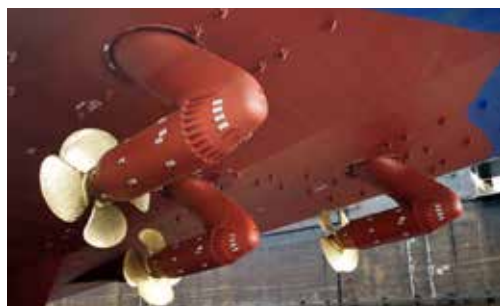

The excellent reliability and simple robust design also have a significant impact on the maintenance costs of the Azipod C propulsor. With fewer critical components on the drivetrain, there is less unexpected downtime due to fewer potential components to fail. There are also fewer components to be inspected and maintained during overhauls.

#### More payload

A smaller footprint is an advantage for any onboard equipment, especially with small compact vessels such as anchor handlers, offshore supply and construction vessels and, even more so, in ferries and yachts. The beauty of the Azipod propulsor is that the large propulsion motor is placed underwater, next to the propeller, saving valuable onboard space.

The saved onboard space is typically used to:

- Get more payload
- Change machinery layout to reduce the vessel's overall length
- Optimize hull lines to reduce hull resistance

The above possibilities improve the operational profitability of the vessels by improving payload and lowering fuel consumption.

#### Conclusion

Since 2000, experience has verified the inherent benefits of the gearless podded design with regards to efficiency, reliability and space savings. Further advantages of the Azipod C propulsor include, for example, a permanent magnet motor and simple auxiliary systems.

The combined annual fuel cost savings, including improvements in hydrodynamic, mechanical and electrical efficiencies, can be realistically estimated to be from 10 to 30 percent, compared with conventional geared azimuthing propulsor.

The excellent reliability of the gearless design has been demonstrated by over 2 million accumulated running hours with Azipod C propulsors. Long service intervals and excellent reliability improve savings from maintenance and out-of-operation costs for operators and owners.

#### Kimmo Kokkila

Product manager, propulsion products,  
ABB Marine & Cranes, Finland  
kimmo.kokkila@fi.abb.com

# Azipod® propulsion ideal for ice management

**JUKKA VARIS, SAMULI HANNINEN, TORSTEN HEIDEMAN, OLLI TOIVANEN – A major part of the world's oil and gas reserves are located in Arctic and sub-Arctic seas, such as the Sakhalin fields in the Okhotsk Sea, as well in the Chukchi and Beaufort Seas off Alaska. Year-round operations in these areas result in increasing need for specially designed icebreaking offshore support vessels and tankers. An important characteristic of these vessels is their ice management capabilities.**

**A**zimuth thrusters offer great flexibility in different ice management situations by using the thruster wake and propeller in close contact with the ice. Electric propulsion with Azipod propulsors has been successfully used with such vessels for many years, and the system itself has proved reliable when operating in ice. In the Sakhalin region, experience has accumulated from using seven icebreaking vessels with ABB electric propulsion, many equipped with Azipods. Recently, two new Azipod icebreaking vessels have been built for the Arkutun-Dagi field.

Electric Azipod propulsion systems have been playing an important part in making several demanding Arctic shipping projects technically and economically feasible. In this article we will present the characteristics Azipod propulsion as well as some full-scale test results from the use of Azipod units in ice management operations. These results will show how Azimuth propulsion offers improved ice management performance and greater vessel design flexibility. They will also offer further insight into different possibilities; for example, selection of the most suitable azimuthing angles for various tasks.

#### Azipod propulsion in icebreakers

The Azipod propulsion system enables a vessel to break ice using the revolutionary Double Acting (DA)

1 Azipod units installed on the double-acting icebreaking supply vessel SCF Sakhalin



principle, <sup>[1]</sup> Heideman et al (1996). The DA principle means that the vessel can be designed with the stern optimized for icebreaking and the bow optimized for another condition such as a bulbous bow for open water or a heavily ice-strengthened bow for multi-year icebreaking by repeated ramming. It is well known that when going astern, the ice resistance of a ship will decrease as a result of the propeller flow around the aft part of the hull, which, among other factors, reduces friction. However, ships equipped with conventional rudders are difficult to steer when going astern. This problem does not affect ships equipped with an Azipod system, as the propeller thrust can be steered in any direction (see Figure 1).

The Azipod system greatly improves the maneuverability of ice-going vessels. The turning unit allows the propeller thrust and wake to be directed against the ice, meaning it can be effectively used in ice management tasks such as <sup>[2]</sup>:

- Breaking the vessel through ice ridges
- Vessel operation in ice rubble
- Clearing a wide channel behind the vessel
- Clearing ice around the hull of the vessel or from a structure or platform
- Breaking level ice or pack ice to smaller pieces
- Clearing ice between the pier and the ship

This paper will explain how the correct operation of an azimuth thruster can further enhance each of these ice management tasks. Differences in ice management tasks in various ice-covered seas will be discussed.

Full-scale ice management tests and measurements recently carried out onboard an icebreaker will also be summarized.

### Ice management (IM)

What do we mean by ice management? How can we define it? Players in the industry have different perceptions of what it is depending on their own experience. We will briefly go through IM in different areas in the world and highlight what is required from the vessels that operate in those areas.

#### Sakhalin

In the Sakhalin area, IM used to be closely connected to the Sakhalin II project and the Molikpaq platform in the 1990s. Offloading from Molikpaq was via a SALM (single anchor leg mooring) buoy and a floating storage and offloading unit (FSO) named Okha. Both the SALM and the FSO were moderately ice strengthened and the operating window was very dependent on effective IM. The area consists of drifting sea ice of varying thickness with occasional stamukhas or parts of them. A stamukha is an ice feature that has been grounded and grown in size due to rafting. Storms and high tides can push it back into the sea, where it starts to drift with the pack ice. In this area ice concentration is normally well below 1 (10/10).

The supply vessels expanded the operating window for the SALM, Okha and the offloading tanker by

positioning themselves upstream in the ice flow and creating an ice-free path by turning the thrusters more or less transversely and then pushing the ice to the sides using the propeller wash. In this kind of operation the force and the direction of the propeller wash stream are important and this should be reflected in the design of the propulsion arrangement.

Nowadays, this mode of operation is no longer needed since offloading from the Molikpaq platform is by pipeline to the shore. IM tasks are now mostly to clear ice away from loading and manifold areas and to keep the rescue area, where the emergency escape capsules descend, clear of ice. These tasks are better performed by milling the ice with the propellers. It is important to understand that the gravity-based platforms do not need IM to survive because they are designed to withstand all ice loads.

#### Baltic Sea

IM is quite different in the Baltic and other sub-Arctic areas. Here we generally speak about assisting and convoying merchant vessels. When an icebreaker frees a vessel in compressed ice, the ice milling effect of the azimuthing thrusters can be fully utilized. On the other hand, during vessel convoying, the flushing effect from the transverse thrusterwash can be used to clear the channel and reduce the required power outtake of the vessels that follow, thereby saving fuel and reducing emissions. These are design points for assisting icebreakers.

#### Caspian Sea

The ice conditions in the Caspian Sea are highly dynamic. Outside of the landfast ice, the ice is constantly moving, rafting and ridging. This, in combination with very shallow water in the northeastern part of the Caspian, produces grounded ridges that reach high above the water level. In these conditions, the only way to operate is to mill the ridges with propellers and remove the milled ice with the propeller wash. This is how the supply vessels manage the ice at the Kashagan site when they clear the loading and escape areas.

#### Arctic waters, North America

IM performed in North America is, again, completely different from that described above. On the east coast, in the Labrador Sea between Newfoundland

and Greenland, IM means mainly iceberg towing in more or less open water during the summer season. This kind of operation requires different capabilities from vessels. Azimuthing thrusters offer excellent maneuverability and are able to manage growlers and bergy bits using the directed propeller wash effect. If the thrusters are equipped with nozzles, they protect the propellers against towing wires in the sea to a certain extent. It is a common misperception that iceberg towing requires very high bollard pull force. As a matter of fact, iceberg towing is normally performed using low speeds and pull forces – normally less than 100 tons – to prevent the iceberg from tumbling over.

IM on the North Slope in the Beaufort Sea is more violent than anywhere else in the world. Here the focus is on protecting exploration vessels from drifting pack ice that contains multi-year (MY) ice. There are several IM techniques, some involving several vessels with different roles. However, all the vessels used for IM have a high ice class in common and they are usually equipped with very strong bows intended for breaking the MY floes by repeated ramming. When operating in MY ice conditions, great care should be taken when rudders and propellers or azimuthing thrusters come into contact with the ice. With MY ice, the main mode of operation is bow first.

#### Russian Arctic

There are also different kinds of IM in the Russian Arctic. In the waters to the west of Kara Gate there is an established shuttle tanker service system and another ready to start up any day. Here the IM vessels are supposed to prepare the offloading site before the tankers arrive and help them maintain the correct position with respect to the ice drift direction during offloading. During operations, both flushing, milling and breaking bow-first have been used. In the high Russian Arctic to the east of Kara Gates, IM mostly involves convoying vessels through the ice. Nuclear icebreakers normally break a lead through the ice ahead of the convoy. The reason for the large distance between the icebreaker and the convoy is safety related. The ships following the icebreaker need a proper stopping distance in case the icebreaker is stopped by severe ice. If the vessel(s) cannot follow, the icebreaker returns to free the vessel by maneuvering close to the stuck vessel, thereby releasing the ice pressure on the hull.

2 *Aleksey Chirikov* during sea trials



IM is thus not a clearly defined function but various tasks involving milling or flushing with the propellers or managing the ice by breaking it with the bow. Different IM tasks require different capabilities from the IM vessels. Elegant vessel designs can produce compromises that work reasonably well for several IM tasks.

#### Full-scale IM tests on board the icebreaking PSV *Aleksey Chirikov*

*Aleksey Chirikov* is an icebreaking platform supply vessel built by Arctech Helsinki Shipyard for Sovcomflot. The vessel's main features are summarized in the table below. Figure 2 is a photograph of the vessel taken during sea trials.

Table 1. IBPSV *Aleksey Chirikov* main parameters

LOA	99.9 m
DWT	3950 t
Breadth	21.7 m
Propulsion	2 x ABB Azipod VI1600 total 13 MW

Sea trials were conducted with the *Aleksey Chirikov* in March 2013 in the Gulf of Finland. In between the standard sea trial program, tests were conducted to study the propulsion system's response to various combinations of propulsion power and azimuth angles.

Tests were conducted by measuring vibrations from Azipods while constant power and azimuth angle was maintained. Increasing the azimuth angle with high power increases vibrations and, at a certain angular

3 Propeller wake with 45° azimuth



4 Azipod toe-in position ("pulling mode")

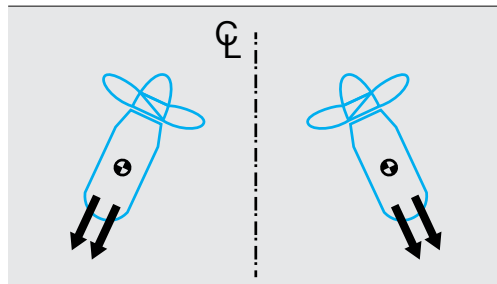

5 Propeller wake with 90° azimuth

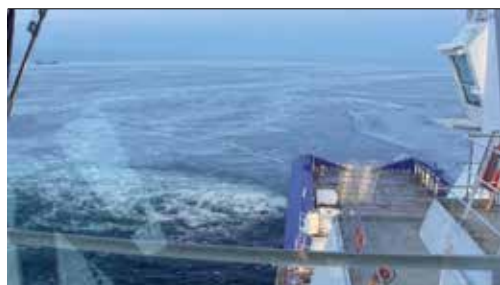

6 Azipods turned 90° in reverse rpm rotation ("pushing mode")

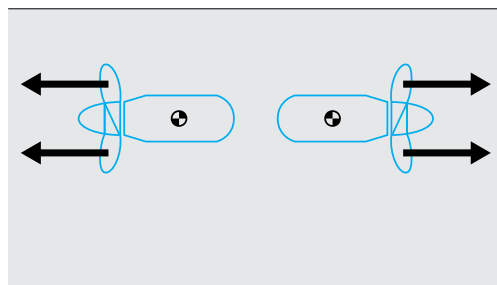

zone, it is advisable to avoid continuous high power to prevent unnecessary loading of the machinery. It is worth noting that the Azipod system, being simple and robust, has considerable tolerance against vibration, especially when compared with systems with a more complex mechanical power train. However, it is only prudent to take means to lessen vibrations, if this can be done while performing all tasks.

Vibration levels depend not only on power, but also on the speed and direction of motion as well as the geometry of the ship's hull and propulsion system. All possible combinations were not tested due to limited time allocated to the test. Hence, all tests were carried out only in ahead motion (positive rpm in "pulling mode"), in light ice and sea conditions.

In the first test Azipods were gradually turned to toe-in position (see Figure 4) while maintaining high power. In second test, Azipods were turned 90° outward, producing no net thrust (Figure 5 and Figure 6). Power was increased step by step, up to maximum power. In the third test, the azimuth angle was gradually lessened.

During the last tests (see Figure 5), with a reverse direction of rotation of the propellers ("pushing mode"), the behavior was somewhat different because the propeller geometry was different. Also, during this last test the propellers started to cavitate slightly before full power was reached. This was due to the fact that propellers were optimized for forward speed bollard pull.

Generally, the vibration levels during the tests remained moderate. While the tests were conducted only in the vessel's ahead motion, the author's impression is that an astern operation would make such IM operations even smoother. The Azipod's mechanical design allows the reverse propeller rotation "pushing mode" (Figure 6) without power or torque limitations. Therefore, if needed for vessel operations, the propellers can be designed to absorb full power without limitation in both "pulling" and "pushing" mode during IM duties.

Results of these full-scale tests can be used to draw up new guidelines for the design of Azipod-propelled vessels, that are to have IM duties, to maximize their

7 Areas of Azipod measurement instrumentation, Nieminen (2005)

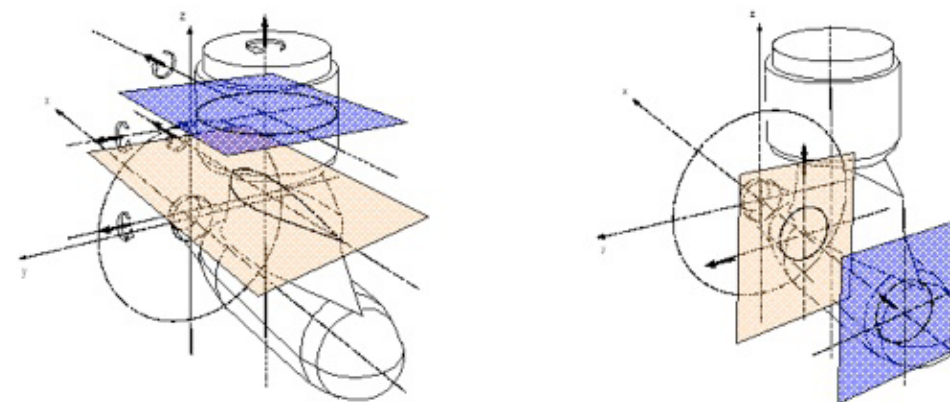

8 a) FESCO Sakhalin in operation close to platform b) Azipod global ice load as a function of azimuth angle (Nieminen, 2008)

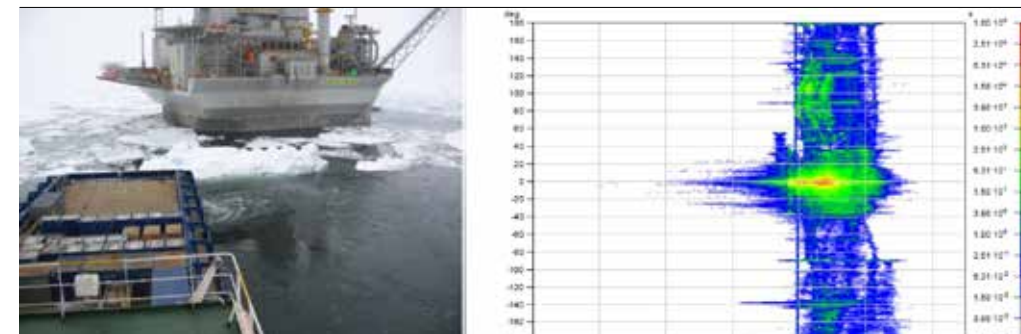

IM effect while maintaining long and reliable service life of the relevant machinery.

#### Azipod ice load measurements on board the FESCO Sakhalin

The measuring system for ice loads on the propulsor for this icebreaker was installed in 2005 during the building stage and the long-term measurements were carried out until 2008. The system measures ice loads on the body of the Azipod propulsor on the shaft bearings. Today the vessel operates under the name SCF Sakhalin.

#### Azipod instrumentation

The loads on the thruster body were measured by strain gauges attached in two different cross sections to the inner structures of the upper part of Azipod. These locations were defined based on stress

distribution on the Azipod structure for load cases where longitudinal, transverse and torsion loads were applied at the potential locations of ice loads. The instrumented areas inside the Azipod are shown in Figure 7.

The propeller-bearing loads and the thrust were also measured by strains at the lower part of the Azipod. The propeller bearing loads were measured with strain gauges attached at the supporting structure near the bearing. Strain gauges for the thrust were located at the longitudinal stiffener near the thrust bearing. The instrumented areas in the Azipod shaft line structure are also shown in Figure 7.

The relative shaft line movements were measured with displacement transducers attached close to the bearing housings. The dynamic behavior of the



lower body was measured by tri-axial accelerometers located in both bearing housings. Some accelerometers were also attached outside the Azipod in the Azipod room. The hydraulic pressures of the steering motors were measured in order to determine the torque of the steering motors. The ship's status and environmental conditions were ascertained directly from data in digital format provided by ABB's and ship's systems. The measuring signals were transmitted from the turning part of the Azipod by a wireless data link. In total, 53 different signals were recorded, Nieminen (2005) [9].

### Azipod ice-load measurement results

Azipod ice load data was collected during normal ship operations over four years. The operations consisted mainly of stand-by and IM close to the Orlan platform (Figure 8a) as well as transit voyages from the platform to the port of Khlomsk.

The measured and analyzed data provides insight into loads in different operational modes and it has been very useful in verifying dimensioning criteria as well as developing Azipod systems for the new type of icebreakers. Some of the major classification societies have been very interested in the results when developing and upgrading their ice rules.

Figure 8b shows global ice loads as a function of the azimuth angle.

To sum up, different IM tasks require different capabilities from the icebreaker. However, elegant vessel designs and the correct selection of propulsion system can produce solutions that work reasonably well for several IM tasks.

#### Jukka Varis

Vice president

Technology & Business Development, ABB, Marine United States

jukka.varis@us.abb.com

#### Samuli Hanninen

Area Sales Manager, ABB Marine, Finland

samuli.hanninen@fi.abb.com

#### Torsten Heideman

Senior Engineer, ABB Marine, Finland

torsten.heideman@fi.abb.com

#### Olli Toivanen

Lead Engineer, ABB Marine, Finland

olli.toivanen@fi.abb.com

#### Notes

1. Heideman, T. et al (1996). Full-scale ice trials in ridges with the Azipod Tanker Lunni in Bay of Bothnia in 1996. Polartech'96.
2. Keinonen, A. (2008). Ice Management for Ice Offshore. Arctic Passion Seminar, March 6, 2008, Helsinki, Finland.
3. Nieminen, V. (2005). Ice Load Measuring System of Azipod Propulsion Unit of IB FESCO Sakhalin; Instrumentation and Calibration. VTT research report TU57-055933 (Confidential).

#### References

- Hanninen, S., Heideman T., Toivanen, O. (2014). *Results Using Azipod Propulsion in Ice Management Operations*. OTC24631, Houston.
- Nieminen, V. (2008). *Ice Loads on the Azipod Propulsion unit of IBSV FESCO Sakhalin*. VTT research report VTT-R-07784-07 (Confidential).

# Onboard DC Grid – one year in operation

**ISMIR FAZLAGIC, JAN-FREDRIK HANSEN, ALF KÅRE ÅDNANES** – In 2010 ABB presented the concept of Onboard DC Grid as a revolutionary solution that uses a DC as the media for transmitting electric power between the prime movers, thrusters and propulsors, and other onboard consumers. The expected space and weight saving, and improved fuel efficiency was based on theoretical analysis and testing in a laboratory environment. Now that the first installation has been in operation for more than a year, we have a good understanding of the real-life performance of Onboard DC Grid.

The Onboard DC Grid concept was described in Generations 2012, and is based on a principle where the output of the AC generators is rectified before connecting to the common DC distribution system. The DC distribution enables for using bus ducts to transmit even high power levels, without the use of a main AC switchboard and drive transformers.

Advantages of DC distribution, in certain cases, include lower overall losses and fewer problems with harmonic distortion. Yet historically there have been challenges with DC distribution, primarily revolving around how full selectivity and equipment protection can be achieved in ways that are similar to AC distribution. AC currents are by nature simpler to interrupt because of their natural zero crossing every half cycle.

## 1 The Onboard DC Grid concept



ABB overcame these challenges by breaking with the classic protection philosophy, where selectivity is achieved through an arrangement of coordinated circuit breakers, and instead capitalizing on the opportunities afforded by power electronic components in the onboard DC grid system.

### Power distribution and configurations

In traditional electrical propulsion systems, variable frequency drives typically account for more than 80 percent of the installed power. At its simplest level, the Onboard DC grid is a reworked and distributed multi-drive system (Figure 1).

The solution merges the various DC links around the vessel and distributes power through a single 1,000V DC circuit, thereby eliminating the need for main AC switchboards, and converter transformers. All electric power generated is fed either directly or via a rectifier into a common DC bus that distributes the electrical energy to the onboard consumers. Each main consumer is then fed by a separate inverter unit.

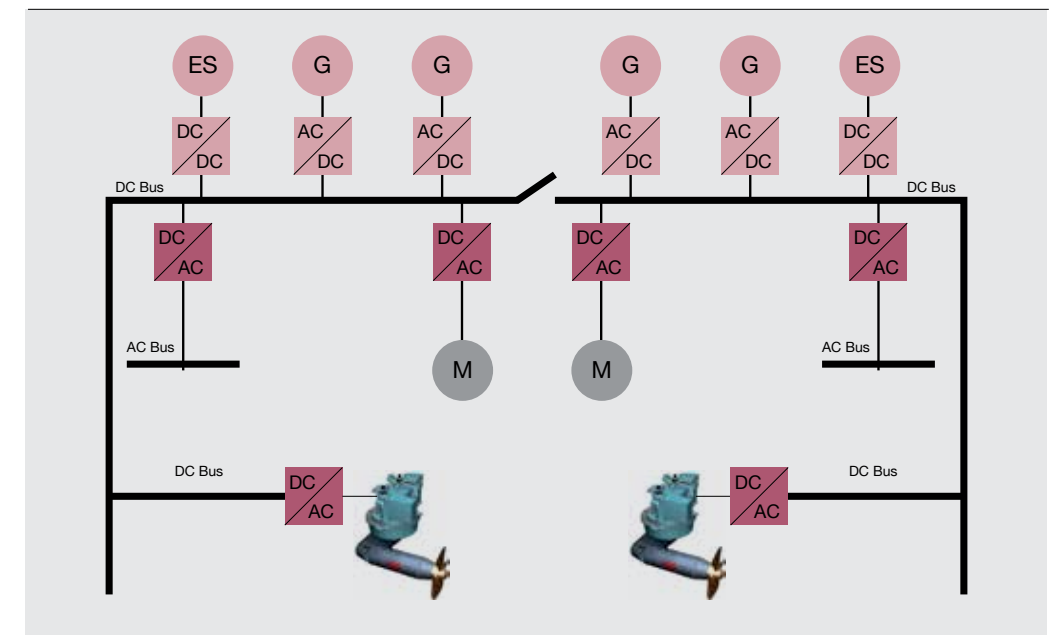
As the DC only couples the various energy sources through a common voltage, the generators do not need to be synchronized and may even operate at different frequencies. It is also simple to connect energy sources with DC output to the DC distribution without concern about frequency conversion or synchronization. This allows for easy adaptation of batteries and super capacitors to the power system, which will enhance energy efficiency for many vessel types and operations.

When an AC distribution network is still needed, for example with a 230V hotel load, it is fed using island converters developed by ABB to feed clean power to these more sensitive circuits. Additional converters for energy storage, in the form of batteries or super capacitors for leveling out power variations, can be added to the DC grid.

### Variable speed diesel engines

AC-based diesel electric propulsion technology has a high overall efficiency, above 90% in the electrical grid, but only allows engines to be operated at one fixed speed, due to a determined constant frequency. The engines have an overall efficiency of around 45–50 percent, and the most optimal fuel operational

window is between 75 and 85 percent. In order to improve the environmental conditions and reduce fuel costs during low load conditions, variable speed operation of engines needs to be looked into.

ABB's Onboard DC Grid technology allows variable speed operation of engines, which traditionally have been run in constant speed to maintain a constant frequency, regardless of power demand. The newly developed technology not only allows variable speed operation but, due to a DC-based distribution, bulky electrical equipment can be eliminated. All this has many positive effects for the shipowner and crew. Most notable are a large reduction in noise and vibration, increased SCR effectiveness, longer runtime between service, less wear, reduced consumption of lubrication oil, reduced operational and maintenance costs and a notable reduction in fuel costs.

### Pilot Installation

ABB delivered the first Onboard DC Grid system to MS Dina Star, owned by Myklebusthaug Management in Norway. Pon Power delivered the 4 x 3516C main engines and 1 x C32 harbor generator for the ship.

This article will further review the differences in fuel consumption and noise reduction for a variable speed system (1200–1,800 rpm) compared with the same system run in fixed speed at 1,800 RPM with load steps and varying loads.

Making a direct comparison between a fixed speed engine and a variable speed propeller engine is difficult when measuring on two separate ships because it is near impossible to achieve identical conditions. Thus, the comparison in this report is between a CAT 3516C propeller engine, rated at 2350 bkW, running in variable speed at 1,200–1,800 RPM and the same engine locked in fixed speed at 1,800 RPM.

The fuel measurements were performed in cooperation with Pon Power AS, Denmark. Tests were performed on a voyage from Peterhead, Scotland to Haugesund, Norway between May 18 and 19, 2014.

### Testing description

The main goal was to understand the performance of operating engines at variable speeds of 1,200–1,800 RPM compared with fixed speed at 1800 RPM.

## 2 Two SFOC curves for variable and fixed speed 10 percent load steps

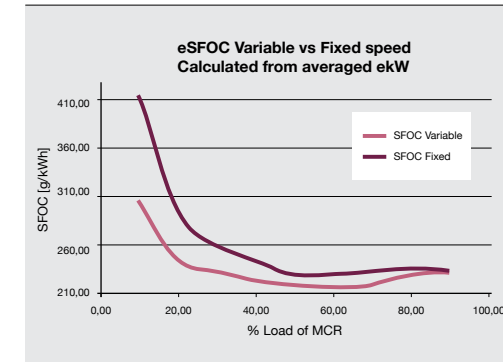

The results presented in this article are from two tests:

1. DP (Dynamic Positioning) Operational fuel measurement test – the objective was to verify differences in fuel consumption during a real world vessel operation running at variable and fixed speed.
2. Load step fuel measurement test – the objective was to verify difference in fuel consumption at stable load levels of 10 percent increments.

### DP Operation fuel measurement test

It was decided to execute a DP mode test with fluctuating loads. The DP operation was deemed the most relevant to execute, as transit, harbor and other operational modes do have a more or less constant load. To show fuel savings in a varying load scenario, a test was done in DP mode on a single engine. Fuel was only measured on a single engine, but two engines were running to keep the position accordingly.

First, the engine was run at variable speed for 45 minutes and then for 45 minutes at constant speed. The PEMS (Power and Energy Management System) data were used to compare time, fuel, power and RPM data. The power was integrated over the time period for the variable speed test and the produced energy in kWh and fuel consumption was calculated.

For the constant speed test, the power was also integrated and the fuel consumption noted at the time when the produced energy was the same as the energy produced during the variable speed test. This makes the results directly and academically comparable.

## 3 Fuel savings (variable vs fixed) – power trend line added

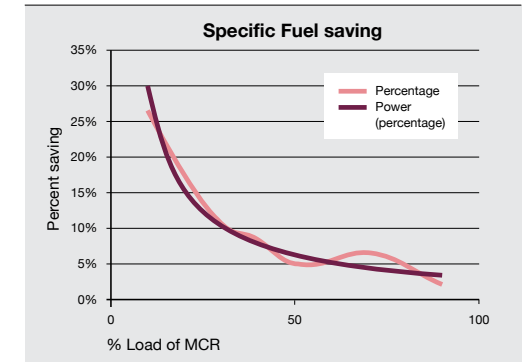

### Load step fuel measurement

The purpose of this test was to show the fuel consumption under a stable load, the effectiveness of the SCR system and effect on engine room noise level. This load test was performed with 10 percent load interval from 10 percent to 90 percent.

The engine was run first in variable speed with asymmetric load sharing to a fixed load from 10–90 percent. The load fluctuated slightly and the burn rate fluctuated accordingly within a few liters/hour. The ship hitting a wave would cause the burn rate to momentarily go up and then settle again. The mean burn rate value was logged during the test procedure, and is later presented in the result section. Only one value was noted for each load level.

Exhaust temperature and sound level were also noted during each load step.

### Results

The performed tests demonstrated advantages in all aspects when running engines in variable speed mode. Both the 10 percent load step test and the varying load test showed lower fuel consumption for variable speed operation.

The lower load range in particular showed fuel savings of up to 27 percent at lowest load, a decrease in sound pressure level of 5 dB from 1200 to 1800 RPM, which equates a reduction in engine noise loudness of around 30 percent, and an increased effectiveness of the SCR system to include the whole tested operational range from at least 10–90 percent load.

#### 4 Variable speed load steps

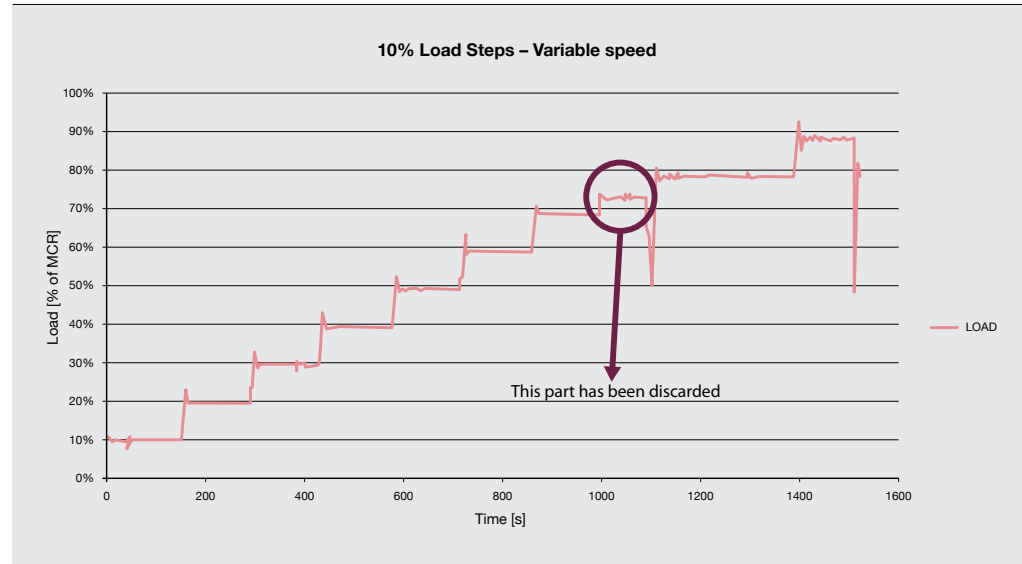

#### 5 Fixed speed load steps

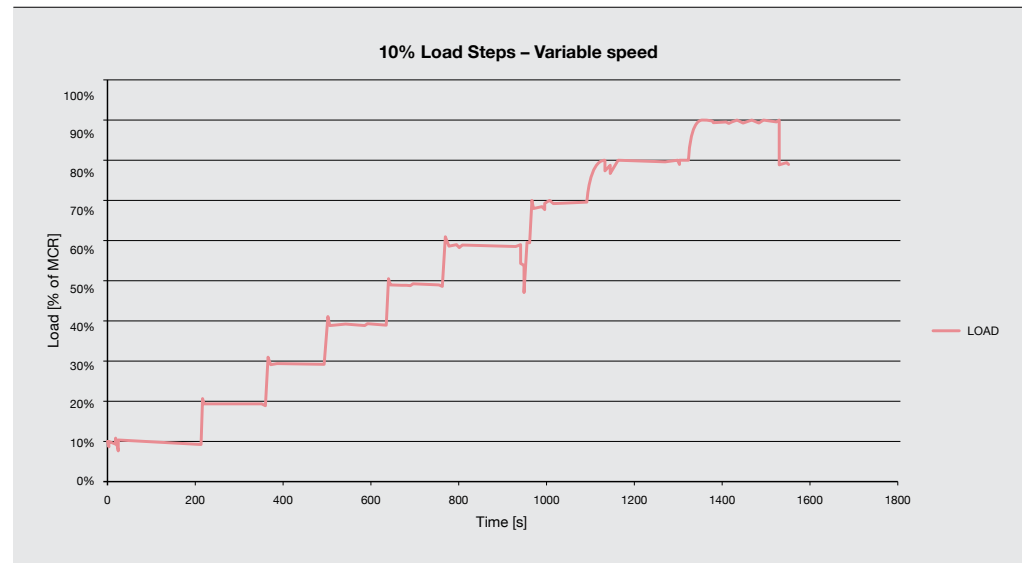

#### Test 1: 10 percent load step test results

The 10 percent load step test showed impressive results, where a fuel reduction of up to 30 percent was shown when variable speed operation was allowed. Figure 2 shows the specific fuel oil consumption results of the 10 percent load step. The graph shows and represents the results from CAT fuel flow meters over average electrical power.

Figure 2 shows and summarizes specific fuel consumption for variable speed and fixed speed through the entire load range the engine is able to carry.

Figure 3 shows and summarizes the fuel savings for variable speed and fixed speed through the entire load range the engine is able to carry.

#### 6 Variable speed DP load/RPM/fuel trend

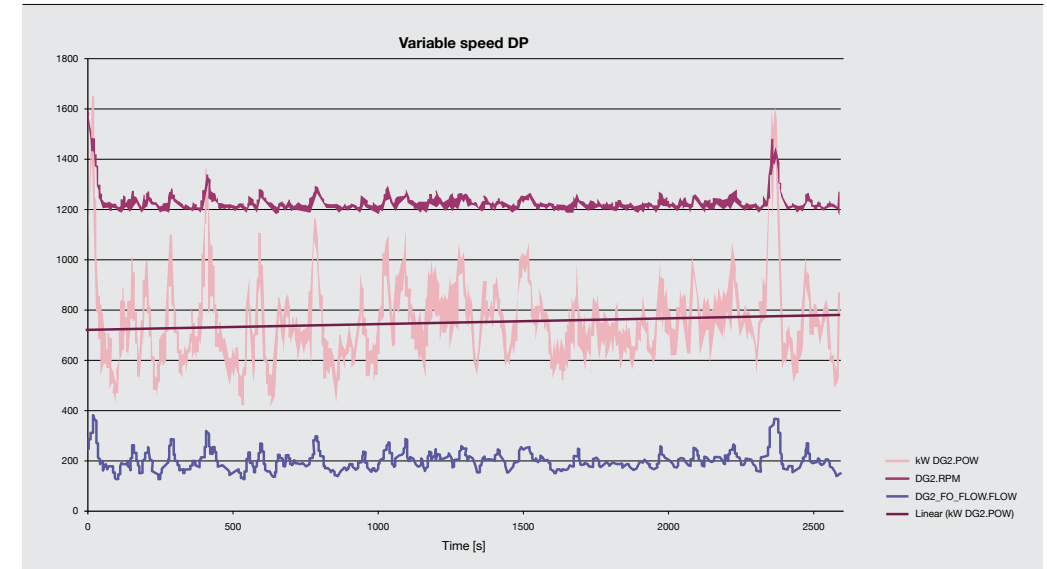

Figures 4 and 5 show the load applied when both variable and fixed speed operations were executed with 10 percent load step increase.

As shown in Figure 4, there was a step at 73 percent load. This has been removed from the values used in the SFOC curve. It was caused by a disproportionate number of engines running compared to the load demand when the load step was switched to 80 percent and an engine had to be shut down to allow 80 percent load on the tested engine.

#### Test 2: Varying load test – DP mode

The DP test lasted 45 minutes and was run first at variable speed and then at fixed speed at 1,800 RPM. Both tests were run on the same engine. The ship was turned so that the weather conditions would give the most load variations when keeping the ship in position. The two tests were performed over 90 minutes and weather conditions were as follows:  
 Wind speed: 15–22 m/s  
 Wave high: 2–3 m

The raw data were divided into separate spreadsheets, variable and fixed speed. Time was converted into a second format, starting from 0, counting approximately 1.04 seconds between each logging. Seconds were logged with 3 decimal points, giving

a resolution of milliseconds. The power was then integrated for the whole duration, leaving a column with the total produced energy at each logging. That way it was possible to see produced energy and fuel consumption at any point during the test. The total energy production for the variable speed DP test was 558.51 kWh and there was a fuel consumption of 144 liters (see Figure 6).

The same test was then repeated with the diesel engine in fixed speed mode. Figure 7 compares the logged energy production and fuel consumption in the two modes, variable and fixed RPM. As seen, the produced energy is slightly higher in fixed RPM mode, likely due to differences in the transient behavior of the engine in the two modes. However, the difference also reflects the real difference between the two modes and is thus relevant for the comparison.

The results are presented in Table 1; showing that for the comparable time period of the same test procedure, the fuel consumption over the whole test cycle is reduced by 13.77 percent when allowing the engines to optimize the RPM for the varying loads.

#### Conclusion

In the 10 percent load step test, the results show a 27 percent fuel saving at 10 percent load down to



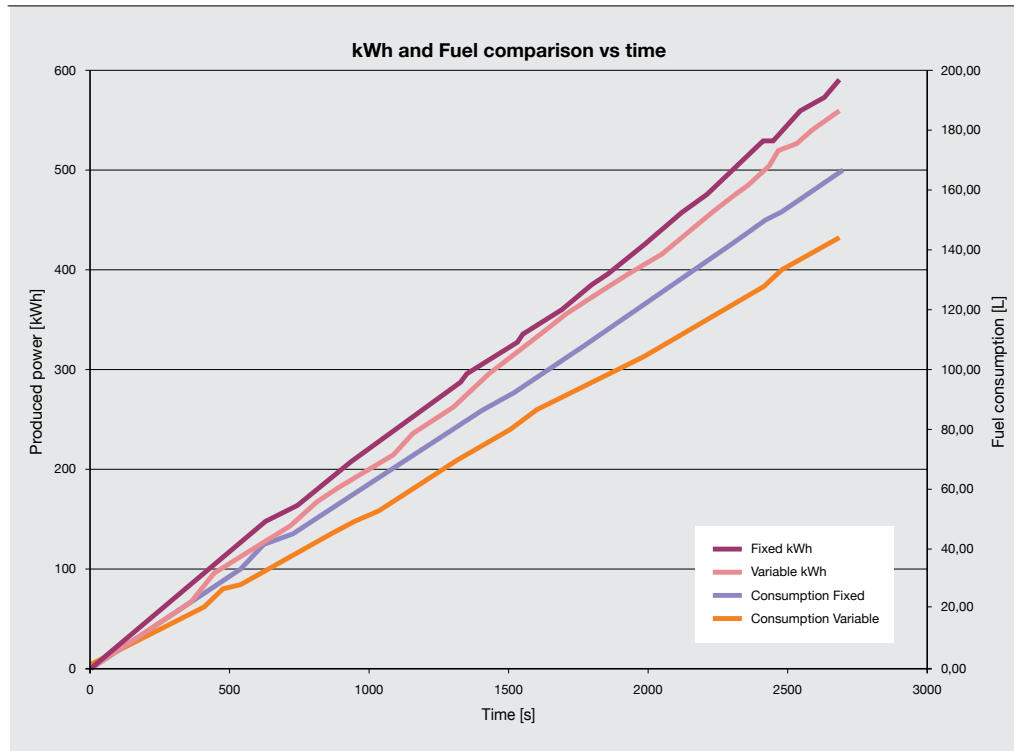

Table 1

Test	Produced energy	Consumed fuel	Fuel saving	Run time [s]
variable speed test run	558,51 kWh	144 L		2683
Fixed speed test at same produced energy as var.	558,46kWh	158 L	$(158-144)/158*100 = 8,86\%$	2549
Flxed speed - Time equal to variable speed test run	589,14 kWh	167 L	$(167-144)/167*100 = 13,77\%$	2683

3,5 percent fuel saving at 80 percent load when running the engine at variable speed from 1,200 to 1,800 RPM.

In the varying load DP test, when comparing the consumed fuel in the DP test for the same time period, the result is between 9 percent and 14 percent for variable speed depending on the comparison type. It is important to highlight the difficulties in achieving exact identical conditions during a real world test. However, the two tests give a result between 9 and 14 percent, which is in line with or even exceeds the theoretical expected figures for this operation mode.

**Ismir Fazlagic**  
Global Product & Solutions Manager  
ABB Marine, Norway  
ismir.fazlagic@no.abb.com

**Jan-Fredrik Hansen**  
Technology Manager  
Centre of Excellence Oil & Gas Vessels, ABB Marine, Norway  
jan-fredrik.hansen@no.abb.com

**Alf Kåre Ådnanes**  
Vice president, local business unit manager, Marine & Cranes, Singapore  
alfkare.adnanes@sg.abb.com

# Optimizing the design and power management strategy of tugs with Onboard DC Grid

JASPREET SINGH DHUPIA, AARON ALEXANDER AYU, THANH LONG VU – Nanyang Technological University in Singapore has partnered with ABB Singapore to investigate the optimal design of and power management strategy for harbor tugs that have ABB’s Onboard DC Grid installed.

Harbor or terminal tugs are excellent candidates to achieve significant reduction in costs, pollutants and fuel consumption through electrification. This is because traditional diesel tugs have engines sized for full bollard pull, which is used for only around 7 percent of the time. For most of the operation time, the main engines are operated in idling mode. *Carloyn Dorothy*, built in 2009, now operating in the ports of Long Beach and Los Angeles, was the first practical demonstration of electric tugs. However, as pointed out by experts, the transformation of the industry to electric/hybrid vessels will not take place overnight and requires research and development to get the full value of additional cost investments made in ship design, equipment and construction. This requires funding, but prototype construction is a sticking point for most tug owners. Therefore, Nanyang Technological University has partnered with ABB Pte. (Singapore) Ltd. to analyze the design of harbor tugs equipped with the Onboard DC Grid, mathematically model them and simulate their response

in a MATLAB/Simulink software environment. The purpose of this investigation was:

1. To investigate the ideal investment in equipment and design of harbor tugs equipped with Onboard DC Grid in order to provide a return on investments through fuel and operational cost savings within a fixed time horizon.
2. To find the power management schedule of diesel engines and batteries for a given design of harbor tug equipped with Onboard DC Grid that achieved the maximum operating cost savings.

This article describes the modeling strategy overview used to develop the programmed mathematical model in MATLAB/Simulink, which is later used to investigate both the ideal design and optimal power management strategy. The mathematical model accounts for response of components such as diesel engine generators and batteries to meet the load demand. This model is later used, with the optimization toolbox available in MATLAB/Simulink, to

1 Schematic of power distribution system of a tug equipped with Onboard DC grid

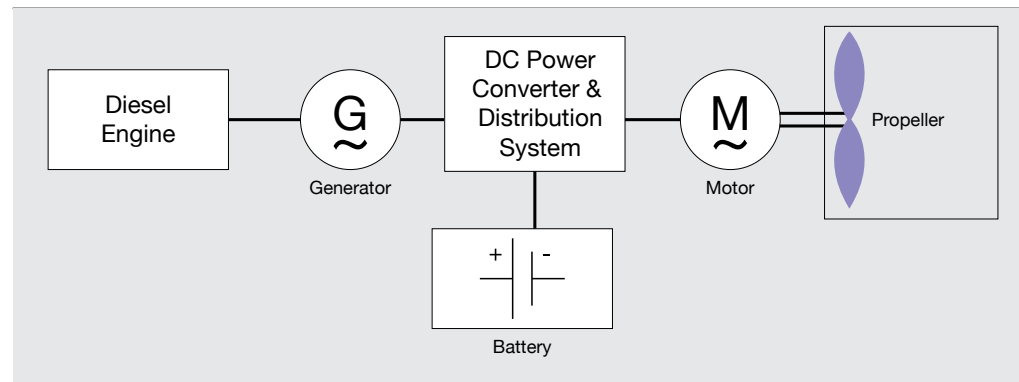

2 Simulink model for power distribution system of a tug equipped with Onboard DC grid

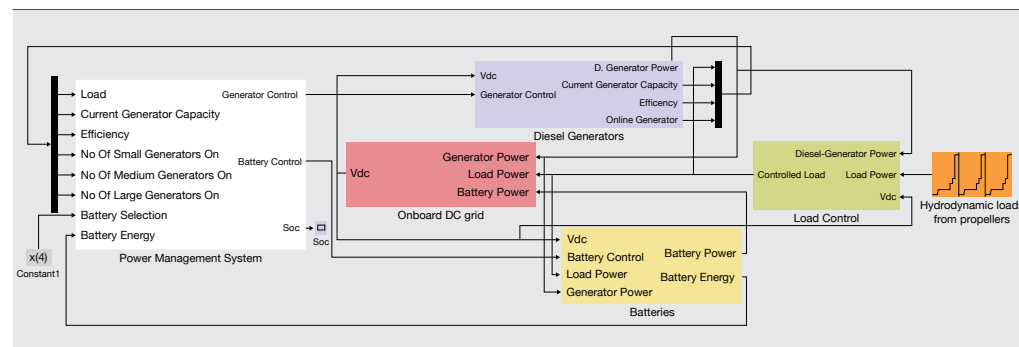

evaluate the optimal solution to both the ideal design and power management strategy problem, and the key conclusions are presented.

The solution of the optimal design formulation recommends that a tug equipped with Onboard DC Grid can provide a return on investment within five years. Significant fuel savings are achieved using the Onboard DC Grid configuration over the traditional mechanical configuration. The optimal solution recommends using both batteries, as well as multiple smaller sized diesel engine generators, instead of a single large diesel engine generator used on a purely mechanical tug. However, the battery size recommended is much smaller, compared with the installed diesel engine capacity, indicating that most of the benefits associated with hybrid battery/engine configuration can be achieved through a relatively small investment in the batteries. The schedule of engines and batteries can be easily solved after formulating the optimal power management problem if the load demand profile is

known. However, the exact load profile is usually not known. Only the general characteristics of the load demand can be deduced based on the location and jobs serviced by the tug. A novel but simple strategy to predict the load demand from historic load measurement data and general operational characteristics of the tug is proposed. This is integrated with the optimal power management formulation to determine the schedule of engines and batteries for the Onboard DC Grid-based tug.

#### Mathematical modeling of a tug equipped with Onboard DC Grid

A schematic of the drive-train model for a tug equipped with Onboard DC Grid is shown in Figure 1. In general, a hybrid electric configuration of a tug can have several diesel engine generators and batteries connected to a DC bus that are managed by an “intelligent” distribution system regulating the power output and running the schedules of each engine and the batteries in response to the load demand.

Based on the basic architecture of the power distribution system presented in Figure 1, it is possible to program a mathematical model that simulates the response of diesel engines and generators at different levels of fidelity. For example, it can be assumed that the diesel engine generators and batteries can respond instantaneously to reach their power set-points, that is, the transient dynamics of engines and batteries are neglected. As such, this is a reasonable approximation in practical applications of electric tugboats, where the engines and batteries are controlled via their integrated controllers to reach their power set-points in seconds and milliseconds, respectively. Thus, the duration of transient response is much smaller than the working durations for the engines and batteries at each specified set-point, which can be several minutes. Figure 2 provides an overview of a relatively higher fidelity model programmed in the Simulink environment in MATLAB software, wherein the transients of diesel engines and the controller response characteristics are accounted for to provide an accurate estimate of fuel consumption, as well as loss of power at different components due to their individual efficiencies. It should be noted that the higher the fidelity of the model, the more computation power is required to evaluate the response of the system. This can become an important concern when evaluating the ideal design solution of an electric tugboat or determining the optimal power management scheme, as these problems require evaluating the response for several possible candidate scenarios. Such repeated evaluation of candidate scenarios can easily cascade the computation burden.

In the steady state model for the power distribution system, where the transient dynamics of diesel engine generators and batteries, as well as the controller response time, are neglected, the important characteristic of the system response modeled is that the power output from diesel engines and batteries must be greater than the load demand. This is necessary for the tug to fulfill the assigned job. The other aspects of the model are similarly modeled irrespective of the chosen fidelity level for the tug model. These aspects include a set of rules that determine when engines should be switch on or off and whether the batteries are in charging or discharging mode, engine-generator efficiency with respect to its

operating conditions and the load demand characteristics. Thus the aspects of the power distribution system of the Onboard DC Grid-based tug that need to be modeled for the general case shown in Figure 2 are as follows:

#### Control loop for diesel engine generator

Diesel engine generator power output is regulated by a PID controller. The control takes in the error of the DC bus voltage from the nominal bus voltage as input. Usually the dynamics of diesel engine generator are represented by a first order transfer function in Laplace domain or as a rate limiter in time domain to simulate the lag in the pickup response. Figure 3 describes the efficiency characteristics of a diesel engine. The efficiency of a generator is relatively less sensitive to changes in operating speeds and thus can be assumed as constant. Usually, marine generators can have efficiencies of around 95 percent in such operating conditions. Therefore, the overall efficiency of the engine generator set is the product of these two efficiencies. It can be seen that the engine has a sharp peak in efficiency in a narrow operating region at around 70 to 90 percent of the rated load. The hybrid tug configuration decouples the demand load with engine operation. This allows the engine to run in generally optimal conditions, which is the main reason for improvements in fuel efficiency from such systems.

#### Control loop for batteries

Marine applications usually use battery arrays or battery packs. A battery array can contain several battery packs, each of which consists of several modules. However, for improved battery life and utilization, the load is distributed equally among all battery modules, such that each of them is at the same state of charge (SOC), which is the parameter used for describing the stored energy in the batteries at a given time. The batteries assist by smoothing the power demand requirements from the diesel engine generators that allow them to operate highly efficiently. Compared with diesel engines, the batteries' response is faster and is assumed instantaneous in this work. Some power losses can occur in batteries as well, which are approximated as a quadratic function of the battery supply power. However, usually such these losses are much lower than in diesel engine generators, and may be ignored.

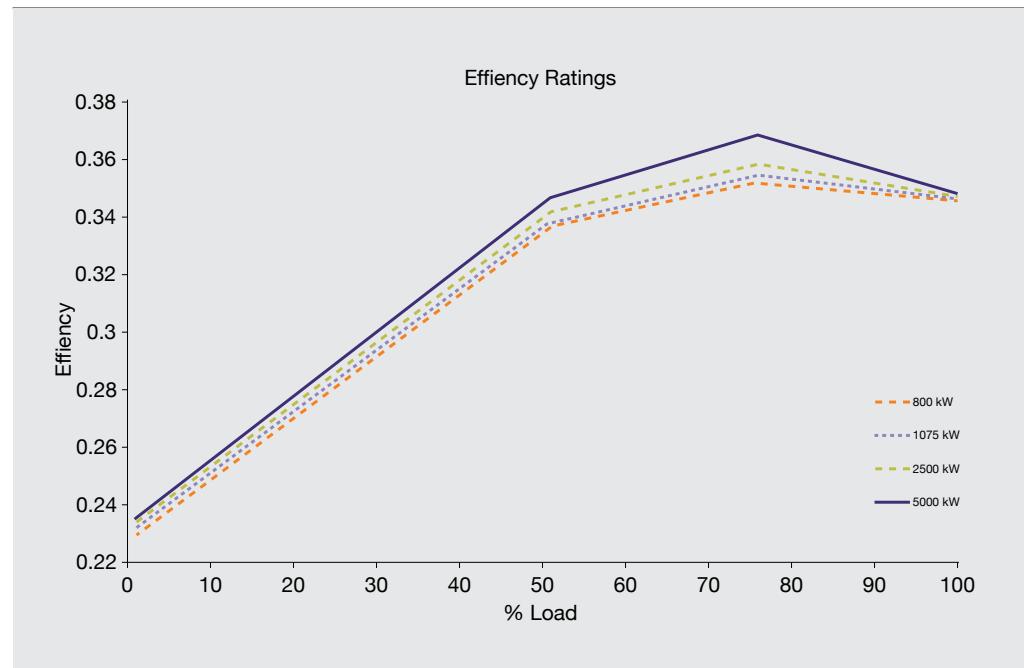

**Power management controller**

The power management controller determines when an engine needs to switch on or off, and if the batteries need to charge or discharge. Later in this article, the described model of tug equipped with Onboard DC Grid is used for evaluating the optimal design and schedule for running engines and batteries, as well as the function of the power management controller. It must be noted that, in reality, these problems are interdependent. An efficient switching strategy determined for a given design configuration will provide a better return on investment within a shorter time horizon. However, the optimal switching strategy of scheduling engines and batteries itself depends on the type and number of engines used and the total installed battery capacity. In this work, to determine the optimal design of the tug, a simple rule-based controller that aims to operate the engines under efficient operating conditions of around 75 percent rated load is used. This is done by switching on the diesel engines to meet a load demand in ascending order starting from the generator with smallest rated power. To power down of the output, a descending rule beginning from the largest generator is used. When only hotel loads are used, the diesel engines

are taken offline and the battery is discharged if sufficient charge is available in the battery.

**Load demand profile**

This work considers a typical operational load profile of a harbor tug as was provided by ABB Singapore and is presented in Figure 4. The low-load demand occurs for around 65 percent of the overall operating cycle and requires only around 10 percent of the rated power, while the medium-load demand occurs for around 20 percent of the operating cycle, requiring around 30 percent of the rated power. The high-load demand takes 15 percent of the operating cycle that requires around 90 percent of the rated power.

According to the operational characteristics of the typical harbor tugboat, this work assumes a tug subject to the load profile depicted in Figure 5. The rationale for the chosen load profile is that when the job is first assigned, the tugboat needs to be driven to reach the target and thus is in the loitering/slow steam mode. After reaching the designated work area, the tugboat waits for some time before starting its task, during which the auxiliary systems will continue to run. The power requirements during

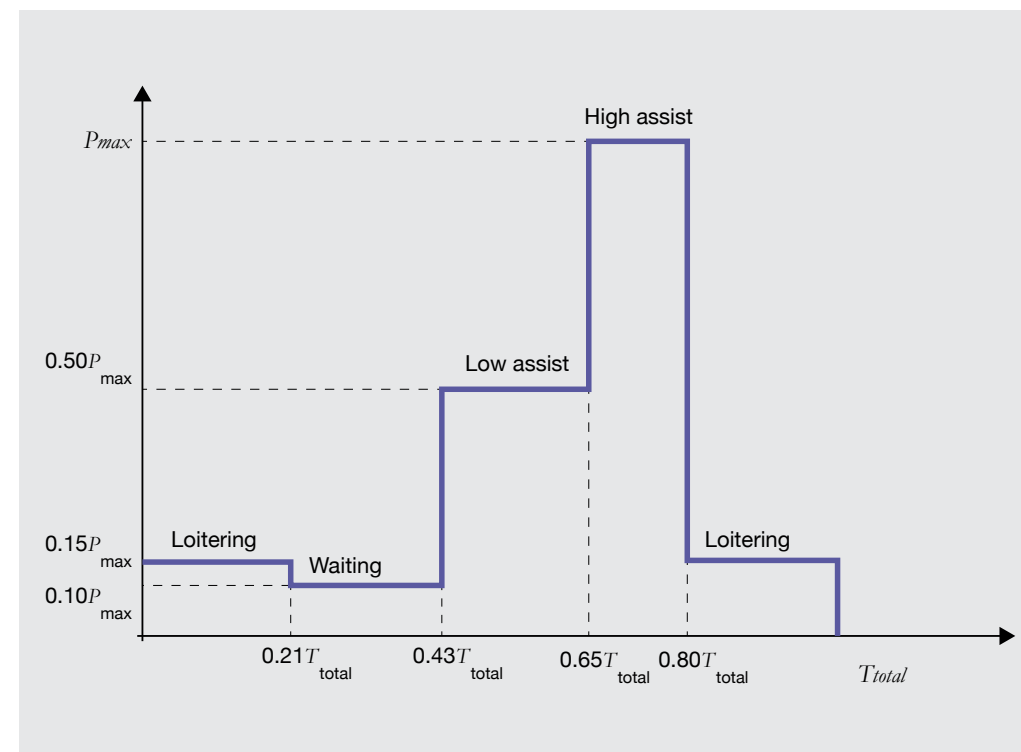
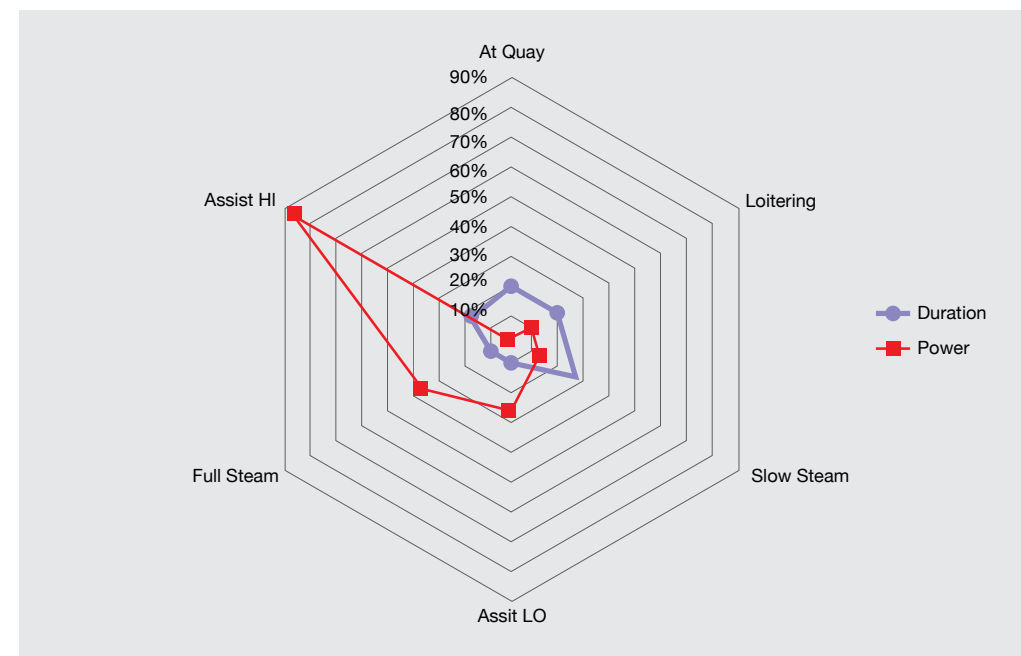



this waiting period are similar to those at the quay. The power demand during servicing is usually higher and includes assisting at medium-load (low assist) and high-load (high assist) demand. Lastly, another period of loitering/slow steaming is required for the tugboat to go back to its station.

### Optimization of a tug design equipped with Onboard DC Grid

In general, an optimization problem is formulated as:

$$\min J(x) \text{ subject to } G(x) \leq 0$$

The cost function  $J(x)$  takes into account the different trade-off costs that a tug owner may encounter during investment in and operation of the Onboard DC Grid-based tug. The constraints  $G(x) \leq 0$  represent the physical system limitations or design limitations imposed by practical considerations. The physical system limitations are inherently captured by the mathematical model of a tug equipped with Onboard DC Grid that was presented in the previous section. MATLAB software has an optimization toolbox containing standard optimization routines, including the genetic algorithm routine, which was used to evaluate the solution in this case. The advantage of using MATLAB/Simulink is that both the system constraints specified using the Simulink model, as well as additional design and practical constraints, can be programmed and considered during the evaluation of the optimized solution.

#### Problem formulation for design optimization

For selecting a given design configuration, the tug owner must consider the upfront equipment and manufacturing cost of a tug, as well as the fuel and

maintenance cost distributed over the operational life cycle. Thus, the cost function for the optimization problem was formulated to have three terms as:

$$J = w_1 \times \text{Equivalent Equipment Cost} + w_2 \times \text{Design Cost} + \text{Fuel Consumption Cost}$$

where equivalent equipment cost accounts for equipment purchase and maintenance, and the design cost accounts for cost associated with the space requirements of the installed power distribution system. These costs are a function of the various diesel engine generator and battery pack candidates considered in a tug design. Each candidate is defined by the equivalent equipment/maintenance costs, space requirements and power rating. The weights  $w_1$  and  $w_2$  allow for flexibility to put more emphasis on certain costs than others, as is often dictated by practical considerations. For example,  $w_1$  and  $w_2$  may be selected to be greater than 1 if upfront costs need to be penalized more or less than 1 should the regulations require reduced emissions, which can be translated to less fuel consumption.

Besides the system operation constraints that are inherent in the Simulink model, additional design constraints that arise from practical considerations are also modeled. For example, classification societies require that the total installed engine capacity be more than the rated power of the tug, and the DC bus voltage should be within a nominal narrow band for proper functioning of installed equipment.

#### Results of design optimization

The optimization formulation for the tug design problem presented so far was simulated to determine

6 Optimal design configuration for a tug equipped with Onboard DC grid over a five-year time horizon

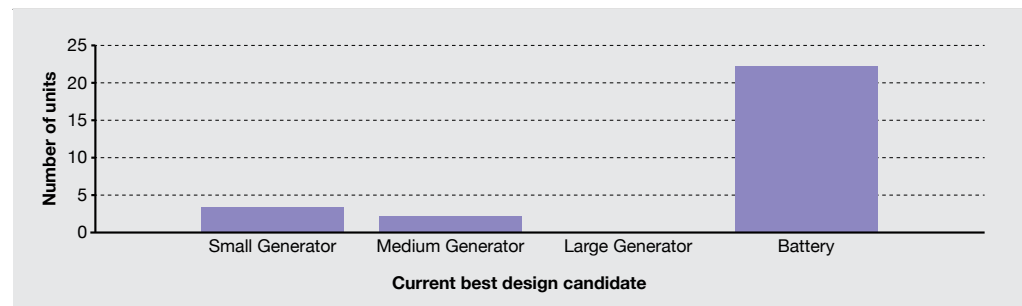

Table 1. Cost breakdown for the optimal design and corresponding efficiency

Cost component	Cost (\$)	
	Optimal Electric Tug	Mechanical Tug
Equivalent Equipment Costs	3,059,000	2,813,333
Design Costs	320,736	126,945
Fuel Consumption Costs	10,642,000	13,207,000
Efficiency	33.15 percent	31.59 percent

an optimal design for a tugboat. The fuel costs were calculated over five years assuming repeated operating cycles of 90 minutes each, with six cycles per day. Figure 6 provides the optimal solution picked up by the genetic algorithm routine, which recommended using three small engine generators of 800 kW, two medium engine generators of 1075 kW and 22 modules of batteries, each of 6.5 kWh capacity. It is noteworthy that small engine generators are preferred over larger engine generators of 2500 kW. Using small engine generators allows switching of the engines sequentially, such that for most operating conditions the running engines are operating at near optimal conditions. Further, it can be seen that the battery capacity recommended is very small, compared with the engines. This indicates that even a small battery capacity can provide significant improvement in efficiency through load smoothing of engines. However, as the battery capacity is increased further, the efficiency improvement achieved is not significantly high enough to justify the cost of additional battery investment.

Table 1 compares the costs incurred by the recommended optimal design candidate with respect to the mechanical tug configuration. It can be seen that while additional investments are required in equipment and design, costs are recovered in fuel savings through improvement in efficiency. Also, it must be noted that the fuel consumption cost and efficiency improvement is based on a simple rule-based power management system described in the previous section. However, in the next section, we describe how to intelligently switch on and off the engines and utilize the batteries. The implementation of such power management systems should provide even more fuel savings and efficiency improvements, which could make the Onboard DC Grid equipped tug an even more attractive option.

### Optimization of electric tugboat power management

#### Problem formulation for optimization of power management

In the previous section, the problem formulation presented included the cost associated with manufacturing a tug of a given configuration and its operating cost. Once a tug design is finalized, the main consideration for a tug's owner is to get the maximum mileage from the investment. This requires an intelligent use of resources on a tug equipped with Onboard DC Grid, which can result in maximum fuel savings while meeting the load demand as dictated by the tug's operation. As in the previous optimization formulation, again, there are trade-off costs involved. For example, fuel savings can be obtained by reducing the diesel engine's power output, but batteries may not have sufficient stored energy to meet the load demand. Even if batteries are used to meet the load demand, the stored energy needs to be finally recovered by either onboard generation or purchasing it from the grid. Thus, a new problem needs to be formulated to determine the optimal power management strategy that accounts for these cost trade-offs. The chosen cost function accounts for the fuel consumption, change in stored energy of the battery and the ability to track the given load profile as:

$$J = \text{Fuel consumption} + \gamma \times \text{SOC change} + \lambda \times \text{Load tracking}$$

As in the case of the previous optimization formulation, the model presented in Figure 2 can be used to describe the system operation constraints. A limitation of using the described mathematical model of electric tugboat subject to the cost function for power management is that at each time several solutions

using a different combination of power outputs from engines can exist for operating at a given efficiency. Therefore, the optimization algorithm often recommends random and unnecessary power switches among different engines at each time step. Such random and unnecessary power switches are uneconomical and detrimental to the health of the system. A typically detrimental and uneconomical solution that the optimization algorithm can recommend is when an  $i$ th engine switches from on mode to off mode, while another  $j$ th engine switches vice versa. If  $n_i(k)$  represent that an  $i$ th engine is running ( $n = 1$ ) or switched off ( $n = 0$ ) at  $k$ th time instant, then to eliminate such redundant switches, the following conditions are set on the operation mode of each combination of different engines as:

$$\left| (n_i(k) - n_i(k+1)) - (n_j(k) - n_j(k+1)) \right| \leq 1$$

for all possible time instants  $k$

Another similar issue can be related to frequent switching on and off of the engines. Once an engine is switched on, it is usually desirable to run it for at

least a certain length of time. A start-up operation of an engine usually penalizes the fuel consumption heavily and results in more pollutant emissions, compared with continuous operation of the engine. A similar constraint can be included between different time samples to avoid rapid on-off switching of an engine between consecutive time instants as follows (assuming that  $i$ th engine is running at  $k$ th time instant):

$$(n_i(k) - n_i(k-1)) + (n_i(k) - n_i(k+1)) \leq 1$$

for all possible time instants  $k$

#### Optimized results for power management: known load profile

Consider an ideal case, where the operation profile of the tug is known in advance. This is similar to the case when the tug does the same task repeatedly. In this case, while neglecting small variations that may occur due to weather and waves, both the power demand requirement and the respective duration at each power demand level can be known *a priori*. Pre-programming for power output/operation of the engines and the batteries is then sufficient to ensure

7 Load profile demand used in optimization formulation

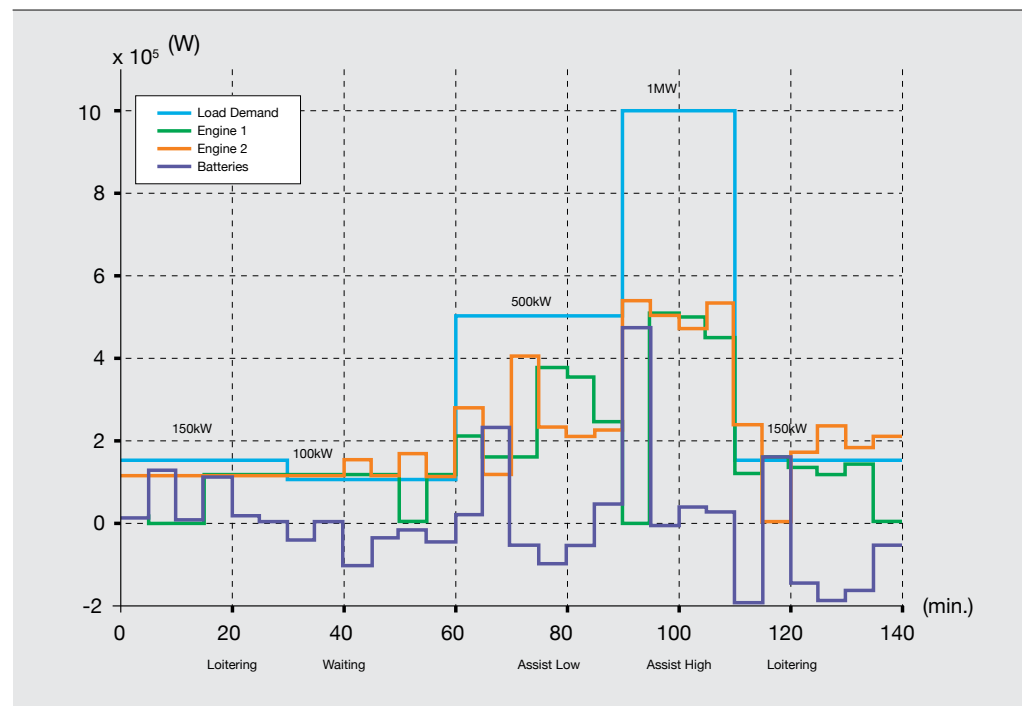

system's efficiency. Figure 7 shows the results from optimization for a similarly known load profile (which is the same as shown in Figure 5). It can be observed from Figure 7 that the engines usually operate with higher power output in response to the load demand during the assisting modes of the tugboat, and operate at a lower power output or switched off mode to reduce fuel consumption during the low load demand periods. It can further be seen that during some operating periods, for example 5 to 10 minutes, the batteries can discharge to respond to the load demand, allowing one or more engines to turn off, which reduces the engine fuel consumption. Conversely, during some operation periods, especially observed at the end of the operating cycle for shown results, the batteries may charge to exploit the surplus power generated by the engines, which reduces the wasted power.

#### Optimized results for power management: unknown load profile

Generally, the exact load demand for a tug is not exactly known. However, based on the port where a harbor tug is operated, its general operating characteristics such as the relative amount of time spent in each operation mode can be deduced. A wide variety of research in load prediction is available for marine vessels and land-based vehicles, which includes artificial neural networks, support vector machine, fuzzy network and numerical methods. While these methods are effective when a lot of data from measurement and system information is available, it is not straightforward to use information about general operating characteristics of a harbor tug to predict the load and demand and optimize using the formulation presented earlier. Therefore, a novel prediction scheme, which only requires information regarding the general characteristics of tugboat operation, is proposed in this research to forecast the load demand and then combined with the optimization formulation for power management presented earlier in this section to determine the engine and battery power outputs and the engine operation schedule.

The mechanism of prediction scheme is based on the historical load profile information and the general operational characteristics of a typical harbor tug profile shown in Figure 4, that is, the low-load demand occurs for around  $a = 65$  percent of the overall

operating cycle, the medium-load demand occurs for around  $b = 20$  percent of the operating cycle and the high-load demand takes around  $c = 15$  percent of the operating cycle. Let us say that in an operating time interval  $[0, n\Delta t]$ :  $a_n\Delta t$ ,  $b_n\Delta t$ , and  $c_n\Delta t$  were the time intervals for which the tugboat operated in low-load, medium-load and high-load demand modes respectively. Here  $n$ ,  $a_n$ ,  $b_n$  and  $c_n$  are integers such that  $a_n + b_n + c_n = n$  and the sequences  $[a_n]_n=1$ ,  $[b_n]_n=1$  and  $[c_n]_n=1$  are increasing. To predict the load demand in the interval  $[n\Delta t, 2n\Delta t]$ , the integers  $a_{2n}$ ,  $b_{2n}$  and  $c_{2n}$  are identified such that:

$$\begin{aligned} \frac{a_{2n} - a}{2n} &= \frac{2}{3} \left( \frac{a_n - a}{n} \right) \\ \frac{b_{2n} - b}{2n} &= \frac{2}{3} \left( \frac{b_n - b}{n} \right) \\ \frac{c_{2n} - c}{2n} &= \frac{2}{3} \left( \frac{c_n - c}{n} \right) \end{aligned}$$

It can be verified that this prediction scheme ensure that the time percentages for which the tugboat operates in low load, medium load and high load satisfy:

$$\begin{aligned} \lim_{n \rightarrow \infty} \frac{a_n}{n} &= 65\% \\ \lim_{n \rightarrow \infty} \frac{b_n}{n} &= 20\% \\ \lim_{n \rightarrow \infty} \frac{c_n}{n} &= 15\% \end{aligned}$$

The prediction scheme can be integrated with the power management optimization to successively find an optimal power management scheme over increasing time horizons. For the first iteration, when the load measurement is not available, the general operational characteristics can be used to determine the optimal schedule for engines and batteries. After the first iteration, the load profile during this interval is known and can be used to predict the load up to twice the length of the load measurement. Thus, the predicted load from a given time instant to the subsequent time horizon can be used for evaluating the optimal schedule for engines and batteries in the next iteration. This process can be repeated until the operation cycle terminates.

Figure 8 shows a comparison between the load prediction utilized for optimization and the assumed

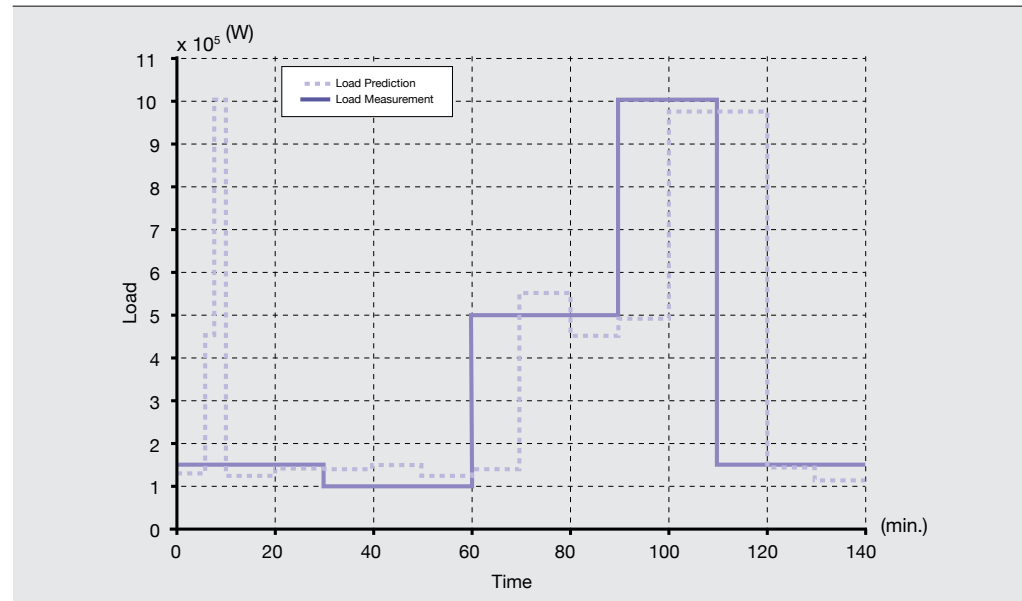

load measurement of electric tugboat during a 140-minute operation cycle. The prediction scheme anticipates that the tugboat operates in low-load, medium-load and high-load demand modes for around 61.4 percent, 22.9 percent and 15.7 percent of the working cycle respectively. At each iteration step, the load prediction in the subsequent time horizon of 10 minutes' length is combined with the optimization formulation presented earlier in this section to determine a solution regarding the engine/battery power output and the engine operation schedule in that predicted horizon. The overall schedule for engine and battery power output for the entire operation cycle is shown in Figure 9. It was found that the fuel consumption in this prediction-based solution, when compared with that in the ideal optimum solution shown in Figure 7, showed an increase of 6.07 percent. This increase in fuel consumption is marginal, when compared with the benefits obtained from the use of hybrid tug configurations, which demonstrates the effectiveness of the proposed power management scheme.

### Concluding Remarks

Research and development is needed to accelerate the acceptance of Onboard DC Grid and hybrid electric vessels by the marine industry. However, prototype

building is expensive and is not always feasible to fully investigate the full potential of the added investment in these vessels. The research summarized in this article describes the mathematical modeling with key system considerations that the researchers at Nanyang Technological University developed with design input regarding Onboard DC Grid-based tugs from ABB Singapore. The mathematical model was programmed in the Simulink environment of MATLAB and later used for optimizing the tug's design and power management strategy. The optimization of the tug's design was done to determine the ideal investment in diesel engines, including the number of engines and power rating of each engines and battery packs that would provide a return on investments over a given time horizon. The costs considered in this investigation included the equivalent equipment and maintenance costs, the costs associated with space requirements of the power distribution system and fuel costs. The optimization of the power management strategy evaluated the running schedules for engines and batteries including their power output that would results in minimum operating costs. This optimization problem can be easily solved if the load demand profile is known a priori, which can be the case if the tug repeats the same operation over and over. However, usually only the general operation

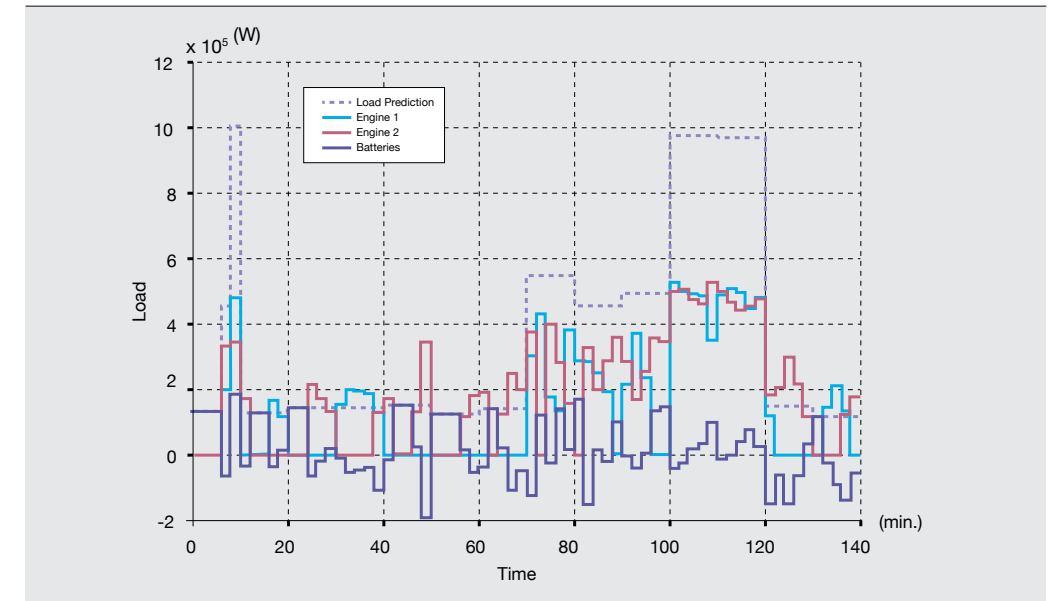

characteristics of a tug are known, which can be deduced based on the location and the expected job profile in that location. For the situation where general operating characteristics of the tug are known, a load prediction scheme is proposed, which is integrated with the optimization formulation for power management to determine running schedules of engines and batteries over subsequent time horizons. More technical details regarding the mathematical models and both optimization algorithms can be found in the list of references included at the end of this article.

### Acknowledgment

The authors are pleased to acknowledge the financial contributions of the Maritime Port Authority of Singapore to conduct this research (research grant M4060926). The authors are also grateful for several insightful discussions held with Louis Kennedy and Alf Kåre Adnanes from ABB Singapore.

### Notes

1. Gaston, J. M. (2010). Owners turn their attention to 'Greener Tugs.' Tugs, Towing, Pollution & Salvage.

### References

- Ayu, A. A., Vu, T. L., Dhupia, J. S. (2013). *Optimal Design of Hybrid Power-Plant Using Optimisation Techniques Applied to Electric Tugboat Power Distribution System*. Tugology'13.
- Vu, T. L., Dhupia, J. S., Ayu, A. A., Kennedy, L., Adnanes, A. K. (2014). *Optimal Power Management for Electric Tugboats*. IEEE Transactions on Control Systems Technology.
- Ayu, A. A., Vu, T. L., Dhupia, J. S., Kennedy, L., Adnanes, A. K. (2014). *Optimal design solution for electric tugboat under current and future market trend*. IEEE Transaction on Intelligent Transportation Systems.

### Jaspreet Singh Dhupia

Assistant Professor, School of Mechanical & Aerospace Engineering, Nanyang Technological University, Singapore  
 djaspreet@ntu.edu.sg

### Aaron Alexander Ayu

Doctoral student, School of Mechanical & Aerospace Engineering, Nanyang Technological University, Singapore  
 aayu1@e.ntu.edu.sg

### Thanh Long Vu

Postdoctoral associate, Department of Mechanical Engineering, Massachusetts Institute of Technology, USA  
 longvu@mit.edu



# Total integration reduces installation and other costs

**JOHAN PENSAR – The benefits of total integration have been lost in the complexity of the engineering it requires and, until recently, in the conservative class rules that have favored traditional technology. However, these factors need no longer be a hindrance to reaping the cost-saving and other rewards of total integration.**

Many cost and operational benefits – such as reduced footprint, better use of space, lower product costs, as well as a more efficient engineering, commissioning and operation of the ship – could be found in a more efficient integration of the systems. However, these benefits are often lost due to the complex engineering needed to integrate the different systems and components.

Complexity is due to the various communication protocols, fieldbuses, speed requirements and unconnected tools used to manage the information. Information is therefore typically mostly exchanged via hardwired signals or through slow serial lines – and often limited to the signals absolutely necessary for the operation.

Another reason for the slow introduction of totally integrated systems is conservative class rules that have favored traditional technology. With an increasing understanding of the reliability benefits, and with new technologies securing a segmented and autonomous operation, recent additions to the class rules now allow systems to reap the benefits of total integration. Some of the challenges, as well as the benefits and

opportunities of a totally integrated solution will be discussed below. In addition, some solutions from ABB that provide total integration possibilities from the intelligent device level all the way up to the operator in the control room will be presented.

## Horizontal and vertical integration

The complete power and automation solutions in a ship are depicted in Figure 1. The various systems, from propulsion and power systems up to fleet management systems, form a hierarchical structure. The main and most important parts are related to power generation, distribution and consumption (in the form of, for example, pumps, fans and propulsion motors) that all are essential systems for ship operation. Automation, found on the next level of the hierarchy, is used to manage the power systems. Automation systems with monitoring and control functionalities, as well as associated sensors, actuators and drive controls, operate the power systems in a safe and efficient way. Finally, at the highest level of the hierarchy, information, optimization and various fleet management functions can be found. These systems provide help and advise personnel on board and on shore on the best and most efficient ways to operate, service and manage the ship.

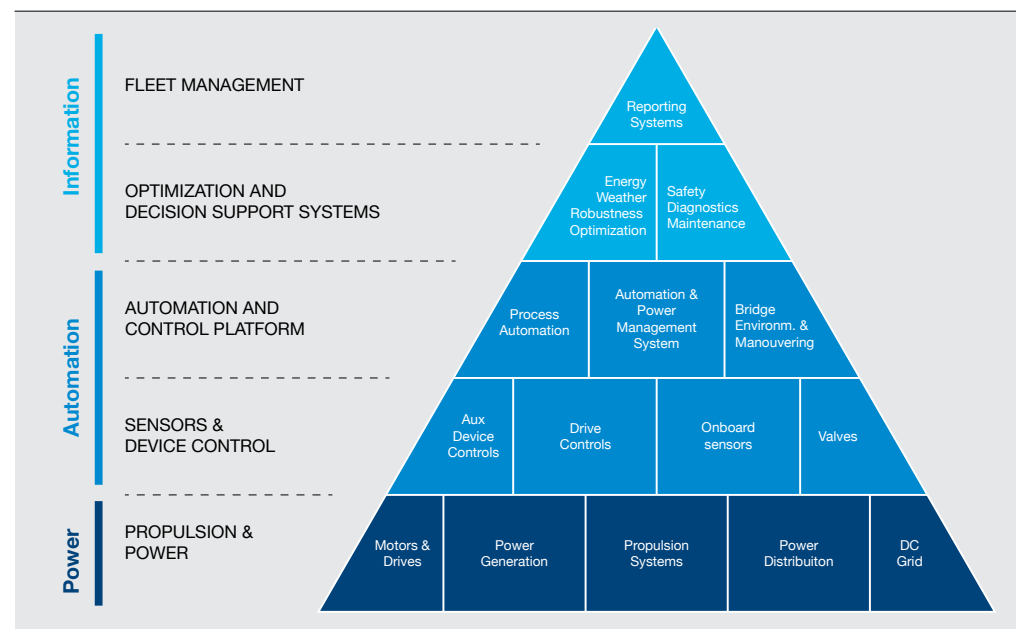

Today, what is commonly considered an integrated system on a ship is often the Integrated Automation System (IAS), which in practice is only one part of the automation layer in Figure 1. Typically, IAS solutions are based on so-called Distributed Control Systems (DCS) that are suitable for large and distributed automation applications. While originating from the process industry, a number of manufacturers have entered the marine market with DCS based IAS solutions, and today DCS technology is a mainstream solution for large ship installation.

An IAS system does, however, only address the so-called horizontal integration within the automation and control layer. That alone does not offer many cost benefits. For this, deeper and wider integration is needed. A higher and more profound degree of integration means using vertical integration between the layers – this implies the use of intelligent devices and embedded controls to achieve cost efficiency.

ABB is a global actor and forerunner in the development of vertically integrated solutions. Research and development activities in many industries with a high demand on reliability, transparency and diagnostics have built a wide portfolio of vertically integrated products and

solutions. This allows us to illustrate the possibilities with some real-world examples of total integration.

## From integrated automation to total integration

In a totally integrated solution, bus communication and embedding of intelligence are key elements in achieving higher cost efficiency. The main difference, when compared with integrated automation systems, is that in totally integrated systems, the integration of intelligence is not limited to the automation layer alone but distributed on all levels in the system hierarchy. In the ABB Totally Integrated Solution, information is also transparently transferred between all system layers, and the system interfaces at all levels are well defined to ensure compatibility, efficient engineering and optimal utilization of information.

Integration can also be done in several ways. While hypothetically total integration, as in Figure 2, could be the most cost efficient solution, several drawbacks limit its applicability. Instead, modularization and requirements on an autonomous operation favor a segmented integration model. A segmented integration model allows a high redundancy, independent and autonomous operation and secures high availability. In addition, there is more flexibility in scope from

a stand-alone product to a totally integrated system. More embedded solutions are also being used and developed, allowing for an even higher reduction in footprint and installation time. Significant cost savings can be gained from integrated system architecture, modern fieldbus technology, distributed intelligence and system-wide configuration tools.

In the fully integrated architecture, redundancy ensures the automation system has high availability, and all signals and systems are connected to the integrated system. It is:

- Cost efficient
- Transparent
- Non-autonomous
- Difficult to modularize
- Characterized by complex engineering

In a segmented integration, similar integration as in a fully integrated architecture can be achieved, but with the difference that various functionalities can be separated to different segments. It is:

- Cost efficient
- Autonomous
- Modular
- With a slightly higher hardware cost

Segmented integration can also be extended with intelligent devices – embedded controls that further reduce the complexity on the automation level. It offers:

- Same benefits as segmented automation
- Reduced footprint
- Reduced hardwired IO
- Increased factory test coverage

Figures 3 and 4, of traditional and total integration clearly show their differences. Some of the most significant technologies in Figure 4 will be explained below.

**The ABB 800xA extended automation system**

One of the cornerstones of the ABB Totally Integrated Solution is the ABB 800xA extended automation system. The 800xA system is a true and proven DCS solution that not only provides DCS control, but is highly flexible and capable of consolidating, monitoring and controlling all aspects of the Totally

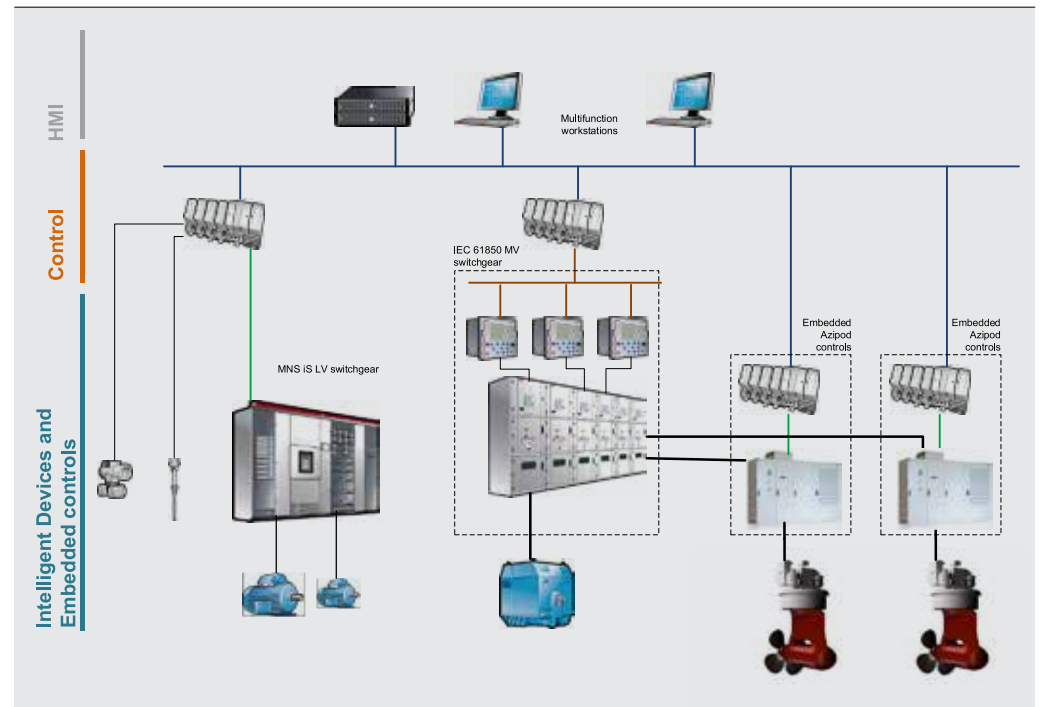
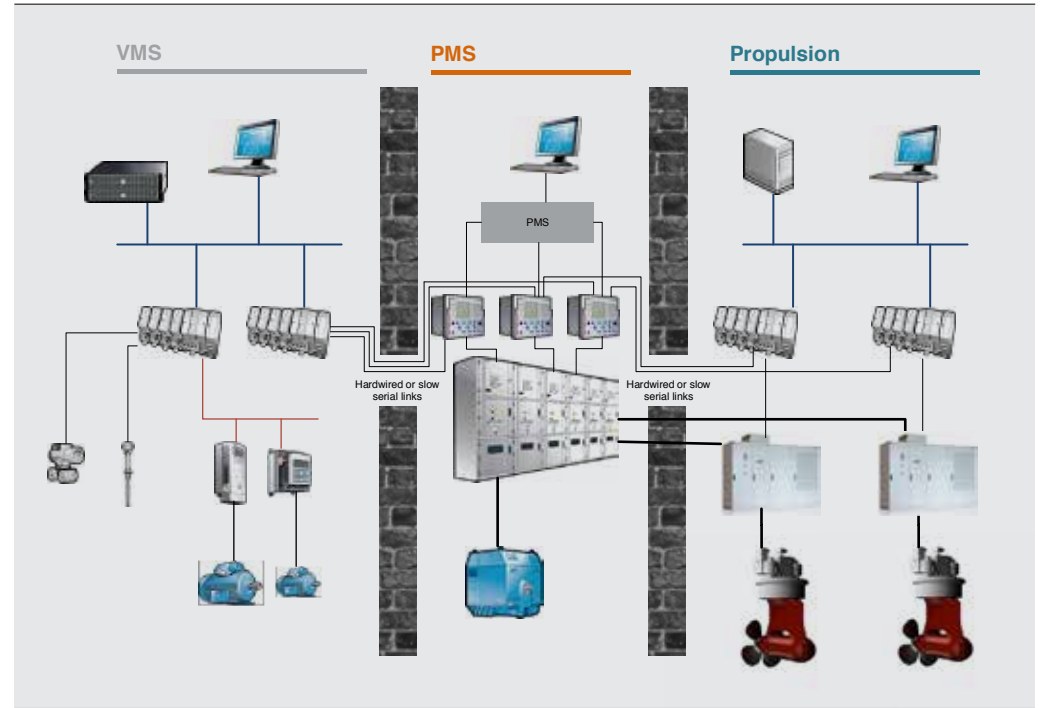
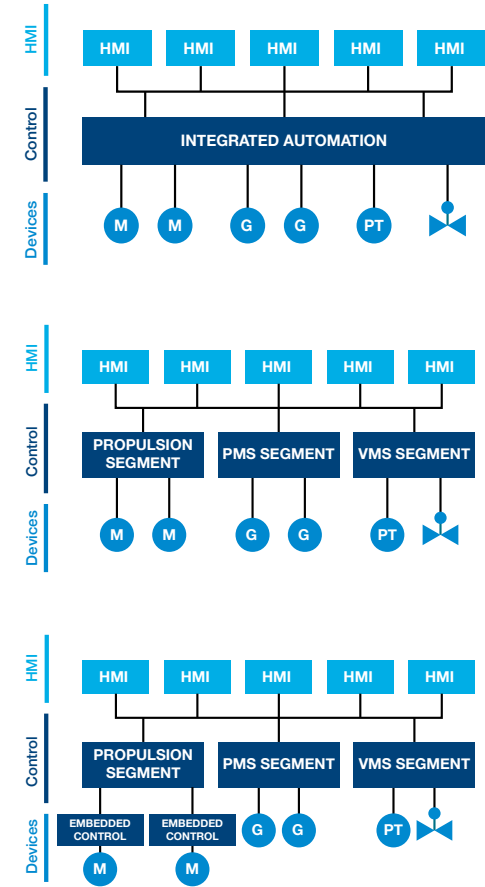

Integrated Solution. This is largely due to the high extendibility of the 800xA system, which seamlessly integrates the electrical systems with its IEC 61850 communication, drives and field devices, but also allows embedding segments of the system to, for example, propulsion controls. The 800xA system also integrates with regard to asset management, remote diagnostic and ERP systems.

A smart segmented architecture allows the control hardware to be optimally allocated in order to reduce the footprint, to optimize functionality and to meet requirements on redundancy and autonomous operation in a reliable and cost efficient way.

The 800xA system also supports transparent time stamping and time synchronization across the whole vertically integrated system. The transparent time synchronization avoids typical problems where different integrated systems may independently support accurate time stamping, but where a lack of transparent and accurate time synchronization cancels out the benefits of the time stamping.

As the space on the bridge and in the ECR is limited, other 800xA system features are also useful for multi-function displays and, for example, video integration capabilities, allowing a reduction in number of stand-alone workstations, monitors and dedicated equipment and access to total system information from any connected workstation.

The 800xA based ABB IAS libraries also provide core VMS, PMS, ESD, as well as HVAC control functionality, seamlessly integrating to power distribution, propulsion, remote control and asset management functions as needed.

Benefits of the 800xA system include:

- Platform with native support for vertical integration
- Reduced footprint for hardware and cabinets through optimal use of controllers and reduced hardwired IO
- Supports space efficient PMS integration in switchboards
- Reduced bridge and control room footprint through multi-functional workstations with access to all system information

- Easy and cost efficient commissioning with access to total system from any one workstation
- Reduced ECR footprint, with multi-functional video walls replacing expensive mosaic walls, CCTV integration, etc
- Improved functionality for, for example, black-out prevention, with full system information available

#### Relay technology with integrated switchboard communication support

Traditionally, the exchange of information within a medium voltage switchboard – more specifically the information required for protection, interlocking and operation of the breakers – has been transmitted over hardwired interconnections. The reason is simple: the protection of the system requires a very fast exchange of information in order to maintain the safety and integrity of power distribution – something that has been difficult to achieve with earlier bus technology.

Modern Ethernet technology has, however, overcome the speed limitations, and ABB has, from the beginning, taken a leading role in the development of a corresponding standard in the field of substation automation, the IEC 61850 standard. With ABB IEC 61850 conformant protection relays, bus-based interconnections within and from without the switchboard are finally possible.

Compared with non-native solutions, where delays of several seconds can be introduced, the IEC 61850-equipped protection and the native IEC 61850 implementation of the ABB 800xA DCS system allows a very fast response to events. Reaction time that results in improved blackout prevention and fast load shedding. The IEC 61850-enabled protection relays like the ABB REF620 (Figure 3) also allow low-level implementation of fast and advanced protection schemes that further increase the network stability.

Due to the reduction in footprint because of a reduced number of hardwired signals, the IEC 61850 equipped switchboard often allows the PMS system to be integrated in the switchboard without additional external cabinets. The saving in footprint therefore allows for a more compact design, and better use of space in the switchgear room.

5 REF620 protection relay



In an IEC 61850-equipped switchboard, only a small amount of alarm signals need to be hardwired (common alarm and protection relay failure alarms) between the switchboard and the automation system. For signaling between switchboard sections, all hardwired signals can be replaced by bus communication. Within a switchboard, the remaining panel-to-panel wiring consists of auxiliary power- and voltage measurement distribution as well as local backup synchronizing controls. As an illustration, in the case of a typical cruise vessel power plant with a total of 25–30 breakers, the number of external hardwired connections at the switchboard may be reduced by over 70 percent, compared with a traditional solution.

There are also significant benefits in terms of, for example, system testing. The signal interfaces between switchboards and all PMS controllers can be tested already at the engineering and factory testing phases, and will therefore be fully tested well before commissioning. There are also clear benefits if modifications are required during the commissioning, as the addition of signals or functions between parts of the system can mostly be managed without hardware modifications. In a traditional hardwired solution, new cabling or wiring, I/O -allocation, drawing modifications, etc. would be necessary.

To achieve an accurate sequence of event functionality for traditional systems, the signals need to be hardwired to IO units with accurate time stamping at source. In an IEC 61850-based solution, the timestamp for any essential signal will be recorded already at the protection relay level by default, to the highest possible precision without any additional equipment.

When connected to an IEC 61850-compatible control system, all the timestamp information will be transparently available, including for the operator, in the normal alarm lists.

The bus-based IEC 61850 communication also gives benefits in the form of higher system availability. Traditional hardwired signaling is based on the idea that alarm, control and monitoring systems are independent and use their own field instruments and signals to ensure protection integrity. In switchboard design, this means that, for instance, generator power is measured by a number of separate transducers to ensure that each receiver gets its signal from a dedicated source. While this provides mutual independence between systems, it does not increase the availability or redundancy for the individual system and gives only limited possibilities for signal quality validity checking.

A bus-based communication systems can increase availability and redundancy in several ways:

- Within one switchboard and between switchboards in a redundant ring net configuration, the optical cabling and managed switches ensure a redundant signal transmission.
- Important signals can be locally read by two independent devices, such as a protection relay or I/O-modules, to ensure that data is available to all receivers in case of a hardware failure in one I/O unit or sensor.
- Redundant gateways between control networks ensure that a single failure does not lead to loss of communication.
- Communication problems can be detected automatically, which provides loop monitoring for all signals, and signal validity and voting can be implemented for increased availability.

Benefits:

- Reduced footprint, cabling and engineering
- Increased flexibility during commissioning and throughout the life cycle
- Sequence of events and millisecond time stamping of all essential events on board
- Improved blackout prevention and load shedding
- Improved diagnostics, preventive maintenance



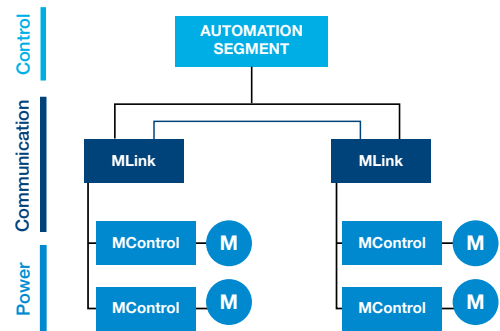

7 MNS withdrawable module with an integrated ACS 850



**ABB MNS iS bus-based low voltage switchboards and motor controllers**

As in medium voltage switchboards, where intelligent protection relays have drastically reduced the need for hardwired interconnections and simplified the integrations to automation and PMS systems, similar vertical integration solutions exist for low voltage distribution. With a fully embedded intelligence at breaker and motor controller level, and transparent communication with the higher-level automation systems, substantial benefits can be achieved.

ABB’s innovative MNS iS concept combines the long-term experience, energy efficiency, grid reliability and industrial productivity of the well-known MNS system with advanced design in hardware and software technologies. Compared with non-native bus-based integration of the LV distribution and motor control, where significant delays may be introduced, the MNS

iS solution allows for fast control, interlocking and time stamping at the device level.

The MNS iS solution also provides exceptional operational safety with physical separation of the power and control parts of the switchgear.

The MNS iS system is widely scalable and flexible, as standard power modules cover a wide range of motor starter and energy distribution applications. The associated control module is scalable from basic to complex motor starter types, protection functions and field input/output signal requirements, depending on the application. All starter level interlocking schemes between control and power modules are built in. No hardwiring or input/output assignment required. The control schematic is reduced to assigning field I/O signal contacts only.

The typical hardwired control interfaces between the IAS system and single starters are replaced by an interface module MLink, which serves as the gateway between the IAS system and individual feeders/starters via the internal bus of the MNS iS switchgear. The MLink solution not only supports IAS integration, but also time synchronization, accurate time stamping of events and alarms, integrated alarm handling as well as asset monitoring.

Benefits of the ABB MNS iS low voltage switchboards and motor controllers include:

- Reduced footprint with less physical IO
- Increased flexibility during commissioning and the life cycle
- Improved diagnostics and preventive maintenance
- Fast fault tracing
- Reduced cabling and engineering

**Drives integration**

The use of variable speed drives (VSD), which are frequency converters, instead of single-speed motors with throttle control is an increasing trend in shipboard installations, as the cost of energy has become a major factor in the economic planning of shipping companies.

The most common engineering approach is to simply place a VSD between the supplying switchboard and

electric motor. Typically, this causes disadvantages and challenges, such as:

- VSD are wall mounted as loose units or floor mounted in drive cabinets, which increases the installation footprint.
- Power cables and cabling accessories are required for interconnecting the switchgear and the VSD.
- The solution requires extensive coordination among vendors.

Instead of additional cabling and interfaces of separate VSD installations, the integration of drives into either switchgear or driven equipment brings the benefits of the smart motor control centers combined with the energy saving potential of the VSD.

ABB ACS 800/850/880 drives can be integrated into the MNS low voltage switchboard. Lower power units may be built into a withdrawable module, while higher power units are installed as fixed units into the MNS switchboard. This solution ensures the following savings at every stage of the product lifecycle:

- No more field wiring between feeder and VSD.
- No more wall mounted or standalone VSD panels, which is more flexible and optimizes of the room layout.
- One vendor handles the complete solutions, which saves hours in the design engineering and project management.

- The standardized design enables shorter engineering and delivery times.
- The integrated solution can be routinely tested at the factory prior to delivery.
- The standardized design saves on the spare parts inventory.
- Energy savings due to variable speed operation of pumps, fans, etc.

**ABB Embedded Azipod® controls**

While the Azipod propulsion system represents the ultimate solution in flexibility and energy efficiency, new control solutions aiming for a more optimized fit bring further space and cost benefits. With a design based on the 800xA platform, the new Azipod solutions are introducing products fully adapted to the segmented integration model. The new design allows for a reduction of control electronics by approximately 30 to 50 percent, and a reduction of footprint for the control cabinets of up to 70 percent. In addition, seamless integration into the 800xA IAS system, with a minimum of interfaces, allows for full monitoring and control of the propulsion system from the IAS system multifunctional displays. Full autonomous and stand-alone operation is still possible where needed.

The differences in design between the traditional and new Azipod topology are illustrated in Figure 7 and Figure 8. In the traditional topology, the Azipod controls are separate, with largely hardwired connections between each system. While providing

8 Traditional Azipod control topology

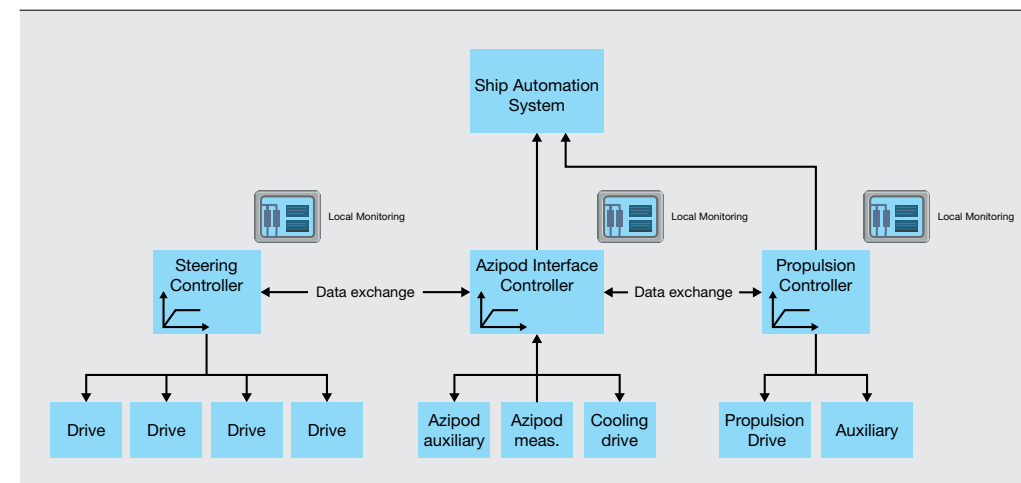

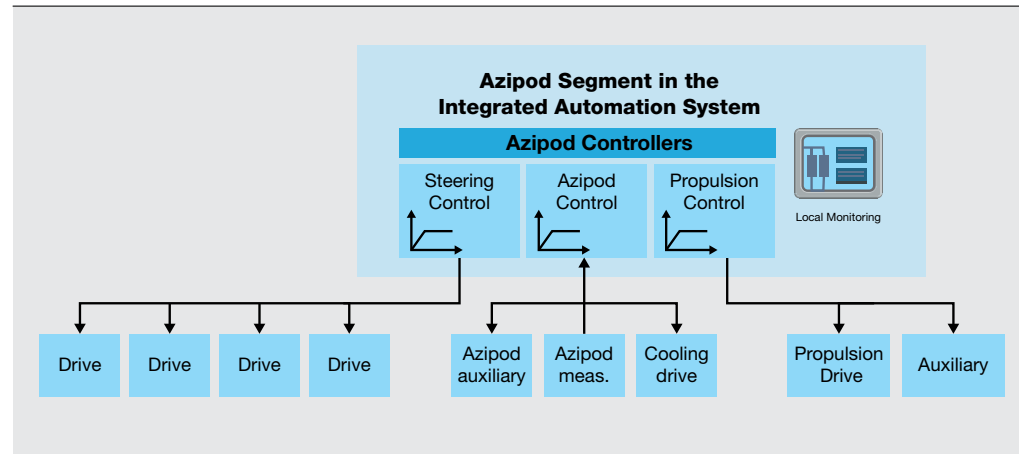

independence between the systems, the new segmented solution provides even higher reliability and full autonomy as it reduces the number of potential system damages and failures.

In the new topology, vertical integration with smart VFDs and starters is also deployed within the Azipod segment, creating a large standardized hybrid component. It seamlessly integrates into the IAS system, provides accurate time stamping and transparent diagnostics and improved network stability. With a reduced number of interconnections between the different Azipod controllers, full factory testing of the complete propulsion system is possible, reducing installation and commissioning work on site.

Benefits of the new topology include:

- Significantly reduced footprint, both for control hardware and in the control room
- Sequence of events and millisecond time stamping of all essential events on board
- Improved blackout prevention and load shedding
- Simplified commissioning and full system validation before installation
- Improved diagnostics, preventive maintenance

**ABB RCS system**

With the ABB RCS system, full integration of the bridge controls of the propulsion is also achieved. With the ABB RCS system, the RCS, the propulsion and the

power management all transparently share the full system information. One of the main benefits of the integrated RCS system, however, is that full system factory testing is possible, and that engineering of the integration is less demanding. With an RCS system taking the full propulsion system into consideration, the propulsion is also more safe and efficient.

Benefits of the system include:

- Reduced system integration
- Simplified commissioning and full system validation before installation
- Improved diagnostics, preventive maintenance

**ABB Information Solutions**

Due to the increasing costs of fuel and crew, decision support solutions are becoming more mainstream in shipbuilding. While it is possible to build an extensive decision support system based on components available on the market, the cost of integration, and the cost of potentially doubling hardware easily increases the overall price factor. With the ABB Information Solutions, the same hardware platform, sensors, workstations and information are used throughout the system, and correct information is provided in the right place at the right time. With the information available in the integrated system, no additional monitors or workstations are needed. Instead, the advice is available directly from the same multifunction displays, in affected process mimics – providing the best efficiency and



user experience. As all information in the system is also available for fleet management, transparency down to the lowest level is provided for onshore personnel.

Benefits of ABB Information Solutions include:

- Less integration costs
- Reduced hardware and footprint
- Simplified commissioning and full system validation before installation
- Improved diagnostics, preventive maintenance

**ABB Extended Operator Workplace**

While with the concept of integration is often conceived as the interconnection of various devices through hardwired or bus-based signals, an aspect of integration not often considered is the interaction between the automation system and human operator. With the focus on operator efficiency and safe operation, ABB has recently introduced the Extended Operator Workplace (EOW) concept. The ABB EOW concept involves an ergonomic and performance-enhancing environment that facilitates

safe, fast and correct operator decision making. This leads to measurable improvements in operator efficiency, safety, information exchange and operator job satisfaction.

With ready-made solutions for efficient control and bridge environments, ABB can provide cost-efficient solutions that make best of the Totally Integrated Solution. Technologies such as video integration in with separate CCTV systems, large-screen support instead of mosaic walls and integrated communication, are highly cost efficient.

Benefits of the EOW include:

- Increased safety and operator efficiency
- Cost efficient solutions for the entire control room
- Optimum integration of the ABB 800xA operator efficiency features

**The ABB Project Management and System Integration**

The individual ABB products, when deployed in a coordinated and integrated fashion, provide clear

cost benefits. However, there is another benefit to the ABB Totally Integrated Solution related to the engineering and commissioning activities required during ship design and manufacturing. Using one system supplier for the central parts of the ship systems – the power generation, distribution, propulsion, automation and control – reduces the burden on the yard in the following ways:

- Less need for system integration will not only introduce savings during the engineering phase, but also reduce risks during commissioning, because the integration is thoroughly validated by the system supplier. A single system supplier will also reduce the need for integration meetings, allowing yard engineers to focus on customer requirements and project control.
- There will be less need for FAT testing as larger units and systems can be tested and validated together, for example, validation of the main switchboard and the PMS system at the same time.
- As the total solution and all its interfaces will have been verified by the manufacturer, the testing time during commissioning will be minimized, and the number of required modifications and corrections during commissioning reduced.
- Transparent access to full ship information from the multifunctional displays will ensure faster and easier system testing.
- One ABB site manager coordinating all essential systems on site will ensure efficient commissioning and communication.
- Common competences and parts allow the flexible use of resources and spares during commissioning and operation.

Providing the customer with better and more cost efficient solutions is the ultimate goal of a totally integrated solution. However, there are challenges in achieving higher cost efficiency with a purely horizontal integration, while as the real-world examples in this article show, vertical integration provides tangible cost savings.

**Johan Pensar**  
Operations Director, Centre of Excellence, Vessel Information and Control, ABB Helsinki  
johan.pensar@fi.abb.com

#### Notes

[1] ABB review, Special report on IEC 61850

# Vertical integration offers a total propulsion solution

**ANTTI MATILAINEN, KALEVI TERVO, JUHA ORIVUORI, OLLI HUTTUNEN – Systems related to electrical propulsion are an important part of a modern vessel's vertically integrated solutions comprising electric, automation and other computer systems. Seamless data flow from propulsion to power plant, and higher-level advisory services onboard and ashore offer new possibilities for the optimal use of information.**

The current way of operating the vessel can be improved at many levels to increase the overall operational efficiency. However, to identify what needs to be changed, the current performance and its weakest points must be understood. This depends on everyone on board being familiar with the key elements affecting performance – from engine room technical staff to the crew on the bridge and operations staff at the shore office.

Figure 2 shows vertical integration in a total propulsion solution [HK1]. The various elements and features of the solution will then be discussed.

#### Azipod® Propulsion

An azimuthing electric propulsion and thruster system has a variable speed electric motor inside a submerged pod that drives the fixed pitch propeller. The pod can be rotated 360 degrees around its vertical axis.

If a vessel is equipped with two or more Azipod propulsion modules, ABB offers an Azipod dynamic optimizer (ADO) tool for the towing angle of the Azipods. This requires constant measurement of the real conditions. The system is totally automatic, constantly providing the optimum thrust for the vessel.

Azipod propulsion also enables efficient and reliable monitoring of various data. This includes the shaft-line bearings' vibration level, which is indicated to the vessel operator on the bridge. Sample-based oil analysis rounds out the condition status evaluation by providing information about the quality of oil samples taken from various pieces of equipment.

#### Propulsion control

Controller hardware and software are designed for safe operation in all conditions, as well as for high dynamic performance. Optional control parameters are flexibly programmable according to special requirements.

1 Azipod propulsor

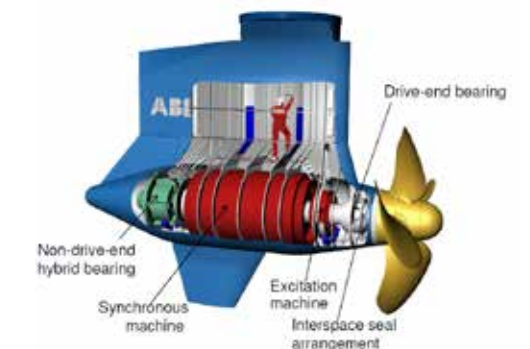



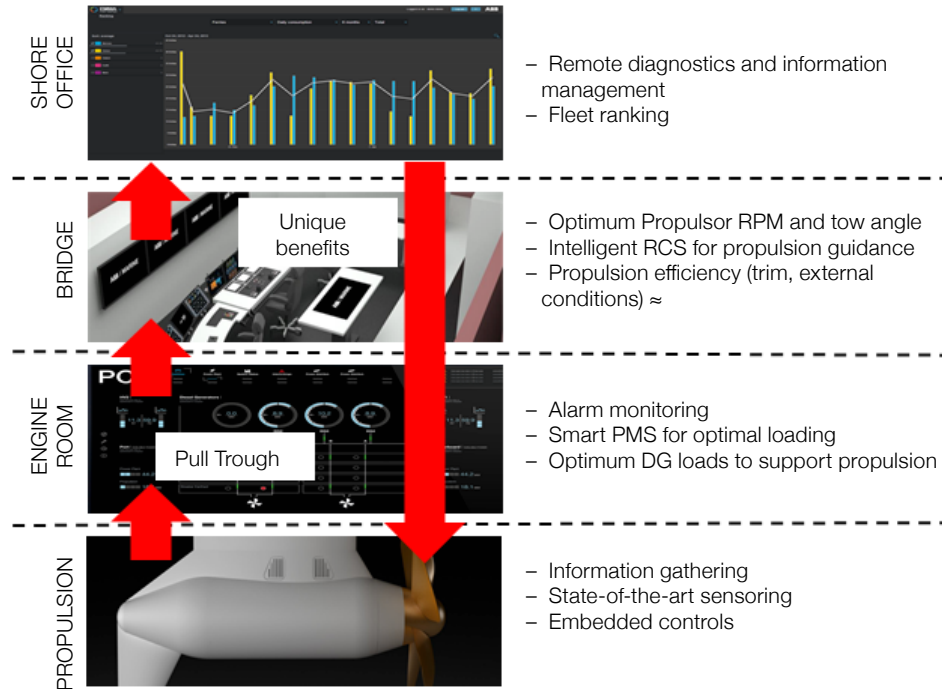

The engineer in the engine room has access to the entire automation and propulsion system. This includes:

- Engineer in engine room has access to entire automation and propulsion system
- Local and remote control
- Operational modes and control modes
- Protection functions
- Blackout protection
- Operational limitations
- Auxiliary device control
- Start interlocks

**Propulsion power breakdown**

One of the fundamental problems related to vessel operational costs is determining the work required to move a vessel from one point to another. This is a complex problem due to the many different physical phenomena acting on a vessel.

In general, the goal of a vessel is to move from point A to point B in a fixed reference frame – the Earth Centered Rotational (ECR) Cartesian coordinate system. However, the movement of the vessel takes place in two other reference frames, which change both with respect to the fixed frame and themselves. The moving frames are the media the vessel has to move through the sea and the atmosphere. The combination of these three coordinate systems form a common framework where the current power demand required to advance the vessel and its distribution can be determined at any given time.

The power required at any given time for the vessel to move can be broken down into two parts. The first component describes the power required to move through the media and the second describes the virtual power related to the changes in the sea medium frame with respect to the fixed coordinate frame. By denoting the components as powers

3 The frequency converter drive provides continuous control of three-phase AC currents from zero to maximum output frequency, corresponding to a desired shaft speed both ahead and astern. High torque is available at all speeds.

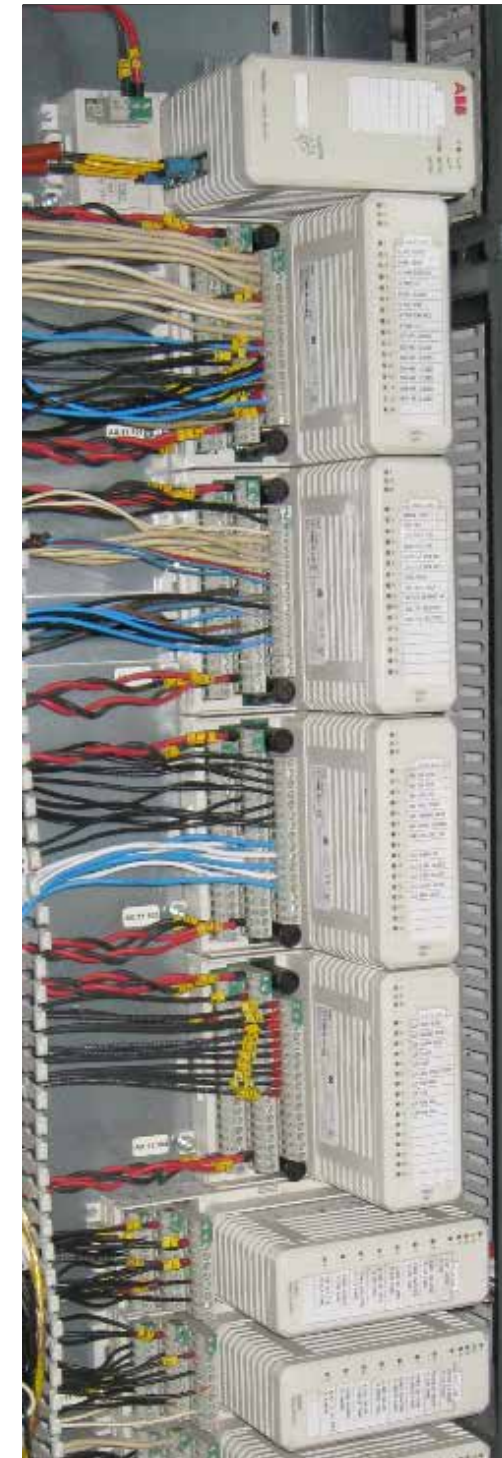

related to the speed over ground (SOG), speed through water (STW) and sea current, the following relation can be defined:

$$P_{SOG}(t) = P_{STW}(t) + P_{current}(t)$$

where  $P_{SOG}(t)$  is the power required to move the vessel with respect to the ECR frame,  $P_{STW}(t)$  is the power required to move the vessel through the water and air and  $P_{current}(t)$  is the virtual power produced or consumed by the sea current.

The power required to propel the vessel through the sea and air can be further broken down to several subcomponents that may vary depending on vessel type. This breakdown can be expressed as:

$$P_{STW}(t) = \sum_i P_i(t) + P_{wind}(t)$$

where the subscript  $i$  denotes the different power components related to the movement through water.  $P_{wind}(t)$  is the power produced or consumed by the movement of the lesser density medium (atmosphere) frame with respect to the higher density medium frame (sea) – that is, the wind power.

The power components related to the movement through water depend on the vessel type. The typical components include such phenomena as draft, squatting, rudder usage, stabilizer usage, propelling effort, the floating position of the vessel, the dominant sea state and other factors.

The different components can be described as follows:

- Draft – changes in the hydrodynamic drag due to the changes in the vessel draft.
- Squatting – additional power required in the shallow waters, where the power required to displace the water is increased.
- Rudder usage – additional drag due to the rudder angle of attack.
- Stabilizer usage – additional drag due to the stabilizer fin angles of attack.
- Propelling effort – power required to overcome both the hydrodynamic resistance of the vessel and vessel inertia.

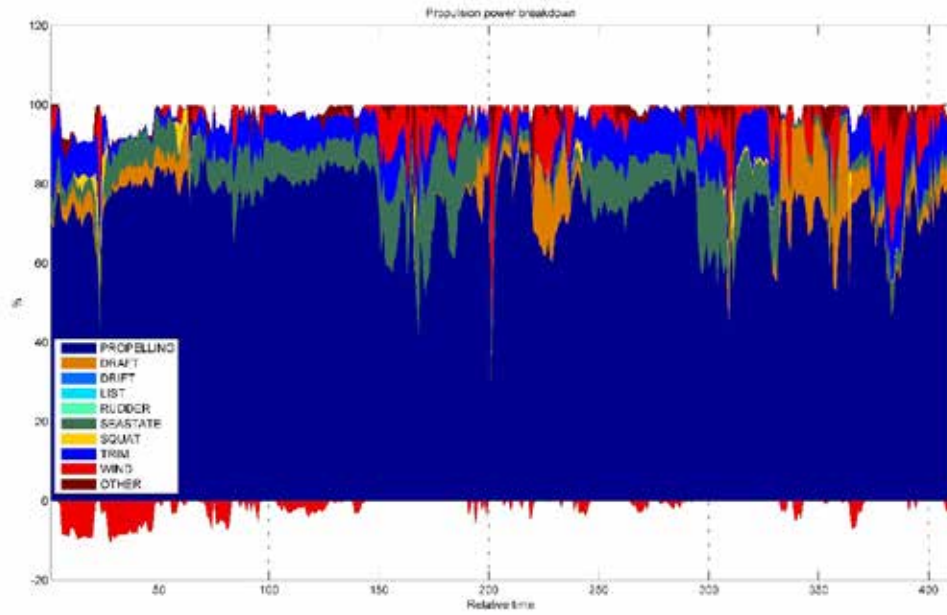

- Floating position – additional power required for moving the vessel due to suboptimal trimming and listing of the vessel, that is, to overcome the impact of the increased hull resistance and inefficient orientation of the propulsion water flow field.
- Sea state – additional power required to overcome the impact of the rough seas such as high waves slamming the vessel.
- Other factors that contribute to unidentifiable phenomena such as the hydrodynamics of the media itself.

The realized shaft-power breakdown time series collected onboard a vessel with the EMMA™ Onboard Tracker system installed is illustrated in Figure 4. According to the figure, it is apparent that significant savings could be obtained simply by changing the attitude of the vessel. In addition, the impact of the wind and sea state is clearly distinguishable. The negative wind powers indicate that the vessel hull is acting as a sail and the vessel is actually being pushed forward by the wind, thereby saving energy.

In conclusion, the power breakdown monitoring system is a good example of a system that uses the information obtained from all levels of the vessel and extracts some new physical quantities. These quantities provide additional information about phenomena that are not directly measurable, yet have a significant impact on the vessel's performance and its energy efficiency.

#### Power management system (PMS)

The ABB PMS is based on the 800xA Industrial Extended Automation System. The main task of the PMS system is to ensure a balance between power consumption and power production, thus keeping the electrical network as stable as possible. In practice this is done by controlling the electrical power

Typical actions that can be taken by the crew include trimming the vessel for a more optimal attitude and changing heading to minimize the impact of the wind and sea state losses, assuming that the deviations from the original route are permitted. The vessel operator can take several different actions based on the time series data. The route plans and schedules may be altered to avoid circumstances where the vessel is constantly going against currents, tides and prevailing winds. The vessel loading can be re-planned such that it is in accordance with the optimal draft for the intended operation profile. In addition, the power distribution time series provides a transparent view for monitoring the overall performance of the vessel.

production resources as well as controlling the usage of large consumers.

There are many ways to produce electrical power on ships. In diesel-electric vessels, the most common means nowadays is to have, for example, four diesel generators, two of which can be of different sizes. In the cruise and ferry segment, the most complex power plants are in hybrid vessels that have triple-fuel main engines with generators and steam turbine waste heat recovery systems (WHRS) as well as energy storage systems. Energy storage systems make the operation of the power plant significantly more challenging, because energy storage introduces new kinds of dynamics in the power plant. Significant fuel savings can be achieved by smart control of the power plant with a WHRS and energy storage.

The ABB PMS integrated with the EMMA™ Advanced Power Plant Optimizer is designed to optimize operation of the power plant by taking into account the current and future power demand and the operation mode. Integration with the ABB Propulsion Control System (PCS) supports optimal power plant operation even further by providing information about the expected rapid load variations in the propulsion system based on the movements of the control levers.

The levels of vertical integration during optimal operation of the ship power plant are described in Figure 6. At the highest level, the information about future operating conditions such as weather, sea state, ambient conditions, etc. is obtained from forecast databases. These are used in route planning and ship speed optimization for just-in-time arrival.

The EMMA™ Onboard Tracker uses state-of-the-art databased modeling methodologies to create nonlinear regression models for all types of performance and input variables. By using the EMMA™ model learning engine, the electrical power demand with respect to the operating conditions can be easily calculated and predicted. Consider operating conditions such as ambient temperature, seawater temperature, ambient relative humidity, amount of people onboard, local time of day, amount of cargo/containers, etc. at time  $t$  to be denoted by  $\theta_{AUX}(t)$  and the auxiliary electrical power demand at  $t$  by  $P_{AUX}(t)$

5 Real-time view of the power breakdown seen by the onboard crew. This enables the crew to detect abnormalities and take immediate and timely action.



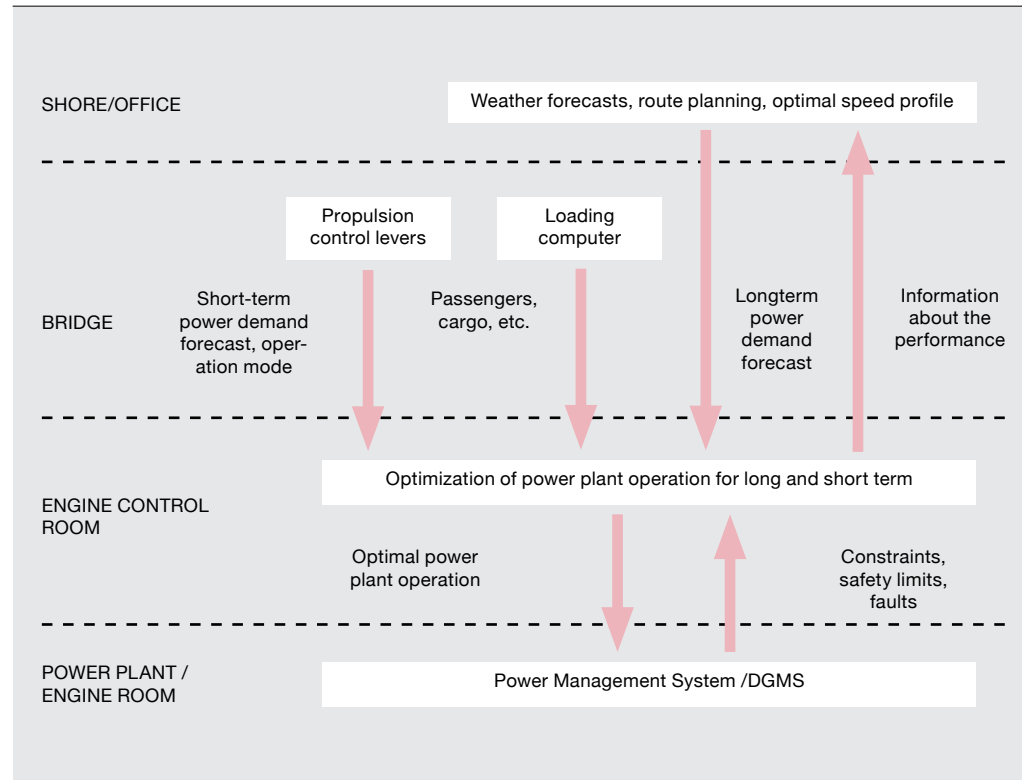

(kW). Based on data collected on board the ship during normal operation, the EMMA™ modeling engine finds a nonlinear model

$$P_{AUX}(t) = f_{AUX}(\theta_{AUX}(t))$$

that predicts the auxiliary electrical power demand as accurately as possible, based on the input data. The model learning is automatic and requires no action from the end user of the system. The modeling algorithm can automatically determine the relevance of each input signal in predicting the output value, and if some input signal has no effect on the input signal, the algorithm removes it from the model. Once the model has been trained the required auxiliary electrical power can be effectively forecast based on the weather forecasts and route information.

As with the auxiliary power demand, the required electrical or mechanical power for propulsion can

automatically be forecast using EMMA™ tools as previously described. The total electrical power demand at  $t$  is then calculated using

$$P_{TOTAL}(t) = P_{STW}(t) + P_{AUX}(t)$$

Optimal power plant usage required predictive planning of the use of the power plant resources over the short and long term. In the short term, the rapid propulsion power variations should particularly be taken into account in the optimization. Depending on the operation mode, the required spinning reserve (the maximum available power with the currently running engines/resources) varies. During maneuvering, the spinning reserve should be larger than during the sea passage.

The vertical integration in the PCS, PMS and EMMA™ power plant optimization module enables the optimization of the power plant operation so that the

operation modes and short-term power demands (1–60s) can be fulfilled. Moreover, by planning the use of the power plant resources further ahead in the future (3–24h), the unnecessary starting and stopping of engines is avoided and optimal use of energy storages and WHRS systems are guaranteed.

The integration of the ABB PMS, Diesel Generator Maintenance System (DGMS) and EMMA™ power plant optimization enables the inclusion of information about safety constraints and faults that resources that are not functioning properly are not taken into account in the optimization.

Depending on the customer's needs, EMMA™ power plant optimization can be used in real time to find the optimal load balance based on the current power demand or to optimize the use of resources within a longer time horizon. Already momentary load balance optimization enables yearly savings of about 1.5 percent in fuel consumption for a typical operation profile of a large cruise ship. By taking into account the long-term forecasts, especially in complex power plants with WHRS and energy storage, the savings potential is significantly larger.

Vertical integration in the ABB PMS and EMMA™ enables automatic use of the power plant optimization result in the PMS so that starting and stopping and the load balance between resources is performed automatically. The PMS takes care of the necessary safety limits and can reject the optimization result if it does not conform to the safety criteria.

The ABB power plant optimizer uses specific fuel oil consumption (SFOC) or other characteristic curves adjusted with statistical data from real life measurements. EMMA™ Onboard Tracker calculates the real-time SFOC value based on the measured volume/mass flow of the net fuel flow consumer by each diesel generator. EMMA™ is able to calculate the fuel mass flow based on the volume flow, temperature and fuel type by using the ASTM D 1250-04 standard methods. In addition, the electrical power produced by each generator is measured. With EMMA™, the variation due to external conditions in the measured SFOC values is compensated for by using the ISO 3046-1:2002(E) standard methods. The SFOC/characteristic curves of each resource are combined

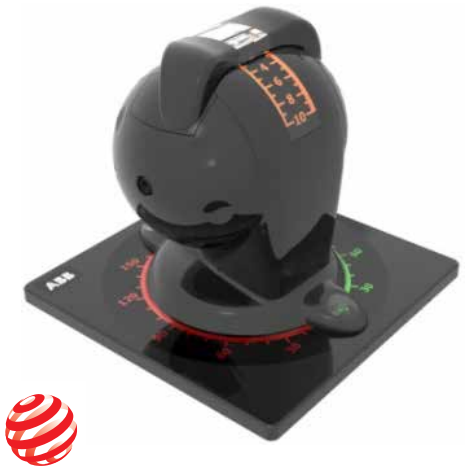

reddot design award



into a networked flow optimization problem, which is solved by ABB energy management technology designed for controlling smart grids.

ABB power plant optimization allows the user to determine and change the required spinning reserve as well as the operation limits for each power producer. Moreover, the user can exclude some resources from the optimization model in real time.

The system is also able to take into account the maintenance cycles of the power producers. Depending on the customer requirements, the optimization can be done based only on the current information or, additionally, by taking into account the future power demand, which allows the system to use the MPC (Model Predictive Control) philosophy.

### Intelligent maneuvering on the bridge

Think about a system failure within a complex automation system when operating tight routes in, for example the Archipelago Sea off Finland. Troubleshooting to solve such a situation requires only necessary information in the right place or guidance for optimal decision making in minimized time. Unnecessary system alarms can violate safe operation.

The recognition of a wide range of use situations is crucial in the development of automation systems. User-centered requirements with easy and simplified user interfaces enable the right architecture for integrated automation systems to serve the operator.

ABB Marine is cooperating with customers and end users in their research and development processes. Means and methodologies of industrial design such as concept workshops, visual communication and physical demonstration prototypes at an early phase in the process enable customer to experience the product functionalities and features. In addition, this helps to anticipate forthcoming problems and bottlenecks within the systems, which in turn allows inexpensive changes and more customer orientation in the project.

Bridge personnel can control propulsion via a remote control system. Smart remote control systems also warn about the wrong use of propulsors resulting in excess vibration and associated maintenance costs.

9 Benchmarking data visible to onboard users



### Shore asset and performance monitoring

All the data collected and calculated on board is automatically transferred to an online performance data analysis tool. EMMA™ Fleet Control is built with a high cyber security Azure Cloud service by Microsoft. This enables secure data access at any locations for the shipowner. EMMA™'s centralized database is used to form baseline and ranking of the fleet performance. This benchmarking data is replicated back to the vessels so that fleet-wide performance is visible to onboard users without a broadband connection.

Typically, the captain selects a speed somewhat above the required average speed to ensure that the ship will arrive on time. The speed/power curve of the ship is exponential and it is very expensive to exceed the required speed. By smart speed selection, the fuel saving can be significant.

ABB speed optimization calculates the optimal RPM in the cloud service and advises the officers on board on the optimum speed or RPM to reach the ETA with desired buffer time and taking the weather into account.

The speed is set on board as speed through water by adjusting the engine power or engine RPM. The actual speed of the ship is a combination of this and environmental conditions (weather, current, water depth and wave / swell height / direction / period).

10 RDS4Marine is a diagnostic tool providing troubleshooting and condition monitoring solutions for electrical and mechanical systems installed on board with remote assistance from the Global 24/7 Technical Support Center.

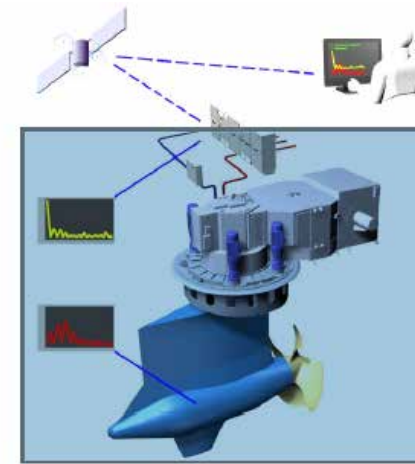

### Remote Diagnostics

Remote diagnostics give instant access to data, which helps in the planning of preventative maintenance. A service engineer will carry out planned maintenance operations based on monitoring data collected. Preventive maintenance saves service costs as service can be planned to suit the vessel's docking schedule in the best possible way.

### Power of integration unleashed

As described, through fully integrated propulsion, ABB's complete solution unleashes the real power of integration. When the ship is equipped with ABB Azipod, automation system, power management and decision support tools, the information flow is not only enabled but significantly simplified. The more the system knows, the more it is able to efficiently advise on operations and save money.

#### Antti Matilainen

Product Development Manager  
ABB Marine and Cranes, Finland  
antti.matilainen@fi.abb.com

#### Kalevi Tervo

Lead Development Engineer  
ABB Marine and Cranes, Finland  
kalevi.tervo@fi.abb.com

#### Juha Orivuori

Lead Development Engineer  
ABB Marine and Cranes, Finland  
juha.orivuori@fi.abb.com

#### Olli Huttunen

Research and Development Manager  
ABB Marine and Cranes, Finland  
olli.huttunen@fi.abb.com

# Automated container terminals are taking off

**BJÖRN HENRIKSSON – As container terminals aim for more efficient operation and higher productivity, automation is making major strides all over the world. More and more container terminals are adopting automated solutions to meet the challenge of larger ships, taller cranes and bigger call sizes.**

As in other industries, handling automation plays a key role in achieving such development in container handling. Automated systems enable remote operations, i.e., remote control of the ship-to-shore (STS) and stacking cranes as well as remote monitoring of automatic gates, where human intervention is the exception. The efficiency of operations can be further increased through the horizontal integration of these systems and equipment.

The container terminal arena is changing rapidly. More 16,000-19,000 twenty-foot unit (TEU) ships are introduced in the Asia-Europe trade every month. Within the next two years, the average ship size in this trade will reach 14,000 TEU. In addition, the cascading of

ships together with a lot of new 9,000 TEU ships will result in a doubling of the average ship size used in all other major trades within a few years. Even if the trade volumes are expected to slowly increase, the number of loops and port calls will decrease due to the increased vessel size. There were 35 vessels coming from Asia to Northern Europe in 2007 every week – this number is now down to 22 and is anticipated to continue to decrease.

Now the challenge for container terminals is to handle fewer but very large calls. Handling 20,000 TEU calls in 48 hours realistically requires about 500 TEU/hour capacity, and shipping lines will not accept lower service levels or longer times at berths. The good news is that container terminals can meet the

challenge by deploying advanced equipment and systems already available today.

## Right design criteria crucial

An automated terminal differs significantly from a manually operated one and requires an evaluation of areas such as:

- Maintenance and service
- Staff and competence
- IT infrastructure
- Risk assessment and safety
- Environmental impact
- Land utilization

Having the right design criteria and taking the correct decisions early in the project is crucial in order to meet the expected cost and performance targets. Thus, designing a greenfield container terminal is no longer just a matter of acquiring the right port equipment and integrating the equipment with an “off-the-shelf” terminal operating system (TOS). It is more a matter of designing and implementing an IT project with completely different capital expenditure (capex) and operating expenditure (opex), compared with designing a manually operated terminal.

One of the pioneers of automated container terminals was the HHLA Container Terminal Altenwerder (CTA) in Hamburg. CTA also automated horizontal transportation. After CTA's foray into automation, it took some years before the next automated terminal began operation. By 2008, automated cranes had been installed at less than a handful of terminals. So, even though automated container terminals have been around for about two decades, the trend towards automation has only recently taken off. This also means that the competence and understanding of how to build a modern automated terminal is not widespread and there are associated pitfalls.

ABB has a long history of working with automated systems for cranes and terminals. The company has introduced more and more automation functions over the years, which have allowed cranes to be partly or fully automated. Intelligent automation now enables cranes to automatically adapt to changing circumstances, optimizing performance and output.

Considering the challenge of larger ships, taller cranes and bigger call sizes that the container terminals are facing, four success factors of an automated terminal can be identified:

- Efficient STS cranes
- Intelligent automatic stacking cranes (ASC)
- Integration of terminal equipment from ship to gate
- Remote operations from a control room

ABB has, over several years, worked with each of these success factors to develop solutions that meet specific customer requirements, for example, regarding land utilization, safety and environmental aspects.

## Efficient ship-to-shore cranes

The STS cranes set the pace for the whole terminal. This means that the productivity of the fleet of STS cranes is extremely important for the commercial success of a container terminal. STS crane automation and the remote control of STS cranes are currently major trends that are profoundly reshaping crane operations. The main driver behind these trends is the need for cranes that have a lifting height of more than 50 meters. The need for such lifting heights is due to the larger ships such as the 18,000 TEU Triple-E class ships being put into service. With ships of this size, the travel distance of the trolley also increases and this requires the cranes to be run faster to maintain the productivity level. Moving human operators from the crane cabin and having them operate cranes by remote control and automation allows the full capacity of the cranes to be continuously utilized. It also opens up the possibility for the use of cranes with even higher speeds and accelerations yet to be built.

Automation for STS cranes has the following features:

- Continuous control of the load sway and skew
- Ship profiling and optimum path control
- Optical character recognition (OCR) identification of containers and vehicles enabling automatic handoff
- Measurement of vehicle position and guidance of vehicles
- Automatic container landing on platforms, ground and vehicles

1 Gate automation



2 Ship-to-shore cranes



3 Remote control station



– Single interfacing with TOS for work orders, bay layouts, container and vehicle information

Today, these functions are available for all types of STS cranes, including double trolley and/or double hoist/tandem spreader cranes. There is a clear market trend towards cranes that can handle multiple containers. For instance, between 2013 and 2015, ABB has and will deliver automation systems, including automatic landing on the quayside, for 33 cranes with double trolley and 46 cranes with double hoist or tandem operation. To date, the largest cranes have double trolley and double hoist and a lifting capacity of 130 tons under the spreader. Automation makes these complex giant machines manageable for operators and terminal logistics systems, ensuring uninterrupted production with high productivity.

Production records verify that automation improves productivity and is also “machine-friendly” since it runs the operation more smoothly than a human operator and leads to less damage to the equipment. This also reduces maintenance costs for, for instance, spreaders. Simulations verify that an inexperienced operator using automation is more productive than an experienced operator working manually.

### Intelligent automatic stacking cranes

When productivity speeds up at the quay, a fleet of coordinated ASCs becomes a necessity because it is crucial to have a high container through-put to and from the vessels. The yard must be able to fully support the quay operation and deliver good service to landside transportation. During the last decade, many terminals have implemented highly automated stacking cranes. In fact, the number of ASCs delivered and equipped with ABB’s automation system will exceed 500 this year.

Also, stacking cranes are continuously becoming larger and more advanced. Today, end-loading cranes are able to stack five to six tiers high and 10 wide, while the cantilever cranes typically stack six high and 10 to 14 wide.

The handover to all types of vehicles can be automated when proper safety arrangements are implemented. To save time, the cranes operate using an optimum path overlapping horizontal and vertical

motion, and multiple cranes in a block are coordinated to avoid waiting times.

Stacking cranes equipped with intelligent automation are able to respond to varying seaside and landside volumes and ensure timely delivery of containers for quay and rail terminal processes. The scheduling function allows the cranes to optimize the use of the cranes within the block based on all known work orders and time constraints. This improves productivity and reduces empty travel and, consequently, energy consumption.

### Integration of terminal equipment from ship to gate

The large cargo quantities to be handled in a short period of time are a challenge for the whole chain from ship to gate. Advanced on-dock rail and intermodal facilities can be used to strengthen the chain. Intermodal cranes can be automated to the same level as stacking and STS cranes. Using automated cranes and automated guided vehicles (AGVs), it is possible to move a container from the ship via the stack to a rail wagon without using any manned machine in the process.

In a fully automated terminal, accurate information about container identity and location is of the utmost importance. It is important to eliminate inefficient and risky processes throughout the chain; for example, manual handling of truck, container and driver information at the gate. Also, for STS cranes, manual handling of container and vehicle identification creates unsafe and inefficient handoff processes.

By automating these transfer points with gate, rail and crane OCR solutions, the time spent on handling the containers is significantly reduced, greater inventory transaction accuracy is achieved, truck turn times within the terminal are reduced, and the safety is increased. At the Group Maritim TCB terminal in Buenaventura Columbia (TCBuen), where such a solution was delivered by APS Technology Group, a member of the ABB group, STS crane productivity also increased by three moves per hour thanks to faster handoff of the containers.

Recently, Yilport also selected gate automation and operating solutions delivered by APS Technology

Group for its four multipurpose ports in Turkey. Yilport will also implement APS Technology Group automated container identification and handoff solutions at the quay using crane OCR at its facilities in Gebze, as well as at its new terminal, Gemport, under construction in Gemlik. With these solutions, Yilport will be the first terminal operator in Europe and the Middle East to manage exceptions across all gates and cranes at multiple terminals from one central and remote location in real time. The solution also provides full support for Yilport’s enterprise reporting.

### Remote operations from a control room

Today, remote operation and exception handling are an integral part of automation that enables people to be separated from machines and moved from a dangerous and harsh working environment to the safety and comfort of a control room. The remote operation also creates an attractive working environment for the next generation of port staff and reduces absence.

Due to the increasing height and capacity of the cranes, the working environment of STS crane operators has been deteriorating over time in spite of investments made in better cabins, etc. This undesirable development needs to be turned around if operators are to work until the steadily increasing retirement age for this occupation without developing health problems caused by poor working conditions.

ABB has developed new ergonomically designed remote control stations for operators monitoring and supervising automatic cranes and for handling exceptions. The layout of the joysticks and controls in the remote control station is the result of careful ergonomic analysis of operators’ workflow and cooperation with crane operators. The controls are positioned in a way that supports the operator’s natural workflow.

In addition to a clearly improved working environment, remote operation increases productivity, improves safety and reduces energy consumption in the following ways:

- Supports seamless operation without any loss of time at shift changes/breaks, etc.
- Eliminates time and cost needed for transportation of staff to cranes.



- All cranes are immediately available; for example, moving four containers from a feeder vessel takes a few minutes instead of up to an hour when you do not have to move the operator to/from/between crane(s).
- Onboard cameras provide better views than is possible from the cabin in situations like landing containers on a ship/vehicle or handling hatch covers close to ground.
- No need to change into special clothes and gear.

There is one additional benefit with operations from a control room that deserves to be highlighted. Remote operation means that the team comes together in one location. The terminals are run by a team of motion, logistics and maintenance specialists who handle the planning and manage exceptions together. This results in a new level of collaboration and team spirit because everyone easily interacts and shares the same view.

Systems like the ABB Terminal View provide an overview of the entire terminal. This enables a multidisciplinary group to identify bottlenecks, which optimizes processes and sets priorities to increase productivity.

The recent orders for cranes and other equipment show that the industry is moving towards more advanced equipment, integrated systems and automation, involving the whole chain from ship to gate. Automated horizontal transport is being delivered to several terminals.

ASCs are the forerunners of automation and are now moving the automation frontier to new regions like Central America with projects in Mexico and Panama. For example, the Manzanillo Terminal (MIT) in Panama is strengthening its yard crane fleet with six automated cantilever stacking cranes, which will operate alongside the existing rubber tyred gantry cranes (RTGs). This is a good example of how automation can also be deployed in an existing terminal to significantly increase the terminal's container handling capacity.

The changes that we now see in the industry are based on urgent needs and the availability of suitable technologies. This means that we will see a fast transformation of our industry within the next few years.

**Björn Henriksson**

Technology manager, Center of Excellence, ABB Cranes & Harbor Sweden  
bjorn.henriksson@se.abb.com

# Motion analyses offer superb support on board

**LEON ADEGEEST – Because of the complexity and value of marine heavy transports and operations at sea, the performance of dedicated motion analyses is not only required but also beneficial. The results of such analyses are primarily required during the transport preparation phase, from quotation to the design and engineering of the stowage plan, cribbing and sea fastenings. However, the same results and models can be of benefit during the transport phase and operation in the field as well.**

Commonly used guidelines to carry out motion analyses as part of transport engineering are those by Noble Denton<sup>[1]</sup> or DNV GL<sup>[2]</sup>. In addition, the vessel and cargo will have their own specific limitations and restrictions on maximum allowable accelerations and motions.

Traditionally, marine transports are engineered to satisfy design criteria in terms of allowable wave heights. The “allowable wave height” can be calculated as the “allowable response level” divided by the “response level per unit wave height.” It follows that different responses may result in different allowable wave heights, depending on the allowable response level.

It is obvious that the allowable wave height also depends on the other wave parameters, like the wave period, spectrum shape and spreading.

Operational parameters, like the vessel heading and speed, may have a major effect on the response level in a certain sea state, and thus on the allowable wave height. The same applies for the vessel's

voyage plan. This is why weather routing is commonly applied. In general favorable wave headings for roll are unfavorable headings for pitch and the related accelerations. Detailed knowledge about the vessel's seakeeping behavior makes it possible to do more advanced weather routing, namely by evaluating and optimizing for ship responses in the forecasted weather. Weather can refer to precipitation, fog, etc., but for the purposes of this paper it refers to waves in particular. Wind and current are also considered.

In fact, we are not referring to one allowable wave height, but to many allowable response levels. Each allowable response level implies a related allowable wave height, which again may depend on wave heading, etc. This results in a “minimum allowable wave height.” A balanced design of sea fastenings should therefore be based on a calculation of the expected levels of the relevant responses in the most likely wave environments.

The first part of this paper describes the calculation of typical design values such as the linear and angular motions and accelerations, which are used as input for the cribbing and sea fastening design. It will also

1 Analysis sequence for the calculation of design values

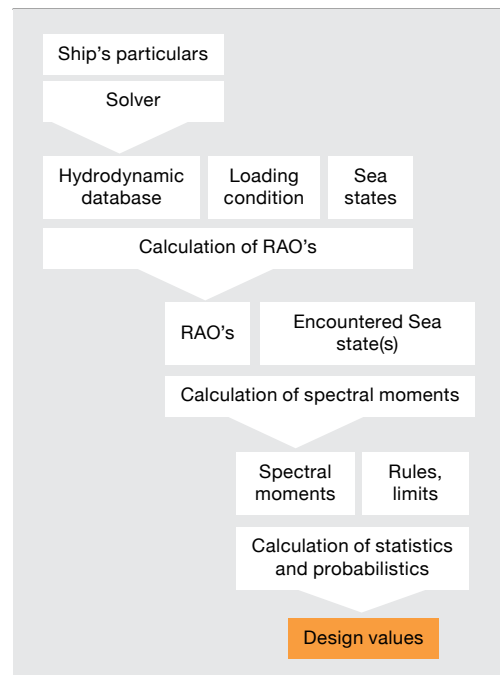

be demonstrated how leg bending moments can be calculated in the same way. A general procedure for the calculation of the design values for motions, accelerations or leg bending moments includes:

- A vessel stability analysis to derive the proper mass and stability parameters
- Assessment of the environmental conditions which may be encountered
- A motion response analysis resulting in design motions, accelerations or other responses in critical locations on the vessel and cargo

The analysis sequence, as applied for the purposes of this paper, is shown in Figure 1. The obtained design values may serve as the criteria that should not be exceeded during the transport or operation. The second part of this paper describes how to give onboard operational support using the same methods and results as used in the design value calculation procedure.

### Transfer functions

Motion transfer functions (often called Response Amplitude Operators or RAOs) in six degrees of

freedom are the basis for the calculation of transport design values. 3D diffraction theory with forward speed effects has been used for the following reasons:

- Heavy transport vessels and barges are often characterized by a large beam-to-draft ratio. For those hull shapes, 3D diffraction theory performs better than 2D strip theory
- A proper accounting for forward speed effects may be very important in stern quartering waves
- 3D codes are more accurate for calculating longitudinal accelerations

To use 3D diffraction codes in an accurate, robust and efficient way, and suitable for design optimization and onboard decision support, a special procedure has been developed [4, 5], consisting of the following steps.

### The hydrodynamic database

A hydrodynamic analysis in OCTOPUS starts with the calculation of a hydrodynamic database. This database does not depend on the loading condition. The procedure is as follows.

At first, a detailed hydrodynamic database (bhdb-file) is calculated. This extensive hydrodynamic database contains all the relevant hydrodynamic properties of the vessel for a range of drafts, speeds, headings and frequencies. The database contains:

- A definition of the geometry (3D)
- Radiation pressure distributions for the six modes of motion
- Diffraction pressure distributions for all wave headings

The hydrodynamic database can be calculated using any third-party 3D radiation/diffraction program. For ships with forward speed, DNV GL's 3D-radiation/diffraction program WASIM<sup>[3]</sup> is used. Since WASIM is a time domain program, it would be necessary to model an autopilot to simulate a course-stable ship in waves and to solve the motion RAOs directly. For our purposes, it is not necessary to model an autopilot because WASIM is only used to solve the radiation and diffraction problem in the time domain. Snapshots of such simulations are shown in Figure 2

2 Snapshot of a simulation of a forced heave oscillation to calculate pressure distributions for added mass and damping calculation

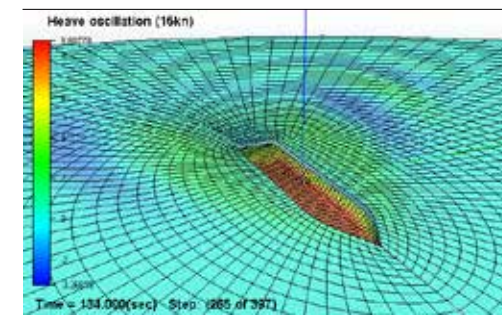

3 Snapshot of a simulation of a restrained vessel to calculate pressure distributions wave force calculation

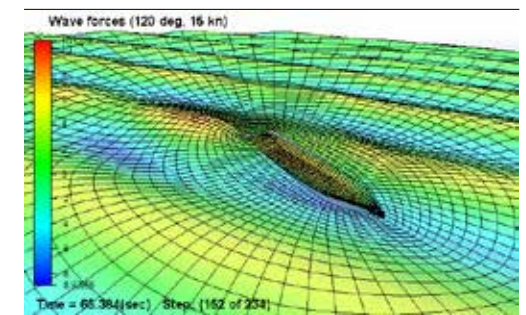

and Figure 3. The WASIM results of these particular simulations are transformed to the frequency domain by Fourier techniques. After that the pressure RAOs are converted to the OCTOPUS bhdb-format.

The final step is a reduction of the database to a compiled hydrodynamic database (chdb-file) by section-wise integration of the pressures stored on the bhdb-file. This results in longitudinal distributions of added mass, damping and excitation forces, which can successively be used to rapidly evaluate any intermediate draft and trim without losing accuracy. This has been demonstrated by Rathje et al<sup>[4]</sup>.

### The actual loading condition

Having the hydrodynamic database available for a series of drafts, the hydrodynamic coefficients and wave excitation forces can now be computed for a particular loading condition. The following steps are carried out:

- Calculation of the global mass parameters (total mass, CoG, radii of gyration, free surface moment). These parameters may be derived from the stability program (during design) or directly from a loading computer (during operation).
- Calculation of the equilibrium position by solving the draft aft and forward using the mass parameters in combination with the 3D geometry description stored in the database.
- Calculation of the added mass, damping and wave forces for the actual trim and draft, in which special care is taken for trimmed cases with respect to rotations and transformations.

### Viscous roll damping

Potential flow models need to be extended with viscous damping effects, otherwise roll motion will be overestimated. A popular method is Ikeda's roll damping method, which includes the following non-potential damping contributions:

- Frictional roll damping
- Eddy-making roll damping
- Lift roll damping coefficient
- Bilge keel roll damping

Since the viscous roll damping coefficient itself is a function of the roll amplitude and frequency, it results in a roll transfer function, which is nonlinear in the wave height. This implies that the linearized roll transfer function varies per sea state.

### Solution of motion equations

To account for the nonlinear viscous damping behavior, the sea state dependent roll RAOs are solved in an iterative manner by applying the principle of stochastic linearization, as shown in Figure 4. The viscous damping is estimated using a start-value for the roll motion. The result is a roll RAO. This RAO is used to calculate the roll angle in a particular sea state. If the roll angle is equal to the assumed roll (which is calculated by solving the equations of motions, including non linear effects of roll damping), convergence has been achieved. As long as convergence has not been reached, a new roll damping is computed using a larger or smaller roll angle, the roll RAO is recalculated and a new roll response in the particular sea state is calculated. This loop is repeated until convergence has been obtained.

4 Calculation of the roll RAO for one particular speed, heading and sea state by means of stochastic linearization.

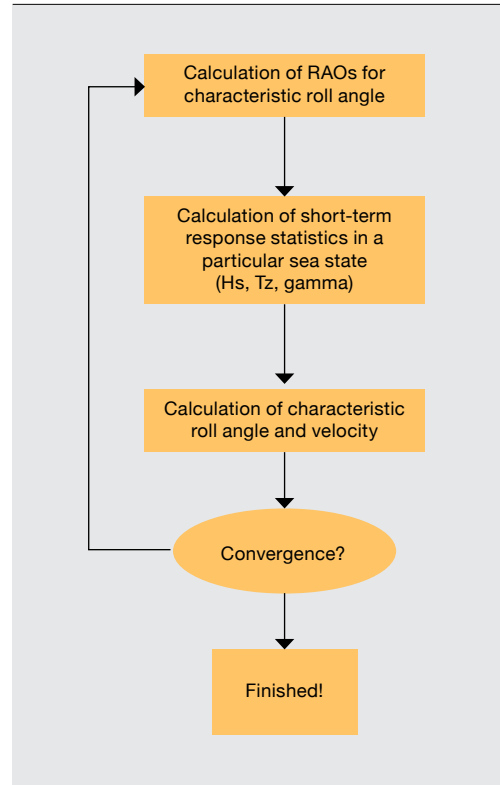

5 Calculated roll angle as function of the bilge keel height in a particular design sea state.

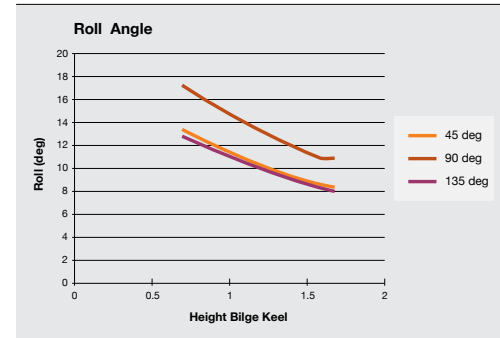

6 Calculated transverse acceleration as function of the bilge keel height.

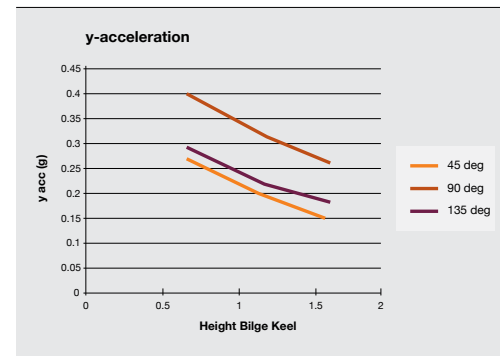

Since the design sea state is not known prior to the calculation of the roll RAOs, the roll RAOs are initially computed for a range of sea states with different wave periods and wave heights. At a later stage, the short-term response statistics can be calculated by combining the design sea states with the RAOs for the best matching sea states.

### Tuning of roll motions

Even when using the advanced approach outlined above, it may be difficult to achieve the required degree of correlation between measured and calculated roll motion or the related transverse accelerations. If model tests or full-scale results are available, a further tuning of roll motion or transverse acceleration can be applied.

This tuning of the roll angles or transverse accelerations can be done by modification of the viscous damping contribution. Since accelerations are the

essential input for cribbing and seafastening design, as well as for the calculation of, for example, leg bending moments, tuning to accelerations is often the objective.

A practical way to increase the viscous damping is to increase the height of the bilge keel. This has an immediate effect on the magnitude of the total roll damping in a given sea state. Figure 5 and Figure 6 show the calculated roll motion and transverse acceleration as a function of the bilge keel height. The physical explanation for increasing the bilge keel height to a larger artificial bilge keel is to account for effects, which have not been modeled in a common seakeeping model, but which have a similar effect as a bilge keel. By varying the bilge keel height, roll motion or transverse accelerations can be tuned. Of course, this procedure can only be applied if reference material in the form of measurements is available.

7 Illustration of the calculation of the leg bending moment in longitudinal direction

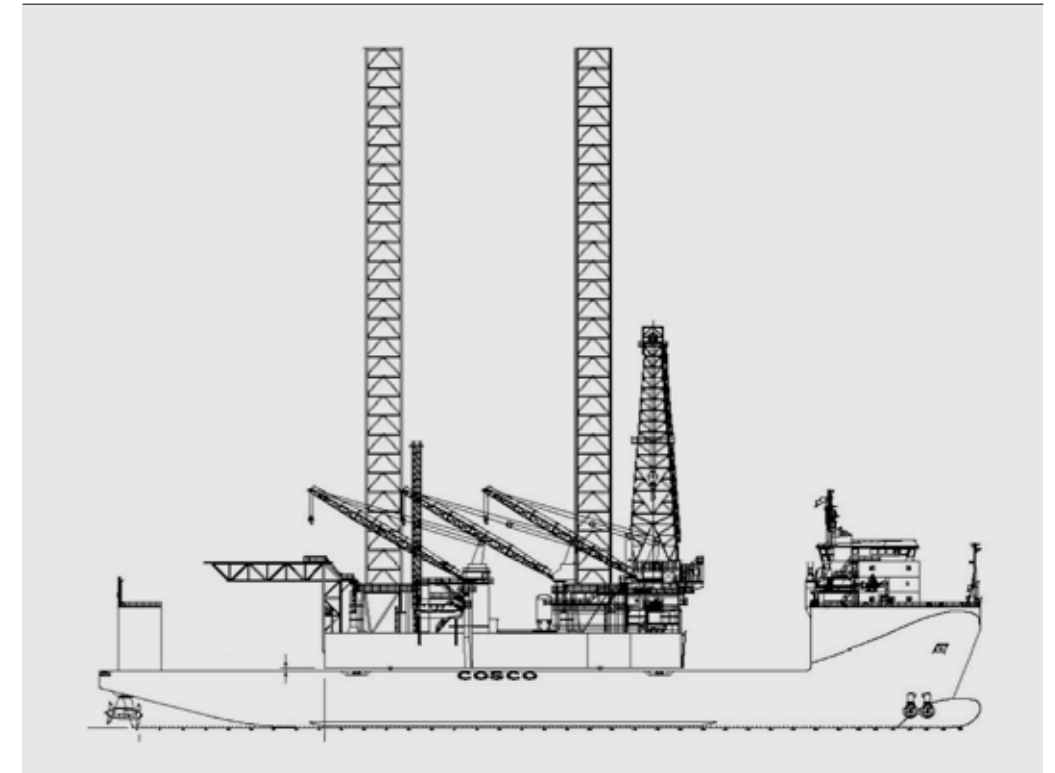

### Response combinations

By using the RAOs of the global ship motions, transfer functions of local accelerations or even leg-bending moments can be constructed. Combination of responses at the level of transfer functions guarantees the proper phase relations between the different response components, resulting in accurate and realistic response combinations.

An example of the definition of a leg bending moment in longitudinal direction is given by the following linear combination of responses (see also Figure 7).

$$LBM_x = \sum_{i=1}^N m_i h_i \ddot{x}_i$$

Where  $m_i$  = the mass of a leg element  $i$ ,  $h_i$  = the lever of the section under consideration, which is the distance between the section's CoG and the jack house, and  $\ddot{x}_i$  = the local acceleration in x-direction, which itself is a linear combination of basic ship responses (rigid body accelerations plus a gravity component due to pitch).

Combination of response on the level of transfer functions takes away the discussion of combination or correlation factors between response components. In general, the response maxima will be slightly lower than those obtained by simply adding up the maxima of the individual responses as is sometimes still done. A lower and thus less conservative result implies fewer lashings or sea fastenings (i.e., cost saving), or, when using the same sea fastening, a higher degree of workability.

### DESIGN CONDITIONS AND VALUES

#### Short-term response statistics

Short-term response statistics can be calculated by combining the design sea states with the best matching set of RAOs with respect to sea states (see Figure 9). By assuming a Rayleigh probability distribution, the Most Probable Extreme (MPE) is given by:

$$MPE = \sqrt{2m_0 \ln \frac{t}{T_2}}$$



8 A semisubmersible heavy lift vessel with rig on deck and OCTOPUS monitoring and routing system on the bridge



9 Procedure to short-term response statistics

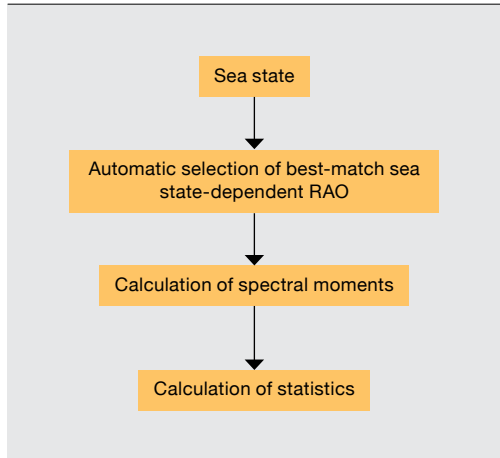

Where  $m_0$  is the spectral moment or variance of the response. The zero-upcrossing period

$$T_2 = 2\pi \sqrt{\frac{m_0}{m_2}}$$

and  $t$  is the reference period of a sea state, in seconds, typically three hours or 10,400 seconds. The significant amplitude of a response is given by:

$$A_{1/3} = 2\sqrt{m_0}$$

which implies that

$$MPE = A_{1/3} \sqrt{\frac{1}{2} \ln \frac{t}{T_2}}$$

The number of cycles in a three-hour storm depends on the average response period of the response cycle. Depending on the response and seastate, this typically varies between six and 30 seconds (for roll, for example). This would result in:

$$1.7 \times A_{1/3} < MPE < 1.92 \times A_{1/3}$$

#### The indicative optimum voyage

A meteocean study starts with making an indicative route plan. The master will decide on the final route plan later. Based on the route plan and the expected date of departure, the wind, current and wave statistics can be obtained. In this example, a route has been calculated using the weather routing package SPOS [8]. SPOS is normally used for daily weather routing advice. Route optimization based on ship motion behavior can also be carried out. A maximum of 10 days of weather forecast is available. For periods further ahead, wave climatology is used. The SPOS wave climatology is based on more than 50 years of visual observations collected by the World Meteorological Organization. The climatology database in SPOS has been organized per month. For each location, a monthly average condition is used. This means a monthly average current, sea and swell (significant wave height, zero-upcrossing period and mean direction).

Figure 10 shows a calculated trans-North-Atlantic route for June based on wave and current climatology: the statistical average wave and current conditions at

the time of passage. The route optimization has been carried out without considering motion criteria.

For each grid point and each point in time, the most likely significant height, period and mean direction of sea and swell are known. This information can be completed on the assumption of a JONSWAP spectrum shape with a gamma factor as a function of wave period and height, and a wave spreading function. For sea, a cos2 spreading function has been assumed. In case of swell, a cos8-spreading function was used.

With this information, short-term response statistics can be calculated for all headings and speeds. This provides the basis for calculation of an optimum route, taking into account maximum allowable response levels during the passage. The alternative route is shown in Figure 11. It is shown that in the same weather, a vessel specific optimum route is found much further south than the original route.

The result of this analysis is a route that statistically results in the fastest estimated time of arrival (ETA) and along which all the response criteria are satisfied. Relaxation of the criteria will result in a route that will converge to the Northern route, i.e., the route with fastest ETA if no other criteria are to be satisfied.

#### Design sea states

The design sea states can be further assessed using the indicative route in combination with a statistical wave database (Global Wave Statistics, ECMWF, those of classification societies, others). When the route plan is combined with wave scatter diagrams, a route-specific equivalent wave scatter diagram can be derived (Figures 12 and 13). From this, different methods are used to derive the extremes likely to be reached or exceeded once every 10 years, on average. A typical wave period range depends on the significant height of the design wave. Noble Denton<sup>(1)</sup> prescribes:

$$\sqrt{13H_s} \leq T_p \leq \sqrt{30H_s}$$

To calculate response statistics in waves, it is necessary to assume a spectrum shape. Often a Pierson Moskowitz or JONSWAP wave spectrum is used. Wave spreading may be applied.

10 The calculated optimum voyage from Rotterdam to Galveston without taking into account the seakeeping behavior. Red arrows indicate the area where one or more ship response criteria will be exceeded.

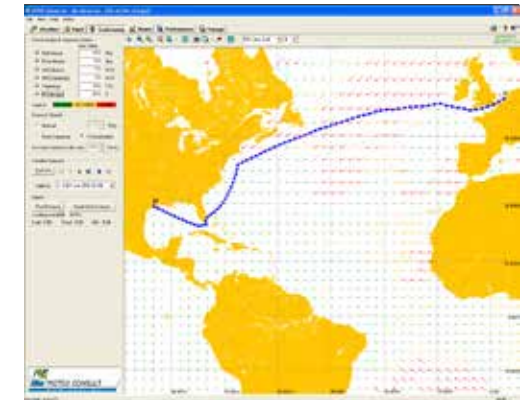

11 The calculated optimum voyage from Rotterdam to Galveston without taking the seakeeping behavior into account (Northern route) and with taking it into account (Southern route).

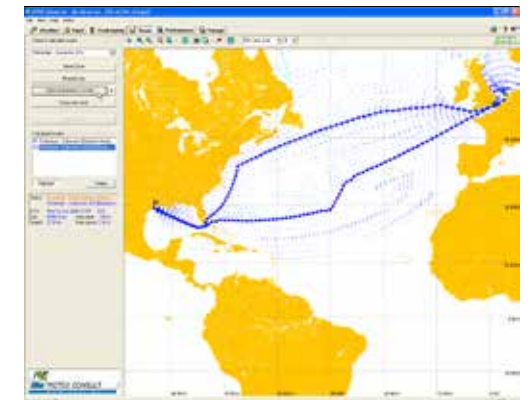

12 Matching of an indicative route plan with a wave scatter diagram database. The passage time per wave area is accounted for.



13 The route-specific wave scatter diagram.

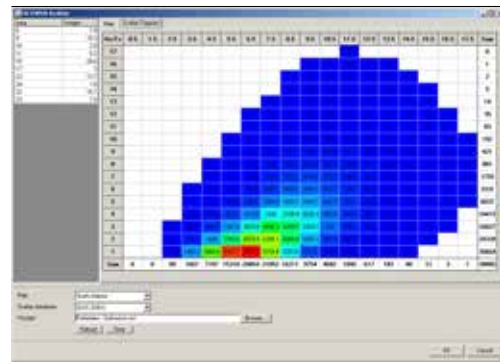

Depending on the duration of exposure and the availability of a wave forecast, some reduction of the design wave height may be allowed. Some further reduction of wave heights may be considered when directionality and heading control is possible. This is only the case for self-propelled vessels with redundant propulsion systems.

### Voyage simulations

More elaborate analyses can be carried out when time series of waves are available. Using spectral data instead of derived wave parameters such as significant wave height, mean direction or zero-upcrossing period, ensures more accurate results, especially in multidirectional seas. Moreover, persistency effects are automatically included.

Voyage simulations can be carried out, for example, by using the Argoss w3c-database [9]. This historical worldwide wave database is the product of satellite observations and a third generation wave model. It covers a period of 15 years with a time resolution of three hours. The wave condition at a particular date, time and location is described by a distribution of the energy, the direction and the directionality, as a function of the frequency. The position list of the indicative voyage can be used as input for voyage simulations. These simulations are carried out for different dates and times of departure, and repeated until convergence is obtained after 'N' simulations. The design values can be derived by defining a required success rate after simulating 'N' voyages. Risk mitigating measures are not accounted for.

An example of a tool in which risk-mitigating measures can be modeled is SafeTrans [10]. The SafeTrans software is an engineering tool to calculate design values for marine transports and installations. For operations design, SafeTrans includes a decision mimic, which allows the user to take into account ship master decisions about postponing tasks or going for shelter given the weather forecast.

## ONBOARD DECISION SUPPORT

### Onboard evaluation of responses

At some stage, the design values have been established, either by using calculations or simply from following rules or regulations. The seafastening

design is finished and the transport is ready for departure. From that moment, it is up to the master to make the final decision regarding the route, speed and heading, taking into account the transport-specific operational limits, the weather forecasts, other operational input and his seamanship.

In this section there is an explanation of how the outlined methods and information can be used by the master in immediate and mid-term decision support for heading control in bad weather and response-based route planning.

Often the design values may be directly taken as the allowable values during the passage. However, for safety or comfort reasons, it may be advantageous to try to avoid the severest allowable conditions. This can be done by using a safety margin, which is achieved by reducing the allowable response level, to, for example, 75 percent of the design value. Note that the safety margins may be different for each response.

The procedure for operational support onboard is very similar to the design procedure and includes:

- Automatic processing of the actual loading condition, obtained from the loading computer or specified manually
- Calculation of hydrodynamic coefficients and wave forces for the actual draft and trim, using the pre-calculated hydrodynamic database
- Specification of the responses of interest (absolute or relative motions, accelerations, leg bending moments, etc)
- Calculation of the RAOs
- Specification of the statistical quantity and the corresponding allowable value for each response of interest
- Calculation of short-term response statistics by using the available wave information (wave radar measurement, observation by the master or weather/wave forecast)
- Evaluation of the response levels or probability of exceed with respect to the allowable values or criteria
- Presentation of the results in a non-academic style that is easily accessible to the mariner

14 Design values can be used as criteria with or without a safety factor, which should be less or equal to 1.0

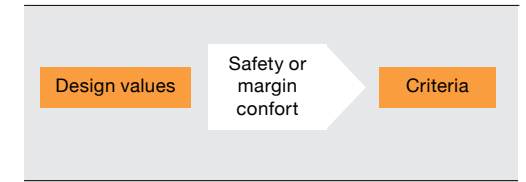

15 Analysis sequence for onboard decision support for safe and economic ship operation in waves

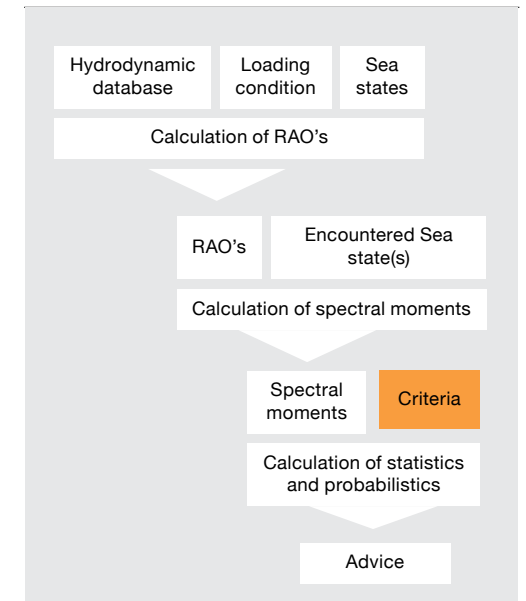

16 A polar diagram showing combinations of speed and heading that result in high (red) or low (green) responses, plus an indication of resonance areas according to the IMO guidelines [11]

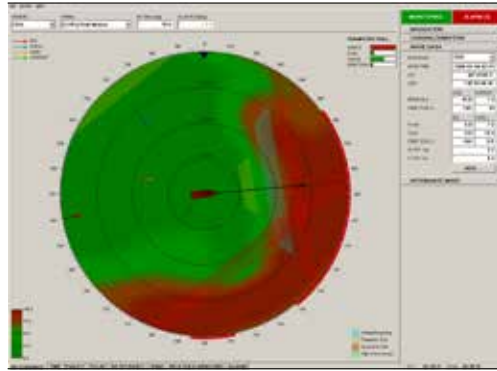

17 Display of weather windows after calculation of ship responses using the waves expected during a voyage plan



18 Comparison between measured accelerations and the calculated accelerations based on wave forecast (Dockwise heavy transport vessel)

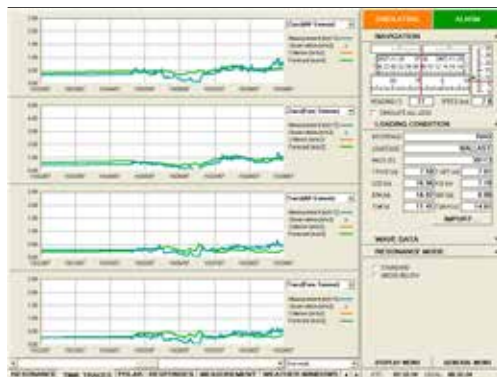

A flow diagram of the procedure is shown in Figure 15.

### Display of results

Effective onboard decision support in heavy weather requires that the ship responses have been calculated for all headings and speeds. The results for one particular sea state can be presented as a polar diagram (Figure 16) in which the radius of the diagram indicates the vessel speed. The same polar display can also be used to indicate resonance areas as formulated by the International Maritime Organization (IMO) [11]. After normalization of each response by dividing the calculated response by the allowable level, the condition in a particular sea state can be judged quickly, taking into account all the relevant responses simultaneously (the response envelope). For each speed and heading, the “maximum normalized response” (in terms of percentage of criterion) is evaluated. When below 75 percent, the condition is green; if it is over 100 percent, it will be red. Complex wave conditions like multidirectional confused seas as measured by wave-radar can be evaluated in the same objective manner.

In case of a weather forecast, weather windows can be calculated. An example is shown in Figure 17. The same normalization procedure as described above has been applied.

The successful implementation of these kinds of tools requires the acceptance of the system by the master and that he receives support from the office. Then a system that automatically calculates and updates diagrams like the examples in Figures 16 and 17 can and will be used to identify possible hazards and their consequences. The system will only assist the master to make the best decision for safe and effective ship operation in a particular condition, but ultimately the master takes the final decision himself.

Figure 18 shows a comparison between the measured accelerations (blue line) and the acceleration forecast (green line).

### Conclusion

A method for the robust and accurate calculation of ship responses in waves has been described. The ways of addressing the design values and how these

values can serve as input for an onboard advisory system have been explained. The following conclusions and recommendations can be made:

- Consistency between the ship response calculation methods used during engineering and operation is of importance and has been ensured in the presented approach.
- The concept of “allowable wave height” is difficult to apply since each response has its own “allowable wave height”, which finally results in a “minimum allowable wave height.” Application of the “minimum allowable wave height” as sole operational criterion could result in too conservative sailing behavior.
- Knowledge about the impact of waves on the ship for all headings and speeds, however, allows effective and objective operational decision support with respect to speed, heading and route. This is not the case in the “allowable wave height” concept.
- The tools are available to calculate responses on board with the same accuracy as when using state-of-the-art engineering tools in the office. Implementation of the presented method has resulted in an effective proven operational support tool for heavy transports over sea.

**Leon Adegeest**

Managing director, Amarcon, Netherlands  
leon.adegeest@nl.abb.com

### Acknowledgements

The following companies are acknowledged for allowing the presentation of information in this paper: NMA Maritime & Offshore Contractors, Dockwise Shipping B.V. and Offshore Heavy Transport AS.

### Notes

1. Noble Denton (2005). *General Guidelines for Marine Transportations*, 0030/NDI REV 2.
2. DNV GL (2008). *Rules for planning and execution of Marine Operations*.
3. DNV GL (2005). *WASIM User Manual*.
4. Adegeest, L. J. M., Drakogiannopoulos, J., Rathje, H. (2003). *Concept and Implementation of an Innovative Shipboard Routing Assistance System*, RINA Conference Design & Operation of Container Ships.
5. Amarcon (2007). *Manual: Calculation of an OCTOPUS hydrodynamic database using WASIM*. Amarcon, document M20070622.
6. Melger, F., Adegeest, L. J. M. (2006). *Connecting satellite data to decision support systems*. Agency for Aerospace Programmes, Report nr. A430/NIVR 53502AR.
7. Amarcon (2008). *Manual: OCTOPUS-ONBOARD User Manual*. AMARCON document.
8. Meteo Consult (2007). *SPOS Manual*, version 6.
9. DNV GL Class Note 30.5. *Environmental conditions and Environmental loads*.
10. Aalbers A. B., Nataraja R., Anink S. (2005.). *Design criteria for weather routed transport*. RINA Heavy transport and lift conference, London.
11. IMO (2007). *Revised guidance to the Master for avoiding dangerous situations in adverse weather and sea conditions*. MSC.1/Circ.1228.
12. Journee, J. M. J. (2001). *Verification and Validation of Ship Motions Program SEAWAY*. TU Delft Report 1213.
13. Adegeest, L. J. M. (2008). *Response based weather routing and operation planning of heavy transport vessels*. RINA Heavy transport and lift conference, London.



# Design point can hinder propulsion potential

**HENRIQUE PESTANA – Design point has been the mantra of naval architects for some time. Although a subjective concept, design point is broadly a set of parameters around which a ship is designed and in a way that reflects the mission intended for that specific ship. However, designing and building ships that are more flexible in term of these variables might be a better option.**

Along with cargo capacity (normally referred as deadweight), speed is one of the most important variables because it affects the transport capacity. The transport capacity of a fleet is a function of its cargo capacity and speed. Any change to these two variables has implications on the supply of that fleet, often measured in ton-mile, and potentially on the freight rates. This is probably why shipowners have always dedicated so much time to deciding on the right speed for their next vessel. On the surface this might sound awkward, but there is a big difference between 13 and 14 knots in power terms.

Once the speed – among the other design parameters – is defined, the designer runs a series of iterative calculations around the different elements of ship design: structure, stability, propulsion and so forth. When it comes to propulsion, the designer seeks optimization of the propulsion plant so that the vessel can achieve the design speed with the minimum amount of fuel, that is, maximization of the overall propulsion efficiency at a certain draft/deadweight. Consequently, if the ship operates outside of the

design point, the propulsion plant will not work to its full potential. In order to evaluate the impact of this insight, we need to evaluate how often ships operate outside their design point.

For this purpose, it is worth looking into three different types of operation:

- A. Ships that operate consistently at their design speed and design draft
- B. Ships that operate at a different draft from their design draft
- C. Ships that operate at a different speed from their design speed

## Ships that operate consistently at their design speed and draft

One of the key parameters for the design of the propulsion plant is the effective power (PE), which is the necessary power to move the ship with a certain draft at a certain speed (normally the design draft). Not long ago, estimating the effective power was a complex and non-exact affair, which required tank test validation if risk mitigation was sought. However,

in today's world of power computers, most designers have access to computer fluid dynamics (CFD), which adds considerable reliability to the power estimation process.

Nevertheless, power estimation techniques are not yet able to accurately calculate the effect of weather and waves, and even if they did, the weather conditions that a given ship faces over its lifetime is so diverse that such calculations would not add much precision to the end result. Consequently, the industry has tackled this effect by adding an empirical margin to the required power. This margin is known as the sea margin (SM) and is normally within 10 to 20 percent.

As a result, the installed propulsion power – usually referred to as break power (PB) – is calculated as follows:

$$P_B = \frac{P_E}{\eta} + SM$$

where  $\eta$  is the total propulsion efficiency

By adding the sea margin, it is possible to maintain the design speed up to a certain level of added resistance due to sea and wind. Consequently, when the added resistance from sea and wind is low or even negligible, the required power to maintain the design speed is much less and therefore the propulsion plant operates away from the design point.

There are, however, other factors that affect the overall resistance and thus the power demand. Examples of some of these factors, which are accounted for in the sea margin, are:

- Trim
- Fouling of the hull
- Roughness of the propeller blades
- Use of lifting devices such as rudders and stabilizers

Most ships face frequent variations of weather and sea conditions, and their hulls accumulate fouling and their propellers lose efficiency over time. Consequently, even a ship that operates at a constant speed does not operate at constant power and, therefore, operates most of its life outside of the

1 Additional resistance from different external factors

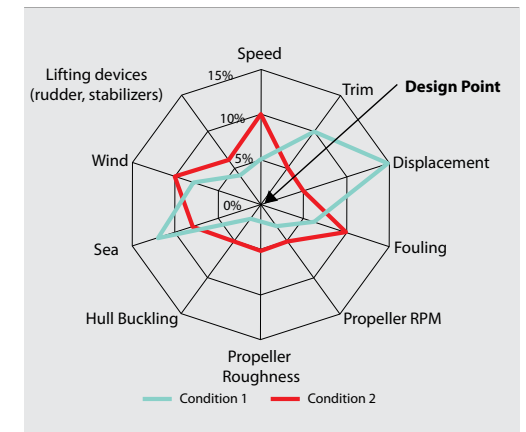

design point, whatever that may be. This point is illustrated in Figure 1, where different external factors add to overall resistance in different combinations, depending on the operating condition.

## Ships that operate at different drafts.

A tanker with a deadweight of 160,000 tons at a draft of 17 meters (the typical size of a Suezmax ), for example, will require power of about 15.6 MW at a speed of 14.5 knots (including a 15 percent sea margin). However, when sailing in ballast condition with a displacement of about 75,000 tons, the same vessel will only need about 8.6 MW to reach the same speed in the same sea and weather conditions. Even assuming the weather and sea effects – as well as the others listed above – are constant, the power requirement for the ballast leg is about half the power requirement for the laden leg. Traditionally, these vessels operate at a higher speed when sailing in ballast, but still at considerably lower power levels. Typically, the power requirement for the ballast leg is about 20 percent less than for the laden leg.

Thus, vessels that operate at different drafts, like tankers and bulkers, operate outside of their design point, not only because they are exposed to the same external effects described above – weather, sea, fouling, etc. – but also because they operate at a lower draft for half of the time.

## Ships that operate at different speed

Container carriers are required to meet tight schedules so that the overall logistics chain runs smoothly

2 Draft histogram of a modern 30,000 DWT MPP operating over a year

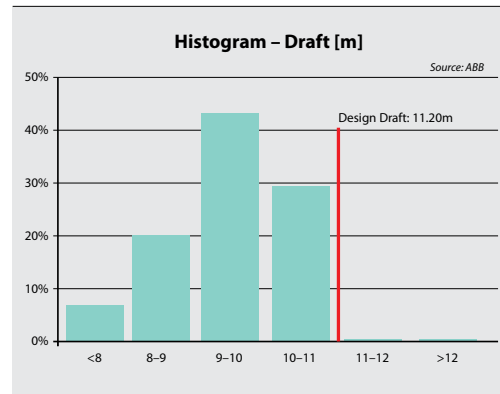

3 Speed histogram of a modern 30,000 DWT MPP operating over a year

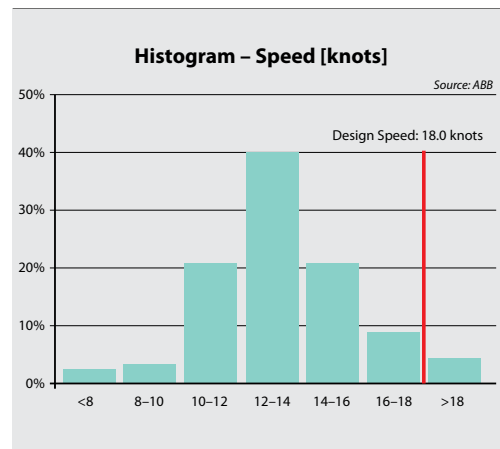

4 Main engine output histogram of a modern 30,000 DWT MPP operating over a year

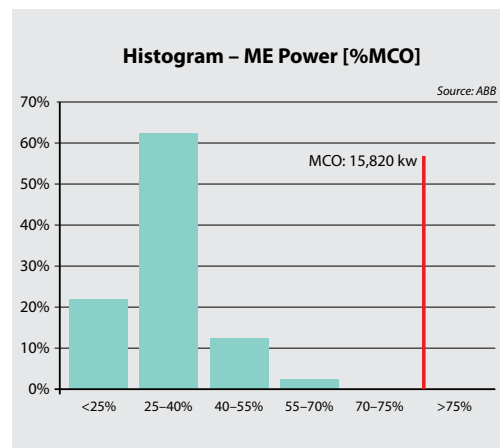

and efficiently. This means that a ship might sail each leg at a different speed on a round voyage. A large container carrier typically has a top speed of 24+ knots and spends most of the time sailing between 14 and 22 knots. The histograms below show how often a modern 30,000 DWT multipurpose ship (MPP) operates outside its design point for draft, speed and power for a year. The vessel operated at a lower than design draft most of the time and below 40 percent of the design point engine power for more than 80 percent of the time.

In all three types categories of operations illustrated above, the propulsion power required to move the ship at a certain speed, with a certain draft under specific conditions, varies considerably. This means that the vessel operates more than often outside of its design point. However, the majority of ships are designed and built to meet a certain energy efficiency (normally measured in daily consumption) at the design point for draft and service speed.

When a vessel is built at design point, every system is designed to maximize the overall efficiency at that point. In other words, if a 160,000 DWT tanker is designed to operate at 15.5 knots, both the hull shape and propulsion plant are designed to minimize the fuel consumption at that speed and draft, taking into consideration a certain sea margin for the added resistance from sea and weather. That means the overall propulsion efficiency is maximized at that point leading to lower efficiencies when operating outside of it.

#### A new era of flexibility

Shipbuilding contracts specify what the consumption of the vessel at the service speed should be and thoroughly prescribe methodology to access such consumption. However, a shipbuilding contract rarely specifies consumption at a wide speed and draft range in a legally binding way. Even chartering contracts are very specific on the fuel consumption the vessel should attain at the service speed and design or maximum draft.

However, the industry has witnessed some changes in recent years that are making shipowners, charterers and shippers look at fuel efficiency in a new light. One such change is the development of the relative cost of fuel.

5 Relative cost of fuel of a Suezmax tanker

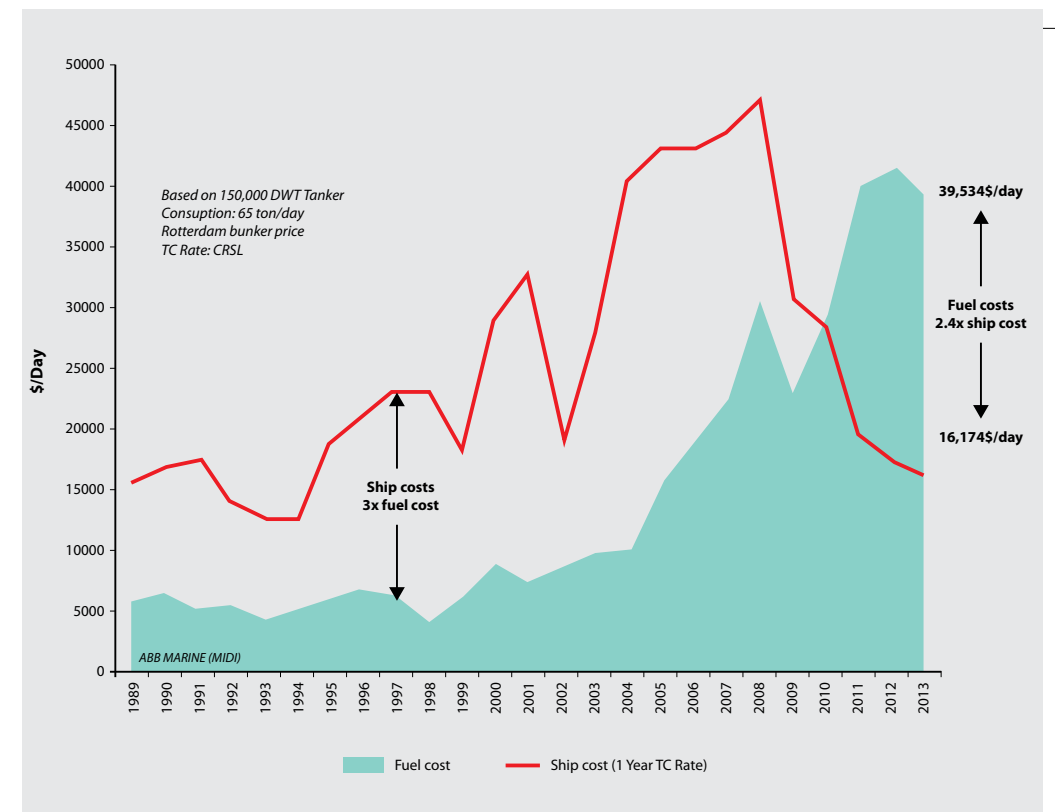

Figure 5 illustrates the development of the fuel cost for a Suezmax tanker over the last 24 years. From 2009 onwards, the cost of the fuel compared with the cost of the vessel increased dramatically. Such scenarios have, for the first time, put the topic of fuel efficiency on the agendas of senior executives leading the industry into a new age. Although most shipowners are now very sensitive about fuel efficiency, leading shipowners are already looking into how to spread fuel efficiency over a wider operational range. In other words, how to design and build ships that are more flexible.

#### Trends in ship design

The need for more flexible ships has led some shipowners to engage designers to come up with new solutions. One of the emerging trends is the optimization of the hull shape around more than one design point. In other words, the hull shape is designed to achieve a balanced efficiency based on a number of

operating points rather than attain the least possible fuel consumption at a single draft and speed.

There are, however, other tools to achieve more energy efficiency at a wider operational range. By combining a two-stroke diesel, gas or dual-fuel engine with an electric motor, it is possible to improve fuel efficiency at a wider range of operating points.

**Henrique Pestana**

Head of Ship Design, ABB Marine, Norway  
henrique.pestana@no.abb.com

# The technology that makes “floating gas pipelines” so reliable

**JAN-FREDRIK HANSEN, JAROSLAW NOWAK, HENRIQUE PESTANA – With the world demand for natural gas on the rise, LNG carriers keep the global economy turning. ABB technical experts explain the technology behind these advanced vessels that enable them to provide the world with a regular supply of gas.**

The global consumption of natural gas has increased considerably in recent years. In 1990 it was 1,768 million tonnes of oil equivalent (mtoe), compared with 2,987 mtoe in 2012. According to BP’s latest Energy Outlook, the consumption of natural gas is expected to reach 4,631 mtoe in 2035, as shown in Figure 1. By then, and for the first time ever, the consumption of natural gas will be as much as that of coal and oil – about 25 percent of global energy consumption.

The increased consumption of natural gas is mainly driven by lower price, as compared with other fuels, but also by its environmental footprint – the combustion of natural gas releases much less CO<sub>2</sub> per energy unit than other fossil fuels.

As of today, about 90% of the gas produced worldwide is transported by pipeline from the gas field directly into the consumers’ location. In 2012, world production of natural gas was 3,364 billion

cubic meters (bcm), of which about 70 percent was consumed within the country of origin. The remaining 30 percent was exported to other countries both through pipelines – 706 bcm – and shipped by sea – 328 bcm. Although the amount of natural gas transported by sea only accounts for 10 percent of world consumption, this is significant share of the natural gas traded between countries –, about 32 per cent. In order to make the sea transport of natural gas effective, and therefore economically feasible, it needs to be converted into liquid, known as Liquefied Natural Gas (LNG). The liquefaction of natural gas is possible by lowering the temperature of the gas to –163°C. The cooling process occurs at complex liquefaction plants located at deep sea ports and connected to the gas fields by pipeline. Once in liquid state, the LNG is then transferred into an LNG carrier. In order to safely transport 180,000 m<sup>3</sup> of gas at –163C across the ocean, LNG carriers have complex and unique systems – for example, cargo containment, cargo cooling, regasification, electrical propulsion, etc – that comprise a technologically advanced vessel.

On the other hand, these vessels are no longer expensive machines used to transport small parcels of gas that cannot be transported by pipeline. They are becoming an important part of the natural gas logistics chain. Consequently, LNG carriers are required to perform to very high standards of reliability so that the gas is delivered on time without compromising safety of life, the environment and the cargo.

Some LNG carriers are built for a specific trade, and are therefore designed for a very specific mission. However, the increased dynamics of this market, and the tendency for the commoditization of these vessels, suggests that flexibility is likely to become the most appreciated feature.

The first LNG carrier with electrical propulsion was ordered in 2003 and delivered from 2005 and onwards. Since then, the use of electrical propulsion has increased rapidly, with about 17 percent of the existing fleet equipped with electrical propulsion. However, it appears that this is only the beginning of the story since 71 percent of the LNG carriers on order will be equipped with electrical propulsion, as shown in Figure 2.

## Electric propulsion for LNG carriers

ABB is the largest supplier of electrical propulsion systems for LNG carriers. The advanced power solution developed by ABB Marine for LNG carriers is based on ABB’s highly reliable portfolio of generators, switchboards, transformers, variable speed propulsion drives and motors. These components are combined together with an advanced protection and power management system specifically developed for this type of vessels.

LNG carriers meet the most stringent requirements for regularity and reliability in delivering the gas to the destination on time. Electric propulsion and control systems are vital installations with built-in redundancy to minimize the risk of interruption of the transportation.

Electric propulsion technology has replaced the traditional steam turbine system. This was a well proven and reliable solution for LNG carriers, which used excess gas from the cargo tanks in boilers to produce steam. However, some years earlier, engine makers had launched power plant combustion engines able

1 World fuel consumption in million tonnes of oil equivalent

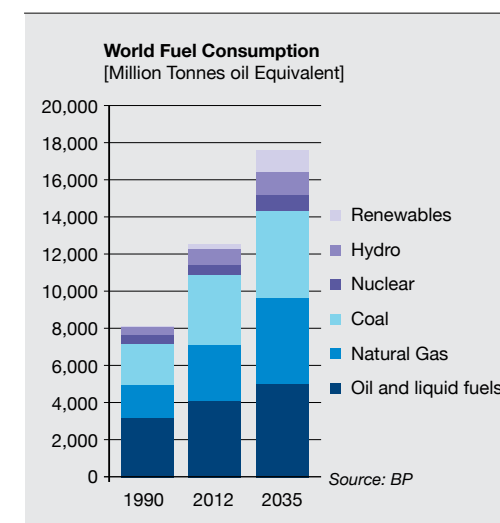

2 Share of electric propulsion in existing fleet and in present order book

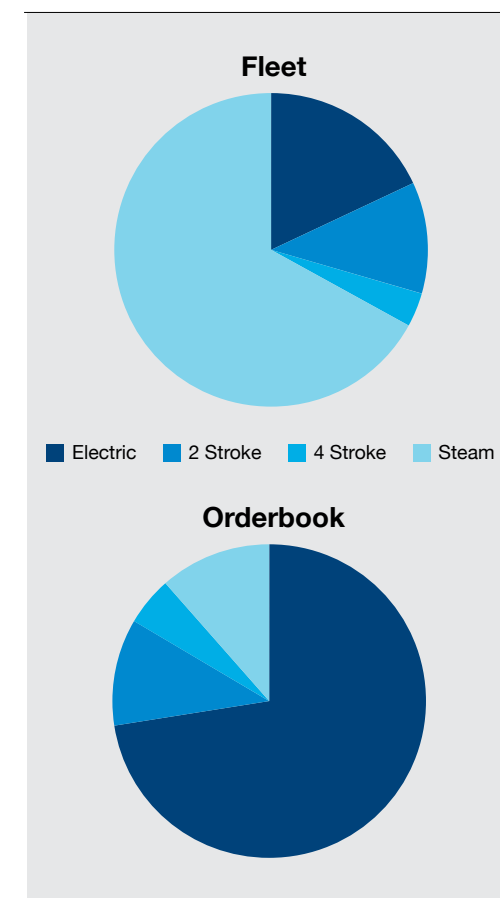



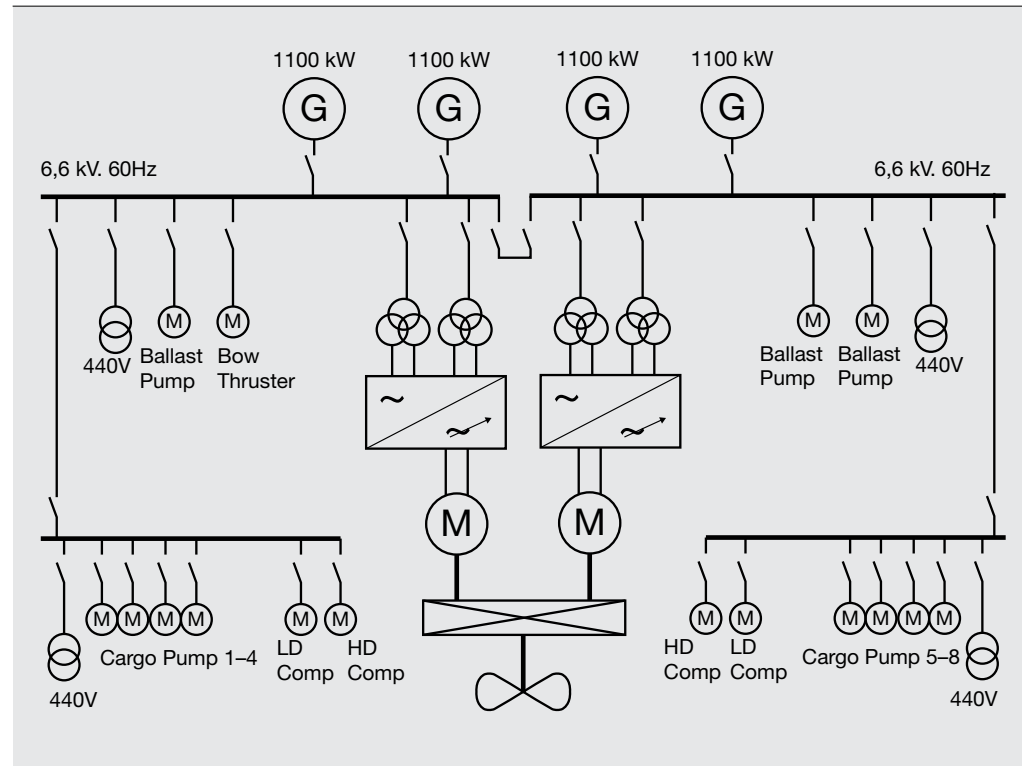

to use both diesel oil and gas as fuel – so-called dual-fuel engines. These engines are superior to the steam turbine system in terms of efficiency and, combined with electric propulsion, this system also developed the necessary reliability to meet the ship-owners' and charterers' most stringent requirements for the regularity of their fleet of LNG carriers. So when the first new propulsion system was ordered in 2003, others followed almost immediately with new orders. By 2005, almost all newbuild LNG carriers of standard size (140 000 cbm to 180 000 cbm) were ordered with the new propulsion system. A lot of effort was put into making the design as robust as possible and providing the required redundancy to meet the requirements. During the last 10 years of operational experience, the system has proved itself by the fact that today the majority of newbuild LNG carriers are still using the same system.

During the first years of development, the main focus was on the power and propulsion plant itself and, with small variations, the configuration has been the same for all vessels: two variable speed

electric propulsion motors (total propulsion power in the range of between 20 and 30 MW), each fed by dedicated frequency converters. Figure 3 shows the typical layout. The power plant has been configured by four or five engines in the range between 5 and 12 MW, and using a system voltage of 6,6kV. Since electric propulsion in itself was not new, all components and configuration were available from other vessel types. Most effort was put into the control system and adapting it to this specific application. The main difference between this vessel type and others that use electric propulsion (for example, cruise liners) is, firstly, the use of gas as fuel. The power plant thus has different characteristics, particularly for handling load variations from the propulsion plant, as the engines have a slower response to transients in gas mode than in liquid fuel mode. Secondly, these vessels act as a long distance pipeline and end consumer expect them to provide a regular supply of gas. This means these vessels have very strict time slots on the way to the terminals, setting high requirements on the availability of the power and propulsion plant.

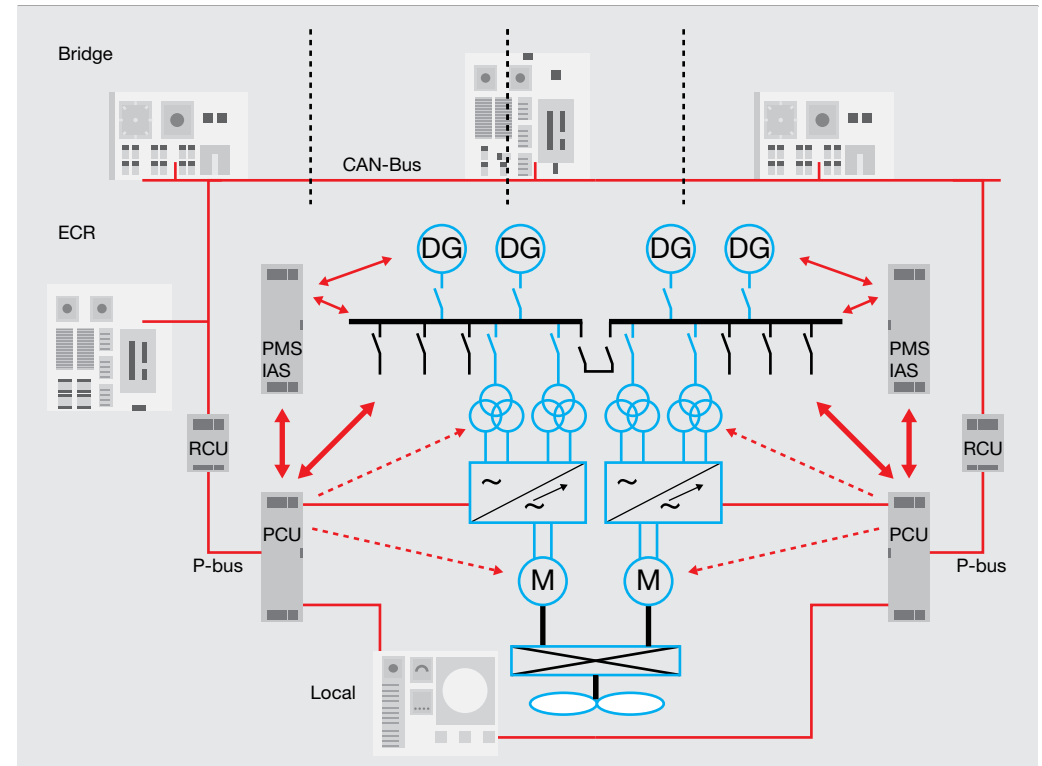

While the second challenge is mainly addressed by hardware, multiple configuration of components as motors, converters and generators, the first issue is basically addressed by the propulsion control system and its application software. This control system is designed to handle all kind of combinations of running generators and fuel usage. In the most complicated scenarios, we can imagine that one or two engines are running on gas, while others are running on liquid fuel, and this can change back and forth for several reasons. For example, ambient temperature determines the amount of boil-off available, and there may then be different scenarios of running the power plant either with mixed fuel or combinations.

All these scenarios have different characteristics and the challenge is to combine all this in an intelligent way in the control system in order to simplify the user interface into simple start/stop buttons and levers for speed and power control. A typical propulsion control configuration is shown in Figure 4.

Another task for the propulsion control system is the blackout prevention function. This is achieved by a combination of relatively simple power availability limitations to more advanced limitation based on various parameters from the stability of the power plant and quality of the gas fuel to the engines. However, the important thing here is having fast communication between the "brains" of the power plant (the protection relays) and the "brains" of the propulsion part (frequency converters/propulsion control). Having a proper interface here and using the best practices available, it is fully possible to obtain a good blackout prevention system. Figure 5 is an excellent example of this. The figure was recorded from a sea-trial for an LNG carrier with four generators, 3 x 11MW and 1 x 5.5MW. All three generators were tripped intentionally one by one in order to fully test the system and, even when the last one was tripped leaving only the smaller generator online (5.5MW), the propulsion system was fast enough to reduce the propulsion power and keep the power plant alive, while still having enough power for safe maneuvering.

### 5 Records from blackout prevention test

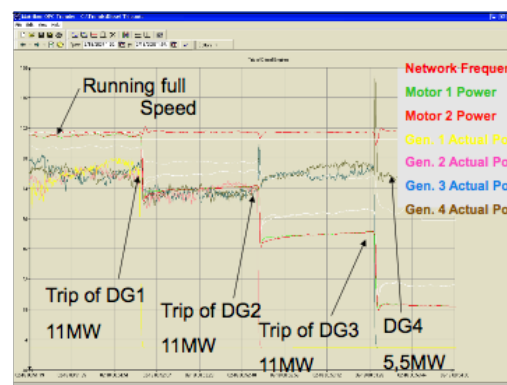

When a case is under discussion, it is natural for the operator is to navigate to the maintenance workplace screen and read the exact fault message generated by the intelligent device itself (frequency converter), together with all the troubleshooting hints associated with it.

If the crew onboard is familiar with the equipment and, based on the information received from the maintenance workplace, is able to fix a faulty component, the rectification process ends at this point and the system is put back to operation. This may not, however, be the case if the reason for the trip is unknown. Calling service specialists from the original equipment vendor may be required in this case and will undoubtedly lead to even longer downtime and additional expenses.

This can, however, be avoided. Modern, advanced integrated automation systems can be equipped with a secure, satellite link to the onshore support center that can be used by the same service specialist within minutes of a request. The support engineer would, in this case, look into another layer of the automation system – a diagnostic and monitoring system specifically designed to continuously collect all necessary, high resolution measurements from critical components.

The principle of data logging and analysis that takes place at the diagnostic level of the system involves taking all the advantages of intelligent devices (such as protection relays, frequency converters and PLC controllers) and using them exclusively for troubleshooting and condition monitoring. The successful introduction of advanced diagnostic techniques depends on the availability of good quality, high-resolution measurement data that typically cannot be provided from the legacy control systems. On the other hand, since physical wiring and cabling is usually limited to interfaces defined for control and protection purposes, the scope and quality of available signals is quite limited at the upper level of the control and automation system that can be effectively used by a diagnostic system for detailed troubleshooting and advanced condition monitoring.

The solution is the use of communication protocols such as IEC 61850, together with all the additional

In recent years, the power and propulsion plant has been supplemented with equipment enabling remote monitoring and diagnostics. This has been achieved by tailoring some special computer systems to communicate directly with the equipment on board, accessing all possible variables and parameters. This system started with the frequency converters, which are the most advanced components onboard, but also the easiest to repair if the fault can be located. This system enables an ABB engineer to address various issues remotely, and guide the crew to do corrective actions before the situation becomes critical in terms of keeping to the ship schedule, etc. The system was later expanded to also include monitoring of control systems and protection relays and is today under continuous development to handle the complete set of equipment defining the total power and propulsion plant for LNG carriers.

Figure 6 offers a closer look at the building blocks of an advanced monitoring and maintenance system and how the information is shared between different layers of the integrated system, taking all advantages of intelligent devices, protocols and condition monitoring techniques.

Examples of diagnostic solutions are related to the monitoring of the electric power-drive train system on its component and subsystem level. In practice, the monitoring system for electric propulsion can be delivered with or without integration to upper automation system.

### 6 Remote diagnostic and monitoring system

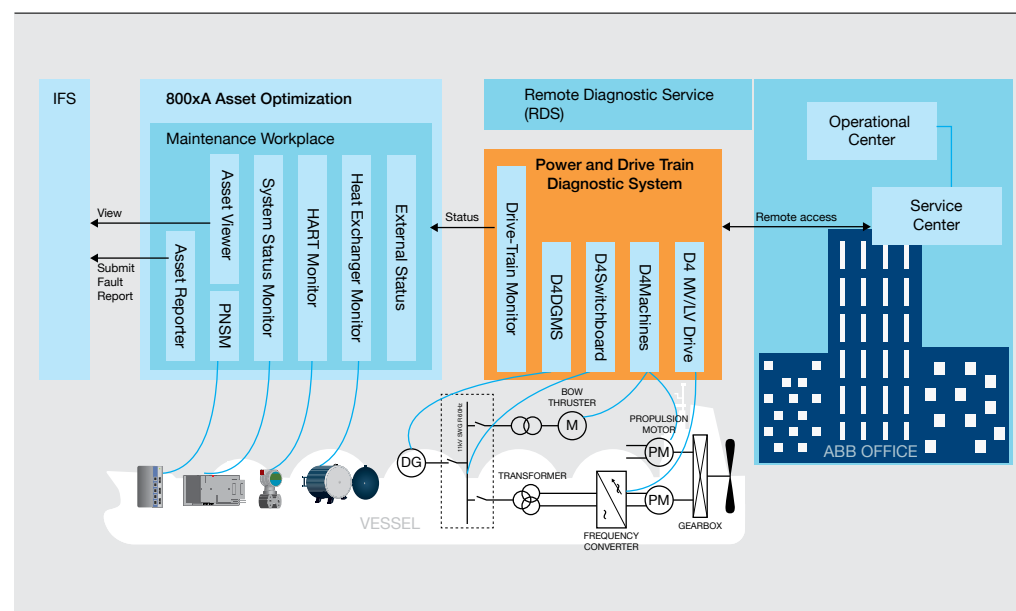

means of connectivity that modern intelligent devices offer. In the fault rectification scenario presented earlier, the same support engineer would access high-resolution data loggers (sampled with, for example, 10kHz) that were recorded by the device at the moment it was tripped and stored for further fault tracing analysis by the diagnostic system. Such an analysis, remotely performed, would identify the root cause of the problem and lead to rectification and restarting of the system in the shortest possible time.

Events and transient recorders from each individual protection relay are uploaded to the diagnostic system and presented on the same chart having a common time axis. Since protection relays implement SNTP time synchronization and are synchronized to the same master clock, the analysis of electrical fault propagation across the MV switchboard can be done at the system level with the time span manipulated from single milliseconds to several seconds.

**Jan-Fredrik Hansen**  
Technology Manager, Centre of Excellence Oil & Gas Vessels, ABB Marine, Norway  
jan-fredrik.hansen@no.abb.com

**Jaroslav Nowak**  
Global RDS4Marine Product Manager, ABB Marine, Norway  
jaroslav.nowak@no.abb.com

**Henrique Pestana**  
Head Ship Design, ABB Marine, Norway  
henrique.pastana@no.abb.com

# Quality upgrades can meet stricter closed bus rules

**ØYSTEIN HÆHRE – Most drillships and semisubmersible vessels can upgrade to meet the new requirement for closed bus operation with the same high safety and reliability as newbuilds.**

Throughout the shipping market demand has stepped up for vessels with improved functionality and technical solutions that reduce maintenance cost and improve fuel economy. Against this background, DNV GL and ABS have released new rules that require a vessel to achieve high safety and reliability when running with a closed bus configuration.

DNV GL and ABS have one set of rules and notations for closed bus operation. Demand for newbuilds that comply with the new class requirements is increasing, as is interest in upgrading existing vessels to comply with these new rules.

Class rules have become much stricter. ABS now requires vessels to meet part of the EHS-P notation to be allowed to run with closed bus configuration. The new rules are also putting more responsibility on the power system integrator, with the need to prove that the delivered system can meet the necessary reliability and safety requirements. This involves more testing, dynamic simulations and extensive FMEA analysis.

Most of the sailing fleet can upgrade to meet the new requirements with the same high safety and reliability as new vessels. The technical requirements for DP3 closed bus and enhanced notations have many similarities, but the strictest one is the DNV DYNPOS AUTRO Closed Bus.

Many of the class requirements for the closed bus operation are quite similar, but the main ones are:

- Protection on the HV switchboard and improved functionality with zone protection
- Hidden failure monitoring of the protection system
- Enhanced generator protection
- Arc protection or insulated bus for the HV switchboard
- Blackout recovery time and procedure
- Pre-magnetizing of the transformers where high inrush currents are a problem for fast restart after blackout
- Fault ride-through
- Autonomous generator
- Autonomous thruster systems

1 Marine SWBD Design Short Circuit Zone Protection

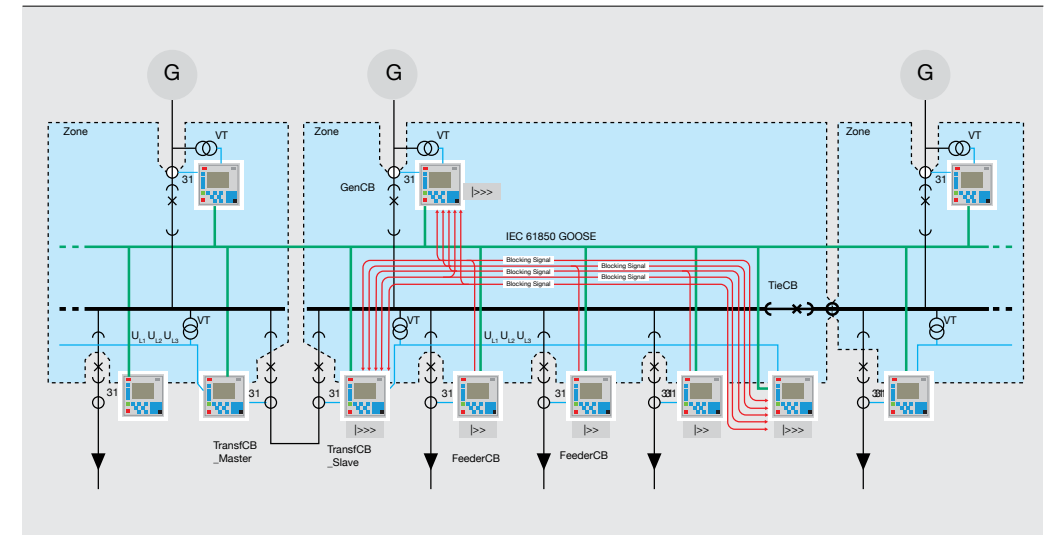

2 Diesel Generator Monitoring System

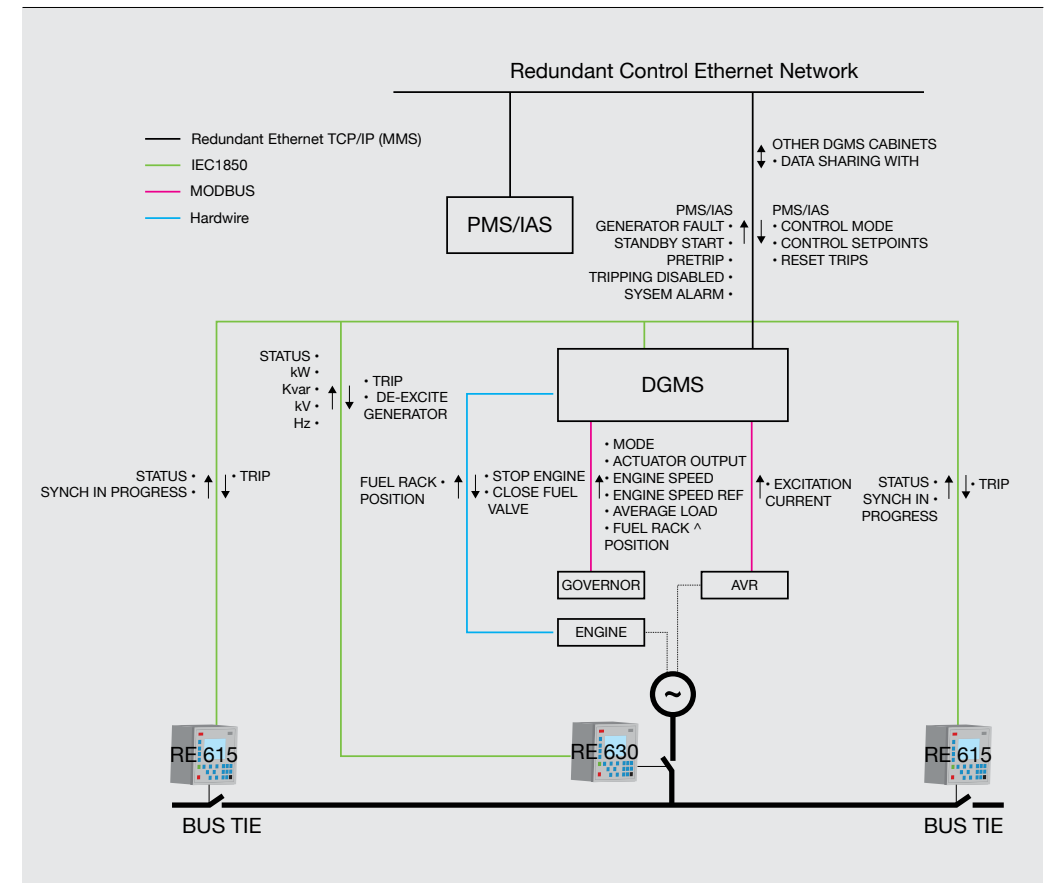



3 Engine and Thruster Auxiliary Power Distribution showing supply transformer for thruster and diesel-generator auxiliary for each redundancy group

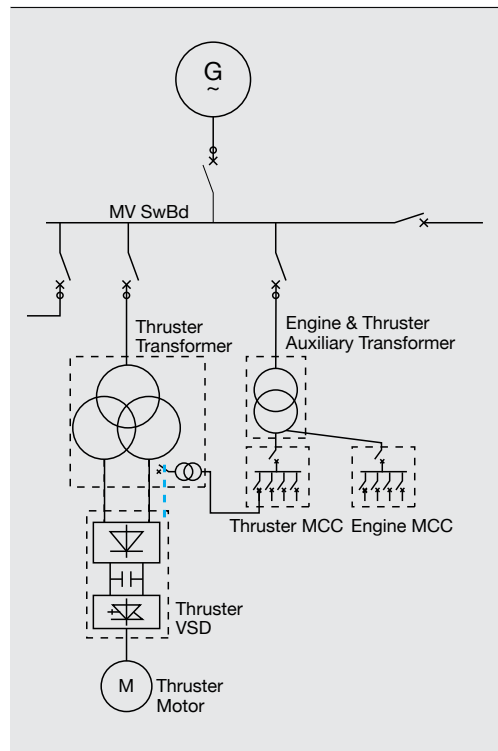

To get a better understanding of how to upgrade a sailing vessel with an ABB power and thruster system to, for instance, DNV DYNPOS AUTRO Closed Bus, we take an example from a typical drillship. Let us consider a drillship with six generators, six thrusters and six distribution transformers equally shared between three HV switchboards, and with three redundancy zones with A60 walls. All of the switchboards have two transfer lines/bus-ties that allow them to connect in ring, and we also make the assumption that the vessel has an HV switchboard with REM545/REF543 protection relay, fast recovery after blackout for the ACS6000 thruster drive, but no pre-magnetizing of the transformers.

### Change to new generation relays

If we start with the HV switchboards, the REM545/REF543 protection relay can meet the zone protection and arc protection requirement by adding some CTs and arc protection to all of the compartments, but the self-diagnostics to find hidden failure are not available for this type of relay. Therefore, the relays must be changed to the new generation relays, RELION REM 630 and RELION REF 620. These relays are based on data communication peer-to-peer with GOOSE from the IEC 61850. Protection is block-based with time-delay protection as a backup, built-in hidden failure monitoring and the ability to communicate directly with the drilling drive and thruster system for immediate and precise load reduction in case of generator feeder trip.

To meet the enhanced generator protection, the ABB Diesel Generator Monitoring System (DGMS) will be implemented. The DGMS will monitor the generator and the diesel engines for abnormal conditions and will be able to take action before a failure happens, be it a failure caused by over/under fueling, over/under excitation or an active and reactive power output, etc. Since this is seen as an extended part of the protection system, the DGMS should be delivered by the HV switchboard supplier.

In the event of a blackout, the transformers will be closed – preferably at the same time – to reduce the recovery time after blackout. To reduce the stress on the generators and the voltage drop during inrush, pre-magnetizing of the transformers should be implemented for the large HV transformers. This will also

allow for an integrity check of the transformers before they are connected, which will avoid the connecting of a faulty transformer. If pre-magnetization is required, this must be evaluated on a case-by-case basis during pre-engineering.

Fault ride-through depends on essential HV and LV breakers not opening during a voltage drop when there is a short circuit. This is not a problem for the HV switchboard, but for the LV switchboard, a study must be done to evaluate the fault ride-through capability and adjustments must be made accordingly.

In an autonomous generator and thruster system, control and automation functions are decentralized. This means the auxiliary, electric auxiliary and water-cooling must be connected only within the same redundancy group and must not be dependent on external automation outside the redundancy group to be able to restart after blackout. For a drillship or semisubmersible vessel, the configuration must be evaluated during pre-engineering to look into how the configuration of the water cooling and auxiliary is at present connected. For the autonomous control, the thruster control will be upgraded with more functionality to be able to run a restart after blackout without a restart procedure from automation.

### Everything must work together

Blackout recovery has a time frame of 45 seconds from complete blackout to being ready for DP. To meet this requirement, it is necessary to look not only at the power system, but also at the diesel generators, automation and the thrusters. Everything has to work together. For the power plant to be ready for DP, it takes about 10 seconds from when the diesel engines are ready, if the abovementioned upgrades are implemented.

DNV GL requires new tests, studies and reports to approve the closed bus DP3 operation. These are a live short-circuit test on board the vessel, an FMEA report on the power plant and a dynamic stability study. The FMEA report must be made by a third party and must be done on the complete power plant delivered from ABB. If any remarks come out of this report, ABB will follow up and take necessary action.

### Conclusion

The fleet of deep-water drilling vessels, built in accordance with previous classification rules, may be upgraded with solutions to meet the requirements of the newer and more stringent class notations. The efforts needed to upgrade the systems must be carefully analyzed and discussed with class societies to evaluate the content and scope of an upgrade. For some installations it might not be feasible. However, a range of technical solutions are available that can provide additional features for safety and availability regardless of full compliance or not with the newer notations.

### Øystein Hæhre

Global retrofit manager, ABB Marine, Norway  
oystein.hahre@no.abb.com

# Cross reference

2D strip theory	135-145
3D diffraction theory	135-145
800xA Industrial Extended Automation System	121-129
Adapting technology	6-9
ADO (Azipod dynamic optimizer)	121-129
Advisory systems	52-54, 78-79
AGVs (automated guided vehicles)	130-134
Allowable wave height	135-145
Alternative fuels	17-18
Anchor handlers	80-86
Arctic operations	32-39, 78-79, 87-92
Arctic sea routes	32-39
Artificial neural networks	99-109
ASC (automatic stacking cranes)	130-134
Asset and performance monitoring	121-129
Asset prices	40-43
Automated container terminals	130-134
Automated cranes	130-134
Automated gate systems	49-51, 130-134
Automated stack profiling	46-48
Automation	17-18, 46-51, 78-79, 110-134
Azimuth thrusters	32-39, 80-92, 121-129
Azipod®	32-39, 78-92, 121-129
Balanced efficiency	146-149
Ballast leg	146-149
Battery technology	17-18, 93-109
Bond market	60-62
Branding	24-26
Break power (PB)	146-149
Business case	14-16, 46-48, 68-69
Business schools	22-23
Capital expenditure (capex)	130-134
Cargo capacity	146-149
Cargo handling equipment	46-48
Cargo owners	10-11
CFD (computer fluid dynamics)	146-149
Charterers	10-11, 146-149
Chartering contracts	146-149
Class rules	110-120, 156-159
Classification	12-13, 19-21
Classification societies	12-13, 19-21
Cloud-based services	70-73
Collaboration	10-11, 19-21, 44-45, 49-51, 60-62, 68-68
Commissioning	44-45

Communication	24-26, 44-45, 60-63
Competition	24-26, 49-51
Compliance	19-21
Condition-based maintenance	67-67
Conflict in projects	44-45
Consultative process	68-69
Container industry	49-51
Container processing	78-79
Container terminals	46-51, 70-73, 130-134
Containerization	70-73
Continuous validation	19-21
Contractual agreement	14-16, 49-51, 60-62
Control modes	121-129
Control room	130-134
Cost of inventory	14-16
Cost-saving	110-120
Create value	68-69
Crew managers	64-66
Cruise ships	80-86
Customer needs	24-26
DC power distribution system	17-18, 93-98
Decision-making	22-26, 56-59, 63-67
Decision-making	121-129
Deep-water drilling vessels	156-159
Design assumptions	14-16
Design draft	146-149
Design life of the ship	14-16
Design optimization	99-109
Design point	14-16, 146-149
Design sea states	135-145
Design speed	146-149
Developing countries	49-51
DGMS (diesel generator monitoring system)	27-29, 156-159
Diagnostic solutions	150-155
diesel electric propulsion	19-21
Dispute resolution	60-62
Diversification	40-43
Documentation	44-45
Double Acting (DA) vessels	87-92
DP3 closed bus	156-159
Draft	121-129
Drilling	30-31
Drillships	27-29, 156-159
Dual-fuel engines	150-155

Dynamic simulations	156-159
Early adopters	19-21
Economic profit	4-5
Economically obsolete	24-26
Economics	6-9, 24-26
Ecoships	24-26
Efficiency	70-73
Electric distribution systems	78-79
Electric propulsion	32-39, 87-98, 150-155
Electric tugboats	99-109
Electrical engineering	19-21
Electrification	46-48, 99-109
Emergency conditions	19-21, 67-67
Emerging technologies	14-16, 19-21
EMMA™	121-129
Energy industry	30-31, 40-43
Energy sources	17-18
Energy storage	93-98, 121-129
Entrepreneurship	52-54
Environmental impact	10-11, 19-21, 40-43, 64-66, 93-98
Environmental incident	32-39
Equipment packages	44-45
Equipment manufacturer	24-26
Equipment packages	44-45
Ergonomic analysis	130-134
Exhaust cleaning	17-18
Expert systems	67-67
Export credit	74-75
Ferries	80-86
Financing	6-9, 40-43, 46-51, 60-63, 68-69, 74-75
FLNG	55-55
Floating position	121-129
FMEA analysis	156-159
Forecasting	52-54
Forecasting software solutions	52-54
Forward-thinking management	6-9
Freight rates	146-149
FSO (floating storage and offloading unit)	87-92
Fuel cost	10-11, 14-18, 40-43, 93-98
Fuel efficiency	17-18, 24-26, 67, 78-79, 146-149
Fuel measurement test	93-98
Fuzzy network	99-109
Gazprom	32-39
Gearless propulsor	80-86
Geopolitics	40-43
Global consumption of natural gas	150-155
Global network	64-66
Globalization	30-31
Heavy lift vessels	52-54, 56-59, 135-145
Hybrid Electric Vessels	99-109
Hydrodynamics	52-54, 121-129, 135-145
Ice management	87-92
Icebreakers	32-39, 87-92
IEC 61850	150-155
Independent shipowners	10-11

Industrial shipping	10-11, 22-23
Industry cycles	22-23
Information flow	78-79
Information technology	6-9
Innovation	6-9, 17-26, 32-39, 52-54, 74-75
Integrated supply chain	10-11
Integration	19-21, 130-134
Intelligent maneuvering	121-129
Intermodal and railroad operations	46-48, 68-69
Inventory time	14-16
Investments	40-43, 60-66, 74-75
IT project	130-134
Jack-up rigs	27-29
Keys to profitability	4-5
KPIs (key performance indicators)	64-66, 68-69
Laden leg	146-149
Land utilization	130-134
Legislation	40-43, 60-63
Life-cycle V model	19-21
Lifecycle benefits	74-75
Lifetime extension of onboard systems	78-79
Linear thinking	22-23
Liquid cargo	55-55
LNG (liquefied natural gas)	32-39, 150-155
LNG carriers	32-39, 150-155
LNGC	150-155
Load demand profile	99-109
Load prediction	99-109
Loading condition	135-145
Local content	40-43
LPG	40-43
Lump sum crew costs	64-66
Maersk	60-62
Maintenance cycles	121-129
Making a profit	27-31
Market cycles	22-26, 40-43, 64-66
Methanol	17-18
Minimizing downtime	27-29
Model system	19-21
Monitoring	52-54
Motion analyses	135-145
MPC (Model Predictive Control)	121-129
Multiple energy sources	17-18
Multipurpose ship	146-149
Natural gas	17-18, 150-155
Naval architects	146-149
Negotiation	49-51, 60-62
New technologies	6-9
New technologies	14-16, 19-21, 27-21, 27-21, 27-31
Newbuilding	27-29, 44-45, 60-62
Nonlinear regression models	121-129
OCR (optical character recognition)	49-51, 70-73, 130-134
OCTOPUS	52-59, 135-145
Off-hire	78-79
Offshore drilling	27-29

Offshore projects	60-62	Recruiting agents	64-66	Shipping market	40-43	Upgrade solutions	78-79, 156-159
Offshore supply vessels	80-86	Redundancies	27-29	Shipyards	19-21	Value proposition	68-69
Onboard DC Grid	78-79, 93-109	Regasification	150-155	Shore-powered ships	17-18	Variable frequency drives	93-98
One-to-one communication	24-26	Regulations	19-21, 40-43	Sloshing	55-55	Variable speed	24-26
Onshore support center	150-155	Regulatory framework	40-43	Social impact	40-43	Vertical integration	121-129
Operating expenditure (opex)	14-18, 46-48, 130-134	Regulatory requirements	70-73	SOG (speed over ground)	121-129	Vessel design	6-9
Operational characteristics	99-109	Relationships	44-45	Solar energy	17-18	Vessel information and control systems	52-54
Operational efficiency	12-13, 17-18, 46-54, 63-66, 130-134, 146-149	Reliability of vessels	64-66	Spinning reserve	121-129	Vessel lifetime	78-79
Operational modes	121-129	Remote control	130-134	Spot market	10-11	Vessel manager	64-66
Opportunity cost	4-5, 68-69	Remote diagnostic and monitoring	17-18, 67, 121-134, 150-155	Squatting	121-129	Vessel performance	14-16
Optimal speed	14-16	Research analysts	40-43	Stabilizer usage	121-129	Vessel stability analysis	135-145
Optimization	14-16, 52-54, 146-149	Response amplitude operators	135-145	Stacking cranes	130-134	Viscous damping	135-145
Optimization of power management	99-109	Response statistics	135-145	Standardization of interfaces	70-73	Vision	6-9
Optimization systems	52-54	return on investment	40-43	Standards	19-21	Volatility	40-43
Optimize performance	14-16, 78-79	Return over the lifetime of the asset	27-29	Stock exchange	40-43	Voyage costs	14-16
Optimum range	14-16	Risk assessment	10-13, 19-21, 24-31, 60-62	Stowage validation	70-73	Voyage simulations	135-145
Optimum voyage	135-145	Risk matrix	60-62	Strategic decision-making	6-9, 10-11	WHRS (waste heat recovery systems)	121-129
Organizational structure	22-23	Risk taken by banks	60-62	Strategy	22-23	Working environment	130-134
Over-supply	40-43	Risk-based approach	19-21	STS (ship-to-shore cranes)	49-51	Worldwide footprint	64-66
Overcapacity	40-43	Risks assessment	78-79	STW (speed through water)	121-129	Yachts	80-86
Overexposed	40-43	Risks in contracts	60-62	Subsidies	40-43		
Partnership manager/owners/operators	64-66	Risks on operational costs	64-66	Super capacitors	93-98		
PCS (Propulsion Control System)	121-129	ROI (return on investment)	27-29, 68-69	Support vector machine	99-109		
PDS (Position determination system)	49-51	Roll damping	135-145	System components	14-16		
PEMS (Power and Energy Management System)	93-98	Roll motions	135-145	System interaction	17-18		
Perceived value	4-5	Route optimization	56-59	Systems integration	44-45		
Performance-based compensation	64-66	RTG (rubber tyre gantry cranes)	49-51	Tailored solutions	17-18		
Place-and-time-independent working	52-54	Rudder usage	121-129	Talent	40-43		
Planning	27-29, 49-51	Safety	46-48	Tankers	55-55		
PMS	121-129	Safety culture	30-31	Tech-savvy decision makers	6-9		
Port equipment	130-134	SALM (single anchor leg mooring)	87-92	Technical flexibility	12-16, 19-21, 32-39		
Ports	46-51	Sea current	121-129	Technical knowledge	6-9		
Power breakdown monitoring system	121-129	Sea margin	146-149	Technology	12-13, 17-21, 63		
Power distribution	93-98	Sea state	121-129	Technology fragmentation	17-18		
Power estimation techniques	146-149	Seafarers	64-66	Technology integration	17-18		
Power generation, distribution and consumption	110-120	Seakeeping	52-54, 56-59, 135-145	Tenders	46-48		
Power management	99-109	Self-learning tools	67-67	Terminal equipment	130-134		
Power plant optimization	121-129	Semi-submersible drilling rigs	44-45, 80-86	Terminal network	46-48		
Power requirement	146-149	Semi-submersible vessel	156-159	Terminal operations	49-51, 68-69		
Predictability of scheduling	44-45	Senior management	6-9	Top-notch engineers	19-21		
prescriptive rules	19-21	Service providers	64-66	TOS (terminal operating system)	49-51, 70-73		
Private equity	40-43	SFOC (specific fuel oil consumption)	121-129	Total integration	110-120		
Profitability	40-45, 60-62, 64-66, 68-69, 78-79	Shale gas	40-43	Total lifecycle cost	78-79		
Project financing	60-62	Ship design	14-16, 146-149	Total logistics system	10-11		
Project Management	27-29, 44-45, 49-51	Ship management	64-67	Totally integrated systems	110-120		
Project team	44-45	Ship motion and RPM monitoring software	56-59	Training	17-18, 56-59		
Propelling effort	121-129	Ship motion monitoring	56-59	Transform shipping	10-11		
Propulsion	121-129	Ship specification	14-16	Transparency	64-66		
Propulsion control	121-129	Ship to gate	130-134	Transport capacity	146-149		
Propulsion efficiency	146-149	Shipbuilding contracts	146-149	Transport efficiency	10-11		
Propulsion power breakdown	121-129	Shipowners	10-11, 146-149	Transportation process	10-11		
Public markets	40-43	Shipping companies	24-26	Tugboats	99-109		
Range of operating points	146-149	Shipping industry	6-9	Turning points	22-23		
Rayleigh probability distribution	135-145	Shipping lines	46-48	Turnkey management	64-66		
				Understanding of shipping technology	6-9		



---

**Generations 2014**  
ISSN 1894-1079  
All rights reserved

*Generations* is published in Oslo, Norway by ABB Marine and Cranes, a business unit of ABB.

Executive editor: Eero Lehtovaara

The opinions expressed in this publication are those of the authors or persons interviewed and do not necessarily reflect the views of the editors or ABB Marine and Cranes or ABB.

This publication is not a retail product.

We at ABB are excited to hear your thoughts on *Generations*. Please share with us your comments or suggestions for further articles.

**Contact:** Ulrike Haugen, Group Assistant Vice President Communications at ABB, Marine and Cranes, [ulrike.haugen@no.abb.com](mailto:ulrike.haugen@no.abb.com)

---

#### **Editorial board**

Eero Lehtovaara  
Heikki Soljama  
Alf Kåre Ådnanes  
Rami-Johan Jokela  
Anders Røed  
Jyri Jusslin  
Juha Koskela  
Fred Hoonard  
Jorulf Nergard  
Jan-Fredrik Hansen

---

#### **Members of Marketing and Communications department involved**

Julia-Wei Cai  
Rafael Cola  
Ulrike Haugen

---

#### **Managing editors**

SAY PR & Communications – [www.say.biz](http://www.say.biz)  
Helen Karlsen  
Johs Ensby  
Daniel Barradas (design)

---

#### **Writers**

Helen Karlsen  
Johs Ensby  
David Hopkins  
Jennifer Varino  
Kevin Reader

---

#### **Photos and illustrations**

See article bylines  
Uncredited photos: ABB image bank or Shutterstock

---

---

#### **Business Insight – Contributors and interviewees**

Tim Ellis, Amarcon  
Leon Adegeest, Amarcon  
Topi Vesteri, Finnvera  
Hallvard Aamlid, ABB  
Victor Muñoz, TC Buen  
Martin Stopford, Clarksons Research  
Peter Lorange, Lorange Institute of Business  
Tiemen Meester, APM Terminals  
Rob Hindley, Lloyd's Register  
Tim Kent, Lloyd's Register Marine  
John Bradshaw, Lloyd's Register Marine  
Bernard Twomey, Lloyd's Register Marine  
Mikko Niini, Aker Arctic  
Capt. Rudiger Bauer, SAL Heavy Lift  
Jason Montegut, Rowan Companies  
Andrea Zito, VShips  
Andreas Sohmen-Pao, BW Group  
Finn Bjørnstad, Wikborg Rein  
Allen Thomas, APS Technology  
Clara Holmgren, ABB Crane Systems  
Patrick Vloemans, ABB Port Solutions

---

#### **Technical Insight – Contributors**

##### **ABB**

Alf Kåre Ådnanes  
Leon Adegeest  
Øystein Hæhre  
Jan Fredrik Hansen  
Jaroslav Nowak  
Henrique Pestana  
Björn Henriksson  
Antti Matilainen  
Kalevi Tervo  
Juha Orivuori  
Olli Huttunen  
Jan Fredrik Hansen  
Kimmo Kokkila  
Jukka Varis  
Samuli Hanninen  
Torsten Heideman  
Olli Toivanen  
Johan Pensar

##### **Nanyang Technological University, Singapore**

Jaspreet Singh Dhupia  
Aaron Alexander Ayu

##### **Massachusetts Institute of Technology, USA**

Thanh Long Vu

---