

# SPAU 130 C

## Three-phase overvoltage and undervoltage relay

User's manual and Technical description

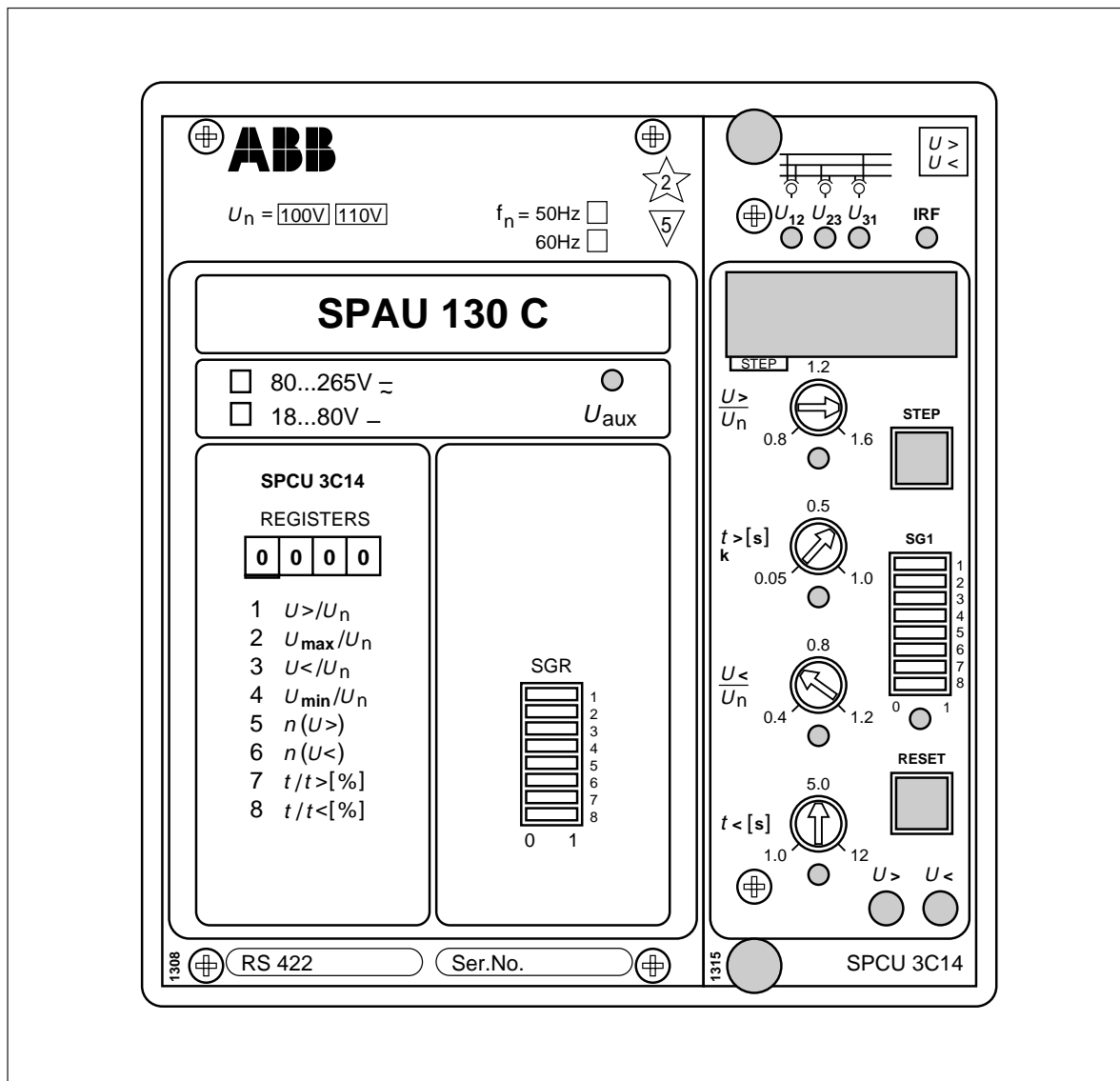

# SPAU 130 C

## Three-phase overvoltage and undervoltage relay

Data subject to change without notice

<b>Contents</b>	Features .....	2
	Application .....	3
	Function .....	3
	Connections .....	4
	Configuration of output relays.....	6
	Start and operation indicators.....	7
	Combined power supply and I/O module .....	7
	Technical data ( <i>modified 2002-04</i> ) .....	8
	Examples of applications.....	10
	Secondary injection testing .....	17
	Maintenance and repair .....	21
	Exchange and spare parts .....	21
	Ordering numbers .....	21
	Dimensions and mounting .....	22
	Order information .....	22

The complete manual for the combined overvoltage and undervoltage relay SPAU 130 C includes the following submanuals:

Three-phase overvoltage and undervoltage relay, general part	1MRS 750638-MUM EN
Overvoltage and undervoltage relay module SPCU 3C14	1MRS 750510-MUM EN
General characteristics of C-type relay modules	1MRS 750328-MUM EN

<b>Features</b>	Combined overvoltage and undervoltage protection relay	Numerical display of setting values, measured values, recorded fault values, indications etc.
	Three-phase definite time or inverse time overvoltage stage	Serial interface for bus connection module and optical-fibre substation bus
	Three-phase definite time undervoltage stage	Continuous self-supervision of relay hardware and software for enhanced system reliability and availability
	Control input for blocking of the function of the undervoltage stage by means of an external control signal	Auto-diagnostic fault indication to facilitate repair after detection of permanent internal relay fault
	Automatic blocking of the undervoltage stage on loss of energizing voltage	Powerful software support for parametrization and supervision of the relay
	Fully field-configurable output relay functions	
	Flexible matching of the relay to the intended protection application	The relay is a member of the SPACOM product family and PYRAMID <sup>®</sup> , ABB's coordinated protection and control concept

## Application

The three-phase voltage relay SPAU 130 C is intended to be used for overvoltage and undervoltage protection and supervision in distribution substations. The relay can also be used for overvoltage and undervoltage protection of generators, motors and transformers. Generally the relay measures the three phase-to-phase voltages of the system but it can also be programmed for single-phase measurement.

The overvoltage stage can be given definite time characteristic or inverse time characteristic. The undervoltage stage features definite time characteristic alone.

The operation of the undervoltage stage can be blocked by means of an external control signal.

The relay forms a whole including an overvoltage stage, an undervoltage stage as well as flexible trip and alarm functions.

## Description of function

The combined overvoltage and undervoltage relay SPAU 130 C is a secondary relay that is connected to the voltage transformers of the protected object. The relay generally measures the three phase-to-phase voltages of the system. On operating the relay trips the circuit breaker and/or provides alarm, in accordance with the selected functions and given configuration.

When one of the phase-to-phase voltage or several exceed the set start value  $U_{>}$  of the overvoltage stage, the overvoltage stage starts delivering a start signal SS1. When, at definite time mode of operation, the set operate time  $t_{>}$  or, at inverse time mode of operation, the calculated operate time  $t_{>}$ , has expired, the overvoltage stage operates delivering a trip signal TS1. In the same way the undervoltage stage starts delivering a start signal SS2 when the measured value goes below the start value  $U_{<}$  and when the set operate time  $t_{<}$  has expired, the undervoltage stage operates, delivering a trip signal TS2.

The overvoltage and undervoltage relay is generally used as a three-phase relay. But by means of a selector switch the relay can be configured as a single phase relay.

The overvoltage stage can be given definite time characteristic or inverse time characteristic. When inverse time characteristic is selected two sets of curves named A and B are available.

The undervoltage stage has definite time characteristic. Tripping of the undervoltage stage can be blocked by means of a control signal BS applied to the optically isolated external control input of the relay.

The overvoltage and undervoltage relay is provided with two output relays for tripping and three output relays for signalling purposes. One of the signalling relays is dedicated for the selfsupervision system of the relay.

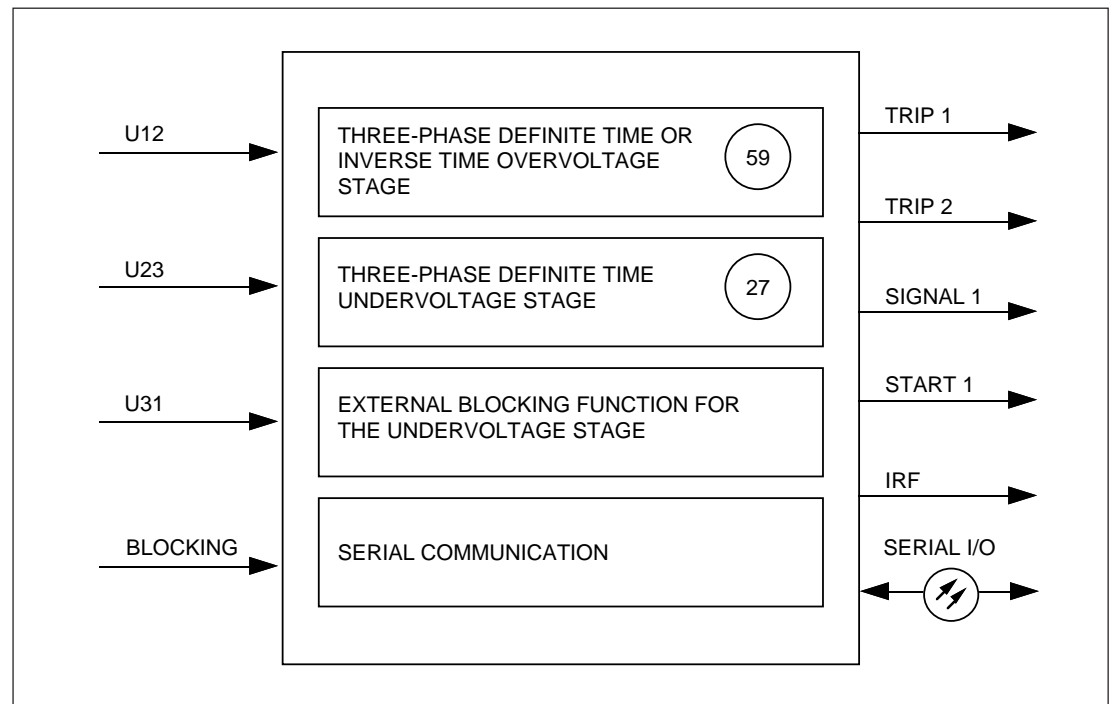

Fig. 1. Protection functions of the combined overvoltage and undervoltage relay SPAU 130 C. The encircled numbers refer to the ANSI (=American National Standards Institute) number of the concerned protection function.

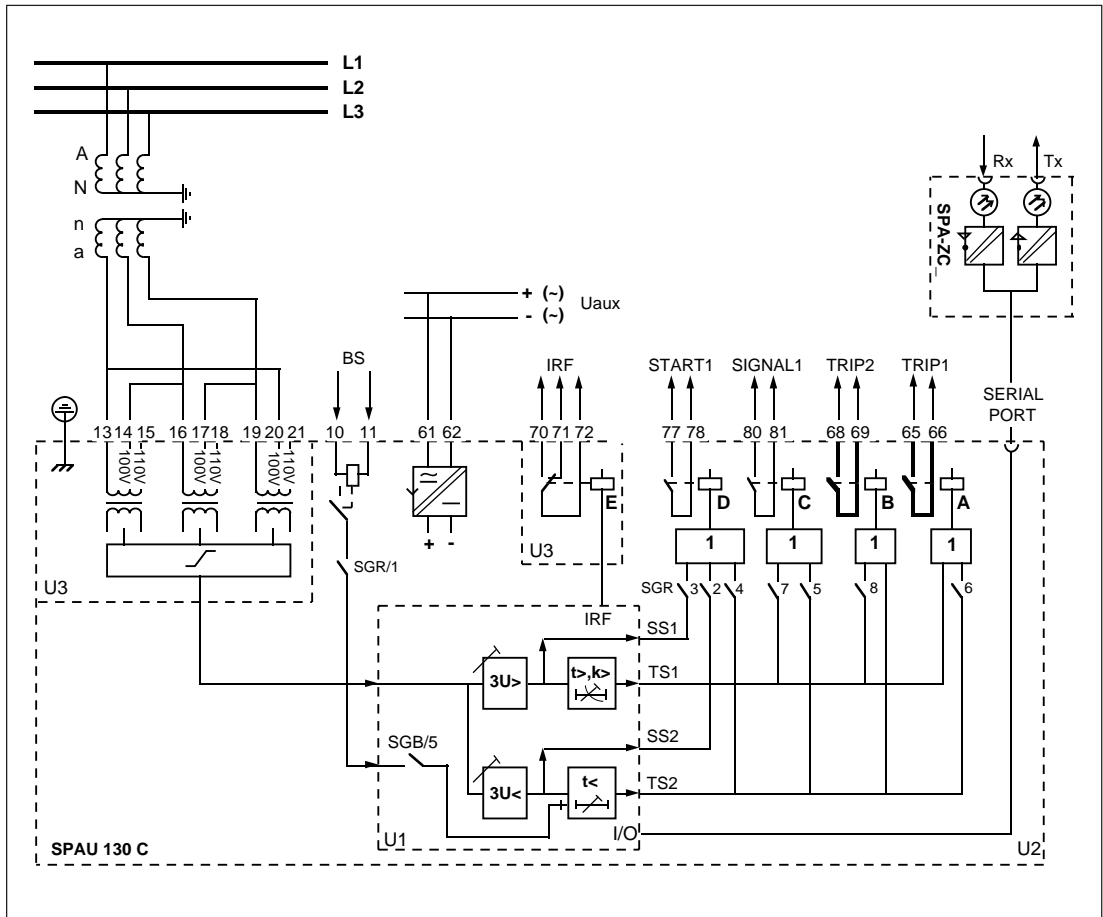

Fig. 2. Connection diagram for the combined overvoltage and undervoltage relay SPAU 130 C

$U_{aux}$	Auxiliary voltage
A,B,C,D,E	Output relays
IRF	Self-supervision signal
SS_	Start signal
TS_	Trip signal
SGR	Switchgroup for configuring trip and alarm signals
SGB/5	Switch for blocking the undervoltage stage
TRIP_	Trip output
SIGNAL1	Signal on relay operation
START1	Start signal or signal on relay operation
U1	Combined overvoltage and undervoltage relay module SPCU 3C14
U2	Power supply and I/O module SPTU 240S1 or SPTU 48S1
U3	I/O module SPTE 3E15
SERIAL PORT	Serial communication port
SPA-ZC_	Bus connection module
Rx/Tx	Optical-fibre receiver (Rx) and transmitter (Tx) of the bus connection module

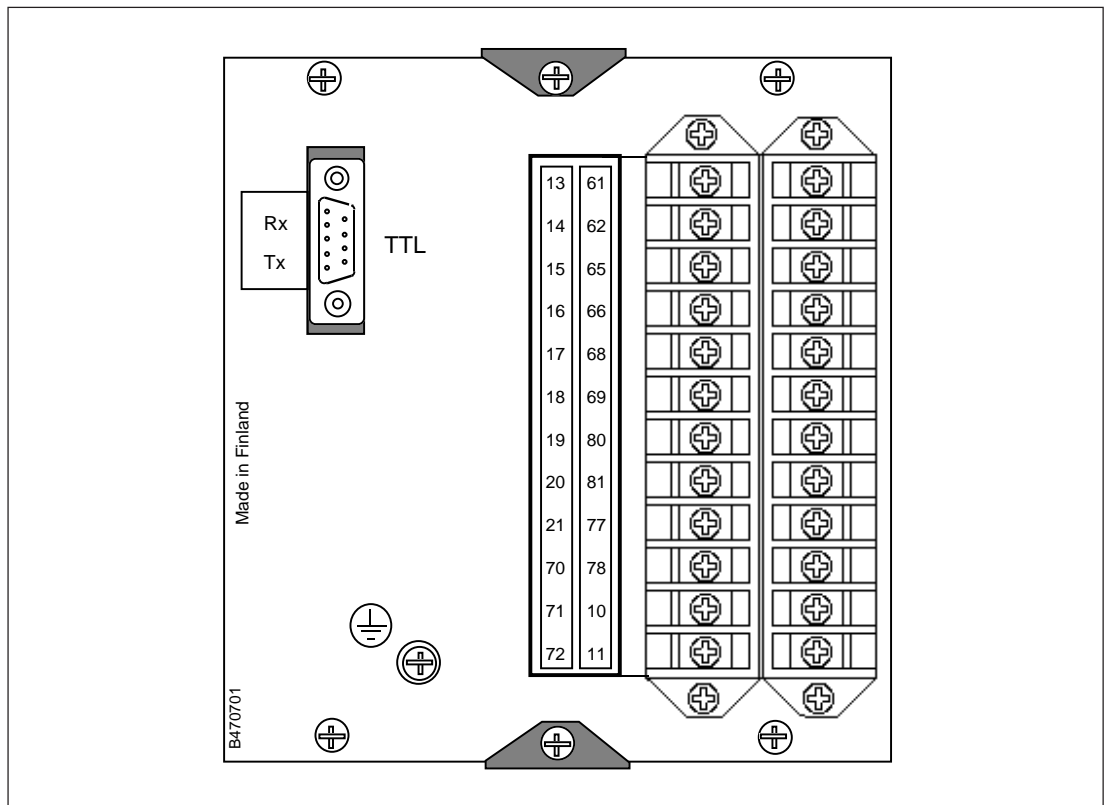



Fig.3. Rear view of the overvoltage and undervoltage relay SPAU 130 C

#### Specification of input and output terminals

Contacts	Function
13-14	Phase-to-phase voltage $U_{12}$ (100 V)
13-15	Phase-to-phase voltage $U_{12}$ (110 V)
16-17	Phase-to-phase voltage $U_{23}$ (100 V)
16-18	Phase-to-phase voltage $U_{23}$ (110 V)
19-20	Phase-to-phase voltage $U_{31}$ (100 V)
19-21	Phase-to-phase voltage $U_{31}$ (110 V)
10-11	External blocking signal input
61-62	Auxiliary power supply. When DC voltage is used the positive pole is connected to terminal 61.
65-66	Trip output 1 for stages $U_{>}$ and $U_{<}$ (TRIP 1)
68-69	Trip output 2 for stages $U_{>}$ and $U_{<}$ (TRIP 2)
80-81	Signal on tripping of stages $U_{>}$ and $U_{<}$ (SIGNAL 1)
77-78	Signal on tripping of stage $U_{<}$ , starting of stages $U_{>}$ and $U_{<}$ (START 1)
70-71-72	Self-supervision (IRF) alarm output. Under normal conditions the contact interval 70-72 is closed. When the auxiliary voltage disappears or an internal fault is detected, the contact interval 71-72 closes.
	Protective earth terminal

The combined overvoltage and undervoltage relay SPAU 130 C is connected to the optical fibre communication bus by means of the bus connection module SPA-ZC 17 or SPA-ZC 21. The bus connection module is connected to the D-type connector (SERIAL PORT) on the rear

panel of the relay. The opto-connectors of the optical fibres are plugged into the counter connectors Rx and Tx of the bus connection module. The selector switches of the bus connection module, by means of which the communication mode is selected, are to be set in position "SPA".

## Configuration of output relays

The trip signals of the U> stage is firmly wired to output relay A and the trip signal of the U< stage to output relay B. In addition, the follow-

ing functions can be selected with the switches of the SGR switchgroup on the front panel of the relay:

Switch	Function	Factory default	User's settings
SGR/1	Routes the external blocking signal to stage U<	1	
SGR/2	Routes the start signal of the U< stage to output relay D	1	
SGR/3	Routes the start signal of the U> stage to output relay D	1	
SGR/4	Routes the trip signal of the U< stage to output relay D	1	
SGR/5	Routes the trip signal of the U< stage to output relay C	1	
SGR/6	Routes the trip signal of the U< stage to output relay A	1	
SGR/7	Routes the trip signals of the U> stage to output relay C	1	
SGR/8	Routes the trip signals of the U> stage to output relay B	1	

Circuit breakers can be controlled directly with output relay A and B. This enables two circuit breakers to be controlled at the same time or

separate trip output relays can be configured for the overvoltage protection and the undervoltage protection.

## Start and operation indicators

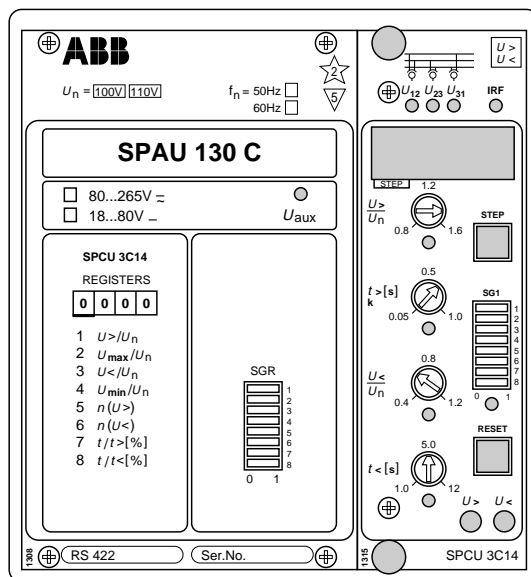

1. The relay module is provided with two operation indicator located in the right bottom corner of the front plate of the relay module. One indicates operation of the overvoltage stage and the other operation of the undervoltage stage. Yellow light indicates that the concerned stage has started and red light that the stage has operated (tripped).

With the SG2 software switchgroup the start and trip indicators can be given a latching function, which means that the LEDs remain lit, although the signal that caused operation returns to normal. The indicators are reset with the RESET push-button. An unreset indicator does not affect the operation of the relay.

2. The yellow LED indicators ( $U_{12}$ ,  $U_{23}$  and  $U_{31}$ ) on the upper black part of the front plate indicate, when lit, that the corresponding voltage value is currently being displayed.
3. The red IRF indicator of the self-supervision system indicates, when lit, that a permanent internal relay fault has been detected. The fault code appearing on the display once a fault has been detected should be recorded and notified when service is ordered.
4. The green  $U_{aux}$  LED on the front panel is lit when the power supply module operates properly.
5. The LED indicator below a particular setting knob indicates, when lit, that the setting value of the knob is currently being displayed.
6. The LED of the SG1 switchgroup indicates, when lit, that the checksum of the switchgroup is currently being displayed.

The start and operation indicators, the function of the SG2 software switchgroup and the functions of the LED indicators during setting are described more detailed in the user's manual "Combined overvoltage and undervoltage relay module SPCU 3C14".

## Combined power supply and I/O module

The combined power supply and I/O module (U2) is located behind the system front panel of the protection relay and can be withdrawn after removal of the system front panel. The power supply and I/O module incorporates a power unit, four output relays, the control circuits of the output relays and the electronic circuitry of the external control input.

The power unit is transformer connected, that is, the primary side and the secondary circuits are galvanically isolated. The primary side is protected by a slow 1 A fuse F1, placed on the PC board of the module. When the power source operates properly, the green  $U_{aux}$  LED on the front panel is lit.

The power supply and I/O module is available in two versions which have different input voltage ranges:

- type SPTU 240S1      $U_{aux} = 80...265 \text{ V ac/dc}$
- type SPTU 48S1      $U_{aux} = 18...80 \text{ V dc}$

The voltage range of the power supply and I/O module inserted in the relay is marked on the system front panel of the relay.

**Technical data**  
(modified 2002-04)

**Energizing inputs**

Terminals  
Rated voltage  $U_n$   
Continuous voltage withstand  
Power consumption at  $U_n$   
Rated frequency  $f_n$  acc. to order

**100 V**

13-14, 16-17, 19-20  
100 V  
 $2 \times U_n$   
<0.5 VA  
50 Hz or 60 Hz

**110 V**

13-15, 16-18, 19-21  
110 V  
 $2 \times U_n$

**Output contact ratings**

Trip contacts  
Terminals  
Rated voltage  
Carry continuously  
Make and carry for 0.5 s  
Make and carry for 3 s  
Breaking capacity for dc, when the manoeuvre  
circuit time constant  $L/R \leq 40$  ms,  
at the control voltages  
- 220 V dc  
- 110 V dc  
- 48 V dc

65-66, 68-69  
250 V ac/dc  
5 A  
30 A  
15 A

Signalling contacts  
Terminals  
Rated voltage  
Carry continuously  
Make and carry for 0.5 s  
Make and carry for 3 s  
Breaking capacity for dc, when the signalling  
circuit time constant  $L/R < 40$  ms,  
at the control voltages  
- 220 V dc  
- 110 V dc  
- 48 V dc

1 A  
3 A  
5 A  
  
70-71-72, 77-78, 80-81  
250 V ac/dc  
5 A  
10 A  
8 A  
  
0.15 A  
0.25 A  
1 A

**External control input (blocking)**

Terminals  
Control voltage  
  
Current consumption when active

10-11  
18...265 V dc or  
80...265 V ac  
2...20 mA

**Auxiliary supply voltage**

Power supply and I/O modules and voltage ranges:  
- type SPTU 240 S1  
- type SPTU 48 S1  
Power consumption under quiescent/operating  
conditions

80...265 V ac/dc  
18...80 V dc  
  
~4 W/~6 W



## Combined overvoltage and undervoltage relay module SPCU 3C14

- see "Technical data" in the manual for the module.

### Data communication

Transmission mode	Fibre optic serial bus
Data code	ASCII
Selectable data transfer rates	300, 1200, 2400, 4800 or 9600 Bd
Fibre optic bus connection module, powered from the host relay	
- for plastic fibre cables	SPA-ZC 21 BB
- for glass fibre cables	SPA-ZC 21 MM
Fibre optic bus connection module with a built-in power supply unit	
- for plastic fibre cables	SPA-ZC 17 BB
- for glass fibre cables	SPA-ZC 17 MM

### Insulation Tests \*)

Dielectric test IEC 60255-5	2 kV, 50 Hz, 1 min
Impulse voltage test IEC 60255-5	5 kV, 1.2/50 $\mu$ s, 0.5 J
Insulation resistance measurement IEC 60255-5	>100 M $\Omega$ , 500 Vdc

### Electromagnetic Compatibility Tests \*)

High-frequency (1 MHz) burst disturbance test IEC 60255-22-1	
- common mode	2.5 kV
- differential mode	1.0 kV
Electrostatic discharge test IEC 60255-22-2 and IEC 61000-4-2	
- contact discharge	6 kV
- air discharge	8 kV
Fast transient disturbance test IEC 60255-22-4 and IEC 61000-4-4	
- power supply	4 kV
- I/O ports	2 kV

### Environmental conditions

Specified ambient service temperature range	-10...+55°C
Long term damp heat withstand acc. to IEC 60068-2-3	<95%, +40°C, 56 d/a
Relative humidity acc. to IEC 60068-2-30	93...95%, +55°C, 6 cycles
Transport and storage temperature range	-40...+70°C
Degree of protection by enclosure for panel mounted relay	IP 54
Weight of relay including flush mounting case	3.0 kg

\*) The tests do not apply to the serial port, which is used exclusively for the bus connection module.

## Examples of application

### Example 1. Network overvoltage and undervoltage supervision

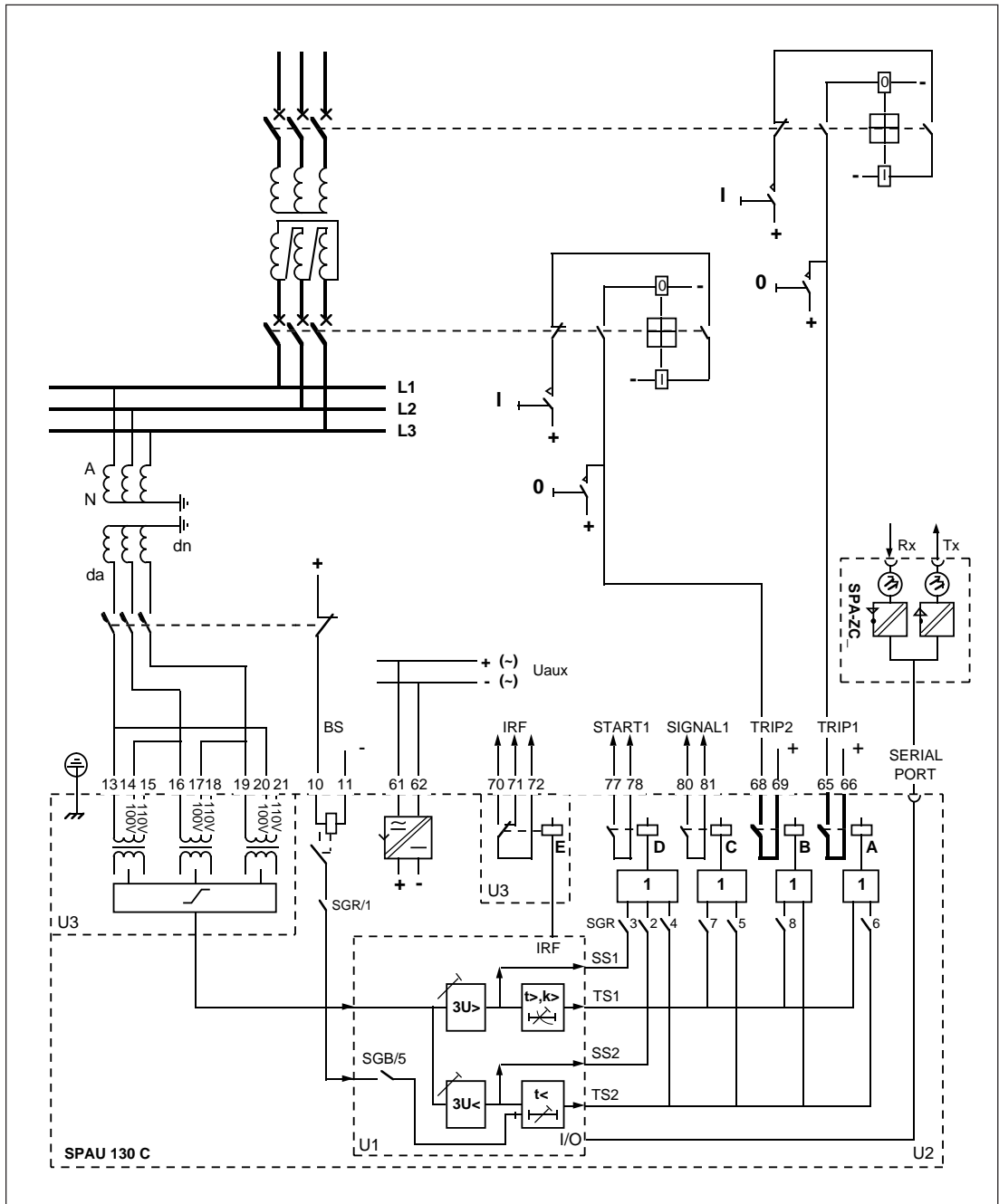

Fig. 4. Substation overvoltage and undervoltage protection with voltage relay SPAU 130 C. The selector switch positions are shown in the table on the following page.

The overvoltage and undervoltage relay module SPCU 3C14 measures the phase-to-phase voltages.

Many components of the power system are sensitive to overvoltage. Inverse time characteristic of the overvoltage relay is recommended as the liability to damage of the power system components often is a function of the duration of the overvoltage. At inverse time characteristic the relay provides an alarm signal at when the set start voltage has been exceeded. If the voltage exceeds 1.06 times the set start voltage the relay operates, the faster the greater the voltage is.

Thus the overvoltage stage provides an alarm signal when the overvoltage arises and trips the circuit breaker, if the voltage continues to rise.

When the characteristic curve A is selected the alarm level can be set low enough and still the voltage regulator is granted time enough to operate even during severe voltage fluctuations.

The undervoltage stage also trips the circuit breaker. An unwanted operation of the undervoltage stage during an autoreclose cycle can be inhibited with switch SG1/6. If switch SG1/6 = 1 the operation of the undervoltage stage is inhibited, when the voltage falls below  $20\% \times U_n$ .

An unwanted operation of the undervoltage stage when the miniature circuit breaker trips has been inhibited by routing a control voltage from the auxiliary contact of the MCB to the relay's control input 10-11. Switch SGB/5 on

the printed circuit board must be in position 1 as also switch SGR/1.

The selector switches of the voltage relay SPAU 130 C can be set as follows:

Switch	SG1/SPCU 3C14	SGB/SPCU 3C14	SGR
1	0 three-phase	0 not in use	1 control signal from miniature circuit breaker (MCB)
2	1 $U>$ start time = 30 s	0 not in use	1 start signal of stage $U<$ to output relay D
3	1 $U>$ inverse charact.	0 not in use	1 start signal of stage $U>$ to output relay D
4	0 } curve A	0 not in use	0 no trip signal of stage $U<$ to output relay D
5		1 blocking of stage $t<$	1 trip signal of stage $U<$ to output relay C
6	1 $U<$ stage blocked, if $U < 20\% \times U_n$	0 not in use	0 no trip signal of stage $U<$ to output relay A
7	1 $U<$ start time = 30 s	0 not in use	1 trip signal of stage $U>$ to output relay C
8	1 $t< = 10...120$ s	0 not in use	0 no trip signal of stage $U>$ to output relay B
$\Sigma$	230		

When the switches are set as above, the output relays of the voltage relay SPAU 130 C provide the following signals:

Contact	Function
65-66	Tripping of the circuit breaker on the high-voltage side of the transformer ( $U>$ )
68-69	Tripping of the circuit breaker on the low-voltage side of the transformer ( $U<$ )
80-81	Signal on tripping ( $U>$ and $U<$ )
77-78	Starting ( $U>$ and $U<$ )
70-71-72	Self-supervision

A prewarning of a voltage disturbance is obtained over the contact interval 77-78 and a signal on tripping of stage  $U>$  or  $U<$  is obtained over the contact interval 80-81. When the over-voltage stage or the undervoltage stage starts or operates the start indicator (yellow) or operation

indicator (red) of the concerned stage is lit. If the indicators are selfreset they are switched off when the measured voltage returns. If the indicators are latching they have to be reset manually with the reset push-button on the front panel or by remote control via the serial port.

Example 2.  
Motor undervoltage protection

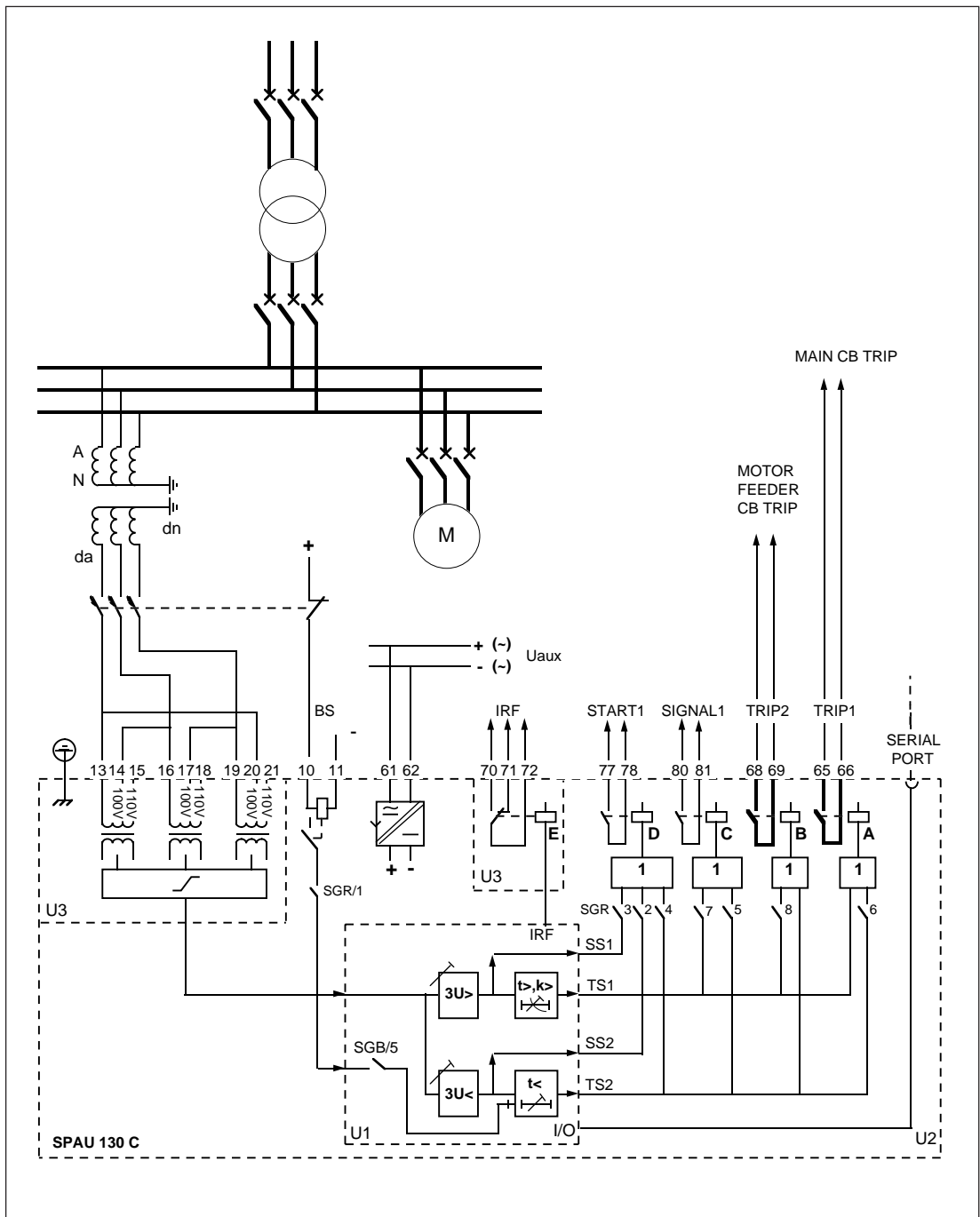

Fig. 5. Motor feeder undervoltage protection with relay SPAU 130 C. The selector switch positions are shown in the table on the following page.

The undervoltage stage of the relay trips the circuit breakers of the motor feeders connected to the busbar. In this way the motors are prevented from restarting at the same time on recovery of the voltage. The operate time setting of the undervoltage stage is to be longer than the dead time of the high-speed auto-reclose cycle of the transmission network. This prevents motors from tripping during short voltage interruptions.

An unwanted operation of the undervoltage stage when the miniature circuit breaker (MCB) trips has been inhibited by routing a control voltage from the auxiliary contact of the MCB to the control input 10-11 of the relay. Switch SGB/5 on the printed circuit board of the voltage relay module should be in position 1 as should also switch SGR/1.

The overvoltage stage protects the motors and transformers connected to the busbars. The overvoltage stage can be given inverse time characteristic. When the characteristic curve B is selected the start voltage can be set relatively high without rendering to long an operate time at severe overvoltage.

The overvoltage stage and the undervoltage stage are both used for tripping. The trip signal of the undervoltage stage is routed to the circuit breakers of the motor feeders. The overvoltage stage operates the main circuit breaker.

The selector switches of the voltage relay SPAU 130 C can be set as follows:

Switch	SG1/SPCU 3C14	SGB/SPCU 3C14	SGR
1	0 three-phase	0 not in use	1 control signal from miniature circuit breaker (MCB)
2	1 U> start time = 30 s	0 not in use	0 no start signal of stage U< to output relay D
3	1 U> inverse charact.	0 not in use	0 no start signal of stage U> to output relay D
4	1 } -curve B 0 }	0 not in use	1 trip signal of stage U< to output relay D
5		1 blocking of stage t<	0 no trip signal of stage U< to output relay C
6	0 U< stage blocked, if $U < 20\% \times U_n$	0 not in use	0 no trip signal of stage U< to output relay A
7	0 U< start time = 0.1 s	0 not in use	1 trip signal of stage U> to output relay C
8	0 t< = 10...12 s	0 not in use	0 no trip signal of stage U> to output relay B
$\Sigma$	14		

When the switches are set as above, the output relays of the voltage relay SPAU 130 C provide the following signals:

Contact	Function
65-66	Tripping of the main circuit breaker (U>)
68-69	Tripping of the circuit breakers of the motor feeders (U<)
80-81	Signal on tripping of the main circuit breaker (U>)
77-78	Signal on tripping of the circuit breakers of the motor feeders (U<)
70-71-72	Self-supervision signal

Example 3.  
Generator pole  
short-circuit  
protection

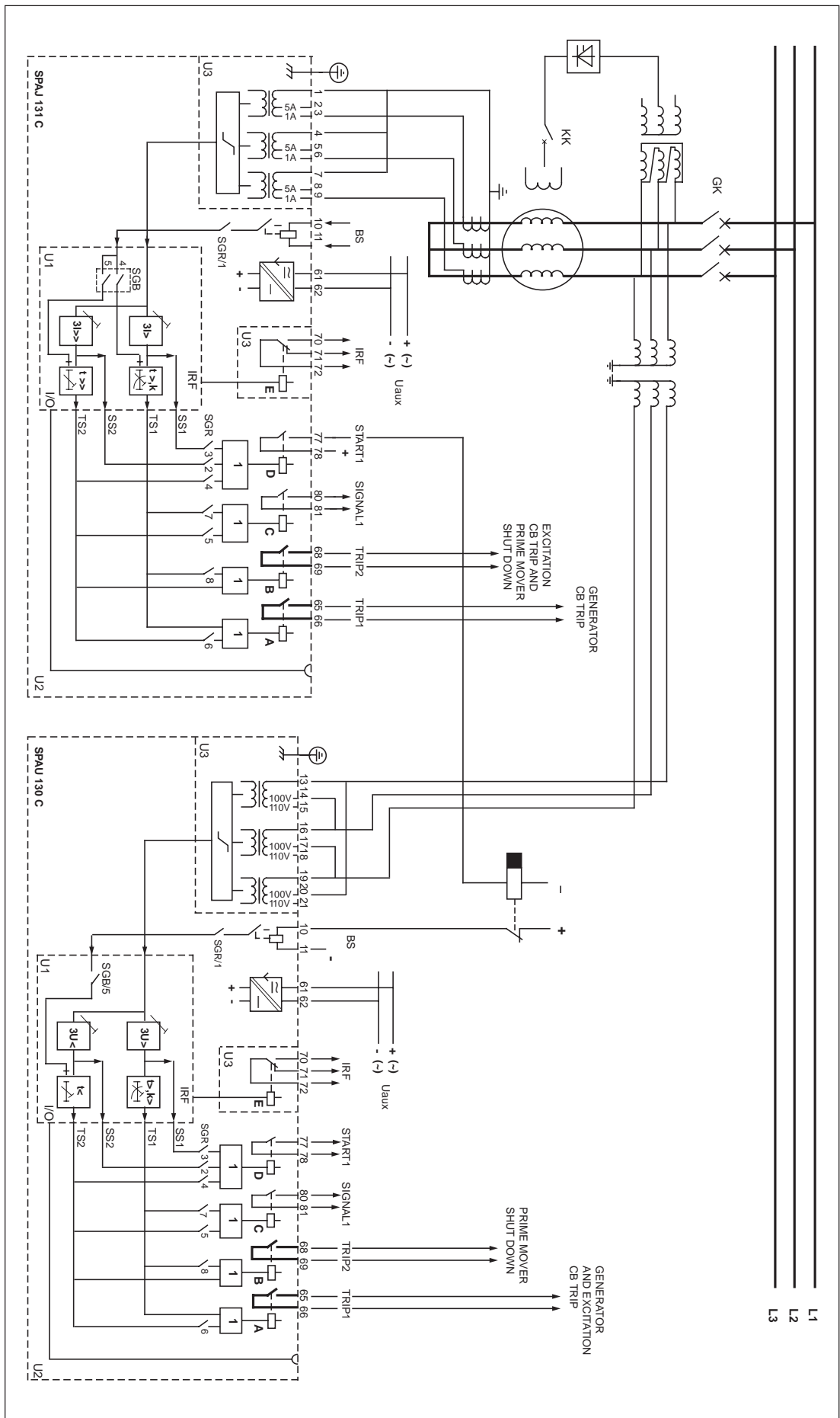

Fig. 6. Generator pole short-circuit protection with relays SPAU 130 C and SPAJ 131 C. The selector switch positions are shown in the table on the following page.

When a pole short-circuit occurs on a generator provided with a static excitation system the generator voltage and the excitation rapidly decrease so much, that the short-circuit current falls below the set start current of the overcurrent relay.

By capturing the start signal of the overcurrent relay with a drop-off delayed auxiliary relay, which controls the external blocking input of the undervoltage relay, the protection arrangement can be made to operate, even though the overcurrent relay resets without tripping. The undervoltage stage is normally blocked and it is deblocked by the starting signal of the low-set

stage of the overcurrent relay. The undervoltage stage trips the circuit breaker after the set operate time  $t_{<}$ .

When required, the undervoltage stage can be blocked when the miniature circuit breaker of the energizing voltage circuit operates.

The start signal of the undervoltage stage can be used for preventing the generator from being connected to the network during undervoltage or for alarming on undervoltage.

The selector switches of the voltage relay SPAU 130 C can be set as follows:

Switch	SG1/SPCU 3C14	SGB/SPCU 3C14	SGR
1	0 three-phase	0 not in use	1 blocking signal from the drop-off delayed relay
2	1 $U_{>}$ start time = 30 s	0 not in use	1 start signal of stage $U_{<}$ to output relay D
3	1 $U_{>}$ inverse charact.	0 not in use	0 no start signal of stage $U_{>}$ to output relay D
4	1 } 0 } curve B	0 not in use	0 no trip signal of stage $U_{<}$ to output relay D
5		1 blocking of stage $t_{<}$	1 trip signal of stage $U_{<}$ to output relay C
6	0 $U_{<}$ no block., when $U < 20\% \times U_n$	0 not in use	1 trip signal of stage $U_{<}$ to output relay A
7	0 $U_{<}$ start time = 0.1 s	0 not in use	1 trip signal of stage $U_{>}$ to output relay C
8	0 $t_{<} = 1 \dots 12$ s	0 not in use	0 no trip signal of stage $U_{>}$ to output relay B
$\Sigma$	14		

When the switches are set as above, the output relays of the voltage relay SPAU 130 C provide the following signals:

Switch	Function
65-66	Tripping of the generator circuit breaker and the excitation circuit breaker on pole short circuit (stages $U_{<}$ and $I_{>}$ ) or on overvoltage (stage $U_{>}$ )
68-69	Prime mover shut down on pole short circuit (stages $U_{<}$ and $I_{>}$ )
80-81	Signal on operation of the overvoltage stage or pole short circuit protection
77-78	Start signal of the undervoltage stage $U_{<}$
70-71-72	Self-supervision signal

The output contacts of the relay SPAJ 131 C can be given the following functions:

Switch	Function
65-66	Tri' of generator circuit breaker, stages $I_{>}$ and $I_{>>}$
68-69	Tripping of excitation circuit breaker and shut down, stage $I_{>>}$
80-81	Signal on operation of stage $I_{>}$ and $I_{>>}$
77-78	Start signal from stage $I_{>}$ to the drop-off delayed auxiliary relay
70-71-72	Self-supervision alarm signal

The registers of the overvoltage and undervoltage relay contain useful information about the behaviour of the power network during normal service and in a fault situation.

On starting of the overvoltage stage the maximum value of the measured voltages is recorded in register 1 as a multiple of the rated voltage. Any new starting of the overvoltage stage erases the old value from the register and a new value is recorded. On operation of the overvoltage stage the value gathering sequence is stopped and the highest measured value during the starting period is recorded.

Register 2 contains the maximum value of the voltages measured after a relay reset as a multiple of the rated voltage. The registered value is updated any time when the value of the measured voltage exceeds the registered voltage value. Register 2 must be erased by a command given via the serial bus or by pressing the STEP and RESET push-buttons simultaneously.

On starting of the undervoltage stage the minimum value of the measured voltages is recorded in register 3 as a multiple of the rated voltage. Any new starting of the undervoltage stage erases the old value from the register and a new value is recorded. On operation of the undervoltage stage the value gathering sequence is stopped and the lowest measured value during the starting period is recorded.

Register 4 contains the minimum value of the voltages measured after a relay reset as a multiple of the rated voltage. The registered value is updated any time when the value of the measured voltage falls below the registered voltage value. Register 4 must be erased by a command

given via the serial bus or by pressing the STEP and RESET push-buttons simultaneously.

The number of startings, register 5 and 6, provides information on the occurrence of overvoltage and undervoltage in the network. It must, however, be noted that when the start time setting is 0.1 s, for instance, starting motors can cause the undervoltage stage to start and the value of register 6 to be updated. In the same way the overvoltage stage may start on temporary overvoltages caused by, for instance, by a voltage regulator.

Registers 7 and 8 show the duration of the latest start situation of the stages, expressed in per cent of the set operate time or of the calculated operate time for the overvoltage stage. Any new start erases the old value and a new value is recorded. If the stage operates, the register value will be 100.

The values of register 7 and 8 provide information about the duration of the voltage variations and how close to operation the overvoltage and undervoltage stages have been. Further information is obtained about the function of the voltage regulator.

Register 2 and 4 provide information about the limits of fluctuation of the busbar voltage during normal service.

Registers 1 and 3 as well as 7 and 8 facilitate the post-fault analysis. These registers provide information about the voltage levels in a network disturbance situation and how close to operation the overvoltage and undervoltage stages have been.



## Secondary injection testing

Relay testing, both primary and secondary, should always be performed in accordance with national regulations and instructions.

The protection relay incorporates an IRF function that continuously monitors the internal state of the relay and produces an alarm signal on detection of a fault. According to the manufacturer's recommendations the relay should be submitted to secondary testing at five years' intervals. These tests should include the entire protection chain from the instrument transformers to the circuit breakers.

The secondary testing described in this manual is based on the relay's setting values during normal operation. If necessary, the secondary testing can be extended by testing the protection stages throughout their setting ranges.

As switch positions and setting values have to be altered during the test procedure the correct positions of switches and the setting values of the relay during normal operation conditions have to be recorded, for instance, on the reference card accompanying the relay.

For secondary testing the relay must be disconnected from the voltage transformer circuits and other secondary circuits by means of disconnectable terminal blocks or a test adapter fitted on the relay. A possible connection of the relay to the circuit breaker trip coil must be noted during the test.

When the auxiliary voltage is connected to the relay, a self-testing program is carried out automatically. The self-testing program includes the whole relay except for the matching transformers and the contacts of the output relays. The operational condition of the relay is tested using ordinary relay test equipment. The secondary injection test also includes the matching transformers, the output relays and the accuracy of the operate values.

When no relay test set is available the secondary injection test can be carried out with the following equipment:

- regulating transformer
- isolating transformer, e.g. 220 V/220 V
- voltmeter
- stop watch or counter for time measurement
- dc voltage source
- switches and indicator lamps
- supply and pilot wires
- calibrated multimeter

Note the relay's rated voltage when measuring wires are connected to the terminals of the relay, see chapter Technical data, passage Energizing inputs.

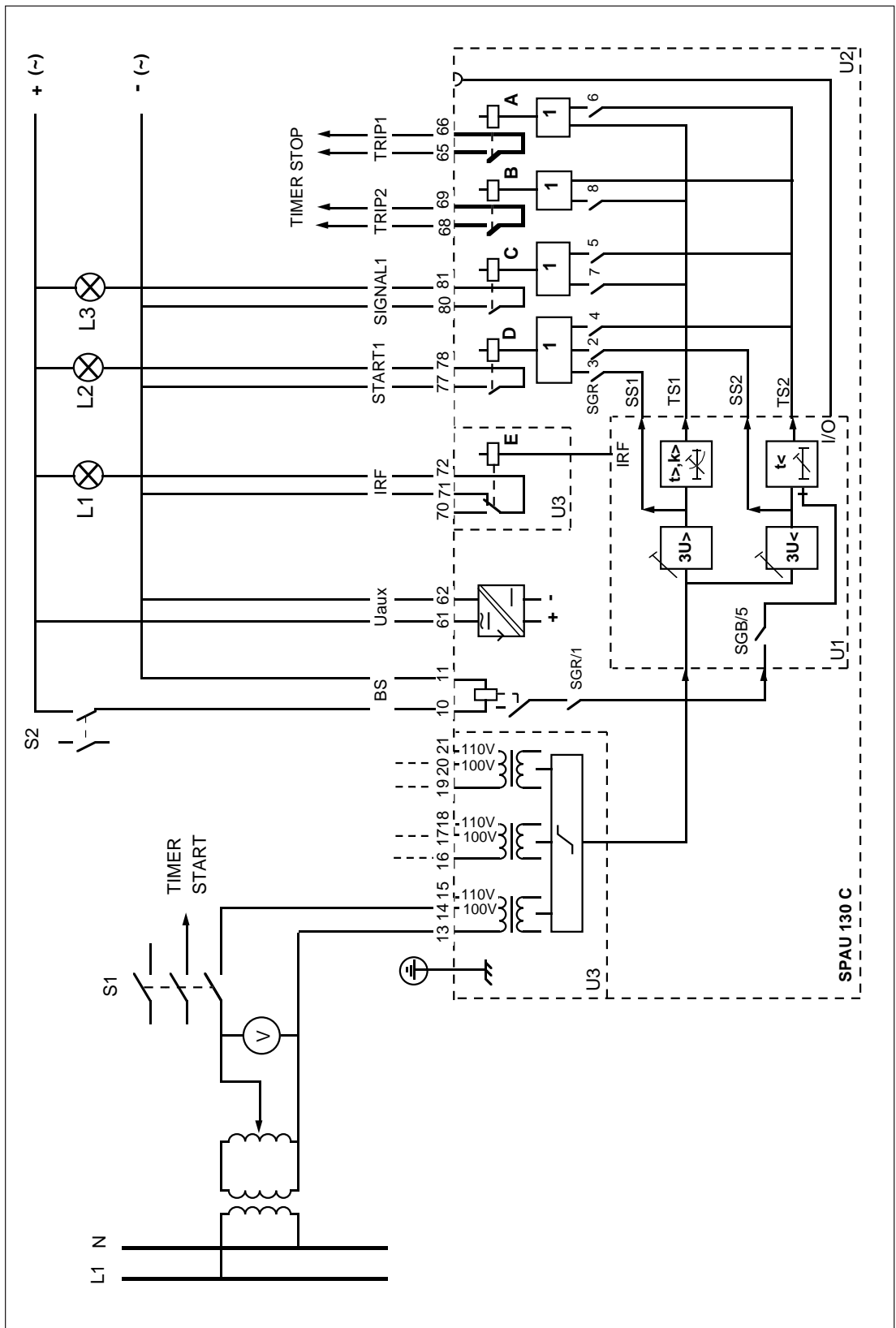

Fig. 7. Test circuit for the overvoltage and undervoltage relay SPAU 130 C.

When the test circuit has been completed and the selector switches properly set, the auxiliary voltage can be connected to the relay. The

function of the test circuit can be verified by means of a multimeter.

### Checking the matching transformers

The three matching transformers of the relay are checked one by one. Apply voltage to the relay and compare the voltage value read from the display of the relay with the voltage value shown by the voltmeter. The measurements can be performed at the rated voltage of the relay.

### Checking the overvoltage stage U>

Set the switches of the SGR switchgroup as follows before starting the test:

Switch	Position
1	1
2	0
3	1
4	0
5	0
6	0
7	1
8	0

The following relay functions are obtained:

Output relay (terminals)	Function
A (65-66)	Trip signal of stage U> (Trip signal of stage U<)
B (68-69)	
C (80-81)	
D (77-78)	Start signal of stage U>
E (70-71-72)	Self-supervision signal

### Checking the start function

Apply test voltage to terminals 13-14 or 13-15 depending on the used energizing input. Close switch S1 and increase the voltage slowly until the overvoltage stage starts and indicator L2 is lit. Read the start voltage value from the voltmeter.

Operate time  $t_{>}$

#### *Definite time characteristic*

If possible, set the test voltage at 2 x the set start voltage of the overvoltage stage. Note! The maximum voltage withstand of  $2 \times U_n$  must not be exceeded. The timer is started by switch S1, when it is closed and stopped by contact 65-66, when output relay A picks up.

The operation of output relay C is indicated with indicator L3, when it is lit.

When the relay starts the LED indicator U> in the lower right corner of the front panel is lit with yellow colour. When the overvoltage stage operates the LED indicator turns red.

#### *Inverse time characteristic*

When the relay has been set for inverse time characteristic, the test is performed by measuring the operate time at two voltage values, e.g.  $1.1 \times U_{>}$  and  $1.4 \times U_{>}$  and by comparing the operate times with the operate times obtained from the characteristic curves.

Checking the undervoltage stage  $U_{<}$

Set the switches of the SGR switchgroup as follows before starting the test:

Switch	Position
1	1
2	1
3	0
4	0
5	1
6	0
7	0
8	0

The following relay functions are obtained:

Output relay (terminals)	Function
A (65-66)	(Trip signal of stage $U_{>}$ )
B (68-69)	Trip signal of stage $U_{<}$
C (80-81)	Signal on operation of stage $U_{<}$
D (77-78)	Start signal of stage $U_{<}$
E (70-71-72)	Self-supervision signal

Further, switch SG1/1 is set in position 1, which makes the relay a single phase relay.

Checking the start function

Set the test voltage at a value slightly above the set start voltage  $U_{<}$  of the undervoltage stage. Close switch S1 and lower the voltage slowly until the undervoltage stage starts and indicator L2 is lit. Read the start voltage value from the voltmeter.

Operate time  $t_{<}$

*Definite time characteristic*

Set the test voltage at 0.5 times the set start voltage of the undervoltage stage. The timer is started by switch S1, when it is closed and stopped by contact 68-69, when output relay B picks up.

Note!

If the test voltage setting is below  $0,2 \times U_n$ , switch SG1/6 must be set in position 0.

Checking the blocking function

Set switch SGB/5 of the relay module in position 1 (ON) and switch SGR/1 in position 1.

Check the blocking function by applying a control voltage (voltage value within the same range as the auxiliary voltage) via switch S2 to the control input 10-11. Set the test voltage at 2 times the set start voltage of the undervoltage stage. Lower the voltage until the undervoltage stage starts and indicator L2 is lit but the undervoltage stage is not permitted to operate.

Checking the output relay of the self-supervision system (IRF)

The self-supervision system and the function of the IRF LED and the output relay E can be tested in the Trip test mode described in manual "General characteristics of C type relay modules". The operation of output relay E is indicated by L1.

## Maintenance and repair

When used under the conditions specified in chapter "Technical data", the relay requires practically no maintenance. The relay includes no parts or components that are sensitive to abnormal physical or electrical wear under normal operating conditions.

If the environmental conditions on site differ from those specified, as to temperature and humidity, or if the atmosphere around the relay contains chemically active gases or dust, the relay should be visually inspected during the relay secondary testing. The visual inspection should focus on:

- Signs of mechanical damage on relay case and terminals
- Dust accumulated inside the relay cover or case; remove carefully with compressed air or a soft brush
- Signs of corrosion on terminals, case or components inside the relay

If the relay fails in operation or if the operation values considerably differ from those stated in the relay specifications, the relay should be given a proper overhaul. Minor measures, such as exchange of a faulty module, can be taken by personnel from the customer's instrument workshop, but major measures involving the electronics are to be taken by the manufacturer. Please contact the manufacturer or his nearest representative for further information about checking, overhaul and calibration of the relay.

### Note!

The protection relays contain electronic circuits which are liable to serious damage due to electrostatic discharge. Before removing a module, ensure that you are at the same electrostatic potential as the equipment by touching the case.

### Note!

Static protection relays are measuring instruments and should be handled with care and protected against damp and mechanical stress, especially during transport and storage.

---

## Exchange and spare parts

Overvoltage and undervoltage relay module	SPCU 3C14
Combined power supply and I/O module	
- $U_{aux} = 80...265$ V ac/dc	SPTU 240S1
- $U_{aux} = 18...80$ V dc	SPTU 48S1
Case (including I/O module)	SPTK 3E15
I/O module	SPTE 3E15
Bus connection module	SPA-ZC 17_ or SPA-ZC 21_

---

## Ordering numbers

Combined overvoltage and undervoltage relay	
SPAU 130 C	RS 422 020 -AA, CA, DA, FA
Combined overvoltage and undervoltage relay including test adapter RTXP 18	
SPAU 130 C	RS 422 220 -AA, CA, DA, FA

The two last letters of the ordering number designate the rated frequency  $f_n$  and the  $U_{aux}$  voltage range of the relay as follows:

- AA:  $f_n = 50$  Hz and  $U_{aux} = 80...265$  V ac/dc
- CA:  $f_n = 50$  Hz and  $U_{aux} = 18...80$  V dc
- DA:  $f_n = 60$  Hz and  $U_{aux} = 80...265$  V ac/dc
- FA:  $f_n = 60$  Hz and  $U_{aux} = 18...80$  V dc

## Dimensions and mounting

The relay case is basically designed for flush-mounting. The mounting depth can be reduced with an optional raising frame: type SPA-ZX 111 reduces the depth behind the mounting panel by 40 mm, type SPA-ZX 112 reduces the

depth by 80 mm and type SPA-ZX 113 reduces the depth by 120 mm. The relay can also be mounted in a case for surface mounting, type designation SPA-ZX 115.

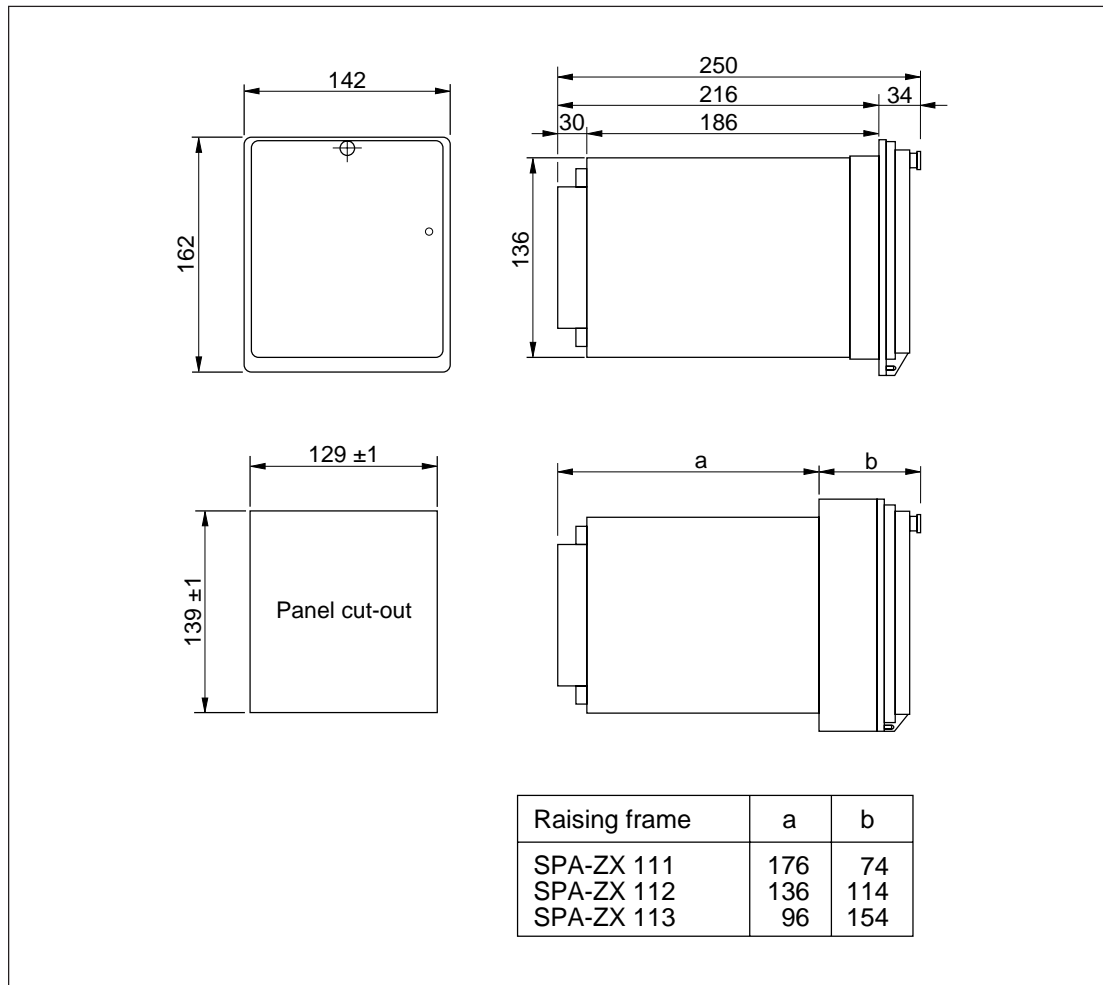

Fig. 8. Dimensions of the overvoltage and undervoltage relay SPAU 130 C

The relay case is made of profile aluminium and finished in beige.

A rubber gasket fitted on the mounting collar provides an IP54 degree of protection between relay case and mounting panel, when the relay is flush mounted.

The hinged cover of the relay case is made of clear, UV stabilized polycarbonate, and provided with a sealable finger screw. A gasket along

the edge of the cover provides an IP 54 degree of protection by enclosure between the relay case and the front cover.

All input and output wires are connected to the screw terminal blocks on the rear panel. Each terminal is dimensioned for one max. 6 mm<sup>2</sup> wire or two max. 2.5 mm<sup>2</sup> wires. The D-type connector connects to the serial communication bus via a bus connection module.

## Order information

- Quantity and type designation
- Order number
- Rated frequency
- Auxiliary voltage
- Accessories
- Special requirements

Example:

15 pcs voltage relay SPAU 130 C

RS 422 020-AA

$f_n = 50$  Hz

$U_{aux} = 110$  V dc

15 bus connection modules SPA-ZC 21 MM

2 fibre optic cables SPA-ZF MM 100

14 fibre optic cables SPA-ZF MM 5

–

# SPCU 3C14

## Combined overvoltage and undervoltage relay module

User's manual and Technical description

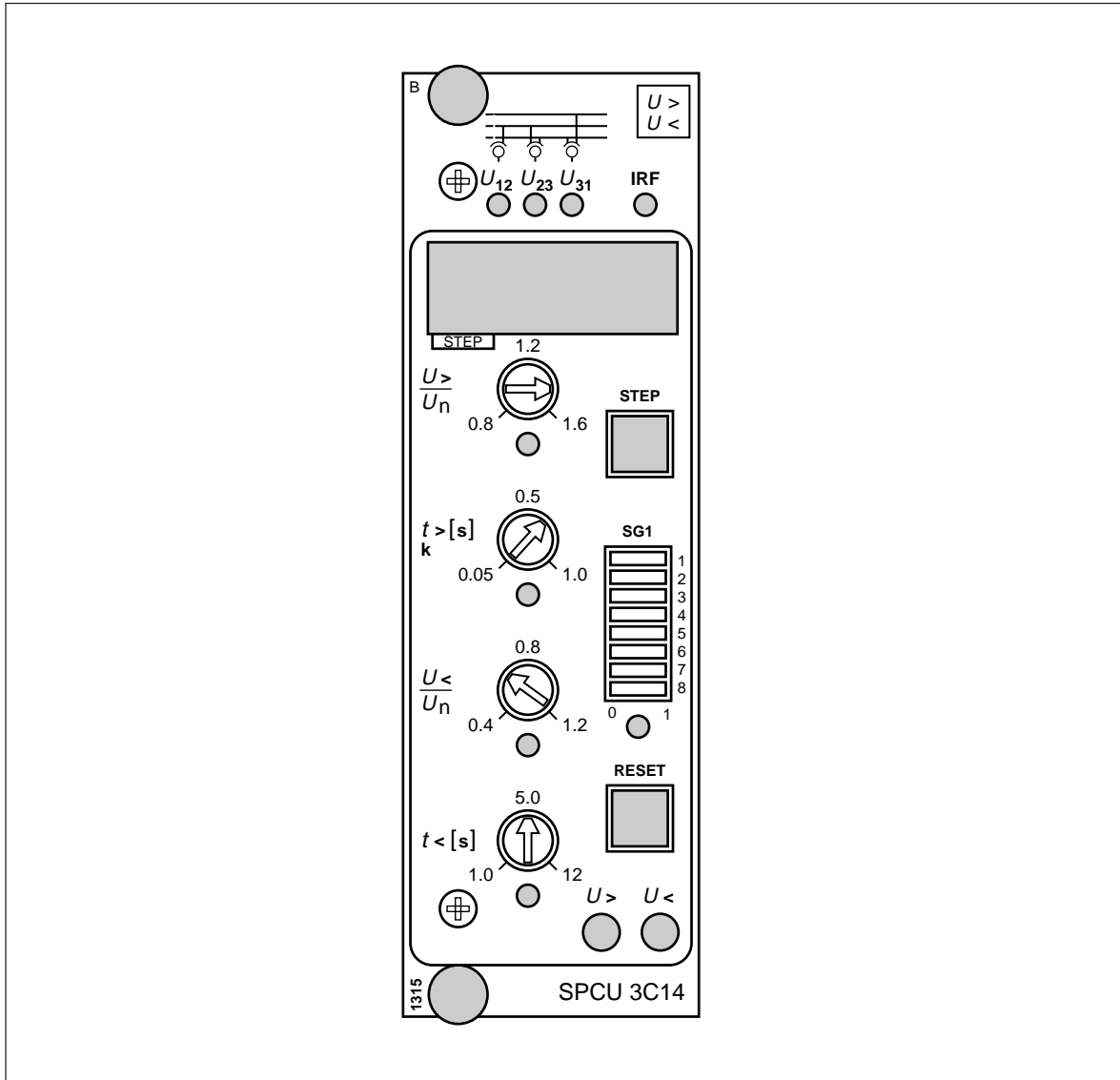

# SPCU 3C14

## Combined overvoltage and undervoltage relay module

Data subject to change without notice

<b>Contents</b>	Features .....	2
	Description of operation .....	3
	Block diagram .....	4
	Front panel .....	5
	Start and operation indicators .....	5
	Settings .....	6
	Selector switches ( <i>Modified 99-12</i> ) .....	6
	Measured data .....	8
	Recorded information .....	8
	Menu chart .....	10
	Voltage/time characteristic ( <i>Modified 99-10</i> ) .....	11
	Technical data .....	12
	Serial communication parameters .....	13
	Event codes .....	13
	Data to be transferred over the serial bus ( <i>Modified 99-12</i> ) .....	14
	Fault codes .....	17

<b>Features</b>	Three-phase voltage measuring relay module which also can be programmed for use in single-phase applications	Automatic blocking of the undervoltage stage on loss of energizing voltage
	Overvoltage stage with definite time or inverse definite minimum time characteristic	Digital display of measured values, set values and recorded fault values
	Two sets of voltage/time curves selectable at inverse time operation	Serial communication capability for extensive exchange of data with substation level equipment
	Undervoltage stage with definite time characteristic	Continuous self-supervision of hardware and software for enhanced reliability and availability
	External blocking of the undervoltage stage via built-in control input	Auto-diagnostic fault codes generated by the module on detection of a permanent internal fault



## Description of operation

The combined overvoltage and undervoltage module SPCU 3C14 is a three-phase relay module, which can be programmed for single-phase operation by means of switch SG1/1 on the front panel. The module contains an overvoltage stage and an undervoltage stage. The overvoltage stage can be given either definite time or inverse time characteristic, whereas the operation of the undervoltage stage is based on definite time characteristic only.

If one of the voltages measured by the module exceeds the set start value of the  $U_{>}$  stage, the module delivers a start signal SS1 after the set start time has expired. The start time of the  $U_{>}$  stage is selected by means of switch SG1/2, and two alternative values are available. After the preset operate time  $t_{>}$ , or at inverse time characteristic, after a time depending on the level of the overvoltage, the overvoltage stage operates delivering a trip signal TS1.

The operation characteristic of the  $U_{>}$  stage, i.e. definite time or inverse time characteristic, is selected with switch SG1/3. At definite time characteristic the setting range of the operating

time is programmed with switches SG1/4 and 5. At inverse time characteristic two different sets of voltage/time curves, called A and B, can be selected by means of switch SG1/4. At inverse time characteristic switch SG1/5 has no function.

If one of the voltages measured by the module falls below the set start value of the  $U_{<}$  stage, the module delivers a start signal SS2 after the set operate time has expired. The start time of the  $U_{<}$  stage is selected by means of switch SG1/7, and two alternative values are available.

After the preset operate time  $t_{<}$ , a trip signal TS2 is delivered by the undervoltage stage. The setting range of the operate time is selected with switch SG1/8.

To avoid unwanted operations, for instance during an auto-reclose sequence, starting and tripping of the undervoltage stage can be blocked by turning switch SG1/6 into the position 1. The blocking function is activated if the measured signal falls to a value below  $0.2 \times U_n$ . This function is illustrated in Fig. 1.

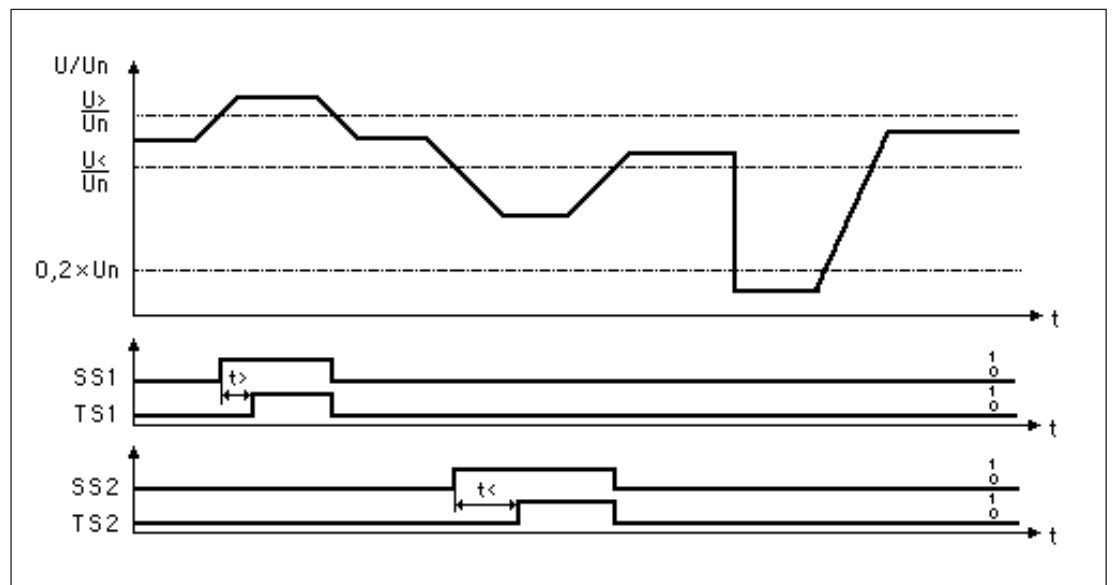

Fig. 1. Operation of the combined overvoltage and undervoltage relay module SPCU 3C14 when the function of the undervoltage stage is internally blocked (SG1/6 = 1).

Tripping (TS2) of the  $U_{<}$  stage alone, may be blocked by applying a blocking signal BTS2 on the stage. The blockings are programmed individually for the various relay assemblies by means of the switchgroup SGB on the relay module.

Programming instructions for the SGB switchgroup are given in the user's manual of the concerned protection relay unit. Also see the signal diagram of the concerned protection relay unit.

## Block diagram

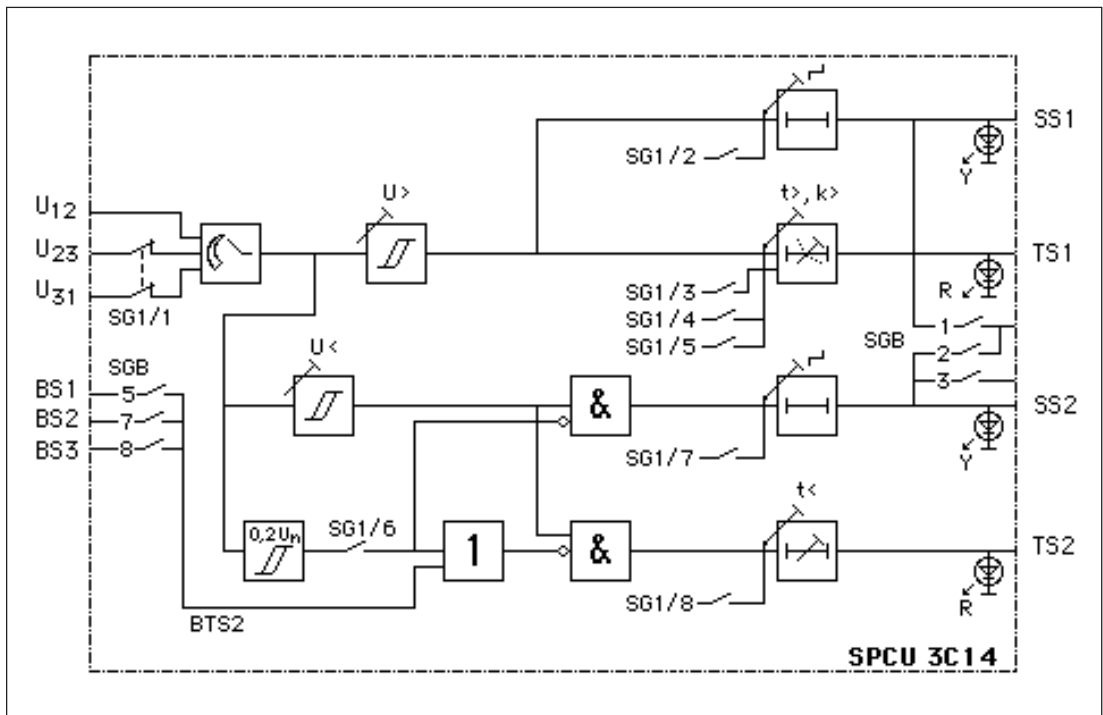

Fig. 2. Block diagram for combined overvoltage and undervoltage relay module SPCU 3C14.

$U_{12}, U_{23}, U_{31}$	Measured phase-to-phase voltages
BS1, BS2, BS3	Blocking signals
BTS2	Blocking of the tripping of the $U_{<}$ stage
SG1	Front panel programming switchgroup
SG2	Software selector switchgroup for defining the mode of function of the start and operation indicators
SGB	Selector switchgroup for configuration of blockings (on the PC-board)
SS1	Start signal of the $U_{>}$ stage
TS1	Trip signal of the $U_{>}$ stage
SS2	Start signal of the $U_{<}$ stage
TS2	Trip signal of the $U_{<}$ stage
Y	Yellow indicator
R	Red indicator

### NOTE!

All input and output signals of the relay module are not necessarily wired to the terminals of every protection relay unit including the overvoltage and undervoltage relay module.

The signals wired to the terminals are shown in the signal diagram of the concerned protection relay unit, see user's manual.

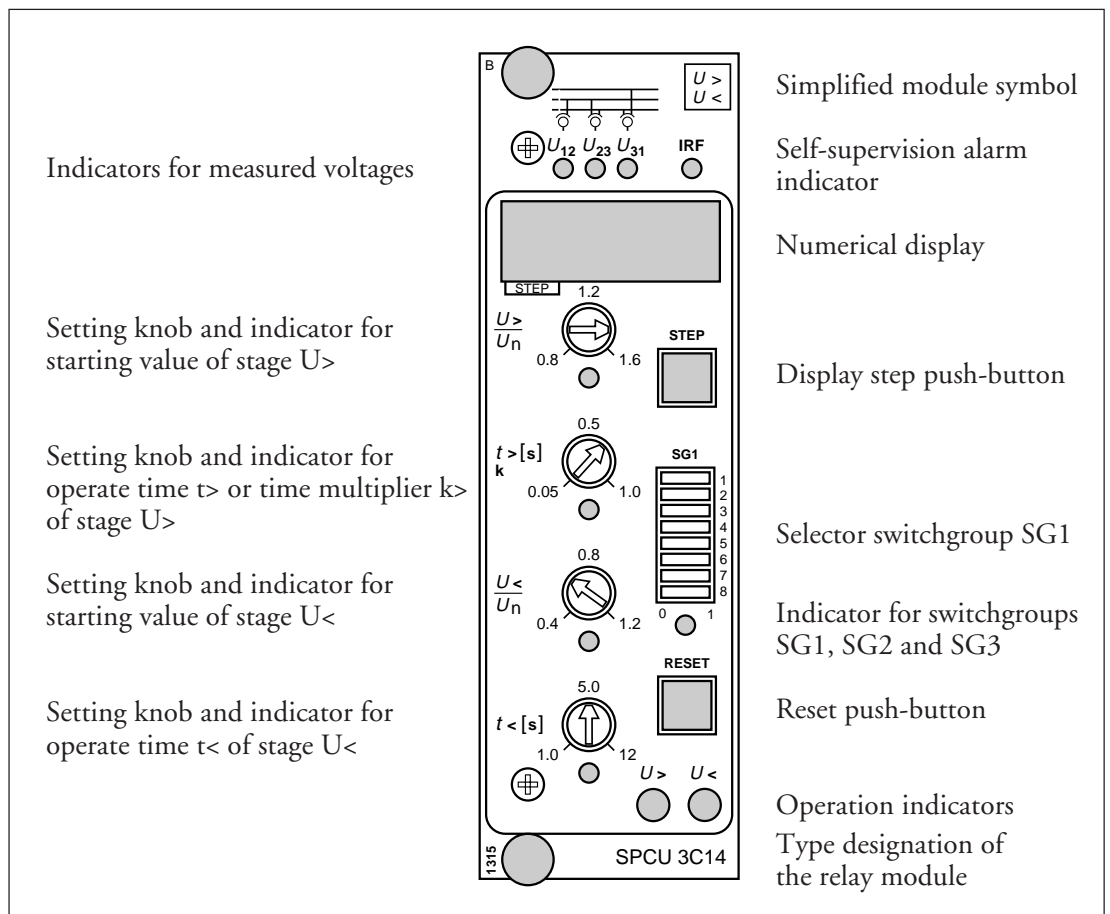

Fig. 3. Front panel of the combined overvoltage and undervoltage relay module SPCU 3C14.

**Start and operation indicators**

Each stage has its own yellow/red operation indicator. Yellow light indicates starting of the operation stage and red light indicates that the stage has delivered a tripping signal.

The four LED indicators can, independently of one another, be given self-reset or manual reset mode of operation with switches in switchgroup SG2. The manual reset mode means that the indicator remains lit after being switched on, although the stage, which controls the indicator, resets. If, for instance, the yellow start indicator has been given self-reset mode of operation and the red operation indicator manual-reset mode of operation, the yellow indicator is lit, when the stage starts and it turns red if the stage operates. When the stage resets after operation the red indication remains lit. If the stage starts but does not operate the yellow indicator is lit during the starting and reset automatically when the stage resets. The indicators, which have been given the manual reset

mode, are reset locally by pushing the RESET push-button on the front panel or by remote control over the SPA bus using the command V101 or V102. See also table (for switchgroup SG3) on page 7 in chapter "Selector switches".

An unreset operation indicator does not affect the protective functions of the relay module. The relay module is constantly operative, regardless of the indicators have been reset or not.

The self-supervision alarm indicator IRF indicates that the self-supervision system has detected a permanent fault. The indicator is lit with red light shortly after a permanent internal fault has been detected. At the same time a control signal is put forward to the output relay of the self-supervision system. Additionally, in most fault cases, a fault code indicating type of fault appears on the display of the relay module. The fault code is to be recorded to serve the subsequent fault location and repair actions.

## Settings

The setting values are shown by the three rightmost green digits of the display. The LED indicator below the setting knob shows, when lit, the setting value currently being shown on the display.

$U>/U_n$	Start value of the U> stage as a multiple of the rated voltage of the relay energizing input. Setting range $0.8...1.6 \times U_n$ .
$t> [s]$	Operate time of the U> stage, expressed in seconds, at definite time mode of k> operation. The required setting range, $0.05...1.00$ s, $0.5...10.0$ s or $5...100$ s, is selected with switches SG1/4 and 5. At IDMT mode of operation the setting range of the multiplier k> is $0.05...1.00$ .
$U</U_n$	Start value of the U< stage as a multiple of the rated voltage of the relay energizing input. Setting range $0.4...1.2 \times U_n$ .
$t< [s]$	Operate time of the U< stage expressed in seconds. The setting range is selected with switch SG1/8, alternatives $1...12$ s and $10...120$ s.

Further, the checksum of the programming switchgroup SG1 is indicated on the display when the indicator under the switchgroup is glowing. In this way a check can be made to prove that the switches have been set and that they work properly. An example of calculating the checksum is given in the description "General characteristics of C-type relay modules".

## Selector switches (Modified 99-12)

When the module has been given single-phase operation, only  $U_{12}$  is measured. Additional relay functions required in various applications are selected by means of the selector switches of switchgroup SG1 located on the front panel of the relay module. The numbering of the switches, 1...8, and the switch positions, 0 and 1, are marked on the front panel.

Switch	Function																																													
SG1/1	Selection of three-phase or single-phase operation.  Three-phase operation when SG1/1 = 0. Single-phase operation when SG1/1 = 1.																																													
SG1/2	Start time selection for the overvoltage stage U>.  When SG1/2 = 0, the start time is 0.1 s. When SG1/2 = 1, the start time is 30 s.																																													
SG1/3 SG1/4 SG1/5	Selection of definite time or IDMT mode of operation for the U> stage. At definite time mode of operation switches 4 and 5 are used for selecting the setting range of the operate time t>. At IDMT mode of operation switch 4 is used for selecting the inverse time curve, switch 5 has no function.																																													
	<table border="1"> <thead> <tr> <th>SG1/3</th> <th>SG1/4</th> <th>SG1/5</th> <th>Mode of operation</th> <th>Operate time t&gt; or characteristic curve</th> </tr> </thead> <tbody> <tr> <td>0</td> <td>0</td> <td>0</td> <td>Definite time</td> <td><math>0.05...1.00</math> s</td> </tr> <tr> <td>0</td> <td>0</td> <td>1</td> <td>Definite time</td> <td><math>0.5...10.0</math> s</td> </tr> <tr> <td>0</td> <td>1</td> <td>0</td> <td>Definite time</td> <td><math>0.5...10.0</math> s</td> </tr> <tr> <td>0</td> <td>1</td> <td>1</td> <td>Definite time</td> <td><math>5...100</math> s</td> </tr> <tr> <td>1</td> <td>0</td> <td>0</td> <td>Inverse time</td> <td>Curve A</td> </tr> <tr> <td>1</td> <td>0</td> <td>1</td> <td>Inverse time</td> <td>Curve A</td> </tr> <tr> <td>1</td> <td>1</td> <td>0</td> <td>Inverse time</td> <td>Curve B</td> </tr> <tr> <td>1</td> <td>1</td> <td>1</td> <td>Inverse time</td> <td>Curve B</td> </tr> </tbody> </table>	SG1/3	SG1/4	SG1/5	Mode of operation	Operate time t> or characteristic curve	0	0	0	Definite time	$0.05...1.00$ s	0	0	1	Definite time	$0.5...10.0$ s	0	1	0	Definite time	$0.5...10.0$ s	0	1	1	Definite time	$5...100$ s	1	0	0	Inverse time	Curve A	1	0	1	Inverse time	Curve A	1	1	0	Inverse time	Curve B	1	1	1	Inverse time	Curve B
SG1/3	SG1/4	SG1/5	Mode of operation	Operate time t> or characteristic curve																																										
0	0	0	Definite time	$0.05...1.00$ s																																										
0	0	1	Definite time	$0.5...10.0$ s																																										
0	1	0	Definite time	$0.5...10.0$ s																																										
0	1	1	Definite time	$5...100$ s																																										
1	0	0	Inverse time	Curve A																																										
1	0	1	Inverse time	Curve A																																										
1	1	0	Inverse time	Curve B																																										
1	1	1	Inverse time	Curve B																																										

Switch	Function
SG1/6	<p>Selection of automatic blocking of starting and tripping of the undervoltage stage U&lt;.</p> <p>When SG1/6 = 0, the undervoltage stage always operates when a measured voltage falls below the setting value.</p> <p>When SG1/6 = 1, starting and tripping of the undervoltage stage are blocked if one of the measured voltages, falls to a value below <math>0.2 \times U_n</math>.</p> <p>This feature can be used for preventing unnecessary startings and trippings during auto-reclose sequences.</p>
SG1/7	<p>Start time selection for the undervoltage stage U&lt;.</p> <p>When SG1/7 = 0, the start time is 0.1 s.</p> <p>When SG1/7 = 1, the start time is 30 s.</p>
SG1/8	<p>Selection of the setting range for the operate time <math>t_{&lt;}</math> of the undervoltage stage U&lt;.</p> <p>When SG1/8 = 0, the setting range of the operate time is 1.0...12.0 s.</p> <p>When SG1/8 = 1, the setting range of the operate time is 10...120 s.</p>

Switchgroup SG2 is a so called software switchgroup, which is located in the third submenu of the checksum register of switchgroup SG1. The mode of operation, i.e. self-reset or manually reset, of the LED indicators U> and U< is determined by the switches of switchgroup SG2.

The mode of operation can be separately set for each indicator. The mode of operation is set by means of the checksum, which can be calculated from the following table. Normally the start indications are self-reset and the operation indications manually reset.

Indicator	Manually reset	Factory default
Start indicator U>	1	0
Operation indicator U>	2	2
Start indicator U<	4	0
Operation indicator U<	8	8
Checksum	15	10

Switchgroup SG3 is a so called software switchgroup, which is located in the fourth submenu of switchgroup SG1. The front panel push-

buttons STEP and RESET can be programmed with switch SG3/1. Switches SG3/2...8 are not in use. The default value for SG3 is 0.

SG3/1	Push-button	Clear start/trip LED's	Erase memorized values
0	STEP RESET STEP & RESET	x x	x
1	STEP RESET STEP & RESET	x x x	x

The PC-board of the relay module contains a switchgroup SGB with eight switches. The switches 1...3 are used for configuring the start signals going from the module, whereas the switches 5, 7 and 8 are used for configuring the blocking signals applied on the undervoltage

stage in various protection relay units. Switches 4 and 6 have no function in the relay module SPCU 3C14. Instructions for setting the switchgroup SGB are given in the user's manual of the protection relay unit and in the signal diagram of the relay.

## Measured data

The measured values are presented with the rightmost three green digits on the display. The data being presented are indicated by LED indicators on the front panel.

Indicator	Measured data
$U_{12}$	The $U_{12}$ voltage measured by the module expressed as a multiple of the rated voltage of the relay energizing input.
$U_{23}$	The $U_{23}$ voltage measured by the module expressed as a multiple of the rated voltage of the relay energizing input.
$U_{31}$	The $U_{31}$ voltage measured by the module expressed as a multiple of the rated voltage of the relay energizing input.

## Recorded information

The leftmost red digit on the display indicates the register address and the three rightmost digits the recorded information.

Register/ STEP	Recorded information
1	The highest voltage value measured during the start sequence as a multiple of the rated voltage of the relay energizing input. Any overvoltage stage start erases the old value and starts a new recording sequence. The recording sequence is stopped on operation of the overvoltage stage and the highest value during the start sequence is found in the register.
2	The highest voltage value measured as a multiple of the rated voltage of the relay energizing input. The register value is updated as soon as the measured value exceeds the value already in the register. Register 2 is erased with a command via the serial port or by pushing the STEP and RESET push-buttons simultaneously. The registered value is also erased on loss of auxiliary supply.
3	The lowest voltage value measured during the start sequence as a multiple of the rated voltage of the relay energizing input. Any undervoltage stage start erases the old value and starts a new recording sequence. The recording sequence is stopped on operation of the undervoltage stage and the lowest value during the start sequence is found in the register.
4	The lowest voltage value measured as a multiple of the rated voltage of the relay energizing input. The register value is updated as soon as the measured value falls below the value already in the register. Register 4 is erased with a command via the serial port or by pushing the STEP and RESET push-buttons simultaneously. The registered value is also erased on loss of auxiliary supply.
5	Number of starts of the overvoltage stage, $n(U>) = 0...255$ .
6	Number of starts of the undervoltage stage, $n(U<) = 0...255$ .
7	Duration of the latest start event of the overvoltage stage, expressed as a percentage of the set operate time $t_{>}$ , or, at IDMT mode of operation, of the calculated operate time. A new start resets the counter which starts recounting from zero. If the stage has tripped, the counter reading is 100.
8	Duration of the latest start event of the undervoltage stage, expressed as a percentage of the set operate time $t_{<}$ . A new start resets the counter which starts recounting from zero. If the stage has tripped, the counter reading is 100.

Register/ STEP	Recorded information
0	<p>Display of blocking signals and other external control signals. The digit at the extreme right indicates the state of the blocking of the undervoltage stage. The following states are indicated:  0 = no blockings  2 = tripping of the undervoltage stage blocked</p> <p>The middle digit of the register is always a zero. The leftmost green digit indicates the state of the remote reset input, if any. The following states are indicated:  0 = remote reset control input not energized  1 = remote reset control input energized</p> <p>From this register it is possible to move on to the TEST mode, where the starting and tripping signals of the module can be activated one by one. For further details see the description "General characteristics of C-type relay modules".</p>
A	<p>The address code of the measuring relay module, required by the serial communication system.</p> <p>Submenu 1: Selection of the data transfer rate.</p> <p>Submenu 2: Bus traffic monitor. If the relay module is connected to a data communication system and the communication is operating, the counter reading of the bus traffic monitor will be 0. Otherwise the numbers 0...255 are continuously rolling in the counter.</p> <p>Submenu 3: Password required for remote setting. The password given in the setting mode of a submenu must always be entered via the serial communication before the settings can be altered remotely.</p>

When the display is dark, the register can be re-entered by pressing the STEP push-button.

The registers 1...8 are cleared by pressing the push-buttons STEP and RESET simultaneously or via the SPA bus with the command V102. The registers are also cleared if the auxiliary power supply to the module is interrupted. The address code of the relay module, the data transfer rate of the serial communication system

and the password of the module are not affected by voltage failures. The instructions for setting the address and the data transfer rate are given in the manual "General characteristics of C-type relay modules".

At the initial state when none of the stages has started, the reading of register 1 is "000" and that of register 3 is "--"

# Menu chart

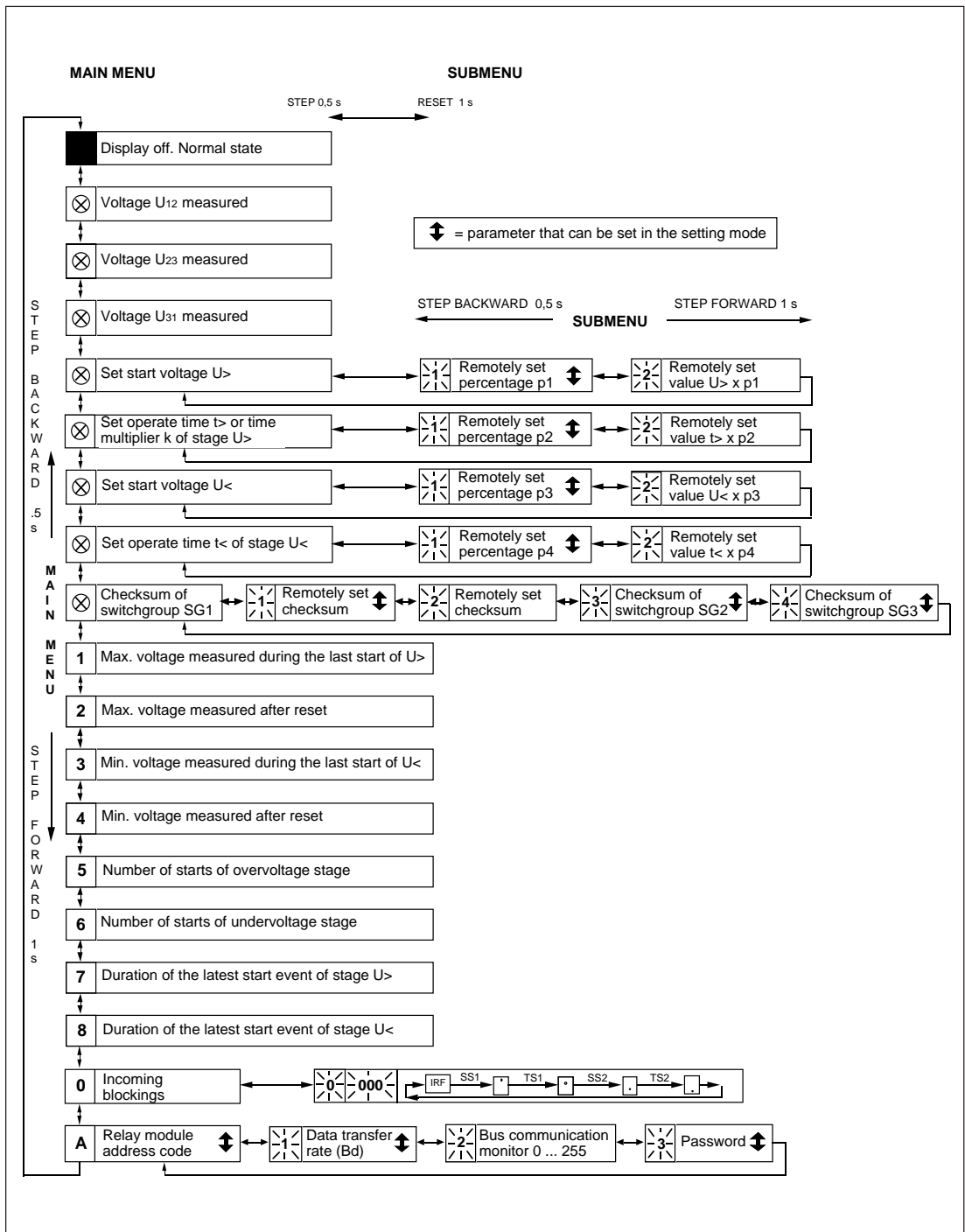

Fig. 4. Main menus and submenus of the combined overvoltage and undervoltage relay module SPCU 3C14.

The procedure for entering a submenu or a setting mode and configuring the module is described in detail in "General characteristics of C type relay modules".



**Voltage/time characteristic**  
(Modified 99-10)

At inverse time characteristic the operate time of the overvoltage stage will be shorter the greater the deviation from the setting value.

The operation of the U> stage is based on inverse time characteristic, when the selector switch SG1/3 on the front panel is in position 1. The relationship between time and voltage at inverse time characteristic can be expressed as follows:

$$t = \frac{k > \times a}{(b \times \frac{U - U >}{U >} - 0.5)^p} + c$$

- where t = operate time [s]  
 k > = time multiplier  
 U = measured voltage [V]  
 U > = set start voltage [V]  
 a = constant 480  
 b = constant 32  
 c = constant 0.035  
 p = constant

At an IDMT mode of operation the recording of the tripping time of the overvoltage stage does not start until the voltage exceeds the setting value by 6%. The operating time accuracy stated in the technical data applies when the voltage exceeds the setting value by 10%. The overvoltage stage includes two characteristics with different inversities. The characteristic is selected with the programming switch SG1/4. The degree of inversivity is determined by the factor p as follows:

Characteristic	p (constant)
A	2
B	3

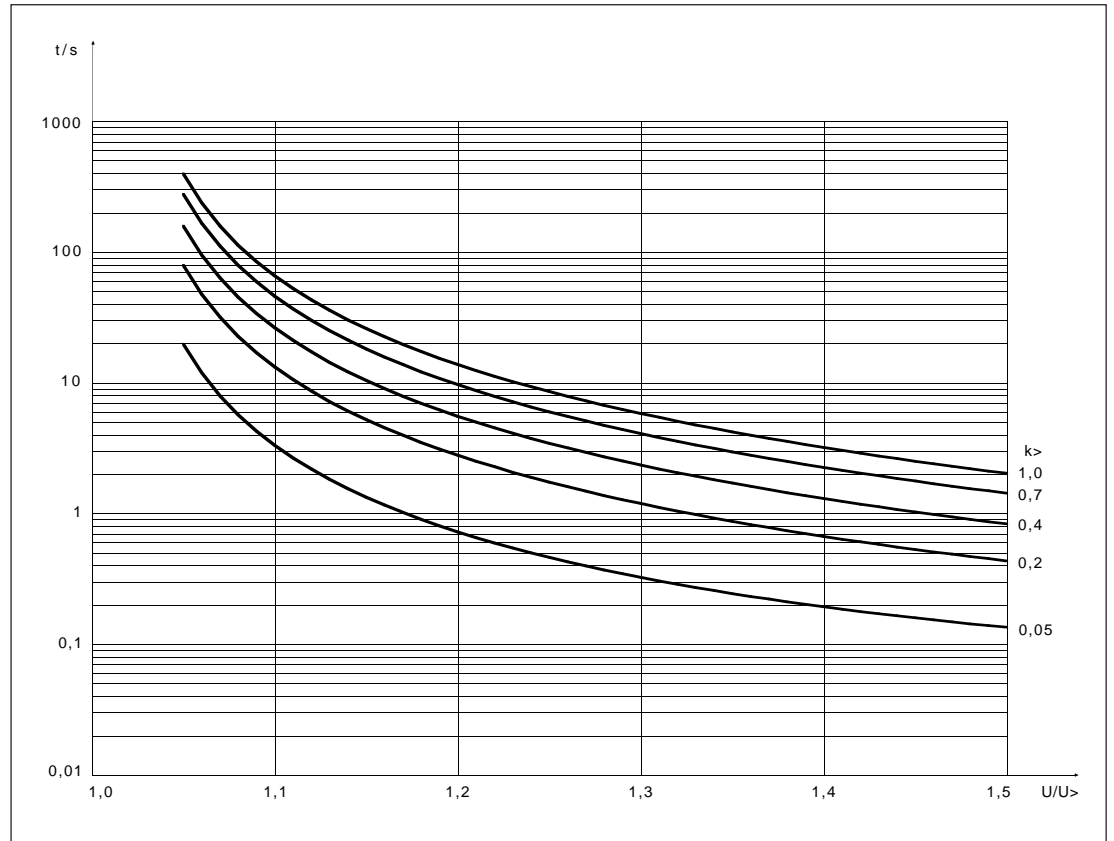

Fig. 5. Characteristic curve set A of overvoltage stage U>.

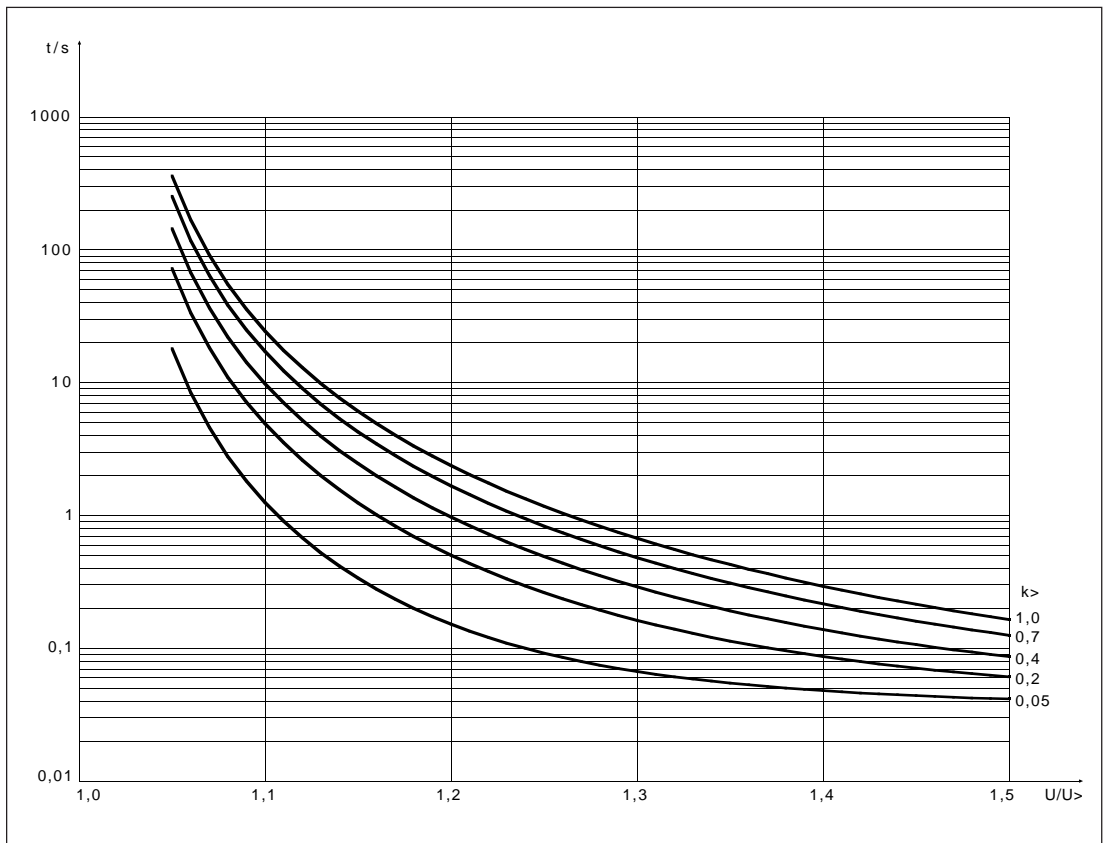

Fig. 6. Characteristic curve set B of overvoltage stage  $U>$ .

## Technical data

### Overvoltage stage $U>$

Start voltage $U>$	$0.8 \dots 1.6 \times U_n$
Start time	0.1 s or 30 s
Operate time at definite time mode of operation	0.05...1.00 s, 0.5...10.0 s or 5...100 s
Time multiplier $k>$ at inverse time characteristic	0.05...1.00
Reset time, typically	60 ms
Drop-off/pick-up ratio, typically	0.97
Operate time accuracy at definite time mode of operation and start time accuracy	$\pm 2\%$ of set value or $\pm 25$ ms
Operate time accuracy at inverse time characteristic	$\pm 25$ ms or the inaccuracy appearing when the measured voltage varies $\pm 3\%$
Operation accuracy	$\pm 3\%$ of set value

### Undervoltage stage $U<$

Start voltage $U<$	$0.4 \dots 1.2 \times U_n$
Start time	0.1 s or 30 s
Operate time at definite time characteristic	1...12 s or 10...120 s
Reset time, typically	60 ms
Drop-off/pick-up ratio, typically	1.03
Operate time accuracy and start time accuracy	$\pm 2\%$ of set value or $\pm 25$ ms
Operation accuracy	$\pm 3\%$ of set value

## Serial communication parameters

### Event codes

The substation level control data communicator is able to read, over the SPA serial bus, the event data of the module, e.g. starting and tripping, from the over-/undervoltage relay module SPCU 3C14. Event information called for are printed out in the format: time (ss.sss) and event code. The event codes of the module are E1...E8, E50 and E51. Furthermore, the substation level control data communicator is able to form event codes relating to e.g. the data communication.

The codes E1...E8 and the events represented by these can be included in or excluded from the event reporting by writing, over the SPA bus, a so called event mask (V155) to the module. The event mask is a binary number coded to a decimal number. The event codes E1...E8 are

represented by the numbers 1, 2, 4...128. The event mask is formed by multiplying above numbers either by 0 (event not included in reporting) or 1 (event included in reporting) and adding up the numbers received (compare calculation of checksum).

The event mask may have a value in the range 0...255. The default value of the over-/undervoltage relay module SPCU 3C14 is 85, which means that all startings and trippings are included in the reporting, but not the resetting. The codes E50...E54 and the events represented by these cannot be excluded from the reporting.

Event codes for over-/undervoltage relay module SPCU 3C14:

Code	Event	Weighting coefficient	Default setting
E1	Starting of overvoltage stage U>	1	1
E2	Starting of overvoltage stage U> reset	2	0
E3	Tripping of overvoltage stage U>	4	1
E4	Tripping of overvoltage stage U> reset	8	0
E5	Starting of undervoltage stage U<	16	1
E6	Starting of undervoltage stage U< reset	32	0
E7	Tripping of undervoltage stage U<	64	1
E8	Tripping of undervoltage stage U< reset	128	0
Default value of event mask V155			85

E50	Restart of microprocessor	*	-
E51	Overflow of event register	*	-
E52	Temporary interruption in data communication	*	-
E53	No response from the relay module over the data communication bus	*	-
E54	The module responds again over the data communication bus	*	-

- 0 not included in event reporting
- 1 included in event reporting
- \* no code number, always included in event reporting
- cannot be set

#### NOTE!

In the SPACOM system the event codes E52...E54 are generated by the station level control data communicator, e.g. type SRIO 1000M.

Data to be transferred over the serial bus  
(Modified 99-12)

In addition to the event code data transfer, the input data (I data), output data (O data), setting values (S), memorized data (V data) and some other data can be read from the relay

module over the serial communication bus. Further, part of the data can be changed over the SPA bus by separate commands. All data information is available in channel 0.

Data	Code	Data direct.	Values
Measured voltage $U_{12}$	I1	R	0...9.99 x $U_n$
Measured voltage $U_{23}$	I2	R	0...9.99 x $U_n$
Measured voltage $U_{31}$	I3	R	0...9.99 x $U_n$
Blocking of tripping of undervoltage stage	I4	R	0 = no blocking 1 = tripping of stage $U<$ blocked
Starting of overvoltage stage $U>$	O1	R	0 = $U>$ stage not started 1 = $U>$ stage started
Tripping of overvoltage stage $U>$	O2	R	0 = $U>$ stage not tripped 1 = $U>$ stage tripped
Starting of undervoltage stage $U<$	O3	R	0 = $U<$ stage not started 1 = $U<$ stage started
Tripping of undervoltage stage $U<$	O4	R	0 = $U<$ stage not tripped 1 = $U<$ stage tripped
Activated start value for stage $U>$	S1	R	0.8...1.6 x $U_n$
Activated operate time $t>$ or time multiplier $k$ for stage $U>$	S2	R	0.05...100 s or 0.05...1.00
Activated start value for stage $U<$	S3	R	0.4...1.2 x $U_n$
Activated operate time for stage $U<$	S4	R	1...120 s
Activated checksum of switchgroup SG1	S5	R	0...255
Start value for stage $U>$ , set with the setting knob	S11	R	0.8...1.6 x $U_n$
Operate time or time multiplier for stage $U>$ , set with the setting knob	S12	R	0.05...100 s or 0.05...1.00
Start value for stage $U<$ , set with the setting knob	S13	R	0.4...1.2 x $U_n$
Operate time for stage $U<$ , set with the setting knob	S14	R	1...120 s
Checksum of switchgroup SG1 (set with the switches)	S15	R	0...255
Remote setting percentage of the start value for stage $U>$	S21	R, W	0...999%
Remote setting percentage of operate time or time multiplier for stage $U>$	S22	R, W	0...999%
Remote setting percentage of start value for stage $U<$	S23	R, W	0...999%
Remote setting percentage of operate time for stage $U<$	S24	R, W	0...999%
Remotely set checksum of switchgroup SG1	S25	R, W	0...255

Data	Code	Data direct.	Values
Remotely set start value for stage U>	S31	R	0.8...1.6 x U <sub>n</sub>
Remotely set operate time or time multiplier for stage U>	S32	R	0.05...100 s or 0.05...1.00
Remotely set start value for stage U<	S33	R	0.4...1.2 x U <sub>n</sub>
Remotely set operate time for stage U<	S34	R	1...120 s
Remotely set checksum of switchgroup SG1	S35	R	0...255
Max. voltage measured when stage U> started	V1	R	0...9.99 x U <sub>n</sub>
Max. voltage measured after resetting	V2	R	0...9.99 x U <sub>n</sub>
Min. voltage measured when stage U< started	V3	R	0...9.99 x U <sub>n</sub>
Min. voltage measured after resetting	V4	R	0...9.99 x U <sub>n</sub>
Number of starts of overvoltage stage	V5	R	0...255
Number of starts of undervoltage stage	V6	R	0...255
Duration of the latest start event of stage U>	V7	R	0...100%
Duration of the latest start event of stage U<	V8	R	0...100%
Resetting of output relays and operation indicators	V101	W	1 = output relays and operation indicators reset
Resetting of output relays, operation indicators and erasing of recorded data simultaneously	V102	W	1 = output relays, operation indicators reset and registers (codes V1...V8) erased
Remote control of settings	V150	R, W	0 = setting with knobs S11...S15 activated 1 = remote settings S31...S35 activated
Event mask word	V155	R, W	0...255, see section "Event codes"
Manual reset or self-reset mode of operation of the LED indicators (SG2)	V156	R, W	0...15, see section "Selector switches"
Programming push-buttons (SG3)	V157	R, W	0...1, see section "Selector switches"
Opening of password for remote settings	V160	W	1...999
Changing or closing of password for remote settings	V161	W	0...999
Activation of self-supervision function	V165	W	1 = self-supervision output is activated and IRF indicator turns on in about 5 seconds, whereafter the self-supervision system and the IRF indicator reset
Internal fault code	V169	R	0...255
Data communication address of the relay module	V200	W	1...254
Program version	V205	R	072_

Data	Code	Data direct.	Values
Type designation of the relay module	F	R	SPCU 3C14
Reading of event register	L	R	Time, channel number and event code
Re-reading of event register	B	R	Time, channel number and event code
Reading of module status data	C	R	0 = normal state 1 = module been subject to automatic reset 2 = overflow of event register 3 = events 1 and 2 together
Resetting of module status data	C	W	0 = resetting
Time reading or setting	T	R, W	00.000...59.999 s

R = data to be read from the module  
W = data to be written to the module

The data transfer codes L, B, C and T have been reserved for the event data transfer between the relay module and the control data communicator.

The event register can be read by the L command only once. Should a fault occur, for example, in the data transfer, it is possible, by using the B command, to re-read the contents of the event register once already read by means of the L command. When required, the B command can be repeated.

The setting values S1...S5 are the alerted set values currently used by the protection relay module. These values are set either by remote control or by means of the setting knobs. The values S11...S15 are set with the setting knobs and the selector switches. Variables S21...S25 are set as percentage values via remote control.

The settings S21...S25 allow reading or writing. A condition for writing is that the password V160, for remote setting has been opened. The variables S31...S35 contain the remote setting values.

When the values of the variables S21...S24 are to be changed, the variables can be given a percentage factor within the range 0...999. It is possible to alter a setting value beyond the setting ranges specified in the technical data of the relay module. However, the validity of the setting values are guaranteed only within the setting ranges specified in the technical data.

Activation of the self-supervision function (V165) prevents the relay module from operating as long as the self-supervision output is activated and the IRF indicator is lit.

## Fault codes

Once the self-supervision system has detected a permanent relay fault, the IRF LED on the front panel of the module is lit, and at the same time the normally operated signal relay of the self-supervision system drops off.

In most fault situations an auto-diagnostic fault code is shown on the relay display. The fault code cannot be reset. The fault code consists of

a red digit one (1) and a green code number that indicates the fault type. The fault code should be recorded and stated when service is ordered.

The fault codes of the over-/undervoltage relay module SPCU 3C14 are explained in the following table:

Fault code	Explanation
4	Faulty output relay path or missing output relay card
30	Faulty program memory (ROM)
50	Faulty working memory (RAM)
195	Too low a value in reference channel with multiplier 1
131	Too low a value in reference channel with multiplier 5
67	Too low a value in reference channel with multiplier 25
203	Too high a value in reference channel with multiplier 1
139	Too high a value in reference channel with multiplier 5
75	Too high a value in reference channel with multiplier 25
253	No interruptions from the A/D-converter





# General characteristics of C-type relay modules

## User's manual and Technical description

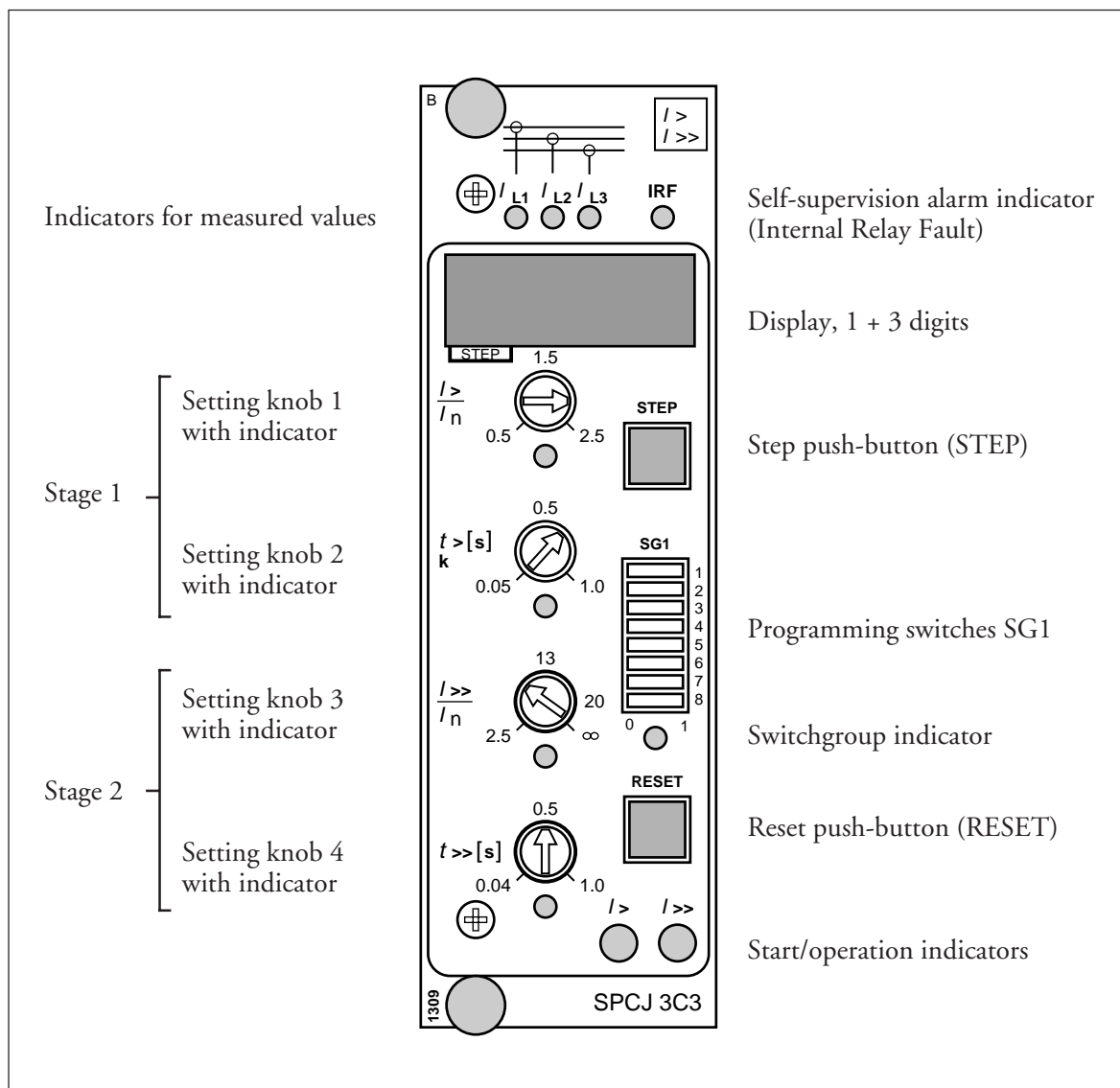

Data subject to change without notice

## Contents

Push-buttons .....	2
Programming switches SG1 .....	2
Setting knobs .....	3
Display .....	3
Display main menu .....	3
Display submenu .....	4
Setting mode .....	4
Example: Operation in setting mode .....	5
Stored information .....	6
Trip-test mode.....	7
Example: Trip-test function .....	8
Operation indicators .....	9
Fault codes.....	9

## Push-buttons

The front panel of the relay module contains two push-buttons. The STEP button is used for stepping forward in the display and the RESET button for resetting the red indicators. Additionally, the push-buttons are used for certain

settings, e.g. for setting the address of the relay module and the data transfer rate for the serial communication when the modules are used in relay packages provided with this quality. (See section Display).

## Programming switches SG1

Part of the settings and the selections of the operating characteristics for the relay modules in various applications are made with the programming switches SG1 on the front panel. The indicator of the switchgroup glows when the

checksum of the switchgroup is shown on the display. The checksum can be used for checking that the switches are properly set. Fig. 2 gives an example of calculating the checksum.

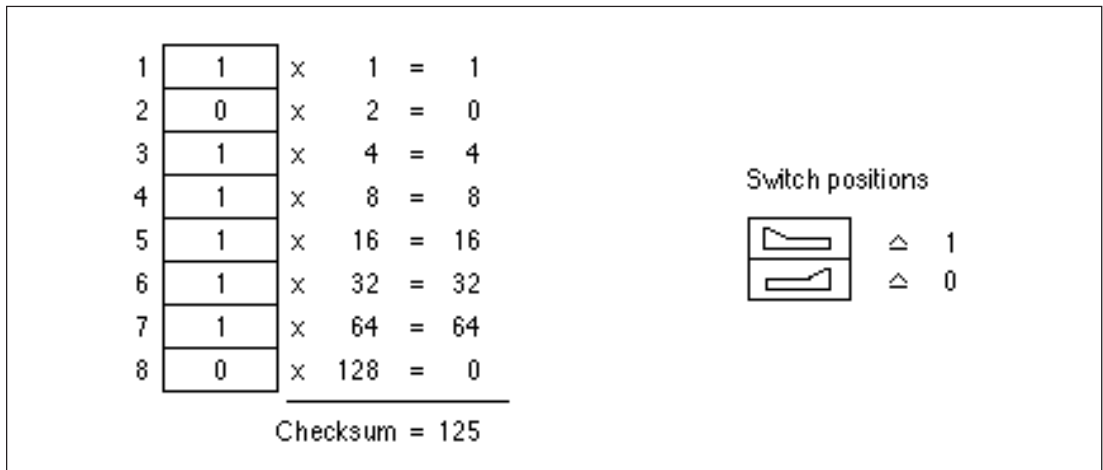

Fig. 2. Example of calculating the checksum of programming switchgroup SG1.

When the checksum calculated according to the example is equal to the checksum indicated on the display of the relay module, the switches are properly set.

The function of the programming switches of the individual measuring relay modules is specified in the description of the module concerned.

## Setting knobs

Most of the operating values and operating times are set by means of the setting knobs on the front panel of the relay module. Each setting knob has its own (LED) indicator which glows when the concerned setting value is shown on the display.

If a setting knob is turned while the display is showing another measured or set value, the value being set automatically appears on the display. Simultaneously, the indicator for the concerned setting starts glowing.

In addition to the settings made with the setting knobs, most modules allow so called remote setting. This means that the settings made by means of the setting knobs of the module and the checksum of the programming switchgroup may be altered through an instruction over the serial communication bus. Remote setting is possible if the password in the register A is known, and the remote settings are not activated, i.e. parameter V150=0. The circumstance that the remote settings are activated is shown with a flashing light of the indicator of the setting knob, the value of which currently is being displayed.

---

## Display

The measured and set values as well as the data recorded are shown on the display of the measuring relay module. The display consists of four digits. The three digits (green) to the right indicate the measured, set or stored value and the digit at the extreme left (red) the number of the register. The measured or set value displayed is indicated by a yellow LED indicator. The number of the register glows only when a stored value is displayed.

When the auxiliary voltage is connected to a measuring relay module, the module initially tests the display by stepping through the digits 1...9 for about 15 seconds. When the test is finished the display turns dark. The testing can be interrupted by pressing the STEP button. The protective functions of the module are operative throughout the testing.

---

## Display main menu

All the data required during normal operating conditions are accessible from the main menu which presents the measured values in real-time, the normal setting knob settings as well as the most important memorized data.

The data to be shown in the main menu are selected to the display in a certain sequence by means of the STEP button. When pressing the STEP button for about one second, the display moves forward in the display sequence. When pressing it for about 0.5 seconds, the display moves backwards in the display sequence.

From a dark display only forward movement is possible. When keeping the STEP button depressed, the display is continuously moving in forward direction stopping for a while at the dark point.

Unless the display is switched off by stepping to the dark point, it remains activated for about 5 minutes from the last pressing of the STEP button and then goes out.

## Display submenu

Less important values and values not very often set are displayed in the submenus. The number of submenus varies with different relay module types. The submenus are presented in the description of the concerned module.

A submenu is entered from the main menu by pressing the RESET button for about one second. When the button thereafter is released, the red digit (STEP) of the display starts flashing, indicating that one is in a submenu. Going from one submenu to another or back to the main menu follows the same principle as when moving from the main menu display to another; the

display moves forward when pressing the STEP button for one second and backward when pressing it for 0.5 seconds. The return to the main menu has taken place when the red STEP display turns dark.

When entering a submenu from a measured or set value indicated by a LED indicator, the indicator remains glowing and the address window (STEP) of the display starts flashing. A flashing address window when no LED indicator is lit indicates that the submenu of a register has been entered.

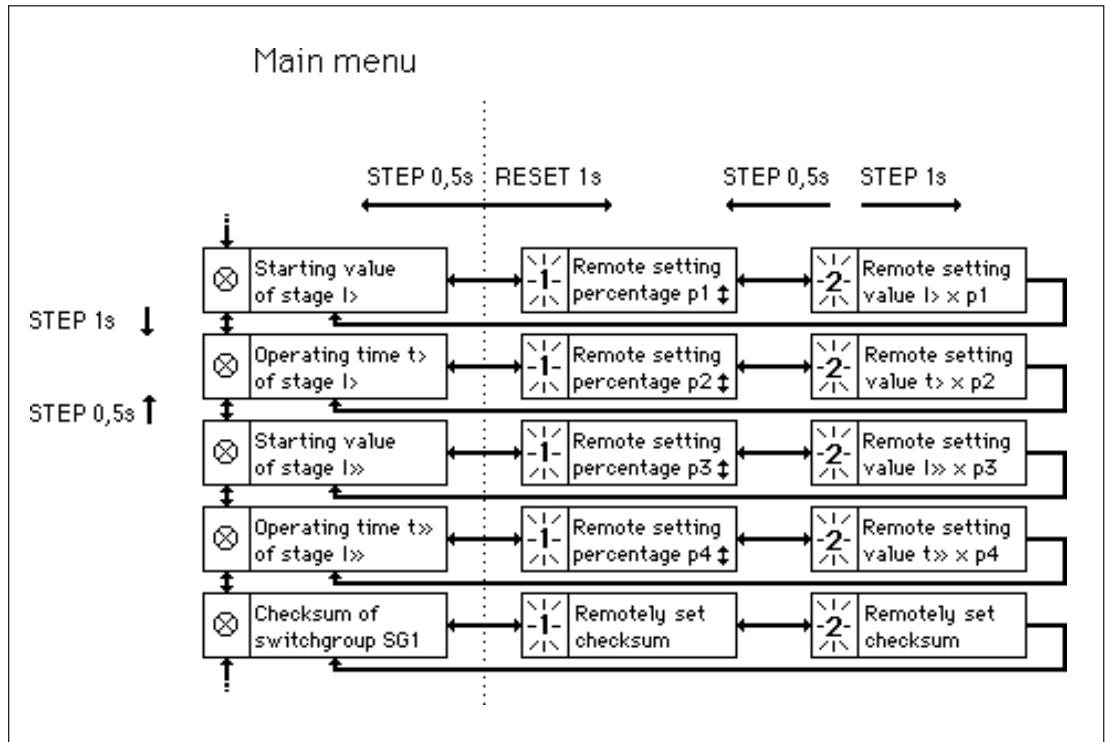

Fig. 3. Example of the main and submenus for the settings of the overcurrent relay module SPCJ 3C3. The settings made with the setting knobs are in the main menu and they are displayed by pressing the STEP button. In addition to the setting knob settings the main menu contains the measured current values as well as the registers 1...5, as well as 0 and A. The remote setting percentage and remote setting value are located in the submenus for the settings and are activated on the display by pressing the RESET button.

## Setting mode

The registers of the main menu and the submenus also contain parameters to be set. The settings are made in the so called setting mode, which is accessible from the main menu or a submenu by pressing the RESET button, until the digit at the extreme right starts flashing (about 10 s). The flashing digit is set by means of the STEP button. The flashing is moved on from digit to digit by pressing the RESET button.

A set value is stored in the memory by pressing the push-buttons STEP and RESET simultaneously. In practice the RESET button must be

pressed slightly in excess of the STEP button. Return from the setting mode to the main menu or submenu is possible by pressing (for about 10 s) the RESET button until the green digits on the display stop flashing. If the module is left in the setting mode, it will return automatically to the start condition after about 5 minutes.

The values to be set in the setting mode are for instance the address code of the relay module and the data transfer rate for the serial communication. Further the percentage values for the remote settings can be changed.

Example 1:

Function in the setting mode. Manual setting of the address code of a relay module and the data transfer rate for the serial communication. The initial value for the address code is 146.

a) Press push-button STEP until register address A appears on the display.

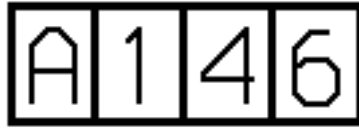

b) Press the RESET button for about 10 s until the right most digit starts flashing.

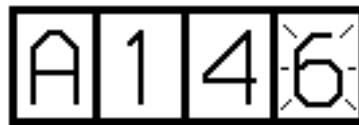

c) Press the STEP button repeatedly to set the digit to the value desired.

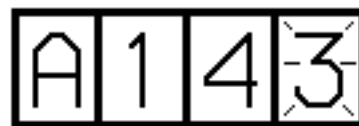

d) Press the RESET button to make the middle of the green digits flash.

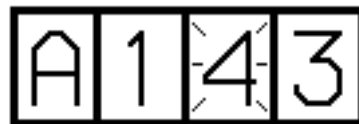

e) Set the middle address digit by means of the STEP button.

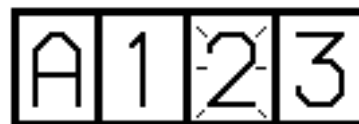

f) Press the RESET button to make the left most green digit flash.

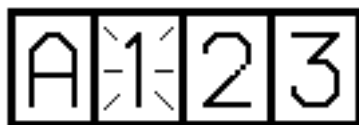

g) Set the digit by means of the STEP button.

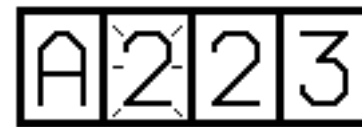

h) Store the set address number in the memory of the relay module by pressing the RESET and STEP button simultaneously. At the moment the information enters the memory, the three green dashes flash in the display, i.e. A—.



i) Leave the setting mode by pressing the RESET button for about 10 s, until the display stops flashing.

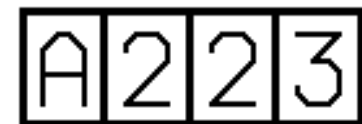

j) Then enter submenu 1 of register A by pressing the RESET button for approx. one second. The register address A is then replaced by a flashing 1. This submenu is used for setting the data transfer rate of the serial communication.



k) The data transfer rate for the serial communication is set and stored in the same way as the address, see sections b...i, except that the continuously glowing register address has been replaced by a flashing 1.

l) After storing the data transfer rate for the serial communication you may return to the main menu of register A by pressing the STEP button for about 0.5 second.

## Stored information

The parameter values measured at the moment when a fault occurs are recorded in the registers, in some modules also the setting values. The recorded data, except for some setting parameters, are set to zero by pressing the push-buttons STEP and RESET simultaneously. The data in normal registers are erased if the auxiliary voltage supply to the relay is disrupted, only the set values and the number of autoreclosings are maintained in the registers at a voltage failure.

The number of the registers varies with different module types. The function of the registers are illustrated in the descriptions of the separate relay modules. Additionally, the system panel contains a simplified list of the data recorded by the various relay modules of the relay assembly.

All C-type relay modules are provided with two general registers: register 0 and register A.

Register 0 contains, in coded form, the information about e.g. external blocking signals and status information for the circuit breaker. The codes are explained in the descriptions of the relay modules.

Register A contains the address code of the relay module as required by the serial communication system. Example 1 on page 4 shows how the address code is altered. Submenu 1 of register A contains the data transfer rate value expressed in kilobaud for the serial communication.

Submenu 2 of register A contains a bus traffic monitor for the SPACOM system. If the protective relay, which contains the relay module, is linked to a system including the control data communicator and the data communication system is operating, the counter reading of the monitor will be zero. Otherwise the digits 1...255 are continuously rolling in the monitor.

Submenu 3 contains the password required for changing the remote settings. The address code, the data transfer rate for the serial communication and the password can be set manually or via the serial communication bus. For manual setting see example 1.

The start value for the address code and the password is 001 and that for the data transfer rate 9.6 kilobaud.

Register 0 also allows access to the so called Trip-test function, which allows the output signals of the relay module to be activated one by one. If the auxiliary relay module of the protection assembly is in place, the auxiliary relays will be included in the testing.

When pressing the RESET button for about 10 seconds, the three green digits to the right start flashing to indicate that the relay module is in test position. The indicators of the setting knobs indicate by flashing which output signal can be activated. The required output function is selected by pressing the RESET button for about 1 second, until the following LED indicator starts flashing.

The indicators of the setting knobs refer to the following output signals:

Setting knob 1	SS1	Starting of stage 1
Setting knob 2	TS1	Tripping of stage 1
Setting knob 3	SS2	Starting of stage 2
Setting knob 4	TS2	Tripping of stage 2
No indication	IRF	Self-supervision

The selected starting or tripping is activated by simultaneous pressing of the push-buttons STEP and RESET. The signal remains activated as long as the two push-buttons are being pressed.

The self-supervision output is activated by pressing the STEP button once when no setting knob indicator is flashing. The IRF output is activated in about 5 seconds after pressing of the STEP button, and resets after that. Simultaneously, the display returns to the main menu and performs the initial testing indicated by rolling digits 0...9 in the display several times.

The signals are selected in the order illustrated in fig. 4.

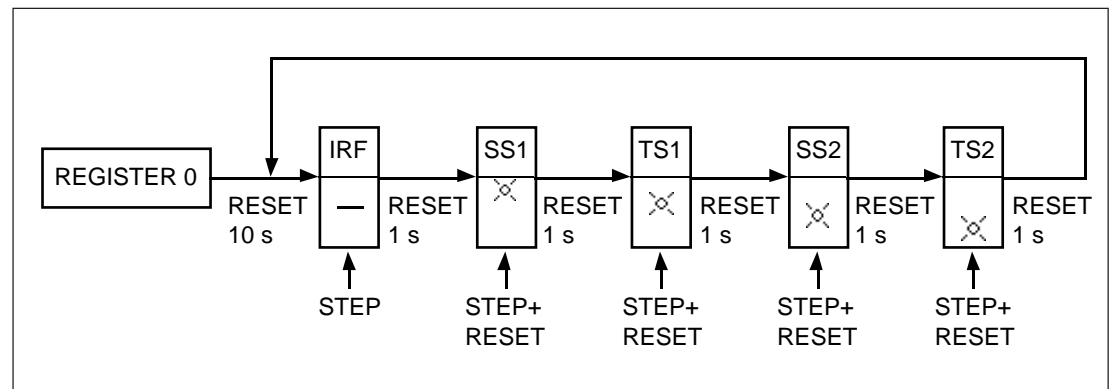

Fig. 4. Sequence order for selecting the output signals in the Trip-test mode.

If e.g. the indicator of the setting knob 2 (second from the top) is flashing, and the push-buttons STEP and RESET are being pressed, the signal TS1 (tripping of stage 1) is activated. Return to the main menu is possible at any stage of the

Trip-test sequence scheme, by pressing the RESET button for about 10 seconds. If the module is left in the Trip-test mode, it will return automatically after approx. 5 minutes.

Example 2:

Trip-test function. Forced activation of the outputs is made as follows:

a) Step forward on the display to register 0.

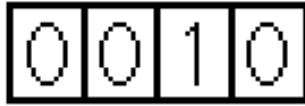

- Indicator switched off
- ◐ Yellow indication
- ◑ Red indication

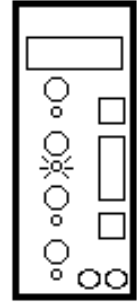
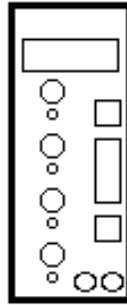

b) Press the RESET button for about 10 seconds until the three green digits to the right and the LED indicator of the uppermost setting knob start flashing.

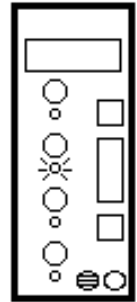
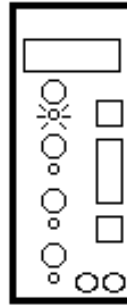

c) Press the push-buttons RESET and STEP simultaneously. Then the starting of stage 1 (e.g. the I>-stage of the overcurrent module SPCJ 3C3) is activated and, simultaneously, the indicator of the stage starts glowing yellow.

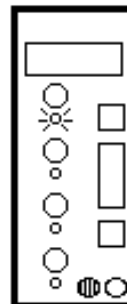

d) Press the RESET button for about 1 second until the indicator of the second setting knob starts flashing.

e) Press the push-buttons RESET and STEP simultaneously to activate tripping of stage 1 (e.g. the I>-stage of the overcurrent module SPCJ 3C3). The indicator of the concerned stage starts glowing red.

f) Starting and tripping of the second stage is activated in the same way as stage 1. The indicator of the third or fourth setting starts flashing to indicate that the concerned stage has been activated.

g) To activate the self-supervision output step towards the test position, where no indicator is flashing. Press the STEP button once. In about 5 seconds the red IRF indicator starts glowing and the IRF output is activated. Shortly thereafter the indicator goes out and the output automatically resets. At the same time the module leaves the test position.

h) It is possible to leave the trip test mode at any step of the sequence scheme by pressing the RESET button for about 10 seconds until the three digits to the right stop flashing.



## Operation indicators

A measuring relay module is provided with two separate operating stages, each of which with its own yellow/red operation indicator on the lower part of the front plate of the relay module.

The operation indicator starts glowing yellow when the operating stage starts and red when a delayed tripping operates. The functions of the start and operation indicators are described in detail in the different protection relay module manuals.

---

## Fault codes

In addition to the protective functions the relay module is provided with a self-supervision system which continuously supervises the function of the microprocessor, its program execution and the electronics.

When the self-supervision system has detected a permanent fault in the relay module, the red IRF indicator on the panel starts glowing soon after the fault was discovered. At the same time the module puts forward a signal to the self-supervision contact of the relay assembly.

In most fault situations a fault code, indicating the nature of the fault, appears on the display of the module. The fault code, which consists of a red digit (1) and a three digit green code number, cannot be removed from the display by resetting. When a fault occurs, the fault code should be recorded and stated when service is ordered.







**ABB Oy**

Substation Automation

P.O.Box 699

FIN-65101 VAASA

Finland

Tel. +358 (0)10 22 11

Fax.+358 (0)10 22 41094

[www.abb.com/substationautomation](http://www.abb.com/substationautomation)