

SETTAGGIO
SETTING

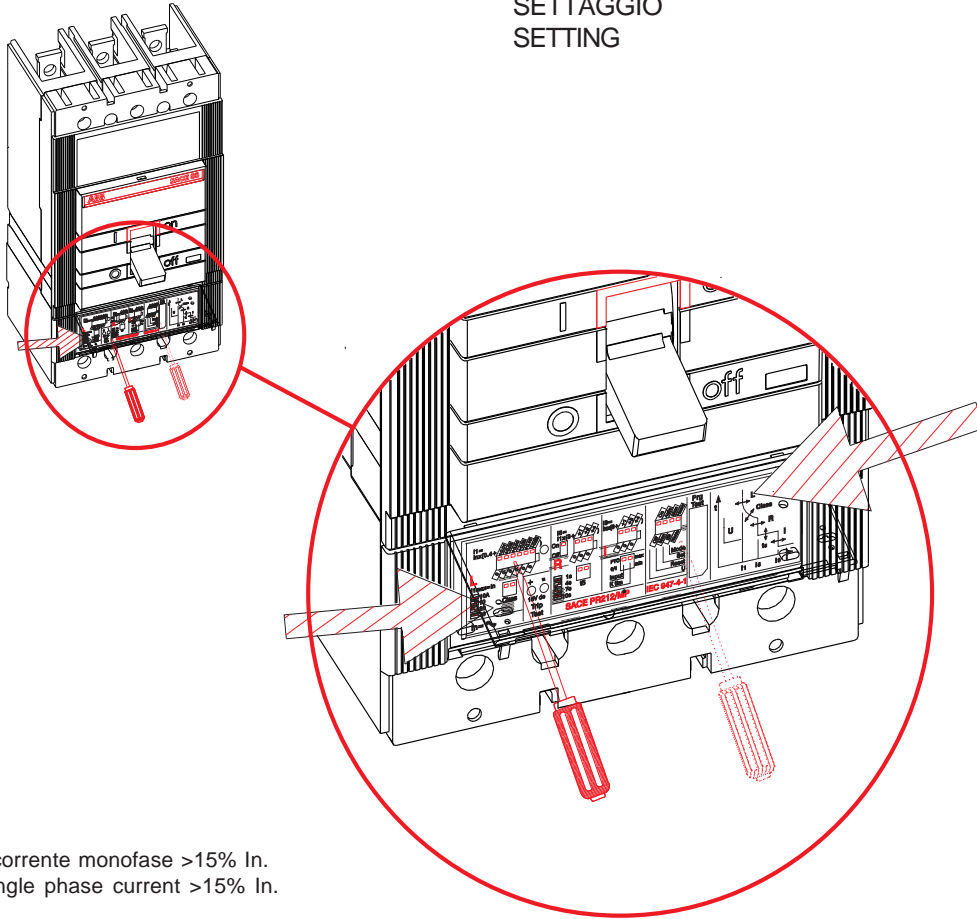

Autoalimentati per corrente monofase >15% In.
Self-powered for single phase current >15% In.

A

Settaggio di default manuale
Manual default setting

S4-S5

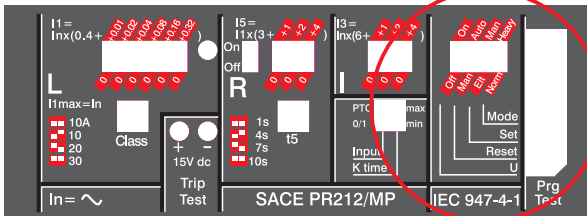

S6-S7

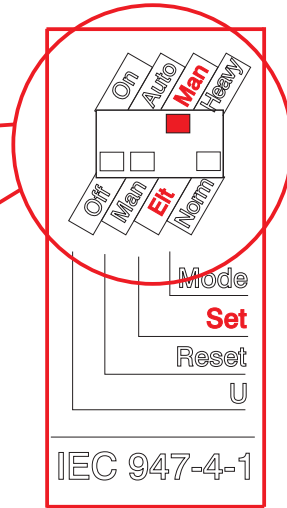
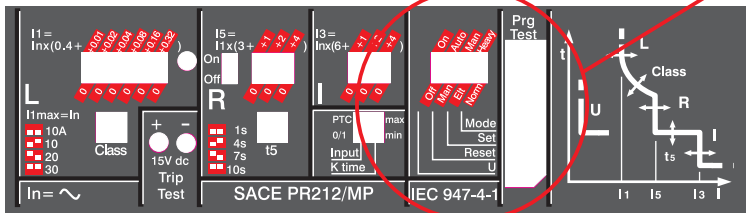

Esempio di settaggio dip-switch/ Dip-switch setting example
 $I1 = 0.88 \times I_n (0.4 + 0.16 + 0.32)$ $t1 = \text{Class } 10$

Soglia
Threshold
I1

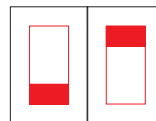

Classe
Class
t1

B

S4-S5

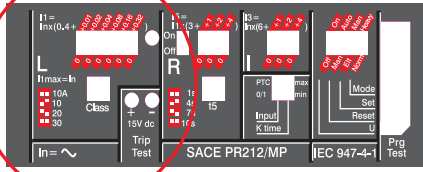

	Iu(A)	In(A)	I1(A)						
			1	0.99	0.98	...	0.42	0.41	0.4
S4	160	100	100	99	98	...	42	41	40
	160	160	160	158.4	156.8	...	67.2	65.6	64
	250	200	200	198	196	...	84	82	80
S5	400	320	320	316.8	313.6	...	134.4	131.2	128
S6	800	630	630	623.7	617.4	...	264.6	258.3	252
S7	1250	1000	1000	990	980	...	420	410	400
S4X	250	100	100	99	98	...	42	41	40
	250	160	160	158.4	156.8	...	67.2	65.6	64
	250	200	200	198	196	...	84	82	80
S6X	400	320	320	316.8	313.6	...	134.4	131.2	128
	630	400	400	396	392	...	168	164	160
	630	630	630	623.7	617.4	...	264.6	258.3	252

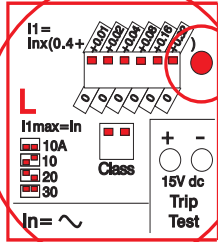

Protection Status	Current	Led Status
Normal	$I < 0,9 I1$	Off
Prealarm	$0,9 I1 < I < 1,1 I1$	On
Alarm	$I > 1,1 I1$	Blink

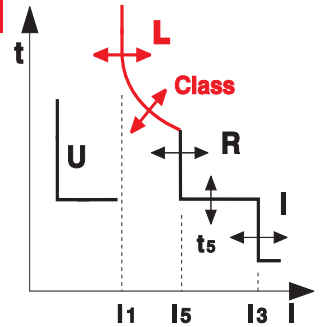

S6-S7

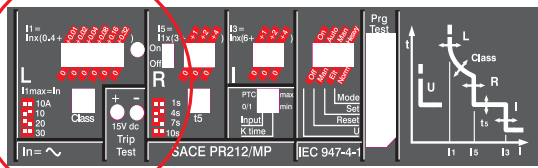

La memoria termica è attiva solo in presenza di alimentazione ausiliaria
 Thermal memory active only with auxiliary supply connected
 Der thermische Speicher ist nur bei Anliegen der Hilfsspannung aktiviert.
 La mémoire thermique n'est active qu'en présence d'une alimentation auxiliaire.
 La memoria térmica funciona sólo en presencia de alimentación auxiliar.

C

S4-S5

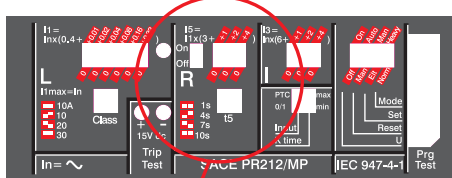

	Iu(A)	In(A)	I5(A)							
			3	4	5	6	7	8	9	10
S4	160	100	300	400	500	600	700	800	900	1000
	160	160	480	640	800	960	1120	1280	1440	1600
	250	200	600	800	1000	1200	1400	1600	1800	2000
S5	400	320	960	1280	1600	1920	2240	2560	2880	3200
S6	800	630	1890	2520	3150	3780	4410	5040	5670	6300
S7	1250	1000	3000	4000	5000	6000	7000	8000	9000	10000
S4X	250	100	300	400	500	600	700	800	900	1000
	250	160	480	640	800	960	1120	1280	1440	1600
	250	200	600	800	1000	1200	1400	1600	1800	2000
S6X	400	320	960	1280	1600	1920	2240	2560	2880	3200
	630	400	1200	1600	2000	2400	2800	3200	3600	4000
	630	630	1890	2520	3150	3780	4410	5040	5670	6300

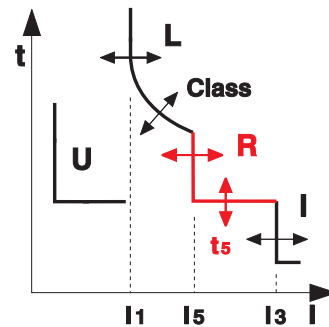
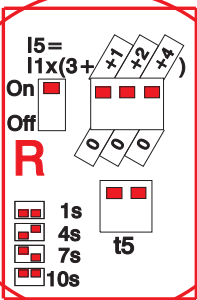

S6-S7

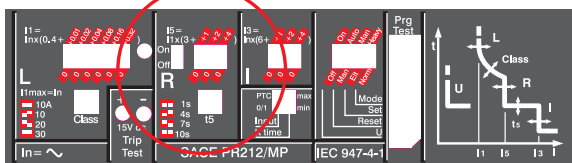

D

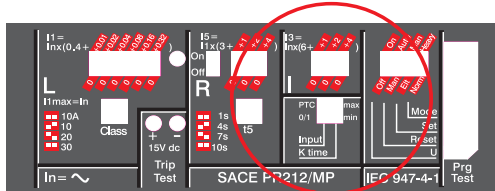

S4-S5

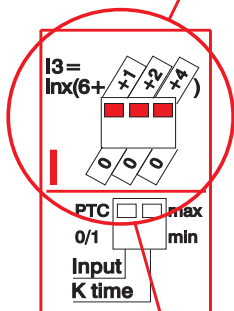

	Iu(A)	In(A)	I3(A)							
			6	7	8	9	10	11	12	13
S4	160	100	600	700	800	900	1000	1100	1200	1300
	160	160	960	1120	1280	1440	1600	1760	1920	2080
	250	200	1200	1400	1600	1800	2000	2200	2400	2600
S5	400	320	1920	2240	2560	2880	3200	3520	3840	4160
S6	800	630	3780	4410	5040	5670	6300	6930	7560	8190
S7	1250	1000	6000	7000	8000	9000	10000	11000	12000	13000
S4X	250	100	600	700	800	900	1000	1100	1200	1300
	250	160	960	1120	1280	1440	1600	1760	1920	2080
	250	200	1200	1400	1600	1800	2000	2200	2400	2600
S6X	400	320	1920	2240	2560	2880	3200	3520	3840	4160
	630	400	2400	2800	3200	3600	4000	4400	4800	5200
	630	630	3780	4410	5040	5670	6300	6930	7560	8190

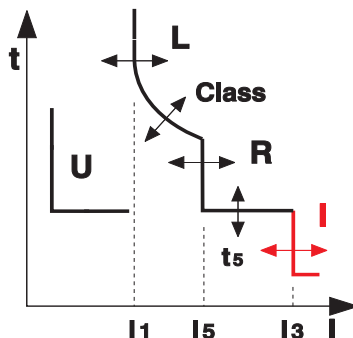
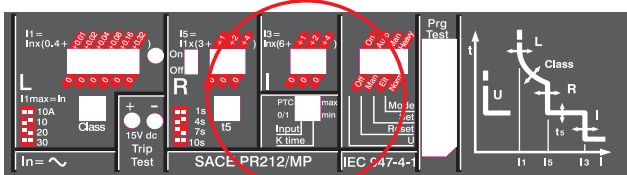

S6-S7

E

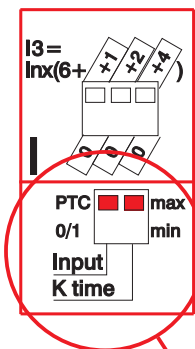

Input	PTC	<p>Connesso a sonda PTC mod. Siemens/Matsushita B59355-M130-A70 o equivalente. Lunghezza massima del collegamento 50 mt.</p> <p>Connected with temperature dependent resistor (PTC) type Siemens/Matsushita B59355-M130-A70 or similar. Max connection length = 50 mt.</p>
	0/1	<p>Connesso a contatto NO o NC senza potenziale. Lunghezza max collegamento 50 mt.</p> <p>Connected with NO or NC contact without voltage. Max connection length = 50 mt.</p>

Input: senza PTC settare 0/1
Input: without PTC set 0/1

K time	Tempo di apertura contattore	max	~ 160 ms
	Contactor tripping time	min	~ 80 ms

F

S4-S5

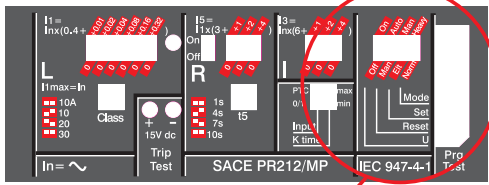

	Iu(A)	In(A)	I6(A) on= 0,4
S4	160	100	40
	160	160	64
	250	200	80
S5	400	320	128
S6	800	630	252
S7	1250	1000	400
S4X	250	100	40
	250	160	64
	250	200	80
S6X	400	320	128
	630	400	160
	630	630	252

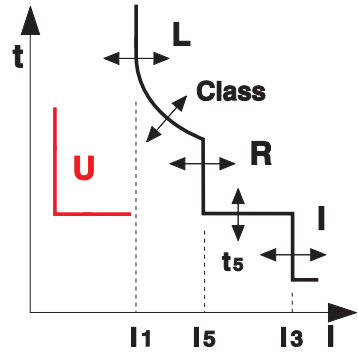
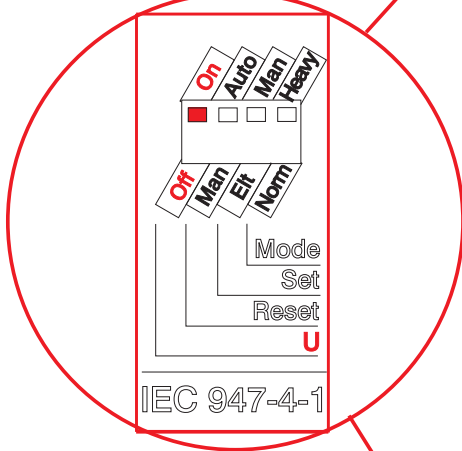

S6-S7

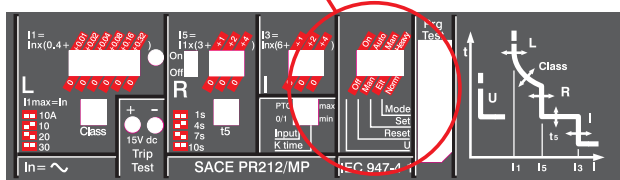

G

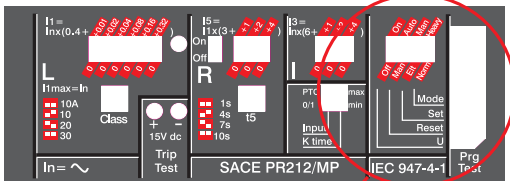

Mode	Heavy	Solo Interruttore Circuit Breaker Only
	Norm	Interruttore + Contattore Circuit Breaker + Contactor

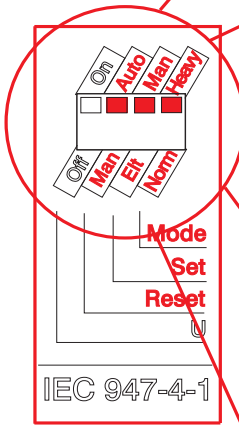

Set	Man	Settaggio tramite dip-switch (vedi par.B) Setting by dip-switch (see par.B)
	Eit	Settaggio tramite sist. di comunicazione (vedi par.L) Setting by communication system (see par.L)

Reset	Auto	Reset automatico del PR212/CI (Normal) dopo 15 s PR212/CI automatic reset (Normal) after 15 s
	Man	Reset manuale del PR212/CI (Normal) a cura del cliente. PR212/CI manual reset (Normal) by customer.

H

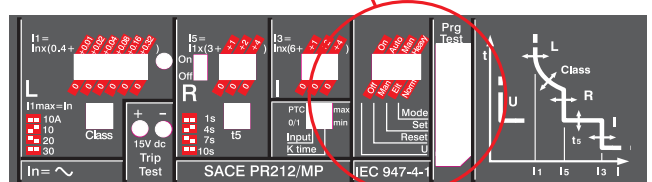

TRIPTEST

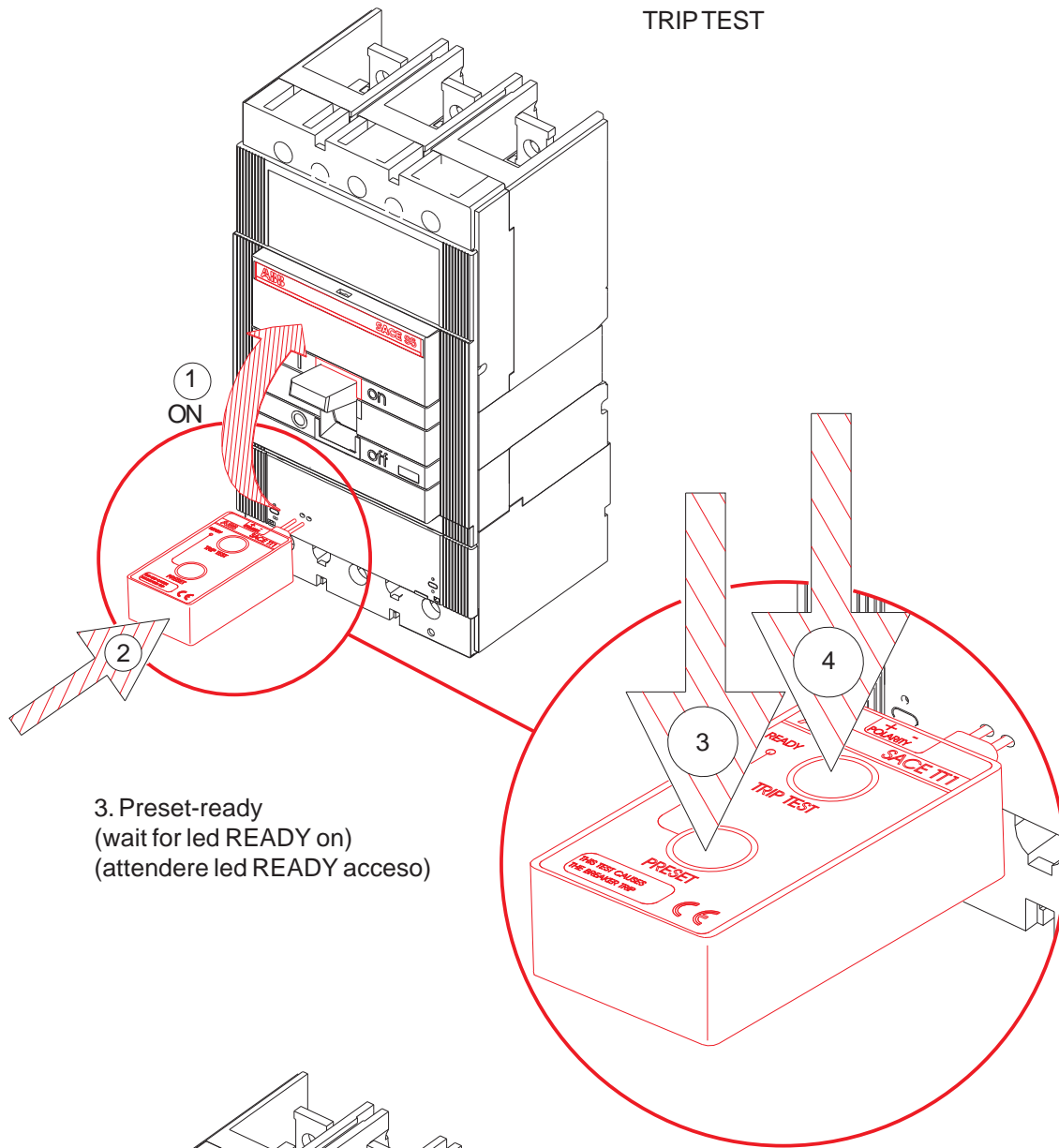

3. Preset-ready
(wait for led READY on)
(attendere led READY acceso)

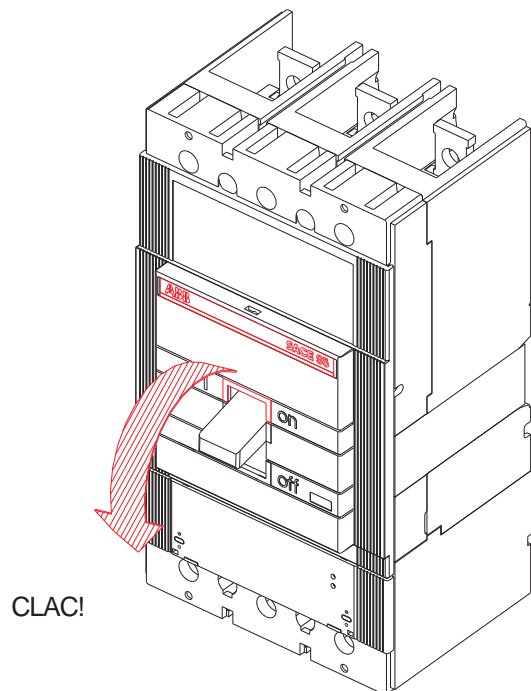

Settaggio di default elettronico
Electronic default set

S3-S4

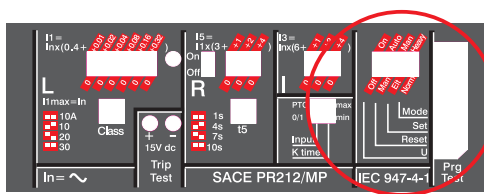

S6-S7

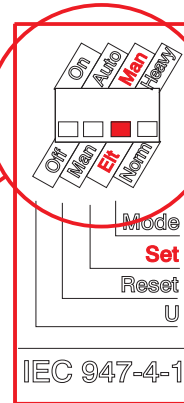
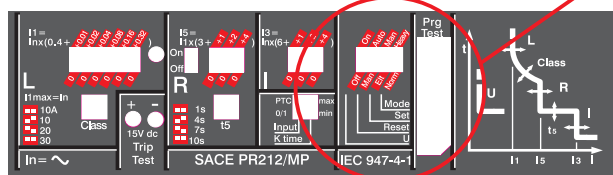

L	1xIn - 10A
R	Off
I	13xIn
U	Off
Input	0/1
Mode	Heavy
Ktime	Min

Valori parametri elettronici
Electronic parameters value

Protection	Name	Range	Step for electronic set
L Sovraccarico/Overload	I1	0,4 ... 1,0 x In	0,01 x In
	t1	4,0 ... 24,0 s	1 s
R Rotore bloccato/Locked rotor	I5	3.0 ... 10 x I1+Off	0.1 x I1 + Off
	t5	1 ... 10 s	0,5 s
I Corto circuito/Short circuit	I3	6.0 ... 13 x In	0.1 x In
	t3	-	-
U Sbilanciamento/Unbalance	I6	0.4 + Off	On + Off
	t6	4s	-

L

Note/Notes

- X3-6 e X4-4 sono riservati alla segnalazione "Contatti incollati" proveniente da specifici contattori ABB.
- X3-6 and X4 -4 are reserved for specific ABB contactors "Welded contacts" signalling.
- Per tutte le connessioni con cavo schermato utilizzare il tipo secondo T54602 ABB SACE, provvedendo a connettere lo schermo a terra in prossimità del dispositivo/ accessorio esterno.
- For shielded connection use T54602 ABB SACE cable. The shield must be connected to ground near external devices.

M

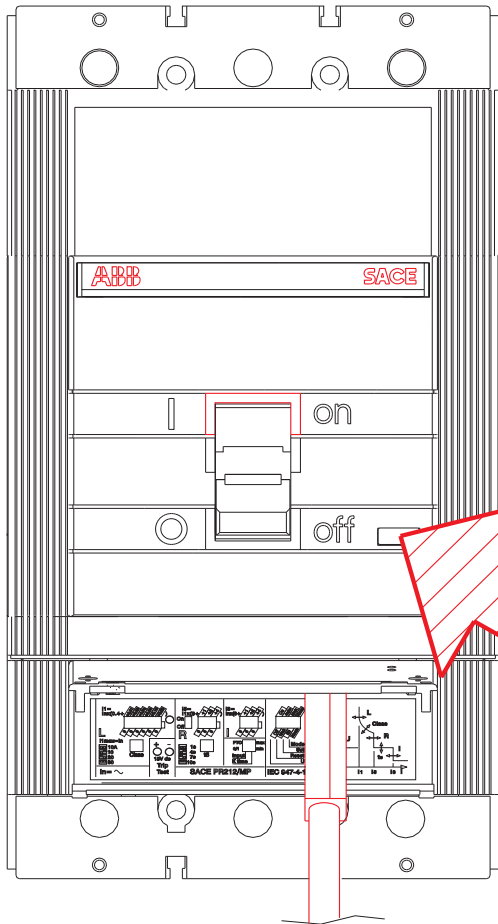

Programmazione e Test con Unità PR010/T
 Programming and test with PR010/T

1. Posizione leva TRIP oppure OFF per test con PR010/T
1. CB Position TRIP or OFF for test with PR010/T

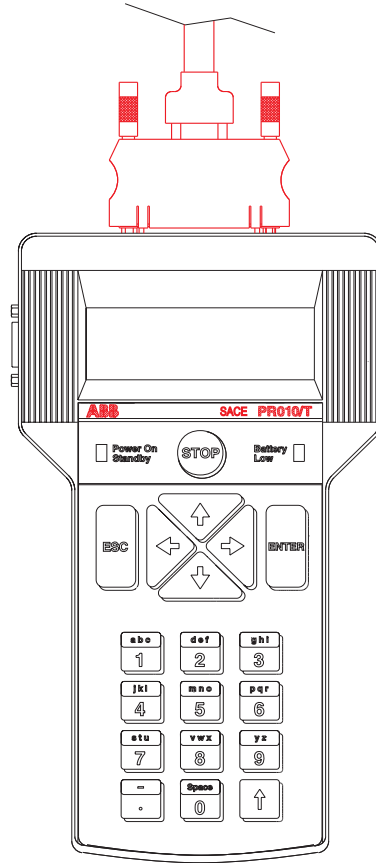

N