

TECHNICAL CATALOGUE

# SACE Emax 2 MS/DC-E

Air Switch-disconnectors at 1500V DC



---

**The SACE Emax 2 MS/DC-E range of air switch-disconnectors offers an increasingly comprehensive, leading-edge solution that anticipates the market trends.**

**SACE Emax 2 MS/DC-E**  
Index

INTRODUCTION

01

RANGE

02

INSTALLATION

03

DIMENSIONS  
AND WIRING

04

ORDERING CODES

05



---

# Introduction

- 1/2**      **Keeping ahead of the DC application trends**
- 1/3**      **Value proposition**
- 1/4**      **Application examples**

---

# Keeping ahead of the DC application trends

The SACE Emax 2 MS/DC-E air switch-disconnectors further expand SACE's broad offering of low voltage devices providing a solution to all our customer's applications. Meeting both IEC and UL standards, this new range was designed with internationalization in mind. It offers to design engineers, panel builders and OEM manufacturers the chance to rely on a single provider and meet the specific requirements of a wide range of DC applications installed in any part of the world. A range that keeps pace with the times.

String inverter configurations and higher operating voltages are the current trend in photovoltaic systems. System designers and their customers want to enhance energy efficiency and limit the rated currents thereby reducing switchgear size, installation time, and associated costs.



---

Quality, innovation and the ability to keep up with technological developments while satisfying the every changing needs of our customers: these, in short, are the key strengths of the SACE Emax 2 MS/DC-E range of switch disconnectors.

By 2021, according to ABB estimates, over 93% of PV systems above one megawatt will function with 1500V DC rated voltage, even more so in areas where UL regulations are applicable. This will increase the power density and significantly reduce the number of combiners, inverters and conductors required compared to 1000V DC systems.

---

# Value proposition

## Innovations technologies to be a step ahead



---

### Global availability

Ensuring performances at 1500V DC under IEC and UL standards, SACE Emax 2 MS/DC-E range provide a unique solution for any projects around the world. Any version up to 3200A can also be ordered with IEC & UL & CCC approvals. This means that engineers, panel builders, inverter manufacturers and OEMs can find the right solution for any plant installed anywhere in the world.



---

### Flexible installation

The SACE Emax 2 MS/DC-E range of air switch-disconnectors guarantee great flexibility for any installation. It is possible to insulate one polarity or both, and manage current flow in both directions.

In addition, it is available in fixed and drawable version, and terminals can be setup vertically or horizontally.

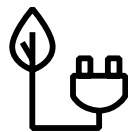

---

### Energy efficiency

The SACE Emax 2 MS/DC-E range is here to support the energy efficiency trend in Energy Storage and Photovoltaic systems. Achieving 1500V DC helps to cut power losses and make our planet a better place.

# Application examples

## Energy Storage System plant

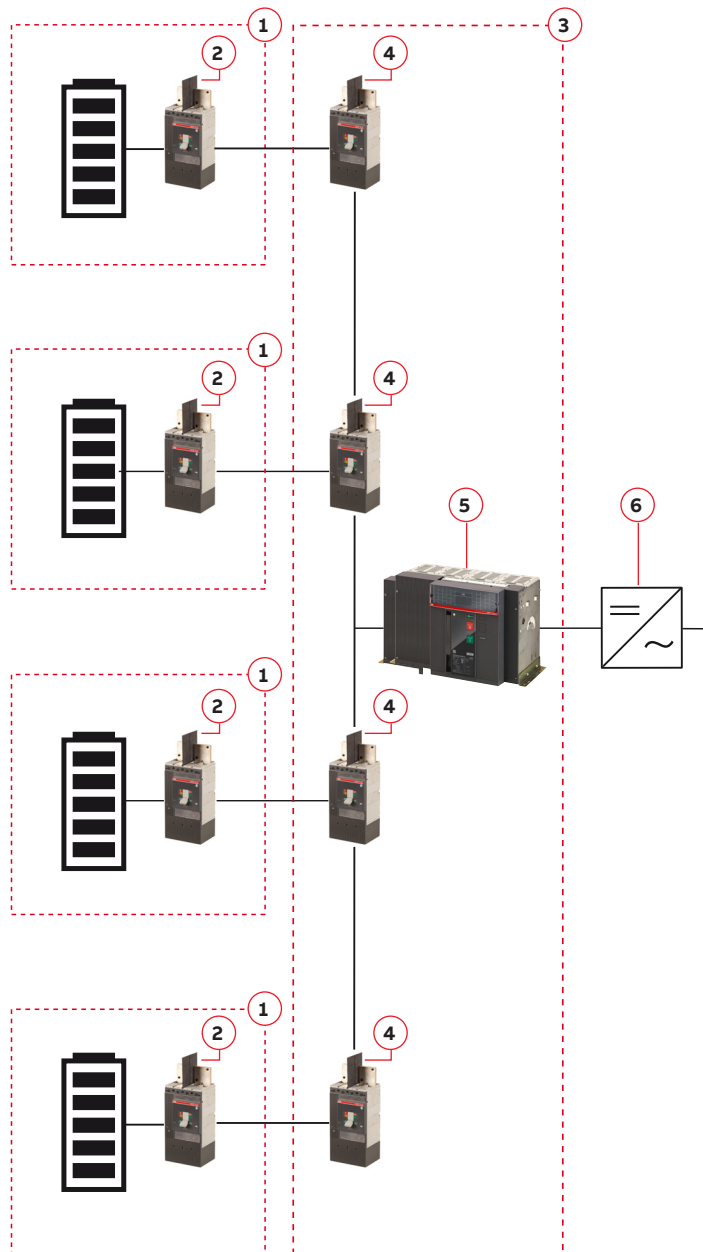

1. Battery module
2. Molded Case Switch-Disconnecter Tmax PV
3. ESS combiner
4. Molded Case Circuit-Breakers Tmax PV
5. Air Switch-Disconnecter Emax 2 MS/DC-E
6. Inverter

# Application examples

## Photovoltaic plant

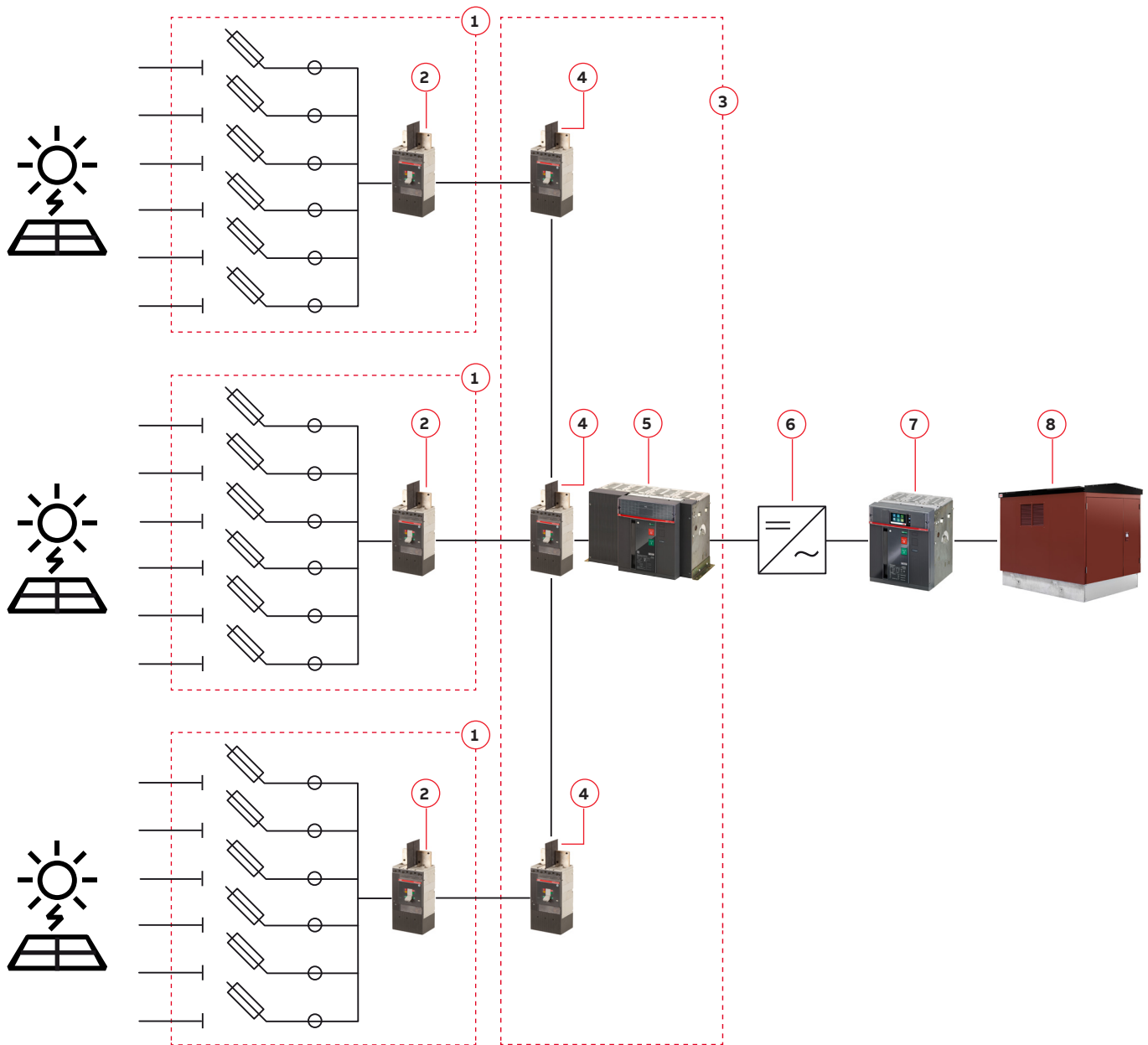

1. String Combiner
2. Molded Case Switch-Disconnecter Tmax PV
3. Recombiner
4. Molded Case Circuit-Breakers Tmax PV
5. Air Switch-Disconnecter Emax 2 MS/DC-E
6. Central inverter
7. Air Circuit-Breaker Emax 2
8. MV/LV Transformer - Compact Secondary Substation



---

# Range

- 2/2** IEC range
- 2/5** UL range
- 2/7** Global version
- 2/8** Accessories

# Flexibility guaranteed for IEC compliant requirements

In accordance with IEC60947-3 Annex D specifications, the SACE Emax 2 MS/DC-E air switch-disconnectors offer a broad range of extended ratings for today's increasingly demanding DC applications.

Connection jumpers are available factory mounted or field mountable for enhanced safety and installation flexibility.

The SACE Emax 2 MS/DC-E IEC range has been developed for installations up to 1500V DC and 4000 A, with short-time withstand current up to 100 kA.

The SACE Emax 2 MS/DC-E is compliant with DC-PV2, the most demanding Utilization Category according to IEC 60947-3 Annex D, since it requires the ability to connect and disconnect PV circuits where significant overcurrents may occur and where current flow can be in either direction; these are common characteristics of centralized PV systems.

Because of dedicated shorting busbar (jumper) kits, all four poles can be connected in series to isolate a single polarity source, or alternatively for a dual polarity source 2 poles can be configured in series for the positive supply and the other 2 poles in series for the negative supply.

The SACE Emax 2 MS/DC-E DC-20 is the new 6000 A disconnector based on the E4.2 MS/DC-E certified according to IEC 60947-3 (DC-20 utilization category) to guarantee isolation up to 1500V DC. Parallel links between poles are provided as internal, factory mounted feature.

SACE Emax 2 MS/DC-E can be fitted with a vast assortment of electrical and mechanical accessories already available for the standard SACE Emax 2 range. The IEC version has also achieved China CCC certification.



# IEC Range

Common data		
Rated service voltage Ue	[V]	1500
Rated insulation voltage Ui	[V]	1500
Rated impulse withstand voltage Uimp	[kV]	12
Number of poles		4
Version		Fixed - Withdrawable
Suitable for isolation according to		IEC 60947-3
Utilization category		DC22A, DC-PV2 (Annex D)



SACE Emax2 MS/DC-E for IEC			E4.2		
Performance levels			S	H	V
Rated uninterrupted current I <sub>u</sub> @ 40°C		[A]	1600	1600	1600
		[A]	2000	2000	2000
		[A]	2500	2500	2500
		[A]	3200	3200	3200
		[A]	4000	4000	4000
Rated short-time withstand current I <sub>cw</sub>	(1s)	[kA]	65	85	100
Rated short-circuit making capacity (peak value) I <sub>cm</sub>	1500 V	[kA]	65	85	100
Dimensions	H - Fixed	[mm]	371		
	D - Fixed		270		
	W - Fixed 4p		510		
	H - Draw out	[mm]	425		
	D - Draw out	[mm]	393		
	W - Draw out 4p	[mm]	551		

SACE Emax2 MS/DC-E for IEC 60947-3		E4.2				
	[I <sub>u</sub> ]	1600	≤2000	≤2500	≤3200	≤4000
Mechanical life*	[No. cycles x1000]	15	15	15	15	15
	Frequency [Oper./Hour]	20	20	20	10	10
Electrical life	[No. cycles x1000] tau=2 ms	10	8	5	3	2
	[No. cycles x1000] tau=7.5ms	5	4	2,5	1,5	1
	Frequency [Oper./Hour]	20	20	20	10	10

(\*) with regular ordinary maintenance prescribed by the manufacturer

# IEC Range

The SACE Emax 2 MS/DC-E DC-20 is the new 6000 A disconnecter based on the E4.2 MS/DC-E switch-disconnector, certified according to IEC 60947-3 (DC-20 utilization category) to guarantee isolation up to 1500VDC.

Common data	
Rated service voltage Ue	[V] 1500
Rated insulation voltage Ui	[V] 1500
Rated impulse withstand voltage Uimp	[kV] 12
Number of poles	4
Version	Withdrawable
Suitable for isolation according to	IEC 60947-3
Utilization category	DC-20A



SACE Emax2 MS/DC-E DC-20		E4.2	
Performance levels		V	
Rated uninterrupted current Iu @ 40°C		[A]	6000
Rated short-time withstand current Icw (1s)		[kA]	100
Dimensions	H – Draw out	[mm]	425
	D – Draw out	[mm]	393
	W – Draw out 4p	[mm]	551
Mechanical Life <sup>(1)</sup>		[No. cycles x 1000]	15
	Frequency	[Oper./ Hour]	60

<sup>(1)</sup> With regular maintenance prescribed by the manufacturer

Note: DC-20 utilization category means “Do not operate under load”: opening and closing of breaker must be performed only when current is equal to zero.

According to IEC standard, the use of DC-20 utilization categories is not permitted in the USA.

For CCC approval, contact ABB.

# Dedicated solutions compliant with UL Standards

The SACE Emax 2 MS/DC-E UL range includes a full assortment of air switch-disconnectors compliant with UL489B and UL489F standards. Multiple versions that form a complete portfolio of shared accessories, including factory mounted connection jumpers that are mandatory for SACE Emax 2 MS/DC-E UL. Jumpers ensure ease of installation, safety, and are fully compliant with UL regulations.

The SACE Emax 2 MS/DC-E range of switch-disconnectors covers 1500V DC installations in compliance with UL489B (for use with Photovoltaic systems) and UL489F (for use with Battery Power Supplies), with rated short-time current up to 100kA.

Sharing the same dimension as the standard Emax 2, these compact switch-disconnectors allow UL switchgear and inverters manufacturers to optimize their footprint.

Thanks to the factory-fitted shorting busbar (jumper) kits, all four poles can be connected in series to isolate a single polarity source, or alternatively for a dual polarity source 2 poles can be configured in series for the positive supply and the other 2 poles in series for the negative supply.

All products can be equipped with the most common UL listed mechanical and electrical accessories already available for the SACE Emax 2 air circuit-breaker range.



# UL Range

Common data		
Rated maximum voltage	[V]	1500
Rated voltage	[V]	1500
Number of poles		4
Version		Fixed - Withdrawable
UL file		E348799, E501222



SACE Emax2 MS/DC-E for UL			E4.2		
Performance levels			S-A	H-A	V-A
Rated current	UL489B, UL489F	[A]	1600	1600	1600
	UL489B, UL489F	[A]	2000	2000	2000
	UL489B, UL489F	[A]	2500	2500	2500
	UL489B	[A]	3200	3200	3200
Rated short-time current	(1s)	[kA]	65	85	100
Dimensions	H - Fixed	[in / mm]	14.61/371		
	D - Fixed	[in / mm]	10.63/270		
	W - Fixed (4p)	[in / mm]	20.08/510		
	H - Draw out	[in / mm]	16.73/425		
	D - Draw out	[in / mm]	15.47/393		
	W - Draw out (4p)	[in / mm]	21.69/551		

SACE Emax2 MS/DC-E for UL 489B & 489F		E4.2			
	[Iu]	1600	≤2000	≤2500	≤3200
Mechanical life*	[No. cycles x1000]	15	15	15	15
	Frequency [Oper./Hour]	20	20	20	10
Electrical life	[No. cycles x1000] tau=2 ms	10	8	7	3
	Frequency [Oper./Hour]	60	60	60	60 (**)

(\*) with regular ordinary maintenance prescribed by the manufacturer

(\*\*) see note of table 7.1.5.1 UL 489

# Global multi-standard version IEC, UL and CCC compliant

The SACE Emax 2 DC range includes a global multi-standard version compliant with IEC 60947-3, UL 489B, UL489F and with CCC approval.

The SACE Emax 2 MS/DC-E range of switch-disconnectors in multi-standard version covers 1500V DC installations with the following rated currents:

- 1600, 2000 and 2500 A: IEC 60947-3, UL 489B, UL489F and GB/T 14048.3 (CCC approval).
- 3200 A: IEC 60947-3, UL 489B, and GB/T 14048.3 (CCC approval).

Thanks to the factory-fitted shorting busbar (jumper) kits, all four poles can be connected in series to isolate a single polarity or alternatively for a dual polarity source.

All products can be equipped with the most common UL listed mechanical and electrical accessories already available for the SACE Emax 2 air circuit-breaker range.

For technical data, please refer to the UL versions of SACE Emax 2 MS/DC-E range.



# Accessories

SACE Emax 2 MS/DC-E switch-disconnectors offer a wide range of accessories already available for SACE Emax 2 air circuit-breaker, developed to satisfy the application and installation requirements of every customer.

	E4.2
<b>Signalling</b>	
Standard open/closed auxiliary contacts - AUX 4Q	○ / ∞
Open/closed auxiliary contacts - AUX 6Q	○ / ∞
Open/closed auxiliary contacts- AUX 15Q	○ / △
Auxiliary position contacts - AUP	△
Ready to close signalling contact - RTC	○ / ∞
Contact signalling loaded springs – S33 M/2 (supplied with Motor)	○ / ∞
<b>Control</b>	
Opening and closing release - YO/YC	○ / ∞
Second opening and closing release - YO2/YC2	○ / ∞
Undervoltage release - YU	○ / ∞**
Electronic time-delay device for undervoltage release - UVD	○ / ∞
Motor - M	○ / ∞
Remote reset - YR	-
Opening and closing release test unit - YO/YC Test Unit	○ / △
<b>Safety</b>	
Key lock and padlock in open position - KLC and PLC	○ / ∞
Key lock and padlock in racked-in / test / racked-out position - KLP and PLP	∞
Shutter lock - SL	▲
Lock for racking-out mechanism with circuit-breaker in closed position	●●
Lock for racking in / racking out the mobile part when the door is open - DLR	△
Lock to prevent door opening when circuit-breaker is in racked-in / test position - DLP	△
Lock to prevent door opening when circuit-breaker is in closed position - DLC	○ / ∞
Anti-insertion lock	● / ●●
Mechanical operation counter - MOC	○ / ∞
<b>Protection devices</b>	
Protection device for opening and closing pushbuttons - PBC	○ / ∞***
IP30 Protection	● / ▲
IP54 Protection	○ / △
Terminal covers - HTC / LTC	-
<b>Connections</b>	
Orientable rear terminal - HR/VR	● / ▲*
<b>Interlocks and switching devices</b>	
Mechanical interlock - MI	○ / ∞ / △
<b>Fail Safe</b>	
● Standard accessory for fixed circuit-breaker	○ Accessory on request for fixed circuit-breaker
○ Accessory on request for fixed circuit-breaker	●● Standard accessory for mobile part
●● Standard accessory for mobile part	∞ Accessory on request for mobile part
	▲ Standard accessory for fixed part
	△ Accessory on request for fixed part
	(*) UL 2500/3200A vertical only
	(**) For DC-20 undervoltage release (YU) cannot be provided
	(***) For DC-20 PBC is a standard accessory

## Note:

For more information about accessories, installation and ordering codes consult SACE Emax 2 general catalogue



IEC version: 1SDC200023D0209



UL version: 1SXU200040C0201

---

# Installation

- 3/2**      **Breaker**
- 3/2**      Versions and connections
- 3/2**      Degree of protection
- 3/2**      Power losses
- 3/2**      Altitude
  
- 3/3**      **Installation environment**
- 3/3**      Temperature derating
- 3/3**      Temperature
- 3/3**      Environment conditions
- 3/3**      Electromagnetic compatibility
  
- 3/4**      **Installation in switchgear**
- 3/4**      Position
- 3/4**      Insulation distances and connection
- 3/5**      Busbar types

# Breaker

## Versions and connections

The SACE Emax 2 MS/DC-E switch-disconnector is based on 4 poles version of Emax 2 frame E4.2 and it is available in fixed or withdrawable versions, except for the DC-20 which is available only in withdrawable version.

All SACE Emax 2 MS/DC-E is used with all poles connected in series, for this reason specific connection busbars (also called “jumpers”) are mounted on breaker terminals.

It is possible to select the interruption of one polarity of DC network or both, and the breaker side of power supply and load can be from the lower or upper terminals.

In most cases it is possible to select between vertical and horizontal terminals:

Iu	IEC		UL	
	VR	HR	VR	HR
1600	●	●	●	●
2000	●	●	●	●
2500	●	●	●	-
3200	●	●	●	-
4000	●	●	-	-

## Degree of protection

SACE Emax 2 circuit breakers guarantee the following degrees of protection:

- IP20 for circuit breakers in fixed or drawout versions, excluding the terminals.
- IP30 for the front parts of the circuit breaker when installed in switchgear with the IP30 flange mounted on the door.
- IP54 for circuit breakers equipped with optional IP54 transparent flange fixed on the door on the front of the switchgear.

## Power losses

The values given in the table refer to total power for four pole circuit breakers with a current flow equal to rated uninterrupted current.

	[W]/[A]	1600	2000	2500	3200	4000	5000	6000
Fixed	W	130	200	320	500	620	-	-
Drawout	W	230	360	560	800	1200	-	-
DC-20 Drawout	W	46	71	111	182	285	445	641

## Altitude

SACE Emax 2 air circuit breakers guarantee rated performance up to 2000 meters above sea level.

Beyond this altitude, the performance of the circuit breakers is subject to derating, which can be measured by means of the variation in maximum rated service voltage and rated uninterrupted current.

Altitude	[m]	2000	3000	4000	5000
	[ft]	6600	9900	13200	16500
Rated service voltage - Ue	[V]	1500	1320	1170	1022
Rated current	[%In]	100	98	93	90

# Installation environment

## Temperature derating

Under certain installation conditions, circuit breakers can operate at higher temperatures than the reference temperature of 40 °C. In this case the current-carrying capacity of the circuit-breaker may be lower than the rated current-carrying capacity at the reference temperature: therefore the derating coefficients shown in the table must be applied. Percentage values refer to withdrawable and fixed circuit breaker. If not specified, all data refer to a copper.

Emax 2 E4.2 IEC	Temperature [°C/°F]							
	lu	<40/104	45/113	50/122	55/131	60/140	65/149	70/158
1600		100%	100%	100%	100%	100%	100%	100%
2000		100%	100%	100%	100%	100%	100%	100%
2500		100%	100%	100%	100%	95%	90%	85%
3200		100%	100%	100%	100%	100%	100%	100%
4000		100%	100%	100%	100%	95%	90%	85%
6000		100%	100%	95%	90%	86%	83%	80%

Emax 2 E4.2 UL	Temperature [°C/°F]							
	lu	<40/104	45/113	50/122	55/131	60/140	65/149	70/158
1600		100%	100%	100%	100%	100%	100%	100%
2000		100%	100%	100%	100%	95%	90%	85%
2500		100%	100%	100%	100%	100%	100%	100%
3200		100%	100%	100%	100%	95%	90%	85%

The installation requirements prescribed by the international Standards are listed below.

## Temperature

SACE Emax 2 circuit breakers can operate in the following environmental conditions:

	Temperature	
	Operating	Storage
Emax 2 switch-disconnector	-25°C...+70°C -13°F...+158°F	-40°C...+70°C -40°F...+158°F

## Environmental conditions

The devices can be installed in industrial environments with pollution level 3, IEC60947.

SACE Emax 2 circuit breakers also comply with:

- IEC60721-3-6 class 6C3
- IEC60721-3-3 class 3C2

## Electromagnetic compatibility

The use of specific devices in industrial installations may cause electromagnetic interference in the electrical system. SACE Emax 2 MS/DC-E switch-disconnectors have been developed and tested for electromagnetic compatibility in accordance with 60947-3.

# Installation in switchgear

## Position

All SACE Emax 2 circuit breakers can be floor mounted in a vertical position inside the switchgear compartment.

## Insulation distances and connection

The circuit breakers can be connected to the main power system using the most common configurations and dimensions of copper bars.

Installation of live parts must ensure minimum insulation distances between the phases.

### • Insulation distance of installation cubicle:

E4.2	Fixed			Drawout		
	Width	Heigh	Depth	Width	Heigh	Depth
[mm]	800 <sup>(1)</sup>	600 <sup>(2)</sup>	221	800 <sup>(1)</sup>	440	355
[inch]	31.50 <sup>(1)</sup>	23.62 <sup>(2)</sup>	8.7	31.50 <sup>(1)</sup>	17.32	13.97

(1) Cubicle width can be reduced to 600 mm (23.62 inch) when lateral walls are insulated.

(2) Cubicle height for Fixed version can be reduced to 500 mm (19.69 inch) when roof panel is insulated.

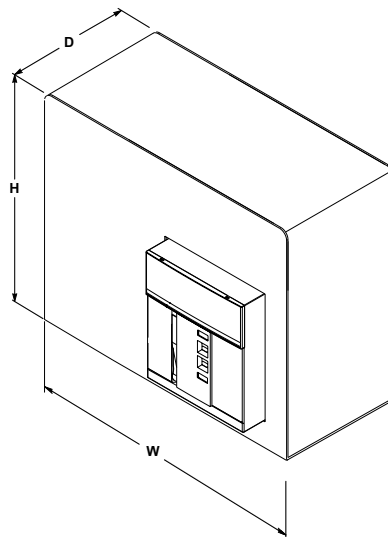

### • Separator PB and insulation frame

The rear part of the circuit breaker has been designed with specific slots in which insulating walls are placed to facilitate segregation between polarities.

Fixed versions also have additional phase separator for top side of breaker. (see document [1SDH001000R0746](#)). All those insulations are mandatory for following configurations of Emax 2 MS/DC-E: 2 poles in series for each polarity (network configurations A and B, page 5/3).

### • Tightening torques

Connections	E4.2
Busbars to terminals	70 Nm / 619.55 lb-in
Jumpers to terminals	70 Nm / 619.55 lb-in
Terminals to breaker	20 Nm / 177.01 lb-in

## Busbar types

The circuit breakers, via the terminals, can be connected to the main distribution system by busbars of different types: copper, silver-plated copper and tinned aluminum when the main distribution system is made of aluminum.

### Bars recommendation

#### IEC version:

Iu	Qty	Vertical	Horizontal
		Size (mm)	Size (mm)
1600	2	100 x 5	100 x 5
2000	2	100 x 8	100 x 8
2500	2	100 x 10	100 x 10
3200	3	100 x 10	100 x 10
4000	4	100 x 10	100 x 10
6000	6	100 x 10	100 x 10

#### UL version:

Iu	Qty	Vertical	Horizontal
		Size (in)	Size (in)
1600	2	1/4 x 3	1/4 x 3
2000	4	1/4 x 2	1/4 x 2.5
2500	3	1/4 x 4	-
3200	4	1/4 x 4	-
	5	1/4 x 3	-

The tables should be used solely as a general guideline for selecting products. Due to the extensive variety of switchgear construction shapes and conditions that can affect the behavior of the apparatus, the solution used must always be verified.





---

# Dimensions and wiring

- 4/2**      **IEC Fixed execution**
- 4/6**      **IEC Withdrawable execution**
- 4/11**     **UL Fixed execution**
- 4/15**     **UL Withdrawable execution**
- 4/19**     **Terminal box**
- 4/20**     **Electrical accessories**

# IEC Fixed execution

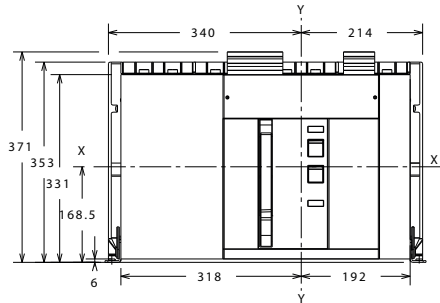

## Compartment door drilling

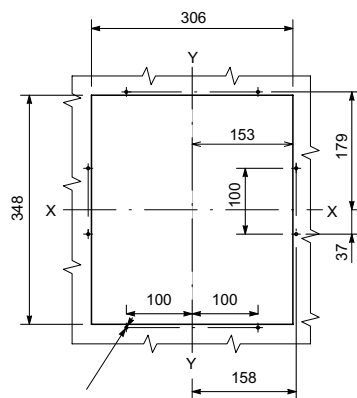

## Floor fixing

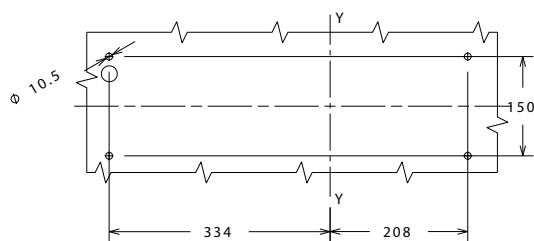

## Earthing device

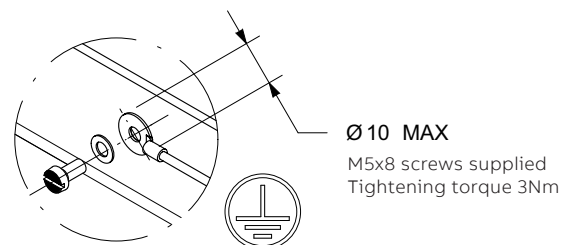

Orientable rear terminals - HR/VR

- Key  
1 Phase separator  
2 Insulated sheet

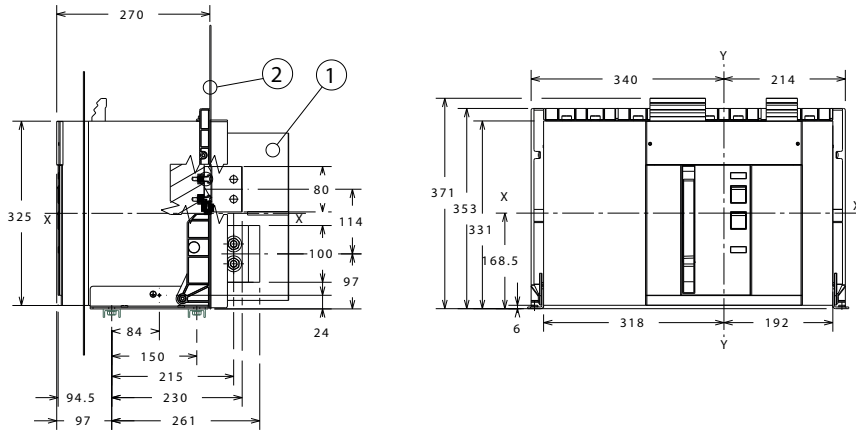

E4.2 1600-2000-2500A Terminals

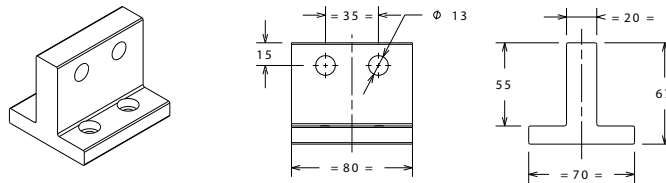

E4.2 3200-4000A Terminals

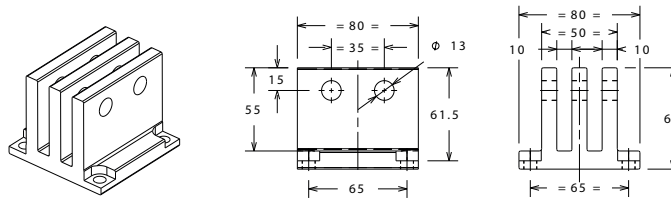

# IEC Fixed execution

## E4.2 1600-2000-2500A

### Configurations A & B

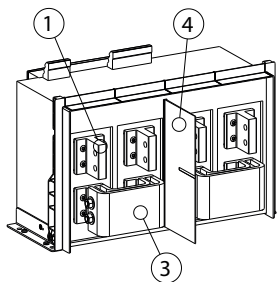

Upper supply VR

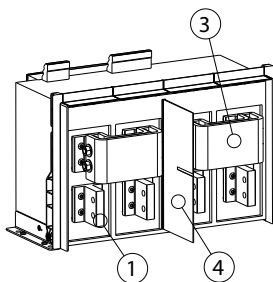

Lower supply VR

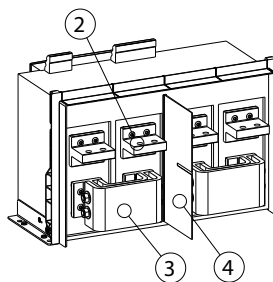

Upper supply HR

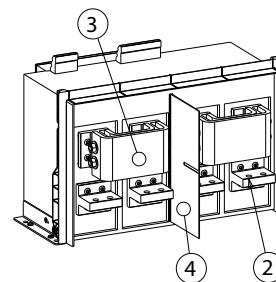

Lower supply HR

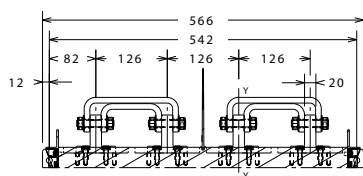

### Configurations C & D

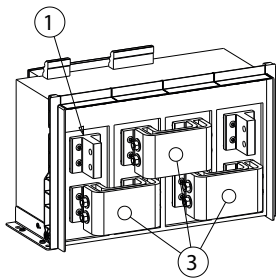

Upper supply VR

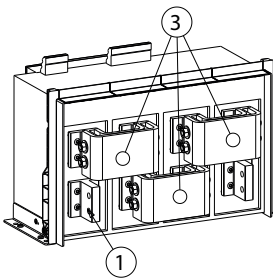

Lower supply VR

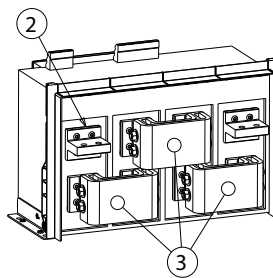

Upper supply HR

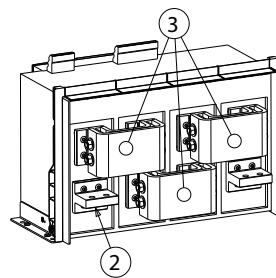

Lower supply HR

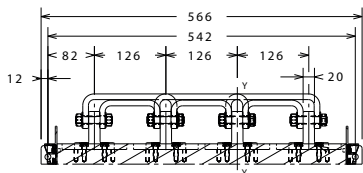

- Key
- 1 Vertical terminal  
1600-2000-2500A
  - 2 Horizontal terminal  
1600-2000-2500A
  - 3 Jumper 2C
  - 4 Phase separator

E4.2 3200-4000A

Configurations A & B

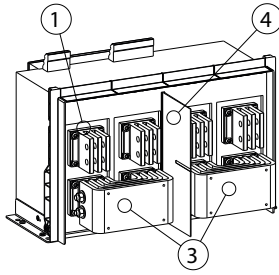

Upper supply VR

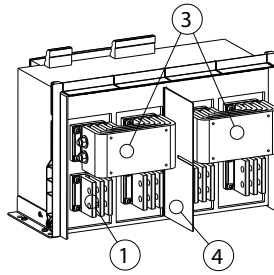

Lower supply VR

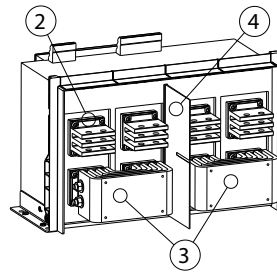

Upper supply HR

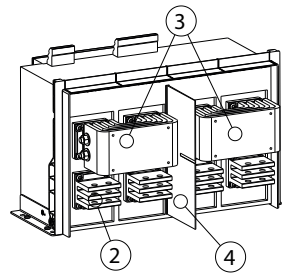

Lower supply HR

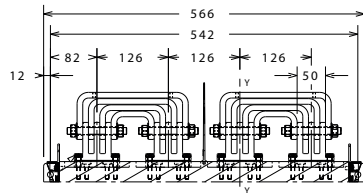

Configurations C & D

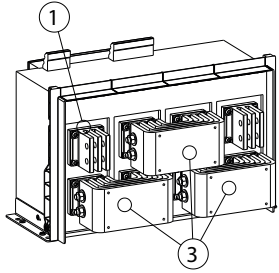

Upper supply VR

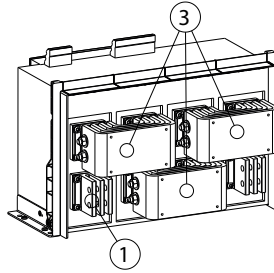

Lower supply VR

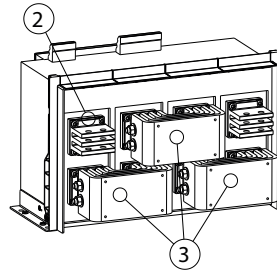

Upper supply HR

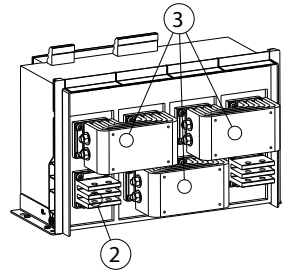

Lower supply HR

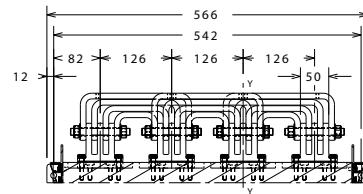

- Key
- Key
- 1 Vertical terminal 3200-4000A
  - 2 Horizontal terminal 3200-4000A
  - 3 Jumper 4C
  - 4 Phase separator

# IEC Withdrawable execution

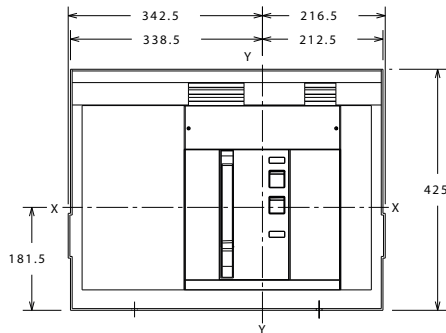

## Compartment door drilling

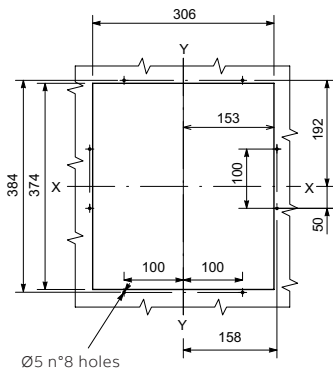

## Floor fixing

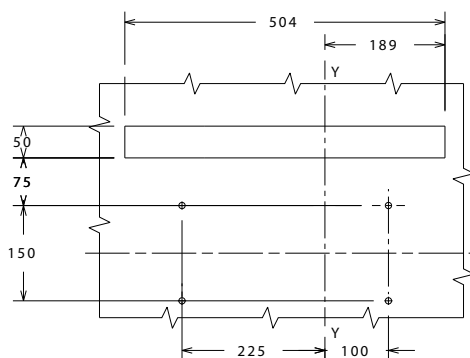

— Key  
1 Ventilation drilling on the switchgear

## Earthing device

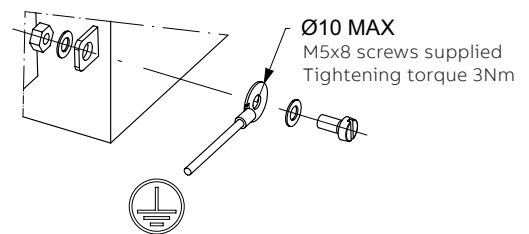



# IEC Withdrawable execution

## E4.2 1600-2000-2500A

### Configurations A & B

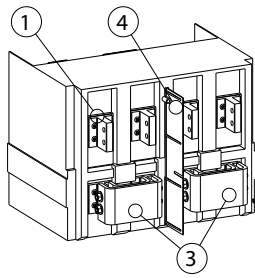

Upper supply VR

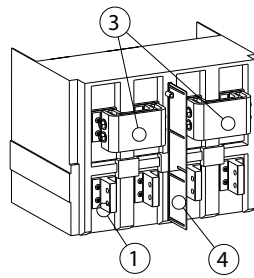

Lower supply VR

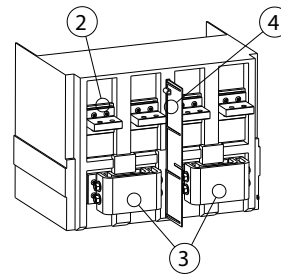

Upper supply HR

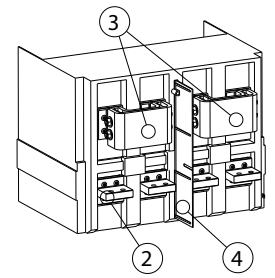

Lower supply HR

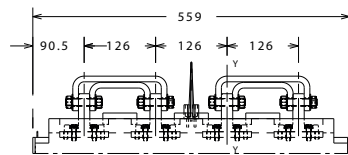

### Configurations C & D

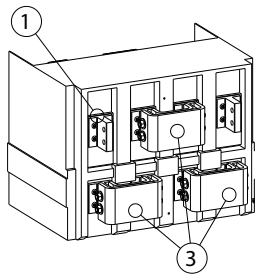

Upper supply VR

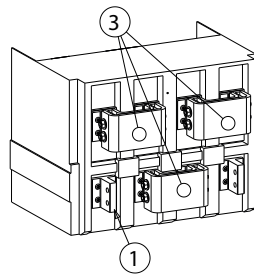

Lower supply VR

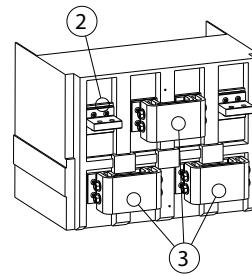

Upper supply HR

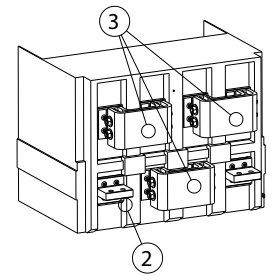

Lower supply HR

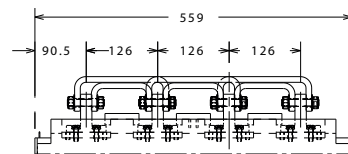

- Key
- 1 Vertical terminal  
1600-2000-2500A
  - 2 Horizontal terminal  
1600-2000-2500A
  - 3 Jumper 2C
  - 4 Phase separator

E4.2 3200-4000A

**Configurations A & B**

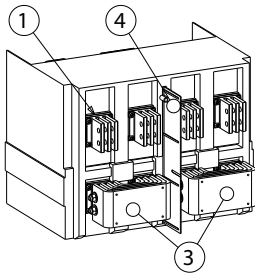

Upper supply VR

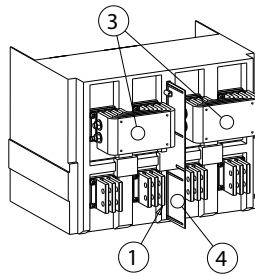

Lower supply VR

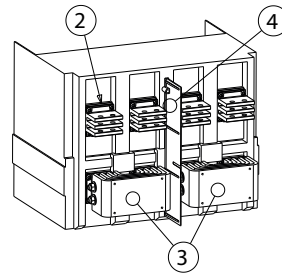

Upper supply HR

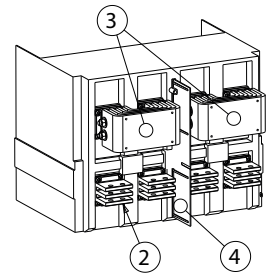

Lower supply HR

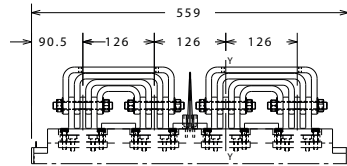

**Configurations C & D**

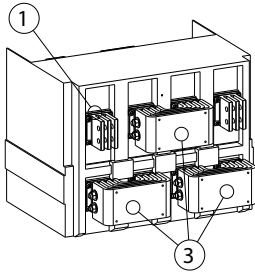

Upper supply VR

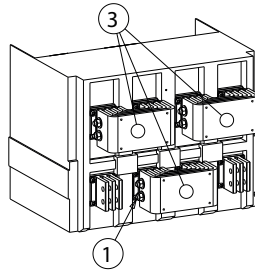

Lower supply VR

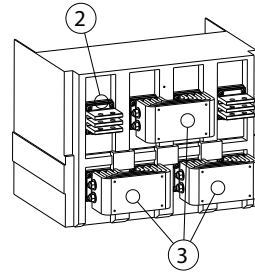

Upper supply HR

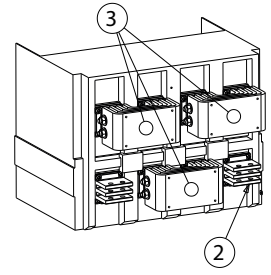

Lower supply HR

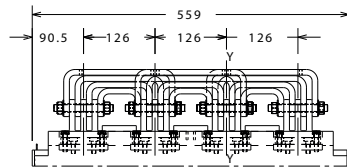

- Key
- 1 Vertical terminal 3200-4000A
  - 2 Horizontal terminal 3200-4000A
  - 3 Jumper 4C
  - 4 Phase separator

# IEC Withdrawable execution

E4.2 DC-20 4000A

- Key  
1 Vertical terminal  
2 Horizontal terminal  
3 Phase separator

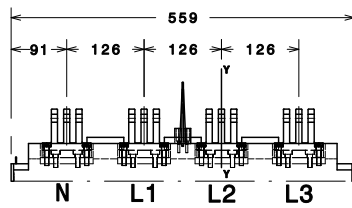
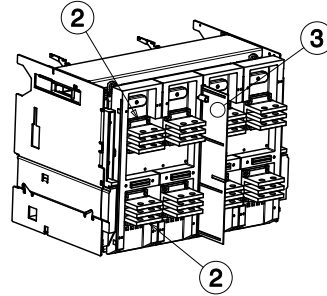
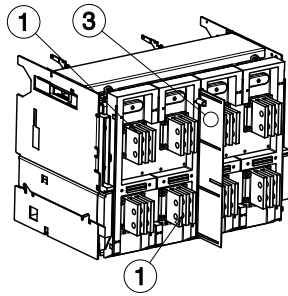

Vertical rear terminals

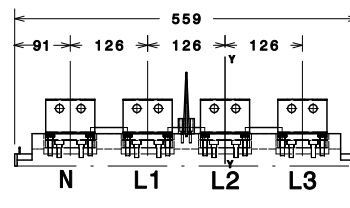

Horizontal rear terminals

# UL Fixed execution

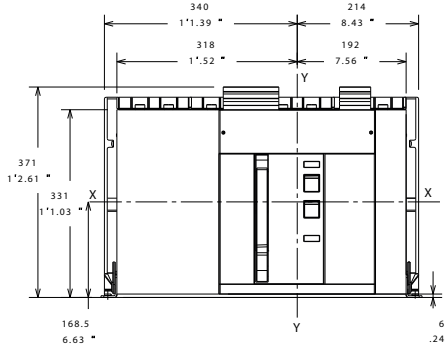

## Compartment door drilling

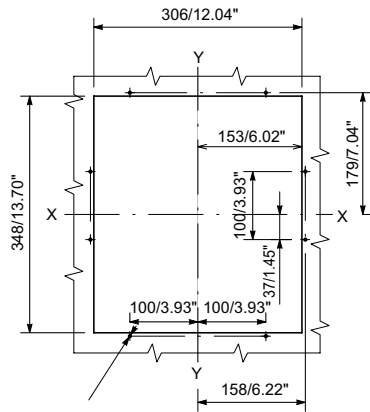

## Floor fixing

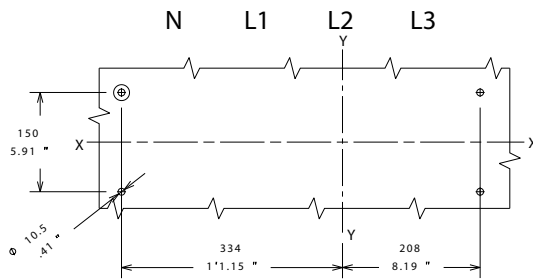

## Earthing device

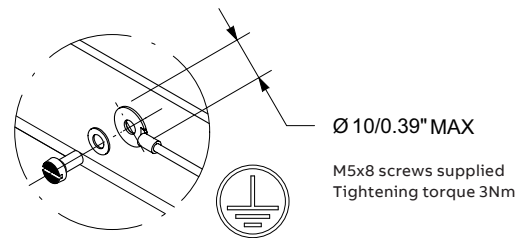

# UL Fixed execution

- Key  
 1 Phase separator  
 2 Insulation sheet

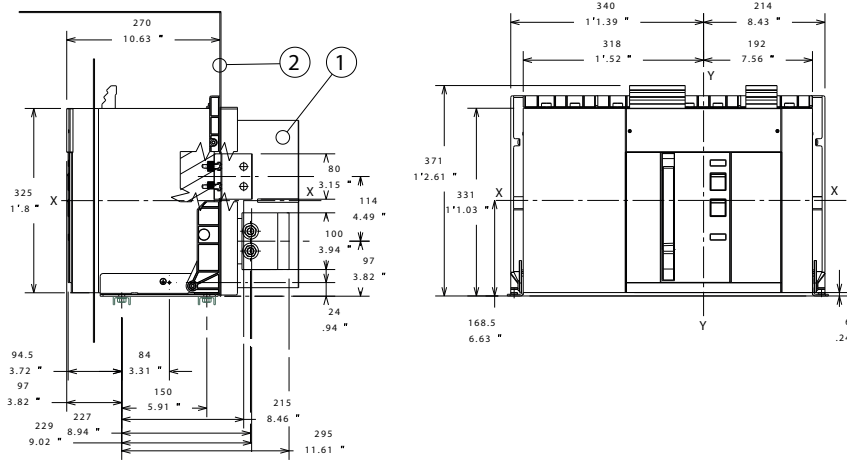

## E4.2 1600-2000A Terminals

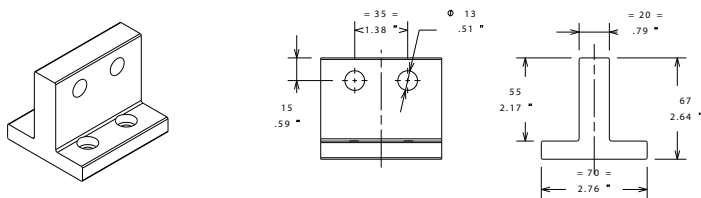

## E4.2 2500-3200A Terminals

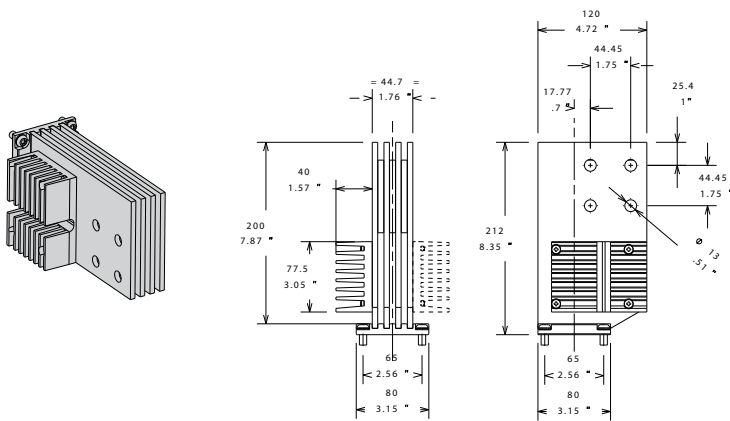

Orientable rear terminals - HR/VR  
E4.2 1600-2000A

**Configurations A & B**

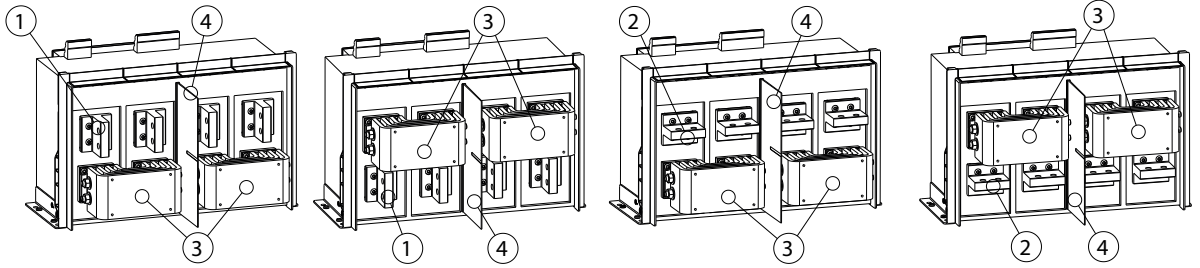

Upper supply VR

Lower supply VR

Upper supply HR

Lower supply HR

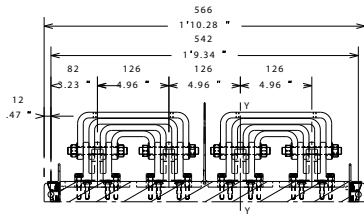

**Configurations C & D**

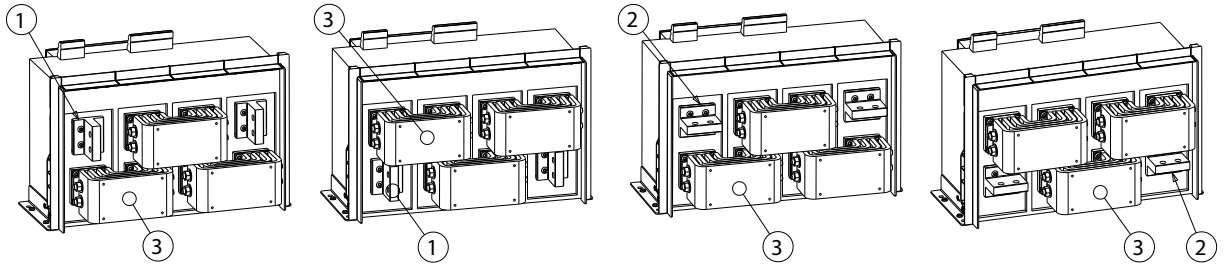

Upper supply VR

Lower supply VR

Upper supply HR

Lower supply HR

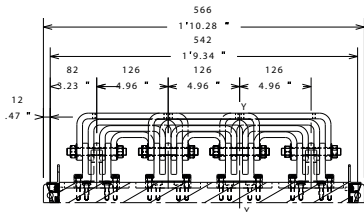

- Key
- 1 Vertical terminal 1600-2000A
  - 2 Horizontal terminal 1600-2000A
  - 3 Jumper 4C
  - 4 Phase separator

# UL Fixed execution

Vertical rear terminals - VR

E4.2 2500-3200A

## Configurations A & B

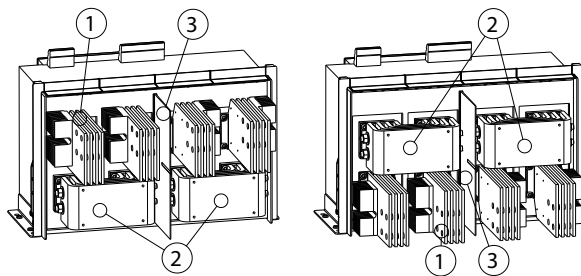

Upper supply

Lower supply

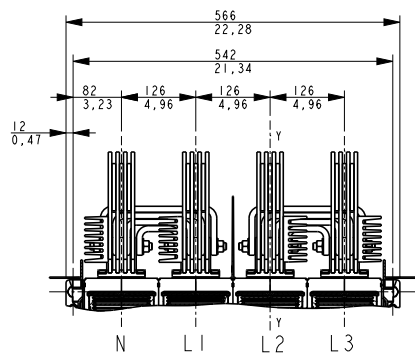

## Configurations C & D

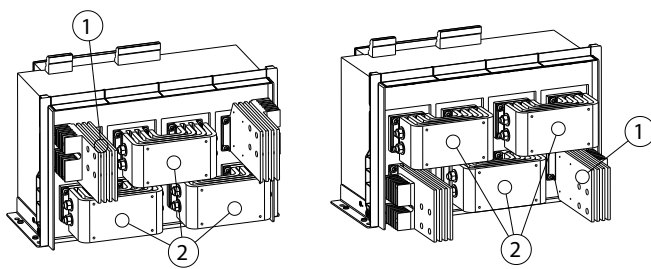

Upper supply

Lower supply

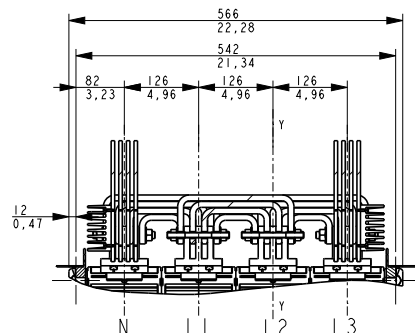

- Key
- 1 Vertical terminal 2500-3200A
  - 2 Jumper 4C
  - 3 Phase separator

# UL Withdrawable execution

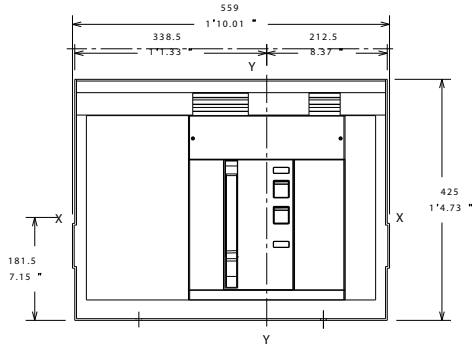

## Compartment door drilling

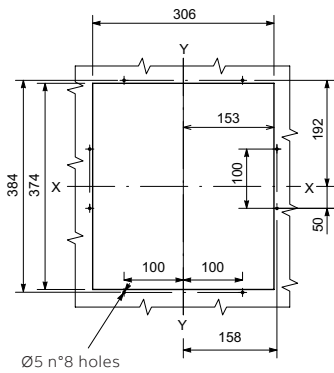

## Floor fixing

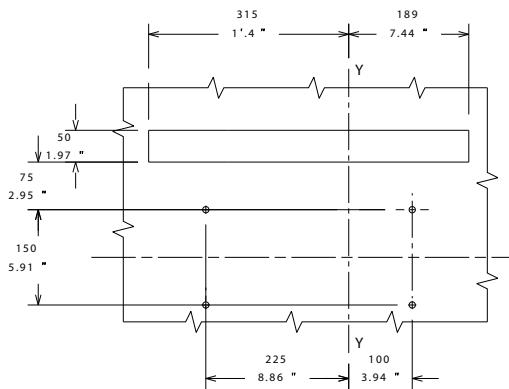

— Key  
1 Ventilation drilling on the switchgear

## Earthing device

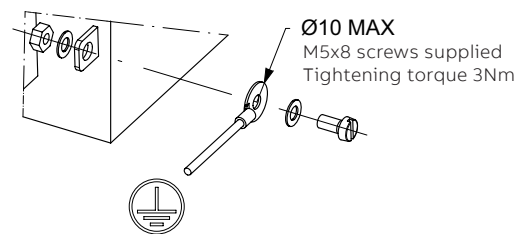

# UL Withdrawable execution

- Key  
 1 Phase separator  
 2 Connected, test, disconnected distances

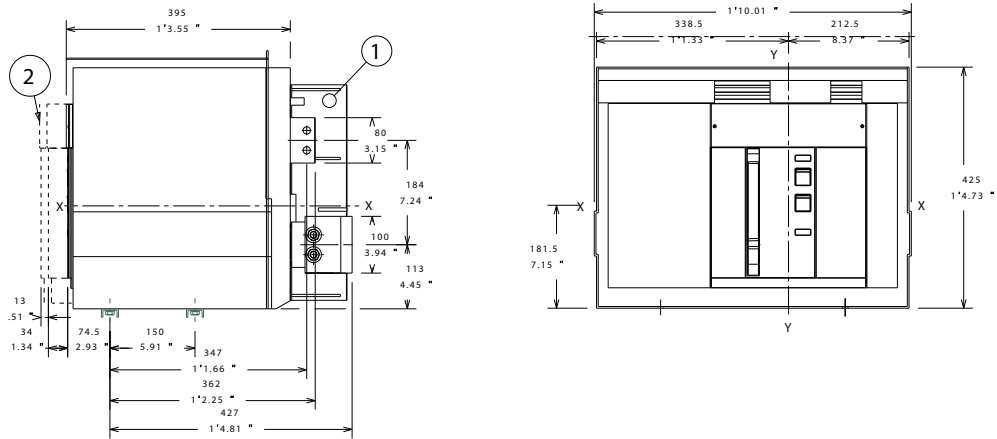

## E4.2 1600-2000A Terminals

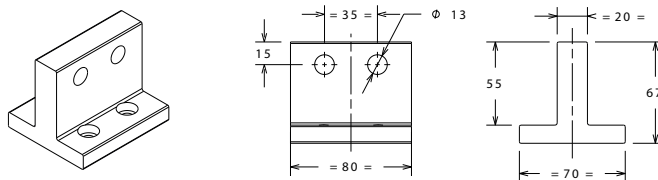

## E4.2 2500-3200A Terminals

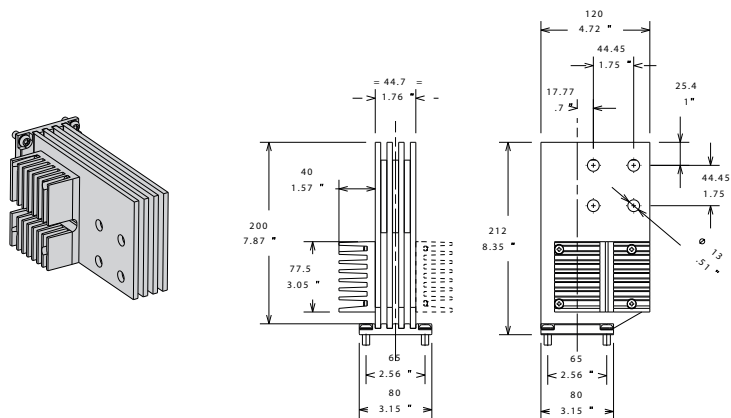



# UL Withdrawable execution

Vertical rear terminals - VR

E4.2 2500-3200A

Configurations A & B

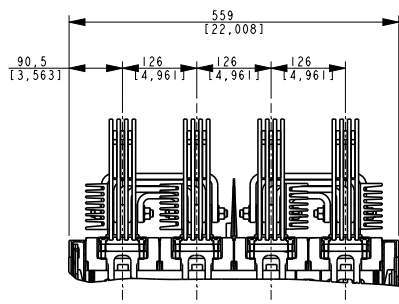
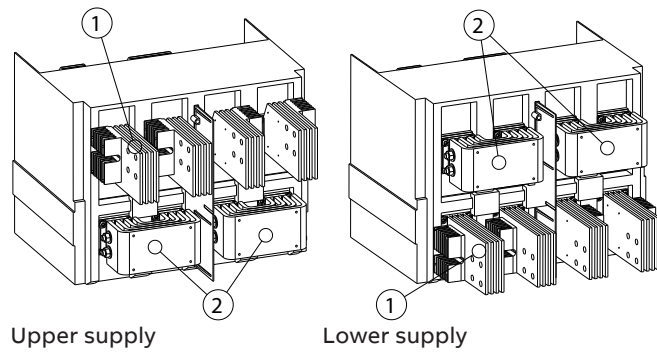

Configurations C & D

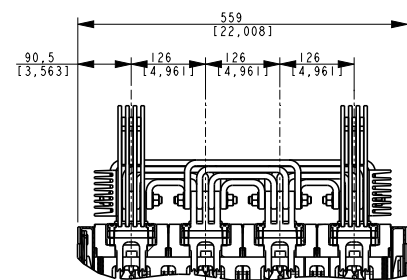
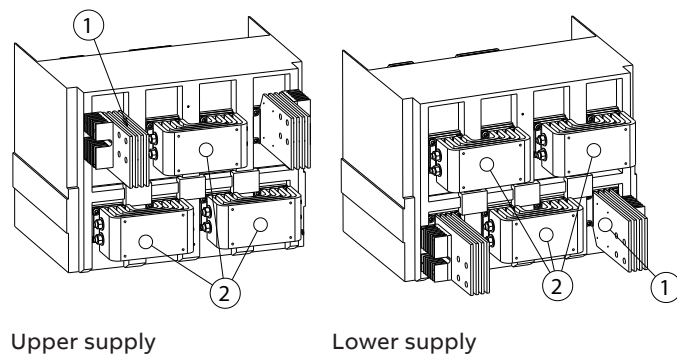

- Key
- 1 Vertical terminal 2500-3200A
  - 2 Jumper 4C



# Electrical accessories

51	61	71	81	91	01	95	35	R1	V3	Vn	Ge+	Szi	Ne-	45	D1	C1	C11	C21	11	21	31	41			
52	62	72	82	92	02	96	36	U1	R2	V2	Rct	Ge-	Szo	Ne+	46	C3	C13		12	22	32	42			
54	64	74	84	94	04	98	38	U2		V1	Gzo	Szc	Gzi	Rca	48	D2	C2	C12	C22	14	24	34	44		
Q5..Q10 EKIP Signalling 4K						S51	S33	M	YR	Trip Unit I/O															
						Module			Module			Module			EKIP Supply			TU I/O							

	D1	C1	C11	C21	11
		C3	C13		12
	D2	C2	C12	C22	14
	YU YO2	YC	YO	YC2	Q1

**77) First closing coil - YC**

**78) First closing coil with control from protection trip unit - YC, Ekup Com Actuator**

**79) Second closing coil - YC2**

77- 78 as an alternative to each other

79 valid only for E2.2 - E4.2 - E6.2

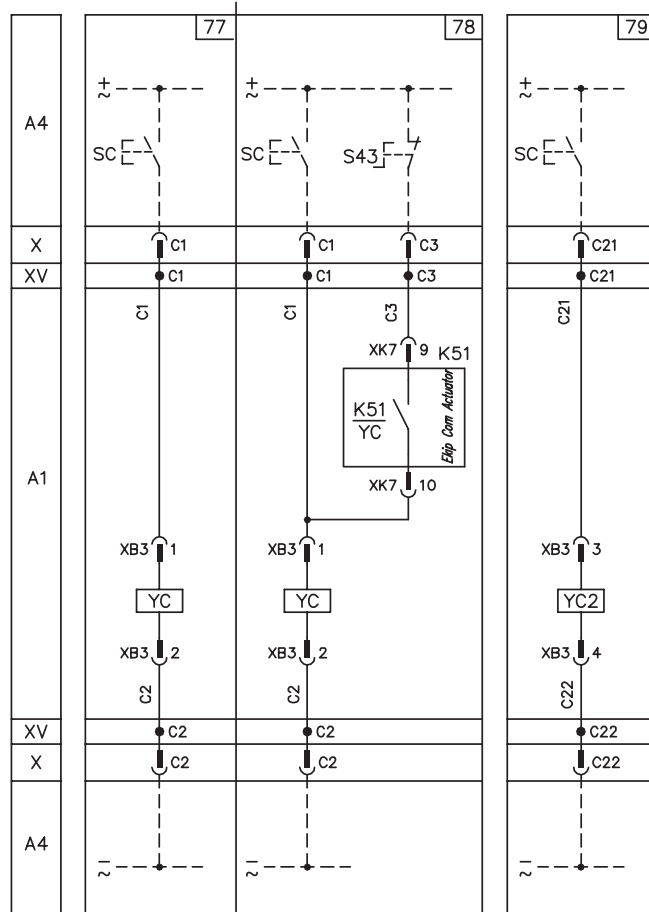

\*M)





51	61	71	81	91	01	95	35	R1	V3	Vn	Ge+	Szi	Ne-	45	D1	C1	C11	C21	11	21	31	41												
52	62	72	82	92	02	96	36	U1	R2	V2	Rct	Ge-	Szo	Ne+	46	C3	C13		12	22	32	42												
54	64	74	84	94	04	98	38	U2		V1	Gzo	Szc	Gzi	Rca	48	D2	C2	C12	C22	14	24	34	44											
Q5..Q10 EKIP Signalling 4K						S51	S33	M	YR	Trip Unit I/O			Module			Module			Module			EKIP Supply			TU I/O	RTC	YU YO2	YC	YO	YC2	Q1	Q2	Q3	Q4

51	61	71	81	91	01
52	62	72	82	92	02
54	64	74	84	94	04
Q5..Q10 EKIP Signalling 4K					

1) Supplementary open/closed auxiliary contacts of the circuit-breaker - AUX 6Q (6 Form C)

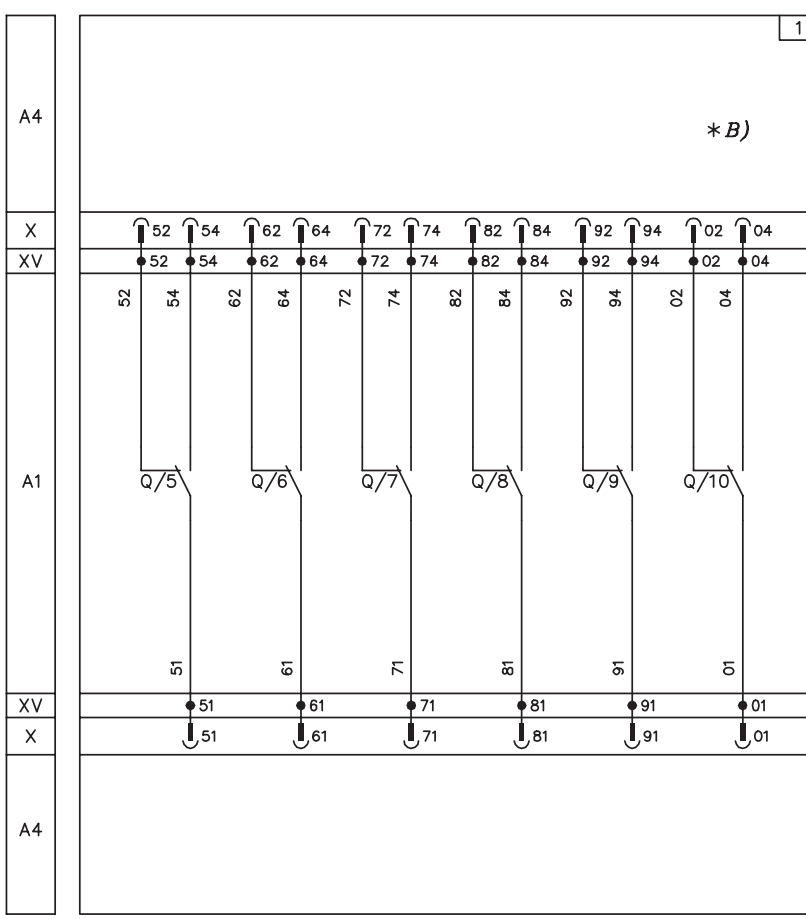

# Electrical accessories

## 91) Supplementary open/closed auxiliary contacts outside the circuit-breaker - AUX 15Q (15 Form C)

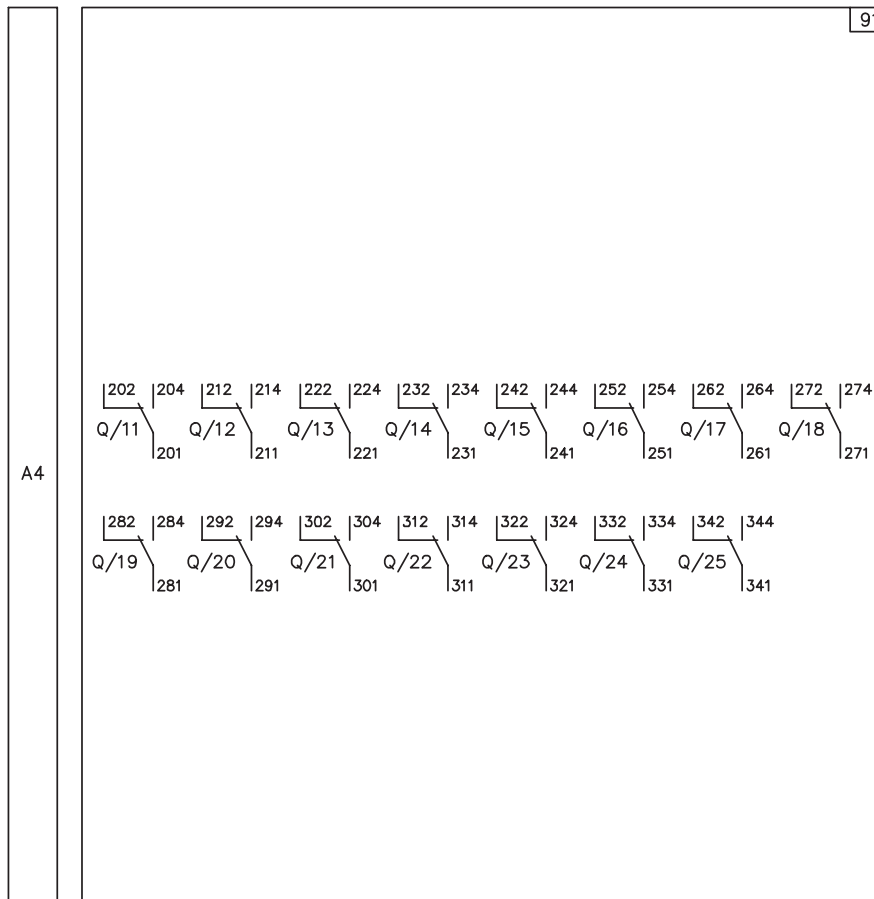

---

# Ordering codes

<b>5/2</b>	<b>General information</b>
<b>5/3</b>	<b>Network configurations</b>
<b>5/4</b>	<b>Instructions for ordering</b>
<b>5/4</b>	Configuration steps
<b>5/5</b>	Ordering examples
<b>5/6</b>	<b>IEC Switch-disconnectors</b>
<b>5/6</b>	Fixed version
<b>5/7</b>	Withdrawable version
<b>5/7</b>	Fixed parts
<b>5/8</b>	Connections setup
<b>5/9</b>	Horizontal terminals
<b>5/10</b>	Emax 2 MS/DC-E DC-20
<b>5/11</b>	<b>UL Switch-disconnectors</b>
<b>5/11</b>	Fixed version
<b>5/12</b>	Withdrawable version
<b>5/12</b>	Fixed parts
<b>5/13</b>	Connections setup
<b>5/14</b>	Horizontal terminals
<b>5/14</b>	Global multi-standard version
<b>5/15</b>	<b>Standard supply</b>
<b>5/16</b>	<b>Instructions for ordering</b>
<b>5/16</b>	SACE Emax 2 configured circuit breaker / switch disconnector order code breakdown
<b>5/19</b>	SACE Emax 2 cradle (fixed part) order code breakdown
<b>5/20</b>	<b>Accessories</b>
<b>5/20</b>	Spare parts

# General information

## Versions and terminals

F	Fixed circuit-breaker
W	Withdrawable circuit-breaker
MP	Mobile part of withdrawable circuit-breaker
FP	Fixed part of withdrawable circuit-breaker
HR	Horizontal rear terminals
VR	Vertical rear terminals
HR VR	Rear orientable terminals
MS	Switch-disconnector
MS/DC-E	Switch-disconnector for 1500V DC
I <sub>u</sub>	Rated uninterrupted current
I <sub>cu</sub>	Rated ultimate short-circuit breaking capacity
I <sub>cw</sub>	Rated short-time withstand current

# Network configurations

SACE Emax 2 MS/DC-E switch-disconnector can be installed in one of the following four configurations:

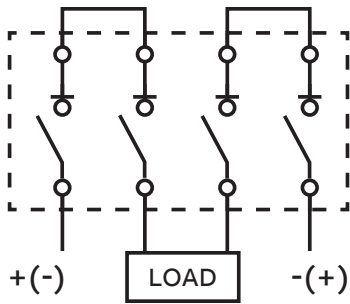
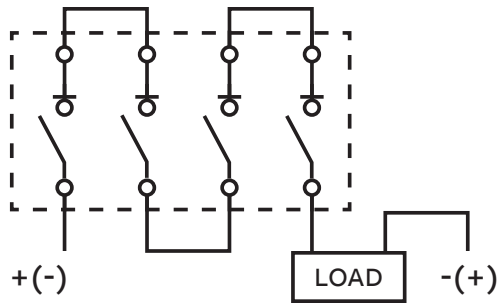
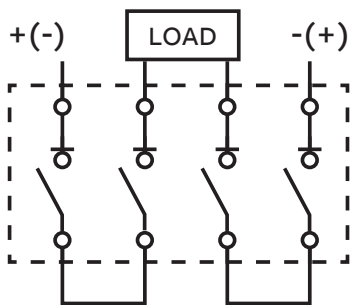
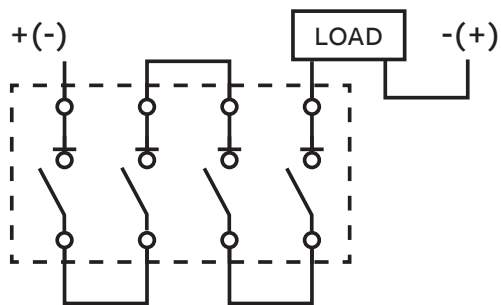
Configuration	Insulated network	Grounded polarity
Supply/load on lower side	Configuration A	Configuration C
		
Supply/load on upper side	Configuration B	Configuration D
		

- Configuration A:** insulated network (interrupting both polarities), supply/load connected to lower terminals.
- Configuration B:** insulated network (interrupting both polarities), supply/load connected to upper terminals.
- Configuration C:** grounded polarity (interrupting one polarity), supply/load connected to lower terminals.
- Configuration D:** grounded polarity (interrupting one polarity), supply/load connected to upper terminals.

Note: Supply terminals and load terminals are interchangeable.

# Instructions for ordering

## Configuration steps

SACE Emax 2 MS/DC-E switch-disconnector must be selected according to:

- Standard: IEC or UL;
- Execution: Fixed or Withdrawable;
- Rated current (Iu);
- Short-time withstand current (Icw);
- Type of network: grounded polarity or insulated network;
- Power supply and load connection: from upper or lower terminals
- Terminals orientation (HR/VR): vertical (standard) or horizontal\*

\* UL 2500/3200A ratings are available only with vertical rear terminals

To build the needed configuration, please follow those ordering steps:

Ordering steps	Ordering codes pages	
	IEC	UL
<b>1. Select code for switch-disconnector</b> One code for fixed execution, or two codes for drawables (mobile part + fixed part)	5/6	5/10
<b>2. Select code for connections setup</b> One code to define network configuration and supply/load side for terminals	5/8	5/12
<b>3. Add extracode for horizontal terminals HR</b> (optional)	5/9	5/13
<b>4. Add codes for accessories</b> (optional)	5/15	5/15

Note: IEC versions have also CCC approval.

For Global multi-standard version IEC+UL+CCC, please follow ordering steps for UL version and add extracode listed on page 5/13.

# Instructions for ordering

## Ordering examples

### Example no. 1

Emax 2 DC switch, IEC, rated 2000A, I<sub>cw</sub>=100kA, fixed, with vertical rear terminals (VR), for insulated network, connected by lower terminals

Code	Description	Comment
1SDA115417R1	E4.2V MS/DC-E 2000A 1500V 4p F VR	VR is the default setup for any Emax 2 DC switch
1SDA115478R1	KitJumpE4.2 1600-2500IEC -A- 2psLS INST	Terminals configuration A, for IEC up to 2500A

### Example no. 2

Emax 2 DC switch, IEC, rated 3200A, I<sub>cw</sub>=65kA, drawable, with horizontal rear terminals (HR), for grounded polarity, connected by upper terminals

Code	Description	Comment
1SDA115404R1	E4.2S MS/DC-E 3200A 1500V 4p W MP	Moving part
1SDA115427R1	E4.2 MS/DC-E 4000A 1500V 4p FP VR	Fixed part for IEC 3200-4000A
1SDA115475R1	KitJumpE4.2 3200-4000IEC -D- 4psUS INST	Terminals configuration D, for IEC 3200-4000A
1SDA115470R1	HR E4.2DC 3200-4000A IEC -CD- extra	Extracode for HR, configurat. C or D, IEC 3200-4000A

### Example no. 3

UL Emax 2 DC switch, rated 2500A, I<sub>cw</sub>=85kA, drawable, with vertical rear terminals (VR), for insulated network, connected by upper terminals

Code	Description	Comment
1SDA115445R1	E4.2H-A MS/DC-E 2500A 1500V 4p W MP	Moving part
1SDA115459R1	E4.2-A MS/DC-E 3200A 1500V 4p FP VR	Fixed part for UL 2500-3200A, VR only
1SDA115485R1	KitJumpE4.2 2500 UL -B- 2psUS INST	Terminals configuration B, for UL 2500A

### Example no. 4

Same as example no. 1, but multi-standard IEC+UL+CCC

Code	Description	Comment
1SDA115449R1	E4.2V-A MS/DC-E 2000A 1500V 4p F VR	Multi-standard is based on UL versions
1SDA115490R1	KitJumpE4.2 1600-2000 UL -A- 2psLS INST	Terminals configuration A, for UL up to 2000A
1SDA115460R1	CERT. UL/IEC/CCC E4.2MS/DC-E 1600-2500A	Extracode for multi-standard, up to 2500A

# IEC Switch-disconnectors



## Fixed version

### SACE Emax E4.2S-H-V MS/DC-E • Without jumpers (\*)

Size	Iu	Icw (1s)	Type	Global PN <sup>(1)</sup>	US / CA PN
E4.2S MS/DC-E	1600A	65	E4.2S MS/DC-E 1600 VR	1SDA115396R1	Configured part
	2000A		E4.2S MS/DC-E 2000 VR	1SDA115397R1	Configured part
	2500A		E4.2S MS/DC-E 2500 VR	1SDA115398R1	Configured part
	3200A		E4.2S MS/DC-E 3200 VR	1SDA115399R1	Configured part
	4000A		E4.2S MS/DC-E 4000 VR	1SDA115400R1	Configured part
E4.2H MS/DC-E	1600A	85	E4.2H MS/DC-E 1600 VR	1SDA115406R1	Configured part
	2000A		E4.2H MS/DC-E 2000 VR	1SDA115407R1	Configured part
	2500A		E4.2H MS/DC-E 2500 VR	1SDA115408R1	Configured part
	3200A		E4.2H MS/DC-E 3200 VR	1SDA115409R1	Configured part
	4000A		E4.2H MS/DC-E 4000 VR	1SDA115410R1	Configured part
E4.2V MS/DC-E	1600A	100	E4.2V MS/DC-E 1600 VR	1SDA115416R1	Configured part
	2000A		E4.2V MS/DC-E 2000 VR	1SDA115417R1	Configured part
	2500A		E4.2V MS/DC-E 2500 VR	1SDA115418R1	Configured part
	3200A		E4.2V MS/DC-E 3200 VR	1SDA115419R1	Configured part
	4000A		E4.2V MS/DC-E 4000 VR	1SDA115420R1	Configured part

\* Add code for connections setup (page 5/8).

(1) Configured part

# IEC Switch-disconnectors



## Withdrawable version

### SACE Emax E4.2S-H-V MS/DC-E • Mobile part of switch disconnector (MP)

Size	Iu	Icw (1s)	Type	Global PN	US / CA PN
E4.2S MS/DC-E	1600A	65	E4.2S MS/DC-E 1600	1SDA115401R1	PCSS00A000000000000XX
	2000A		E4.2S MS/DC-E 2000	1SDA115402R1	PCST00A000000000000XX
	2500A		E4.2S MS/DC-E 2500	1SDA115403R1	PCSU00A000000000000XX
	3200A		E4.2S MS/DC-E 3200	1SDA115404R1	PCSV00A000000000000XX
	4000A		E4.2S MS/DC-E 4000	1SDA115405R1	PCSW00A000000000000XX
E4.2H MS/DC-E	1600A	85	E4.2H MS/DC-E 1600	1SDA115411R1	PCHS00A000000000000XX
	2000A		E4.2H MS/DC-E 2000	1SDA115412R1	PCHT00A000000000000XX
	2500A		E4.2H MS/DC-E 2500	1SDA115413R1	PCHU00A000000000000XX
	3200A		E4.2H MS/DC-E 3200	1SDA115414R1	PCHV00A000000000000XX
	4000A		E4.2H MS/DC-E 4000	1SDA115415R1	PCHW00A000000000000XX
E4.2V MS/DC-E	1600A	100	E4.2V MS/DC-E 1600	1SDA115421R1	PCVS00A000000000000XX
	2000A		E4.2V MS/DC-E 2000	1SDA115422R1	PCVT00A000000000000XX
	2500A		E4.2V MS/DC-E 2500	1SDA115423R1	PCVU00A000000000000XX
	3200A		E4.2V MS/DC-E 3200	1SDA115424R1	PCVV00A000000000000XX
	4000A		E4.2V MS/DC-E 4000	1SDA115425R1	PCVW00A000000000000XX



## Fixed parts

### Without jumpers (\*)

Size	Performance	Iu range	Type	Global PN <sup>(1)</sup>	US / CA PN
E4.2	S, H, V	1600-2500A	E4.2 MS/DC-E WFP Iu=2500 VR	1SDA115426R1	Configured part
E4.2	S, H, V	3200-4000A	E4.2 MS/DC-E WFP Iu=4000 VR	1SDA115427R1	Configured part

\* Add code for connections setup (page 5/8).  
 (1) Configured part

# IEC Switch-disconnectors

## Connections setup

Kit for jumper busbars - installed on fixed breaker (F) or fixed part of withdrawable breaker (FP)

Network configuration		1600-2000-2500 A			3200-4000 A			
ID	Description	Scheme	Figure	Global PN <sup>(2)</sup>	US / CA PN	Figure	Global PN <sup>(2)</sup>	US / CA PN
A	insulated network, lower terminals	Configuration A 		1SDA115478R1	Factory Installed code only		1SDA115474R1	Factory Installed code only
B	insulated network, upper terminals	Configuration B 		1SDA115477R1	Factory Installed code only		1SDA115473R1	Factory Installed code only
C	grounded polarity, lower terminals.	Configuration C 		1SDA115480R1	Factory Installed code only		1SDA115476R1	Factory Installed code only
D	grounded polarity, upper terminals.	Configuration D 		1SDA115479R1	Factory Installed code only		1SDA115475R1	Factory Installed code only

Note: for network configurations A and B, separator plate is provided.

(2) Factory Installed code only

# IEC Switch-disconnectors

## Horizontal terminals

IEC breakers are provided with adjustable rear terminals, mounted in vertical configuration (VR). It is possible to order breakers with rear terminals as factory mounted in horizontal configuration (HR), adding one of the following extracodes:

### Extracode for horizontal rear terminals (HR)

Size	Iu range	Network Configuration	Global PN <sup>(2)</sup>	US / CA PN
E4.2	1600-2500A	A	1SDA115467R1	Factory Installed code only
		B		
		C	1SDA115468R1	Factory Installed code only
		D		
	3200-4000A	A	1SDA115469R1	Factory Installed code only
		B		
		C	1SDA115470R1	Factory Installed code only
		D		

(2) Factory Installed code only

# IEC Switch-disconnectors

## Emax 2 MS/DC-E DC-20

### Connection scheme

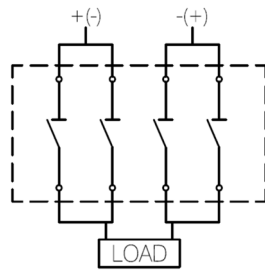

Parallel links between poles are provided as internal, factory mounted feature. Supply terminals and load terminals are interchangeable.

### Ordering codes

	Iu	Type	Code
Mobile part	6000	E4.2V MS/DC-E DC-20 W MP	1SDA122994R1
Fixed part	6000	E4.2 MS/DC-E DC-20 FP LHR LHR	1SDA122995R1

Note: for terminals in vertical setup, add following codes to Fixed Part configuration: 1SDA117316R1 and 1SDA117317R1.

### Accessories

SACE Emax 2 MS/DC-E DC-20 can be fitted with a vast assortment of electrical and mechanical accessories already available for the standard SACE Emax 2 range.

Phase separator (PB) and Protection for ON-OFF pushbuttons (PBC) are provided by default. Under-voltage release (YU) cannot be provided.

# UL Switch-disconnectors



## Fixed version

### SACE Emax E4.2S-A, H-A, V-A MS/DC-E • Without terminals (\*)

Size	Iu	Icw (1s)	Type	Global PN <sup>(1)</sup>	US / CA PN
E4.2S-A MS/DC-E	1600A	65	E4.2S-A MS/DC-E 1600 VR	1SDA115428R1	Configured part
	2000A		E4.2S-A MS/DC-E 2000 VR	1SDA115429R1	Configured part
	2500A		E4.2S-A MS/DC-E 2500 VR	1SDA115430R1	Configured part
	3200A		E4.2S-A MS/DC-E 3200 VR	1SDA115431R1	Configured part
E4.2H-A MS/DC-E	1600A	85	E4.2H-A MS/DC-E 1600 VR	1SDA115438R1	Configured part
	2000A		E4.2H-A MS/DC-E 2000 VR	1SDA115439R1	Configured part
	2500A		E4.2H-A MS/DC-E 2500 VR	1SDA115440R1	Configured part
	3200A		E4.2H-A MS/DC-E 3200 VR	1SDA115441R1	Configured part
E4.2V-A MS/DC-E	1600A	100	E4.2V-A MS/DC-E 1600 VR	1SDA115448R1	Configured part
	2000A		E4.2V-A MS/DC-E 2000 VR	1SDA115449R1	Configured part
	2500A		E4.2V-A MS/DC-E 2500 VR	1SDA115450R1	Configured part
	3200A		E4.2V-A MS/DC-E 3200 VR	1SDA115451R1	Configured part

\* Add code for connections setup (page 5/12).

(1) Configured part

# UL Switch-disconnectors



## Withdrawable version

### SACE Emax E4.2S-A, H-A, V-A MS/DC-E • Mobile part of switch-disconnector (MP)

Size	Iu	Icw (1s)	Type	Global PN	US / CA PN
E4.2S-A MS/DC-E	1600A	65	E4.2S-A MS/DC-E 1600	1SDA115433R1	PCSE00A000000000000XX
	2000A		E4.2S-A MS/DC-E 2000	1SDA115434R1	PCSF00A000000000000XX
	2500A		E4.2S-A MS/DC-E 2500	1SDA115435R1	PCSG00A000000000000XX
	3200A		E4.2S-A MS/DC-E 3200	1SDA115436R1	PCSH00A000000000000XX
E4.2H-A MS/DC-E	1600A	85	E4.2H-A MS/DC-E 1600	1SDA115443R1	PCHE00A000000000000XX
	2000A		E4.2H-A MS/DC-E 2000	1SDA115444R1	PCHF00A000000000000XX
	2500A		E4.2H-A MS/DC-E 2500	1SDA115445R1	PCHG00A000000000000XX
	3200A		E4.2H-A MS/DC-E 3200	1SDA115446R1	PCHH00A000000000000XX
E4.2V-A MS/DC-E	1600A	100	E4.2V-A MS/DC-E 1600	1SDA115453R1	PCVE00A000000000000XX
	2000A		E4.2V-A MS/DC-E 2000	1SDA115454R1	PCVF00A000000000000XX
	2500A		E4.2V-A MS/DC-E 2500	1SDA115455R1	PCVG00A000000000000XX
	3200A		E4.2V-A MS/DC-E 3200	1SDA115456R1	PCVH00A000000000000XX



## Fixed parts

### Without terminals (\*)

Size	Performance	Iu range	Type	Global PN <sup>(1)</sup>	US / CA PN
E4.2	S-A, H-A, V-A	1600-2000A	E4.2-A MS/DC-E W FP Iu=2000 VR	1SDA115458R1	Configured part
E4.2	S-A, H-A, V-A	2500-3200A	E4.2-A MS/DC-E W FP Iu=3200 VR	1SDA115459R1	Configured part

\* Add code for connections setup (page 5/12).

(1) Configured part

# UL Switch-disconnectors

## Connections setup

Kit for terminals and jumper busbars - installed on fixed breaker (F) or fixed part of withdrawable breaker (FP)

Network configuration			1600-2000A		2500A		3200A			
ID	Description	Scheme	Figure	Global PN <sup>(2)</sup>	US / CA PN	Figure	Global PN <sup>(2)</sup>	US / CA PN	Global PN <sup>(2)</sup>	US / CA PN
A	insulated network, lower terminals	<p>Configuration A</p>		1SDA115490R1	Factory Installed code only		1SDA115486R1	Factory Installed code only	1SDA115482R1	Factory Installed code only
B	insulated network, upper terminals	<p>Configuration B</p>		1SDA115489R1	Factory Installed code only		1SDA115485R1	Factory Installed code only	1SDA115481R1	Factory Installed code only
C	grounded polarity, lower terminals.	<p>Configuration C</p>		1SDA115492R1	Factory Installed code only		1SDA115488R1	Factory Installed code only	1SDA115484R1	Factory Installed code only
D	grounded polarity, upper terminals.	<p>Configuration D</p>		1SDA115491R1	Factory Installed code only		1SDA115487R1	Factory Installed code only	1SDA115483R1	Factory Installed code only

Note: for network configurations A and B, separator plate is provided.  
 (2) Factory Installed code only

# UL Switch-disconnectors

## Horizontal terminals

UL Breakers are provided with rear terminals mounted in vertical configuration (VR).

For UL ratings 2500A and 3200A, VR is the only available configuration and cannot be modify into horizontal (HR).

For UL ratings 1600A and 2000A, it is possible to order breaker with rear terminals factory mounted in horizontal configuration (HR), adding one of the following extracodes:

### Extracode for horizontal rear terminals (HR)

Size	Iu range	Network Configuration	Global PN <sup>(2)</sup>	US / CA PN
E4.2	1600-2000A	A	1SDA115467R1	Factory Installed code only
		B		
		C	1SDA115468R1	Factory Installed code only
		D		

(2) Factory Installed code only

### Global multi-standard version IEC, UL and CCC

For Global multi-standard version IEC 60947-3, UL489, and CCC, follow ordering steps for UL versions and add following extracode:

Size	Iu range	Description	Global PN <sup>(2)</sup>	US / CA PN
E4.2	1600-2500A	CERT. UL/IEC/CCC E4.2MS/DC-E 1600-2500A	1SDA115460R1	Factory Installed code only
	3200A	CERT. UL/IEC/CCC E4.2MS/DC-E 3200A	1SDA117162R1	Factory Installed code only

(2) Factory Installed code only

# Standard supply

The fixed versions of SACE Emax 2 DC switch-disconnectors are always supplied as standard with the following accessories:

- IP30 protection for switchgear door
- lifting plates
- adjustable rear terminals\*, mounted in VR configuration
- separator plate for network configurations A and B.

The withdrawable versions of switch-disconnectors are always supplied as standard with the following accessories:

- closed circuit-breaker racked-out mechanism lock
- lifting plates
- lever for racking in and racking out
- anti-insertion lock.

The fixed part of with drawable versions features:

- IP30 protection for switchgear door
- anti-insertion lock
- standard shutter lock – SL
- adjustable rear terminals\*, mounted in VR configuration
- separator plate for network configurations A and B.

\* UL 2500/3200A ratings are available only with non-adjustable vertical rear terminals

# Instructions for ordering

## SACE Emax 2 configured circuit breaker / switch disconnector order code breakdown



### 1 - Emax 2 Prefix

P	DC (1500VDC)
---	--------------

### 3 - Short-time withstand (1s)/ Version

	S	V	H
UL kA @ 1500VDC	65	85	100
IEC kA @ 1500VDC	65	85	100

### 5 & 6 - Rating Plug [A]

Switch	00
--------	----

### 2 - Frame

E4.2
------

4p	C
----	---

### 4 - Frame Rating [A]

	E	F	G	H	
UL	1600	2000	2500	3200	
	S	T	U	V	W
IEC	1600	2000	2500	3200	4000

### 7 - Fixed/Drawout and Terminal connections

	DC Insulated Network (2+2ps) Upper	DC Insulated Network (2+2ps) Lower	DC Grounded Polarity (4ps) Upper	DC Grounded Polarity (4ps) Lower
Drawout (less cradle)	A			
Fixed (std. terminals)	I	Z	9	1

### 8 - Ekip Trip Unit

Switch Disconnector	0
---------------------	---

### 9 - Auxiliary Power Supply (Ekip Supply) and Measuring

None	0
------	---

### 10 - Communication Modules

None	0
------	---

### 11 - Redundant Communications and Additional Ekip Modules

None	0
------	---

### 12 - Auxiliary Contacts (AUX) and Additional Signaling (4K)

None	0			
	-	4 AUX (4Q) 400V	4 AUX (4Q) 24V	4 AUX (2Q+2Q) 24 & 400V
	-	A	B	C
6 AUX (6Q) 400V <sup>(1)</sup>	D	E	F	G
6 AUX (6Q) 24V <sup>(1)</sup>	H	J	K	L
6 AUX (3Q+3Q) 400 & 24V <sup>(1)</sup>	M	N	P	Q

### 13 - Remote Reset (YR), 2nd Bell Alarm (S51/2), Ready to Close Contacts (RTC), and Disabling Bluetooth + Sealable Cover

None	0
RTC 24VDC	D
RTC 250V AC/DC	H

**14 - Closing Coil (YC) and Redundant Closing Coil (YC2)**

None	0											
	24V AC/DC	30V AC/DC	48V AC/DC	60V AC/DC	110-120V AC/DC	120-127V AC/DC	220-240V AC/DC	240-250V AC/DC	380-400V AC	415-440V AC	480-500V AC	
YC	A	B	C	D	E	F	G	H	K	L	M	
YC + YC2	N	P	Q	R	S	T	U	V	X	Y	Z	

Note: YC2 will have the same control voltage as YC1

**15 - Opening Coil (YO)**

None	0											
	24V AC/DC	30V AC/DC	48V AC/DC	60V AC/DC	110-120V AC/DC	120-127V AC/DC	220-240V AC/DC	240-250V AC/DC	380-400V AC	415-440V AC	480-500V AC	
YO	A	B	C	D	E	F	G	H	K	L	M	

**16 - Undervoltage Release (UVR) or Redundant Opening Coil (YO2)**

None	0											
	24V AC/DC	30V AC/DC	48V AC/DC	60V AC/DC	110-120V AC/DC	120-127V AC/DC	220-240V AC/DC	240-250V AC/DC	380-400V AC	415-440V AC	480-500V AC	
UVR	A	B	C	D	E	F	G	H	K	L	M	
YO2 Only	N	P	Q	R	S	T	U	V	X	Y	Z	

**17 - Spring Charging Motor (M) and Ekip Com Actuator**

None	0						
	24-30V AC/DC	48-60V AC/DC	100-130V AC/DC	220-250V AC/DC	380-415V AC	440-480V AC <sup>(1)</sup>	
M with standard aux. for status indication of springs	2	3	4	5	7	8	
M with 24VDC aux. contacts for status indication of springs	A	B	C	D	F	G	

**18 - Push Button Locking Options**

None	0							
		Push Button Covers (PBC)				Padlock in Open Position (PLC)		
		PBC Special Key	PBC Padlock (4mm)	PBC Padlock (7mm)	PBC Padlock (8mm)	PLC - 4mm	PLC - 7mm	PLC - 8mm
		2	3	4	5	6	7	8
Key Lock in Open Position - Different Keys (KLC-D)	A	D	E	F	G	H	J	K
Key Lock in Open Position - Same Keys (KLC-S) <sup>(1)</sup>	B	L	M	N	P	Q	R	S
Key Lock in Open Position - Kirk Key provisions (KLC-A)	C	T	I	V	W	X	Y	Z

(1) Standard key for Same Key option is #20005. Locks for #20006 - 20009 are available for order as loose accessories.  
 Note: Key lock options for Castell and Ronis/Profalux are available for order as loose accessories.

05

# Instructions for ordering

## SACE Emax 2 configured circuit breaker / switch disconnecter order code breakdown

### 19 - Racking Lock Options (1st lock) and Factory Test Report

None	X	Keylock in racked in/out - Same Keys (KLP-S) <sup>(1)</sup>	Keylock in racked in/out - Different Keys (KLP-D) <sup>(1)</sup>	Keylock in racked in/out - Kirk/Ronis/Profulaux provisions (KLP-A) <sup>(1)</sup>	Keylock in racked in/out - Castell provisions (KLP-A) <sup>(2)</sup>
	-	A	B	C	D
<b>Padlock in racked in/out position (PLP)</b>	E	F	G	H	J

(1) Standard key for Same Key option is #20005. Locks for #20006 - 20009 are available for order as loose accessories.

(2) Two Castell adapter cannot be used at once, but can be used in either position with another style of lock.

Note: Racking locks are for E2.2 - E6.2. For E1.2 they are configured within the cradle.

### 20 - 2nd Racking Lock Options, Mechanical Operations Counter (MOC) and Extended Warranty'+A+A108:AG127

None	X	Keylock in racked in/out - Same Keys (KLP-S) <sup>(1)</sup>	Keylock in racked in/out - Different Keys (KLP-D) <sup>(1)</sup>	Keylock in racked in/out - Kirk/Ronis/Profulaux provisions (KLP-A) <sup>(1)</sup>	Keylock in racked in/out - Castell provisions (KLP-A) <sup>(2)</sup>
		B	C	D	E
<b>Mechanical Operations Counter (MOC)</b>	A	F	G	H	J
<b>2 Year Extended Warranty</b>	2	N	R	U	Y
<b>4 Year Extended Warranty</b>	4	P	S	V	Z
<b>5 Year Extended Warranty</b>	5	Q	T	W	6
<b>Additional Combinations</b>					
<b>MOC + 2 Year Extended Warranty</b>	K	7	-	-	-
<b>MOC + 4 Year Extended Warranty</b>	L	8	-	-	-
<b>MOC + 5 Year Extended Warranty</b>	M	9	-	-	-

Note: for additional combinations please contact your local ABB sales person

# Instructions for ordering SACE Emax 2 cradle (fixed part) order code breakdown



### 1 - Emax 2 Prefix

P	1500VDC
---	---------

### 3 - Standard

UL	A
IEC	C

### 6 - Terminal Connections

DC Insulated Network (2+2ps) Upper	I
DC Insulated Network (2+2ps) Lower	Z
DC Grounded Polarity (4ps) Upper	9
DC Grounded Polarity (4ps) Lower	1

### 7 - Auxiliary Cradle Position Contacts (AUP)

None	0				
	6 AUP (400VAC)	6 AUP (24VDC)	5 AUP (400VAC)	5 AUP (24VDC)	-
E2.2 - E6.2 Left position	-	-	C	D	-
E2.2 - E6.2 Right position	-	-	E	F	-
E2.2 - E6.2 Left & Right positions	-	-	G	H	J <sup>(1)</sup>

(1) Includes one 400V set (left) and one 24VDC set (right)

### 8 - Racking Lock Options (1st lock)

None	X				
		Keylock in racked in/out - Same Keys (KLP-S) <sup>(1)</sup>	Keylock in racked in/out - Different Keys (KLP-D) <sup>(1)</sup>	Keylock in racked in/out - Kirk/Ronis/Profulaux provisions (KLP-A) <sup>(1)</sup>	Keylock in racked in/out - Castell provisions (KLP-A) <sup>(2)</sup>
		A	B	C	D
Padlock in racked in/out position (PLP)	E	F	G	H	J
Racked out Position Lock (Supplementary)	K (3)	L	M	N	P
PLP + Racked out Position Lock	Q	R	S	T	U

(1) Standard key for Same Key option is #20005. Locks for #20006 - 20009 are available for order as loose accessories.

(2) Two Castell adapter cannot be used at once, but can be used in either position with another style of lock

(3) Available for E2.2-E6.2 and only if a racking lock option has been selected on the circuit breaker side

Note: Racking locks are for E1.2. For E2.2 - E6.2 they are configured within the circuit breaker

### 9 - 2nd Racking Lock Options

None	X				
		Keylock in racked in/out - Same Keys (KLP-S) <sup>(1)</sup>	Keylock in racked in/out - Different Keys (KLP-D) <sup>(1)</sup>	Keylock in racked in/out - Kirk/Ronis/Profulaux provisions (KLP-A) <sup>(1)</sup>	Keylock in racked in/out - Castell provisions (KLP-A) <sup>(2)</sup>
		B	C	D	E

(1) Standard key for Same Key option is #20005. Locks for #20006 - 20009 are available for order as loose accessories.

(2) Two Castell adapter cannot be used at once, but can be used in either position with another style of lock

Note: Racking locks are for E1.2. For E2.2 - E6.2 they are configured within the circuit breaker

# Accessories

## Spare parts

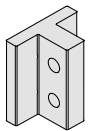

A

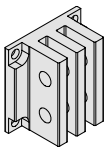

B

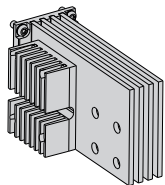

C

### Kit for terminals

Size	IEC/UL	Iu range	Version	Figure	2 pieces		4 pieces	
					Global PN	US / CA PN	Global PN	US / CA PN
E4.2	IEC	1600-2500	F; W (FP)	A	1SDA115462R1	ZE4HRVR25DC-2	1SDA115464R1	ZE4HRVR25DC-4
E4.2	IEC	3200-6000	F; W (FP)	B	1SDA115461R1	ZE4HRVR40DCE-2	1SDA115463R1	ZE4HRVR40DCE-4
E4.2	UL	1600-2000	F; W (FP)	A	1SDA115462R1	ZE4HRVR25DC-2	1SDA115464R1	ZE4HRVR25DC-4
E4.2	UL	2500-3200	F; W (FP)	C	1SDA115465R1	ZE4VR32DC-2	1SDA115466R1	ZE4VR32DC-4

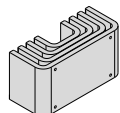
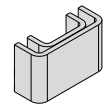

### Kit for jumper busbars

Size	IEC/UL	Iu range	Version	Type	Quantity (pcs)	Global PN	US / CA PN
E4.2	IEC	1600-2500	F; W (FP)	"2C" jumper kit	1	1SDA115472R1	ZE4JP25DC-1
E4.2	IEC	3200-4000	F; W (FP)	"4C" jumper kit	1	1SDA115471R1	ZE4JP40DC-1
E4.2	UL	1600-2000	F; W (FP)				
E4.2	UL	2500-3200	F; W (FP)				

Those spare parts are specific for Emax 2 DC.

The complete ordering codes for original and guaranteed spare parts are available in the ABB SACE Low voltage Spare Parts catalogue.





—

**ABB S.p.A.**

5, Via Pescaria

I-24123, Bergamo

Phone: +39 035 395.111

**[www.abb.com](http://www.abb.com)**