

Troubleshooting guide

If you have installed and connected the fitting as per the instructions listed earlier and it does not function correctly, use the following table as a guide to fixing the problem. Look up the type of fault in the left column and check the possible causes from the right column.

If the fitting still does not work after checking these possible causes, contact ABB customer service in Australia on 1800 60 20 20.

No.	Fault	Possible causes
1	LED light source and indicating LED not lit	AC supply not connected; or AC supply turned off
2	LED light source is lit but indicating LED not lit	Battery not connected or faulty
3	LED light source does not switch to emergency mode when the test button is pressed	Test switch damaged; or Battery not connected or faulty
4	LED light source works momentarily on emergency when the test button is pressed	Battery not yet charged (allow up to 24 hours)

INSTALLATION MANUAL

Stanilite® Platinum exit LED evago DALI emergency



Thank you for choosing ABB product

Please read this document thoroughly before commencing installation and retain for future reference. Contact ABB customer service in Australia on 1800 60 20 20 if you need any assistance. The installation instructions were correct at the time of print. To reflect changes in technology and Australian standards; ABB reserves the right to amend the instructions without notice. Updated document can be found on the Stanilite website.

Safety warning

In Australia and New Zealand, only licensed electricians are permitted by law to work with 240 volt electrical installations. Do not attempt to install or connect this product unless you are a licensed electrician. Turn off and isolate the electrical supply before connecting this fitting to the building wires. Do not touch the terminals of the terminal block when the light fitting is energised. The only user-serviceable part is the battery pack. LED light source is not user-serviceable. Do not attempt to service other parts of the fitting as this will void the warranty. As the installer, it is your responsibility to ensure

This document covers

Safety warning
Installation instructions
Testing precautions
Troubleshooting guide

What's inside the box

Exit LED evago
Installation manual
Warranty information

compliance with all relevant building and safety codes, (ie: AS/NZS 3000, AS/NZS 2293). Refer to the applicable standards for data and mains cabling installation procedures and requirements.

Important to note:

- This product is designed for indoor use only.

DALI (Digital Addressable Lighting Interface)

DALI is widely acknowledged as being an open protocol as defined under IEC 62386 and is designed only for communication in lighting systems.

ABB exit and emergency luminaire with DALI functionality comply with DALI standard IEC 62386.

The DALI evago wiring consists of additional 2 control wires apart from the active and neutral wires (4 cores) in a power cord supplied with product.

Note: No mains or mains carrying cables are to be connected to DALI terminals or 2 control wires (white and black).

ABB Australia Pty Limited

For enquiries
ABB contact centre: 1800 60 20 20
E-mail: AU-ABB-Stanilite@abb.com

Important: Carefully read this installation manual before installing or using the fitting. This installation manual provides important information about the correct installation, use, maintenance and disposal of this product.

Please observe the following guidelines

1. The fitting should only be installed by qualified personnel and installation must be in accordance with AS/NZS 3000 and local regulations.
2. This product may not be modified in any way what so ever or used for a purpose or in an environment other than for which it is designed. Failing to observe these guidelines will invalidate the warranty and the compliance of this product.
3. Before installing the fitting, the supply must be isolated.
4. The light source in this fitting is non-replaceable.

Installing and connecting

1. This fitting should be connected to the voltage equivalent to that indicated on the type label. This fitting is fitted with a terminal block suitable for loop-in-loop-out connection. The earth terminal is provided for convenience of wiring through only and should not form part of any protective shield. For further information on the different connection possibilities, see the instructions in this installation manual.

Installation instructions

Important: Triangular markings indicate how to place the e-box with respect to the first-fix. Check correct orientation before placing first-fix.

Connecting

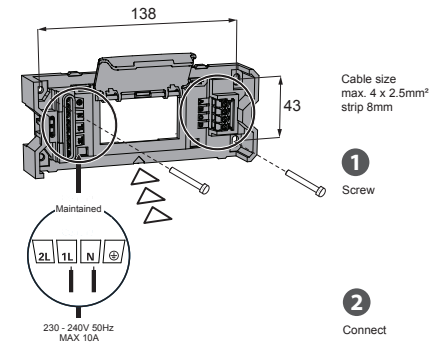

Exploded view

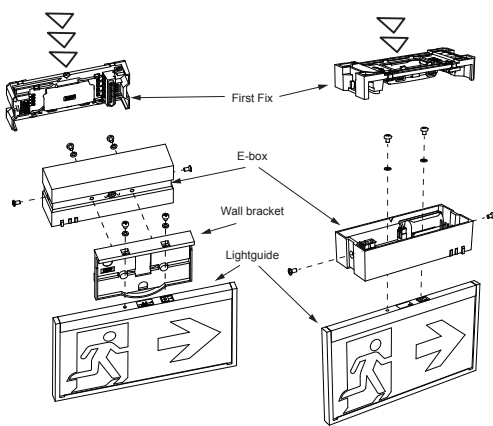

1. Evago mains wiring brown to (active), blue to (neutral), white to (DALI +) and black to (DALI -).

Ceiling

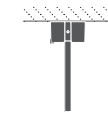

Wall

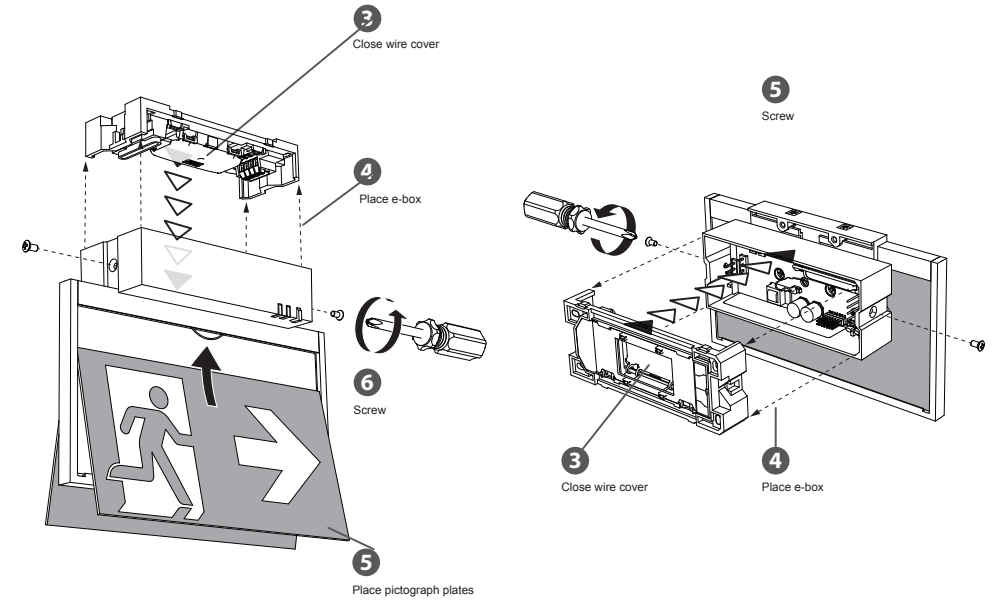

Important: 24 hours is required to allow the fitting battery to reach full capacity, ie: prior to a discharge test. As the installer, it is your responsibility to conduct the initial discharge testing of the installed fitting. Refer to AS/NZS 2293.

Testing precautions

Once the fitting is permanently connected to the mains supply, a commissioning discharge test as required in AS/NZS 2293.2 must be carried out. You will need to allow 24 hours for the battery to fully charge prior to conducting this test, presently (at the time of writing), the standard requires that fittings operate in emergency mode for a period not less than 2 hours for their commissioning test and for not less than 90 minutes thereafter (it is required that 6 monthly discharge tests be carried out). You will need to keep the records for the commissioning test and enter them into the building emergency services logbook or via other recording methods as allowed by AS/NZS 2293.2.

Construction sites

Continuously switching off the mains power supply that is connected to emergency light fittings during the construction phase of an installation will cause these fittings to discharge and charge their batteries many times over a short period; this can shorten life of the battery. ABB does not recommend such practices and may not honour the warranty on batteries when they are subjected to such harsh operating conditions. Emergency light fittings are designed to be discharge tested once every 6 months as per AS/NZS 2293.2, subjecting the product to repeated discharge or charge cycles is regarded as an abuse of the fittings.