

en Installation Instructions  
 fr Notice de montage  
 de Montageanweisung  
 es Instrucciones de montaje  
 it Istruzioni di montaggio  
 sv Installation och skötsel

DB45E

2CDC107016M5502 (a)

ABB STOTZ-KONTAKT GmbH  
 Eppelheimer Str. 82  
 69123 Heidelberg  
 Germany  
 http://www.abb.com/lowvoltage

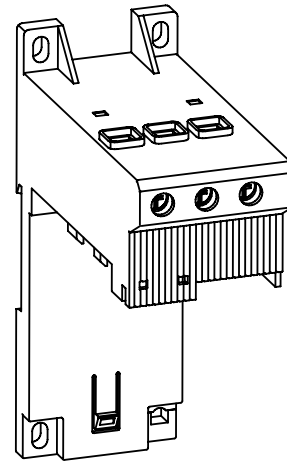

Warning!

en Installation and maintenance have to be performed according to the technical rules, codes and relevant standards, e.g. EN 60204 part 1, by skilled electricians only.

Avertissement!

fr L'installation et la maintenance de cet appareil doivent être réalisées par des personnes compétentes et connaissant les textes et directives réglementaires, ainsi que les normes de référence telle que la norme EN60204.1.

Warnung!

de Die Installation und Wartungsarbeiten dieses Gerätes müssen durch eine Elektrofachkraft durchgeführt werden, nach den anerkannten technischen Regeln, Vorschriften und relevanten Normen z. B. EN 60204 Teil 1.

¡Advertencia!

es La instalación y mantenimiento de estos aparatos debe efectuarla un especialista, de acuerdo a las reglas, instrucciones y normas relevantes, p.ej.: EN60204, Parte 1.

Avvertenze!

it L'installazione e la manutenzione devono essere realizzate in accordo con le normative tecniche vigenti (esempio: EN60204-1) solamente da personale specializzato.

Varning!

sv Installation och underhåll av denna apparat får endast utföras av behörig person, och enligt gällande föreskrifter och standarder t.ex. EN 60204 del 1.

en Mounting kit for single mounting of electronic overload relay E45DU  
 fr Kit de montage indépendant pour relais électronique de surcharge E45DU  
 de Anbauteil für Einzelaufstellung für Elektronisches Überlastrelais E45DU  
 es Kit para Montaje separado del Relé de Sobrecarga electrónico E45DU  
 it Kit per il montaggio separato del relè elettronico di sovraccarico E45DU  
 sv Sockel för separat montering av Elektroniskt överlastrelä E45DU

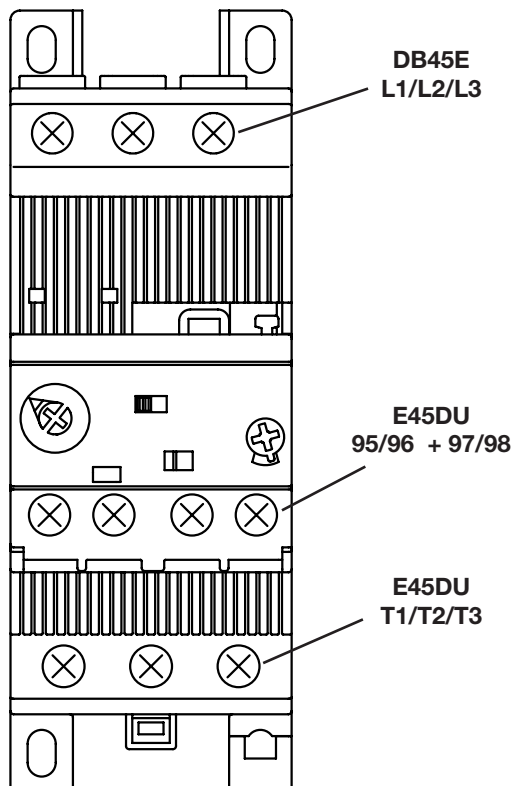
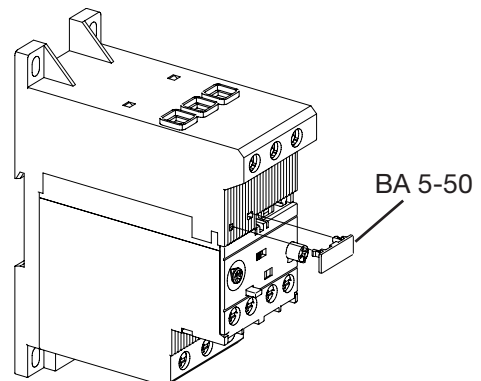

en Mounting position: as required  
 fr Position de montage: quelconque  
 de Einbaulage: beliebig  
 es Posición de montaje: cualquiera  
 it Posizione di montaggio: qualsiasi  
 sv Monteringsposition: valfri

	DB45E L1/L2/L3	E45DU 95/96 + 97/98	E45DU T1/T2/T3
	M5 Pozidriv 2 2.3 ... 2.6 Nm 20 lb.in	M3,5 Pozidriv 2 0.8 ... 1.0 Nm 7 lb.in	M5 Pozidriv 2 2.3 ... 2.6 Nm 20 lb.in
	1 x AWG 14 ... 6 1 x 2.5 ... 16 mm <sup>2</sup>	1 x AWG 16 ... 12 2 x AWG 16 ... 12 1 x 1.0 ... 4 mm <sup>2</sup> 2 x 1.0 ... 4 mm <sup>2</sup>	1 x AWG 14 ... 6 2 x AWG 14 ... 6 1 x 2.5 ... 16 mm <sup>2</sup> 2 x 2.5 ... 16 mm <sup>2</sup>
	1 x AWG 14 ... 8 1 x 2.5 ... 10 mm <sup>2</sup>	1 x AWG 18 ... 14 2 x AWG 18 ... 14 1 x 0.75 ... 2.5 2 x 0.75 ... 2.5	1 x AWG 14 ... 8 2 x AWG 14 ... 8 1 x 2.5 ... 10 mm <sup>2</sup> 2 x 2.5 ... 10 mm <sup>2</sup>

