



The Company

We are an established world force in the design and manufacture of instrumentation for industrial process control, flow measurement, gas and liquid analysis and environmental applications.

As a part of ABB, a world leader in process automation technology, we offer customers application expertise, service and support worldwide.

We are committed to teamwork, high quality manufacturing, advanced technology and unrivalled service and support.

The quality, accuracy and performance of the Company's products result from over 100 years experience, combined with a continuous program of innovative design and development to incorporate the latest technology.

The UKAS Calibration Laboratory No. 0255 is just one of the ten flow calibration plants operated by the Company and is indicative of our dedication to quality and accuracy.

EN ISO 9001:2000



Cert. No. Q 05907

EN 29001 (ISO 9001)



Lenno, Italy – Cert. No. 9/90A

Stonehouse, U.K.



0255

Electrical Safety

This equipment complies with the requirements of CEI/IEC 61010-1:2001-2 "Safety requirements for electrical equipment for measurement, control, and laboratory use". If the equipment is used in a manner NOT specified by the Company, the protection provided by the equipment may be impaired.

Symbols

One or more of the following symbols may appear on the equipment labelling:

	Warning – Refer to the manual for instructions		Direct current supply only
	Caution – Risk of electric shock		Alternating current supply only
	Protective earth (ground) terminal		Both direct and alternating current supply
	Earth (ground) terminal		The equipment is protected through double insulation

Information in this manual is intended only to assist our customers in the efficient operation of our equipment. Use of this manual for any other purpose is specifically prohibited and its contents are not to be reproduced in full or part without prior approval of the Technical Publications Department.

Health and Safety

To ensure that our products are safe and without risk to health, the following points must be noted:

1. The relevant sections of these instructions must be read carefully before proceeding.
2. Warning labels on containers and packages must be observed.
3. Installation, operation, maintenance and servicing must only be carried out by suitably trained personnel and in accordance with the information given.
4. Normal safety precautions must be taken to avoid the possibility of an accident occurring when operating in conditions of high pressure and/or temperature.
5. Chemicals must be stored away from heat, protected from temperature extremes and powders kept dry. Normal safe handling procedures must be used.
6. When disposing of chemicals ensure that no two chemicals are mixed.

Safety advice concerning the use of the equipment described in this manual or any relevant hazard data sheets (where applicable) may be obtained from the Company address on the back cover, together with servicing and spares information.

CONTENTS

1	INTRODUCTION	2	7	CALIBRATION	29
1.1	Description	2	7.1	Calibration Sequence	29
1.2	Training	2			
1.3	Location and Function of Main Components	2	8	MAINTENANCE	30
2	INSTALLATION	3	8.1	Chemical Solutions	30
2.1	Accessories	3	8.1.1	Reagent Solution	30
2.2	Location	3	8.1.2	Reference Electrode Filling Solution ..	30
2.3	Mounting	3	8.1.3	Standard Solutions	30
2.4	Sampling Requirement	3	8.2	Scheduled Servicing	30
2.5	Sample Connection	3	8.2.1	Regular Visual Checks	30
2.6	Connections, General	4	8.2.2	Four Weekly	30
2.7	External Electrical Connections	5	8.2.3	Twelve Monthly	31
2.8	Relay Contact Protection and Interference Suppression	6	8.2.4	Consumables Spares Kit	31
			8.2.5	Fitting the Electrodes	31
			8.2.6	Peristaltic Pump	32
			8.2.7	Replacement of Plumbing Tubing	32
3	SETTING UP	7	8.3	Shutdown Procedure	33
			8.3.1	Short Term	33
			8.3.2	Long Term	33
4	LIQUID HANDLING SECTION	8	8.4	Unscheduled Servicing	33
4.1	Principle of Operation	8	8.4.1	Malfunction of the Monitor	33
4.2	General Operation	8	8.4.2	Monitor Diagnostic Information	34
			8.4.3	Malfunction of the Electrode	34
5	ELECTRONICS SECTION	9	8.5	Reconditioning the Chloride Electrode	34
5.1	Electronic Layout	9	8.6	Microprocessor Unit Error Messages	35
5.2	User Junction Box	9			
5.3	Microprocessor Unit	9	9	SPECIFICATION	36
5.4	Front Panel Controls	10			
5.5	Displays	10	10	SPARES	37
5.6	L.E.D. Indication	10			
6	PROGRAMMING	11		APPENDIX A – REPLACING SOFTWARE EPROM	39
6.1	Normal Operation	12	A.1	Access the Transmitter Unit	39
6.2	Programming Pages	12	A.2	Access the PCB	39
6.2.1	Operating Page 1	13	A.3	Removing the PCB	39
6.2.2	Operating Page 2	14	A.4	Changing the EPROM	40
6.2.3	Security Code Page	15	A.5	Completing the Procedure	40
6.2.4	Set Up Input Page	16			
6.2.5	Current Output Page	17			
6.2.6	Set Up Alarms Page	20			
6.2.7	Set Up Clock Page	22			
6.2.8	Calibration User Code Page	24			
6.2.9	Set Up Temperature Control Page	25			
6.2.10	Electrical Calibration	25			
6.2.11	Electrical Calibration Page	26			

1 INTRODUCTION

1.1 Description

The Model 8235 Chloride Monitor is a microprocessor based analyser using a chloride ion-selective electrode in conjunction with a silver/silver chloride double junction reference electrode.

1.2 Training

Due to the specialised nature of the above instrument, it is recommended that, where the end users personnel have had no previous experience of maintaining this equipment, training be provided by this Company.

Such training is available via the local Company in the UK, or Overseas Agent elsewhere and may be carried out either on the users premises or at the factory.

1.3 Location and Function of Main Components – Fig. 1.1

Monitoring of chloride involves the addition of a reagent to the sample water so that measurement takes place in a solution of appropriate and effectively constant pH. Under these conditions the electrical potential developed between the chloride electrode and the reference electrode is proportional to the chloride ion concentration in the solution.

The 8235 chloride monitor has a liquid handling section in the lower half of a moulded plastic enclosure, and the electronics section in the upper portion.

Sample inlet and drain connections are at the base of the instrument. A peristaltic pump, mounted centrally, proportions sample and reagent through a heated mixing and reaction flowcell where the measurement takes place.

To maintain optimum measurement accuracy, it is necessary to carry out two point calibration by introducing 'low' and 'high' standard solutions of known concentration. The 8235 monitor uses solenoid valves to introduce these solutions automatically at programmable intervals under the control of the microprocessor.

Access to the electrodes, pump and calibration solution containers is by means of a hinged acrylic door, which is held open or closed by use of a push/push latch. The instrument case is also hinged to allow access to the electronics section and solenoid valves etc. for maintenance.

The electronics section consists of a microprocessor unit situated at the top left which controls the instrument functions, and a user junction box for all external electrical connections, at the top right behind the hinged case.

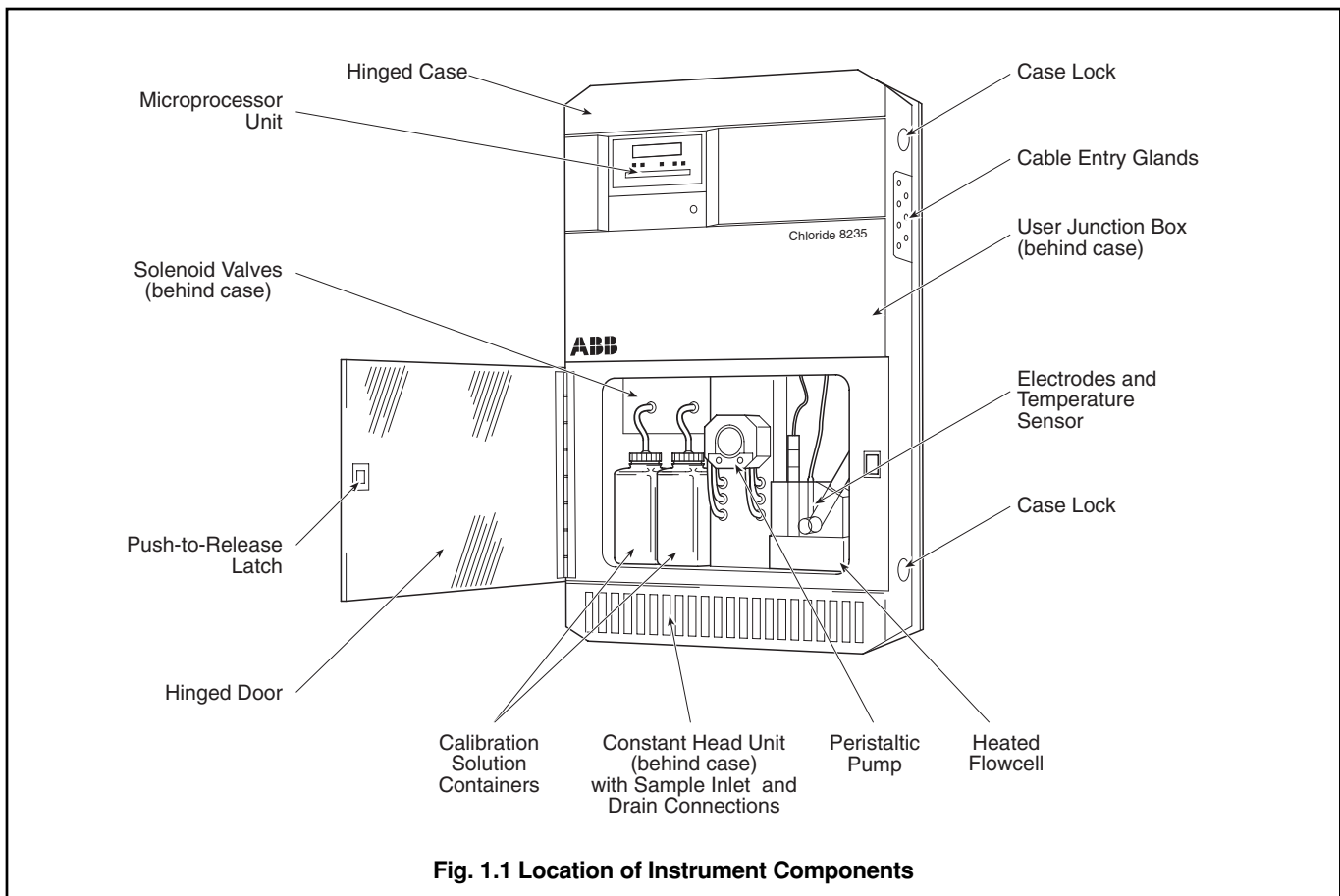

Fig. 1.1 Location of Instrument Components

2 INSTALLATION

2.1 Accessories

1 x reagent bottle	4 x calibration bottles
1 x chloride electrode	1 x spares kit
1 x silver/silver chloride reference electrode	

2.2 Location

The monitor should be installed in a clean, dry, well ventilated and vibration-free location giving easy access, and where short sample lines can be used. Rooms containing corrosive gases or vapours (e.g., chlorination equipment or chlorine gas cylinders) should be avoided. It is also advisable to have adjacent drains near ground level, so that the waste outlet from the monitor can be as short as possible, together with maximum fall. Power supplies should also be adjacent. Ambient temperature: within the range 5 to 40 °C.

2.3 Mounting – Fig. 2.1

The monitor has a moulded plastic case, mounted onto a flat metal panel. To provide access, the case is hinged on the left hand side and has two lockable catches on the right hand side to hold the case in position in normal operation.

One keyhole slot is provided at the top of the flat panel to provide easy mounting on a wall or framework. Two further fixing holes are provided at the bottom of the flat panel. All holes are designed to take bolts or studs.

Mains and signal cables are connected through cable glands in the user junction box on the right hand side with the exception of the optional serial interface which connects directly into the microprocessor unit. Sample and drain pipework are brought in through the bottom of the case.

2.4 Sampling Requirement

In addition to being as close as possible to the monitor, the sampling point must provide a thoroughly mixed representative sample. The sample must also conform to the following conditions:

- Sample flowrates must be between 5 ml min⁻¹ and 1250 ml min⁻¹.
- Sample temperature should be within 20 °C of the ambient temperature and within the range 0 to 40 °C.
- Particles must be less than 10 mg l⁻¹ and the size must not exceed 60 µm. Above these levels it is essential that a filter is fitted in the sample inlet.

2.5 Sample Connections – Fig. 2.2

The inlet and outlet pipe connections are both located at the bottom of the case. A 6 mm (1/4") hose adaptor is provided for the sample inlet and a 9 mm (3/8") hose connection for the drain. The inlet and outlet pipes should be of an inert, flexible material such as p.v.c. The inlet pipe must incorporate a shut-off valve at its upstream end, while the drain outlet pipe should be short, venting to atmosphere as soon as possible.

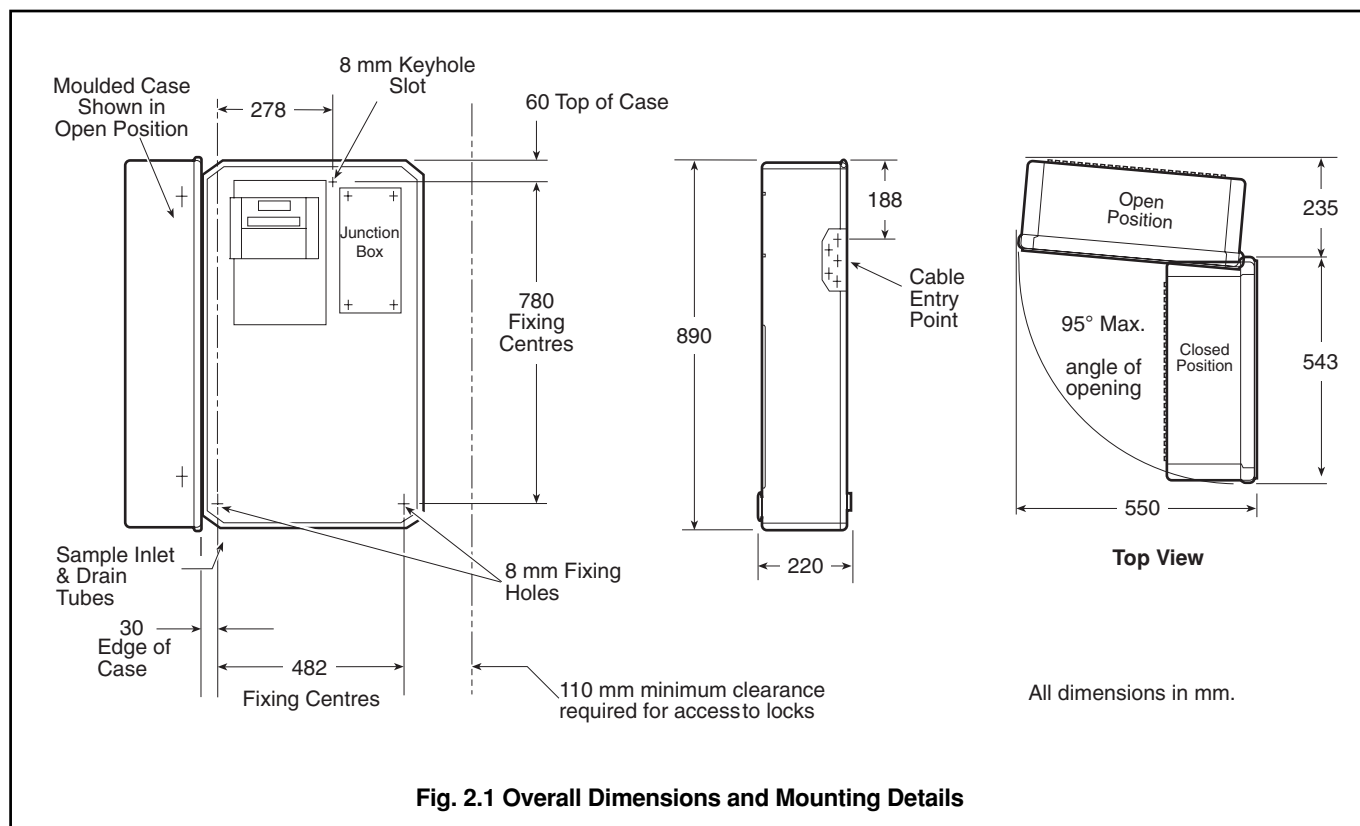

...2 INSTALLATION

2.6 Connections, General



Warnings.

- A disconnecting device such as a switch or circuit breaker conforming to local safety standards must be fitted to the final installation. It must be fitted in close proximity to the instrument within easy reach of the operator and must be marked clearly as the disconnection device for the instrument.
- Although certain instruments are fitted with internal fuse protection, a suitably rated external protection device, e.g. a 3A fuse or miniature circuit breaker (m.c.b.), must also be fitted by the installer.
- Remove all power from supply, relay and any powered control circuits and high common mode voltages before accessing or making any connections.
- The power supply earth (ground) **must** be connected to ensure safety to personnel, reduction of the effects of RFI interference and correct operation of the power supply interference filter.
- The power supply earth (ground) **must** be connected to the earth (ground) stud on the junction box case – see Fig. 2.3.
- Use cable appropriate for the load currents. The terminals accept cables up to 14AWG (2.5mm²).
- The instrument conforms to Mains Power Input Insulation Category III. All other inputs and outputs conform to Category II.
- All connections to secondary circuits must have basic insulation.
- After installation, there must be no access to live parts, e.g. terminals.
- Terminals for external circuits are for use only with equipment with no accessible live parts.
- The relay contacts are voltage-free and must be appropriately connected in series with the power supply and the alarm/control device which they are to actuate. Ensure that the contact rating is not exceeded. Refer also to Section 2.8 for relay contact protection details when the relays are to be used for switching loads.
- Do not exceed the maximum load specification for the selected analog output range.
The analog output is isolated, therefore the –ve terminal must be connected to earth (ground) if connecting to the isolated input of another device.
- If the instrument is used in a manner not specified by the Company, the protection provided by the equipment may be impaired.
- All equipment connected to the instrument's terminals must comply with local safety standards (IEC 60950, EN61010-1).

Notes.

- An earthing (grounding) – stud terminal is fitted to the junction box case for bus-bar earth (ground) connection – see Fig. 2.3.
 - Always route signal output and mains-carrying/relay cables separately, ideally in earthed (grounded) metal conduit. Use twisted pair output leads or screened cable with the screen connected to the case earth (ground) stud.

Ensure that the cables enter the analyzer through the glands nearest the appropriate screw terminals and are short and direct. Do not tuck excess cable into the terminal compartment.
 - Ensure that the IP65 rating is not compromised when using cable glands, conduit fittings and blanking plugs/bungs (M20 holes). The M20 glands accept cable of between 5 and 9mm (0.2 and 0.35 in.) diameter.
-

2.7 External Electrical Connections – Fig. 2.3

The external electrical connections are to be found in the user junction box with the exception of the optional serial interface which is connected directly into the microprocessor unit. The cables are passed through the cable glands on the right hand side of the junction box which are adjacent to the internal electrical terminals.

Caution. Slacken the terminal screws fully before making connections.

The connections are as follows:

- a) The mains voltage is selected by means of the voltage selector – see Fig. 2.3.
- b) Current outputs 1 and 2 – two independent current outputs for external recording or control. One output is supplied as standard, the second is supplied as an optional extra – see Fig. 2.4 for details regarding current output range.
- c) Relay 1 and 2 – two concentration alarms.
- d) Relay 3 – calibration mode indication. This indicates when the instrument is off line during a calibration.
- e) Relay 4 – instrument 'OUT OF SERVICE' indication. This indicates that the monitor readings are suspect and it is in need of attention.
- f) Relay 5 – 'OUT OF SAMPLE' – indication of loss of sample.
- g) Optional serial interface – connected into the Microprocessor Unit. See supplementary instruction manual for details

Information. Because the current output is isolated, the negative terminal **must** be connected to earth (ground) if connecting to the isolated input of another device.

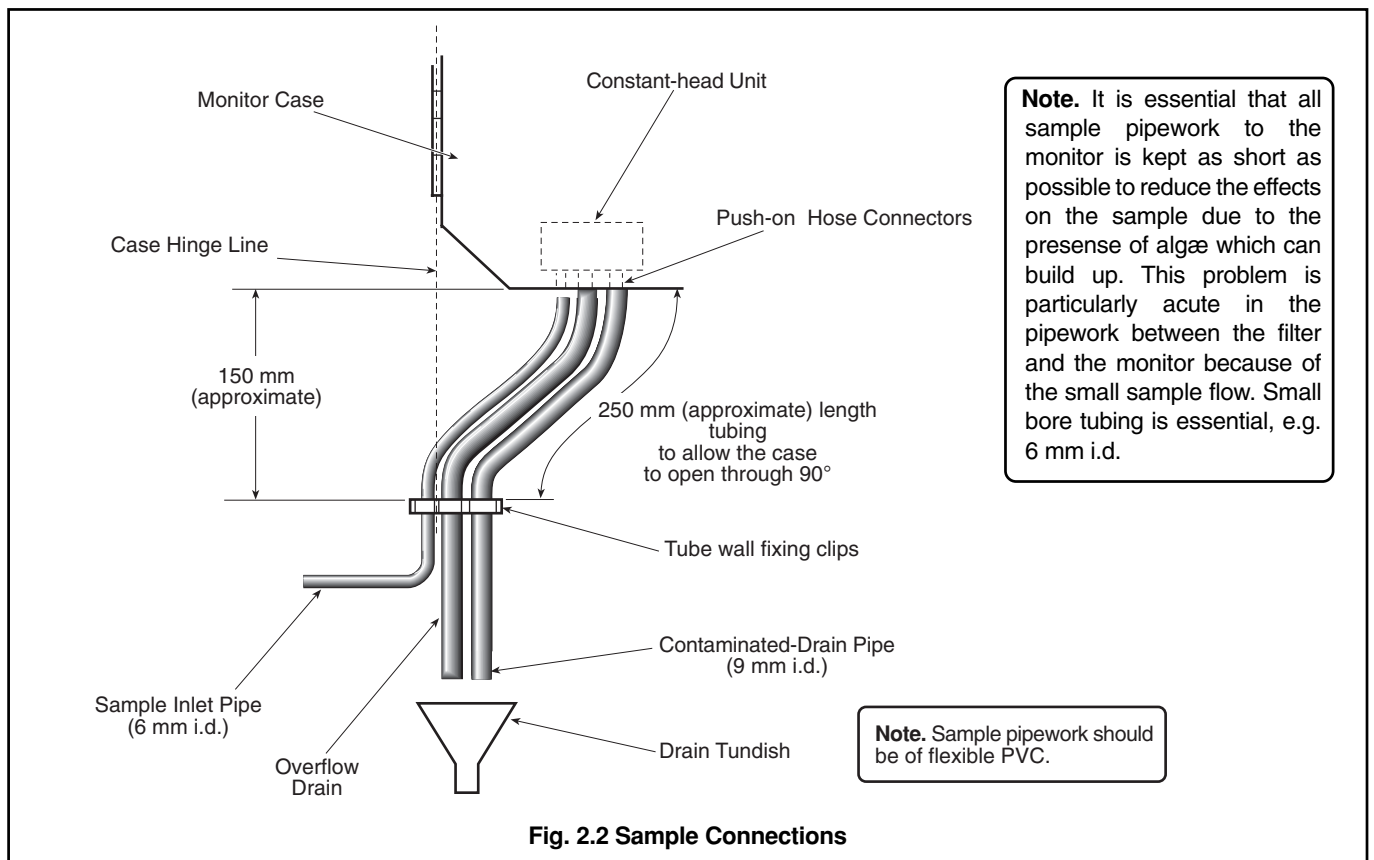

Fig. 2.2 Sample Connections

...2 INSTALLATION

2.8 Relay Contact Protection and Interference Suppression – Fig. 2.5

If the relays are used to switch loads on or off the relay contacts can become eroded due to arcing. Arcing also produces r.f.i. which can cause instrument malfunctions and incorrect readings. To minimize the effects of r.f.i., arc suppression components are required; these are resistor/capacitor networks for a.c. applications, or diodes for d.c. applications. These components can be connected either across the load or directly across the relay contacts.

For **a.c. applications** the value of the resistor/capacitor network depends on the load current and inductance that is switched. Initially fit a 100 R/0.022 μ F RC suppressor unit (part no. B9303)

as shown in Fig. 2.5A. If the instrument malfunctions the value of the RC network is too low for suppression and an alternative value must be used. If the correct RC suppressor unit cannot be obtained, contact the manufacturer of the switched device for details of the RC unit required.

For **d.c. applications** fit a diode as shown in Fig. 2.5B. For general applications use an alternative IN5406 type (600 V peak inverse voltage at 3 A – part number B7363).

Note. For reliable switching the minimum voltage must be greater than 12 V and the minimum current greater than 100 mA.

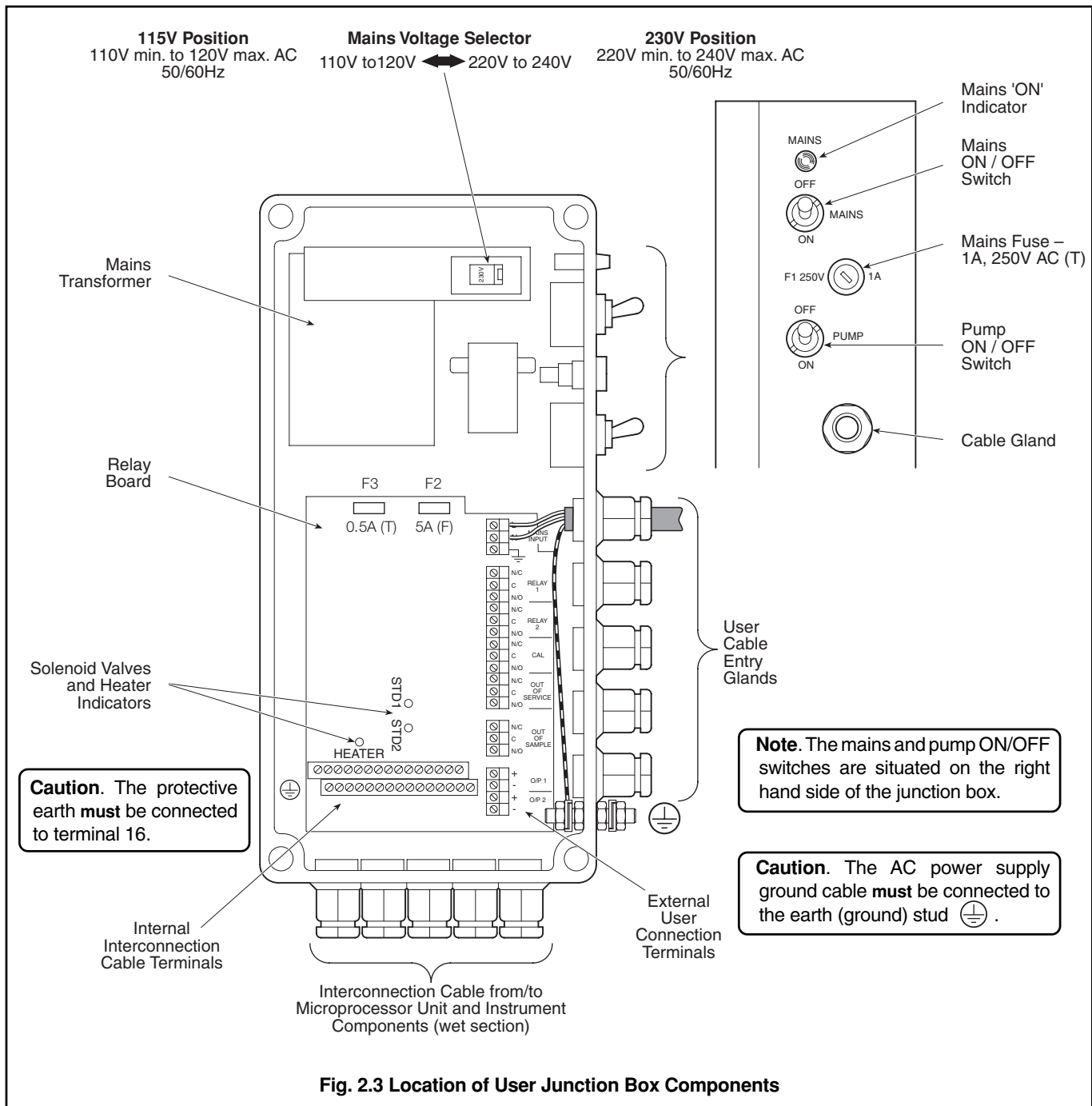

2 INSTALLATION

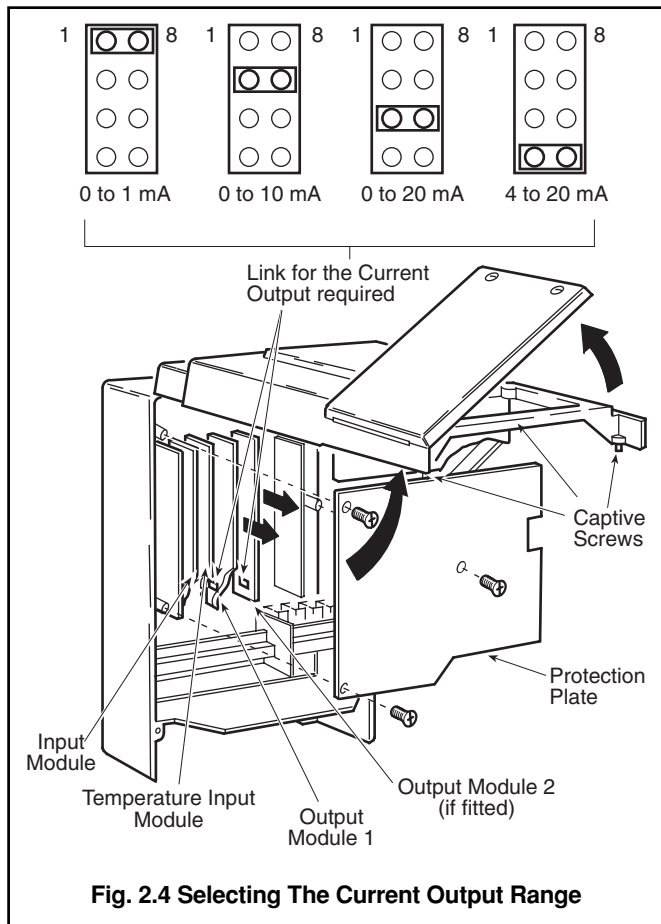

3 SETTING UP

Note. Before proceeding any further, ensure that all switches are set to OFF on the right hand side of the electronics unit – see Fig. 2.3.

- Ensure that all external electrical and plumbing connections have been made correctly.
- Fill reagent and standard solution bottles and connect them to the monitor. (See Section 8.1 for details of these solutions.)
- Fit the electrodes according to the instructions in Section 8.2.5.
- Connect the electrical supply and switch on.

Note. The temperature controlled flowcell requires up to half an hour to reach the normal control temperature of 35 °C. During this time, 'Temp. Control Error' is indicated on the display and any calibrations are prevented by the microprocessor.

- Verify that there is an adequate supply of sample to the monitor constant head unit.
- Fit the pump platen on the peristaltic pump (see Section 8.2.6) and turn on the pump with the switch on the side of the monitor. Note that the peristaltic pump rotates, and check that sample and reagents are being drawn into the monitor by observing the progress of any small bubbles present in the inlet tubes.
- Run the monitor for at least one hour to allow the temperature to stabilize, solutions to be pumped into the system and to purge the air from the pipework. Check for any leaks around the pipe connections and rectify as necessary.
- When the monitor reading has stabilized, carry out a calibration – see Programming Page.

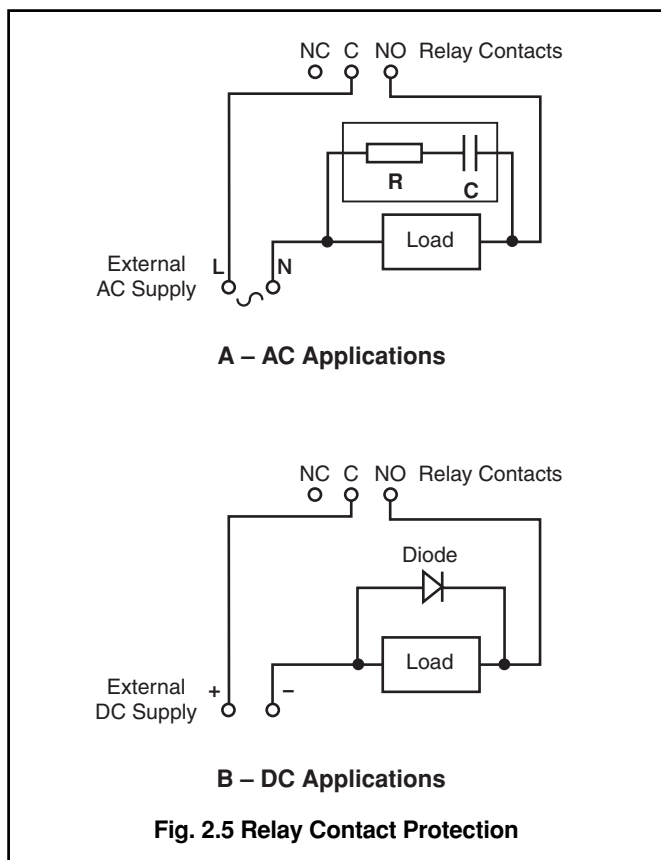

4 LIQUID HANDLING SECTION

4.1 Principle of Operation

The monitor uses an ABB Chloride Ion-selective Electrode in conjunction with a silver/silver chloride reference electrode. The sensing tip of the chloride electrode is a chloridised silver billet. The electrode is connected to the main electronic unit via a screened cable. When the electrode is in contact with a sample chloride solution, a potential is developed between it and the reference electrode which is proportional to the chloride ion concentration.

The electrochemical cell is completed by the reference electrode, which generates a stable reference potential and is also connected to the main electronic unit. It comprises a reference element in a salt bridge container which is in contact with an outer electrolyte via a porous ceramic junction. The outer junction then contacts the sample via another ceramic junction. This double junction arrangement protects the inner element from contamination.

Range of measurement can be set to any two consecutive decades of concentration between 2.0 and 5000 mg l⁻¹ chloride (Cl⁻).

Under typical circumstances, with appropriate standard solutions and calibration frequencies, accuracies better than ±5% of reading or ±0.05 mg l⁻¹ whichever is the greater, can be achieved.

4.2 General Operation – Fig. 4.2

The sequence of events is:

- The sample enters the constant head unit from below and any excess is allowed to overflow to drain.

The constant head unit is fitted with a float switch to signal an 'Out of Sample' condition. This switch is used by the monitor to initiate the 'Out of Sample' alarm.

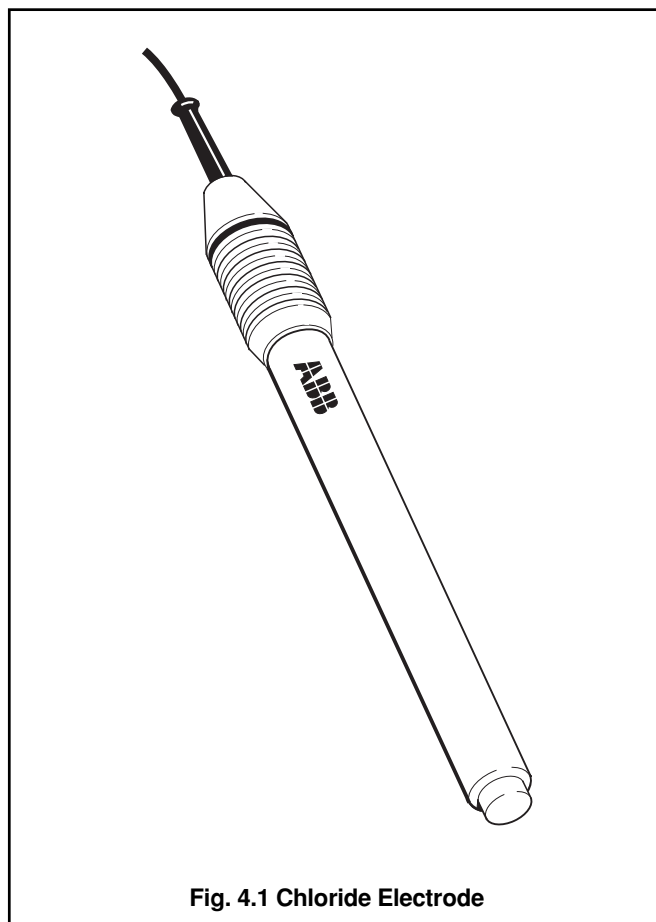

Fig. 4.1 Chloride Electrode

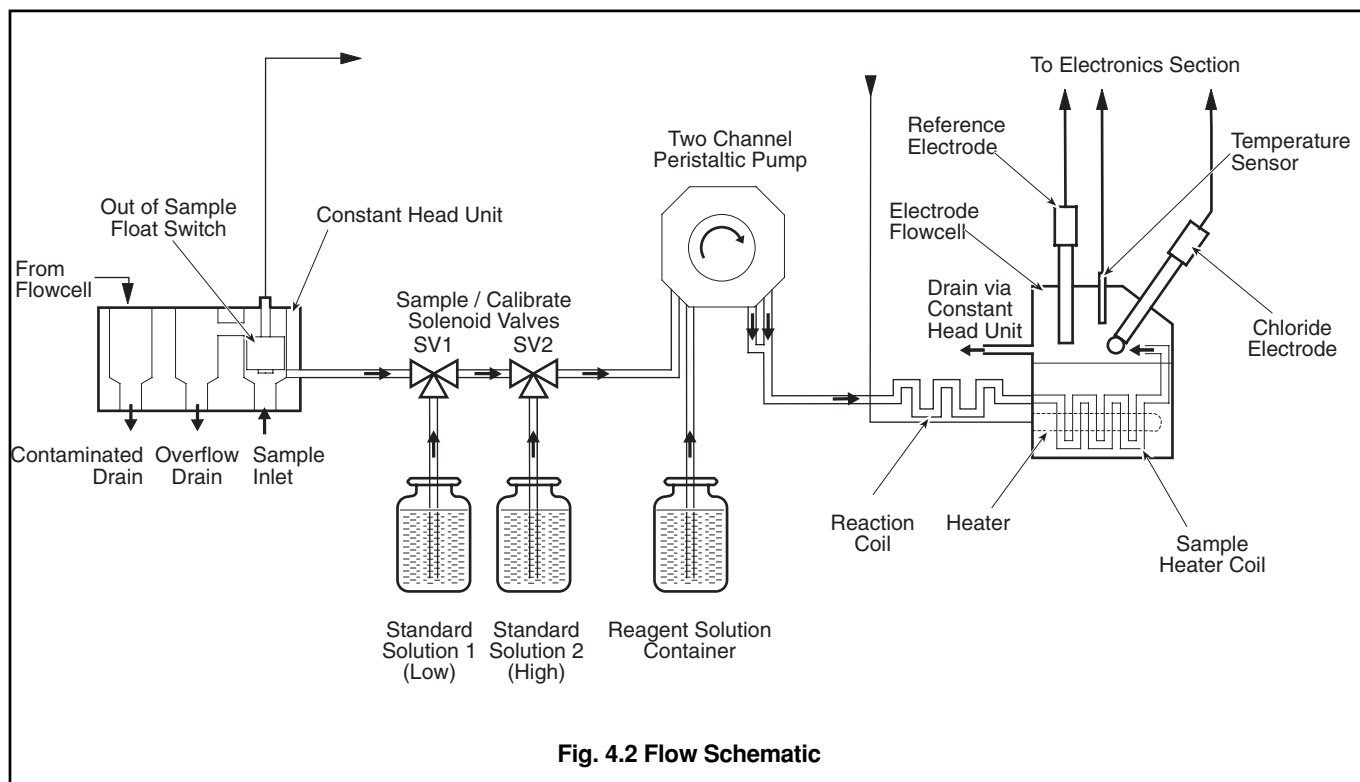

Fig. 4.2 Flow Schematic

4 LIQUID HANDLING SECTION

- b) From the bottom of the constant head unit the sample is drawn through the normally open ports of the solenoid valves SV1 and SV2 by one channel of the peristaltic pump.
- c) The reagent is drawn through another channel of the peristaltic pump, and is then mixed with the sample. The tube diameters are arranged so as to obtain the correct ratio of sample and reagent.
- d) The electrodes are housed in a temperature controlled flowcell which includes a heat exchanger to remove the effects of sample and ambient temperature variations. The electrodes produce an electrical potential when exposed to the reacted sample, which is proportional to the concentration of the ion being measured. The electrodes are connected to the electronic section where, after digital conversion, the signal is processed by the microprocessor.
- e) After measurement the sample flows to waste via the contaminated drain connection.
- f) During calibration the monitor introduces two calibration solutions sequentially in place of the sample by means of the solenoid valves SV1 and SV2.

5 ELECTRONICS SECTION

5.1 Electronic Layout – Fig. 5.1

The electronic section comprises two separate sections:

- The User Junction Box at the top right hand side.
- The Microprocessor Unit at the top left hand side.

5.2 User Junction Box

This unit contains the relays for the heater, solenoid valves and alarms, and all the user external connection terminals, with the exception of the serial interface (if fitted).

Once installed there should be no need to remove the junction box cover on a regular basis. However, to assist in any fault finding procedure, there are light emitting diodes (l.e.ds) on the printed circuit board (p.c.b.) to indicate if the relays and heater are being energised.

Switches for the mains and pump/heater are situated on the right hand side of the junction box, together with a mains indication lamp and mains fuse – see Fig. 2.3.

Two additional fuses (F2 and F3) are located within the junction box. These are connected in the 24V AC circuits.

5.3 Microprocessor Unit

This contains the analogue input processing, microprocessor, alarm and current output generation, and (if fitted) the serial interface output.

The programme controls, digital and dot-matrix displays, alarm indication and status l.e.ds are all mounted on the front panel of the microprocessor unit.

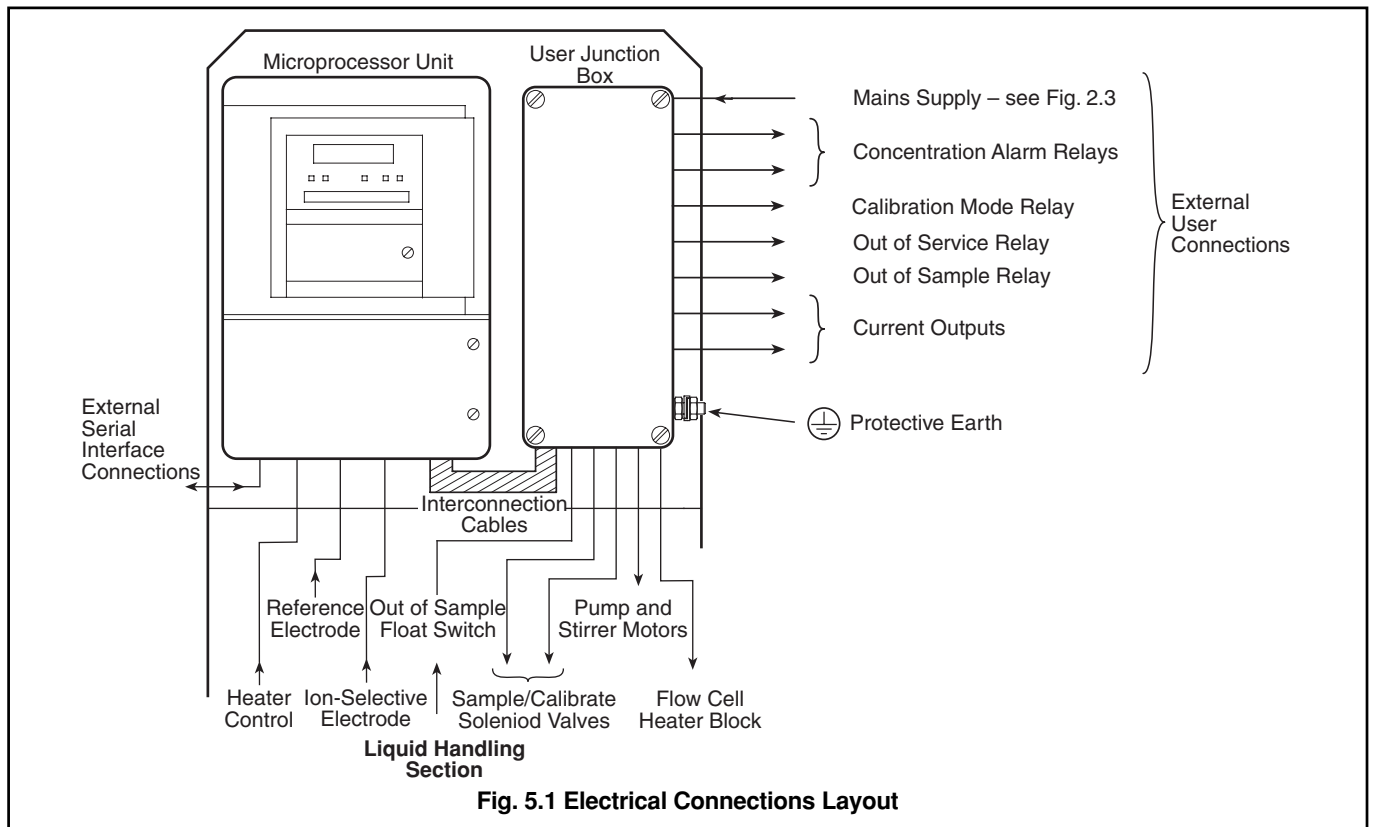

Fig. 5.1 Electrical Connections Layout

...5 ELECTRONICS SECTION

5.4 Front Panel Controls – Fig. 5.2

The programme controls comprise eight tactile membrane switches. These switches are situated behind a hinged door below the display, access is via a screwdriver-operated catch. In normal operation the switches are used to view the measured ion concentration value, initiate a manual calibration, or to activate the 'alarm hold' facility.

When programming, the switches are used to sequence through a programming procedure as detailed. The procedure is set out in programming pages for Input, Current Output, Alarms, Real Time Clock and Monitor Calibration. Each programme page contains the programme functions, the values or parameters of which are programmable.

Switch functions are as follows:

Mode

Used for viewing the chloride concentration, electrode mV output, flowcell control temperature, electrode slope, date, time, the day of the next calibration and the date of the last calibration.

Cal

Used to enable or disable the automatic calibrations, enter the standard solution values and manually initiate a calibration sequence. Operating 'Cal' during a calibration aborts the sequence and returns to normal operation.

Hold

Used to inhibit any change in the alarm relay/l.e.d. status and the start of any auto calibration. The feature is used during maintenance ('Hold' l.e.d. illuminated).

Note. If the 'Hold' facility is inadvertently left switched in, it is automatically cancelled after a period of approximately 3 hours has elapsed.

Enter

Used for storing the programmed function parameters and values in the instrument's nonvolatile memory.

Note. The instrument responds instantly to any programme change but the new value is lost in the event of a power interruption if it has not been 'Entered'.



Parameter Advance – used for selecting a particular parameter from a programme page.



Used for increasing or decreasing a parameter value or stepping up or down through a selection of parameters applicable to a particular function.



Note. Continued pressure on the 'Raise' or 'Lower' switches causes the rate of change of the displayed value to increase. To make small adjustments, operate the switches momentarily.



Page Advance – used, via the security code, for selection of individual programme pages.

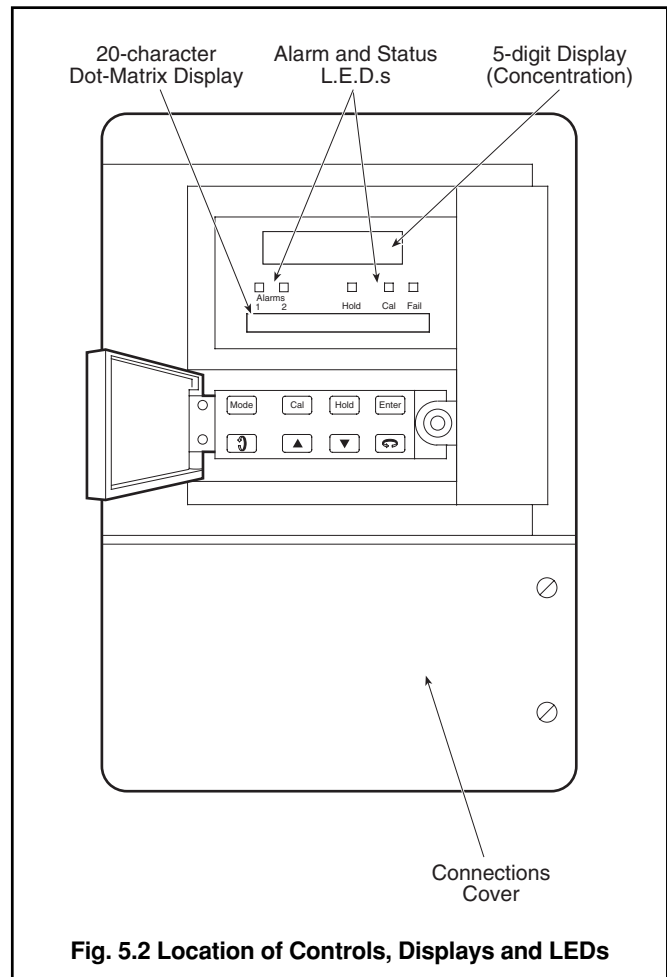

Fig. 5.2 Location of Controls, Displays and LEDs

5.5 Displays – Fig. 5.2

Two blue vacuum fluorescent displays are provided:

- The upper is a 5-digit 7-segment type display which indicates the measured variable.
- The lower is a 20-character dot matrix type which provides user information during setting up and in normal operation.

5.6 L.E.D. Indication – Fig. 5.2

There are 5 l.e.ds (indicators situated between the two displays) which provide information on the current status of the monitor. From left to right the indicators are as follows:



A1 or A2 Used to indicate a concentration alarm state (either high or low). This indicator is used in association with an external alarm relay output.



Hold Used to indicate that the 'Hold' button has been operated.



Cal Indicates when a calibration sequence is taking place.



Fail Indicates that the monitor was unable to carry out a successful calibration.

6 PROGRAMMING

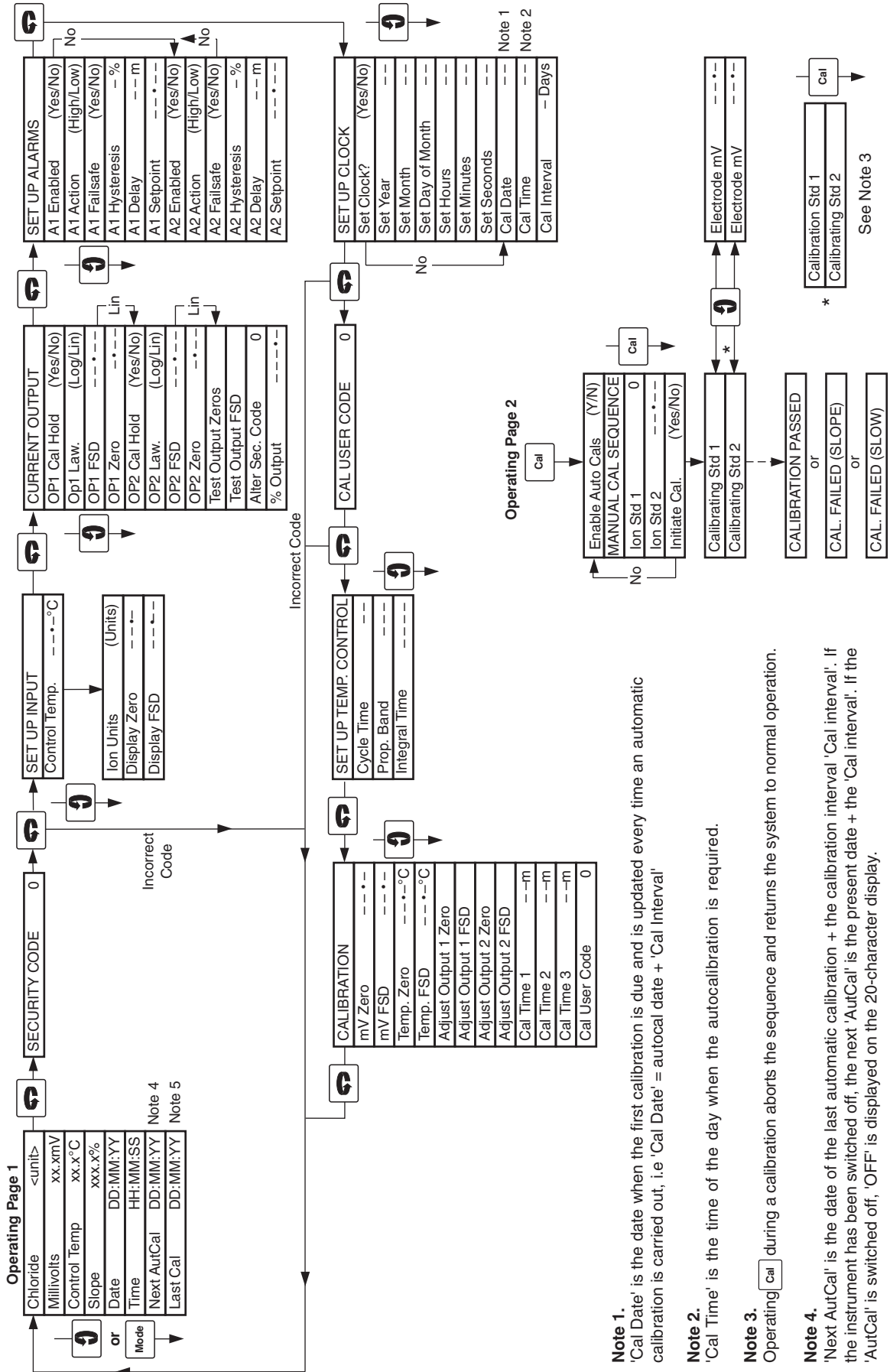





- Note 1.** 'Cal Date' is the date when the first calibration is due and is updated every time an automatic calibration is carried out, i.e. 'Cal Date' = autocal date + 'Cal Interval'
- Note 2.** 'Cal Time' is the time of the day when the autocalibration is required.
- Note 3.** Operating [Cal] during a calibration aborts the sequence and returns the system to normal operation.
- Note 4.** 'Next AutCal' is the date of the last automatic calibration + the calibration interval 'Cal interval'. If the instrument has been switched off, the next 'AutCal' is the present date + the 'Cal interval'. If the 'AutCal' is switched off, 'OFF' is displayed on the 20-character display.
- Note 5.** 'Last Cal' is the date of the last automatic or manual calibration.

Fig. 6.1 Overall Programming Chart





...6 PROGRAMMING

6.1 Normal Operation

In normal operation (Operating Page 1) the lower, dot matrix, display gives indication of the units of measurement, millivolt value, sensor slope and time. Selection is made using the  switch. Operation of the  switch gives access to a second Operating Page (Operating Page 2) in which the standard solution values can be set and a manual calibration can be initiated. Either page can be selected at any time by using the  or  switches.

6.2 Programming Pages

Operation of the  switch enables a series of 'programming' pages to be displayed. Unauthorised entries to this page are inhibited by a 5-digit security code which is displayed immediately after the page header.

In the programming pages, displayed values indicated 'xxxxx' are for viewing only and cannot be altered by the operator. Displayed values indicated '- - -' can be altered using the  and  switches. When the desired reading is displayed, operate the  switch. The LEDs flash momentarily, to indicate that the value has been stored in the nonvolatile memory. Although the instrument operates satisfactorily if the  switch is not operated, in the event of power interruption, the new values are lost. When power is applied again, the previously 'entered' values are restored. If previously programmed values are to be viewed only, it is unnecessary to operate the  switch.

6.2.1 Operating Page 1

The values displayed in Operating Page 1 are for viewing only and cannot be altered in this page.

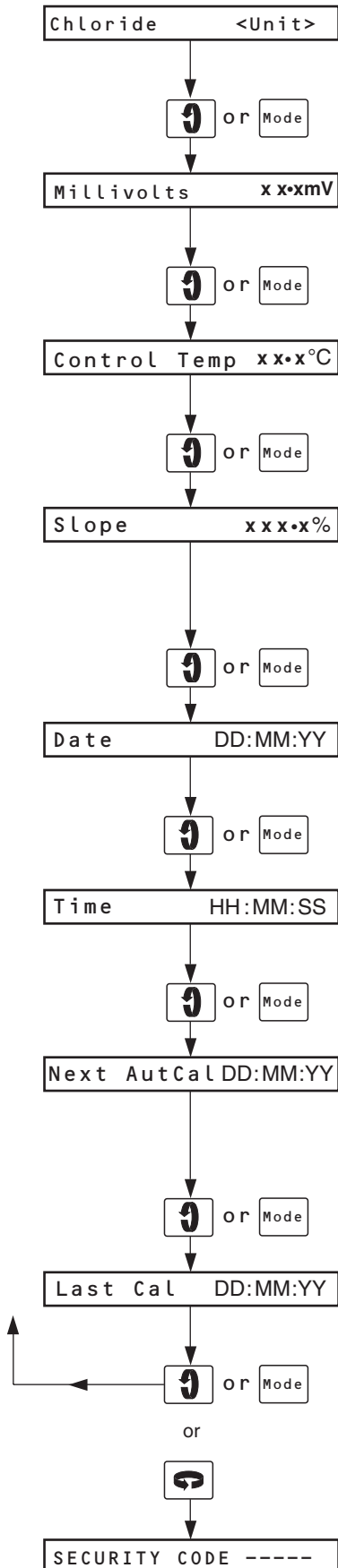

Measurement Units

The measurement units are displayed: Chloride mg l⁻¹ .

Advance to next parameter.

Sensor Output

The electrode output is displayed in millivolts.

Advance to next parameter.

Control Temperature

The measured flowcell temperature is displayed in degrees Celsius.

Advance to next parameter.

Slope Check Value

The slope value should be between 80 and 110%. If the value is outside these limits check the electrode.

Advance to next parameter.

Date

The date is displayed.

Advance to next parameter.

Time

The time is displayed.

Advance to next parameter.

Next Calibration Date

The date when the next automatic calibration is to be carried out is displayed. If the automatic calibration is disabled, 'OFF' is displayed in place of the date.

Advance to next parameter.

Last Calibration Date

The date of the last automatic or manual calibration is displayed.

Return to top of **Operating Page**.

or

Advance to **Security Page** (Section 6.2.3).

...6 PROGRAMMING

6.2.2 Operating Page 2

To gain access to the Calibration Page (Operating Page 2), operate the Cal switch.

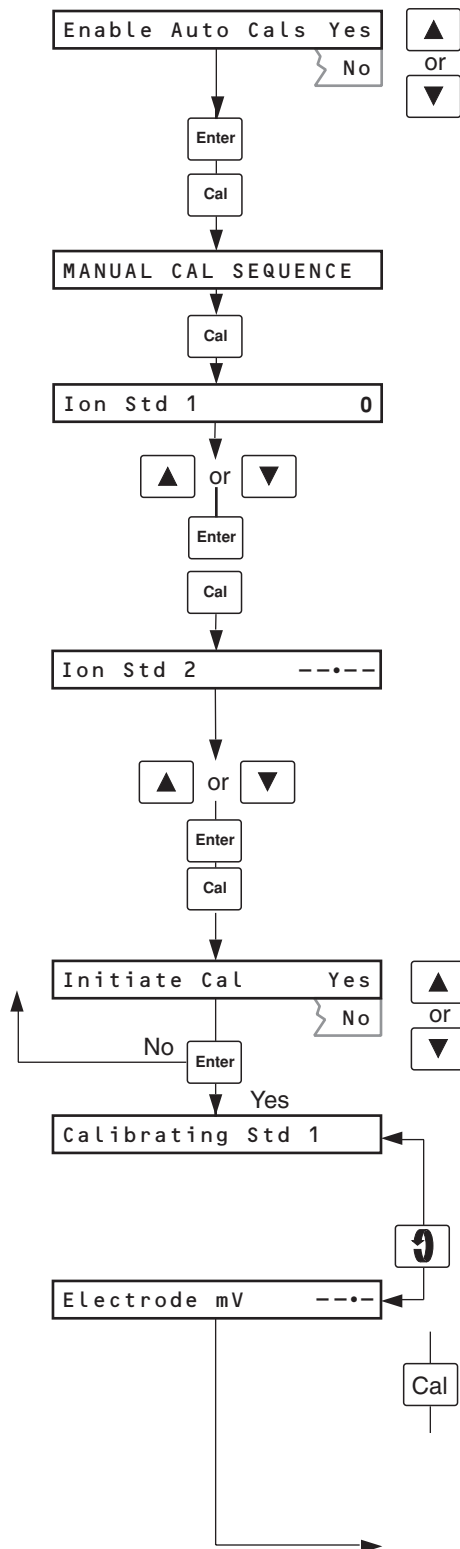

Enable Automatic Calibrations

Select 'Yes' to enable or 'No' to disable the automatic calibrations.

Store.

Advance to next parameter.

Page header.

Advance to next parameter.

Ion Standard 1

Set the value of the 'Low' standard solution (Std 1).

Store.

Advance to next parameter.

Ion Standard 2

Set the concentration value of the 'High' standard solution (Std 2). The concentration of the two standard solutions must differ from each other by a factor of at least four.

Store.

Advance to next parameter.

Initiate Calibration (manual)

Select 'Yes' to carry out a manual calibration or 'No' to return to the top of the page.

Enter must be pressed to initiate a manual calibration.

Calibrating Standard 1

The upper display shows the Chloride concentration value. The lower display remains until a stable output is obtained from the electrodes.

Toggle between the two lower displays.

Electrode Millivolts

The electrode output can also be displayed during calibration.

Note. Pressing Cal during a calibration aborts the sequence and returns to normal operation.

When a stable output is detected the lower display automatically advances to the next parameter, and the upper display is updated to the value of "Std 1".

Continued on next page.

...6.2.2 Operating Page 2
Continued from previous page.

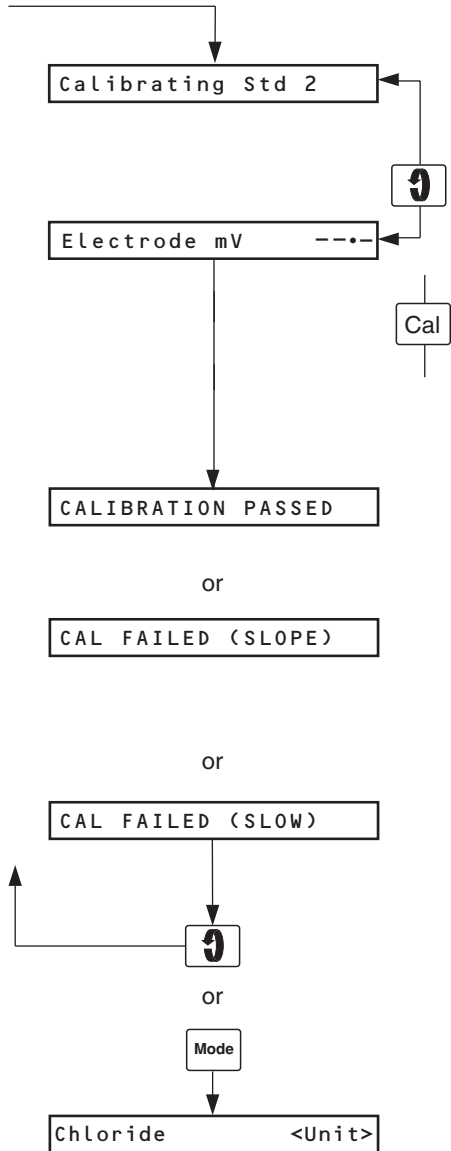

Calibrating Standard 2

The upper display shows the chloride concentration value based on the previous good calibration figures. The lower display remains until a stable output is obtained from the electrodes.

Toggle between the two lower displays.

Electrode Millivolts

The electrode output can also be displayed during calibration

Note. Pressing **Cal** during a calibration aborts the sequence and returns to normal operation.

When a stable output is detected the display automatically advances to the next parameter, and the upper display is updated to the value of "Std 2".

Calibration Passed

A satisfactory calibration has been carried out.

or

Calibration Failed (slope)

The monitor was unable to obtain an acceptable slope value during calibration. The slope value required is 80 to 110%.

or

Calibration Failed (slow)

The monitor was unable to obtain a stable output from the electrodes during calibration.

Return to top of **Operating Page 2**.

or

Return to **Operating Page 1**.

6.2.3 Security Code Page

A security code is required to gain access to all subsequent programming pages. The code is preset at the factory to '0' but can be changed if required in the Current Output Page – see Section 6.2.5.

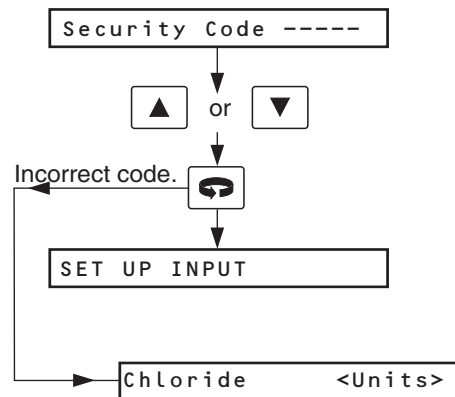

Security Code

Set the correct security code.

Advance to the first of the programming pages – **Set Up Input Page**.

Return to **Operating Page 1**.

...6 PROGRAMMING

6.2.4 Set Up Input Page

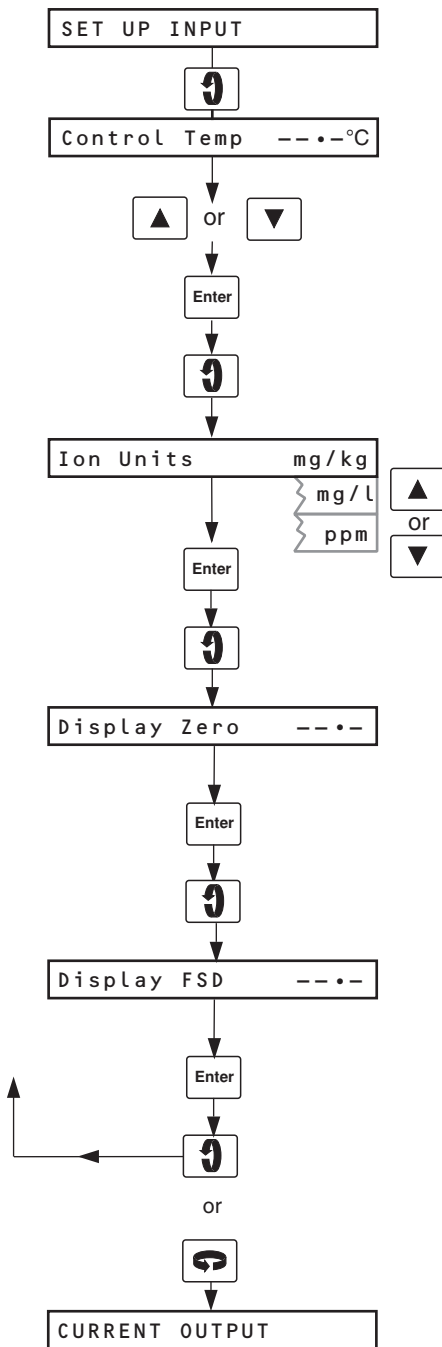

Page header.

Advance to next parameter.

Control Temperature

Set the required block control temperature within the range 5 to 45°C in 0.1°C increments.

Store.

Advance to next parameter.

Ion Units

Select the required display units for chloride concentration.

Store.

Advance to next parameter.

Display Zero

Select the required value for display (either 2.0, 5.0 or 10 mg l⁻¹ chloride).

Store.

Advance to next parameter.

Display Full Scale

The full scale value is automatically set at two decades above **Display Zero**.

Example– If the setting is 2.0 the full scale is automatically set to 200.0.

Store.

Return to top of **Set Up Input Page**.

or

Advance to **Current Output Page**.

6.2.5 Current Output Page

The current output is assigned to the chloride concentration but is only operative if the relevant output modules are fitted – see Fig. 2.4.

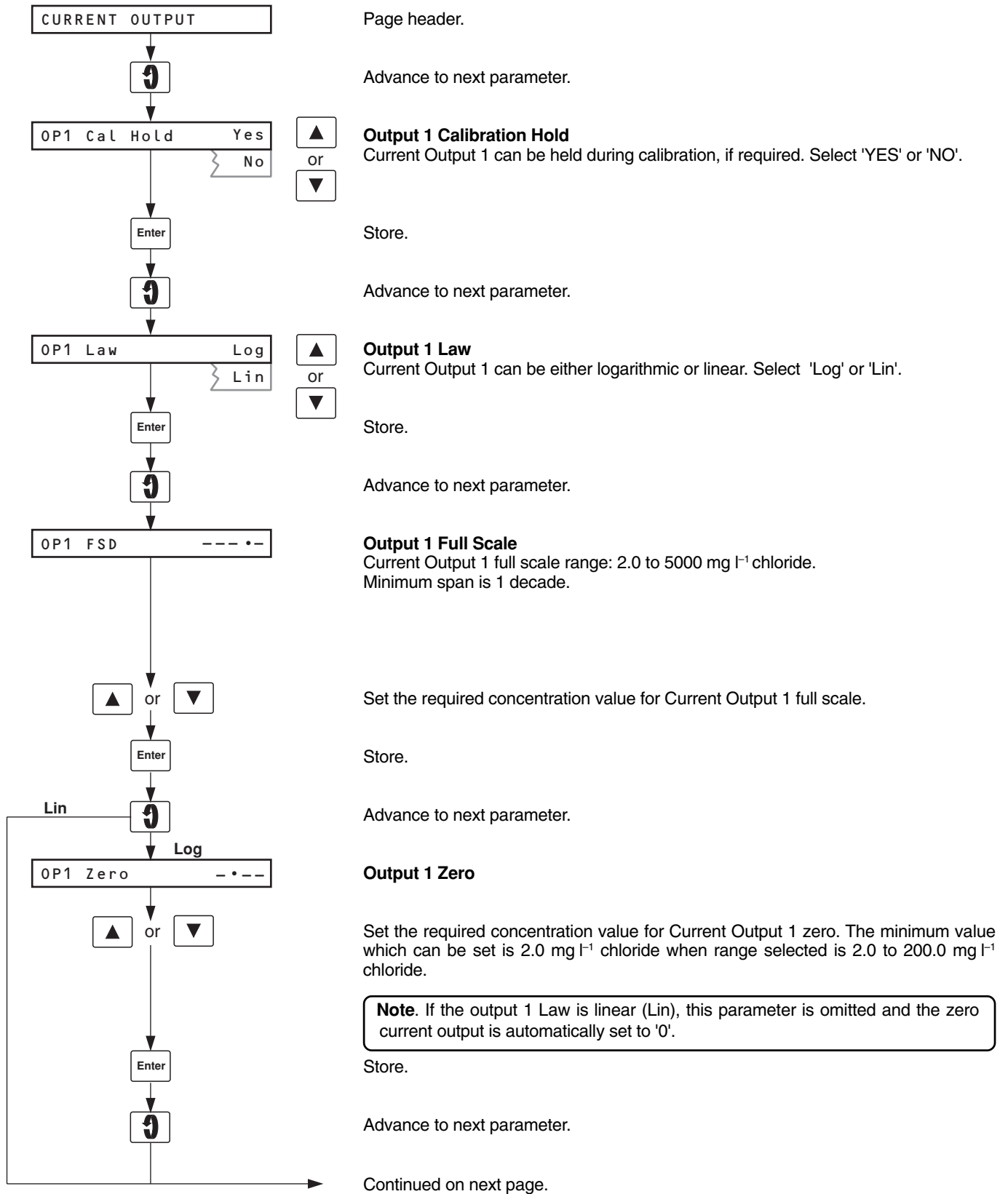

...6 PROGRAMMING

...6.2.5 Current Output Page Continued from previous page.

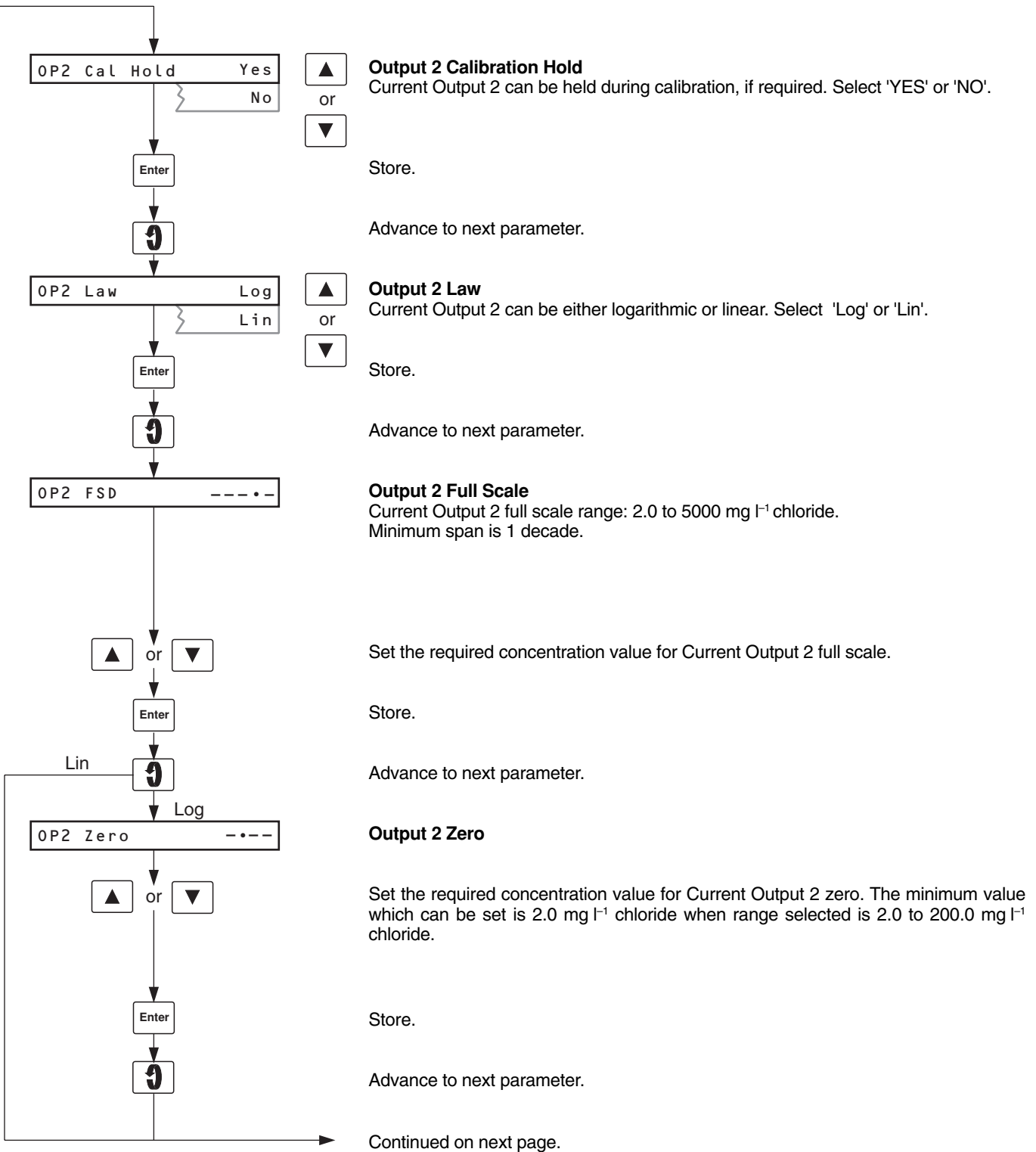

...6.2.5 Current Output Page

Continued from previous page.

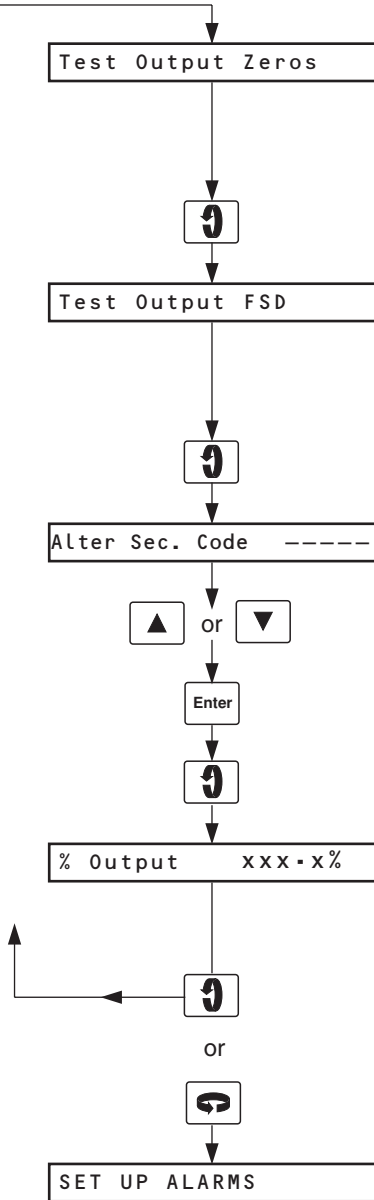

Test Current Output Zeros

The instrument automatically transmits a current output zero test signal on both outputs.

Example – For a 4 to 20 mA current output range, 4 mA is transmitted.

Advance to next parameter.

Test Current Output Full Scale

The instrument automatically transmits a current output full scale test signal on both outputs.

Example – For a 4 to 20 mA current output range, 20 mA is transmitted.

Advance to next parameter.

Alter Security Code

Set the Security Code required, between 0 and 19999. This value must then be entered again to access the secure parameters from Operating Page 1.

Store.

Advance to next parameter.

Proportional Output Percentage (to heater)

Used as a diagnostic check to indicate the proportionally controlled current output (%) to the heater.

Return to top of **Current Output Page**.

or

Advance to **Set Up Alarms Page**.

...6 PROGRAMMING

6.2.6 Set Up Alarms Page

Alarm l.e.d. indication and relay output can be assigned either to the chloride concentration or switched off.

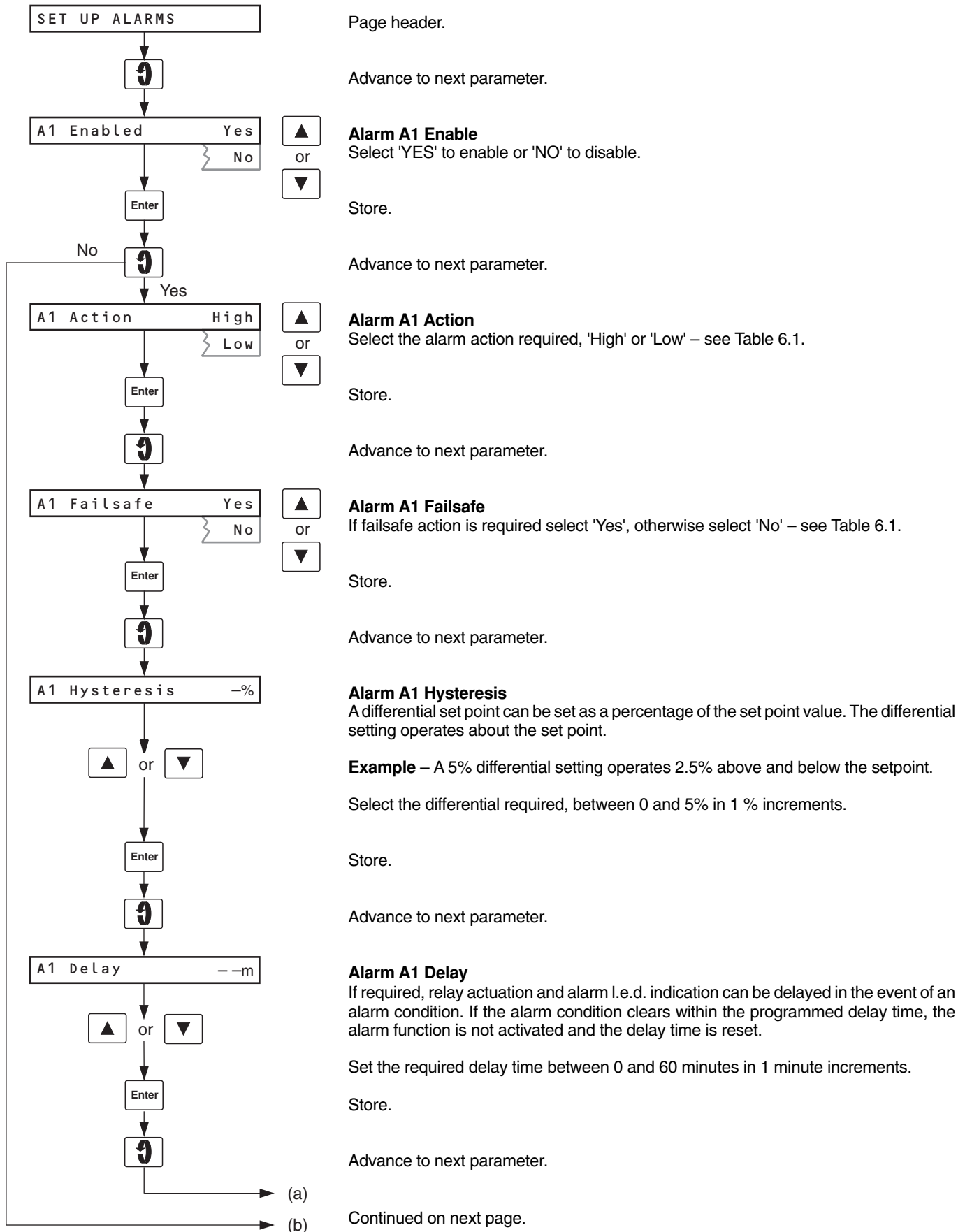

...6.2.6 Set Up Alarms Page

Continued from previous page.

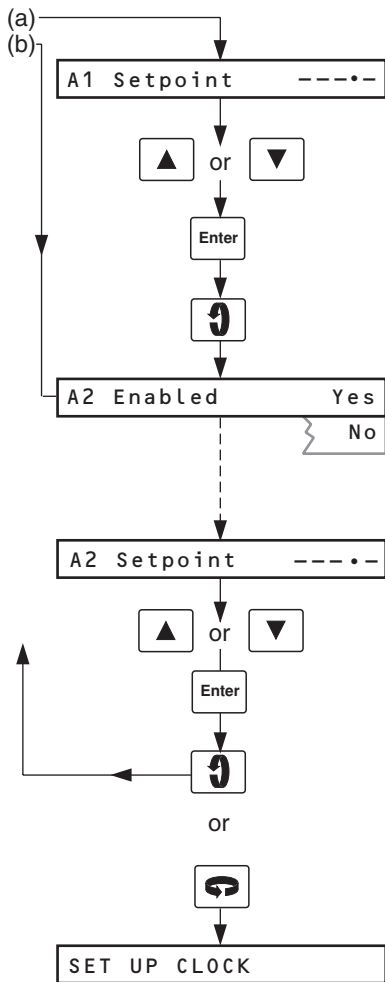

A1 Setpoint

Set the required setpoint value.

Store.

Advance to next parameter.

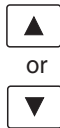

A2 Enabled

Repeat the programming procedures as for Alarm Relay 1.

A2 Setpoint

Set the required set point value.

Store.

Return to top of **Set Up Alarms Page**.

or

Advance to **Set Up Clock Page**.

Action	Failsafe	Measured Value	Relay Status	L.E.D. Indication
High	YES	Above Setpoint	De-energised	Flashing
		Below Setpoint	Energised	Off
High	NO	Above Setpoint	Energised	Flashing
		Below Setpoint	De-energised	Off
Low	YES	Above Setpoint	Energised	Off
		Below Setpoint	De-energised	Flashing
Low	NO	Above Setpoint	De-energised	Off
		Below Setpoint	Energised	Flashing

Table 6.1 Relay Action and Alarm Indication

6.2.7 Set Up Clock Page

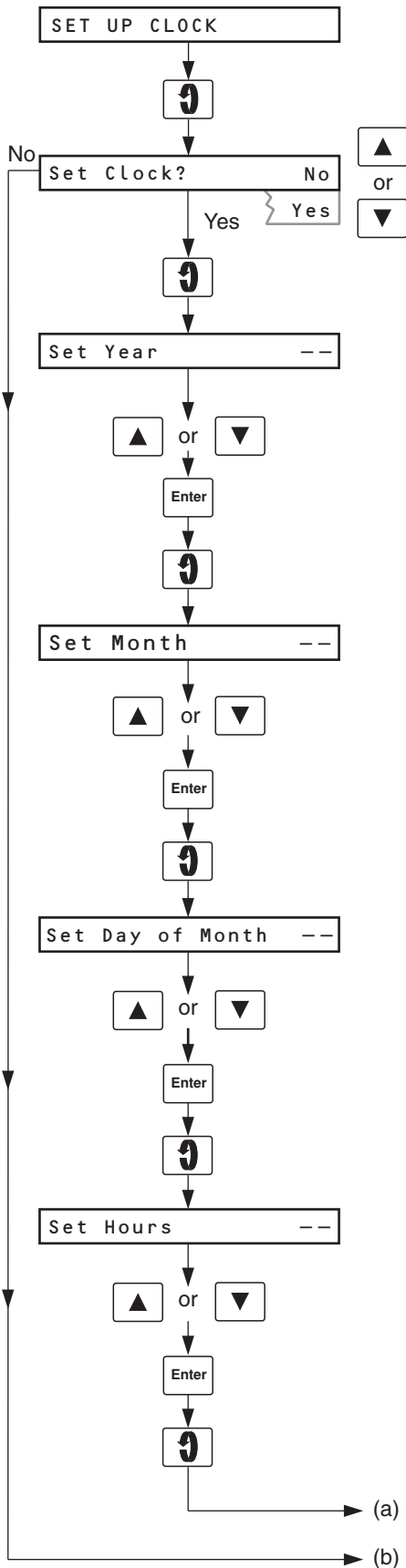

Page header.

Advance to next parameter.

Set Up Real Time Clock

Select 'Yes' to set up the clock, otherwise select 'No'.

Advance to next parameter.

Set Year

Set the appropriate year.

Store.

Advance to next parameter.

Set Month

Set the appropriate month.

Store.

Advance to next parameter.

Set Day

Set the appropriate day of the month.

Store.

Advance to next parameter.

Set Hours

Set the appropriate hour – (24 hour clock).

Store.

Advance to next parameter.

Continued on next page.

...6.2.7 Set Up Clock Page

Continued from previous page.

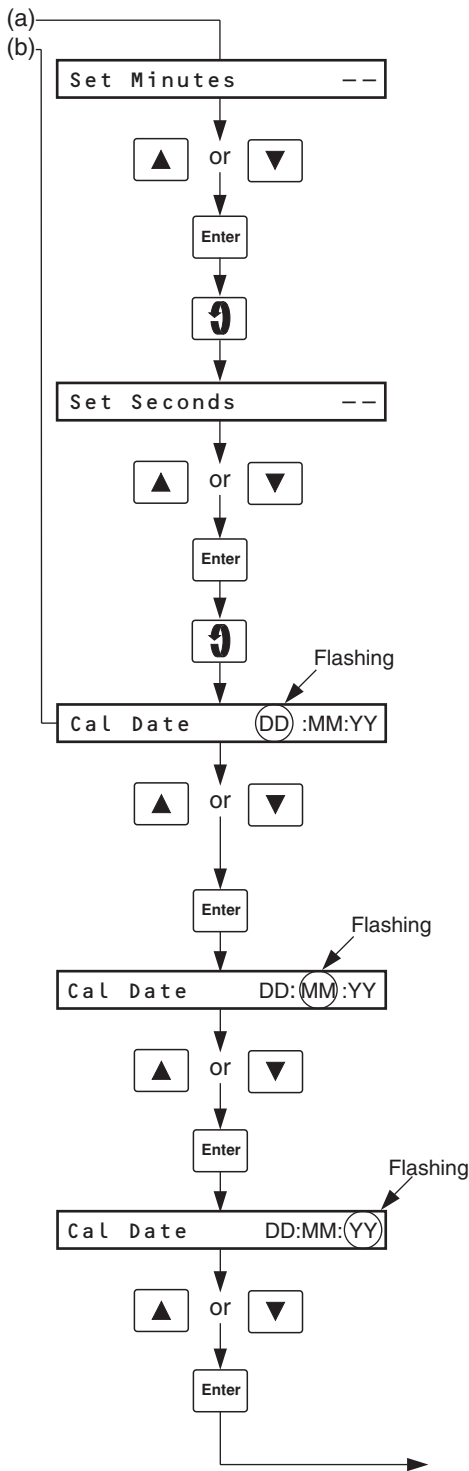

Set Minutes

Set the appropriate minutes.

Store.

Advance to next parameter.

Set Seconds

Set the appropriate seconds.

Store.

Advance to next parameter.

Calibration Date (day of the month)

Set the day of the month when the first automatic calibration is to be carried out.

Store and advance to next parameter.

Calibration Date (month)

Set the month when the first automatic calibration is to be carried out.

Store and advance to next parameter.

Calibration Date (year)

Set the year when the first automatic calibration is to be carried out.

Store and advance to next parameter.

Continued on next page.

...6 PROGRAMMING

...6.2.7 Set Up Clock Page

Continued from previous page.

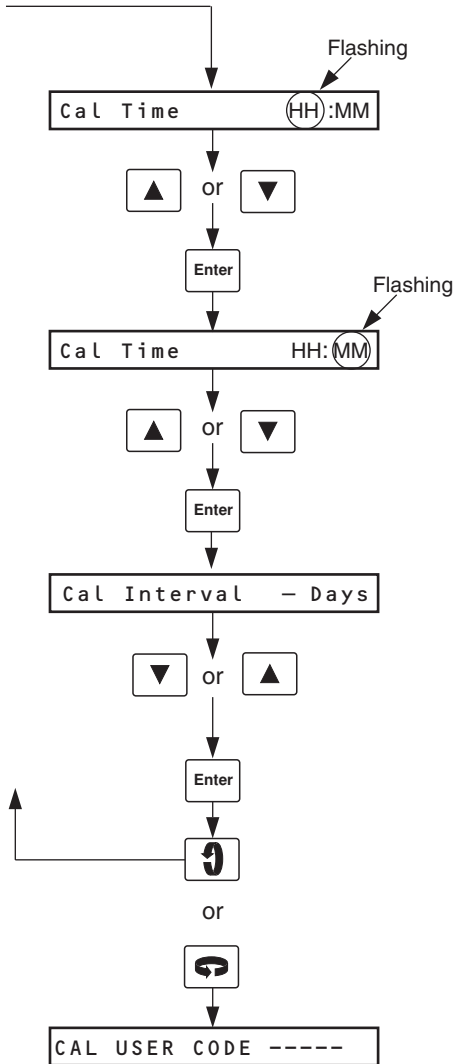

Calibration Time (hour – 24 hour clock)

Set the hour of the day when the first automatic calibration is to be carried out.

Store and advance to next parameter.

Calibration Time (minutes)

Set the minute of the hour when the first automatic calibration is to be carried out.

Store and advance to next parameter.

Calibration Interval

Set the calibration interval required between automatic calibrations, starting from the calibration date (6 hours, 12 hours or 1 to 7 days in 1 day increments).

Store.

Return to top of **Set Up Clock Page**.

or

Advance to **Calibration User Code Page**.

6.2.8 Calibration User Code Page

The calibration user code is required to gain access to the Set Up Temperature Control and Calibration Pages. The access code can be altered in the Calibration Page, if required – see Section 6.2.11.

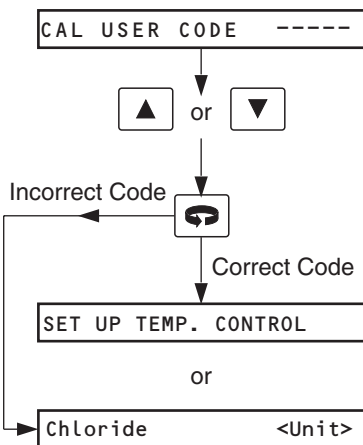

Calibration User Code

Set the correct user code.

Advance to next programming page.

Set Up Temperature Control Page.

or

Return to **Operating Page 1**.

6.2.9 Set Up Temperature Control Page

Note. All parameters within this page are factory preset and MUST NOT be altered.

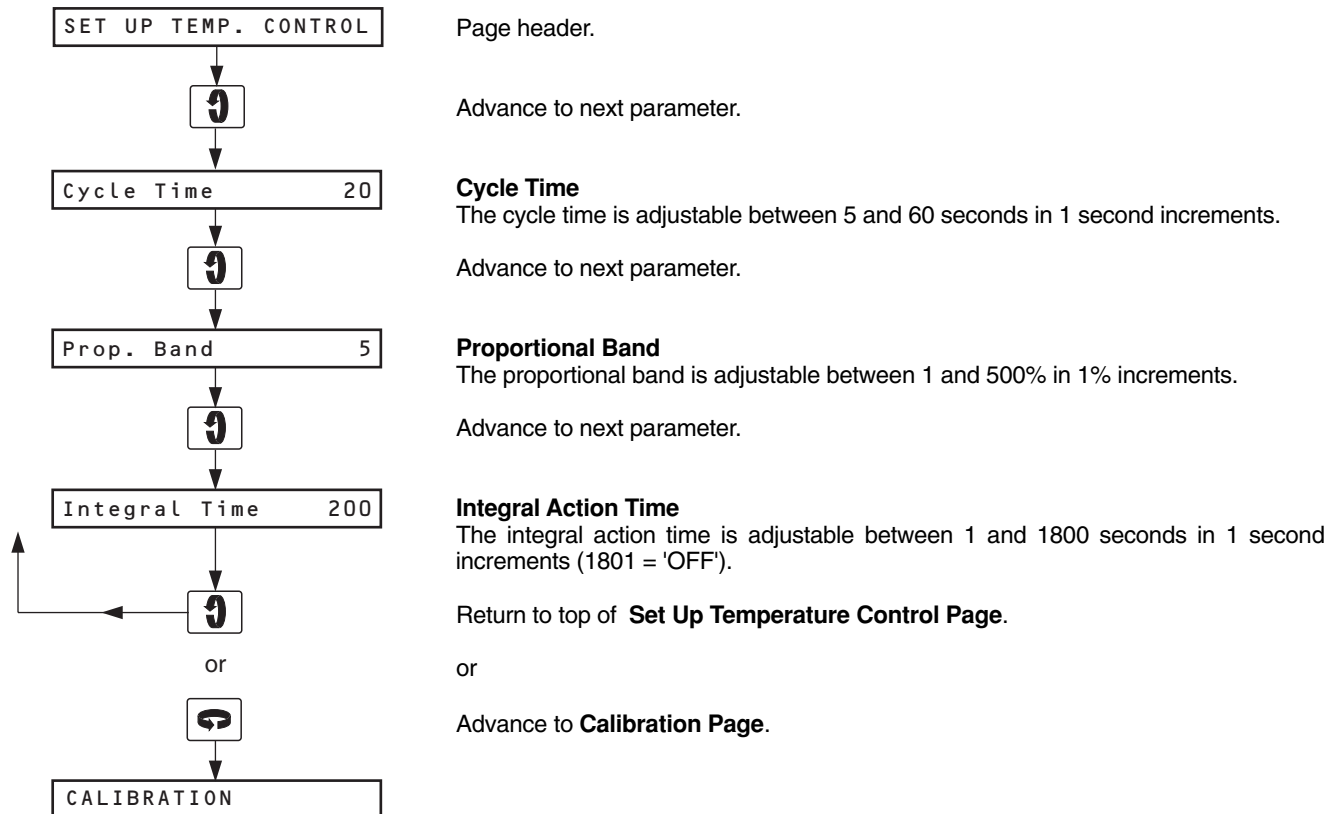

6.2.10 Electrical Calibration

Electrical calibration is carried out prior to despatch and should require no subsequent adjustment. However, if measurements become suspect or if the contents of the 'CALIBRATION' page are inadvertently altered, calibrate as detailed in the following sections.

Note. The calibration procedure involves modifying part of the original programme but, **provided that changed values are not stored using the 'Enter' switch**, the original programme, which was stored in the nonvolatile memory, can easily be reinstated at the end of calibration by switching off the instrument and switch on again.

If there is thought to be any risk that the original programme could be lost, it is advisable to make a note of the normal parameter settings. If the changed programme values are inadvertently 'Entered', the instrument can be reprogrammed on completion of the calibration procedure.

Equipment Required

- Millivolt source, range -400 to $+400$ mV.
- Electrode co-axial plug/lead assembly, supplied with monitor.
- Decade resistance box*, 0 to $1\text{ k}\Omega$ in $0.01\ \Omega$ increments.

- Digital milliammeter, 0 to 20 mA – refer to Fig. 2.4 to identify the output range.

* Resistance boxes have an inherent residual resistance which may range from a few milliohms to one ohm. This value must be taken into account when simulating input levels, as must the overall tolerances of the resistors within the box.

Preparation

- Switch off the supply and disconnect the temperature sensor leads from terminals 1, 2 and 3 in the microprocessor unit. Make the following connections:

1 & 3 (temperature sensor) }
2 (temperature sensor) }—decade box

- Insert the co-axial plug into the ISE socket above the flowcell and connect the millivolt source (inner +ve, outer -ve).
- Connect the milliammeter in place of the appropriate current output connections in the junction box – see Section 2.6.
- Switch on the supply and allow two minutes (30 minutes from cold) for the circuits to stabilise.
- Select the appropriate **Cal User Code** to gain access to the programming pages – see Section 6.2.8

...6 PROGRAMMING

6.2.11 Electrical Calibration Page

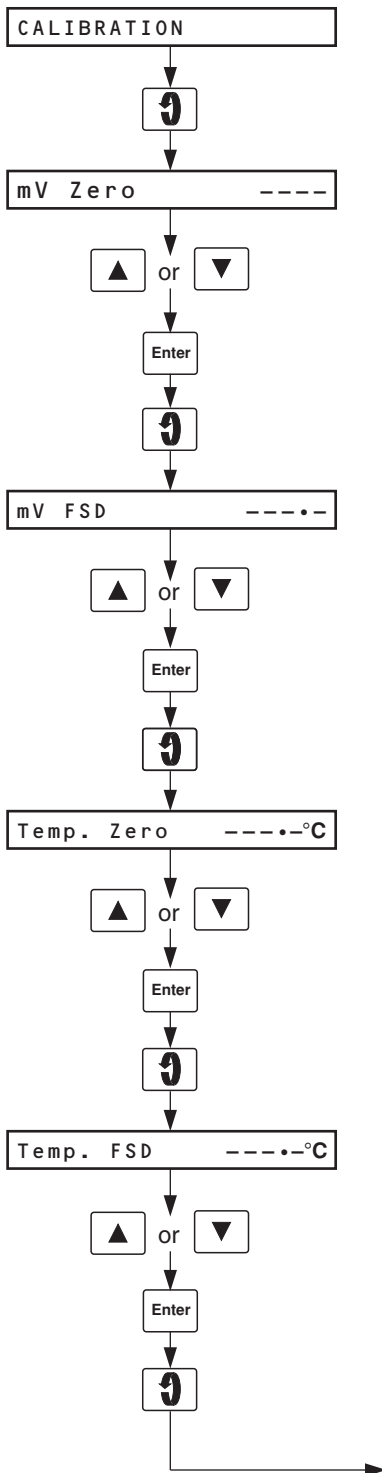

Page header.

Advance to next parameter.

Millivolt Input Zero

Set the millivolt source to -400 mV.

Set the display to ' -400 ' mV.

Store. New value is accepted only when input is stable.

Advance to next parameter.

Millivolt Input Full Scale

Set the millivolt source to $+400$ mV.

Set the display to ' $+400$ ' mV.

Store. New value is accepted only when input is stable.

Advance to next parameter.

Temperature Zero

Set the resistance box to 96.09Ω (resistive equivalent of -10 °C).

Set the display to ' -10 °C'.

Store. New value is accepted only when input is stable.

Advance to next parameter.

Temperature Full Scale

Set the resistance box to 142.29Ω (resistive equivalent of 110 °C).

Set the display to ' 110 °C'.

Store. New value is accepted only when input is stable.

Advance to next parameter.

Continued on next page.

...6.2.11 Electrical Calibration Page

Continued from previous page.

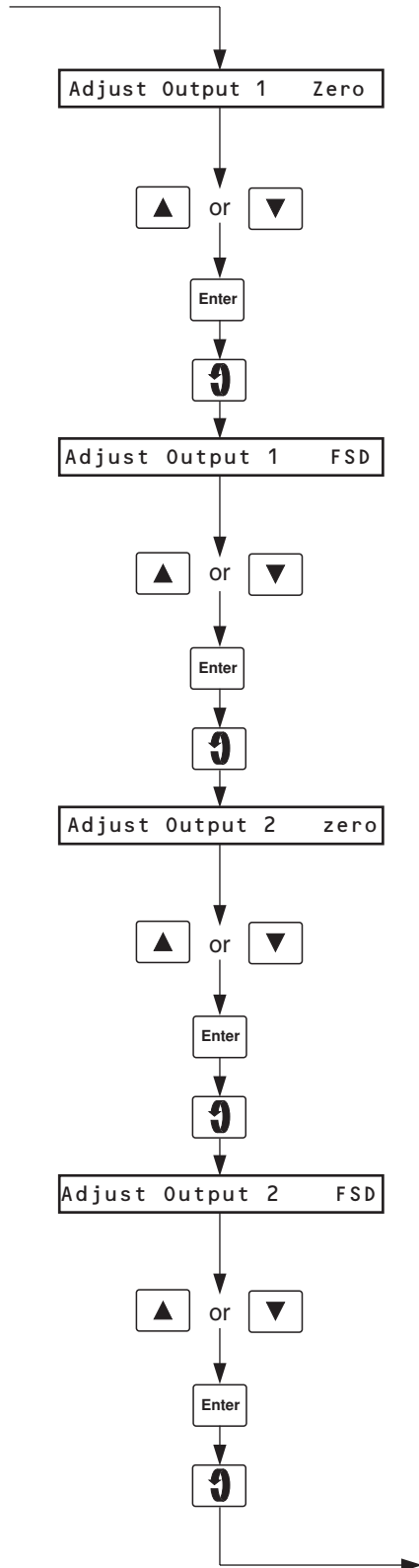
**Adjust Current Output 1 Zero**

The monitor transmits a zero signal, e.g. for a 4 to 20 mA output range, 4 mA is transmitted.

Set the milliammeter reading to the current output 1 zero level, i.e. 0 mA (zero-based ranges) or 4 mA (4 to 20 mA range).

Store.

Advance to next parameter.

Adjust Current Output 1 Full Scale

The monitor transmits a span signal, e.g. for a 4 to 20 mA output range, 20 mA is transmitted.

Set the milliammeter reading to the current output 1 full scale level, i.e. 1 mA, 10 mA or 20 mA as applicable.

Store.

Advance to next parameter.

Adjust Current Output 2 Zero

The monitor transmits a zero signal, e.g. for a 4 to 20 mA output range, 4 mA is transmitted.

Set the milliammeter reading to the current output 2 zero level, i.e. 0 mA (zero-based ranges) or 4 mA (4 to 20 mA range).

Store.

Advance to next parameter.

Adjust Current Output 2 Full Scale

The monitor transmits a span signal, e.g. for a 4 to 20 mA output range, 20 mA is transmitted.

Set the milliammeter reading to the current output 2 full scale level, i.e. 1 mA, 10 mA or 20 mA as applicable.

Store.

Advance to next parameter.

Continued on next page.

6 PROGRAMMING

...6.2.11 Electrical Calibration Page

Continued from previous page.

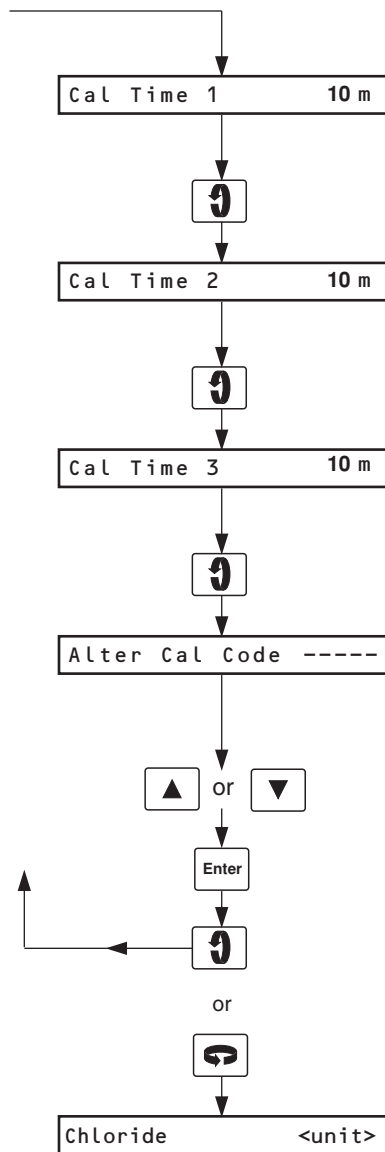

Calibration Time 1

The displayed value is preset at the factory and must not be altered. See Table 7.1.

Advance to next parameter.

Calibration Time 2

The displayed value is preset at the factory and must not be altered. See Table 7.1.

Advance to next parameter.

Calibration Time 3

The displayed value is preset at the factory and must not be altered. See Table 7.1.

Advance to next parameter.

Alter Calibration Code

The calibration user code inhibits access to the **Set Up Temperature Control Page** and the **Calibration Page** – see Section 6.2.8.

Set a suitable user code, between 0 and 19999.

Store.

Return to top of **Electrical Calibration Page**.

or

Return to **Operating Page 1**.

7 CALIBRATION

7.1 Calibration Sequence

Calibration of the monitor is carried out by replacing the sample solution sequentially with two standard solutions of known concentration. This calibration sequence (see Table 7.1) can be initiated automatically at preset times, or manually on demand.

The sensor outputs obtained during calibration are used to calculate the calibration graph for the monitor and the accuracy of the standard solutions will, therefore, have a direct effect upon the overall accuracy of the monitor. Given accurate standards, it is clear that the best accuracy would be expected at the two calibration points. Ideally, the concentrations of the two standards should bracket the expected sample concentration closely, but the latter often varies quite widely. In practice it is convenient, and often the best compromise, to use standards whose concentrations are one decade apart, i.e. differ by a factor of 10, and bracket the expected range of sample concentrations. For example, if the range of sample concentrations is expected to be 5 to 10 ppm, then standards of 2 and 20 ppm could be used.

Note. The concentrations of the two standard solutions must differ from each other by a factor of at least four.

On initiation of the calibration sequence, either manual or automatic, the 'Cal' l.e.d. is illuminated and the Calibration Mode relay is energized. Two solenoid valves, SV1 and SV2 operate

sequentially to shut off the sample and admit standard solutions of known concentration, one low and one high (STD1 and STD2), to the sample path.

Once a valve is energized, sufficient time (preset to suit the sensor response time) is allowed for the previous solution to be displaced, and for the sensor to respond to the new solution, before the sensor output is evaluated for stability by the microprocessor. When a stable output is achieved the next stage in the sequence is initiated.

After calibration the sensor outputs corresponding to the two standard solutions are used to calculate a new calibration graph for the monitor, thus compensating for any drift in sensor or liquid handling performance characteristics since the last calibration, and the new slope value can be displayed in Operating Page 1 (100% slope is the theoretical value).

If the values are within limits, 'CALIBRATION PASSED' is displayed.

'CAL FAILED (SLOPE)' is displayed if the slope value is outside acceptable limits and 'CAL FAILED (SLOW)' is displayed if the sensor output failed to stabilize within 15 minutes after the end of Cal Time 1 or Cal Time 2.

Activity	Introduce STD1	Sensor Stabilises	Introduce STD2	Sensor Stabilises	Introduce Sample	Normal Operation
Valve Open	SV1	SV1	SV2	SV2	None	None
Timing	Preset (Cal Time 1)	Variable *	Preset (Cal Time 2)	Variable *	Preset (Cal Time 3)	None

*15 min. max.

Table 7.1 Calibration Sequence Summary

8 MAINTENANCE

8.1 Chemical Solutions

The reagent and standard solutions described below are required to maintain the monitor in operation. Where possible, they should be freshly made and stored in plastic (for example, polythene) bottles. Typical reagent solution consumption for a continuously operating monitor is approximately ten litres per month. The monitor uses 100 to 150 ml of each standard solution each calibration cycle. Consumption of the standard solution also depends on the frequency with which this cycle is carried out.

8.1.1 Reagent Solution

0.5 M ammonium acetate + 0.5 M acetic acid

Warning.

- Concentrated ammonia should only be handled under a fume hood. It causes burns and is irritating to the eyes, respiratory system and skin. Wear rubber gloves and eye protection. In warm weather, pressure increases in the bulk container of ammonia and the cap must be released with care.
- Concentrated (glacial) acetic acid must be handled with care under a fume hood. It is flammable and causes burns. Wear rubber gloves and eye protection.

To prepare 10 litres of the reagent, proceed as follows:

- Carefully** add 570 (± 5) ml analytical reagent grade glacial acetic acid (CH_3COOH , 1.05 s.g.) to approximately 5 litres of high purity water.
- To this solution **carefully** add 275 (± 5) ml analytical reagent grade ammonia solution (NH_4OH , 0.88 s.g.).

Note.

For 0.91 s.g. ammonia solution, use 350 (± 5) ml.

- Mix and dilute to 10 litres with more high purity water. The pH of this solution should be 4.5 ± 0.2 .

Note.

In certain applications, air bubbles from sample degassing may collect on the electrode membrane. To remove these bubbles add 50 (± 5) ml of 10% 'Brij 35' solution to 10 litres of reagent. 'Brij 35' (polyoxyethylene lauryl ether, a non-ionic surfactant) is available as a solid or as a 30% solution from Merck Ltd.

8.1.2 Reference Electrode Filling Solution

The reference electrode contains a salt bridge solution of 1.0 M sodium sulphate. Prepare as follows:

- Dissolve 14.2 (± 0.1) g analytical grade anhydrous sodium sulphate in approximately 80 ml of high purity water.
- Dilute the solution to 100 ml with more high purity water.
- Store the solution in a tightly stoppered plastic bottle.

8.1.3 Standard Solutions

Two standard solutions of known chloride concentration appropriate to the measuring range are required to calibrate the monitor. To prepare a stock solution of 10,000 mg l^{-1} chloride ions, proceed as follows:

- Dry approximately 20 grams of analytical reagent grade sodium chloride at 140°C for four hours.
- Weigh out 16.48 (± 0.01) g of the dried salt; dissolve it in approximately 400 ml of high purity water and make up to 1 litre in a volumetric flask with more high purity water. This is a 10,000 mg l^{-1} chloride solution.
- Prepare the standard solution required by accurate dilution of the 10,000 mg l^{-1} stock solution.

8.2 Scheduled Servicing

The following servicing schedule has been produced as a general guide only. It may be necessary to amend the schedule to suit the particular installation and sample conditions.

8.2.1 Regular Visual Checks

It is recommended that the monitor and the sampling system is visually inspected on a regular basis to check the correct functioning of the system and to assure the integrity of the readings.

- Check for leaks, particularly around the sample and drain pipework connections.
- Confirm sample flow by checking delivery to the constant head unit and effluent from the drain.
- Check liquid flow through sensor flowcell.
- Check for excessive build-up of air in the flowcell.
- Check liquid levels in the reagent and standard solution containers.
- Check for malfunction indications on the instrument display.

Note. The mains and pump/heater switches are situated on the right hand side of the User Junction Box.

8.2.2 Four Weekly

- Inspect all tubing and flowcell for leaks and deterioration.
- Examine all tubing and flowcell for signs of accumulation of solid deposits. These tend to accumulate in the reference electrode compartment of flowcells and may be cleaned to drain by squirting high purity water from a 'squeezy' bottle into the de-bubbler vent on top of the flowcell, and the use of small bottle brush.
- Clean monitor pipework if necessary.
- Check the filling solution in the reference electrode and top-up if necessary.

- e) Discard old reagent and standard solutions. Clean containers thoroughly before refilling with fresh solutions – see Section 8.1.

Note. It is vital that the containers are **not** topped up.

- f) Examine the sample input pipe for leaks and deterioration.
- g) Check the condition of the sample filter (if fitted) and fit a new one if necessary. Ensure that new filters are fitted correctly by taking note of the flow directions indicated on the filter bodies.
- h) Ensure the drain is in good order and free from obstruction.

8.2.3 Twelve Monthly

- a) Service pump, tubing and capstans – see Section 8.2.6.
- b) Replace all internal plumbing tubing – see Section 8.2.7.
- c) Carry out the normal 4 weekly schedule not already covered above.

8.2.4 Consumables Spares Kit

The monitor is supplied with a consumable spares kit (see Section 10). This consumable spares kit includes all the components which are recommended for replacement annually (refer to the details in the spares kit). This annual refurbishment ensures a high level of reliability from the monitor over a period of many years. The kit should be reordered when used so that all the items are available throughout the following year's operation. The consumable spares kit is in addition to the electrode spares kits for the chloride electrode.

The kit contains the following:

- one set of pump tubing
- one set of pump capstans
- a complete set of plumbing tubing
- sundry items – 'O' rings, tube connectors, pump tube bungs and fuses
- plastic syringe and bottle brush – for cleaning pipework, valves, flowcell and constant-head unit.

8.2.5 Fitting the Electrodes

The chloride electrode is supplied with a protective end cap to prevent the tip from being scratched or chipped. To prepare for use, remove the end cap and carefully rinse the tip in distilled water.

- a) Fit the chloride electrode into the plastic holder supplied, slide the retaining 'O' ring over the end of the electrode body and insert it into the sloping aperture of the flowcell. Screw down to compress the 'O' ring. Push the electrode down as far into the flow cell as practical without fouling the stirrer drum.
- b) Connect the chloride electrode lead to the co-axial socket above the flowcell on the right hand side.
- c) The reference electrode should have the rubber stopper removed from the refill aperture. Remove teat and top-up electrode with filling solution if required.
- d) Fit the 'O' ring supplied over the reference electrode body and insert the electrode into the left hand chamber of the flowcell so that the ceramic plug is between 5 and 10 mm from the bottom.
- e) Connect the reference electrode lead to the co-axial socket above the flowcell on the left hand side.

...8 MAINTENANCE

8.2.6 Peristaltic Pump – Fig. 8.1

It is recommended that the pump tubing and pump capstans, supplied in the Consumable Spares Kit, are replaced after one year of operation. Carry out the following procedure ① to ⑧:

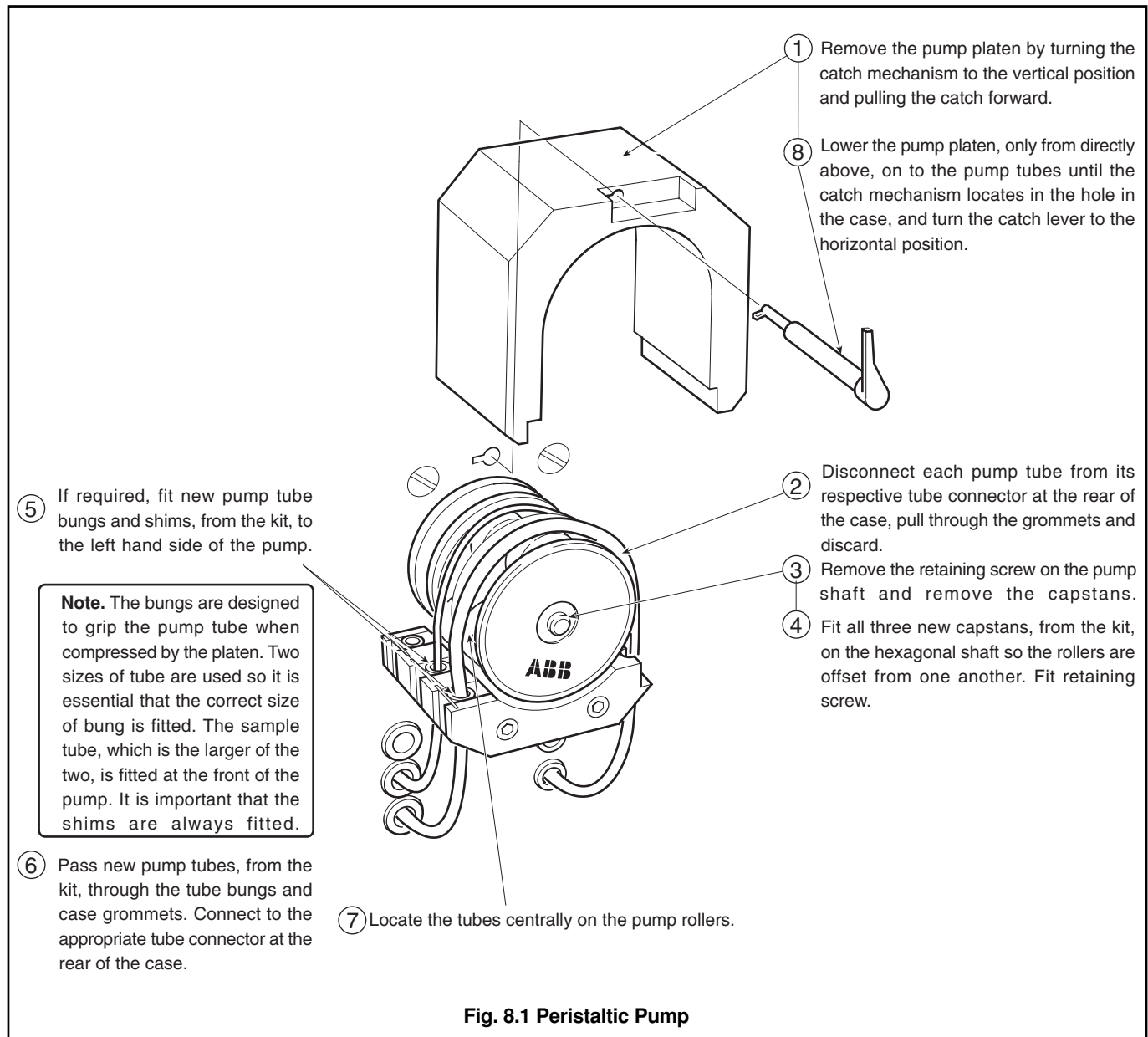

8.2.7 Replacement of Plumbing Tubing

All the following items are included in the Consumable Spares Kit.

- Remove electrodes for short term storage.
- Remove each section of the sample and reagent plumbing tubing in turn and replace with new tubing of the same length.
- Remove drain tubing and replace with new tubing of the same length.
- Using a syringe, clean constant head unit, solenoids and sample heating coil in flowcell with sodium hypochlorite solution.
- It is recommended that the sample and drain tubing to and from the monitor is inspected and replaced if the tubing is in poor condition or shows evidence of any build-up of solids.

8.3 Shutdown Procedure

8.3.1 Short Term

The monitor can be left with the power switched off for up to 24 hours without any detrimental effects. When returned to normal monitoring mode, the monitor should be run on sample for 30 minutes, followed by a calibration – see Section 7.

The chloride electrode should be stored dry.

The reference electrode may be stored in high purity water or filling solution. Ensure that the electrode cannot dry out; failure to observe this results in a blocked ceramic junction, causing considerable delay when restarting the monitor.

If the chloride electrode is likely to be out of service for more than one day, remove the electrode from the monitor and store it dry with the protective end cap replaced to prevent the tip being scratched or damaged. The reference electrode is stored with its ceramic junction covered by a protective teat containing filling solution. Refit the stopper in the filling solution hole.

8.3.2 Long Term

When the monitor is required to be shut down for more than 24 hours, proceed as follows:

- a) Switch of the monitor.
- b) Close the sample valve up-stream of the monitor.
- c) Remove the electrodes and store – see Section 8.3.1.
- d) Clean constant head unit, and sample pipework (both inside and outside the monitor).
- e) Remove pressure plate from peristaltic pump.

8.4 Unscheduled Servicing

The monitor indicates abnormal operation by means of signals on the 20 character dot matrix display and the l.e.ds. The indications are listed in Table 8.1.

8.4.1 Malfunction of the Monitor

It should always be remembered that any unpredictable problems may be due to the standard or reagent solutions, or their flow through the flowcell. If any doubts exist regarding the integrity of the solutions, they should be replaced with freshly prepared solutions in the early stages of the fault finding investigations.

Note. The accuracy of the monitor is governed by the condition of these solutions which may be incorrectly made or contaminated.

In general, any problems are likely to be due to the electrodes, which may require refurbishment (see Section 8.4.3), but may be due to other parts of the liquid handling section of the monitor.

Mechanical components which are involved with the liquid handling, for example, pumps, valves, tubing and tubing connections etc., should be systematically checked for correct operation, and for leaks or blockages which change the chemical conditions around the electrode. The majority of all problems are found to be associated with the chemistry and the liquid handling section.

Display	Possible Cause
'CALIBRATING Std 1 (or 2) Cal L.E.D. flashing	Normal when calibration is taking place. 'Std 1' or 'Std 2' refers to the standard solution being admitted at the time.
'CALIBRATION PASSED'	A recent two point calibration has been successfully carried out.
'CAL. FAILED (SLOPE) Fail L.E.D. flashing	The slope value calculated from the electrode potentials during calibration was outside the acceptable limits.
'CAL. FAILED (SLOW) Fail L.E.D. flashing	The monitor was unable to achieve a stable output from the electrodes during calibration.
'TEMP. CONTROL ERROR'	The sensor flowcell temperature is significantly different from the Control Temperature.
'OUT OF SAMPLE'	Indicates loss of sample.
Hold L.E.D. 'ON'	This indicates the Hold button has been pressed to freeze the concentration alarm states and to activate the Out of Service alarm relay. Pressing the button again returns the monitor to normal operation after a period of 3 hours.

Table 8.1 Unscheduled Servicing Messages

...8 MAINTENANCE

8.4.2 Monitor Diagnostic Information Out of Service Alarm

This alarm relay output is a normally energised relay which de-energises in the following circumstances:

- Loss of mains supply.
- Calibration Failed – the calculated electrode slope value is outside the acceptable limits or the response of the electrode is too slow. The 'CAL FAIL' i.e.d. on the front panel is illuminated with the appropriate text on the 20-character display.
- Flowcell temperature out of limits – the measured temperature is not within 5°C of the Control Temperature. 'TEMP. CONTROL ERROR' is indicated on the 20-character display.
- 'OUT OF SAMPLE' alarm – a float switch in the constant head unit detects the loss of sample. 'OUT OF SAMPLE' is indicated on the 20-character display.
- 'OUT OF SERVICE' alarm – displayed when the pump is switched off.

Note. The heater is switched off by the software when an 'OUT OF SAMPLE' condition is detected.

Calibration Fail Alarm

A calibration failed condition occurs after a two point calibration if the calculated slope value is less than 80% or if the electrode output is unstable. The failure could be caused by a number of factors which should be investigated.

In the 'CAL. FAILED (SLOPE)' case some indication of the problem may be obtained from the slope value.

Slope value just below 80%

- Check the reagent solution flows.
- Check condition of the reagent solutions.
- Check condition of the standard solutions.
- See **Malfunction of the Electrode** Section 8.4.3.

Slope value grossly abnormal

- Check operation of the solenoid valves and flow of the standard solutions.
- Check condition of the standard solutions.
- Check the reagent solution flows.
- Check condition of the reagent solutions.
- Check liquid level in reference electrode – see **Malfunction of the Electrode** Section 8.4.3.
- Check electrode connections in the co-axial plugs and sockets, and inside the microprocessor unit.

- See **Malfunction of the Electrode** Section 8.4.3.
- Check operation of the Microprocessor Unit by following the procedure in Section 6.2.10, **Electrical Calibration**.

Calibration Failed (Slow)

In the 'CAL. FAILED (SLOW)' case the failure is usually due to slow electrode response, but may be due to an unstable (noisy or drifting) electrode output:

- Check for air bubbles trapped on chloride electrode surface. Remove if necessary and ensure that the temperature sensor is not positioned too low down in the flowcell.
- Check electrode connections in the co-axial plugs and sockets, and inside the microprocessor unit.
- See **Malfunction of the Electrode** Section 8.4.3.

8.4.3 Malfunction of the Electrode

Caution. Suspected faulty electrodes cannot be disassembled to investigate any problems.

- Check for surface deposits on the chloride electrode sensing surface. See Section 8.5.
- Check performance of chloride electrode by substitution.
- Check level of filling solution in reference electrode; top up if necessary.
- Check that the rubber stopper has been moved away from the filling solution hole in the reference electrode.
- Reference electrode liquid junction partially or completely blocked, replace electrode if required.

8.5 Reconditioning the Chloride Electrode

In time the response time of the chloride electrode may become extended and the general performance deteriorates to an unacceptable level. The electrode loses its normal grey-brown appearance but can be re-chloridised as follows:

- Requirements

Note. Do not use acid preserved with mercuric ions

Caution. Strong ammonia solutions and strong nitric acid are both very poisonous and corrosive. Care should be taken not to inhale the fumes of either or to get any on skin or clothing. Any slight spillage on skin, clothing or working surfaces should be washed away with plenty of water.

Chemicals

- Plating solution
Hydrochloric acid, 0.1M (500ml)
- Cleaning solutions
Ammonia solution 50% (250ml)

To prepare, dilute 125 ml A.R. concentrated ammonia solution s.g. 0.88, with 125 ml distilled water and stir.

Nitric acid, 50% (250ml)

To prepare, cautiously pour 125ml A.R. concentrated nitric acid, s.g. 1.42, into 125ml distilled water, stirring continuously. Allow to cool before use.

Hardware

Constant current supply, 2mA d.c. output.

Silver wire (as working electrode)

1 Beaker.

2) Cleaning

Clean the silver billet by immersing the end of the electrode in the ammonia solution for about 1 minute. The ammonia solution should cover all the billet and a short length of the white plastic body. Rinse the electrode with distilled water. Immerse the end of the electrode to the same depth as before in the 50% nitric acid (CAUTION) until the colour of the silver is an even white (this usually takes about 1 minute). Repeat the process if uneven in colour. Rinse the electrode with distilled water and immediately transfer to the plating solution.

3) Chloridisation

Plug the electrode to be chloridised into the negative terminal of the current supply. the electrode should be immersed in the plating solution so that it covers all the exposed silver and a short length of the white plastic body. Put a silver working electrode in the beaker as far from the other electrode as possible and join a lead from this to the positive terminal of the constant current supply. Pass a current of 2mA for 30 seconds. Switch off the current and lightly tap the electrode to dislodge all the bubbles on the billet. Reverse the polarity of the current supply and pass the same current as before for 20 minutes. A more even coating may be obtained by employing moderate stirring.

4) Rinse the electrode in de-ionised water.

5) Assemble in flowcell and check the performance.

If the performance is still not acceptable, repeat the above procedure.

8.6 Microprocessor Unit Error Messages

The instrument incorporates an automatic self-diagnostic checking facility for detection of input and output errors. If such a fault occurs, one of the error messages detailed below is shown on the dot matrix display.

'CHAN 1 INPUT ERROR'

This error message is usually caused by an open circuit electrode input. This may be due to any of the following:

- a) Electrode open circuit internally, e.g. broken connection, blocked liquid junction or low level of filling solution in reference electrode etc.
- b) Air bubble build-up between electrodes.
- c) Broken electrical connections between the electrode and the Microprocessor Unit input.
- d) Co-axial plugs not correctly inserted.

'TEMP INPUT ERROR'

'PRT OUT OF LIMITS'

'TEMP REF. ERROR'

'THIRD LEAD ERROR'

The above four error messages refer to electrical problems with the temperature sensor input, – usually an open or short-circuit connection.

9 SPECIFICATION

Range		Calibration	
Chloride	Any two consecutive decades of concentration between 2 and 5000mgL ⁻¹ chloride		Fully automatic two-point, plus manual initiation on demand
Repeatability	±2% of reading	Routine maintenance	
		Four-weekly:	replenish reagents, clean flow system
Reproducibility	±3% of reading	Twelve-monthly:	replace plumbing, pump tubing and pump capstans
Response time	Less than 5 minutes for 90% step change	Power supply	110 to 120V or 220 to 240V 50/60Hz 100VA
Millivolt range	-400mV to +400mV	Power supply tolerance	+6% to -10%
Millivolt resolution	±0.1mV	Isolation voltage	Input, output and power supply 1.5kV
Control temperature range	30 to 45°C (86 to 113°F)	Weight	
Temperature resolution	±0.1°C (±0.2°F)	Approximately	35kg (77lb)
		Dimensions	
Displays		Height	893mm (35.2 in.)
Concentration	5-digit blue fluorescent	Width	541mm (21.3 in.)
Information	20-character dot matrix blue fluorescent	Depth	207mm (8.2 in.)
Status indication		Degree of protection	
Two flashing LED's in alarm state		Electronics section	IP65
Single LED lit when 'HOLD' switch operated		Liquid handling	Case IP31
Single LED lit when calibration is in progress			Critical internal components IP65
Single LED lit when the monitor is 'Out of Service'			
Current outputs			
As standard one isolated current output 0 to 1, 0 to 10, 0 to 20 or 4 to 20mA selectable via plug-in links			
Optional 2 nd current output			
Maximum voltage load 15V			
Current output span			
Any 1 to 2 decades of display range, logarithmic or linear			
Computer interface			
Modbus via RS433/RS423 serial interface			
Alarms			
Two high or low concentration alarms			
Remote calibration mode indication			
Remote monitor 'Out of Service' indication,			
includes:	Loss of Mains Supply		
	Loss of Sample		
	Calibration Failed		
	Electronic Failure		
All voltage-free 250V 5A non-inductive changeover relay contacts			
Concentration alarm adjustment			
Programmable over assigned range			
Concentration alarm differential			
Programmable 0 to 5%			
Concentration alarm delay			
Programmable 0 to 60 minutes			

SS/8230 Issue 9

10 SPARES

Consumable Spares

Part No.	Description	Qty
8230 020	Consumable spares kit comprising pump tubes, pump capstans, plumbing tubing, tube connectors and 'O' rings etc.	1

Refurbishment Spares

Part No.	Description	Qty.
8235 150	Chloride electrode	1
1433 830	Reference electrode – silver/silver chloride, double junction	1
8231 242	Electrode retaining sleeve	1
8231 235	Sample heater coil	1
8236 260	Reagent bottle assembly	1
8022 990	Tube connector – 9 mm i.d. flowcell drain	1
8230 220	Standard solution bottle assembly – 'Low'	1
8230 221	Standard solution bottle assembly – 'High'	1
8063 710	Container tube sinker	3
0214 514	Hose connector – sample inlet 6mm i.d.	1
0214 526	Hose connector – monitor drain 9mm i.d.	2
8230 240	Temperature sensor assembly	1
0234 019	Solenoid valve	2
8231 240	Flowcell stirrer magnet	1

Strategic Spares

Part No.	Description	Qty
8232 280	Inlet manifold and drain	1
8061 864	Float switch – 'Out of Sample'	1
8230 208	Pump motor including 10 μ F capacitor (4 rpm @ 50 Hz)	1
8035 870	Pump motor coupling assembly	1
0216 244	Cartridge heater	1
0234 712	Heater thermal cut-out	1
8231 239	Flowcell assembly	1
0232 325	Mains transformer – user junction box	1
0234 726	Toggle switch – mains and pump	2
0234 714	Toggle switch boot	2
8230 130	PCB assembly – user junction box	1
0239 117	Electrode coaxial plug	1
0239 118	Electrode coaxial socket	1
0232 033	Stirrer motor	1
4500 0845	Processor board (without PSD)	1
4500 0817	Power supply board assembly	1
4500 0140	Display board pack assembly	1
4500 0255	Current O/P board	1
8230 055	mV input board	1
4500 0855	Serial Modbus PCB assembly	1

...10 SPARES

...Strategic Spares

Part No.	Description	Qty.
4500 0265	Temperature Input Board	1
4500 0285	Power supply board	1
4500 0275	5-Digit, 7-segment display board	1
4500 0443	5-Digit display flexi-circuit	1
4500 0603	Display flexi-circuit	1
4500 0395	Membrane switch	1
-	Programmable system device (PSD) – English	1

Fuses (Junction Box)

Part No.	Description	Qty.
0231 558	F1 – 1A 20 x 5mm Anti-surge 250V AC	1
B10208	F2 – 5A 20 x 5mm Quick Blow 250V AC	1
0231 596	F3 – 0.5A 20 x 5mm Anti-surge 250V AC	1

Fuse (transmitter Power Supply Board 4500/0817)

Description	Qty.
F1 – Not a site-serviceable fuse, contact the company	1

APPENDIX A – REPLACING SOFTWARE EPROM

Warning. Switch off the monitor and electrically isolate it before carrying out the following steps.

A.1 Access the Transmitter Unit – Fig. A.1

Caution. Employ normal antistatic precautions while handling chips and PCBs.

Caution. To avoid damaging EPROM, base or PCB, it is essential that you use an approved IC extractor in this procedure.

For example, a PLCC Extractor, RS Stock Number: 404-727

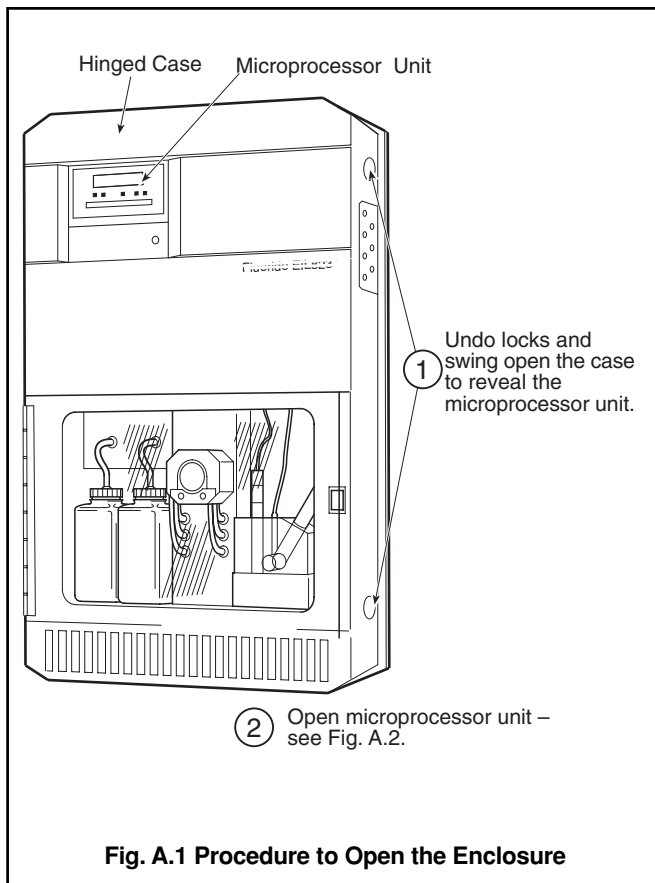

A.2 Access the PCB – Fig. A.2

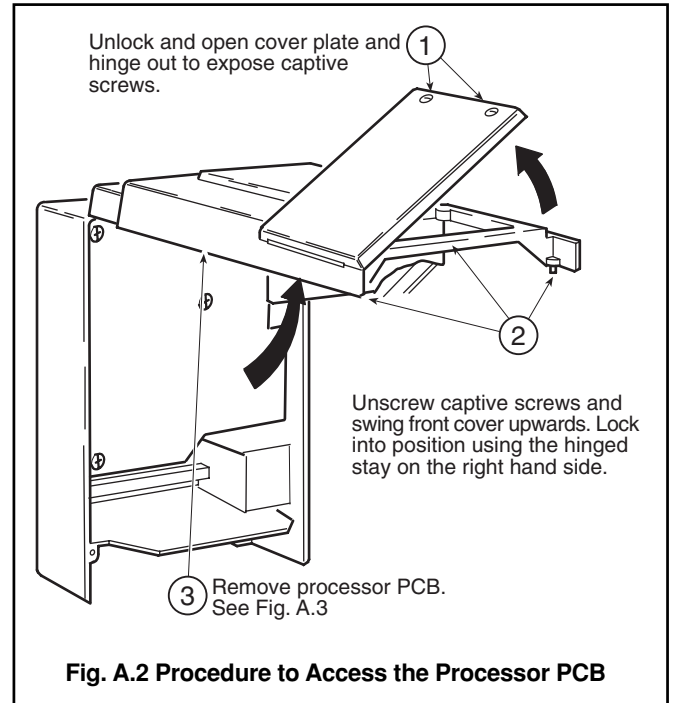

A.3 Removing the PCB – Fig. A.3

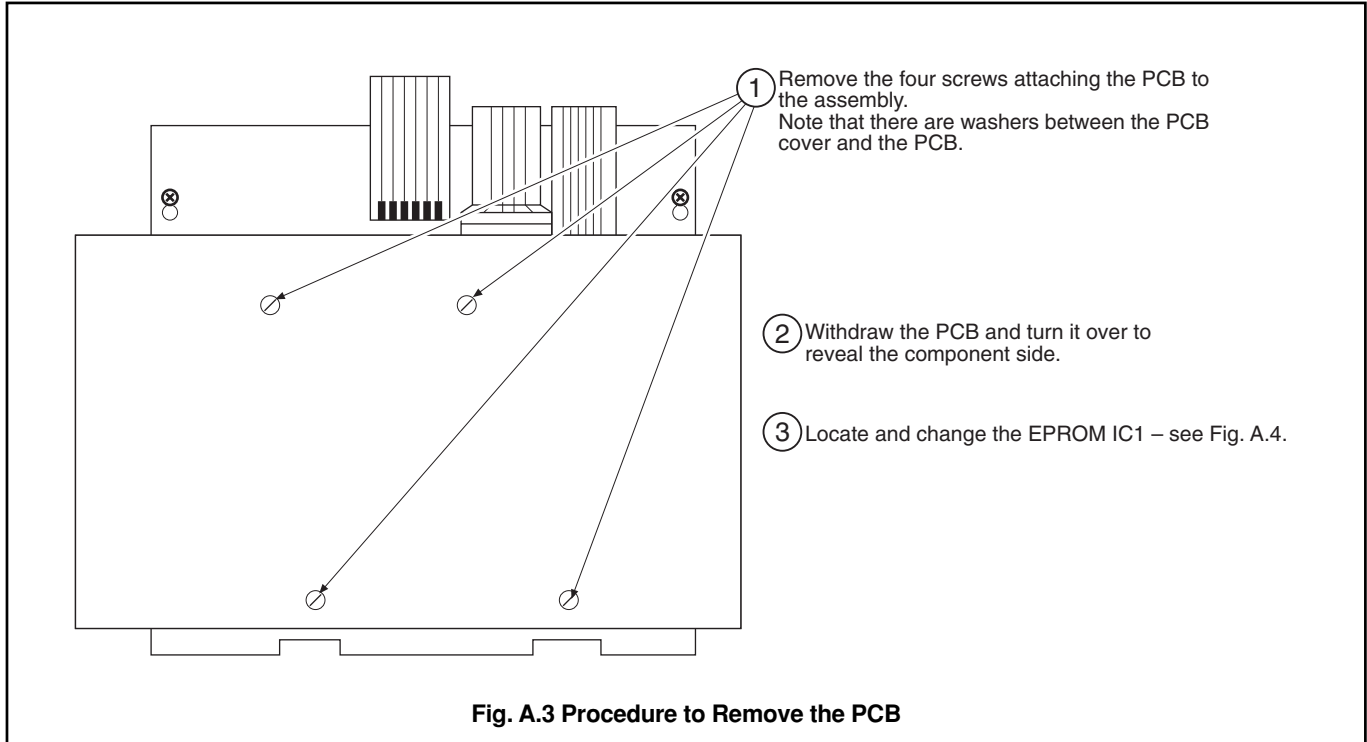

A.4 Replacing the EPROM – Fig. A.4

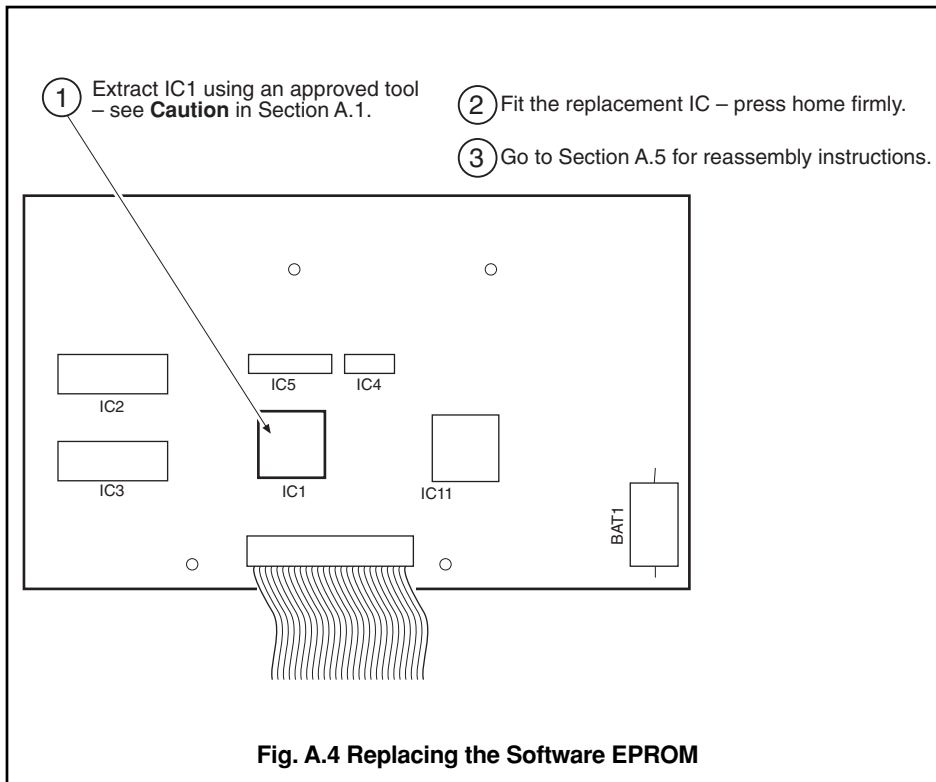

A.5 Completing the Procedure

1) Fit the PCB using the reverse procedure in Fig. A.3.

Important Note. Ensure that the washers are fitted between the PCB cover and the PCB.

- 2) Close the microprocessor section using the reverse procedure in Fig. A.2.
- 3) Close and lock the hinged cover – Fig. A.1.
- 4) The monitor may now be put into service.
- 5) Check program parameters – see Section 6.
- 6) Carry out a routine 2-point calibration.

PRODUCTS & CUSTOMER SUPPORT

Products

Automation Systems

- *for the following industries:*
 - Chemical & Pharmaceutical
 - Food & Beverage
 - Manufacturing
 - Metals and Minerals
 - Oil, Gas & Petrochemical
 - Pulp and Paper

Drives and Motors

- *AC and DC Drives, AC and DC Machines, AC motors to 1kV*
- *Drive systems*
- *Force Measurement*
- *Servo Drives*

Controllers & Recorders

- *Single and Multi-loop Controllers*
- *Circular Chart and Strip Chart Recorders*
- *Paperless Recorders*
- *Process Indicators*

Flexible Automation

- *Industrial Robots and Robot Systems*

Flow Measurement

- *Electromagnetic Flowmeters*
- *Mass Flow Meters*
- *Turbine Flowmeters*
- *Flow Elements*

Marine Systems & Turbochargers

- *Electrical Systems*
- *Marine Equipment*
- *Offshore Retrofit and Refurbishment*

Process Analytics

- *Process Gas Analysis*
- *Systems Integration*

Transmitters

- *Pressure*
- *Temperature*
- *Level*
- *Interface Modules*

Valves, Actuators and Positioners

- *Control Valves*
- *Actuators*
- *Positioners*

Water, Gas & Industrial Analytics Instrumentation

- *pH, conductivity, and dissolved oxygen transmitters and sensors*
- *ammonia, nitrate, phosphate, silica, sodium, chloride, fluoride, dissolved oxygen and hydrazine analyzers.*
- *Zirconia oxygen analyzers, katharometers, hydrogen purity and purge-gas monitors, thermal conductivity.*

Customer Support

We provide a comprehensive after sales service via a Worldwide Service Organization. Contact one of the following offices for details on your nearest Service and Repair Centre.

United Kingdom

ABB Limited
Tel: +44 (0)1453 826661
Fax: +44 (0)1453 829671

United States of America

ABB Inc.
Tel: +1 775 850 4800
Fax: +1 775 850 4808

Client Warranty

Prior to installation, the equipment referred to in this manual must be stored in a clean, dry environment, in accordance with the Company's published specification.

Periodic checks must be made on the equipment's condition. In the event of a failure under warranty, the following documentation must be provided as substantiation:

1. A listing evidencing process operation and alarm logs at time of failure.
2. Copies of all storage, installation, operating and maintenance records relating to the alleged faulty unit.

ABB has Sales & Customer Support
expertise in over 100 countries worldwide

www.abb.com

The Company's policy is one of continuous product
improvement and the right is reserved to modify the
information contained herein without notice.

Printed in UK (01.07)

© ABB 2007



ABB Limited
Oldends Lane, Stonehouse
Gloucestershire
GL10 3TA
UK
Tel: +44 (0)1453 826661
Fax: +44 (0)1453 829671

ABB Inc.
Analytical Instruments
9716 S. Virginia St., Ste. E
Reno, Nevada 89521
USA
Tel: +1 775 850 4800
Fax: +1 775 850 4808