

Effective: December 1978
Supersedes I.L. 41-162.2C Dated October 1974

Type POQ Negative Sequence Relay

(|) Denotes Change Since Previous Issue



Before putting relays into service, remove all blocking which may have been inserted for the purpose of securing the parts during shipment, make sure that all moving parts operate freely, inspect the contacts to see that they are clean and close properly, and operate the relay to check the settings and electrical connections.

1.0 APPLICATION

The type POQ relay is a sensitive instantaneous negative sequence current relay that is used to detect unbalanced conditions in a three phase power system. The relay will respond to faults, open phase, unbalanced impedance conditions or any similar phenomenon that produces negative sequence current higher than its setting. It is normally used with an external timer to provide coordination with other devices.

2.0 CONSTRUCTION & OPERATION

The POQ relay consists of a negative sequence current filter, a saturating transformer, a full wave rectifier, a sensitive permanent magnet type polar unit, an auxiliary switch, and an indicating contactor switch. These components are connected as shown in Figure 3.

2.1 NEGATIVE SEQUENCE CURRENT FILTER

The negative sequence current filter consists of a

three-legged iron core reactor and a resistor. The three windings are wound on the center leg of the reactor.

When unbalanced three phase currents are applied to the filter, an output voltage is obtained that is proportional to the input negative sequence current. This output voltage is applied to the tapped primary of a saturating transformer whose secondary is connected to the polar unit through a full wave rectifier.

2.2 POLAR UNIT

This unit consists of a rectangular shaped magnetic frame, an electromagnet, a permanent magnet, and an armature with contacts.

The poles of the crescent shaped permanent magnet bridge the magnetic frame. The magnetic frame consists of three pieces joined in the rear with two brass rods and silver solder. These nonmagnetic joints represent air gaps which are bridged by two adjustable magnetic shunts. The operating winding is concentrically wound around a magnetic core. The armature is fastened to this core at one end and floats in the front air gap at the other end. The moving contact is connected to the free end of a leaf spring.

2.3 INDICATING CONTACTOR SWITCH UNIT (ICS)

The dc indicating contactor switch is a small clapper type device. A magnetic armature to which leaf-spring mounted contacts are attached, is attracted to the magnetic core upon energization of the switch. When the switch closes, the moving contacts bridge two sta-

All possible contingencies which may arise during installation, operation or maintenance, and all details and variations of this equipment do not purport to be covered by these instructions. If further information is desired by purchaser regarding this particular installation, operation or maintenance of this equipment, the local ABB Inc. representative should be contacted.

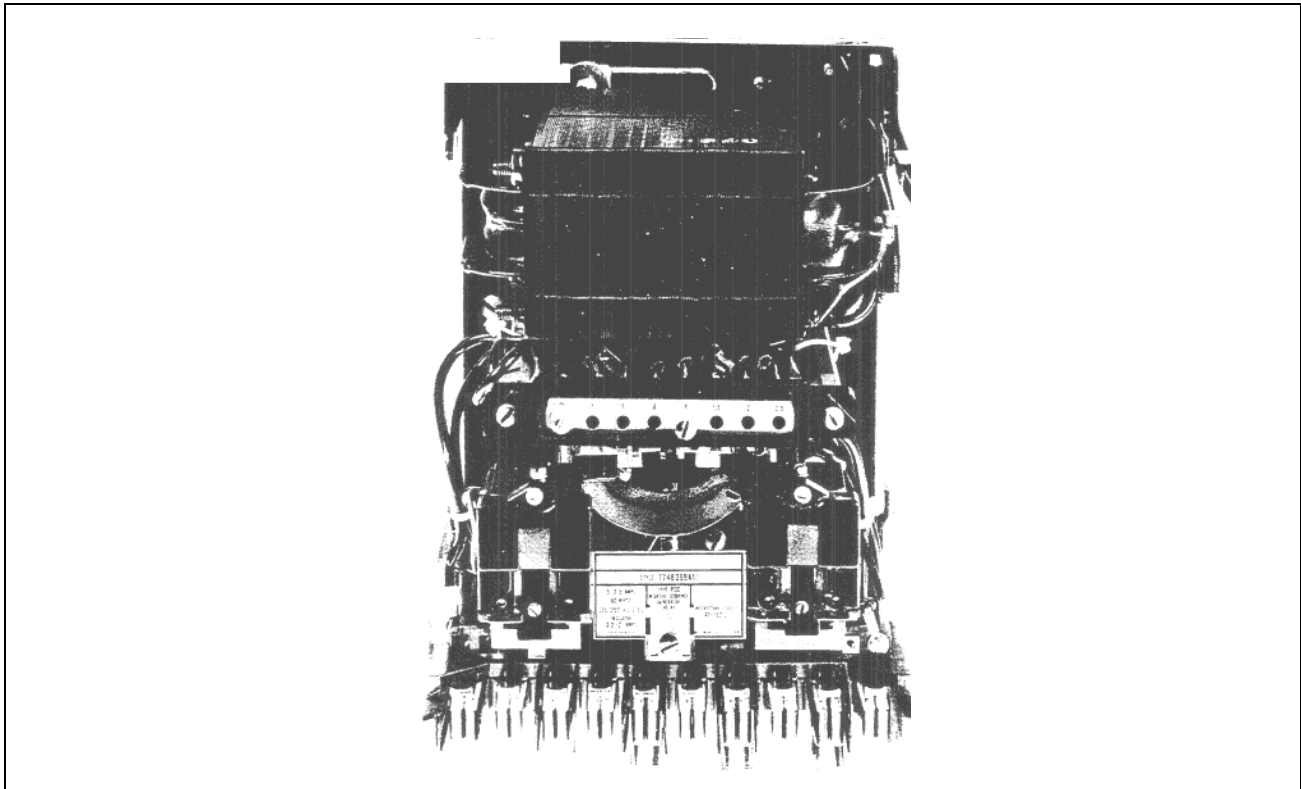

Figure 1 .Type POQ Relay in FT-21 case (Front View)

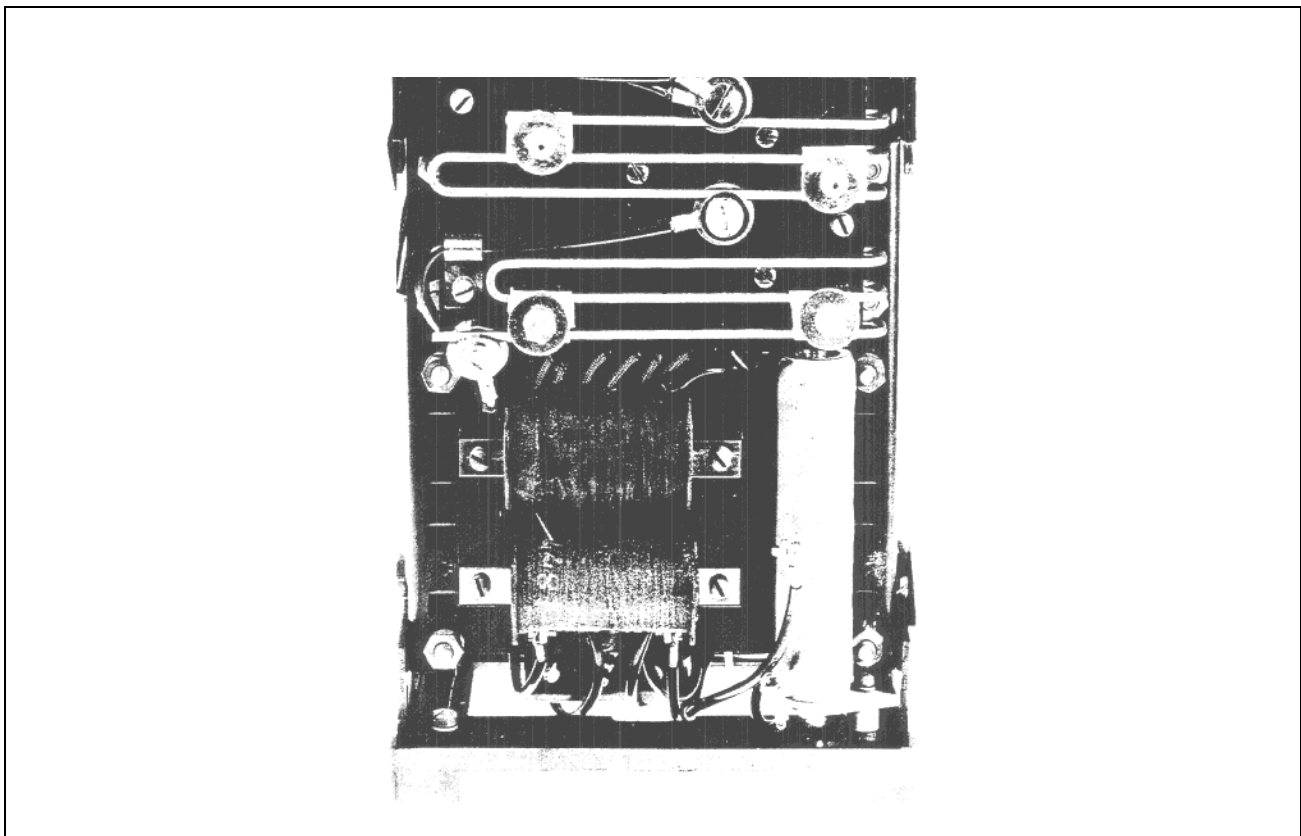

Figure 2 .Type POQ Relay in FT-21 case (Rear View)

tionary contacts, completing the trip circuit. Also during this operation two fingers on the armature deflect a spring located on the front of the switch- which allows the operation indicator target to drop. The target is reset from the outside of the case by a push rod located at the bottom of the cover.

The front spring, in addition to holding the target, provides restraint for the armature and thus controls the pickup value of the switch.

2.4 AUXILIARY SWITCH (CS-1)

The auxiliary switch is similar in construction to the indicating contactor switch except that it has no target.

When the polar unit contacts close, the coil of the auxiliary switch is energized from a battery voltage. The operation of this switch consumes approximately 3/4 cycle, at the end of which time the POQ Unit trip circuit will be completed if the polar unit contacts remain closed. The auxiliary switch is incorporated in the relay design to give an overall shockproof quality not obtainable with an extremely sensitive high speed element. If the polar unit contacts are closed momentarily due to an accidental mechanical shock to the switchboard panel, they will not remain closed for sufficient time to pick up the auxiliary switch to complete the trip circuit.

3.0 CHARACTERISTIC

The type POQ negative sequence relay is available in two ranges with the following negative sequence current taps:

RANGE	TAPS							
0.5-2.5	.5	.6	.8	1.0	1.5	2.0	2.5	
0.2- 1.0	.2	.25	.3	.4	.6	.8	1.0	

These taps represent the negative sequence current values required to operate the relay. At these values of negative sequence current the polar unit will close its contacts to pickup the time delay switch.

Typical burdens and thermal ratings are shown in Table 1.

3.1 TRIP CIRCUIT

The main contacts will safely close 30 amperes at 250 volts dc and the seal-in contacts of the indicating

contactor switch will safely carry this current long enough to trip a circuit breaker.

The indicating contactor switch has two taps that provide a pickup setting of 0.2 or 2 amperes.

3.2 TRIP CIRCUIT CONSTANT

Indicating Contactor Switch (ICS)
0.2 ampere tap 6.5 ohms dc resistance
2.0 ampere tap 0.15 ohms dc resistance

4.0 SETTING THE RELAY

4.1 POQ UNIT

Set the tap to the position which gives the desired negative sequence current pickup.

4.2 INDICATING CONTACTOR SWITCH (ICS)

No setting is required on the ICS unit except the selection of the 0.2 to 2.0 ampere tap setting. This selection is made by connecting the lead located in front of the tap block to the desired setting by means of the connecting screw.

5.0 INSTALLATION

The relays should be mounted on switchboard panels or their equivalent in a location free from dirt, moisture, excessive vibration and heat. Mount the relay vertically by means of the rear mounting stud or studs for the type FT projection case or by means of the four mounting holes on the flange for the semi-flush type FT case. Either the stud or the mounting screws may be utilized for grounding the relay. External toothed washers are -provided for use in the locations shown on the outline and drilling plan to facilitate making a good electrical connection between the relay case, its mounting screws or studs, and the relay panel. Ground Wires are affixed to the mounting screws or studs as required for Poorly grounded or insulating panels. Other electrical connections may be made directly to the terminals by means of screws for steel panel mounting or to the terminal stud furnished with the relay for thick panel mounting. The terminal stud may be easily removed or inserted by locking two nuts on the stud and then turning the proper nut with a wrench.

For detail information on the FT case refer to Instruction Leaflet 41-076.

Table 1:
OVERCURRENT UNIT BURDEN AND TERMINAL RATING

Phase	Continuous Rating-Amps	One Second Rating-Amps	Watts at 5 Amps	Volt Amps. at 5 Amps	Power Factor Angle
1	5	100	5.3	5.3	0°
2	5	100	0.0	.98	90° Lag
3	5	100	4.0	7.25	56° Lag

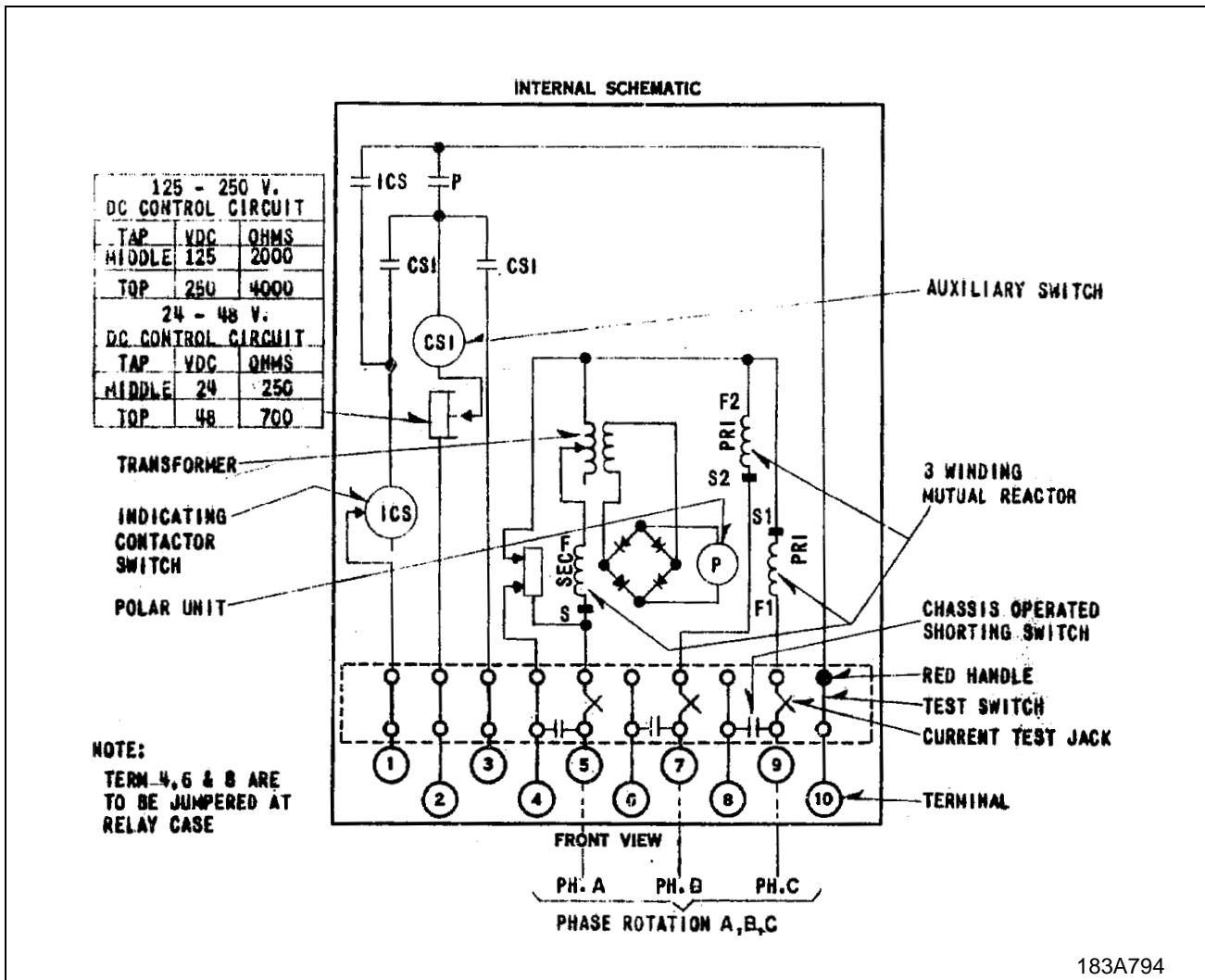

Figure 3. Internal Schematic of the Type POQ Relay in FT-21 Case

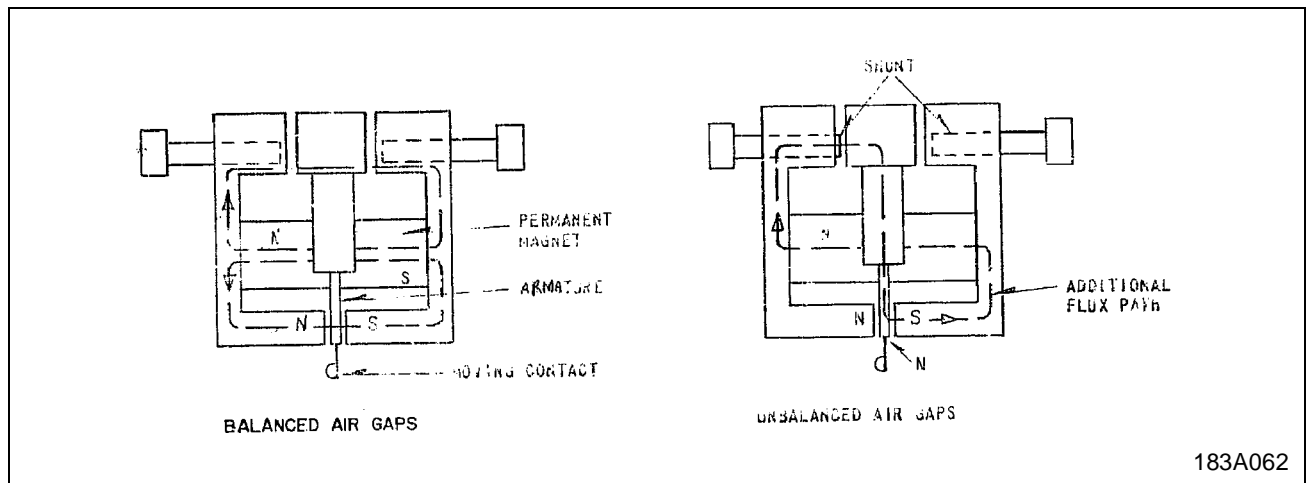

Figure 4 .Polar Unit Perament Magnet Flux Paths

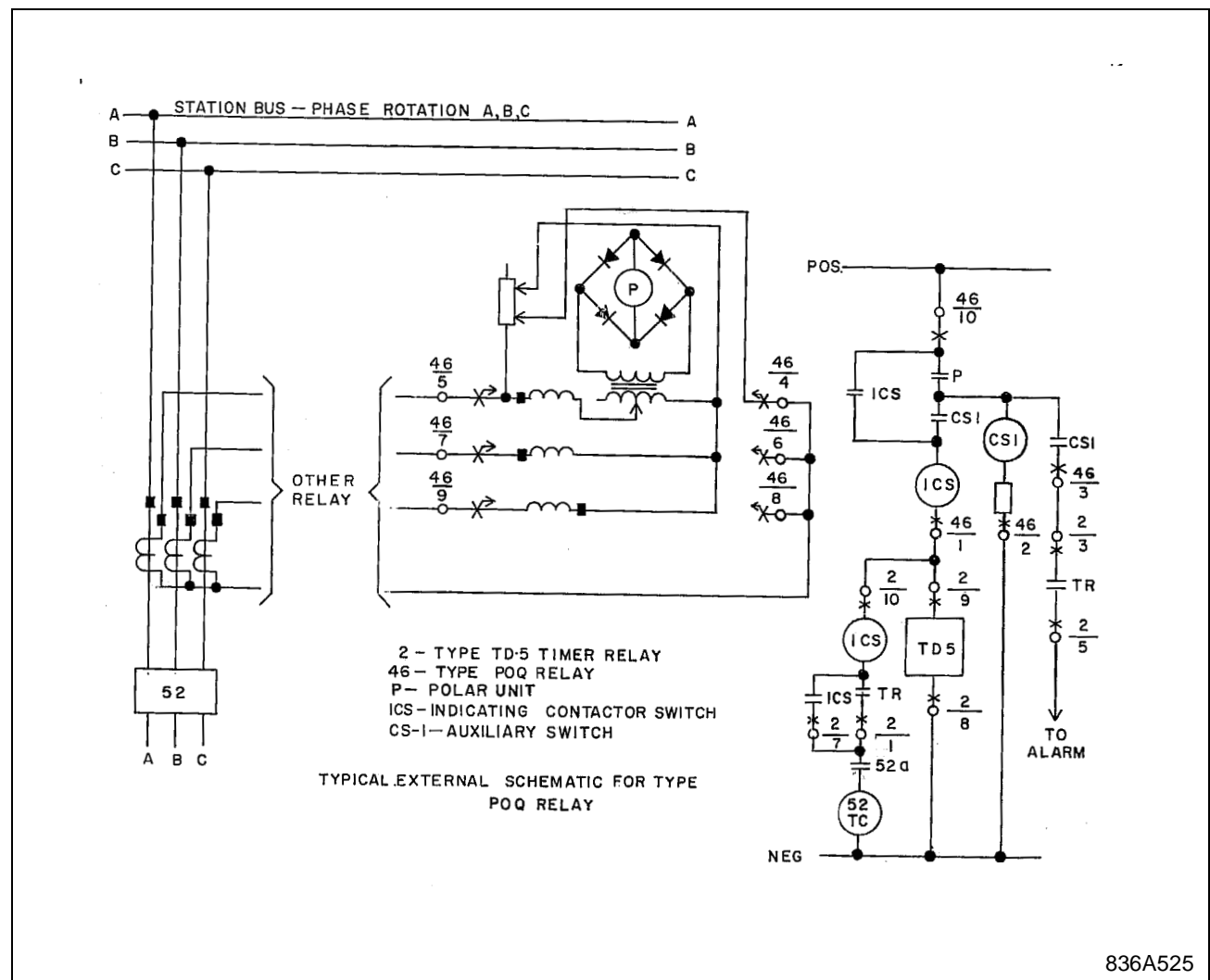

Figure 5. External Schematic for Type POQ Relay

6.0 ADJUSTMENTS & MAINTENANCE

The proper adjustments to insure correct operation of this relay have been made at the factory and should not be disturbed after receipt by the customer. If the adjustments have been changed, the relay taken apart for repairs, or if the desired to check the adjustments at regular maintenance periods, the instructions below should be followed.

6.1 ACCEPTANCE TESTS

The following tests are recommended when the relay is received from the factory to insure that the relay is in proper working order.

6.2 POQ UNIT

Set the relay on the 1 amp tap and apply 1.73 amperes single phase to terminals 5 and 7. The polar unit should close its contacts within plus or minus 10 per cent of this value. These contacts should also close when the current is applied to terminals 5 and 9 and to 7 and 9.

Check other taps as per Table 2.

Table 2:

3.5 - 2.5 Ampere Range		0.2 - 1.0 Ampere Range	
Tap	Amperes Trip Current	Tap	Amperes Trip Current
.5	0.78 - 0.95	.2	0.31 - 0.38
.6	0.93 - 1.14	.25	0.39 - 0.48
.8	1.25 - 1.52	.3	.047 - 0.57
1.0	1.56 - 1.90	.4	0.62 - 0.76
1.5	2.34 - 2.85	.6	0.93 - 1.14
2.0	3.11 - 3.81	.8	1.25 - 1.52
2.5	3.89 - 4.76	1.0	1.56 - 1.90

6.3 INDICATING CONTACTOR SWITCH (ES)

Close the contacts of the polar unit and the auxiliary switch and pass sufficient dc through terminals 1 and 10 to close the contacts of the ICS. This value of current should not be greater than the particular ICS tap settings being used. The operation indicator target should drop freely.

6.4 AUXILIARY SWITCH (CS-1)

Close the contacts of the polar unit and apply 60 per cent dc voltage to terminals 2 and 10. The auxiliary switch should pick up.

6.5 ROUTINE MAINTENANCE

All the relays should be inspected periodically and the time of operation should be checked at such time intervals as may be dictated by experience to be suitable to the particular application.

All contacts should be cleaned periodically. A contact burnisher S#182A836H01 is recommended for this purpose. This use of abrasive material for cleaning contacts is not recommended, because of the danger of embedding small particles in the face of the soft silver and thus impairing the contact.

6.6 RECTIFIER BRIDGE ASSEMBLY

To check for diode shorts or opens remove polar unit coil connection and measure each diode with an ohmmeter for forward and reverse characteristics.

7.0 CALIBRATION

Use the following procedure for calibrating the relay if the relay has been taken apart for repairs or the adjustments disturbed. This procedure should not be used until it is apparent that the relay is not in proper working order. (See "Acceptance Check.")

7.1 NEGATIVE SEQUENCE CURRENT FILTER

To adjust the filter resistor tap for no response to positive sequence current, remove the relay from its case and proceed as follows:

- a. Remove tap screw from POQ unit.
- b. Apply 10 amps single phase current in to terminal 7 and out 5.
- c. With low reading type voltmeter, measure and record the voltage across terminal 5 and the tap plate of the POQ unit.
- d. Now measure voltage across terminal 5 and the top filter resistor screw connection (refer to Figure 2). Adjust this connection until the voltmeter reads 1.73 times the reading obtained in part c.

To adjust the filter resistor tap for no response to zero sequence currents, remove tap Screw from POQ unit. Pass 10 amperes into terminal 7, 5 amperes into terminal 5 and out terminal 4 per Fig. 6. Connect a voltmeter between the top and bottom filter resistor connection (Fig. 2). Adjust the middle connection until the voltmeter reads a minimum.

7.2 POQ UNIT

1. **Contacts** - Allow the armature rivet to strike the right hand pole face and bring up the stationary contact screw until the contact circuit just makes. Give the stationary contact screw an additional one-half to one turn before locking it in place with the lock nut provided. With the contacts in the 'closed position, bring up the backstop screw until it just touches the moving contact. Then back off one turn and lock in place.
2. **Minimum Trip Current** - Place the tap screw in 1 ampere tap.

There is a residual magnetism effect in this relay; therefore, first apply a polarizing current of 30 amperes between terminal 7 and 4. Place both shunts all the way in and adjust the shunts such that with current passed through terminal 7 and 5, the polar unit will pickup at 1.73 amperes and dropout at 0.865 amperes or higher. Referring to Fig. 1, drawing out the left hand shunt increases the amount of current required to close the relay contacts. Conversely, drawing out the right hand shunt decreases the amount of current required to trip the relay. It will usually be possible to set the relay to the desired tripping value by leaving the right hand shunt at the extreme "in" position and make all adjustments with the left hand shunt.

The relay should then be momentarily subjected to a current of 30 amperes. Minimum trip should then be checked and the relay readjusted to, trip at 1.73 amperes. This process should be repeated back and forth until there is no change in the minimum trip current.

3. Indicating Contactor Switch (ICS)

Close the main relay contacts and pass sufficient dc current through the trip circuit to close the contacts of the ICS. This value current should be not greater than the particular ICS tap setting being used. The operation indicator target should drop freely.

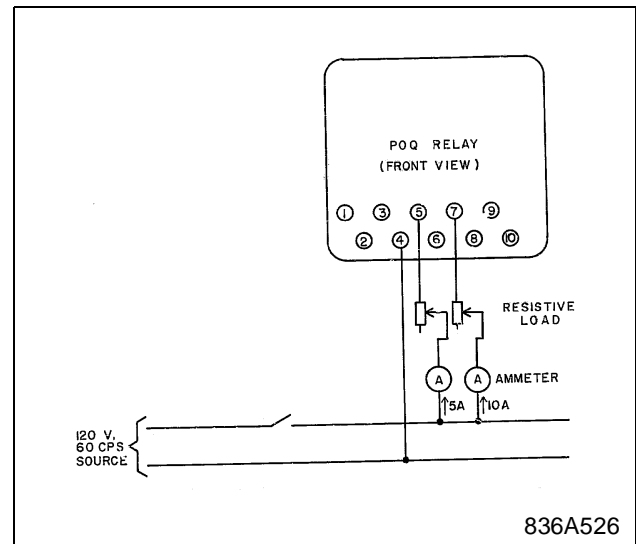

Figure 6. Test connectins for the Type POQ Relay

The contact gap should be approximate .047" between the bridging moving contact and the adjustable stationary contacts. The bridging moving contact should touch both stationary contacts simultaneously.

4. Auxiliary Contactor Switch (CS-1)

Close the polar unit contact and apply 60 per cent dc voltage to terminals 2 and 10. CS-1 should pick up.

The contact gap should be approximately .047" between the bridging moving contact and the adjustable stationary contacts. The bridging Moving contacts should touch both stationary contacts simultaneously.

8.0 RENEWAL PARTS

Repair work can be done most satisfactorily at the factory. However, interchangeable parts can be furnished to the customers who are equipped for doing repair work. When ordering parts, always give the complete nameplate data.

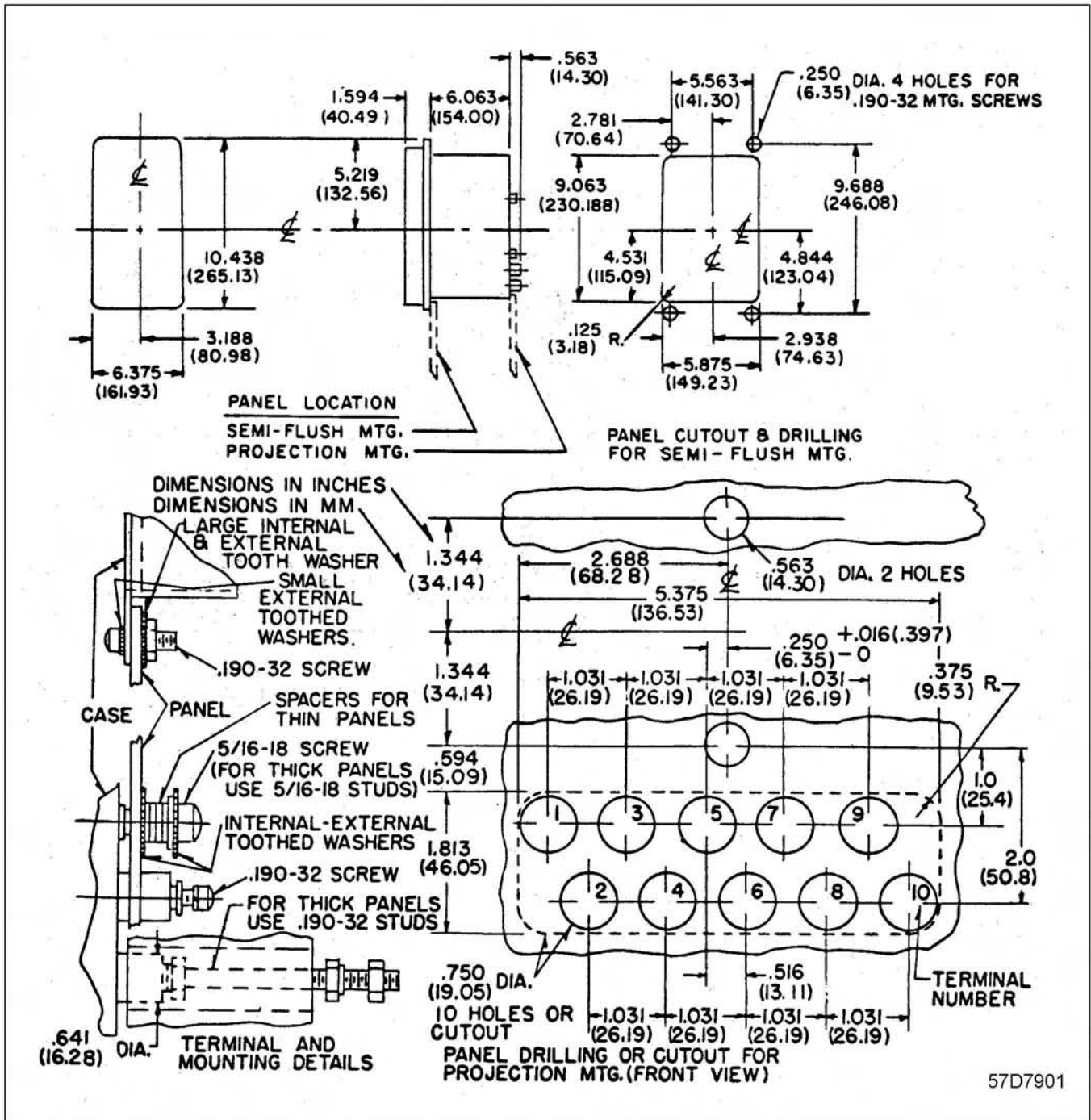

Figure 7 .Outline and Drilling Plan for the Type POQ Relay in the FT-21 Case



ABB Inc.
 4300 Coral Ridge Drive
 Coral Springs, Florida 33065
 Telephone: +1 954-752-6700
 Fax: +1 954-345-5329
 www.abb.com/substation automation