

MEDIUM VOLTAGE PRODUCTS – CATALOGUE TK 541/06

UFES™

Ultra-Fast Earthing Switch

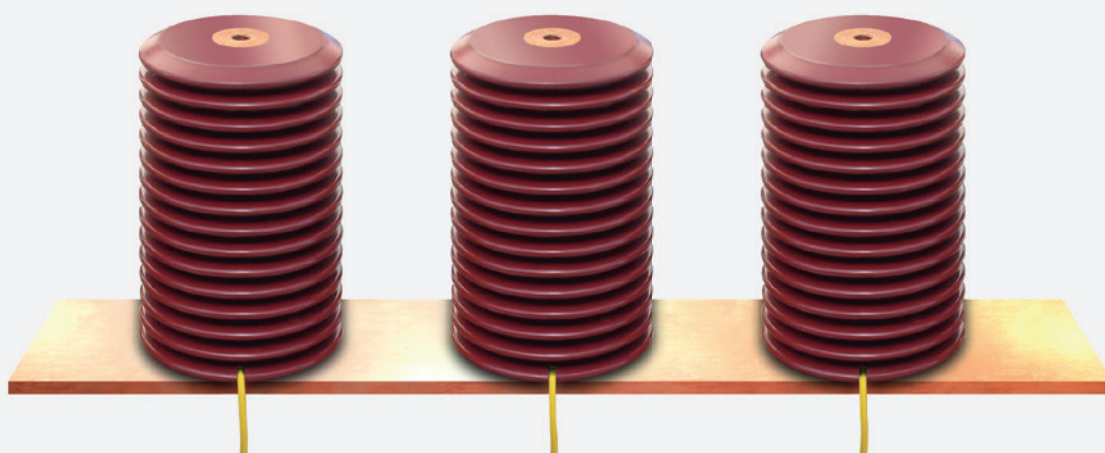

—

The influence of high thermal and mechanical stresses in the event of an internal arc fault can be drastically reduced by the use of an active arc fault protection system. In contrast to pure overcurrent protection, such a system specifically detects an internal arc fault and brings it to extinction within shortest time. The faster an arc fault is suppressed, the less damage can be expected in the switchgear system.

Table of contents

006	Introduction
007	Description of function
008–009	System components
010–013	Functionality
014–018	Applications
019–020	General notes on installation
021–023	Technical data
024–025	Dimensions
026–028	Circuit diagrams
029–031	Ordering details
032	A1 Guideline for the determination of the current treshold

UFES: Benefits for a broad range of market segments



Safety



Reliability



Productivity

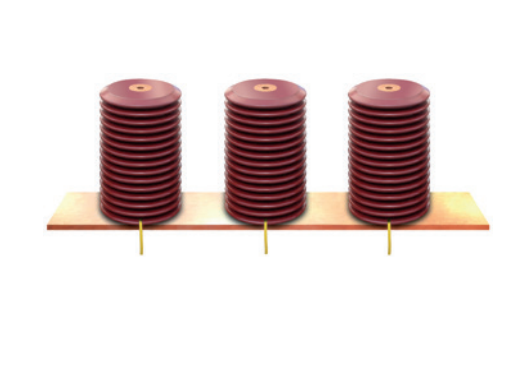

Active internal arc protection



Greatly increased operator safety

... by effective prevention of hazardous situations

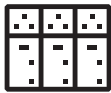

Minimized damage of electrical equipment and their environment

... due to ultra-fast arc fault mitigation



Drastic reduction in downtimes & repair costs

... to avoid significant economic losses and preserve greatest possible competitiveness



Application of active protection concepts for pressure sensitive environment

... e.g. where gas ducts are not applicable

S³ – Speed, Safety, Savings

The Ultra-Fast Earthing Switch of type UFES is a combination of devices consisting of an electronic device and the corresponding primary switching elements which initiate a 3-phase short-circuit to earth in the event of a fault. The extremely short switching time of the primary switching element, less than 1.5 ms, in conjunction with the rapid and reliable detection of the fault, ensures that an arc fault is extinguished almost immediately after it arises. With a total extinguishing time of less than 4 ms after detection, an active protection concept with the Ultra-Fast Earthing Switch enables switchgear installations to achieve a highest possible level of protection for persons and equipment.

With the extremely rapid intervention provided by the Ultra-Fast Earthing Switch, ABB has succeeded in increasing active arc fault protection for switchgear systems to a maximum. The compact system can in principle be used in any new or existing short-circuit proof switchgear system with rated voltages up to 40.5 kV and rated short time currents up to 100 kA.

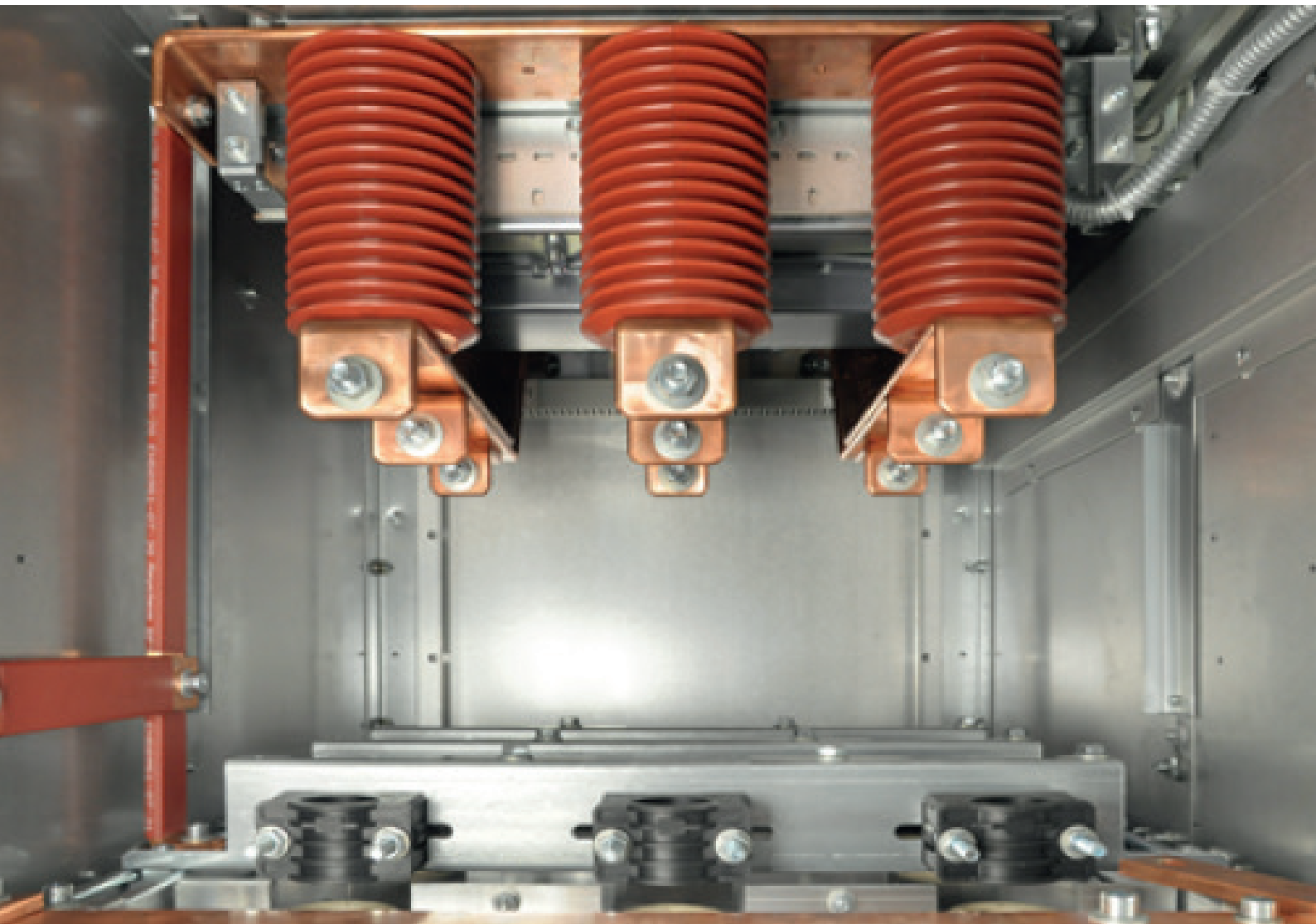

1 Description of function

1.1 Function

The enhanced system and operator protection provided by the Ultra-Fast Earthing Switch is implemented by consciously creating a 3-phase short-circuit to earth in the event of an arc fault.

The tripping of the Ultra-Fast Earthing Switch first requires the rapid and reliable detection of an arc fault in a defined protection zone of the switchgear system. The specific fault is detected either by external arc fault detection systems which are combined with a UFES electronic tripping unit of

type QRU100, or alternatively by an expandable UFES electronic detection and tripping unit type QRU1. If the criteria / conditions for a tripping are fulfilled, the UFES electronics issues a trip signal to the 3 primary switching elements (PSE), which then establish a 3-phase, metallic short-circuit at their point of installation.

As this short-circuit is of considerably lower impedance than the fault, the fault current commutates from the arc to the defined short-circuit created by the PSE, causing the arc fault voltage to break down and the arc to be extinguished almost immediately. The resulting controlled flow of earth fault current is then finally shut down by the feeder circuit-breaker.

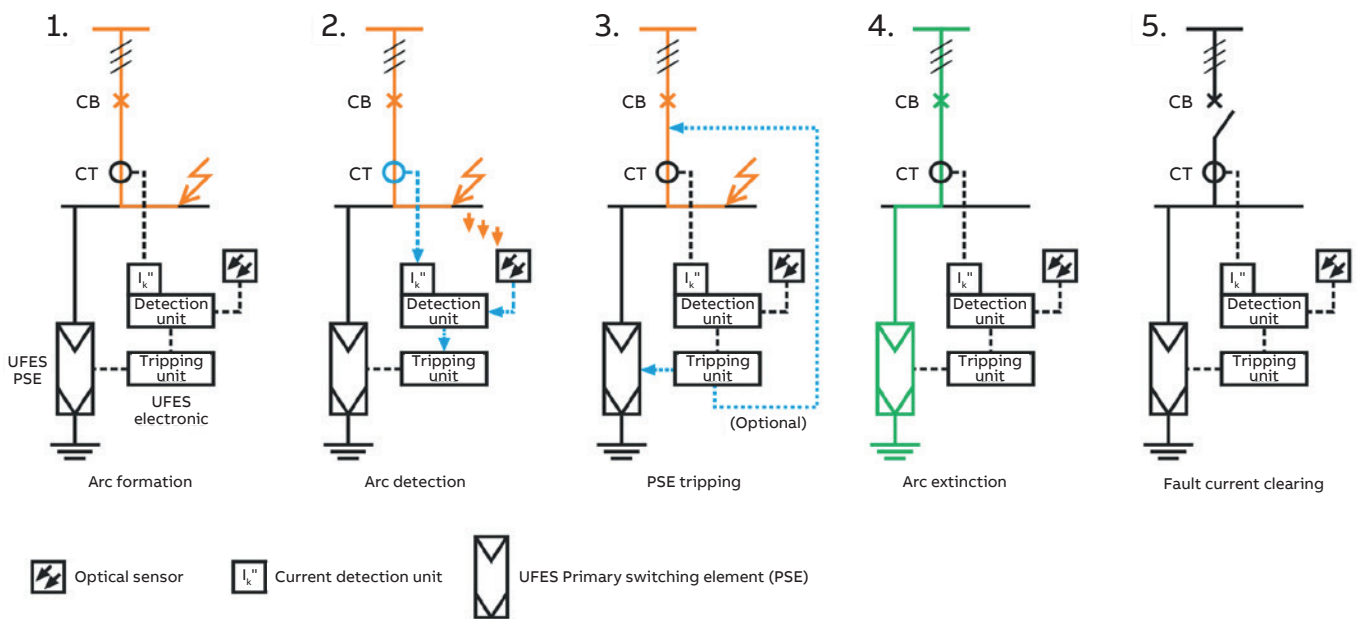
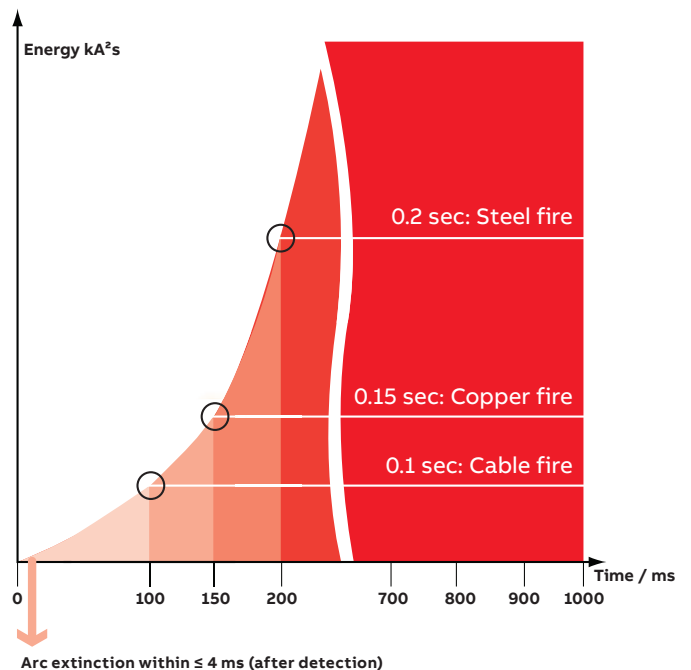
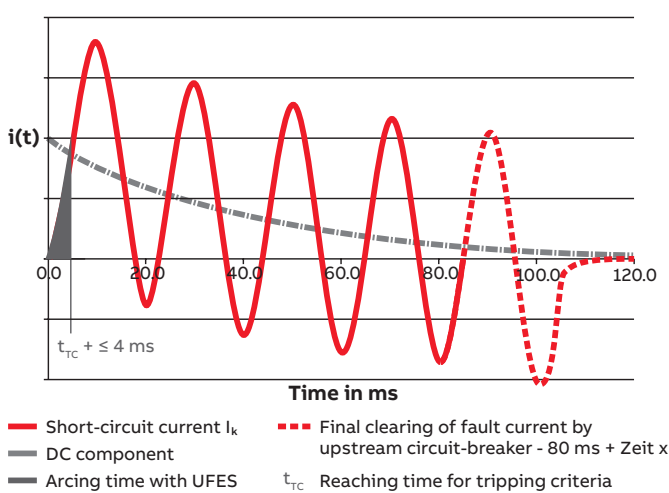

Fig. 1.1-1 Diagrams showing the function sequence



Figs. 1.1-2 – 1.1-3 Drastic reduction of the possible energy release by ultra-fast extinction of the arc

2 System components

2.1 Ultra-Fast Earthing Switch

The structure of the Ultra-Fast Earthing Switch type UFES consists of a device-specific electronics as well as the 3 primary switching elements (PSE). These elements, including made-up trip cables, form the UFES kit.

The UFES electronics is available in 2 designs. The electronic tripping unit (TU) type QRU100 uses only external detection units for the monitoring of the protected zone. The electronic detection and tripping unit (DTU) type QRU1 on the other hand, provides an expandable complete solution with internal light and current detection, which is able to protect small protection zones without any additional devices.



Fig. 2.1-1 Electronic tripping unit type QRU100

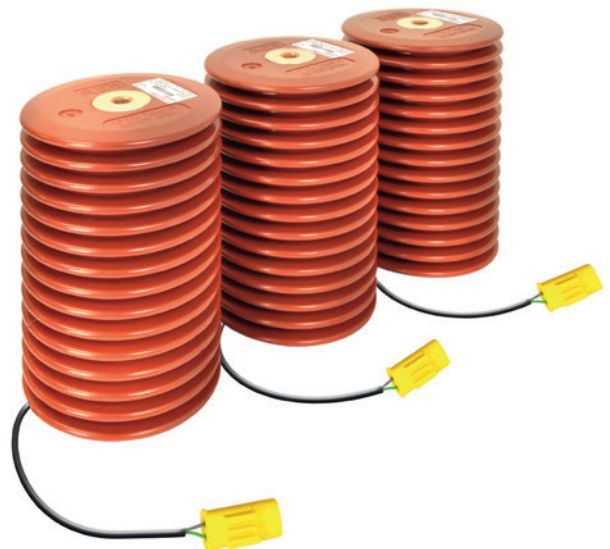

Fig. 2.1-3 Primary switching element type U1



Fig. 2.1-2 Electronic detection and tripping unit type QRU1



Fig. 2.1-4 Trip cables (UFES electronics → PSE)

2.2 Accessories and external components

2.2.1 UFES kit with TU type QRU100

The complete detection of an internal arc fault is done by means of external detection units. In this context, the TU suits ideal for the connection to the ABB arc protection system type REA. For this purpose compatible and accordingly tested interfaces are available.

Detailed information regarding the characteristics of the REA arc protection systems can be found in the corresponding technical catalogues.

2.2.2 UFES kit with DTU type QRU1

The optical detection of the individual switchgear system compartments is done by means of single lens sensors, which are directly connected to the DTU.

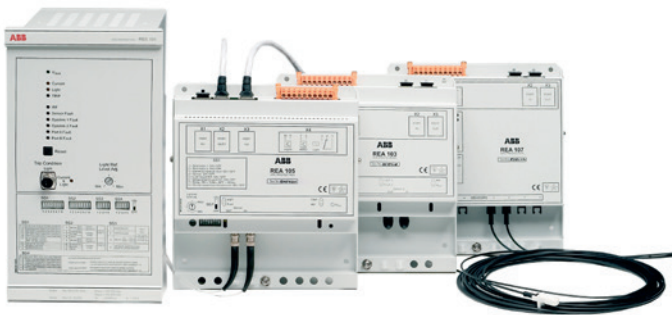

Fig. 2.2.1-1 ABB Arc protection system type REA

Furthermore, the system can be expanded with the ABB arc guard type TVOC-2 for applications in which more than 9 switchgear system compartments are to be optically monitored. The DTU of the Ultra-Fast Earthing Switch provides 5 dedicated inputs for connection of these external devices. Herewith up to 150 lens sensors more can be integrated in the UFES protection system (see also chapter 4.2.1).

Detailed information regarding the characteristics of the TVOC-2 arc guard monitor units can be found in the corresponding technical catalogues.

2.3 Test plug

By usage of the test plug, the DTU / TU can be subjected to a functional testing in "Operation" mode. The test plug here conduces the optical and acoustic signalization of the 3 tripping pulses.



Fig. 2.2.2-1 ABB Arc Guard type TVOC-2



Fig. 2.2.2-2 Lens sensor for DTU

3 Functionality

3.1 UFES electronics

In the development of the electronics of the Ultra-Fast Earthing Switch, the focus was consciously directed at the fundamental purpose of the application, namely the effective protection of the system by fast and reliable detection and processing of the input signals, as well as a short reaction time for triggering of the connected switching devices in the event of a fault. The circuit is completely implemented in fast analog technology, with exclusively hardware components responsible for the entire safety functionality.

3.1.1 Electronic tripping unit (TU) type QRU100

With the electronic tripping unit type QRU100, the Ultra-Fast Earthing switch suits for the connection of external arc protection systems. In such an application, the complete detection of an arc will be covered by the external system, which will send a trip signal to the Ultra-Fast Earthing Switch in case of an arc fault. This results in numerous opportunities for the creation of new protection concepts as well as for the retrofit of existing systems.

Functionality

The TU type QRU100 is the interface between external arc detection units and the UFES primary switching elements (PSE). For this purpose the electronics provides 2 optolink and 2 high-speed input (HSI) terminals. While the HSI are universal interfaces, the optolink inputs are designed for the connection of the REA system only. In a test mode, the functions of the settings and detection components can be checked without tripping the primary switching elements (PSE). Inadvertent switchover into test mode is prevented by a lock switch. The functions of the device relevant to safety are constantly self-monitored and can be polled via signals.

Optolink

Via this signal transfer fiber connector the TU can be started by external detection units of the ABB arc fault protection system type REA. Besides of a very fast connection, this interface provides the additional advantage of continuous monitoring of the used fiber connection (optolink supervision).

Configuration

The single inputs of the electronics can be enabled separately with DIP switches. Furthermore there is the possibility to combine specific inputs logically to a trip condition.

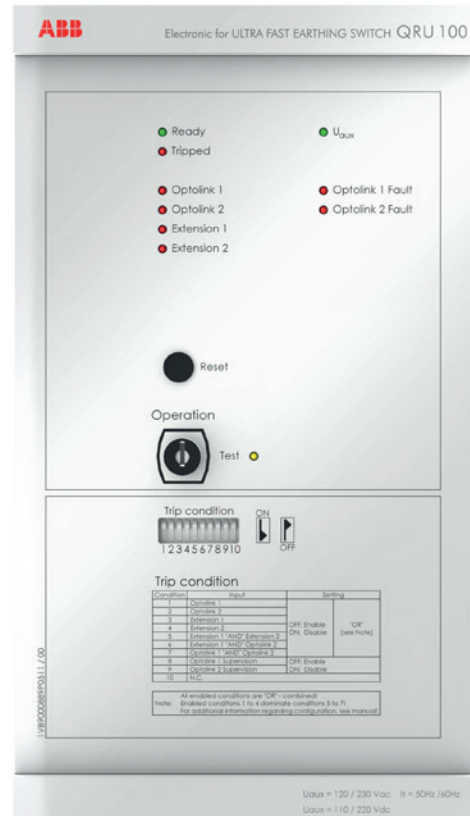

Fig. 3.1.1-1 TU front view with controls and displays

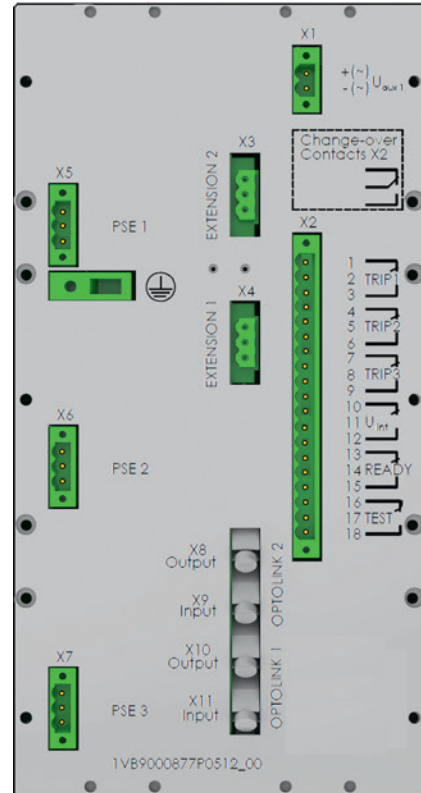

Fig. 3.1.1-2 TU rear view

As far as possible, all connections are designed as plug-in terminal strips.

Available connections:

- X1 Auxiliary voltage supply
- X2 6 floating signal contacts
- X3, X4 2 x High-speed inputs (HSI)
- X5 - X7 3 x PSE
- X8 - X11 2 x Optolink interface

3.1.2 Electronic detection and tripping unit (DTU) type QRU1

Functionality

The DTU combines continuous light and overcurrent monitoring in a single unit. A configuration logic allows the two parameters to be set and combined in any way. In a test mode, the functions of the settings and detection components can be checked without tripping the PSE. As for the TU type QRU100, the test mode can be activated by means of a lock switch. The functions of the device relevant to safety are constantly self-monitored and can be polled via signals.

Light detection

Light detection is implemented by means of individual lens sensors which are to be installed in the switchgear system compartments and which react to strong increases in light intensity. The light sensors are connected to the DTU by dielectrically sound optical fibre cables. A seven segment display indicates the activated sensor when a fault occurs, thus providing an opportunity for precise fault location. The lens sensors used are fully compatible with the ABB Arc Guard TVOC system.

Current detection

Current detection is performed, for example, using the protection current transformers in the incoming feeder panel of the switchgear section, and these may have a secondary current of 1 A or 5 A. The inputs of this detection unit have a low burden of < 1 VA, and therefore this monitoring circuit can normally be looped into existing protection circuits without problems. If the instantaneous current measured is greater than the response level set, this constitutes the second criteria for reliable fault detection.



On selection of the current transformers to be used, it is to be ensured that they have a sufficiently high overcurrent factor to transmit the selected current threshold level accurately.

→ Detailed information on this aspect can be found in the Appendix A1.

Configuration

All settings for implementation of the desired protection concept can be made in a user-friendly manner with DIP switches on the front of the DTU. This provides an opportunity to link the various detection units for the light and overcurrent parameters in AND/OR logic operations. The required response value for impermissible overcurrent can also be set with a second set of DIP switches.

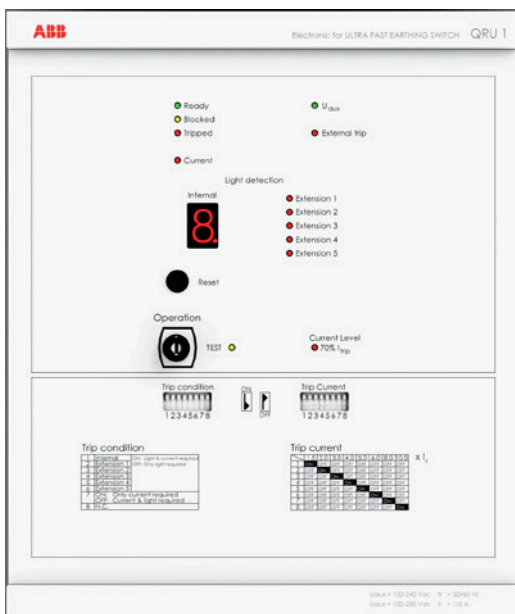

Fig. 3.1.2-1 DTU front view with controls and displays

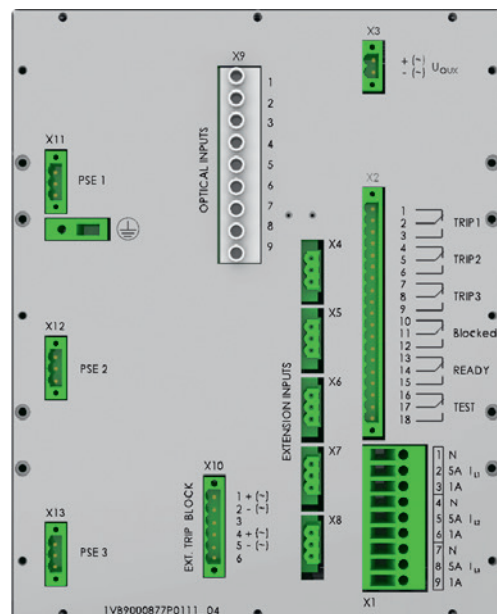

Fig. 3.1.2-2 DTU rear view

As far as possible, all connections are designed as plug-in terminal strips.

Available connections:

- X1 3 current transformers (internal detection)
- X2 6 floating signal contacts
- X3 1 x Auxiliary voltage supply
- X4 - X8 5 extension inputs
- X9 9 optical sensors (internal detection)
- X10 1 x external blocking
- X10 1 x external trip
- X11 3 x PSE

3.2 Primary switching element, type U1

Together with the fundamental requirement for serious arc faults to be rapidly and unequivocally recognized as such, the challenge consists in extinguishing them as quickly as possible. In the Ultra-Fast Earthing Switch, this is performed by three primary switching elements (PSE), which are installed between the live busbar system and earth. The PSE are available for various voltages and currents.

Speed

The PSE provide a major time advantage over arc fault interruption by a circuit-breaker. A vacuum interrupter specially developed for this application in conjunction with a reliable, phase-independent micro gas generator mechanism for energy storage ensure that the switching operation is completed within 1.5 ms.

Switching principle

When tripped, the micro gas generator causes an extremely rapid pressure rise in the piston chamber surrounding it. Propelled in this way, the piston penetrates the lid of the vacuum interrupter at the prepared rupture point, and drives the moving contact, which is at earth potential in its initial position, into the fixed contact socket which is at busbar potential. A firmly latched, undetachable connection is established.

Replacement

As the processes described under “Switching principle” are irreversible, the tripped PSE are to be replaced with new ones after a switching operation.

Handling

No special safety requirements have to be observed for proper handling of the PSE (installation, replacement, storage and dispatch). The installed micro gas generator is encapsulated in the PSE at the works and fitted with a special seal.

In this condition, the switching device meets the requirements of the German Federal Institute for Materials Research, and has received a corresponding approval certificate.

Maintenance

The PSE have a very low maintenance requirement. The external surface of the PSE with its switching contacts and operating mechanism completely embedded in epoxy resin only requires cleaning when heavily soiled, and a replacement of the micro gas generator should be planned after 15 years. This work is to be performed by the manufacturer.

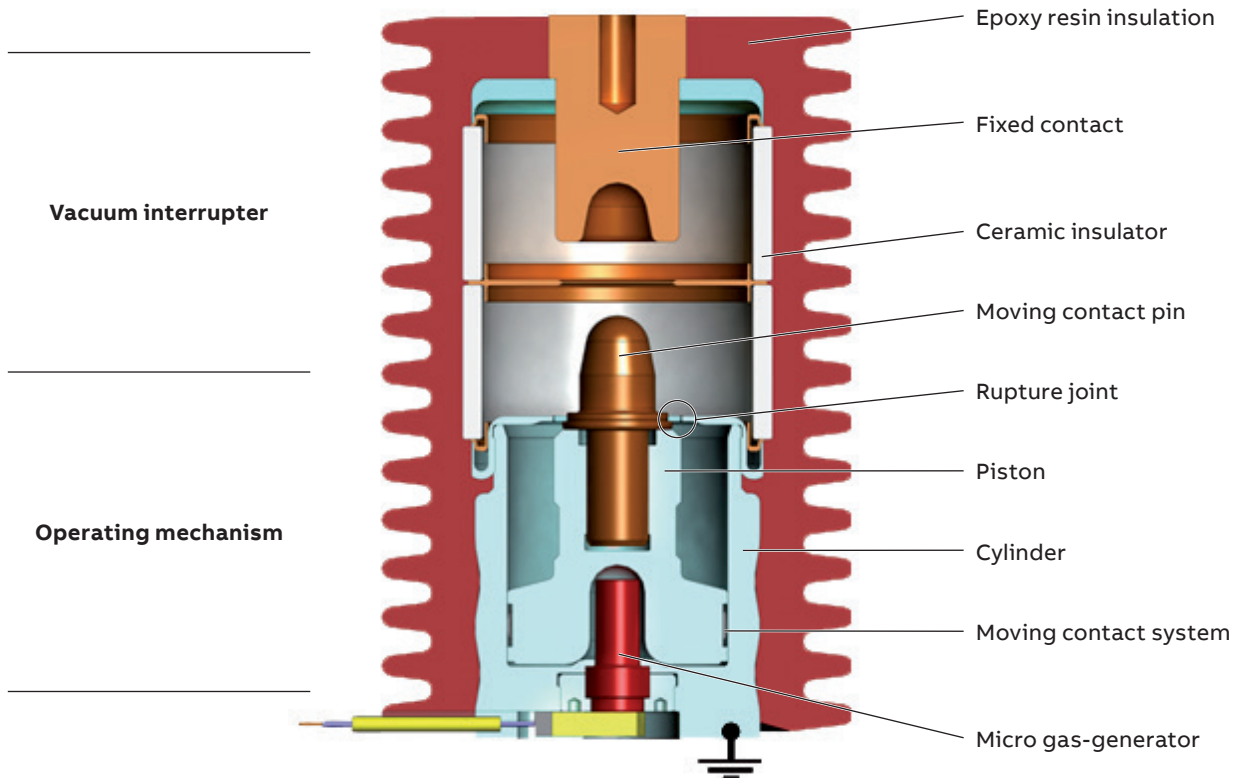

Fig. 3.2-1 Sectional view of PSE Vacuum interrupter and micro gas generator integrated in a compact unit

Flexibility in installation

The compact design of the PSE as individual units with autonomous operating mechanisms provides for flexibility in location and orientation for integration of these units in the switchgear system to be protected. With an overall height of 210 mm, the PSE of type U1 is dimensionally equivalent to a 24 kV pin-type insulator.

Other methods of integration apart from direct installation of the switching device in the switchgear system are also possible. Using a type-tested ABB Service Box with built-in PSEs (figure 3.2-2), it is for example possible to mount the primary part of the Ultra-Fast Earthing Switch on the outside of the switchgear and connect it fixed to the busbar system.

A UFES draw-out unit (figure 3.2-3) provides another option for the integration of the PSE into a panel. In this case, the primary switching elements are installed on ABB truck technology and they are connected to the busbars via a contact system. If empty panels are available, such a “Plug & Play” solution provides an easy way for the retrofit of switchgear.

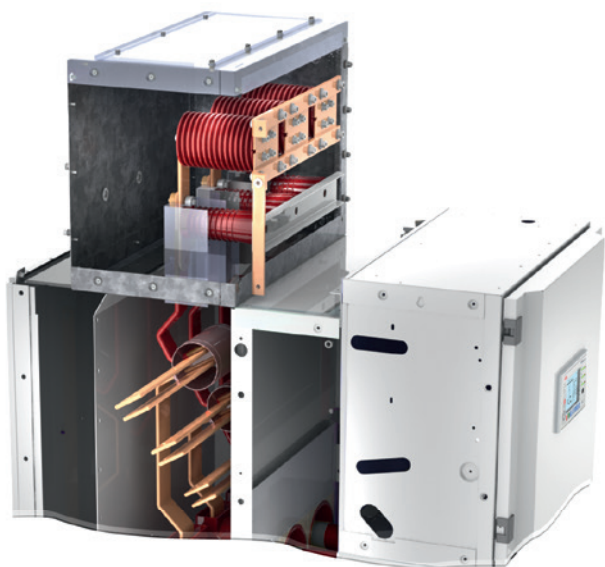

Fig. 3.2-2 ABB Service Box with built-in PSE

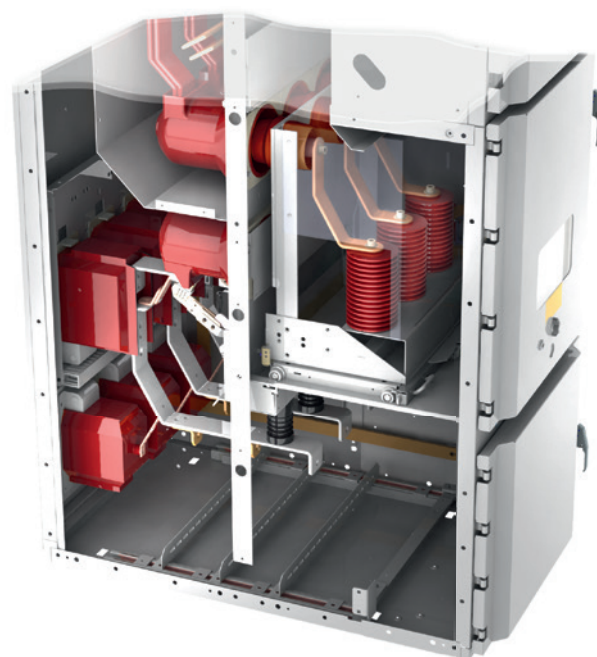

Fig. 3.2-3 Example with UFES draw-out unit

4 Applications

4.1 General

The following illustrations show various ways in which the Ultra-Fast Earthing Switch can be incorporated in a switchgear system. All the examples are described with the electronic tripping unit type QRU100 in combination with the ABB arc protection system type REA. Equally they can also be designed with the electronic detection and tripping unit type QRU1 in combination with the ABB arc guard type TVOC-2.

As there are a large number of customized variants, it is impossible to document every option for application of the Ultra-Fast Earthing Switch. Only the most frequently used applications are therefore presented as examples.

The transformers shown in the examples can also be replaced by generators or any other incoming feed to a switchgear system. Tripping of the primary switching elements (PSE) always takes place in all three phases.

The following characteristics are common to all example applications:

- In the event of an arc fault with exceed of the response values (light and current) / trip conditions the UFES electronics will trip.
- The three PSE create a 3-phase short-circuit to earth at the point of installation and the arc fault in the monitored protection zone of the switchgear is extinguished immediately.
- The fault current is finally switched off by the feeder circuit-breakers. These circuit-breakers can also be triggered directly by the UFES electronics or by the external detection units to shorten the breaking time.

Requirements for the application

- The system and the system components have to be short-circuit proof.
- In applications where the incoming transformer and the incoming circuit-breaker are connected by means of phase segregated copper connections with a short length, the annex M of IEC 62271-100 is applicable.

4.2 UFES + REA

The 2 available interfaces on the QRU100, High-speed input (HSI) and Optolink, suit ideal for the connection of the ABB arc protection system type REA.

The REA arc protection system is a fast and flexible configurable system for switchgear. Just like the UFES electronic detection and tripping unit type QRU1, the REA system detects an arc based on light and current monitoring.

For the optical monitoring 2 types of sensors are used

1. Line sensors, which detect the light over the complete length of a fiber
2. Lens sensors, typically to be installed in each individual switchgear compartment

As soon as an arc is identified as such, the REA system sends a disconnect signal to the circuit-breakers which are feeding the fault. In combination with the Ultra-Fast Earthing Switch, a trip signal of the REA system can be send directly to the Ultra-Fast Earthing Switch via the optolink interface.

The individual modules of the REA system

1. Main module REA101 – Stand-alone relay, providing optical detection by means of a line sensor and internal current detection.
2. Extension module REA103 – Extension of the optical detection with additional line sensors.
3. Extension module REA105 – Extension of the optical detection with an additional line sensor. Furthermore equipped with own high-speed outputs for applications where higher selectivity is required.
4. Extension module REA107 – Extension of the optical detection with additional 8 lens sensors.

Detailed information regarding the characteristics of the REA arc protection system, as well as further example applications can be found in the corresponding technical catalogues.

4.5 Example application 3 – Switchgear system with two incoming feeders and two coupled protection zones

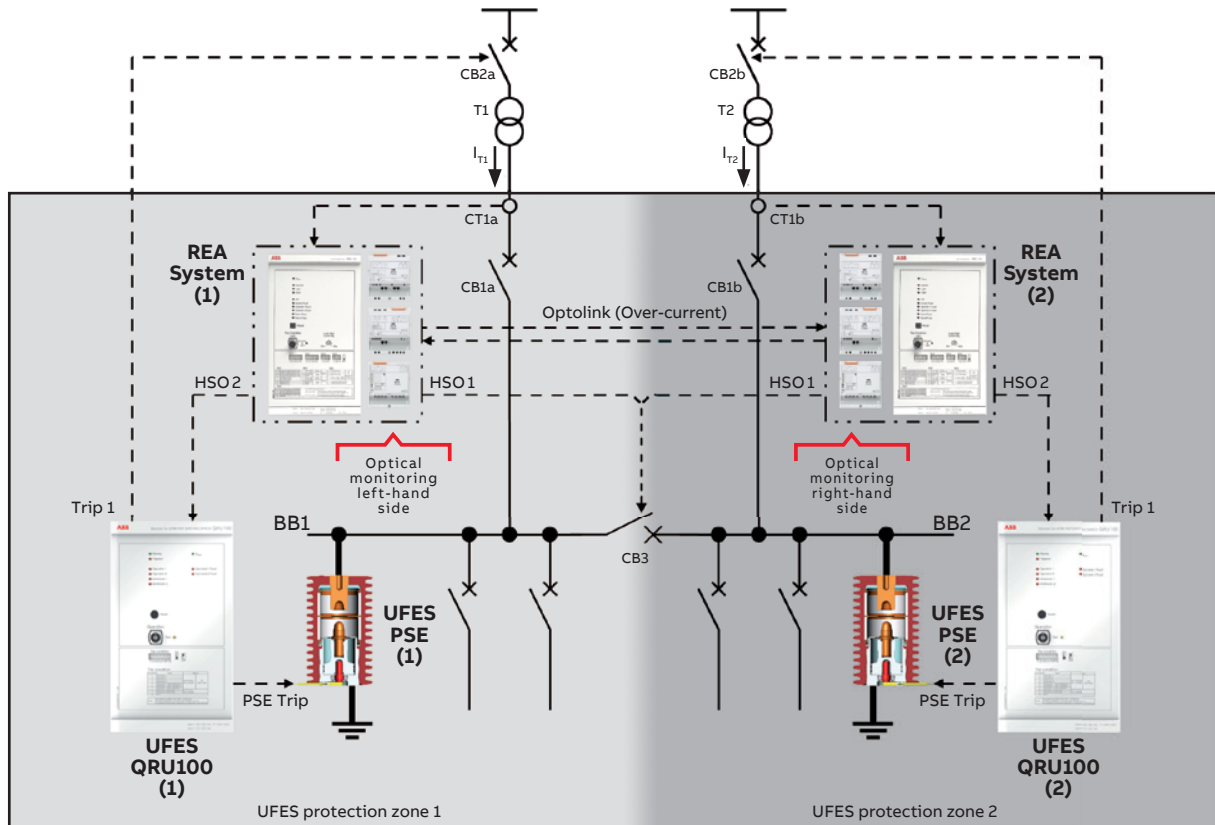

Fig. 4.5-1

This switchgear system is supplied by two transformers. It has two separate busbar sections BB1 and BB2, which can be connected together via longitudinal bus coupler (CB3).

Since each busbar section can also be operated independently, one Ultra-Fast Earthing Switch has to be considered for each bus bar section. The respective three PSE are connected directly to the left hand side busbar and right hand side busbar.

Tripping of the Ultra-Fast Earthing Switches is selective, i.e. UFES 1 is only activated when there is a fault in the left-hand switchgear system with BB1, and UFES 2 only protects the right-hand switchgear system with BB2. In this example the UFES electronics is tripped by the HSO (high-speed output) of the REA system.

Light selective protection

The REA detection system dedicated to UFES 1 is tripped by the light sensors in the left-hand switchgear system with BB1 and by a co-occurring over-current I_{T1} and/or I_{T2} . Analogous the REA detection system dedicated to UFES 2 is tripped by the light sensors in the right-hand switchgear system with BB2 and also by a co-occurring over-current I_{T1} and/or I_{T2} .

Both REA detection systems exchange the over-current information of the left-hand feeder as well as of the right-hand feeder with each other.

In the event of an arc fault in the area of switchgear system BB1 which exceeds the setpoints for summation current I_s and light in switchgear system BB1, UFES 1 trips. The three PSE on busbar BB1 short-circuit the three phases to earth and the arc in the area of switchgear system BB1 is extinguished immediately. At the same time, circuit-breakers CB2a and CB3 receive an OFF command from the TU and the REA system.

If the fault is located behind circuit-breaker CB1a (as seen from the transformer), the three-phase short-circuit generated by the three PSE and the faulty part of the switchgear are switched off by the circuit-breakers CB1a and CB3. If the arc fault occurs in the termination area of the incoming feeder panel for BB1, it is switched off by circuit-breaker CB2a.

The same applies accordingly to the right-hand switchgear system with BB2.

4.6 Example application 4 –
Open switchgear system with two incoming
feeders and double busbar system

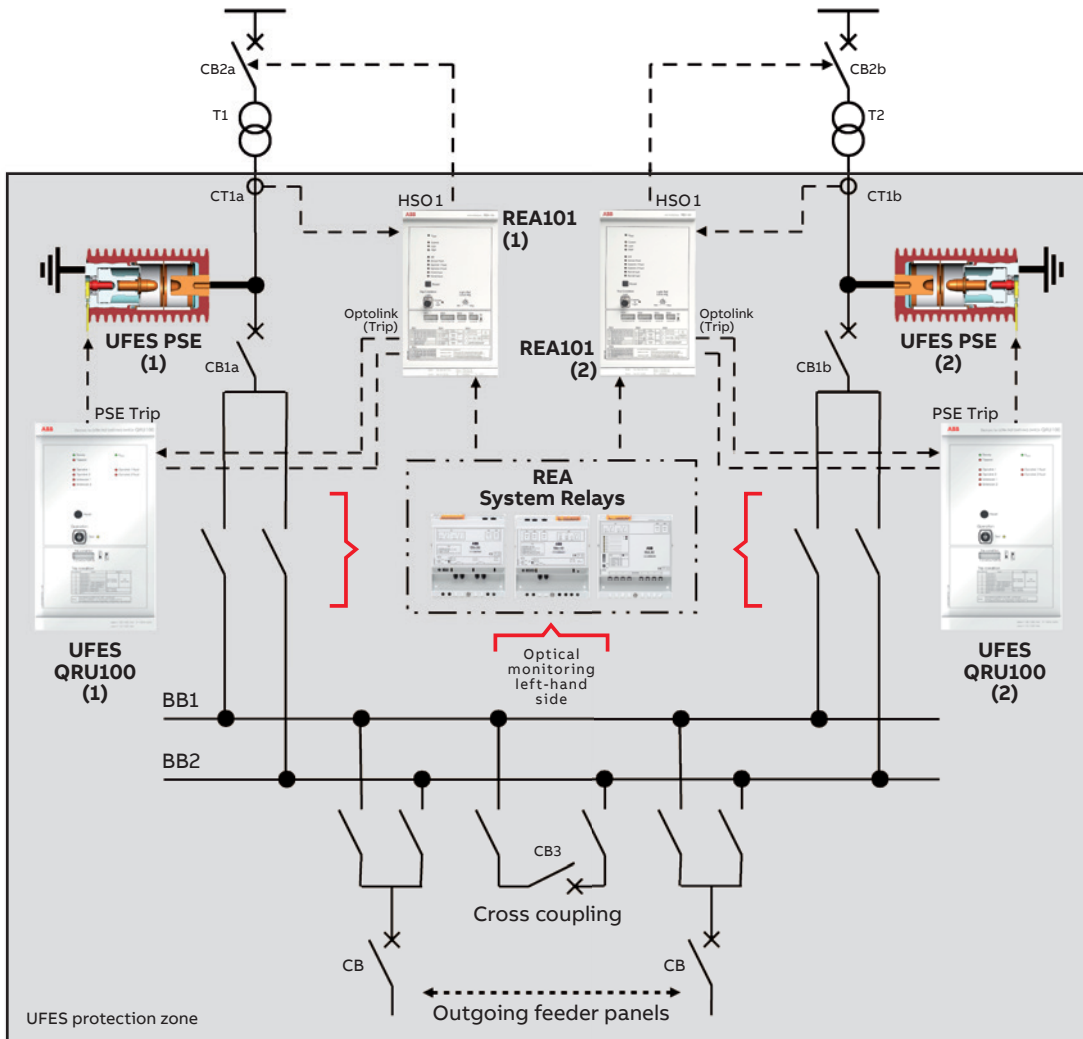

Fig. 4.6-1

The example here shows a switchgear system with an open design. The switchgear system has two incoming circuit-breakers, which can be connected via disconnector to either BB1 or BB2. Same applies to the circuit-breakers of the outgoing feeders. Furthermore the busbar sections of BB1 and BB2 can be operated in parallel via transverse coupling.

The open design of the switchgear and therewith, the typically associated local mixing of the individual systems in the busbar or disconnectors area, does not allow a clear optical triage of the faulty system. To trip only the necessary Ultra-Fast Earthing Switch(es) for the extinguishing of the arc, a protection concept with current selectivity has to be applied.

Current selectivity

One Ultra-Fast Earthing Switch is installed in each terminal area of the incoming feeder. The dedicated external detection units of the individual Ultra-Fast Earthing Switches measure the current at the particular incomer only. Light, as the second criteria, will be detected for all areas in whole and provided to all protection systems as tripping criteria.

In the event of an arc fault in the UFES protection zone, only the Ultra-Fast Earthing Switch of the incomer, which is feeding the fault, will operate.

5 General notes on installation

5.1 Primary switching elements (PSE)

The possible immediate short circuit earthing zone and therewith the UFES protection zone within the switchgear system to be monitored is defined by the location where the PSE are installed. The immediate protection zone within the switchgear system in principle is given upwards (opposite feeding direction) from the point of installation of the PSE to the downstream side of the next separation point (circuit-breaker, load break switch, etc.). The downward areas are automatically included and so protection is ensured down to the outgoing terminals of the outgoing feeder circuit-breakers. Special configurations reflecting this definition, in which the standard protection concept is modified, are not mentioned here and should be considered as individual cases where required. The choice of the ideal installation location for each specific application depends on the design of the respective switchgear system and the intended protection concept. It is in principle advisable to locate the PSE in the area of the busbars or cable terminations, as close as possible to the incoming feeder of the defined protection zone.

5.2 UFES electronics (Type QRU100 or type QRU1)

The UFES electronics can be installed at any point in a low voltage compartment of the switchgear system, or also outside the switchgear system. It should however be remembered that the maximum cable length between the UFES electronics and the PSE must not exceed 10 m.

The standard method is door mounting. If required, however, the UFES electronics can also be installed in the switchgear or outside on a wall using a surface mounting set which is available as an optional extra.

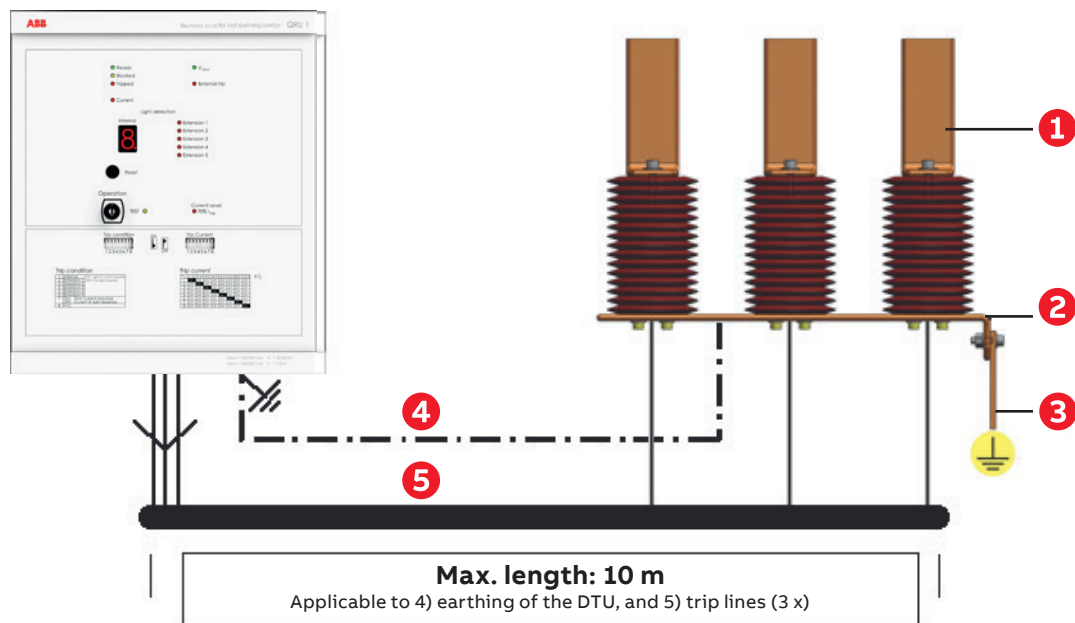

Fig. 5.2-1 System configuration

- 1 Customized, live bar system
- 2 PSE earthing bar
Material: Copper
Width: Min. 80 mm (depending on design)
Cross-section: Min. 400 mm²; 800 mm² (80x10 copper bar) recommended
- 3 Earthing bar system (connection to station earth)
Material: Copper
Cross-section: Min. 240 mm²; 30x8 copper bar (240 mm²) recommended
- 4 Earthing of the DTU / TU
Cu cable (min. 2.5 mm² flexible or 4.0 mm² rigid)
- 5 Trip lines (DTU / TU → PSE)
Made-up, screened Cu cable with special system plug connectors, 2-core, twisted, included in the UFES kit supply.

5.3 Light detectors for connection to the QRU1

Detector cables are available in standard lengths (see ordering data). They may not be shortened or spliced. Sharp kinks or pinching during installation of the cables are to be avoided. The plastic fibre consists of polymethyl methacrylate (PMMA) with a PVC jacket. Each detector consists of an optical cable and a lens, which are tested and calibrated together at the works so as to achieve identical sensitivity independently of the cable length. The lens admits light from all directions with the exception of a small screened-off area behind the detector (cf. distribution diagram).

Practical trials have shown that the light from an arc reflected between metallic surfaces is normally sufficient for a trip. This has to be tested in each particular case.



Fig. 5.3-1 Lens sensor

5.3.1 Detector positioning

When positioning the sensors, it is to be ensured that all the switchgear system compartments or areas to be monitored in accordance with the selected protection concept are covered. Every panel should be monitored if possible.

Detectors shall not be positioned in such a way that they react to the normal switching arc of a circuit-breaker. The sensor can detect arcing at a distance of 3 metres (see illustration 5.3-2). In order to increase the level of safety even further, the sensors can be installed at distances of 1.5 metres, thus creating redundancies.

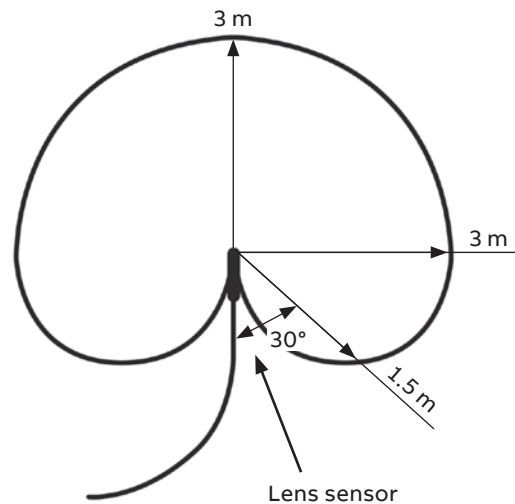

Fig. 5.3-2 Detection range of a lens sensor

6 Technical data

6.1 Primary switching element

6.1.1 Electrical properties

		Type											
		U1-14-063	U1-14-100	U1-175-25	U1-175-40	U1-175-50	U1-175-63	U1-270-25	U1-270-40	U1-360-25	U1-360-40	U2-405-25 ¹⁾	U2-405-40 ¹⁾
Rated voltage (rms)	kV	1.4	1.4	17.5	17.5	17.5	17.5	27	27	36	36	40.5	40.5
Rated short-time withstand current (rms)	kA	63	100	25	40	50	63	25	40	25	40	25	40
Rated short duration power-frequency withstand voltage (rms)	kV	5	5	42	42	42	42	60	60	70	70	95	95
Rated lightning impulse withstand voltage (peak)	kV	12	12	95	95	95	95	150	150	170	170	200	200
Rated frequency	Hz	50/60	50/60	50/60	50/60	50/60	50/60	50/60	50/60	50/60	50/60	50/60	50/60
Rated peak withstand current	kA	140	220	65	104	130	165	65	104	65	104	65	104
Rated short-circuit duration	s	1	0.5	3	3	3	2	3	3	3	3	3	3
Rated short-circuit making current	kA	140	220	65	104	130	165	65	104	65	104	65	104

¹⁾ On request

6.1.2 Mechanical properties (all types)

Type		U1	U2
Dimensions (diameter x height)	mm	137 x 210	137 x 301
Weight	kg	max. 5.5	max. 8.5
Operating time	ms	< 1.5	
Contact bounce time	ms	0	

6.1.3 Service life expectation

At rated voltage and under the ambient conditions stated

Number of making operations		1
Mechanical	Years	up to 30
Micro gas generator (SMGG)	Years	up to 15

6.1.4 Ambient conditions

Operating temperature range	-5 to +70 °C ²⁾
Transport temperature range	-25 to +70 °C (max. 48 hours)
Storage temperature range	-5 to +40 °C
Ambient humidity (storage)	max. 65 %, non-condensing
Site altitude	1000 m above NN

²⁾ Different conditions on request

6.2 Electronic tripping unit type QRU100

6.2.1 Mechanical properties

Degree of protection, front (flush mounted)	IP 4X
Degree of protection (enclosure as a whole)	IP 2X
Weight	~ 4.5 kg

6.2.2 Auxiliary power supply

Rated voltage	120 V & 230 V AC (50/60 Hz) 110 V & 220 V DC
Tolerance range of rated voltage	85 % - 110 % U_f (AC) 70 % - 120 % U_f (DC)
Rated insulation voltage	2 kV
Power consumption	< 25 VA

6.2.3 Extension inputs for external detection units

Optolink	2 x
Extension (HSI)	2 x

6.2.4 Signal / control contacts

Signals	3 x Tripped 1 x U_{int} 1 x Ready 1 x Test
Type	Changeover, floating
Rated voltage	250 V (AC or DC)
Rated current	5 A
Rated making current (0.5 s)	10 A
Rated making current (3 s)	8 A
Breaking capacity (L/R < 40 ms), 48 V DC	2 A
Breaking capacity (L/R < 40 ms), 110 V DC	0.4 A
Breaking capacity (L/R < 40 ms), 220 V DC	0.25 A

6.2.5 "Extension" inputs (High-speed input – HSI)

Output voltage	~ 22 V DC
Output current	~ 10 mA DC

6.2.6 "Optolink" – Signal transfer fiber to REA system

Max. length of plastic fiber	40 m
Max. length of glass fiber	2,000 m
Operating temperature range	-35 to +80 °C
Min. permissible bending radius	50 mm

6.2.7 Ambient conditions

Operating temperature range	-25 to +55 °C
Transport and storage temperature range	-25 to +70 °C
Ambient humidity	max. 65 %, non-condensing
Site altitude	2000 m above NN

6.2.8 Reaction times

Start time of electronics	1 s
Input signal to trip signal (Optolink)	~ 400 μ s
Input signal to trip signal (Extension)	~ 400 μ s

6.3 Electronic detection and tripping unit type QRU1

6.3.1 Mechanical properties

Degree of protection, front (flush mounted)	IP 4X
Degree of protection (enclosure as a whole)	IP 2X
Weight	~5.5 kg

6.3.2 Auxiliary power supply

Rated voltage	120 V & 230 V AC (50/60 Hz) 110 V & 220 V DC
Tolerance range of rated voltage	85 % - 110 % U_r (AC) 70 % - 120 % U_r (DC)
Rated insulation voltage	2 kV
Power consumption	< 25 VA

6.3.3 Detection and control inputs (overview)

Optical (light detection)	9 x
Current transformer	3 x
External tripping	1 x
External blocking	1 x
External detection units	5 x

6.3.4 Current transformer inputs

Rated input current I_r	1 A and 5 A
Rated frequency	50 / 60 Hz
Continuous load current	4 x I_r
Rated short-time current, 1 s	100 x I_r
Rated peak withstand current	250 x I_r
Burden	< 0.5 VA

6.3.5 Control inputs: Ext. Trip / Ext. Blocked

Rated voltage AC	24 V to 250 V
Rated voltage DC	24 V to 250 V
Reaction time "Ext. Blocked"	< 30 ms
Reaction time "Ext. Trip"	< 15 ms

6.3.6 Signal/control contacts

Signals	3 x Tripped 1 x Blocked 1 x Ready 1 x Test
Type	Changeover, floating
Rated voltage	250 V (AC or DC)
Rated current	5 A
Rated making current (0.5 s)	10 A
Rated making current (3 s)	8 A
Breaking capacity (L/R < 40 ms), 48 V DC	2 A
Breaking capacity (L/R < 40 ms), 110 V DC	0.4 A
Breaking capacity (L/R < 40 ms), 220 V DC	0.25 A

6.3.7 Extension inputs

Output voltage	approx. 12 V DC
Output current	approx. 5 mA DC

6.3.8 Optical sensors for the QRU1

Type	Lens sensor
Max. length of optical fibre cable	30 m ¹⁾
Min. permissible bending radius	50 mm
Ambient temperature	-25 to +70 °C
Ambient temperature (short time)	-25 to +85 °C
Ambient light intensity without tripping	3000 lux

¹⁾ Greater lengths on request

6.3.9 Setting range for current detection

Current settings x I_r	1.5 / 2.0 / 3.0 / 4.0 / 5.0 / 6.0 / 8.0 / 10.0
Error in operating value 1.5 - 6.0 x I_r	+/- 5 % of setting
Error in operating value 8.0 - 10.0 x I_r	+/- 12 % of setting

6.3.10 Ambient conditions

Operating temperature range	-25 to +55 °C
Transport and storage temperature range	-25 to +70 °C
Ambient humidity	max. 65 %, non-condensing
Site altitude	2000 m above NN

6.3.11 Reaction times

Start time of electronics	1 s
Input signal to trip signal (extension)	~ 250 μ s

7 Dimensions

7.1 Electronic tripping unit type QRU100

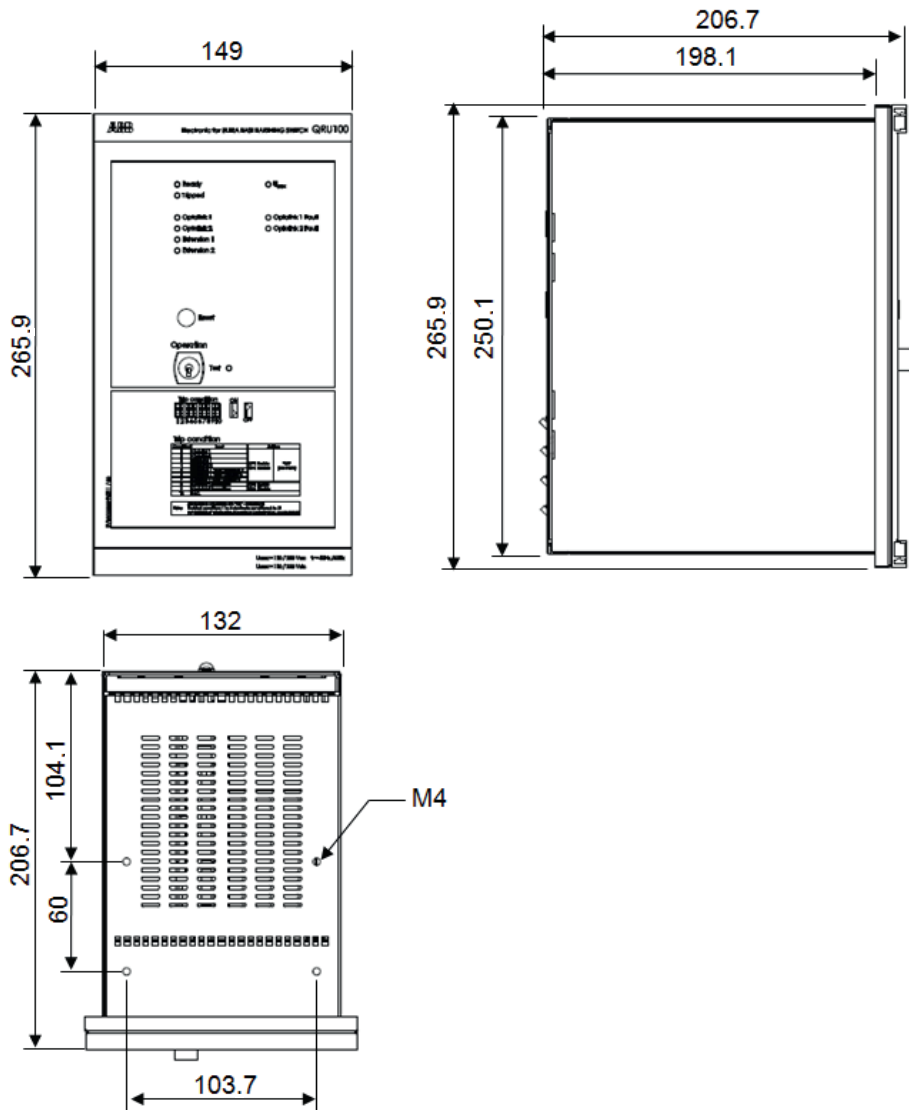

7.2 Primary switching element type U1

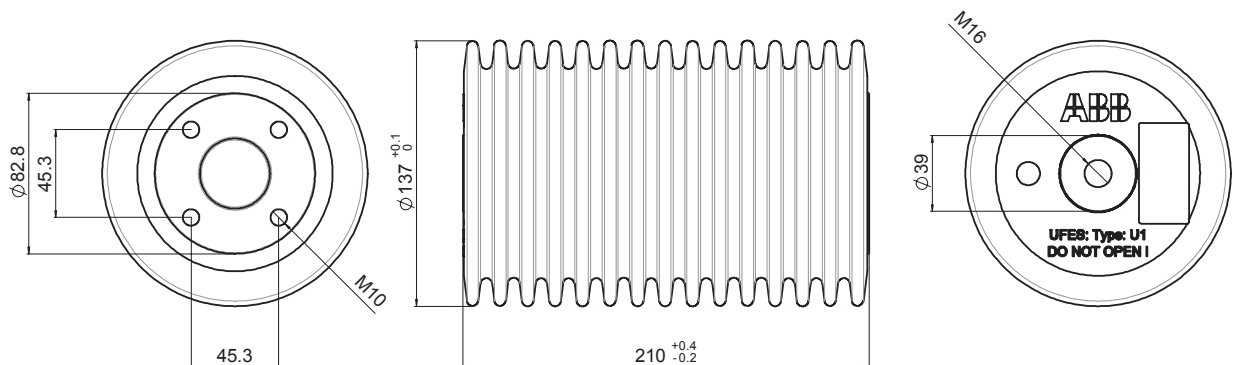

7.3 Electronic detection and tripping unit type QRU1

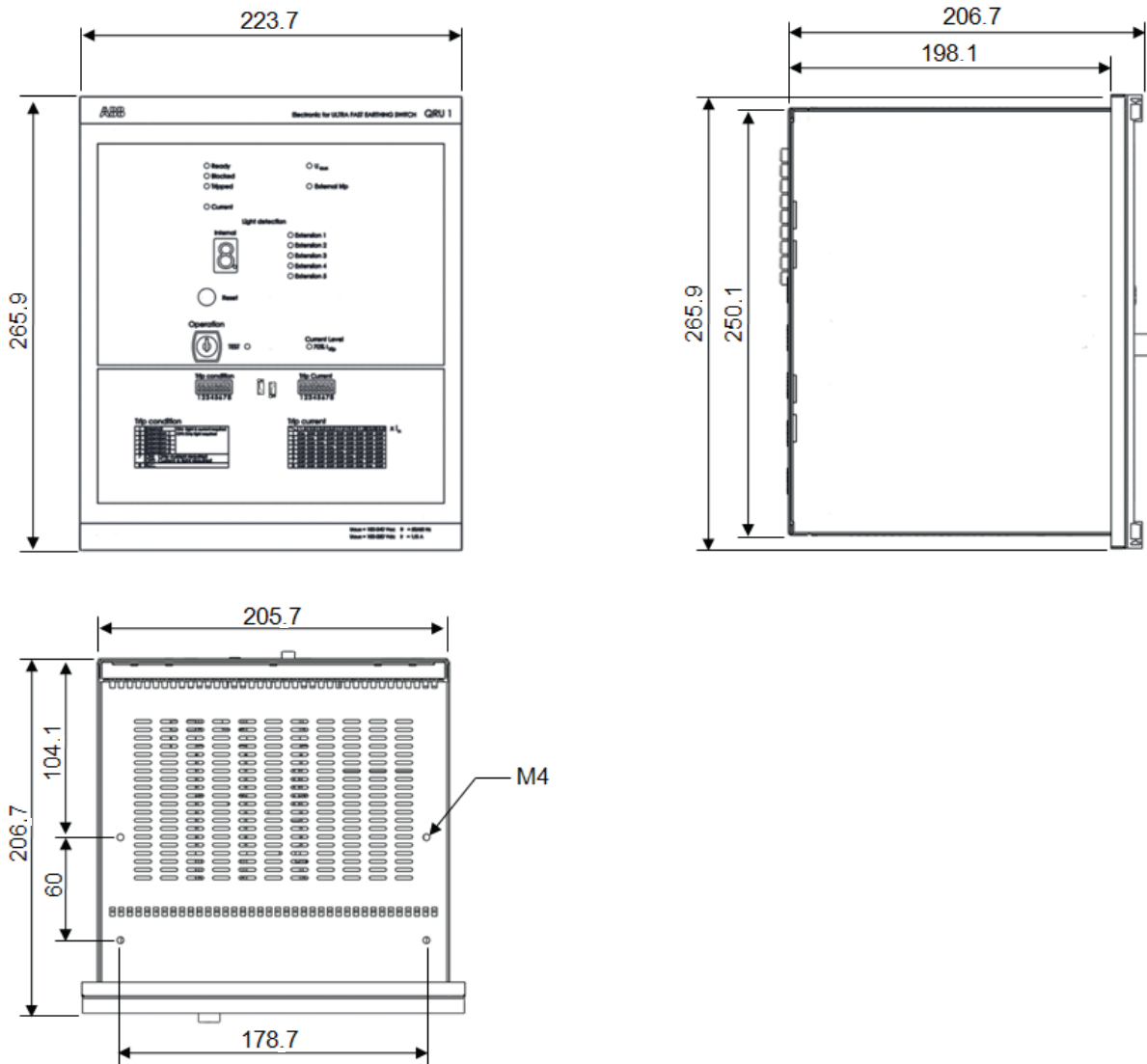

7.4 Primary switching element type U2

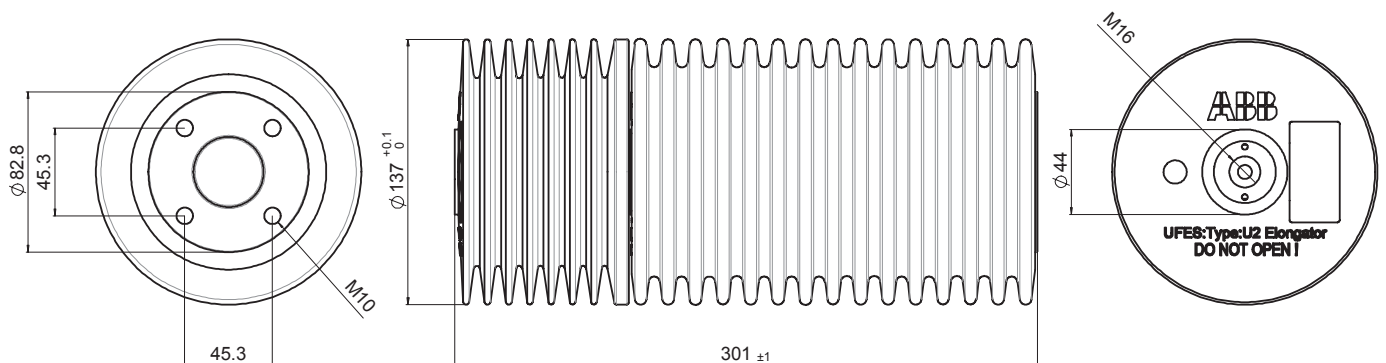

8 Circuit diagrams

8.1 Block diagram of Ultra-Fast Earthing Switch

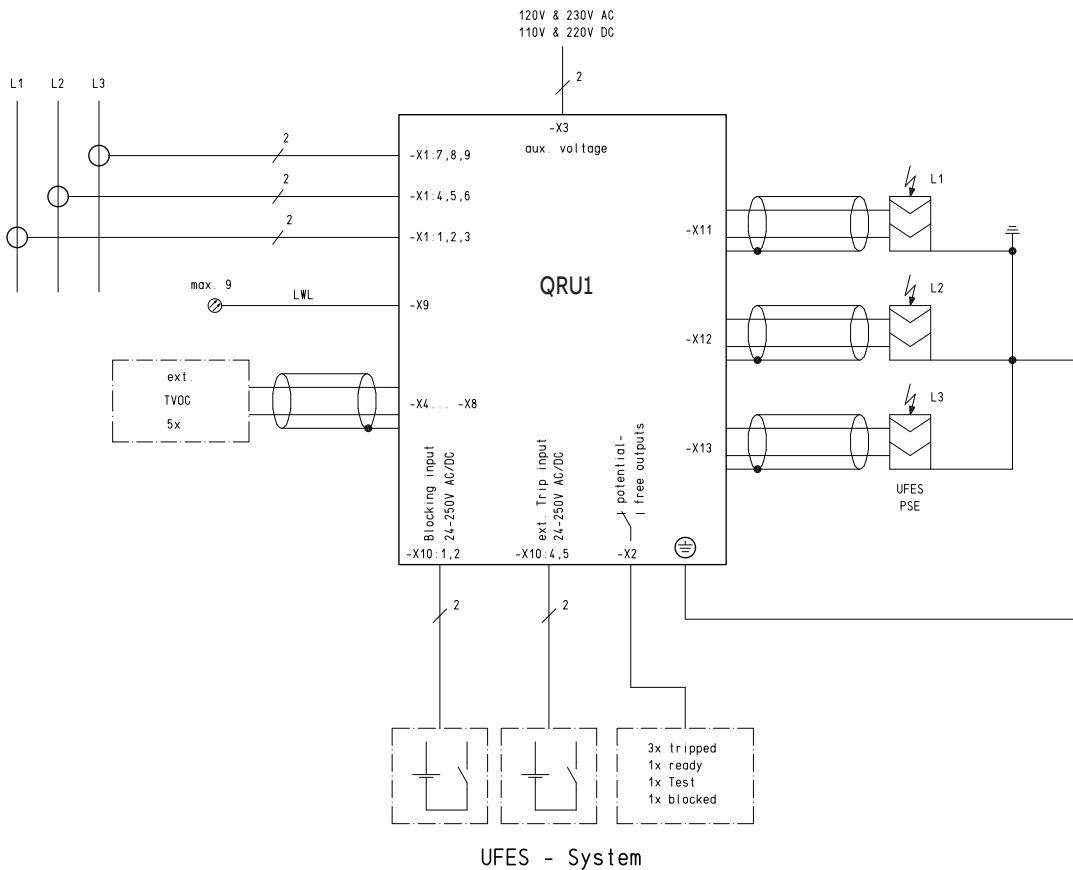
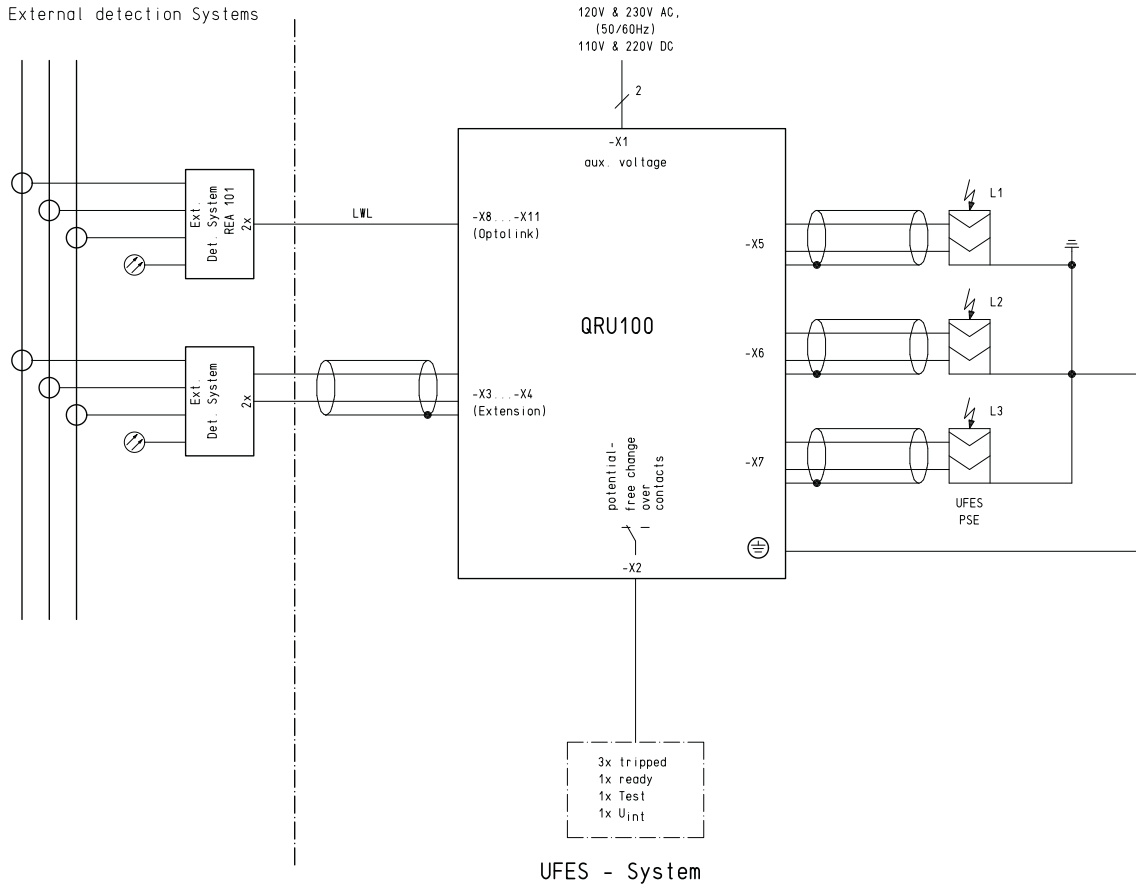

8.2 Terminal and single line diagram of the electronic tripping unit, type QRU100

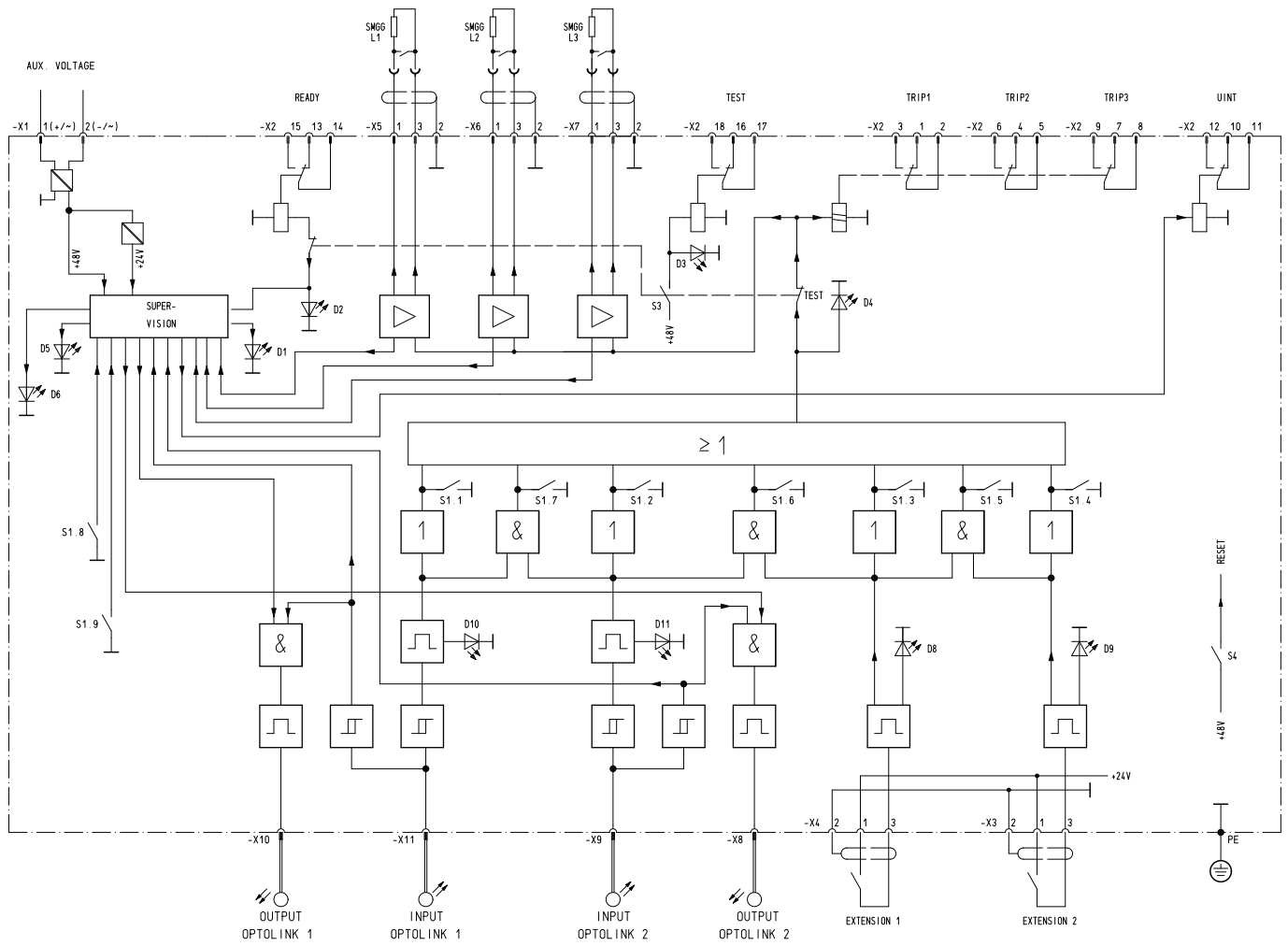
**Legend to QRU100-operator controls and displays**

In circuit diagram	On front panel	Colour
D1	U_{aux}	green / yellow
D2	Ready	green
D3	Test	yellow
D4	Tripped	red
D5	Optolink Fault 1	red
D6	Optolink Fault 2	red
D8	Extension 1	red
D9	Extension 2	red
D10	Optolink 1	red
D11	Optolink 2	red
S1	Trip Condition	
S3	Test	
S4	Reset	

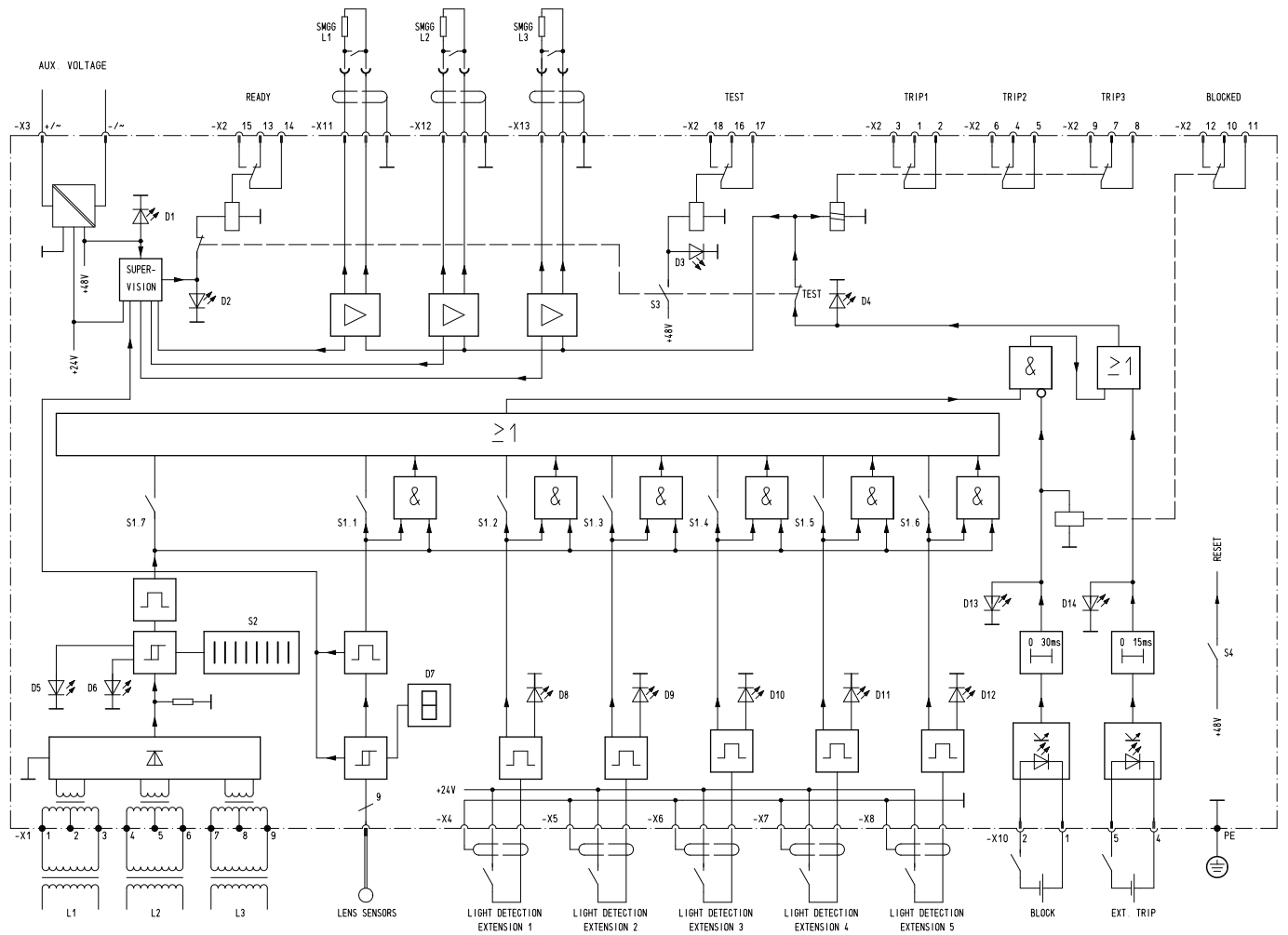

8.3 Terminal and single line diagram of the electronic detection and tripping unit, type QRU1



Legend to QRU1 operator controls and displays

In circuit diagram	On front panel	Colour
D1	U_{aux}	green
D2	Ready	green
D3	Test	yellow
D4	Tripped	red
D5	$70\% I_{trip}$	yellow
D6	Current trip	red
D7	Internal	red
D8	Extension 1	red
D9	Extension 2	red
D10	Extension 3	red
D11	Extension 4	red
D12	Extension 5	red
D13	External trip	red
D14	Blocked	yellow
S1	Trip Condition	
S2	Trip Current	
S3	Test	
S4	Reset	

9 Ordering details

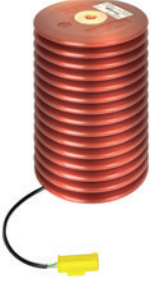
	Item	Description	Type design.	Part number
	1a	UFES Kit 100		
		consisting of:		
		• 1 pc. Electronic Tripping Unit (TU), type QRU100		1VB9001025...
		• 3 pcs. Primary Switching Elements (PSE)		
		• 3 pcs. Trip lines. UFES electronics → PSE, 10 m (without picture)		
		• 1 pc. Door mounting kit (without picture)		
			POF²⁾	GOF¹⁾²⁾
	1.1a	UFES Kit 100 - 17.5 kV / 25 kA	Kit100-175-25	...R1133 ...R1143
	1.2a	UFES Kit 100 - 17.5 kV / 40 kA	Kit100-175-40	...R1233 ...R1243
	1.3a	UFES Kit 100 - 17.5 kV / 50 kA	Kit100-175-50	...R1333 ...R1343
	1.4a	UFES Kit 100 - 17.5 kV / 63 kA	Kit100-175-63	...R1433 ...R1443
	1.5a	UFES Kit 100 - 27 kV / 25 kA	Kit100-270-25	...R2133 ...R2143
	1.6a	UFES Kit 100 - 27 kV / 40 kA	Kit100-270-40	...R2233 ...R2243
	1.7a	UFES Kit 100 - 36 kV / 25 kA	Kit100-360-25	...R3133 ...R3143
	1.8a	UFES Kit 100 - 36 kV / 40 kA	Kit100-360-40	...R3233 ...R3243
	1.9a	UFES Kit 100 - 40.5 kV / 25 kA ¹⁾	Kit100-405-25	...R4133 ...R4143
	1.10a	UFES Kit 100 - 40.5 kV / 40 kA ¹⁾	Kit100-405-40	...R4233 ...R4243
	1.11a	UFES Kit 100 - 1.4 kV / 63 kA	Kit100-14-63	...R0433 ...R0443
Item 1.1a - 1.8a. 1.11a. 1.12a	1.12a	UFES Kit 100 - 1.4 kV / 100 kA	Kit100-14-100	...R0533 ...R0543
	1b	UFES Kit 1		
		consisting of:		
		• 1 pc. Electronic Detection and Tripping Unit (DTU), type QRU1		
		• 3 pcs. Primary Switching Elements (PSE)		
		• 3 pcs. Trip lines. UFES electronics → PSE, 10 m (without picture)		
		• 1 pc. Door mounting kit (without picture)		
	1.1b	UFES Kit 1 - 17.5 kV / 25 kA	Kit1-175-25	1VB9001014R1103
	1.2b	UFES Kit 1 - 17.5 kV / 40 kA	Kit1-175-40	1VB9001014R1203
	1.3b	UFES Kit 1 - 17.5 kV / 50 kA	Kit1-175-50	1VB9001014R1303
	1.4b	UFES Kit 1 - 17.5 kV / 63 kA	Kit1-175-63	1VB9001014R1403
	1.5b	UFES Kit 1 - 27 kV / 25 kA	Kit1-270-25	1VB9001014R2103
	1.6b	UFES Kit 1 - 27 kV / 40 kA	Kit1-270-40	1VB9001014R2203
	1.7b	UFES Kit 1 - 36 kV / 25 kA	Kit1-360-25	1VB9001014R3103
	1.8b	UFES Kit 1 - 36 kV / 40 kA	Kit1-360-40	1VB9001014R3203
	1.9b	UFES Kit 1 - 40.5 kV / 25 kA ¹⁾	Kit1-405-25	1VB9001014R4103
	1.10b	UFES Kit 1 - 40.5 kV / 40 kA ¹⁾	Kit1-405-40	1VB9001014R4203
	1.11b	UFES Kit 1 - 1.4 kV / 63 kA	Kit1-14-63	1VB9001014R0403
Item 1.1b - 1.8b. 1.11b. 1.12b	1.12b	UFES Kit 1 - 1.4 kV / 100 kA	Kit1-14-100	1VB9001014R0503
	2	Primary switching element		
	2.1	Primary switching element - 17.5 kV / 25 kA	U1-175-25	1VB9001016R1110
	2.2	Primary switching element - 17.5 kV / 40 kA	U1-175-40	1VB9001016R1120
	2.3	Primary switching element - 17.5 kV / 50 kA	U1-175-50	1VB9001016R1130
	2.4	Primary switching element - 17.5 kV / 63 kA	U1-175-63	1VB9001016R1140
	2.5	Primary switching element - 27 kV / 25 kA	U1-270-25	1VB9001016R1210
	2.6	Primary switching element - 27 kV / 40 kA	U1-270-40	1VB9001016R1220
	2.7	Primary switching element - 36 kV / 25 kA	U1-360-25	1VB9001016R1310
	2.8	Primary switching element - 36 kV / 40 kA	U1-360-40	1VB9001016R1320
	2.9	Primary switching element - 40.5 kV / 25 kA ¹⁾	U2-405-25	1VB9001016R2410
	2.10	Primary switching element - 40.5 kV / 40 kA ¹⁾	U2-405-40	1VB9001016R2420
	2.11	Primary switching element - 1.4 kV / 63 kA	U1-14-63	1VB9001016R1040
	Item 2.1 - 2.8. 2.11. 2.12	2.12	Primary switching element - 1.4 kV / 100 kA	U1-14-100

¹⁾ On request²⁾ Design of Optolink interface on TU:- POF: Plastic optical fiber
- GOF: Glass optical fiber

Item	Description	Type design.	Part number
3	Lens sensors for UFES electronic detection and tripping unit (DTU) type QRU1		
3.1	Cable length 1 m	TVOC-1-DP1	1SFA663 003 R1010
3.2	Cable length 2 m	TVOC-1-DP2	1SFA663 003 R1020
3.3	Cable length 4 m	TVOC-1-DP4	1SFA663 003 R1040
3.4	Cable length 6 m	TVOC-1-DP6	1SFA663 003 R1060
3.5	Cable length 8 m	TVOC-1-DP8	1SFA663 003 R1080
3.6	Cable length 10 m	TVOC-1-DP10	1SFA663 003 R1100
3.7	Cable length 15 m	TVOC-1-DP15	1SFA663 003 R1150
3.8	Cable length 20 m	TVOC-1-DP20	1SFA663 003 R1200
3.9	Cable length 25 m	TVOC-1-DP25	1SFA663 003 R1250
3.10	Cable length 30 m	TVOC-1-DP30	1SFA663 003 R1300



Item 3.1 - 3.10

Item	Description	Type design.	Part number
4	Accessories		
4.1.1	UFES electronic tripping unit (TU), POF ²⁾	QRU100	1VB9001015R0530
4.1.2	UFES electronic tripping unit (TU), GOF ²⁾	QRU100	1VB9001015R0540
4.2	UFES Electronic detection- and tripping unit (DTU)	QRU1	1VB9001015R1000
4.3	Trip cable UFES electronics → PSE, 10 m		1VB9000978R0101
4.4.1	Connecting cable, UFES electronics → REA / TVOC, 10 m		1VB9000979R0101
4.4.2	Connecting cable, UFES electronics → REA / TVOC, 2 m		1VB9000979R0021
4.5	Wall installation kit for UFES electronics		1VB9001672R0101
4.6	Door installation kit for UFES electronics		1VB9001024R0101
4.7	Test plug		1VB9001023R0101



Item 4.7

Item	Description	Type design.	Part number
5	TVOC-2⁴⁾		
5.1	Arc monitor (10 optical inputs) including HMI and accessories for door installation	TVOC-2-240	1SFA664001R1001
5.2	Extension (Plug-in unit) 10 optical inputs	TVOC-2-E1	1SFA664002R1001
5.3	Extension (Plug-in unit) 10 optical inputs for 60 m detector cable ¹⁾	TVOC-2-E3	1SFA664002R3001



Item 5.1

Item	Description	Type design.	Part number
5.4	Lens sensors for TVOC-2⁴⁾		
5.4.1	Cable length 1m	TVOC-2-DP1	1SFA664003R1010
5.4.2	Cable length 2m	TVOC-2-DP2	1SFA664006R1020
5.4.3	Cable length 4m	TVOC-2-DP4	1SFA664003R1040
5.4.4	Cable length 6 m	TVOC-2-DP6	1SFA664003R1060
5.4.5	Cable length 8 m	TVOC-2-DP8	1SFA664003R1080
5.4.6	Cable length 10 m	TVOC-2-DP10	1SFA664003R1100
5.4.7	Cable length 15 m	TVOC-2-DP15	1SFA664003R1150
5.4.8	Cable length 20 m	TVOC-2-DP20	1SFA664003R1200
5.4.9	Cable length 25 m	TVOC-2-DP25	1SFA664003R1250
5.4.10	Cable length 30 m	TVOC-2-DP30	1SFA664003R1300
5.4.11	Cable length 60 m ¹⁾	TVOC-2-DP60	1SFA664003R3600



Item 5.4.1 - 5.4.10

¹⁾ On request²⁾ Design of Optolink interface on TU:
- POF: Plastic optical fiber
- GOF: Glass optical fiber³⁾ Extract of REA catalogue. Information to other system components can be found in the dedicated product catalogue.⁴⁾ Extract of TVOC-2 catalogue. Information to other system components can be found in the dedicated product catalogue.

Item	Description	Type design.	Part number
6	Optolink³⁾		
6.1	Connecting cable POF, AE → REA101, 2 m		1VB9001270R1020
6.2	Connecting cable POF, AE → REA101, 5 m		1VB9001270R1050
6.3	Connecting cable POF, AE → REA101, 10 m		1VB9001270R1100
6.4	Connecting cable POF, AE → REA101, 20 m		1VB9001270R1200
6.5	Connecting cable POF, AE → REA101, 40 m		1VB9001270R1400
7	UFES Truck^{1) 5)}		
	Package consisting of:		
	- 1 pc. Draw-out unit with connecting cable and 58-pole plug		
	- 3 pcs. Primary Switching Elements (PSE)		
	- 1 pc. Blocking magnet (Truck blocking)		
	- 2 pcs. Auxiliary switch (Position indication)		
	- 3 pcs. Trip lines UFES electronics → UFES Truck, 8 m		
	Not included in package:		
	- UFES electronics		
	- Panel side 58-pole socket		
7.x	UFES Truck, various ratings		
	- Rated voltage: 17.5 ... 24 kV	UT1	
	- Rated short-time withstand current: 25 ... 50 kA		

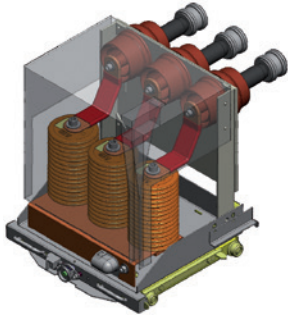

¹⁾ On request

²⁾ Design of Optolink interface on TU:
 - POF: Plastic optical fiber
 - GOF: Glass optical fiber

³⁾ Extract of REA catalogue. Information to other system components can be found in the dedicated product catalogue.

⁴⁾ Extract of TVOC-2 catalogue. Information to other system components can be found in the dedicated product catalogue.

⁵⁾ Available for order only after full technical classification.

A 1 Guideline for the determination of the current threshold

The following section describes the recommended method for the determination of the threshold value, which has to be set on a current detection unit of the UFES arc protection system. The current detection unit can be either part of a UFES electronic detection and tripping unit type QRU1 or part of another arc protection relay like e.g. the ABB REA101 relay.

For the determination of the current threshold, the minimum initial symmetrical 3-phase short-circuit current $I_k''\text{min}$ flowing through the used current transformers to the fault location in the event of a fault, needs to be identified. The applicable network conditions for this approach are described in the following. A detailed description for the calculation of short-circuit currents can be found additionally in the IEC 60909 standard.

Applicable network conditions

- voltage factor c_{min} shall be applied;
- system configuration which lead to a minimum value of short-circuit current at the short-circuit location shall be considered;
- minimum contribution from power stations and network feeders which lead to a minimum value of short-circuit current at the short-circuit location shall be considered;
- contributions from motors shall be neglected;
- line resistances shall be considered at a higher temperature.

Reduction factors

In order to achieve a threshold value with a sufficient sensitivity, this calculated minimum initial symmetrical short-circuit current $I_k''\text{min}$ should be multiplied with further reduction factors. These factors, taking into account possible arc fault conditions, are based on the following assumptions.

1. a In networks with high impedance earthed neutral – typically medium voltage networks – a high-energy arc fault starts with high probability as a two-phase fault. For such networks, $I_k''\text{min}$ should be multiplied by the factor 0.87.
1. b In networks with solidly earthed neutral – typically low voltage networks – a high-energy arc fault could already start as a single-phase fault. For such networks, $I_k''\text{min}$ should be multiplied by the factor 0.6.
2. The arc voltage/arc impedance reduces the value of the fault current. Therefore $I_k''\text{min}$ should be multiplied by the factor 0.5.
3. The current transformers (protection core) included in an entire current detection loop can have inaccuracies of up to 14 %. Therefore $I_k''\text{min}$ should be multiplied by the factor 0.86.

Calculation

Summarizing the above, the following calculation of the current threshold value is recommended:

For networks with high impedance earthed neutral:

$$I_{\text{trip}} = I_k''\text{min} \times 0.87 \times 0.5 \times 0.86 = I_k''\text{min} \times 0.37$$

For networks with solidly earthed neutral:

$$I_{\text{trip}} = I_k''\text{min} \times 0.6 \times 0.5 \times 0.86 = I_k''\text{min} \times 0.26$$

$$I_k''\text{min} = \text{Minimum initial symmetrical short-circuit current}$$

$$I_{\text{trip}} = \text{Calculated current threshold}$$

In case the calculated current threshold is below the rated normal current value, the current threshold should be chosen to 1.5 times of the rated normal current or other current sensing set-ups like differential protection measurements should be applied.

Finally, it must be ensured that the used current transformers can transmit the current up to the chosen current threshold without any discernible saturation effects.

For your notes

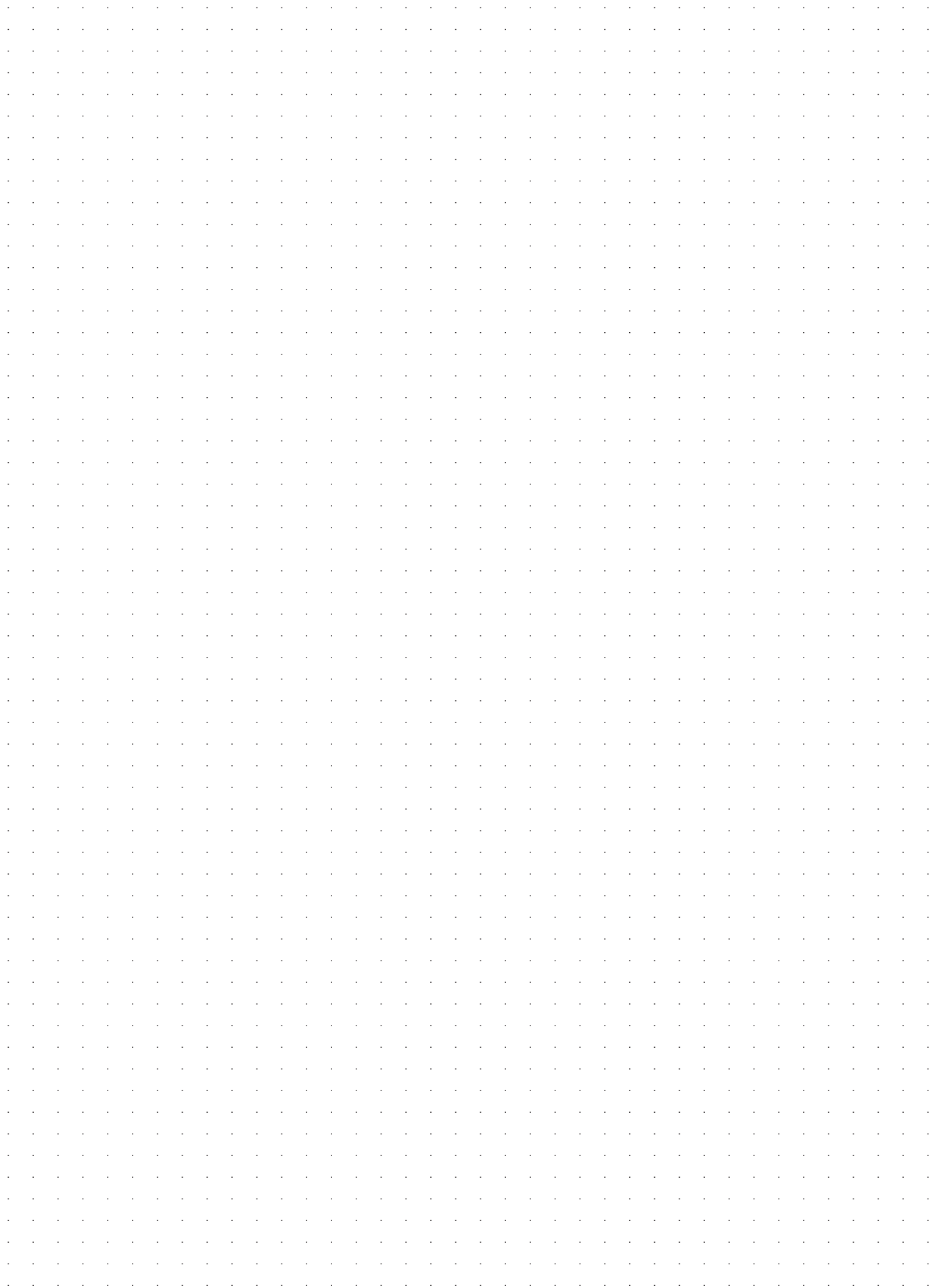

For your notes

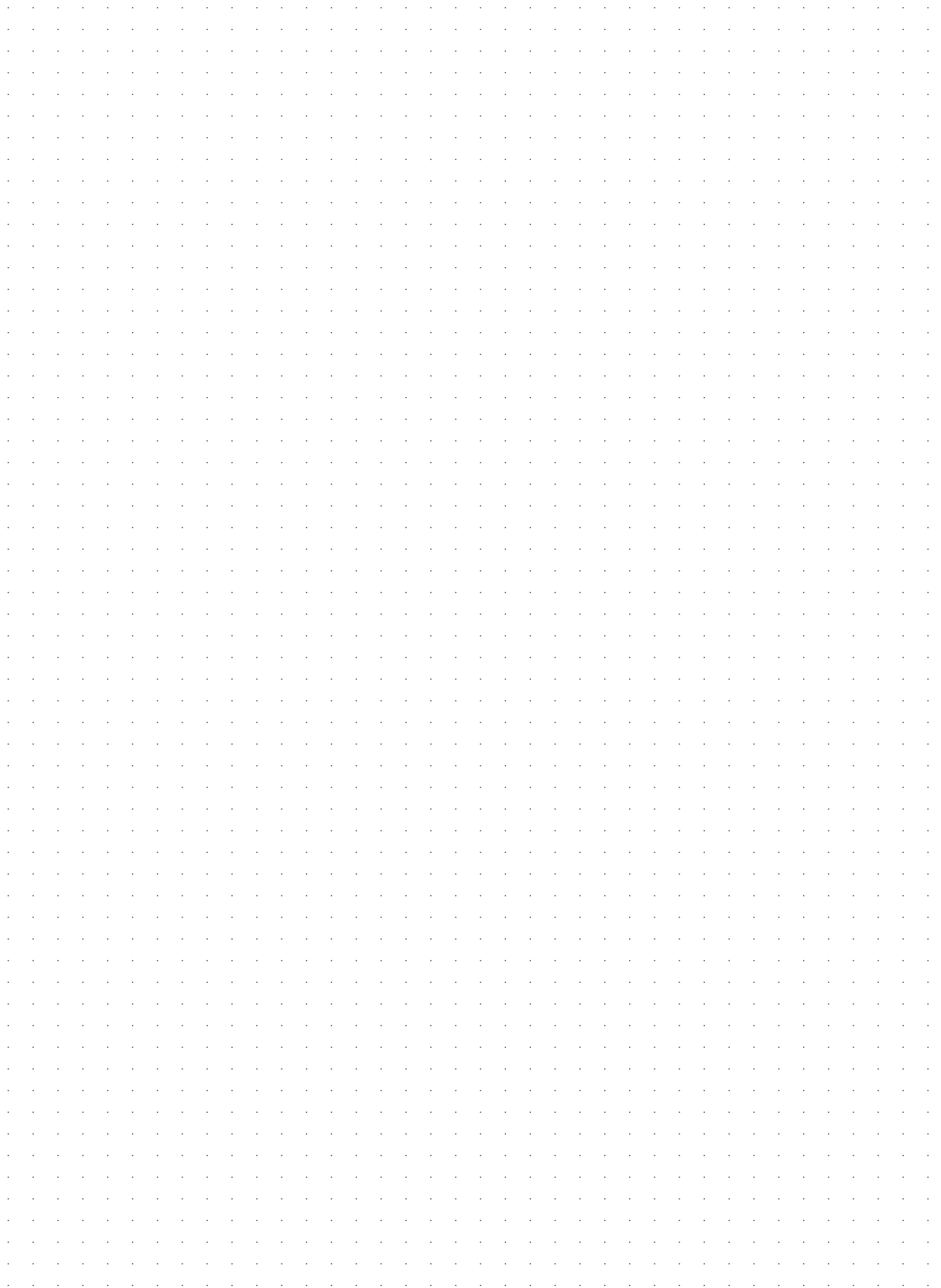



—

ABB AG

Oberhausener Strasse 33

40472 Ratingen

Germany

Telephone: +49 2102 12-0

Fax: +49 2102 12-17 77

abb.com/mediumvoltage

Additional information

We reserve the right to make technical changes or modify the contents of this document without prior notice. With regard to purchase orders, the agreed particulars shall prevail. ABB AG does not accept any responsibility whatsoever for potential errors or possible lack of information in this document.

We reserve all rights in this document and in the subject matter and illustrations contained therein. Any reproduction, disclosure to third parties or utilization of its contents – in whole or in parts – is forbidden without prior written consent of ABB AG.

© Copyright 2018 ABB. All rights reserved.
Specifications subject to change without notice.