

# IRB 140

## Industrial Robot

### MAIN APPLICATIONS

- Arc welding
- Assembly
- Cleaning/Spraying
- Machine tending
- Material handling
- Packing
- Deburring



### Small, Powerful and Fast

Compact, powerful IRB 140 industrial robot. Six axis multipurpose robot comprising IRB 140 manipulator and S4Cplus industrial robot controller. Handles payload of 5kg, with long reach (810 mm) of axis 5, optional floor, wall and suspended mounting. Available as Standard, Foundry and Clean Room versions, all mechanical arms completely IP67 protected, making IRB 140 easy to integrate in and suitable for a variety of applications. Uniquely extended radius of working area due to bend-back mechanism of upper arm, axis 1 rotation of 360 degrees and flexible mounting capabilities.

The compact, robust design with integrated cabling adds to overall flexibility. The Collision Detection option with full path retraction makes robot reliable and safe.

Using IRB 140T, cycle-times are considerably reduced where axis 1 and 2 predominantly are used.

Reduction between 15-20 % are possible using pure axis 1 and 2 movements.

This faster version is well suited for packing applications and guided operations together with PickMaster.

IRB Foundry Plus versions are suitable for operating in extreme foundry environments. In addition to the IP67 protection, excellent surface treatment makes the robot high pressure steam washable. The white-finish Clean-Room versions meets Clean-Room 10 regulations, making it especially suited for environments with stringent cleanliness standards.

The S4Cplus controller has the electronics for controlling the robot manipulator, external axes and peripheral equipment. S4Cplus also contains system software with all basic functions for operating and programming, including two built-in Ethernet channels with 100 Mbit/s capacity. This ensures a significant increase in computing power as well as improved controller monitoring and supervision.



# IRB 140

## Industrial Robot

### TECHNICAL DATA, IRB 140 INDUSTRIAL ROBOT

#### SPECIFICATION

Robot versions	Handling capacity	Reach of 5th axis	Remarks
IRB 140	5 kg	810 mm	Foundry protection Clean Room
IRB 140F	5 kg	810 mm	
IRB 140CR	5 kg	810 mm	
IRB 140T	5 kg	810 mm	

Supplementary load (on upper arm alt. wrist)	
on upper arm	1 kg
on wrist	0.5 kg

Number of axes	
Robot manipulator	6
External devices	6

Integrated signal supply	12 signals on upper arm
--------------------------	-------------------------

Integrated air supply	Max. 8 bar on upper arm
-----------------------	-------------------------

#### PERFORMANCE

Position repeatability	0.03 mm (average result from ISO test)
------------------------	--

Axis movement	
Axis	Working range
1, C Rotation	360°
2, B Arm	200°
3, A Arm	280°
4, D Wrist	Unlimited (400° default)
5, E Bend	240°
6, P Turn	Unlimited (800° default)

Max. TCP velocity	2.5 m/s
Max. TCP acceleration	20 m/s <sup>2</sup>
Acceleration time 0-1 m/s	0.15 sec

#### VELOCITY

Axis no.	IRB 140	IRB 140T
1	200°/s	250°/s
2	200°/s	250°/s
3	260°/s	260°/s
4	360°/s	360°/s
5	360°/s	360°/s
6	450°/s	450°/s

#### CYCLE TIME

5 kg Picking side cycle 25 x 300 x 25 mm	IRB 140	IRB 140T
	0,85s	0,77s

#### WORKING RANGE AND LOAD DIAGRAM

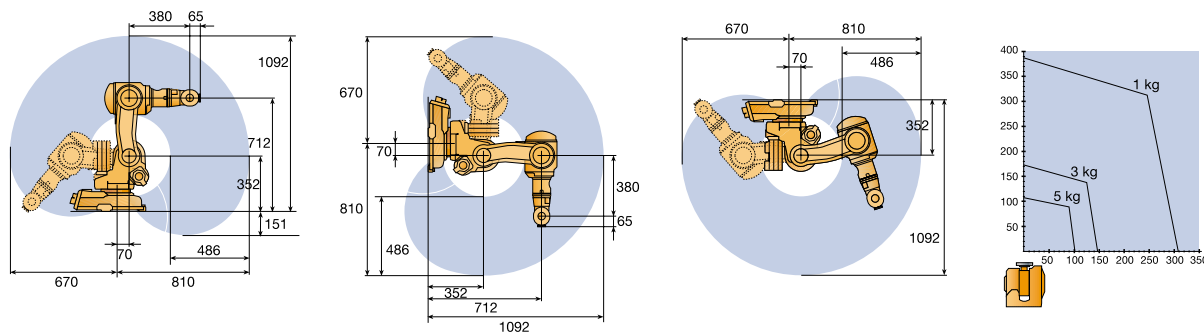

#### ELECTRICAL CONNECTIONS

Supply voltage	200–600 V, 50/60 Hz
Rated power	
Transformer rating	4.5 kVA

#### PHYSICAL

Robot mounting	Any angle
----------------	-----------

Dimensions	
Robot base	400 x 450 mm
Robot controller H x W x D	950 x 800 x 620 mm

Weight	
Robot manipulator	98 kg
Robot controller	250 kg

#### ENVIRONMENT

Ambient temperature	
Robot manipulator	5 – 45°C
Robot controller	5 – 52°C

Relative humidity	Max. 95%
-------------------	----------

Degree of protection, Manipulator	
Foundry/Clean Room	IP67
Clean Room	High pressure steam washable Class 10

Controller	Air cooled
Computer system	Totally enclosed

Noise level	Max. 70 dB (A)
Safety	Double circuits with supervision, emergency stops and safety functions, 3-position enable device

Emission EMC/EMI-shielded

Data and dimensions may be changed without notice

