

ABB GENERAL PURPOSE DRIVES

ACS560 drives (0.75 to 160 kW, 1.0 to 215 hp)

Hardware manual



ACS560 drives (0.75 to 160 kW, 1.0 to 215 hp)

Hardware manual

Table of contents



1. Safety instructions



4. Mechanical installation



6. Electrical installation



Table of contents

1 Safety instructions

Contents of this chapter	13
Use of warnings and notes	13
General safety in installation, start-up and maintenance	14
Electrical safety in installation, start-up and maintenance	16
Electrical safety precautions	16
Additional instructions and notes	16
Optical components	17
Printed circuit boards	17
Grounding	17
Additional instructions for permanent magnet motor drives	19
Safety in installation, start-up, maintenance	19
Safety in operation	19
General safety in operation	19

2 Introduction to the manual

Contents of this chapter	21
Applicability	21
Target audience	21
Purpose of the manual	21
Categorization by frame (size)	21
Quick installation and commissioning flowchart	22
Terms and abbreviations	23
Related documents	24

3 Operation principle and hardware description

Contents of this chapter	27
Operation principle	27
Layout	28
Frames R0...R2	28
Frame size R3	30
Frame R4...R8	31
Overview of power and control connections	31
External control connecting terminal, Frame size R0...R2	33
External control connecting terminal, Frame size R3...R5	34
External control connection terminals, frames R6...R8	35
Mounted options	35
Control panel	36
Type designation label	37
Locations of the labels on the drive	38
Type designation key	39

4 Mechanical installation

Contents of this chapter	41
Safety	41



Checking the installation site	42
Required tools	43
Moving the drive	43
Unpacking and examining delivery, frames R0...R2	44
Unpacking and examining delivery, frames R3...R4	44
Unpacking and examining delivery, frames R5	45
Unpacking and examining delivery, frames R6...R8	46
Installing the drive	48
Installing the drive vertically, frames size R0...R2	48
Installing the drive vertically, frame size R3...R4	49
Installing the drive vertically, frames size R5...R8	50
Installing the drive vertically side by side	51
Installing the drive horizontally side by side	51
 5 Planning the electrical installation	
Contents of this chapter	53
Selecting the supply disconnecting device	53
European Union	53
Other regions	54
Checking the compatibility of the motor and drive	54
Selecting the power cables	54
General rules	54
Typical power cable sizes	54
Alternative power cable types	55
Recommended power cable types	56
Power cable types for limited use	56
Not allowed power cable types	56
Motor cable shield	56
Conduit	57
Armored cable / shielded power cable	57
Selecting the control cables	57
Shielding	57
Signals in separate cables	58
Signals allowed to be run in the same cable	58
Relay cable	58
Control panel cable	58
Drive composer PC tool cable	58
Routing the cables	59
General guidelines, IEC	59
General guidelines, North America	60
Continuous motor cable shield or enclosure for equipment on the motor cable ...	61
Separate control cable ducts	61
Implementing thermal overload and short-circuit protection	61
Protecting the input cabling and the drive upon a short-circuit	61
Protecting the motor and motor cable in short-circuits	61
Protecting the drive and the power cables against thermal overload	61
Protecting the motor against thermal overload	62
Protecting the drive against ground faults	62
Residual current device compatibility	62
Implementing the Emergency stop function	62
Implementing the Safe torque off function	62
Implementing the undervoltage control (power-loss ride-through)	62



Using a contactor between the drive and the motor	63
Implementing a bypass connection	63
Example bypass connection	63
Switching the motor power supply from drive to direct-on-line	64
Switching the motor power supply from direct-on-line to drive	65
Protecting the contacts of relay outputs	65
6 Electrical installation	
Contents of this chapter	67
Warnings	67
Required tools	67
Checking the insulation of the assembly	67
Drive	67
Input power cable	68
Checking the insulation of the motor and motor cable	68
Brake resistor assembly R0...R3	68
Checking the compatibility with IT (ungrounded) and corner-grounded TN systems ...	69
EMC filter	69
Ground-to-phase varistor	69
Frames R0...R3	70
Frames R4...R8	71
Connecting the power cables	73
Connection diagram	73
Connection procedure: frames R0...R2	75
Motor cable	75
Input power cable	76
Finalization	77
Connection procedure, frames R3...R4	79
Motor cable	79
Note:	80
Input power cable	80
Finalization	81
Connection procedure, frames R5...R8	83
Motor cable	83
Input power cable	84
DC connection	87
Connecting the control cables	87
Default control connections of ABB standard macro	88
Connection diagram	88
Terminal sizes	89
Notes:	89
Switches	90
PNP configuration for digital inputs	90
NPN configuration for digital inputs	90
Connection for obtaining 0...10 V from analog output 2 (AO2)	91
Connection examples of two-wire and three-wire sensors	91
DI5 as frequency input	92
AI1 and AI2 as Pt100 sensor inputs (X1)	92
Safe torque off (X4)	93
Control cable connection procedure R0...R8	93
R0...R2	95
R3...R5	96



R6...R8	97
Auxiliary voltage connection (For R0...R2 frames with optional BAPO-01 module)	97
Option modules	99
To install a front option	100
Front option slot 1	100
Front option slot 2 (applicable for R3...R5 frames)	101
To remove a front option	102
To install a side option	102
To remove a side option	103
Wiring the modules	103
Reinstalling covers	103
Reinstalling cover, frames size R0...R2	103
Reinstalling covers, frame size R3, R4	104
Reinstalling side plates and covers, frames size R5...R8	104
Connecting a PC	105

7 Installation checklist of the drive

Contents of this chapter	107
Checklist	107

8 Maintenance and hardware diagnostics

Contents of this chapter	109
Maintenance intervals	109
Description of symbols	109
Recommended annual maintenance actions by the user	110
Recommended maintenance action by the user	110
Heatsink	111
Fans	111
Replacing the cooling fan, frames size R0...R4	112
Replacing the main cooling fan, frame R5	112
Replacing the main cooling fan, frames size R6...R8	113
Replacing the auxiliary cooling fan, frames R6...R8	114
Capacitors	115
Reforming the capacitors	115
Control panel	115
Cleaning the control panel	115
Replacing the battery in the control panel	115
LEDs	116
Drive LEDs (R3~R8)	116
Control panel LEDs	116

9 Technical data

Contents of this chapter	119
Ratings	119
IEC ratings	119
Definitions	121
Sizing	121
Derating	121
Ambient temperature derating, IP20	122
Switching frequency derating	122
Altitude derating	123

Fuses (IEC)	123
uR and aR fuse	123
gG fuses	124
gR fuses	125
Circuit breakers	127
Dimensions, weights and free space requirements	128
Standard frame size (R0-R8)	128
Thermal losses, cooling data and noise	129
Terminal and lead-through data for the power cables	130
Terminal and lead-through data for the control cables	131
Electrical power network specification	132
Motor connection data	132
EMC compatibility and motor cable length	133
Brake resistor connection data for frames R0...R3	134
Control connection data	134
Auxiliary circuit power consumption	138
Efficiency	139
Degree of protection	139
Ambient conditions	139
Materials	140
Applicable standards	140
CE marking	141
Compliance with the European EMC Directive	141
Compliance with the European ROHS II Directive 2011/65/EU	141
Compliance with the EN 61800-3:2004 + A1:2012	141
Definitions	141
Category C1	142
Category C2	142
Category C3	142
Category C4	143
 10 Dimension drawings	
Contents of this chapter	145
Frame R0, IP20	146
Frame R1, IP20	147
Frame R2, IP20	147
Frame R3, IP20	148
Frame R4, IP20	149
Frame R5, IP20	150
Frame R6, IP20	151
Frame R7, IP20	152
Frame R8, IP20	153
 11 Resistor braking	
Contents of this chapter	155
Operation principle and hardware description	155
Resistor braking, frames R0...R3	155
Planning the braking system	155
Selecting the brake resistor	155
Selecting and routing the brake resistor cables	157
Placing the brake resistor	158



Protecting the system in brake circuit fault situations	158
Mechanical installation	159
Electrical installation	159
Start-up	159
Resistor braking, frames R4...R8	159
Planning the braking system	159

12 The Safe torque off function

Contents of this chapter	161
Description	161
Compliance with the European Machinery Directive	162
Wiring	163
Connection principle (R0...R2)	163
Connection with internal power supply	163
Connection with external power supply	163
Wiring examples (R0...R2)	164
Wiring with internal power supply	164
Wiring with external power supply	164
Connection principle (R3...R8)	165
Connection with internal power supply	165
Connection with external power supply	165
Wiring examples (R3...R8)	166
Wiring with internal power supply	166
Wiring with external power supply	166
Activation switch	166
Cable types and lengths	167
Grounding of protective shields	167
Operation principle	168
Start-up including acceptance test	169
Competence	169
Acceptance test reports	169
Acceptance test procedure	169
Use	171
Maintenance	172
Competence	172
Fault tracing	173
Safety data	174
Abbreviations	175

13 Optional I/O and power extension modules

Contents of this chapter	177
BIO-01 I/O extension module	177
Contents of this chapter	177
Safety instructions	177
BIO-01 product overview	177
Mechanical installation	178
Electrical installation	179
Start-up	180
Technical data	180
CMOD-02 multifunction extension module (external 24 V AC/DC)	181
Hardware description	181

Mechanical installation	182
Unpacking and checking the delivery	182
Installing the module	183
Electrical installation	183
General cabling instructions	183
Wiring	183
Start-up	184
Diagnostics	184
Technical data	184
BAPO-01 power extension module	186
Contents of this chapter	186
Safety instructions	187
Hardware description	187
Mechanical installation	188
Electrical installation	188
Start-up	188
Technical data	188
14 RDUM-01 blank control panel	
Layout	189
Example: Connecting a RDUM-01 panel to an assistant or basic control panel mounted on a cabinet door	190
Installing assistant or basic control panel on the cabinet door	190
15 External input choke	
Contents of this chapter	191
Why external input chokes are required?	191
Specification	191
External input choke types	192
Mechanical dimensions	192
Specification	193
16 du/dt filters	
Contents of this chapter	195
du/dt filters	195
Where is a du/dt filter needed?	195
du/dt filter types	195
Description, installation and technical data of the FOCH filters	196
Description, installation and technical data of the AOCH and NOCH filters	196

Further information



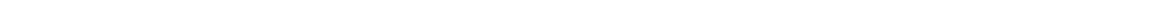

1

Safety instructions

Contents of this chapter

This chapter contains the safety instructions which you must obey when you install, start up, operate and do maintenance work on the drive. If you ignore the safety instructions, injury, death or damage can occur.

Use of warnings and notes

Warnings tell you about conditions which can cause injury or death, or damage to the equipment. They also tell you how to prevent the danger. Notes draw attention to a particular condition or fact, or give information on a subject.

The manual uses these warning symbols:

**WARNING!**

Electricity warning tells about hazards from electricity which can cause injury or death, or damage to the equipment.

**WARNING!**

General warning tells about conditions, other than those caused by electricity, which can cause injury or death, or damage to the equipment.

**WARNING!**

Electrostatic sensitive devices warning tells you about the risk of electrostatic discharge which can cause damage to the equipment.



General safety in installation, start-up and maintenance

These instructions are for all personnel who do work on the drive.



WARNING!

Obey these instructions. If you ignore them, injury or death, or damage to the equipment can occur.

- Keep the drive in its package until you install it. After unpacking, protect the drive from dust, debris and moisture.
- Use the required personal protective equipment: safety shoes with metal toe cap, safety glasses, protective gloves, etc.
- Lift a heavy drive with a lifting device. Use the designated lifting points. See the dimension drawings.
- Be careful when handling a tall module. The module overturns easily because it is heavy and has a high center of gravity. Whenever possible, secure the module with chains. Do not leave an unsupported module unattended especially on a sloping floor.



- Beware of hot surfaces. Some parts, such as heatsinks of power semiconductors, and brake resistors, remain hot for a while after disconnection of the electrical supply.
- Vacuum clean the area around the drive before the start-up to prevent the drive cooling fan from drawing the dust inside the drive.
- Make sure that there is sufficient cooling. See the technical data.
- Before you connect voltage to the drive, make sure that all covers are in place. Do not remove the covers when voltage is connected.
- Before you adjust the drive operation limits, make sure that the motor and all driven equipment can operate throughout the set operation limits.
- Before you activate the automatic fault reset or automatic restart functions of the drive control program, make sure that no dangerous situations can occur. These functions reset the drive automatically and continue operation after a fault or supply break. If these functions are activated, the installation must be clearly marked as defined in IEC/EN 61800-5-1, subclause 6.5.3, for example, "THIS MACHINE STARTS AUTOMATICALLY".
- The maximum number of drive power-ups is five in ten minutes. Too frequent power-ups can damage the charging circuit of the DC capacitors.
- Validate any safety circuits (for example, Safe torque off or emergency stop) in start-up. See separate instructions for the safety circuits.
- Beware of hot air exiting from the air outlets.
- Do not cover the air inlet or outlet when the drive is running.

Note:

- If you select an external source for the start command and it is on, the drive will start immediately after fault reset unless you configure the drive for pulse start. See the firmware manual.
- Depending on the wiring and parametrization of the drive, the stop key on the control panel may not stop the drive.
- Only authorized persons are allowed to repair a malfunctioning drive.



Electrical safety in installation, start-up and maintenance

■ Electrical safety precautions

These electrical safety precautions are for all personnel who do work on the drive, motor cable or motor.



WARNING!

Obey these instructions. If you ignore them, injury or death, or damage to the equipment can occur. If you are not a qualified electrician, do not do installation or maintenance work. Go through these steps before you begin any installation or maintenance work.

1. Clearly identify the work location and equipment.
2. Disconnect all possible voltage sources. Lock and tag.
 - Open the main disconnecting device of the drive.
 - If you have a permanent magnet motor connected to the drive, disconnect the motor from the drive with a safety switch or by other means.
 - Make sure that re-connection is not possible.
 - Disconnect any external power sources from the control circuits.
 - After you disconnect the drive, always wait 5 minutes to let the intermediate circuit capacitors discharge before you continue.
3. Protect any other energized parts in the work location against contact.
4. Take special precautions when close to bare conductors.
5. Measure that the installation is de-energized.
 - Use a multimeter with an impedance of at least 1 Mohm.
 - Make sure that the voltage between the drive input power terminals and the grounding (PE) busbar is close to 0 V.
 - Make sure that the voltage between the drive DC terminals (UDC+ and UDC-) and the grounding terminal (PE) is close to 0 V.
 - If you have a permanent magnet motor connected to the drive, make sure that the voltage between the drive output terminals and the grounding (PE) busbar is close to 0 V.
6. Install temporary grounding as required by the local regulations.
7. Ask the person in control of the electrical installation work for a permit to work.



■ Additional instructions and notes



WARNING!

Obey these instructions. If you ignore them, injury or death, or damage to the equipment can occur.

- If you are not a qualified electrician, do not do electrical installation or maintenance work.
- Do not install the drive if the electrical power network, motor/generator, or environmental conditions do not agree with the drive data.
- Do not do insulation or voltage withstand tests on the drive.

Note:

- The motor cable terminals of the drive are at a dangerous voltage when the input power is on, regardless of whether the motor is running or not.
- When the input power is on, the drive DC bus is at a dangerous voltage.
- External wiring can supply dangerous voltages to the relay outputs of the control units of the drive.
- The Safe torque off function does not remove the voltage from the main and auxiliary circuits. The function is not effective against deliberate sabotage or misuse.

Optical components**WARNING!**

Obey these instructions. If you ignore them, damage to the equipment can occur.

- When you unplug the fibre optic cables, always hold the connector, not the cable itself.
- Do not touch the ends of the fibers with bare hands as the ends are extremely sensitive to dirt.
- Do not bend the fiber optic cables too tightly. The minimum allowed bend radius is 35 mm (1.4").

Printed circuit boards**WARNING!**

Use a grounding wrist band when you handle printed circuit boards. Do not touch the boards unnecessarily. The boards contain components sensitive to electrostatic discharge.

■ Grounding

These instructions are for all personnel who are responsible for the grounding of the drive.

**WARNING!**

Obey these instructions. If you ignore them, injury or death, or equipment malfunction can occur, and electromagnetic interference can increase.

- If you are not a qualified electrician, do not do grounding work.
- Always ground the drive, the motor and adjoining equipment. This is necessary for the personnel safety. Proper grounding also reduces electromagnetic emission and interference.
- Make sure that the conductivity of the protective earth PE conductors is sufficient. See the electrical planning instructions of the drive. Obey the local regulations.
- Connect the power cable shields to protective earth terminals of the drive to make sure of personnel safety.
- Make a 360° grounding of the power and control cable shields at the cable entries to suppress electromagnetic disturbances.
- In a multiple-drive installation, connect each drive separately to the protective earth (PE) busbar of the power supply.

Note:

- You can use power cable shields as grounding conductors only when their conductivity is sufficient.



18 Safety instructions

- IEC/EN 61800-5-1 (section 4.3.5.5.2.) requires that as the normal touch current of the drive is higher than 3.5 mA AC or 10 mA DC, you must use a fixed protective earth (PE) connection. The minimum size of the protective earthing conductor must comply with the local safety regulations for high protective earthing conductor current equipment. See the electrical planning instructions of the drive, and standard IEC/EN 61800-5-1, 4.3.5.5.2.

In addition,

- use a protective earth conductor with a cross-section of at least 10 mm² Cu or 16 mm² Al,
or
- use a second protective earth conductor of the same cross-sectional area as the original protective earthing conductor,
or
- use a device which automatically disconnects the supply if the protective earth conductor breaks.



Additional instructions for permanent magnet motor drives

■ Safety in installation, start-up, maintenance

These are additional warnings concerning permanent magnet motor drives. The other safety instructions in this chapter are also valid.



WARNING!

Obey these instructions. If you ignore them, injury or death and damage to the equipment can occur.

- Do not do work on the drive when a rotating permanent magnet motor is connected to it. A rotating permanent magnet motor energizes the drive including its input and output power terminals.

Before installation, start-up and maintenance work on the drive:

- Stop the drive and do the steps in section [Electrical safety precautions \(page 16\)](#).
- Disconnect the motor from the drive with a safety switch or by other means.
- If you cannot disconnect the motor, make sure that the motor cannot rotate during work. Make sure that no other system, like hydraulic crawling drives, can rotate the motor directly or through any mechanical connection like felt, nip, rope, etc.
- Measure that the installation is de-energized.
 - Use a multimeter with an impedance of at least 1 Mohm.
 - Make sure that the voltage between the drive output terminals and the grounding (PE) busbar is close to 0 V.
 - Make sure that the voltage between the drive input power terminals and the grounding (PE) busbar is close to 0 V.
 - Make sure that the voltage between the drive DC terminals (if any) and the grounding (PE) terminal is close to 0 V.
- Install temporary grounding to the drive output terminals (U2, V2, W2). Connect the output terminals together as well as to the PE.

During the start up:

- Make sure that the motor cannot be run into overspeed, e.g. driven by the load. Motor overspeed causes overvoltage that can damage or destroy the capacitors in the intermediate circuit of the drive.

■ Safety in operation



WARNING!

Make sure that the motor cannot be run into overspeed, e.g. driven by the load. Motor overspeed causes overvoltage that can damage or destroy the capacitors in the intermediate circuit of the drive.

General safety in operation

These instructions are for all personnel that operate the drive.



WARNING!

Obey these instructions. If you ignore them, injury or death, or damage to the equipment can occur.

- Do not power up the drive more than five times in ten minutes. Too frequent power-ups can damage the charging circuit of the DC capacitors. If you need to start or stop the drive, use the control panel start and stop keys or commands through the I/O terminals of the drive.
- Give a stop command to the drive before you reset a fault. If you have an external source for the start command and the start is on, the drive will start immediately after the fault reset, unless you configure the drive for pulse start. See the firmware manual.
- Before you activate automatic fault reset functions of the drive control program, make sure that no dangerous situations can occur. These functions reset the drive automatically and continue operation after a fault.

Note:

When the control location is not set to Local, the stop key on the control panel will not stop the drive.



2

Introduction to the manual

Contents of this chapter

The chapter describes applicability, target audience and purpose of this manual. It describes the contents of this manual and refers to a list of related manuals for more information. The chapter also contains a flowchart of steps for checking the delivery, installing and commissioning the drive. The flowchart refers to chapters/sections in this manual.

Applicability

The manual applies to the ACS560 drives.

Target audience

The reader is expected to know the fundamentals of electricity, wiring, electrical components and electrical schematic symbols.

The manual is written for readers worldwide. Both SI and imperial units are shown. Special US instructions for installations in the United States are given.

Purpose of the manual

This manual provides information needed for planning the installation, installing, and servicing the drive.

Categorization by frame (size)

The ACS560 is manufactured in frames (frame sizes) R0...R8. Some instructions and other information which only concern certain frames are marked with the symbol of the frame (R0...R8). The frame is marked on the type designation label attached to the drive, see section [Type designation label \(page 37\)](#).

Quick installation and commissioning flowchart

Task	See
Identify the frame of your drive: R0...R8.	<i>Type designation label (page 37)</i>
↓	
Plan the installation: select the cables, etc.	<i>Planning the electrical installation (page 53)</i>
Check the ambient conditions, ratings and required cooling air flow.	<i>Technical data (page 119)</i>
↓	
Unpack and check the drive.	<i>Mechanical installation: Unpacking and examining delivery, frames R0...R2 (page 44), Unpacking and examining delivery, frames R3...R4 (page 44), Unpacking and examining delivery, frames R5 (page 45), Unpacking and examining delivery, frames R6...R8 (page 46).</i>
↓	
If the drive will be connected to an IT (ungrounded) system, check that the internal EMC filter and ground-to-phase varistor are not connected. If the drive will be connected to a corner-grounded TN system, check that the internal EMC filter is not connected.	<i>Operation principle and hardware description: Type designation label (page 37)</i> <i>Electrical installation: Checking the compatibility with IT (ungrounded) and corner-grounded TN systems (page 69)</i>
↓	
Install the drive on a wall.	<i>Mechanical installation (page 41)</i>
↓	
Route the cables.	<i>Planning the electrical installation: (page 59)</i>
↓	
Check the insulation of the input cable and the motor and the motor cable.	<i>Electrical installation: Checking the insulation of the assembly (page 67)</i>
↓	
Connect the power cables.	<i>Electrical installation: Connecting the power cables (page 73)</i>
↓	
Connect the control cables.	<i>Electrical installation: Connecting the control cables (page 87)</i>
↓	
Check the installation.	<i>Installation checklist: Installation checklist of the drive (page 107)</i>

Task**See**

Commission the drive.

ACS560 standard control program firmware manual
(3AXD50000044997 [English])

Terms and abbreviations

Term/ Abbreviation	Description
ACS-AP-x	Assistant control panel
ACS-BP-S	Basic control panel
BAPO	Optional auxiliary power extension module
BCBL-01	Optional USB to RJ45 cable
BIO-01	Optional I/O extension module underneath the fieldbus adapter module
Brake chopper	Conducts the surplus energy from the intermediate circuit of the drive to the brake resistor when necessary. The chopper operates when the DC link voltage exceeds a certain maximum limit. The voltage rise is typically caused by deceleration (braking) of a high inertia motor.
Brake resistor	Dissipates the drive surplus braking energy conducted by the brake chopper to heat
Control board	Circuit board in which the control program runs
DC link	DC circuit between rectifier and inverter
DC link capacitors	Energy storage which stabilizes the intermediate circuit DC voltage
DPMP	Optional mounting platform for door mounting of control panel
DPMP-01	Mounting platform for control panel (flush mounting)
DPMP-02	Mounting platform for control panel (surface mounting)
EFB	Embedded fieldbus
FBA	Fieldbus adapter
FCAN	Optional CANopen adapter module
FCNA-01	Optional ControlNet™ adapter module
FECA-01	Optional EtherCAT adapter module
FENA-01	Optional Ethernet adapter module for EtherNet/IP™, Modbus TCP and PROFINET IO protocols
FENA-11	Optional Ethernet adapter module for EtherNet/IP™, Modbus TCP and PROFINET IO protocols
FENA-21	Optional Ethernet adapter module for EtherNet/IP™, Modbus TCP and PROFINET IO protocols, 2-port
FPBA-01	Optional PROFIBUS DP adapter module
Frame, frame size	Physical size of the drive or power module
IGBT	Insulated gate bipolar transistor
Intermediate circuit	DC circuit between rectifier and inverter
Inverter	Converts direct current and voltage to alternating current and voltage.
Macro	A pre-defined set of default values of parameters in a drive control program.
NETA-21	Remote monitoring tool
Network control	With fieldbus protocols based on the Common Industrial Protocol (CIPTM), such as DeviceNet and Ethernet/IP, denotes the control of the drive using the Net Ctrl and Net Ref objects of the ODVA AC/DC Drive Profile. For more information, see www.odva.org .
Parameter	In the drive control program, user-adjustable operation instruction to the drive, or signal measured or calculated by the drive. In some (for example fieldbus) contexts, a value that can be accessed as an object, eg, variable, constant, or signal.
PLC	Programmable logic controller
RDUM-01	Optional blank control panel cover

Term/ Abbreviation	Description
Rectifier	Converts alternating current and voltage to direct current and voltage
RIIO-01	Inbuilt I/O module
STO	Safe torque off (IEC/EN 61800-5-2)

Related documents

Manual	Code (English)	Code (Hindi)
Drive hardware manuals and guides		
<i>ACS560 standard control program firmware manual</i>	3AXD50000044997	3AXD50000045887
<i>ACS560 (0.75 to 160 kW, 1.0 to 215 hp) hardware manual</i>	3AXD50000044998	3AXD50000045888
<i>ACS560 drives quick installation and start-up guide</i>	3AXD50000042620	(Multi Lingual)
<i>ACS-AP-x assistant control panels user's manual</i>	3AUA0000085685	
<i>ACS-BP-S basic control panels user's manual</i>	3AXD50000032527	
Option manuals and guides		
<i>CPTC-02 ATEX-certified thermistor protection module, Ex II (2) GD (+L537+Q971) user's manual</i>	3AXD50000032016	
<i>CDPI-0x communication adapter module user's manual</i>	3AXD50000009929	
<i>DPMP-01 mounting platform for ACS-AP control panel</i>	3AUA0000100140	
<i>DPMP-02/03 mounting platform for ACS-AP control panel</i>	3AUA0000136205	
<i>FCAN-01 CANopen adapter module user's manual</i>	3AFE68615500	
<i>FCNA-01 ControlNet adapter module user's manual</i>	3AUA0000141650	
<i>FDNA-01 DeviceNet™ adapter module user's manual</i>	3AFE68573360	
<i>FECA-01 EtherCAT adapter module user's manual</i>	3AUA0000068940	
<i>FENA-01/-11/-21 Ethernet adapter module user's manual</i>	3AUA0000093568	
<i>FPBA-01 PROFIBUS DP adapter module user's manual</i>	3AFE68573271	
<i>FSCA-01 RS-485 adapter module user's manual</i>	3AUA0000109533	
<i>Flange mounting kit installation supplement</i>	3AXD50000019100	
<i>Flange mounting kit quick installation guide for ACX580-01 frames R0 to R5</i>	3AXD50000036610	
<i>Flange mounting kit quick installation guide for ACS880-01 and ACX580-01 frames R6 to R8</i>	3AXD50000019099	
Tool and maintenance manuals and guides		
<i>Drive composer PC tool user's manual</i>	3AUA0000094606	
<i>Converter module capacitor reforming instructions</i>	3BFE64059629	
<i>NETA-21 remote monitoring tool user's manual</i>	3AUA00000969391	

Manual	Code (English)	Code (Hindi)
<i>NETA-21 remote monitoring tool installation and startup guide</i>	3AJA0000096881	

You can find manuals and other product documents in PDF format on the Internet. See section *Document library on the Internet* on the inside of the back cover. For manuals not available in the Document library, contact your local ABB representative.



[ACS560 manuals](#)

See www.abb.com/drives/documents for all manuals on the internet.

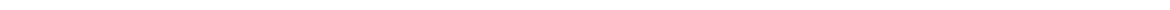



Operation principle and hardware description

Contents of this chapter

This chapter briefly describes the operation principle, layout, type designation label and type designation information. It also shows a general diagram of power connections and control interfaces.

Operation principle

The ACS560 is a drive for controlling asynchronous AC induction motors.

The figure below shows the simplified main circuit diagram of the drive.

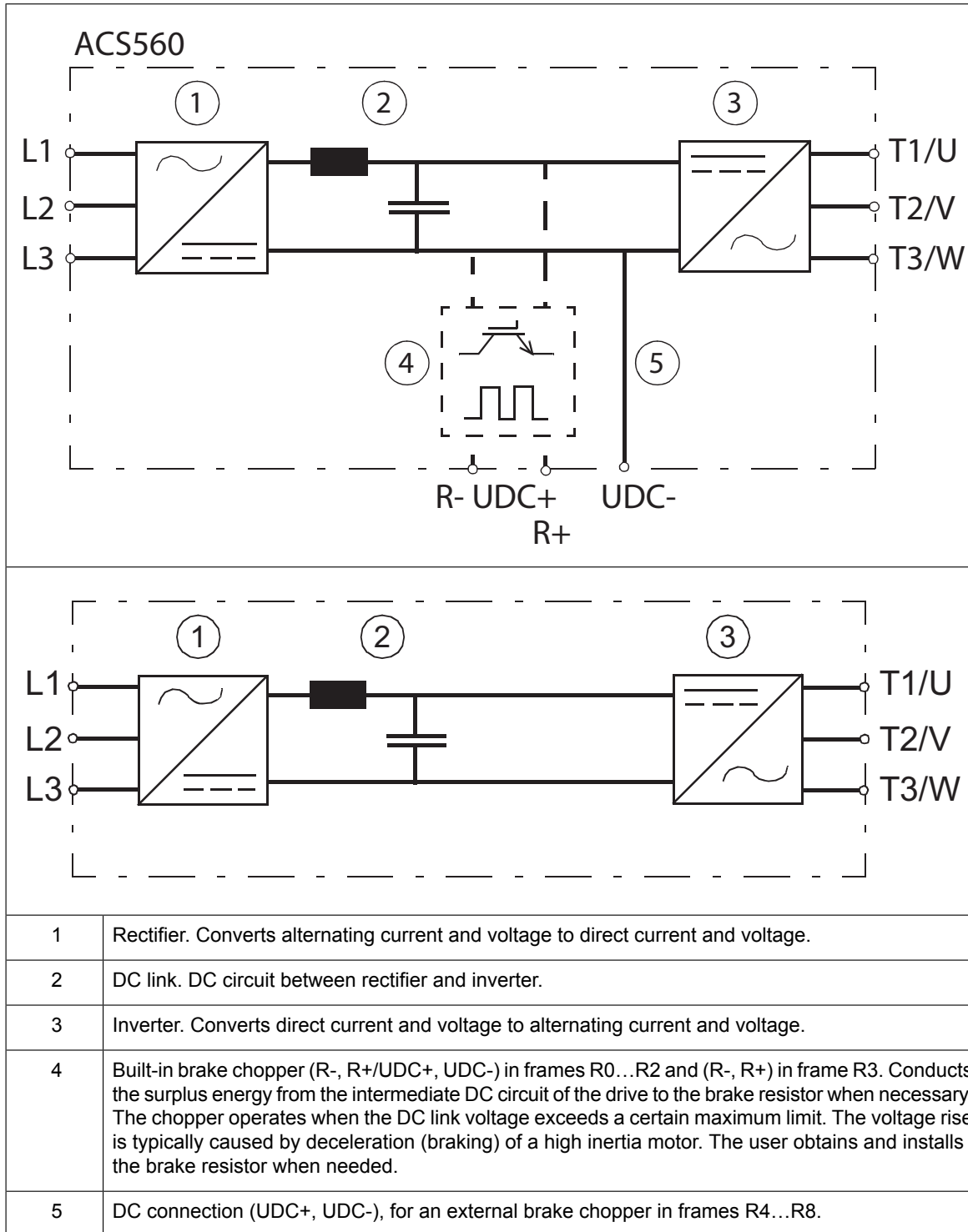

Layout

■ Frames R0...R2

The layout of a frame R0 drive is presented below. The frame sizes R1...R2 is similar to R0 but have a different structure.

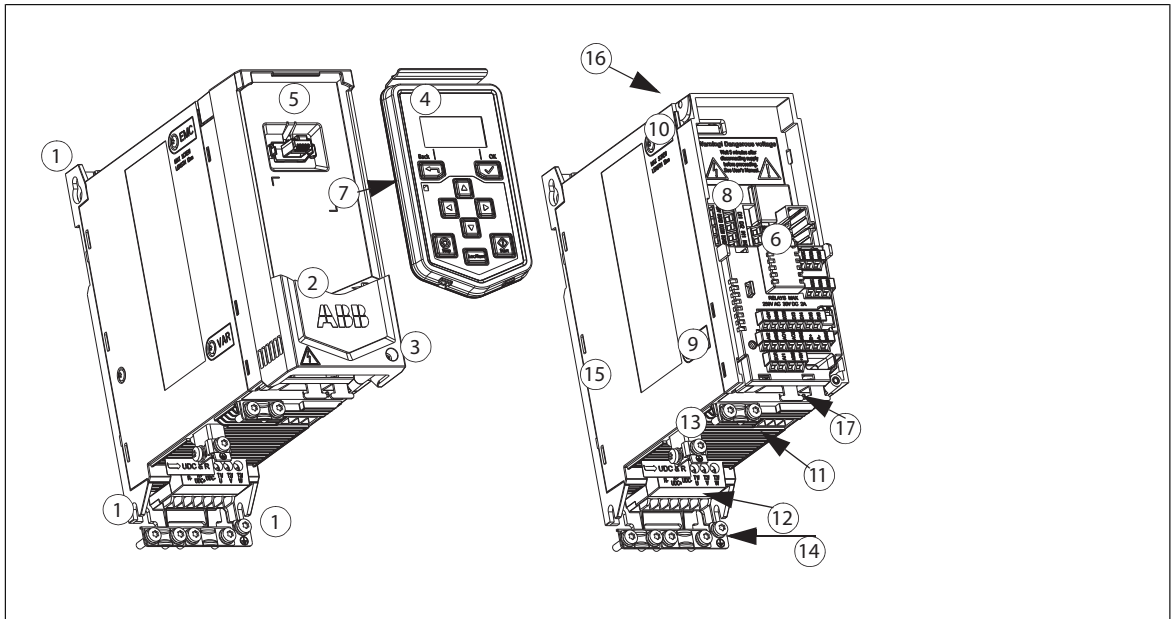

1	Installation point (4)	10	EMC filter grounding screw (EMC). <u>R0...R2:</u> on the left side of drive.
2	Cover plate	11	Input voltage connection (L1, L2, L3).
3	Cover plate screw	12	Motor connection (T1/U, T2/V, T3/W) and brake connection (R-, R+/UDC+, UDC-).
4	Control panel	13	PE connection (power line)
5	Control panel connection	14	Earthing connection (motor)
6	CCA-01 interface	15	Other earthing connections
7	For LED of normal power supply and failure, see section LEDs (page 116) .	16	Fan
8	I/O connection. See section External control connecting terminal, Frame size R0...R2 (page 33) .	17	Cable bundle installation position of I/O cable
9	Voltage dependent resistor grounding screw (VAR)		

■ Frame size R3

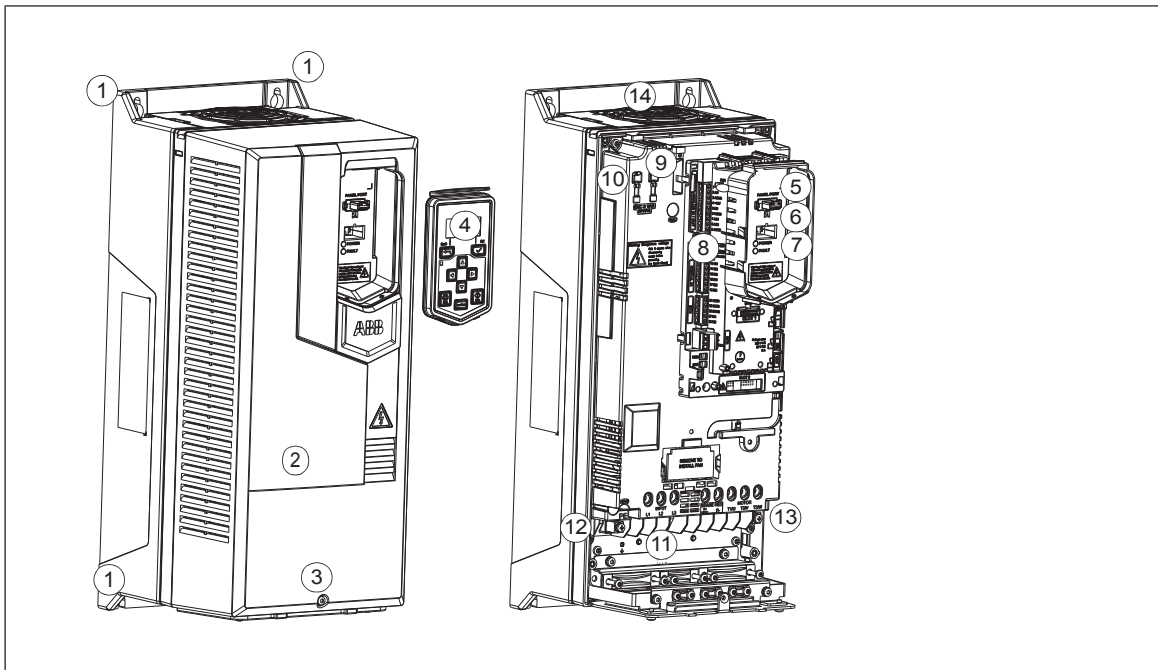

1	Installation point (4)	10	EMC filter grounding screw (EMC).
2	Cover plate	11	Input voltage connection (L1, L2, L3), motor connection (T1/U, T2/V, T3/W) and brake connection (R-, R+).
3	Cover plate screw	12	PE connection (power line)
4	Control panel	13	Earthing connection (motor)
5	Control panel connection	14	Fan
6	CCA-01 interface		
7	For LED of normal power supply and failure, see section <i>LEDs</i> (page 116).		
8	I/O connection. See section <i>External control connecting terminal, Frame size R3...R5</i> (page 34).		
9	Voltage dependent resistor grounding screw (VAR)		

■ Frame R4...R8

The layout of a frame R6 drive is presented below. The frame sizes R7...R8 is similar but have a different structure.

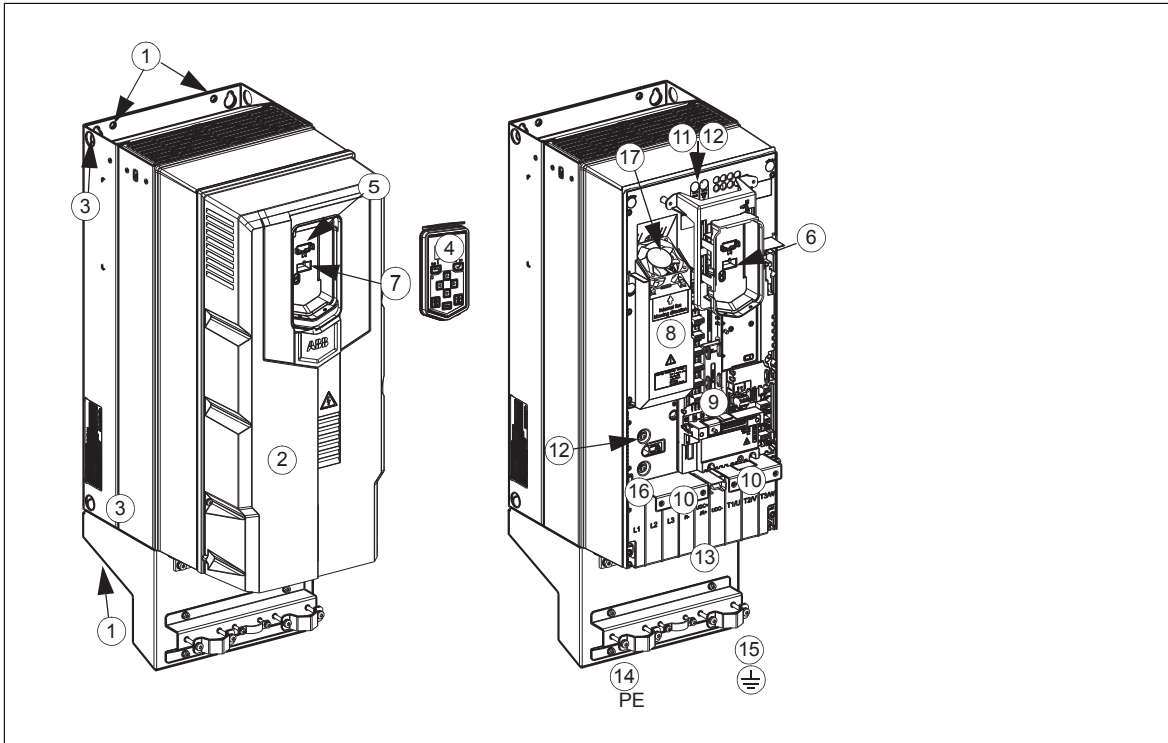

1	Installation point (2 points on the top and 2 points on the bottom of the frame body)	11	Voltage dependent resistor ground screw (VAR), arranged below the control tray.
2	Cover plate	12	Two EMC filter ground screws, one arranged below the control tray bracket and the other arranged on the left and above the protective cover.
3	Lifting hole	13	Protective cover. Below the protective cover: input voltage connection (L1, L2, L3), motor connection (T1/U, T2/V, T3/W) and DC connection (UDC+, UDC-).
4	Basic control panel	14	PE connection (power line)
5	Control panel connection	15	Earthing connection (motor)
6	CCA-01 interface	16	A primary fan
7	For LED of normal power supply and failure, see section LEDs (page 116) .	17	Auxiliary fan
8	I/O connection. See section External control connection terminals, frames R6...R8 (page 35) .		
9	Cable bundle installation position of I/O cable		
10	Mechanical support clamp of I/O cable		

Overview of power and control connections

The logical diagram below shows the power connections and control interfaces of the drive.

32 Operation principle and hardware description

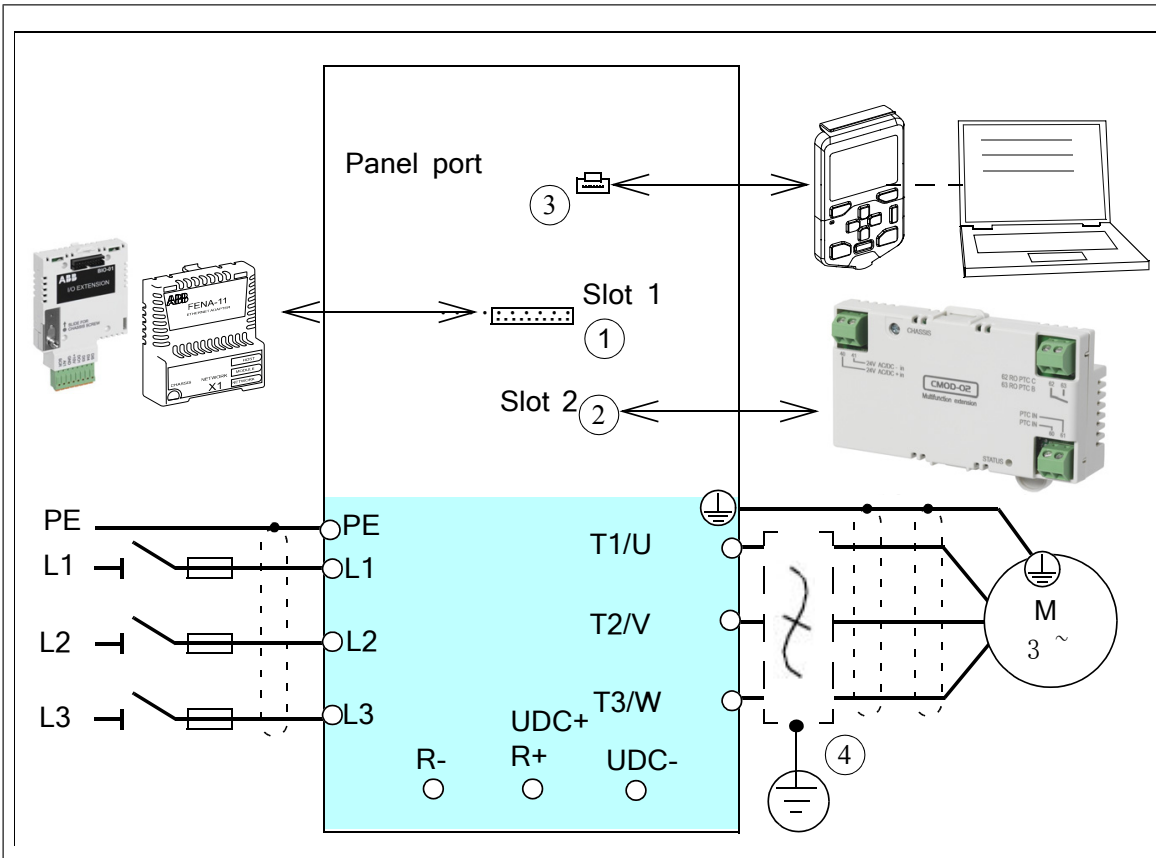

1	Option slot 1 for I/O extension module or/and fieldbus adapter modules
2	Option slot 2 for 24V external power extension CMOD-02
3	Panel port
4	du/dt filter, see page 195.

■ External control connecting terminal, Frame size R0...R2

The figure below explains the external control connecting terminal layout of Frame size R0. Layout of the external control connection terminals is identical in frames R1...R2 but the location of the control board with the terminals is different in frames R3.

R0...R2

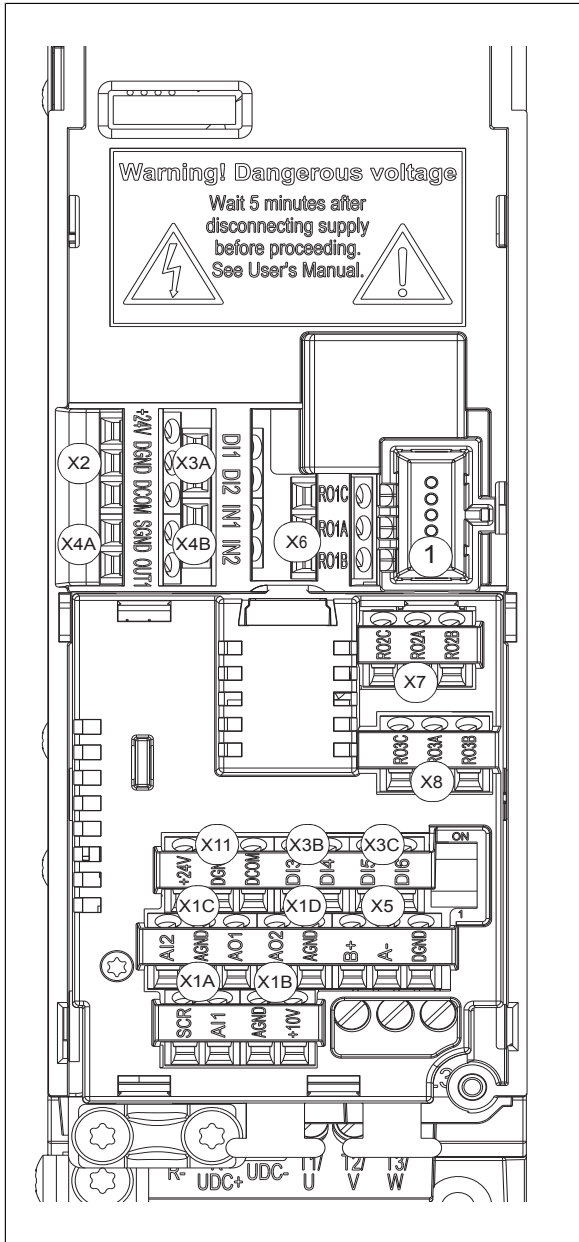

	Description
X1 A...D	Analog input and output
X2	Auxiliary voltage output
X3 A...C	Digital signal input
X4 A...B	Safety torque cancellation
X5	Modbus built-in fieldbus
X6...X8	Relay 1 output
X11	+24V DC voltage output
1	The interface is used for CCA-01 adapter configuration

■ External control connecting terminal, Frame size R3...R5

The figure below explains the external control connecting terminal layout of Frame size R3.

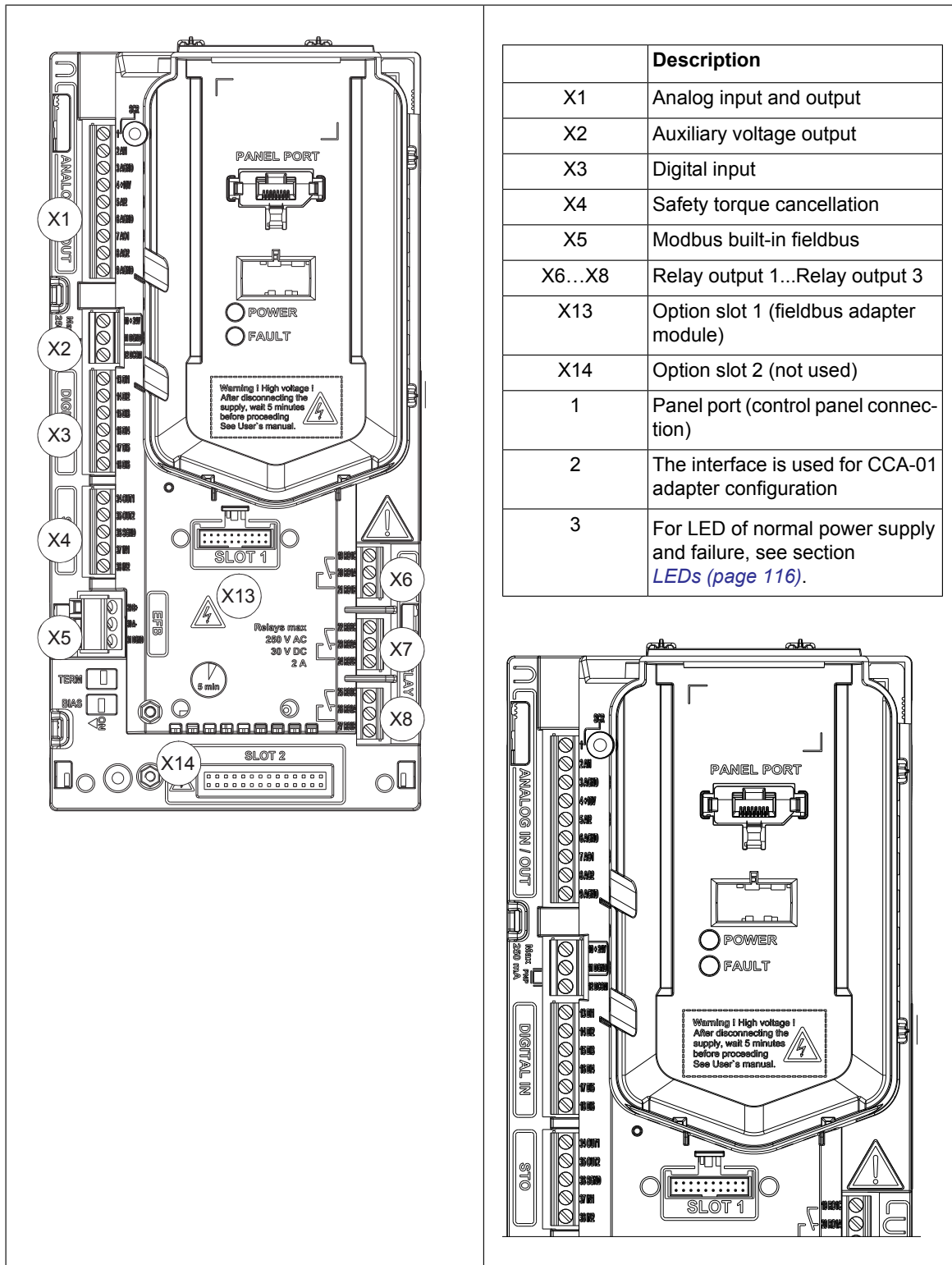

■ External control connection terminals, frames R6...R8

The layout of the external control connection terminals of frames R6...R8 is shown below.

	Description
X1	Analog input and output
X2	Auxiliary voltage output
X3	Digital input
X4	Safety torque cancellation
X5	Modbus built-in fieldbus
X6...X8	Relay output 1...Relay output 3
X13	Option slot 1 (fieldbus adapter module)
X14	Option slot 2 (not used)
1	Panel port (control panel connection)
2	The interface is used for CCA-01 adapter configuration
3	For LED of normal power supply and failure, see section LEDs (page 116) .



WARNING!

Do not connect the +24 V AC cable to the control board ground when the control board is powered using an external 24 V AC supply.

Mounted options

For information on mounted optional modules, see [Option modules \(page 99\)](#):

Control panel

The drive supports these control panels:

- ACS-AP-S
- ACS-AP-I
- ACS-AP-W
- ACS-BP-S
- RDUM-01 blank panel with RJ-45 connector.

For information on RDUM-01 blank panel, see [RDUM-01 blank control panel \(page 189\)](#).

For information on assistant and basic control control panel, see [ACS-AP-X assistant control panels user's manual \(3AUA0000085685 \[English\]\)](#) / [ACS-BP-S basic control panel's user's manual \(3AXD50000032527 \[English\]\)](#).

To remove the control panel, press the retaining clip at the top (1a) and pull it forward from the top edge (1b).

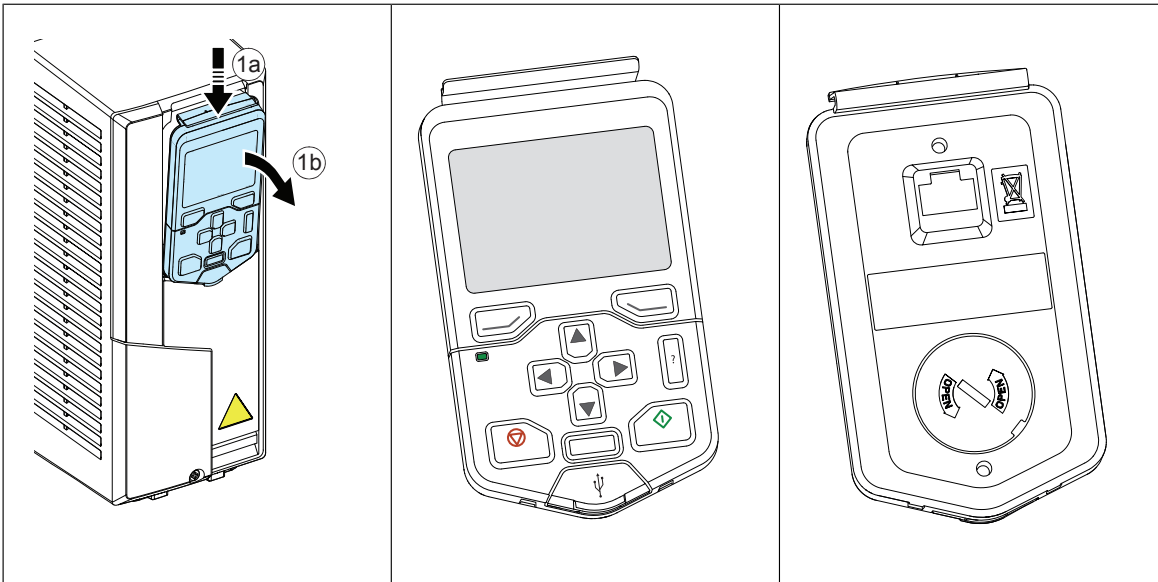

To reinstall the control panel, put the bottom of the container in position (1a), press the retaining clip at the top (1b) and push the control panel in at the top edge (1c).

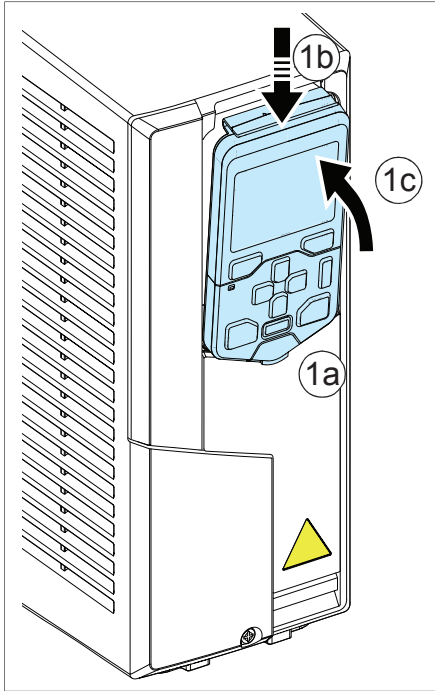

Type designation label

The type designation label includes IEC ratings, appropriate markings and the type designation and serial number, which allow identification of each drive. The type designation label is located on the left side of the drive, see section [Layout \(page 28\)](#). An example label is shown below.

ACS560-01-033A-4 S/N: 9173100580 SW V2.02.0.1										
ABB ¹ MADE IN INDIA ABB India Limited.	ACS560-01-033A-4 Input U1 3~ 380/480 VAC I1 32/27 A f1 50 Hz Output U2 3~ 0...U1 I2 32/27 A f2 0...500 Hz	⁵ RoHS CE ⁶ S/N: 9173100580								
<table border="1" style="border-collapse: collapse; width: 50px; height: 30px;"> <tr><td style="text-align: center; font-size: 8px;">FRAME</td></tr> <tr><td style="text-align: center; font-size: 24px; font-weight: bold;">R3</td></tr> </table> ² Air cooling IP20 ³ Icc 100 kA	FRAME	R3	<table border="0" style="width: 100%;"> <tr> <td style="width: 50%;">U1 3~ 380/480 VAC</td> <td style="width: 50%;">ACS560-01-033A-4</td> </tr> <tr> <td>I2 32/27 A</td> <td></td> </tr> <tr> <td>Pn 15 kW/20 hp</td> <td>S/N: 9173100580</td> </tr> </table>	U1 3~ 380/480 VAC	ACS560-01-033A-4	I2 32/27 A		Pn 15 kW/20 hp	S/N: 9173100580	
FRAME										
R3										
U1 3~ 380/480 VAC	ACS560-01-033A-4									
I2 32/27 A										
Pn 15 kW/20 hp	S/N: 9173100580									





No.	Description
1	Type designation, see section Type designation key (page 39) .
2	Frame (size)
3	Degree of protection

38 Operation principle and hardware description

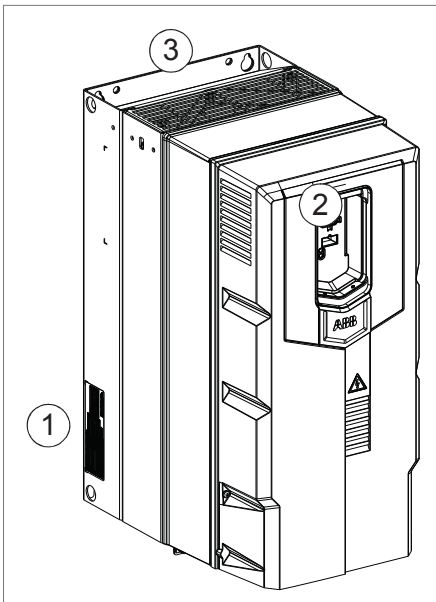
No.	Description
4	Nominal ratings in the supply voltage range, see section <i>Ratings (page 119)</i> , section <i>Electrical power network specification (page 132)</i> and section <i>Motor connection data (page 132)</i> . Input voltage range 3~ 380...480V AC. This is indicated in the type designation label as typical input voltage levels (U1) (3~ 400/480V AC).
5	Valid markings
6	S/N: Serial number of format MYYWWXXXX, where M: Manufacturer YY: 16, 17, 18, ... for 2016, 2017, 2018, ... WW: 01, 02, 03, ... for week 1, week 2, week 3, ... XXXXX: Integer starting every week from 0001

■ Locations of the labels on the drive



1	 <p>MADE IN INDIA ABB India Limited.</p> <div style="border: 1px solid black; padding: 2px; display: inline-block;"> FRAME R3 </div> <p>Air cooling IP20 Icc 100 kA</p>	<p>ACS560-01-033A-4</p> <table> <tr> <td>Input</td> <td>U1 3~ 380/480 VAC</td> </tr> <tr> <td></td> <td>I1 32/27 A</td> </tr> <tr> <td></td> <td>f1 50 Hz</td> </tr> <tr> <td>Output</td> <td>U2 3~ 0...U1</td> </tr> <tr> <td></td> <td>I2 32/27 A</td> </tr> <tr> <td></td> <td>f2 0...500 Hz</td> </tr> </table>	Input	U1 3~ 380/480 VAC		I1 32/27 A		f1 50 Hz	Output	U2 3~ 0...U1		I2 32/27 A		f2 0...500 Hz	<p>RoHS</p>    <p>S/N: 9173100580</p>
Input	U1 3~ 380/480 VAC														
	I1 32/27 A														
	f1 50 Hz														
Output	U2 3~ 0...U1														
	I2 32/27 A														
	f2 0...500 Hz														
	<p>U1 3~ 380/480 VAC I2 32/27 A Pn 15 kW/20 hp</p>	<p>ACS560-01-033A-4</p>  <p>S/N: 9173100580</p>													

2	ACS560-01-033A-4 S/N: 9173100580 SW V2.02.0.1
3	ACS560-01-033A-4  S/N: 9173100580

Type designation key

The type designation contains information on the specifications and configuration of the drive. You can find the type designation on the type designation label attached to the drive. The first digits from the left express the basic configuration, for example, ACS560-01-033A-4. The optional selections are given after that, separated by plus signs, for example, +K457. The main selections are described below. Not all selections are available for all types.

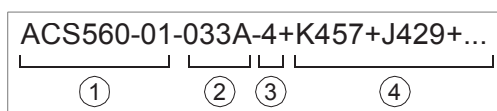

	CODE	DESCRIPTION
	Basic codes	
①	ACS560	Product series
	01	If no additional options are selected, adopt wall-mounted installation, IP20, basic control panel, reactor (R3~R8), EMC C3 filter (built-in EMC filter), safety torque cancellation, built-in brake chopper in Frame size R0, R1, R2 and R3, enhanced coating circuit board, cable access from the bottom, junction box or wiring plate and quick installation and start-up guide in multilingual language.
②	Size	
	xxxx	Refer to Ratings .
③	Voltage rating	
	4	380...480 V
④	Option codes (plus codes)	
	Control panel and panel options	
	J400	ACS-AP-S Assistant control panel
	J425	ACS-AP-I Assistant control panel
	J429	ACS-AP-W Assistant control panel with a bluetooth interface
	J424	RDUM-01 Blank control panel cover (no control panel)
	I/O	
	L515	BIO-01 I/O extension module (front option, can be used with fieldbus)

40 Operation principle and hardware description

	CODE	DESCRIPTION
	L534	BAPO-01 External 24 V DC (side option)
	L523	CMOD-02 External 24 V AC/DC (only for external power, I/O extensions not applicable)
	Fieldbus adapters	
	K454	FPBA-01 PROFIBUS DP
	K457	FCAN-01 CANopen
	K473	FENA-11 Ethernet (EtherNet/IP™, Modbus/TCP, PROFINET)
	K469	FECA-01 EtherCAT
	K458	FSCA-01 Modbus/RTU
	K475	FENA-21 2-port Ethernet (EtherNet/IP™, Modbus/TCP, PROFINET)
	Cables	
	J431	BCBL-01 USB to RJ45 PC connectivity cable (RS485)
	Full set of printed manuals in selected language.	
	R700	English
	X	Hindi

3AXD50000044998

4

Mechanical installation

Contents of this chapter

The chapter tells how to check the installation site, unpack, check the delivery and install the drive mechanically.

■ Safety

**WARNING!**

- Frames R5...R8: Lift the drive with a lifting device. Use the lifting eyes of the drive. Do not tilt the drive. **The drive is heavy and its center of gravity is high. An overturning drive can cause physical injury.**

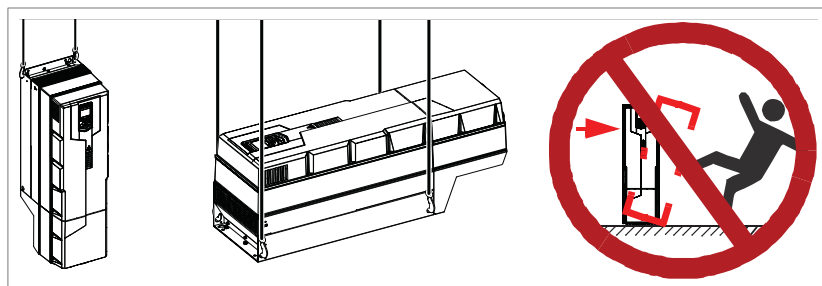

- Do not install the drive upside down. This can cause damage to the equipment.
-



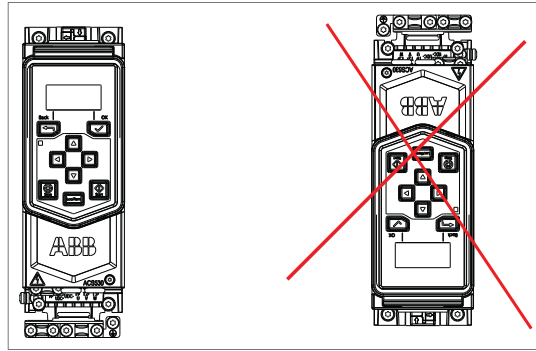

Checking the installation site

The drive must be placed in a cabinet and installed on the wall. Drives of frame sizes R0...R2 have two installation method as follows:

- Vertically alone

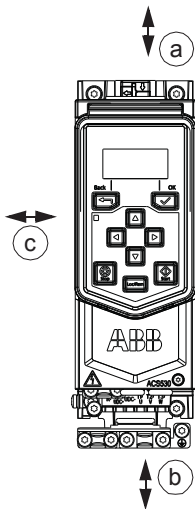

Frame Size	Vertical installation Free space					
	Above (a)		Below (b)		Beside (c)	
	mm	in	mm	in	mm	in
R0	30	1.2	200	7.9	150	5.9
R1	30	1.2	200	7.9	150	5.9
R2	30	1.2	200	7.9	150	5.9
R3	53	2.1	200	7.9	150	5.9
R4	53	2.1	200	7.9	150	5.9
R6	155	6.1	300	11.8	150	5.9
R7	155	6.1	300	11.8	150	5.9
R8	155	6.1	300	11.8	150	5.9

- Vertically side by side

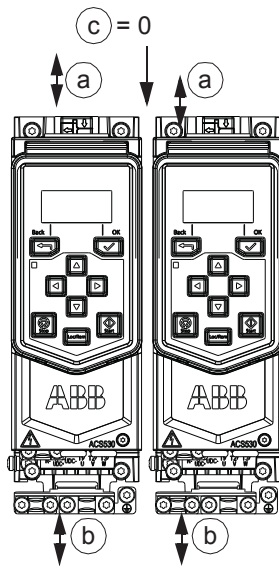

Frame Size	Vertical installation side by side - Free space					
	Above (a)		Below (b)		Between (c)	
	mm	in	mm	in	mm	in
R0	75	3	75	3	0	0
R1	75	3	75	3	0	0
R2	75	3	75	3	0	0
R3	200	7.9	200	7.9	0	0
R4	200	7.9	200	7.9	0	0
R5	200	7.9	200	11.8	0	0
R6	200	7.9	300	11.8	0	0
R7	200	7.9	300	11.8	0	0
R8	200	7.9	300	11.8	0	0
R8	200	7.9	300	11.8	0	0

3AXD10000561047.xls A

Check the installation site according to the requirements below:

- The installation site is sufficiently ventilated or cooled to remove heat from the drives. See section [Thermal losses, cooling data and noise \(page 129\)](#).
- The operation conditions of the drive meet the specifications given in section [Ambient conditions \(page 139\)](#).
- The wall is as close to vertical as possible, of non-flammable material and strong enough to carry the weight of the drive, see section [Circuit breakers \(page 127\)](#).
- The floor/material below the installation is non-flammable.
- There is enough free space above and below the drive to enable cooling air flow, service and maintenance, See the required free space tables for each of the different mounting alignments in [Checking the installation site \(page 42\)](#) (or [Dimensions, weights and free space requirements \(page 128\)](#)).

Required tools

To install the drive mechanically, you need the following tools:

- Drill with suitable bits.
- Screwdriver and/or wrench with a set of suitable bits (as appropriate for the installation hardware used).
- Tape measure, if you are not using the provided mounting template.

Moving the drive

Frames R5...R8: Move the transport package by pallet truck to the installation site.

Unpacking and examining delivery, frames R0...R2

The figure below shows the drive package and its contents. Make sure that all items are present and there are no signs of damage. Read the data on the type designation label of the drive to make sure that the drive is of the correct type. See section [Type designation label \(page 37\)](#).

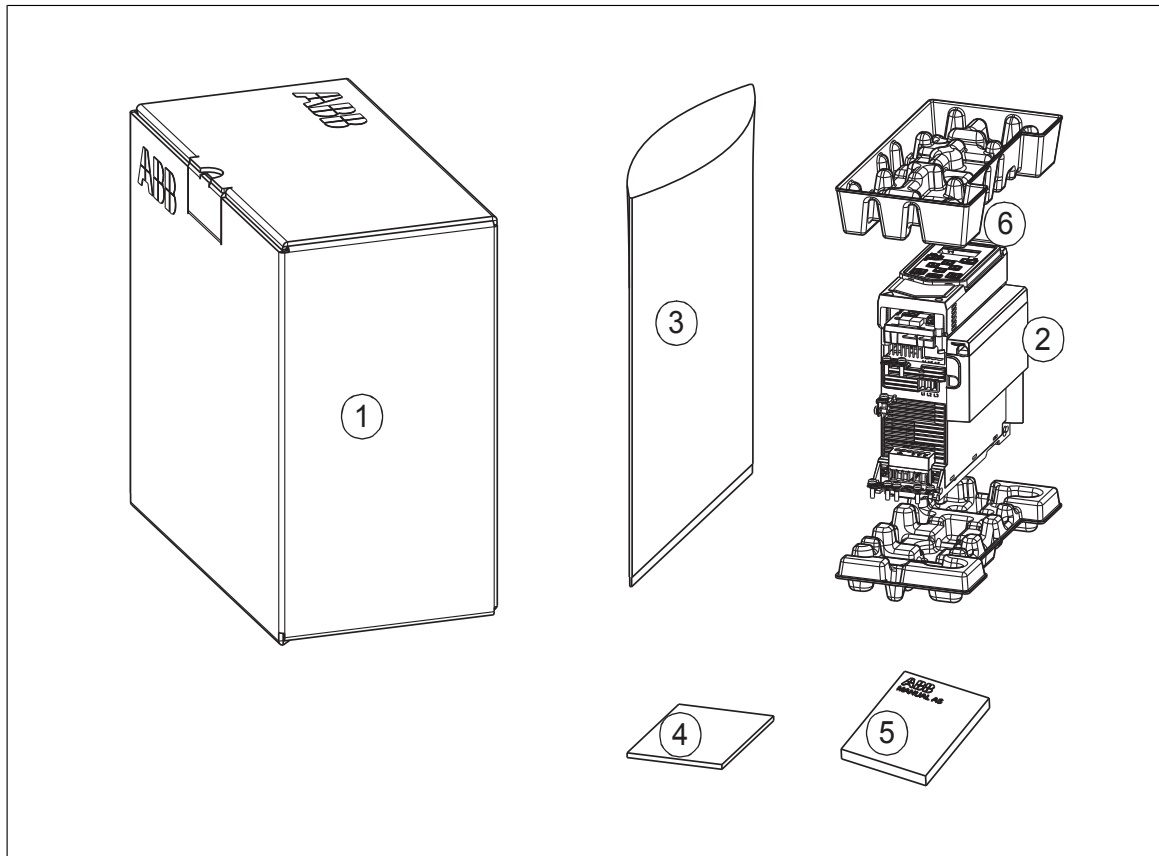

1	Drive transport package	4	Multi-language quick Installation and startup guide
2	Drive body (the figure shows frame size R1)	5	User manual (if any, adopt additional code for ordering)
3	Installation accessories of plastic bag are below the drive cover plate	6	Basic panel (provided as default panel)

Unpacking and examining delivery, frames R3...R4

The figure below shows the drive package and its contents. Make sure that all items are present and there are no signs of damage. Read the data on the type designation label of the drive to make sure that the drive is of the correct type. See section [Type designation label \(page 37\)](#).

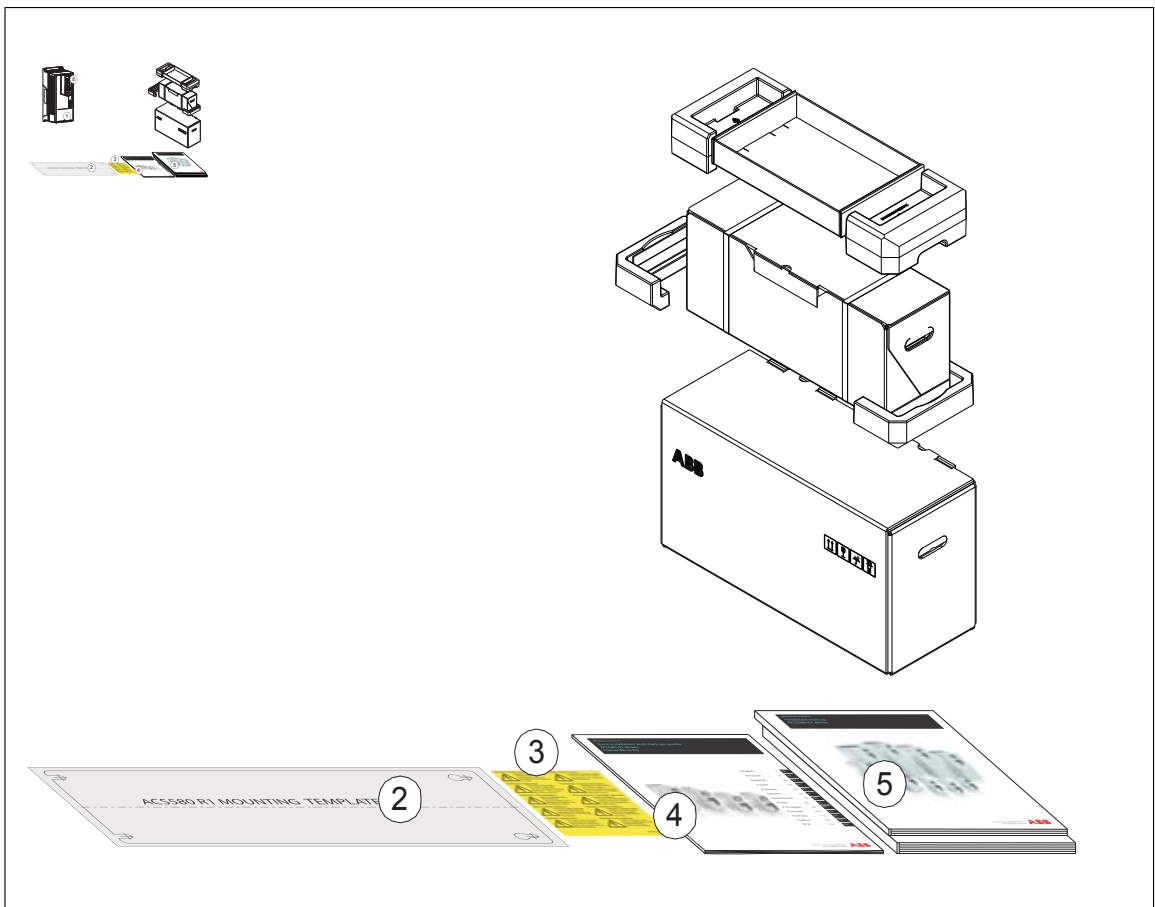

1	Drive body (the figure shows Frame size R3)	5	User manual (if any, adopt additional code for ordering)
2	Installation framework	6	Basic panel (provided as default panel)
3	Multi-language warning label of residual voltage		
4	Multi - language quick Installation and startup guide		

Unpacking and examining delivery, frames R5

The figure below shows the layout of the transport package. Examine that all items are present and there are no signs of damage. Read the data on the type designation label of the drive to make sure that the drive is of the correct type. See section [Type designation label \(page 37\)](#).

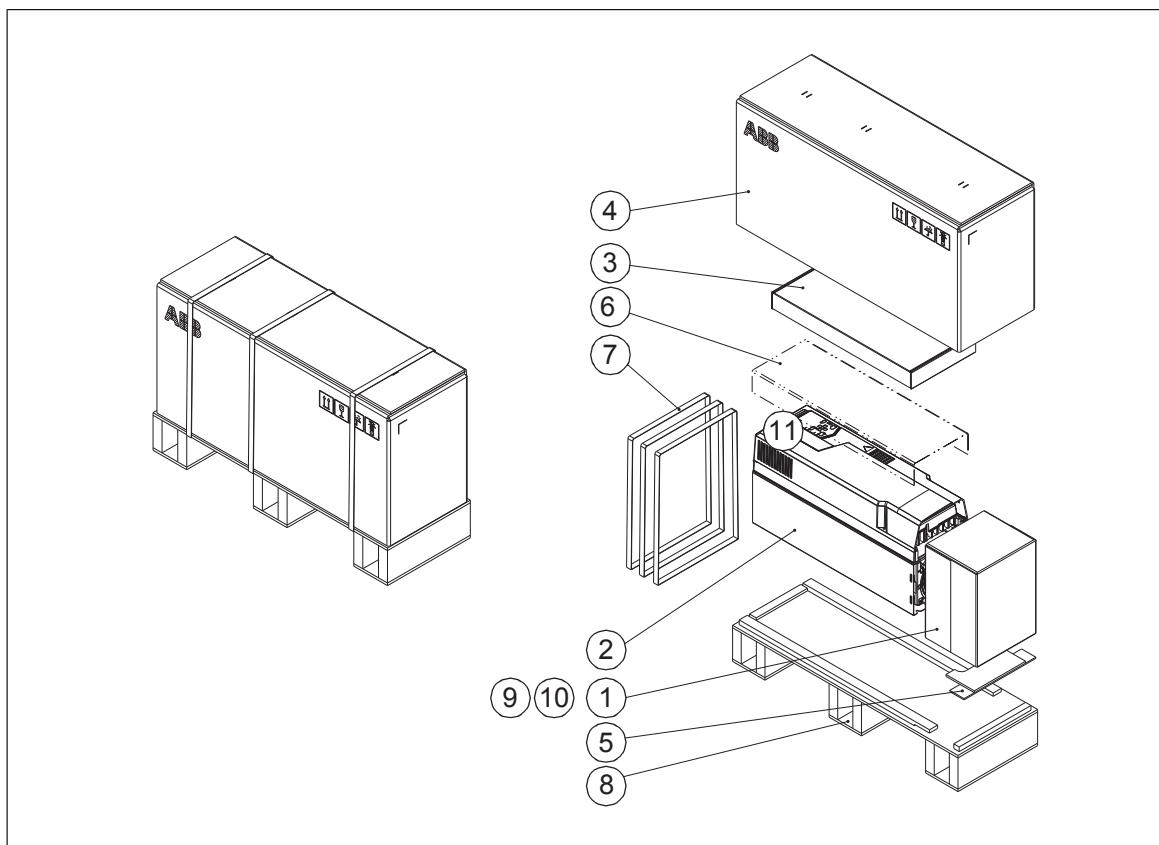

1	Cable box package.	5	Stopper
2	Drive	6	Cover protecting film
3	In the option box <ul style="list-style-type: none"> • Multilingual quick installation and start-up guide • User's manual (if ordered with a plus code) • Multilingual residual voltage warning stickers 	7	Straps
4	Cardboard box. Mounting template in the cardboard box.	8	Pallet
		9	Control panel selected in the order (in a separate package) in the option box
		10	Possible options in separate packages, if they have been ordered with a plus code, such as for example +K457 (FCAN-01 CANopen adapter module) in the option box.
		11	Basic panel (provided as default panel)

Unpacking and examining delivery, frames R6...R8

The figure below shows the layout of the transport package. Examine that all items are present and there are no signs of damage. Read the data on the type designation label of the drive to make sure that the drive is of the correct type. See section [Type designation label \(page 37\)](#).

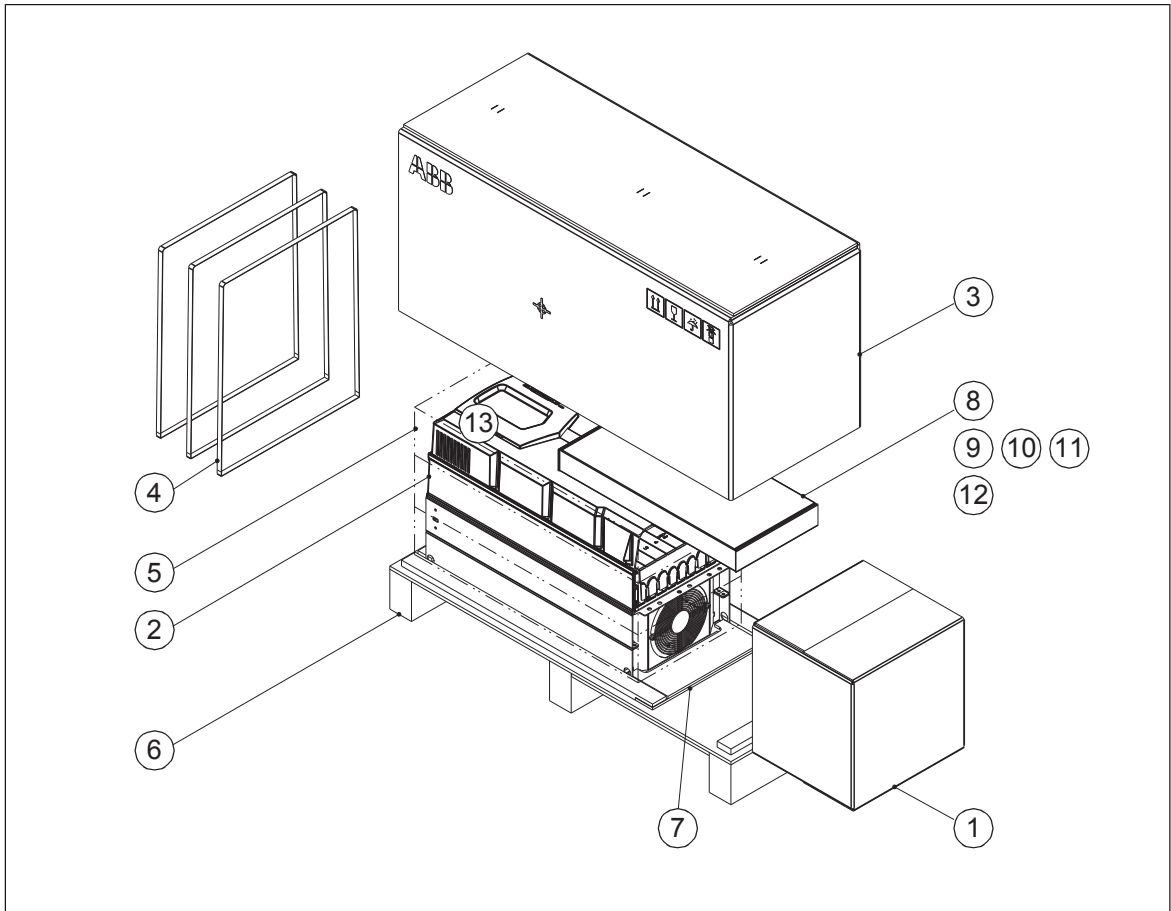

1	Cable box. Power and control cable grounding shelves in a plastic bag, assembly drawing.	9	In the option tray <ul style="list-style-type: none"> • Multilingual quick installation and startup guide • User's manual (if ordered with a plus code) • Residual voltage warning stickers
2	Drive with factory installed options.	10	Control panel selected in the order (in a separate package) in the option tray
3	Cardboard box	11	Possible options in separate packages, if they have been ordered with a plus code
4	Straps	12	Mounting template on top of the option tray
5	VCI bag for protecting against corrosion	13	Basic panel (provided as default panel)
6	Pallet		
7	Stopper		
8	Option tray		

To unpack:

- Cut the straps (4).
- Remove the cardboard box (3) and option tray (8).
- Remove the VCI bag (5).
- Attach lifting hooks to the lifting eyes of the drive (see the figure in [Contents of this chapter \(page 41\)](#)). Lift the drive with a hoist.



Installing the drive

■ Installing the drive vertically, frames size R0...R2

The figures show frame R0 as an example.

1. Mark the hole locations with the mounting template included in the package. Do not leave the mounting template behind the drive. The drive dimensions and hole locations are also shown in the drawings, see chapter [Dimension drawings \(page 145\)](#).

Note:

You can also adopt guide rail installation.

2. Drill the mounting holes.
3. Insert anchors or plugs into the holes and start the screws or bolts into the anchors or plugs.

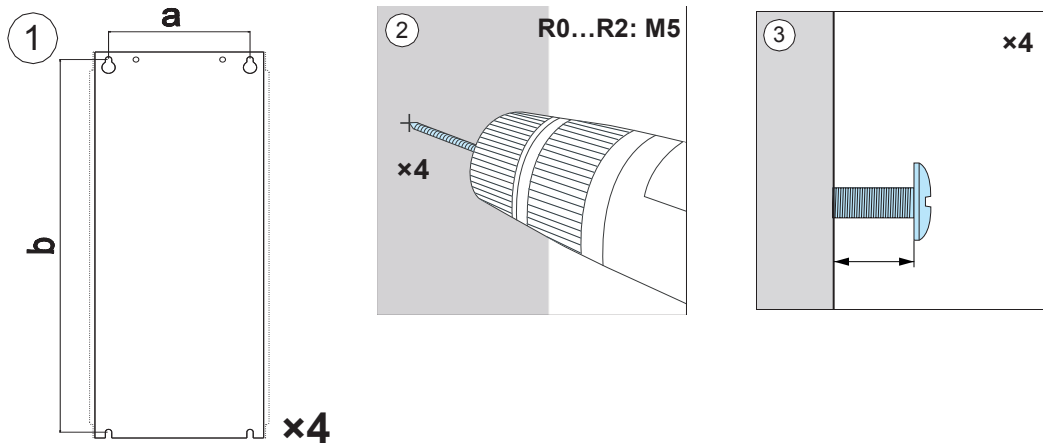

	R0		R1		R2	
	mm	in	mm	in	mm	in
a	50	1.97	75	2.95	148	5.83
b	191	7.52	191	7.52	191	7.52
Weight	kg	lb	kg	lb	kg	lb
	1.6	3.5	1.9	4.2	2.9	6.4

- Position the drive onto the screws on the wall. Tighten the screws in the wall securely.

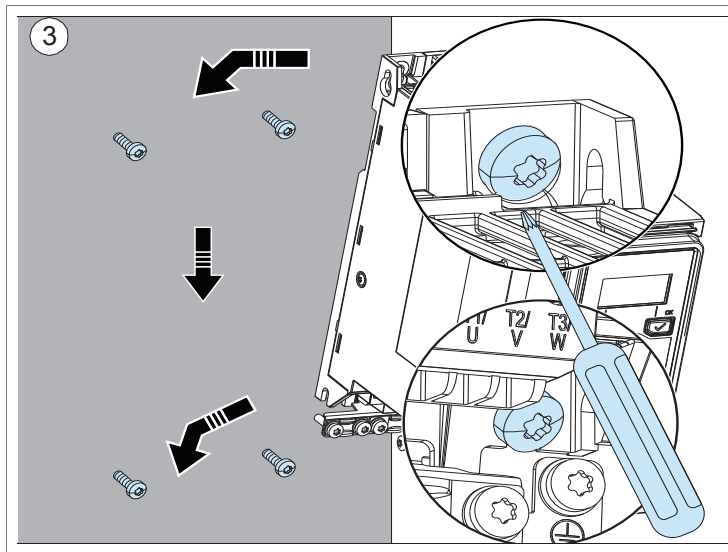

■ Installing the drive vertically, frame size R3...R4

- Mark the hole locations with the mounting template included in the package. Do not leave the mounting template behind the drive. The drive dimensions and hole locations are also shown in the drawings, see chapter *Dimension drawings (page 145)*.
- Drill the mounting holes.
- Start the screws or bolts into the mounting holes.

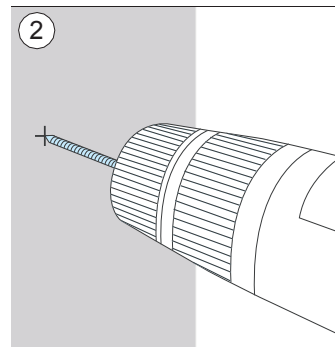
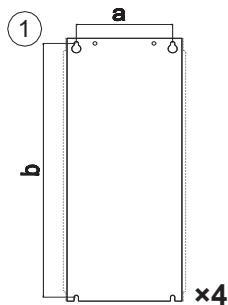

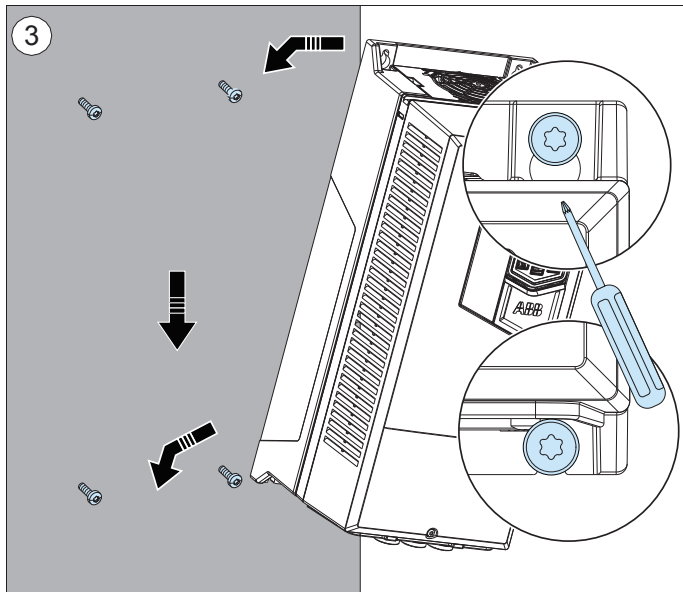

	R3		R4	
	mm	in	mm	in
a	160	6.30	160	6.30
b	473	18.62	619	24.37
Weight	kg	lb	kg	lb
△	14.9	32.84	19.0	41.89

■ **Installing the drive vertically, frames size R5...R8**

1. Mark the punch positions for the six mounting holes with the mounting template included in the package. Do not leave the mounting template under the drive.
The drive dimensions and hole locations are also shown in the drawings, see chapter *Dimension drawings (page 145)*.

Note:

You can use only two screws instead of four to attach the lower part of the drive

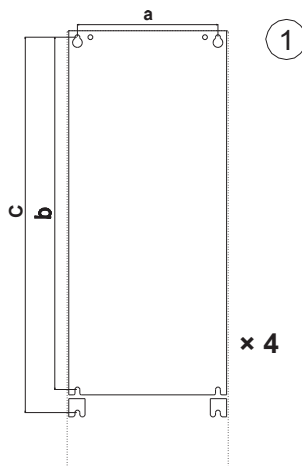

	R5		R6		R7		R8	
	mm	in	mm	in	mm	in	mm	in
a	160	6.3	213	8.4	245	9.7	263	10.4
b	581	22.9	531	20.9	583	22.9	658	25.9
c	612	24.1	571	22.5	623	24.5	701	27.6
d	300	11.8	300	11.8	300	11.8	300	11.8
e	200	7.9	200	7.9	200	7.9	200	7.9
	kg	lb	kg	lb	kg	lb	kg	lb
△	28	62	45	99	55	121	70	154

2. Drill the mounting holes.
3. Start the screws or bolts into the mounting holes.
4. Position the drive onto the screws on the wall. Lift the drive with another person as it is heavy.
5. Tighten the screws in the wall securely.

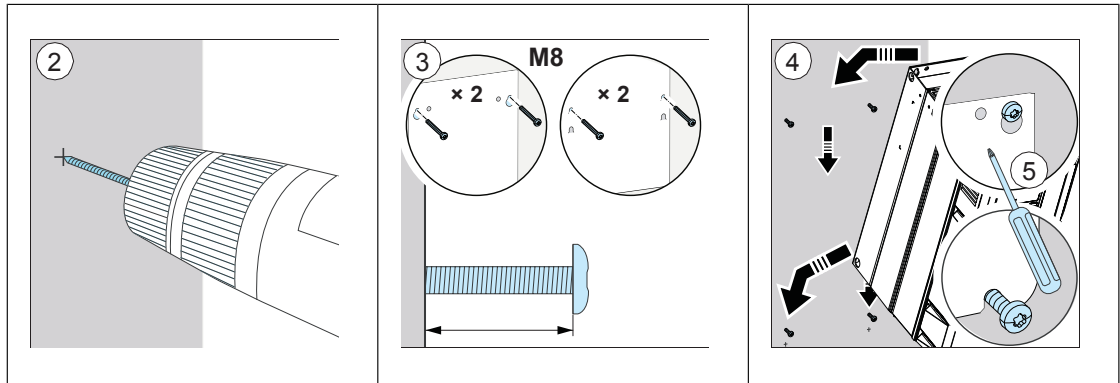

6. Remove the front cover as follows:
 - Remove the fastening screws (a).
 - Move the cover to the top side and then up

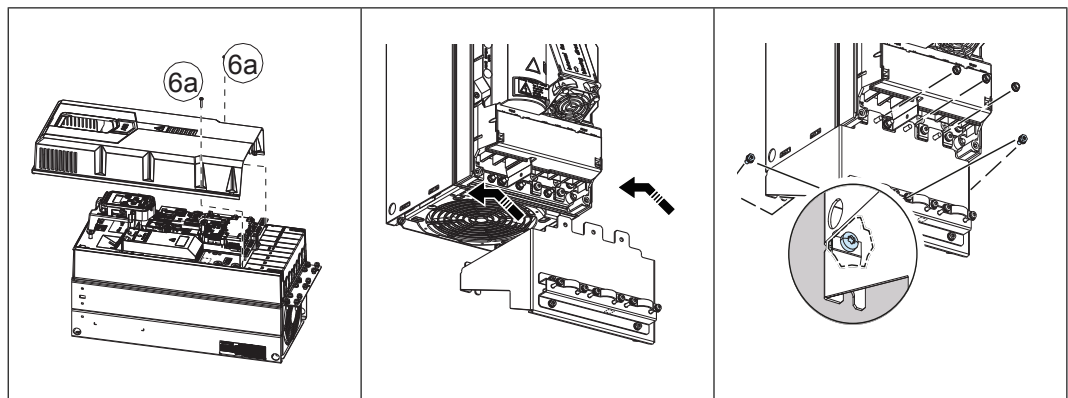

■ Installing the drive vertically side by side

Install the drive following the steps in the appropriate section [Installing the drive vertically, frames size R0...R2 \(page 48\)](#), [Installing the drive vertically, frame size R3...R4 \(page 49\)](#) or [Installing the drive vertically, frames size R5...R8 \(page 50\)](#).

■ Installing the drive horizontally side by side

Install the drive following the steps in the appropriate section [Installing the drive vertically, frames size R0...R2 \(page 48\)](#), [Installing the drive vertically, frame size R3...R4 \(page 49\)](#) or [Installing the drive vertically, frames size R5...R8 \(page 50\)](#).



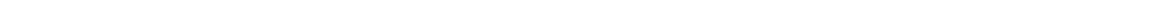

5

Planning the electrical installation

Contents of this chapter

This chapter contains instructions for planning the electrical installation of the drive, for example, for checking the compatibility of the motor and drive, selecting cables, protections, and cable routing.

Note:

The installation must always be designed and made according to applicable local laws and regulations. The manufacturer does not assume any liability whatsoever for any installation which breaches the local laws and/or other regulations. Furthermore, if the recommendations given by the manufacturer are not followed, the drive may experience problems that the warranty does not cover.

Selecting the supply disconnecting device

Install a hand-operated input disconnecting device between the AC power source and the drive. The disconnecting device must be of a type that can be locked to the open position for installation and maintenance work.

■ European Union

To meet the European Union Directives, according to standard EN 60204-1, *Safety of Machinery*, the disconnecting device must be one of the following types:

- switch-disconnector of utilization category AC-23B (EN 60947-3)
 - disconnector that has an auxiliary contact that in all cases causes switching devices to break the load circuit before the opening of the main contacts of the disconnector (EN 60947-3)
 - circuit breaker suitable for isolation in accordance with EN 60947-2.
-

■ Other regions

The disconnecting device must conform to the applicable local safety regulations.

Checking the compatibility of the motor and drive

Use an asynchronous AC induction motor with the drive. Several induction motors can be connected to the drive at a time. Check that the motor and the drive are compatible according to the rating table in section [Ratings \(page 119\)](#). The table lists the typical motor power for each drive type.

Selecting the power cables

■ General rules

Select the input power and motor cables **according to local regulations:**

- The input power and the motor cables must be able to carry the corresponding load currents. See section [Ratings \(page 119\)](#) for the rated currents.
- The cable must be rated for at least 70 °C maximum permissible temperature of conductor in continuous use. For US, see [Conduit \(page 57\)](#).
- The conductivity of the PE conductor must be sufficient, see the table below.
- 600 V AC cable is accepted for up to 500 V AC.

To comply with the EMC requirements of the CE mark, use one of the approved cable types in section [Recommended power cable types \(page 56\)](#).

Symmetrical shielded cable reduces electromagnetic emission of the whole drive system as well as the stress on motor insulation, bearing currents and wear.

The protective conductor must always have an adequate conductivity. The table below shows the minimum cross-sectional area related to the phase conductor size according to IEC 61439-1 when the phase conductor and the protective conductor are made of the same metal.

Cross-sectional area of the phase conductors S (mm ²)	Minimum cross-sectional area of the corresponding protective conductor S _p (mm ²)
S ≤ 16	S
16 < S ≤ 35	16
35 < S	S/2

Note:

See the IEC/EN 61800-5-1 requirement on grounding in the Note on section [Grounding](#).

■ Typical power cable sizes

The table below gives copper cable types with concentric copper shield for the drives with nominal current. The value separated by the plus sign means the diameter of the PE conductor.

Drive type ACS560	Frame size	IEC ¹⁾		US	
		Cu cable type	Al cable type ²⁾	Cu cable type	Al cable type ³⁾
		mm ²	mm ²	AWG/kcmil	AWG/kcmil
3-phase U_N = 400 V (380...480 V)					
02A6-4	R0	3 x 1.5 + 1.5	-	16	-
03A3-4	R0	3 x 1.5 + 1.5	-	16	-
04A0-4	R0	3 x 1.5 + 1.5	-	16	-
05A6-4	R0	3 x 1.5 + 1.5	-	16	-
07A2-4	R0	3 x 1.5 + 1.5	-	16	-
09A4-4	R0	3 x 2.5 + 2.5	-	14	-
12A6-4	R1	3 x 2.5 + 2.5	-	14	-
017A-4	R2	3 x 2.5 + 2.5	-	14	-
025A-4	R2	3 x 6 + 6	-	10	-
033A-4	R3	3 x 10 + 10	-	8	-
039A-4	R3	3 x 10 + 10	-	8	-
046A-4	R3	3 x 16 + 16	-	6	-
062A-4	R4	3 x 25 + 16	3 x 35	4	-
073A-4	R4	3 x 35 + 16	3 x 50	2	-
088A-4	R5	3 x 35 + 16	3 x 70	2	-
106A-4	R5	3 x 50 + 25	3 x 70	1/0	-
145A-4	R6	3 x 95 + 50	3 x 120	3/0	-
169A-4	R7	3 x 120 + 70	3 x 150	250 MCM	-
206A-4	R7	3 x 150 + 70	3 x 240	300 MCM	-
246A-4	R8	2 x (3 x 70 + 35)	2 x (3 x 95)	2 x 2/0	-
293A-4	R8	2 x (3 x 95 + 50)	2 x (3 x 120)	2 x 3/0	-

1) The cable sizing is based on maximum parallel layout of 6 cables laid on a cable ladder side by side, ambient temperature 30 °C, PVC insulation, surface temperature 70 °C (EN 60204-1 and IEC 60364-5-52/2001). For other conditions, size the cables according to local safety regulations, appropriate input voltage and the load current of the drive. See also [Terminal and lead-through data for the power cables \(page 130\)](#) for the accepted cable sizes of the drive.

2) Aluminum cables must not be used with frames R0...R4.

3) In the USA, aluminum cables must not be used.

See also section [Terminal and lead-through data for the power cables \(page 130\)](#).



■ Alternative power cable types

The recommended and the not allowed power cable types to be used with the drive are presented below.

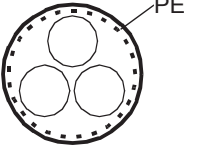
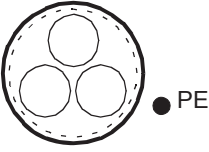
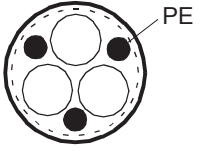
Recommended power cable types

	<p>Symmetrical shielded cable with three phase conductors and a concentric PE conductor as the shield. The shield must meet the requirements of IEC 61439-1, see General rules (page 54). Check with local/state/country electrical codes for allowance.</p>
	<p>Symmetrical shielded cable with three phase conductors and a concentric PE conductor as the shield. A separate PE conductor is required if the shield does not meet the requirements of IEC 61439-1, see General rules (page 54).</p>
	<p>Symmetrical shielded cable with three phase conductors and symmetrically constructed PE conductor, and a shield. The PE conductor must meet the requirements of IEC 61439-1, see General rules (page 54).</p>

Power cable types for limited use

	<p>A four-conductor system (three phase conductors and a protective conductor on a cable tray) is not allowed for motor cabling (it is allowed for input cabling).</p>
	<p>A four-conductor system (three phase conductors and a PE conductor in a PVC conduit) is allowed for input cabling with phase conductor cross-section less than 10 mm² (8 AWG) or motors ≤ 30 kW (40 hp). Not allowed in the USA.</p>
	<p>Corrugated or EMT cable with three phase conductors and a protective conductor is allowed for motor cabling with phase conductor cross section less than 10 mm² (8 AWG) or motors ≤ 30 kW (40 hp).</p>

Not allowed power cable types

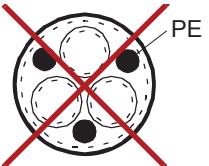
	<p>Symmetrical shielded cable with individual shields for each phase conductor is not allowed on any cable size for input or motor cabling.</p>
---	---

■ Motor cable shield

If the motor cable shield is used as the sole protective earth conductor of the motor, make sure that the conductivity of the shield is sufficient. See section [General rules \(page 54\)](#) above, or IEC 61439-1.

To effectively suppress radiated and conducted radio-frequency emissions, the cable shield conductivity must be at least 1/10 of the phase conductor conductivity. The requirements are easily met with a copper or aluminum shield. The minimum requirement of the motor cable shield of the drive is shown below. It consists of a concentric layer of copper wires with an open helix of copper tape or copper wire. The better and tighter the shield, the lower the emission level and bearing currents.

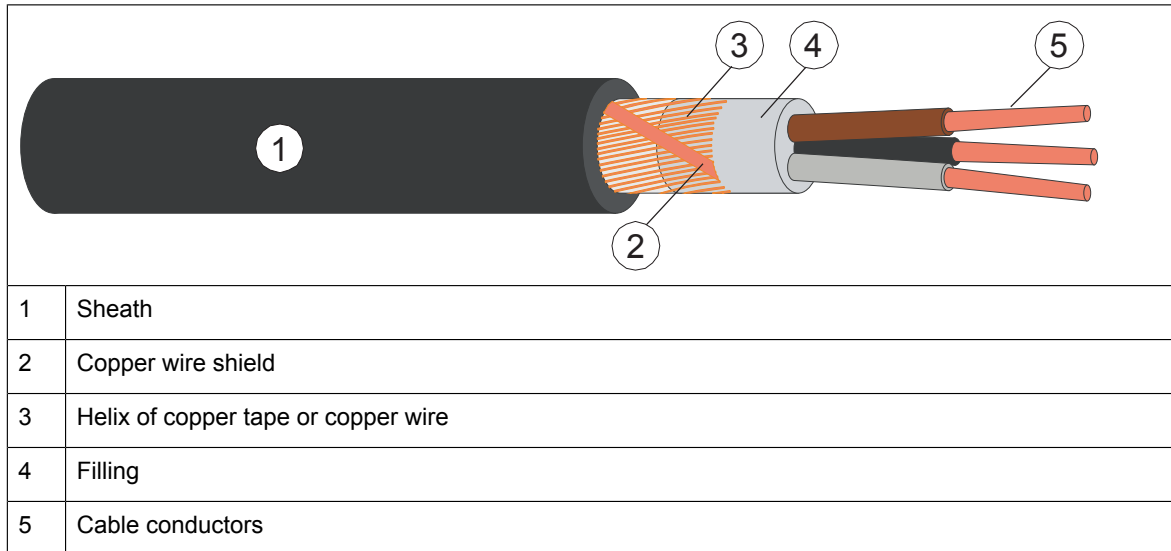

Conduit

Couple separate parts of a conduit together: bridge the joints with a ground conductor bonded to the conduit on each side of the joint. Also bond the conduits to the drive enclosure and motor frame. Use separate conduits for input power, motor, and control wiring. When conduit is employed, type MC continuous corrugated aluminum armor cable or shielded cable is not required. A dedicated ground cable is always required.

Note:

Do not run motor wiring from more than one drive in the same conduit.

Armored cable / shielded power cable

Six-conductor (three phases and three ground) type MC continuous corrugated aluminum armor cable with symmetrical grounds is available from the following suppliers (trade names in parentheses):

- Anixter Wire & Cable (Philsheath)
- BICC General Corp (Philsheath)
- Rockbestos Co. (Gardex)
- Oaknite (CLX).

Shielded power cables are available from the following suppliers:

- Belden
- LAPPKABEL (ÖLFLEX)
- Pirelli.

Selecting the control cables

■ Shielding

All control cables must be shielded.

Use a double-shielded twisted pair cable (figure a below) for analog signals. Employ one individually shielded pair for each signal. Do not use common return for different analog signals.

A double-shielded cable is the best alternative for low-voltage digital signals but single-shielded (b) twisted pair cable is also acceptable.

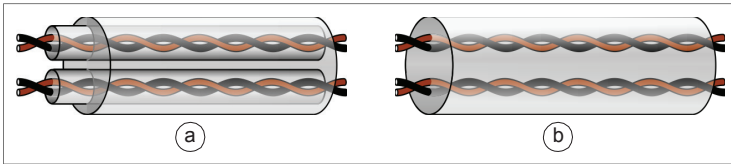

■ Signals in separate cables

Run analog and digital signals in separate, shielded cables. Do not mix 24 V AC/DC and 115/230 V AC signals in the same cable.

■ Signals allowed to be run in the same cable

If the voltage of relay control signal is 48V or below, the signal can be run in the same cables as digital input signals. The relay-controlled signals should be run as twisted pairs.

■ Relay cable

The cable type with braided metallic screen (for example ÖLFLEX by LAPPKABEL, Germany) is tested and approved by ABB.

■ Control panel cable

In remote use, the cable connecting the control panel to the drive must not exceed 100 m (330 ft). If multiple drives are connected, the total length of the panel bus must not exceed 100 m (330 ft).

The cable type tested and approved by ABB is used in control panel option kits. Suitable cables are CAT 5e unshielded or shielded twisted pair cables.

■ Drive composer PC tool cable

Use assistant control panel or RDUM-01 panel to connect the drive composer PC tool with the drive. Use USB type A (PC) - type B (control panel) cable for assistant control panel and BCBL-01 for RDUM-01 panel. The maximum length of the cable must not exceed 3 m (9.8 ft).

■ Routing the cables

General guidelines, IEC

- Route the motor cable away from other cables. Motor cables of several drives can be run in parallel installed next to each other.
- Install the motor cable, input power cable and control cables on separate trays.
- Avoid long parallel runs of motor cables with other cables in order to decrease electromagnetic interference caused by the rapid changes in the drive output voltage.
- Where control cables must cross power cables, make sure they are arranged at an angle as near to 90 degrees as possible.
- Do not run extra cables through the drive.
- Make sure that the cable trays have good electrical bonding to each other and to the grounding electrodes. Aluminum tray systems can be used to improve local equalizing of potential.

This figure illustrates the cable routing guidelines with an example drive.

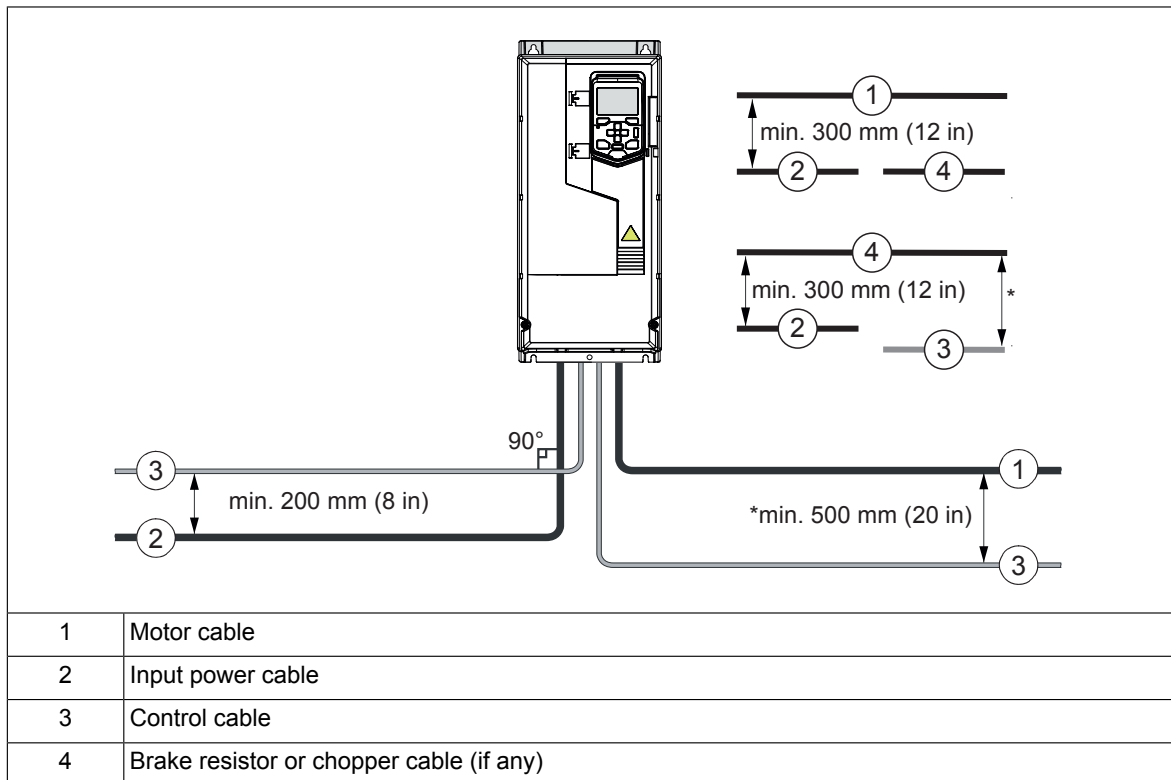

General guidelines, North America

The following illustrates general guidelines for routing power and motor cabling in conduit. Ensure the installation of your application is in accordance with national and local codes.

- Do not run input power cable and motor cable in the same conduit.
- Use separate conduit for each motor cable run.

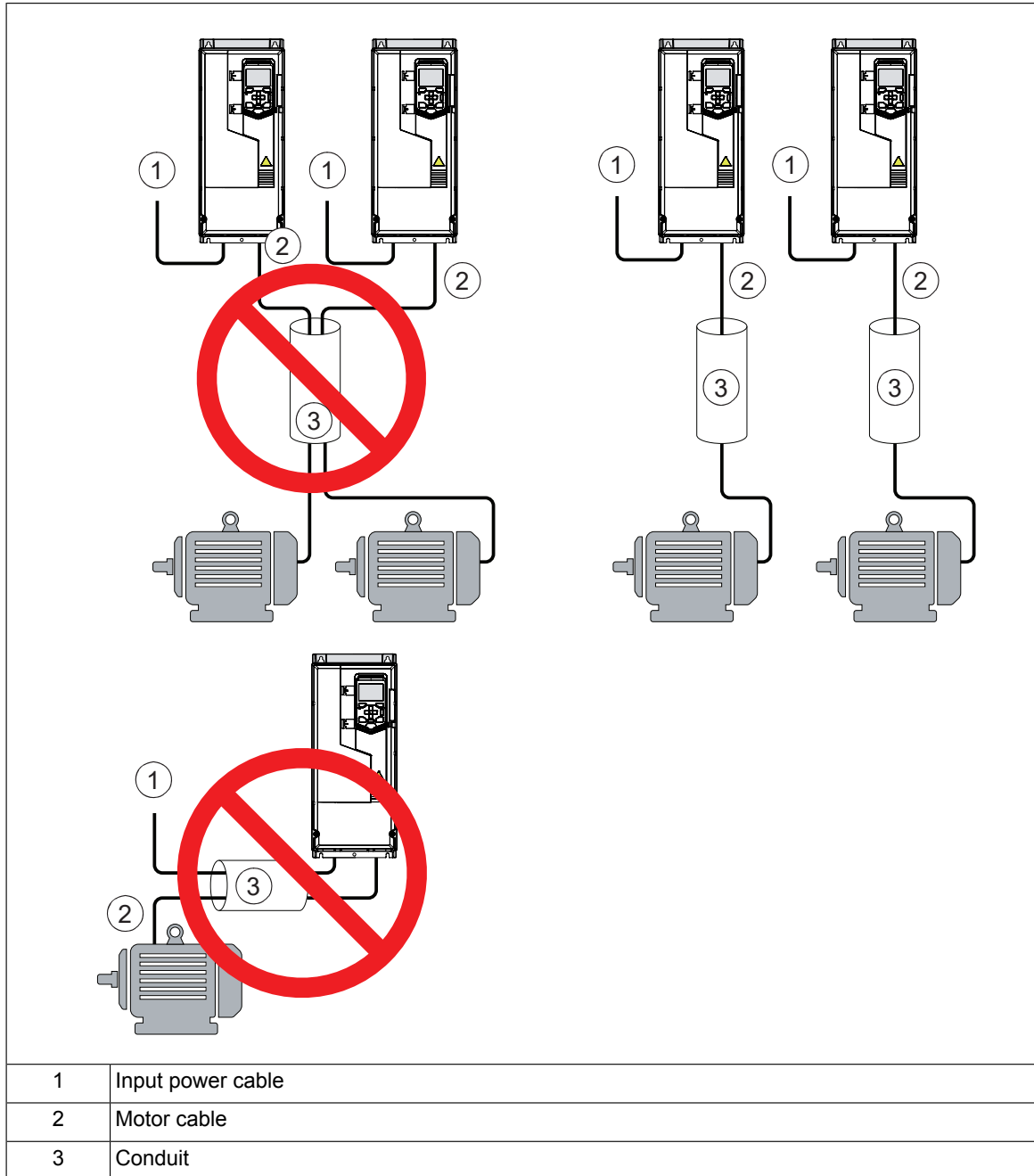

Continuous motor cable shield or enclosure for equipment on the motor cable

To minimize the emission level when safety switches, contactors, connection boxes or similar equipment are installed on the motor cable between the drive and the motor:

- Install the equipment in a metal enclosure.
- Use either a symmetrical shielded cable (preferred alternative), or install the cabling in a metal conduit.
- Make sure that there is a good and continuous galvanic connection in the shield/conduit between drive and motor.
- Connect the shield/conduit to the protective ground terminal of the drive and the motor.

Separate control cable ducts

Lead 24 V and 230 V (120 V) control cables in separate ducts unless the 24 V cable is insulated for 230 V (120 V) or insulated with an insulation sleeving for 230 V (120 V).

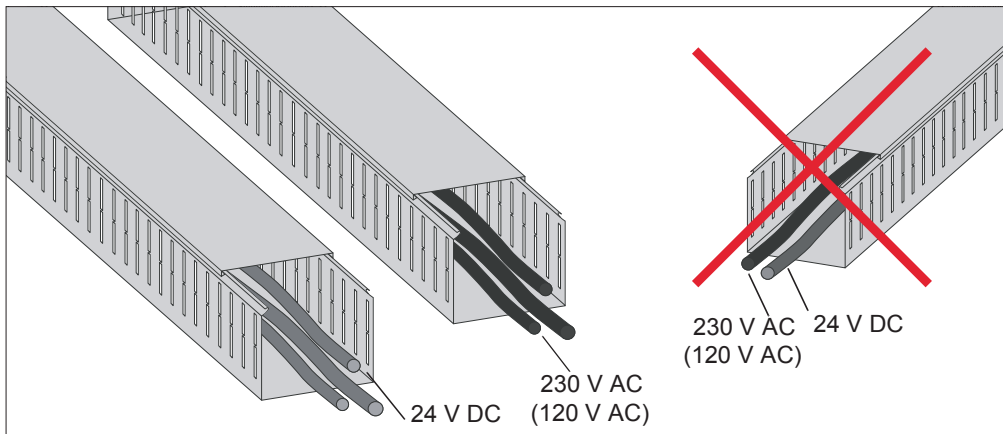

■ Implementing thermal overload and short-circuit protection

Protecting the input cabling and the drive upon a short-circuit

To protect the input cabling in short-circuit situations, install fuses or a suitable circuit breaker at the supply side of the cabling.

The drive is equipped with internal AC fuses as standard. In case of a short-circuit inside the drive, the AC fuses protect the drive, restrict drive damage, and prevent damage to adjoining equipment.

Protecting the motor and motor cable in short-circuits

The drive protects the motor cable and motor in a short-circuit situation when the motor cable is sized according to the nominal current of the drive. No additional protection devices are needed.

Protecting the drive and the power cables against thermal overload

The drive protects itself and the input and motor cables against thermal overload when the cables are sized according to the nominal current of the drive. No additional thermal protection devices are needed.



WARNING!

If the drive is connected to multiple motors, use a separate circuit breaker or fuses for protecting each motor cable and motor against overload. The drive overload

protection is tuned for the total motor load. It may not trip due to an overload in one motor circuit only.

Protecting the motor against thermal overload

According to regulations, the motor must be protected against thermal overload and the current must be switched off when overload is detected. The drive includes a motor thermal protection function that protects the motor and switches off the current when necessary. Depending on a drive parameter value, the function either monitors a calculated temperature value (based on a motor thermal model) or an actual temperature indication given by motor temperature sensors. The user can tune the thermal model further by feeding in additional motor and load data.

The most common temperature sensors are:

- motor sizes IEC180...225: thermal switch, eg. Klixon
- motor sizes IEC200...250 and larger: PTC or Pt100.

See the firmware manual for more information on the motor thermal protection function.

Protecting the drive against ground faults

The drive is equipped with an internal ground fault protective function to protect the unit against ground faults in the motor and motor cable. This is not a personnel safety or a fire protection feature. The ground fault protective function can be reduced with parameter 31.20 Earth fault..

■ Residual current device compatibility

The drive is suitable to be used with residual current devices of Type B.

Note:

The EMC filter of the drive includes capacitors connected between the main circuit and the frame. These capacitors and long motor cables increase the ground leakage current and may cause fault current circuit breakers to function.

■ Implementing the Emergency stop function

For safety reasons, install the emergency stop devices at each operator control station and at other operating stations where emergency stop may be needed. Design the emergency stop according to relevant standards.

Note:

Pressing the stop key  on the control panel of the drive does not generate an emergency stop of the motor or separate the drive from dangerous potential.

Implementing the Safe torque off function

See chapter [The Safe torque off function](#).

Implementing the undervoltage control (power-loss ride-through)

See *ACS560 standard control program firmware manual* (3AXD50000044997 [English]).

Using a contactor between the drive and the motor

Implementing the control of the output contactor depends on how you select the drive to operate. See also section [\(page 63\)](#).

When you have selected to use vector control mode and motor ramp stop, open the contactor as follows:

1. Give a stop command to the drive.
2. Wait until the drive decelerates the motor to zero speed.
3. Open the contactor.

When you have selected to use vector control mode and motor coast stop or scalar control mode, open the contactor as follows:

1. Give a stop command to the drive.
2. Open the contactor.



WARNING!

When the Vector control mode is in use, never open the output contactor while the drive controls the motor. The vector control operate extremely fast, much faster than it takes for the contactor to open its contacts. When the contactor starts opening while the drive controls the motor, the vector control will try to maintain the load current by immediately increasing the drive output voltage to the maximum. This will damage the contactor completely.

■ **Implementing a bypass connection**

If bypassing is required, employ mechanically or electrically interlocked contactors between the motor and the drive and between the motor and the power line. Make sure with interlocking that the contactors cannot be closed simultaneously. The installation must be clearly marked as defined in IEC/EN 61800-5-1, subclause 6.5.3, for example, "THIS MACHINE STARTS AUTOMATICALLY".



WARNING!

Never connect the drive output to the electrical power network. The connection may damage the drive.

■ **Example bypass connection**

An example bypass connection is shown below.

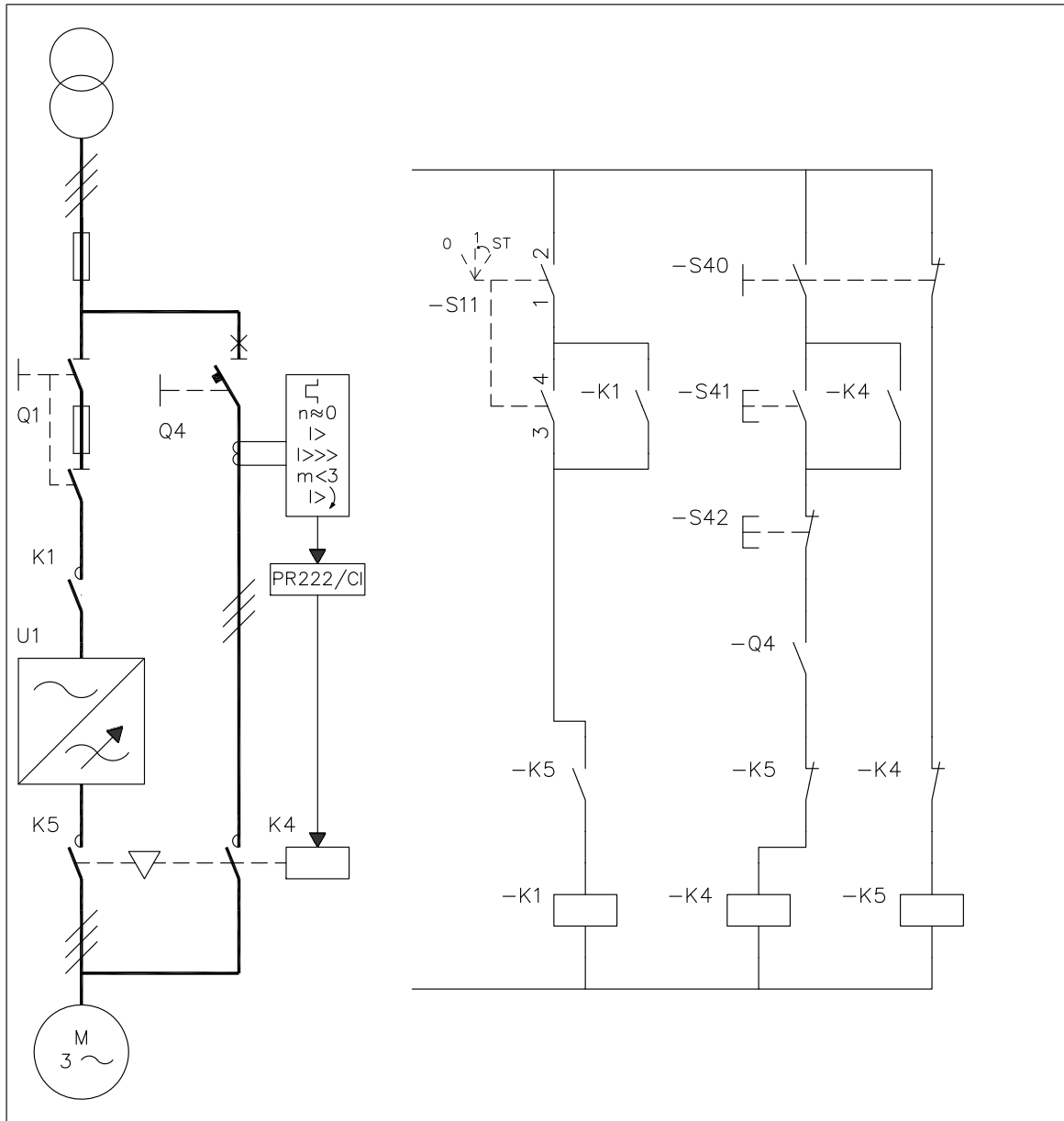

Q1	Main switch for the drive	S11	Drive main contactor on/off control
Q4	Bypass circuit breaker	S40	Motor power supply selection (drive or direct-on-line)
K1	Drive main contactor	S41	Start when the motor is connected direct-on-line
K4	Bypass contactor	S42	Stop when the motor is connected direct-on-line
K5	Drive output contactor	U1	Drive

Switching the motor power supply from drive to direct-on-line

1. Stop the drive and the motor with the drive control panel (drive in local control mode) or with the external stop signal (drive in remote control mode).
2. Open the main contactor of the drive with S11.
3. Switch the motor power supply from the drive to direct-on-line with S40.
4. Wait for 10 seconds to allow the motor magnetization to die away.
5. Start the motor with S41.

Switching the motor power supply from direct-on-line to drive

1. Stop the motor with S42.
2. Switch the motor power supply from direct-on-line to the drive with S40.
3. Close the main contactor of the drive with switch S11 (-> turn to position ST for two seconds and leave at position 1).
4. Start the drive and the motor with the drive control panel (drive in local control mode) or with the external start signal (drive in remote control mode).

Protecting the contacts of relay outputs

Inductive loads (relays, contactors, motors) cause voltage transients when switched off.

It is highly recommended that inductive loads are equipped with noise attenuating circuits (varistors, RC filters [AC] or diodes [DC]) in order to minimize the EMC emission at switch-off. If not suppressed, the disturbances may connect capacitively or inductively to other conductors in the control cable and form a risk of malfunction in other parts of the system.

Install the protective component as close to the inductive load as possible. Do not install protective components at the relay outputs.

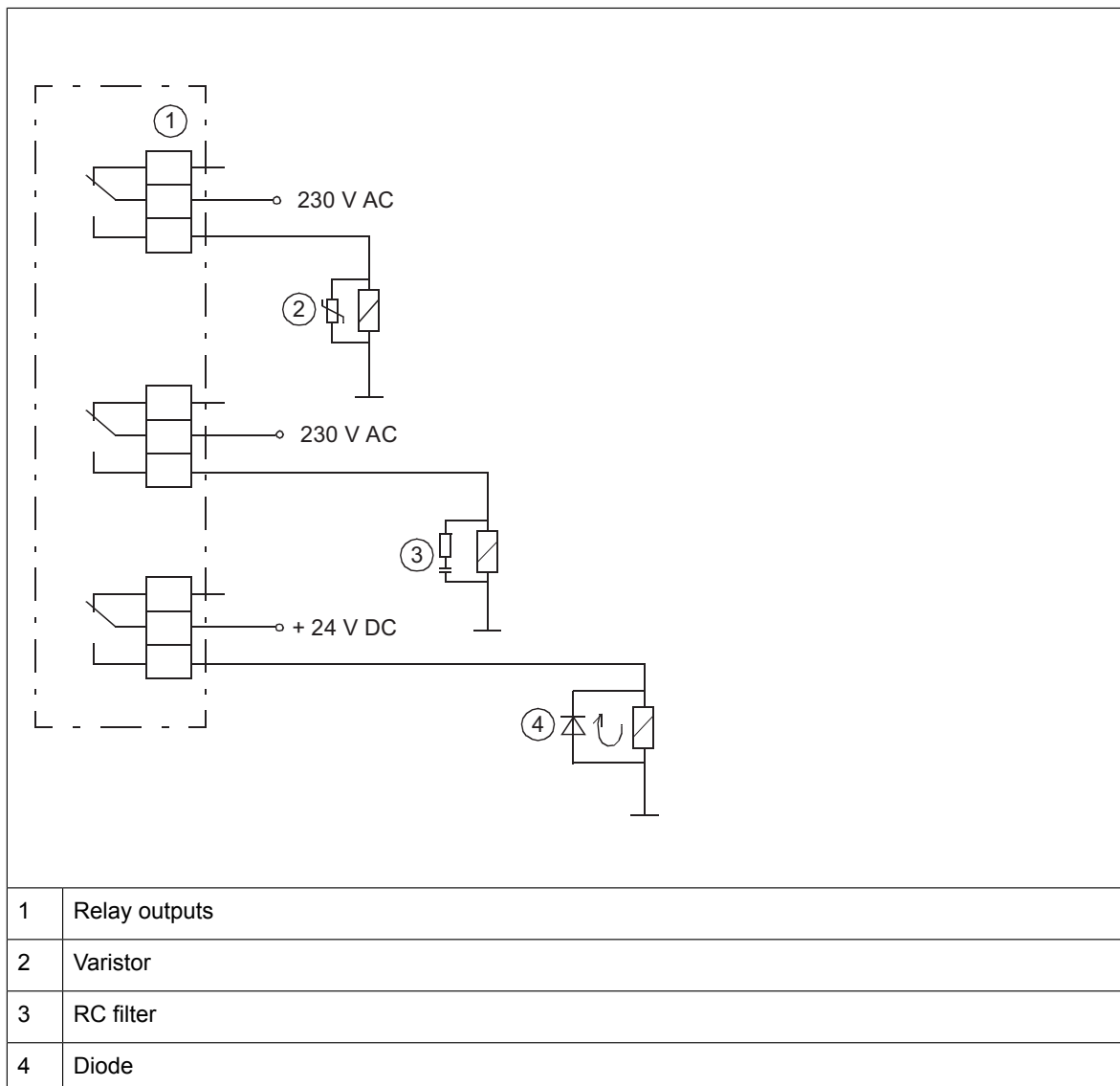

6

Electrical installation

Contents of this chapter

The chapter describes how to check the insulation of the assembly and the compatibility with IT (ungrounded) and corner-grounded TN systems. It then shows how to connect the power and control cables, install optional modules and connect a PC.

Warnings

**WARNING!**

Obey the instructions in chapter [Safety instructions](#). If you ignore them, injury or death, or damage to the equipment can occur.

Make sure that the drive is disconnected from the input power during installation. If the drive is already connected to the input power, wait for 5 minutes after disconnecting the input power.

Required tools

To perform the electrical installation, you need the following tools:

- wire stripper
- screwdriver and/or wrench with a set of suitable bits.

Checking the insulation of the assembly

■ Drive

Do not make any voltage tolerance or insulation resistance tests on any part of the drive. Voltage tolerance or insurance resistance tests can result in damage of the drive. Every drive has been tested for insulation between the main circuit and the chassis at the factory.



Also, there are voltage-limiting circuits inside the drive which cut down the testing voltage automatically.

■ Input power cable

Check the insulation of the input cable according to local regulations before connecting it to the drive.

■ Checking the insulation of the motor and motor cable



WARNING!

Obey the safety instructions of the drive. If you ignore them, injury or death, or damage to the equipment can occur.

If you are not a qualified electrician, do not do installation or maintenance work.

1. Stop the drive and do the steps in section *Electrical safety precautions (page 16)* before you start the work.
2. Check that the motor cable is disconnected from the drive output terminals U2, V2 and W2.
3. Measure the insulation resistance between the phase conductors and then between each phase conductor and the Protective Earth conductor. Use a measuring voltage of 1000 V DC. The insulation resistance of an ABB motor must exceed 100 Mohm (reference value at 25 °C or 77 °F). For the insulation resistance of other motors, consult the manufacturer's instructions.

Note:

Moisture inside the motor casing reduces the insulation resistance. If moisture is suspected, dry the motor and repeat the measurement.

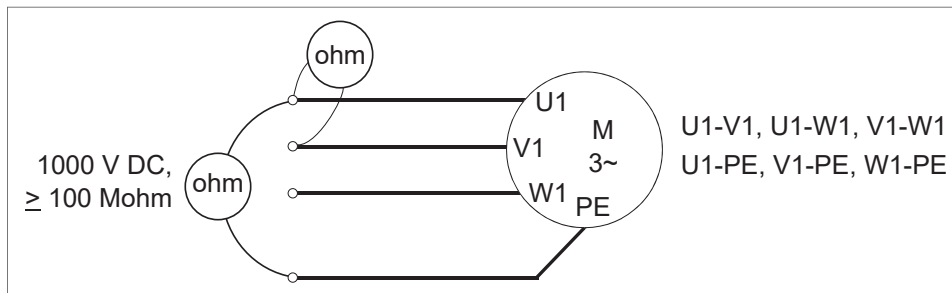

■ Brake resistor assembly R0...R3

Check the insulation of the brake resistor assembly (if present) as follows:

1. Check that the resistor cable is connected to the resistor, and disconnected from the drive output terminals R+ and R-.
2. At the drive end, connect the R+ and R- conductors of the resistor cable together. Measure the insulation resistance between the combined conductors and the PE conductor by using a measuring voltage of 1 kV DC. The insulation resistance must be higher than 1 Mohm.

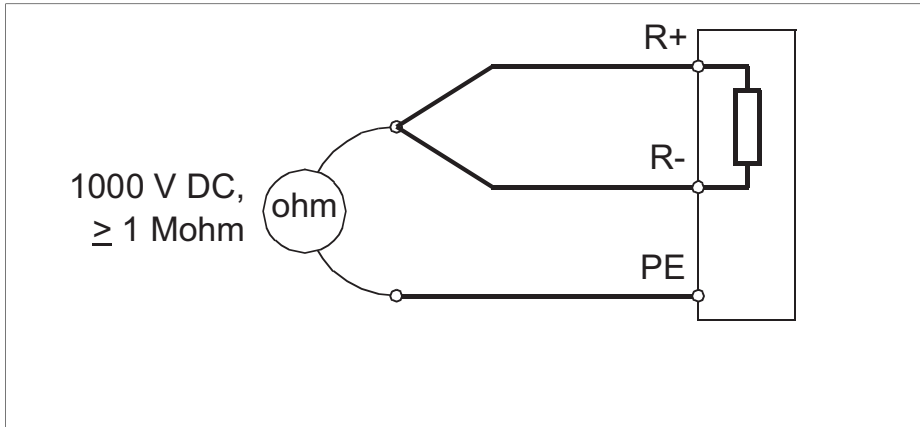

Checking the compatibility with IT (ungrounded) and corner-grounded TN systems

■ EMC filter

The internal EMC filter is not suitable for use on an IT (ungrounded) system or on a corner-grounded TN system. Disconnect the EMC filter before connecting the drive to the supply network. Check the table in [Ground-to-phase varistor \(page 69\)](#).



WARNING! WARNING!

Do not install the drive with the internal EMC filter connected on an IT system (an ungrounded power system or a high-resistance-grounded [over 30 ohms] power system), otherwise the system will be connected to ground potential through the EMC filter capacitors of the drive. This can cause danger, or damage the drive.

Do not install the drive with the internal EMC filter connected on a corner-grounded TN system, otherwise the drive will be damaged.

■ Ground-to-phase varistor

The ground-to-phase varistor is not suitable for use on an IT (ungrounded) system. Disconnect the ground-to-phase varistor before connecting the drive to the supply network. Check the table below.



WARNING! WARNING!

Do not install the drive with the ground-to-phase varistor connected on an IT system (an ungrounded power system or a high-resistance-grounded [over 30 ohms] power system), otherwise the varistor circuit can be damaged.

Check from the table below if you have to disconnect the EMC filter (EMC) or ground-to-phase varistor (VAR).

Frame sizes	EMC filter (EMC)	Ground-to-phase varistor (VAR)	Symmetrically grounded TN systems (TN-S systems) ¹	Corner grounded TN systems ²	IT systems (ungrounded or high-resistance grounded [$>30 \text{ ohms}$]) ³
R0...R3	EMC (1 screw)	-	Do not disconnect	Disconnect	Disconnect
	-	VAR (1 screw)	Do not disconnect	Do not disconnect	Disconnect

Frame sizes	EMC filter (EMC)	Ground- to-phase varistor (VAR)	Symmetrically grounded TN systems (TN-S systems) ¹	Corner grounded TN systems ²	IT systems (un-grounded or high-resistance grounded [>30 ohms]) ³
R4...R5	EMC (2 screws)	-	Do not disconnect	Frames R4 and R5 cannot be used in corner grounded TN systems.	Disconnect
	-	VAR (1 screw)	Do not disconnect		Disconnect
R6...R8	EMC (2 screws)	-	Do not disconnect	Disconnect	Disconnect
	-	VAR(1 screw)	Do not disconnect	Do not disconnect	Disconnect

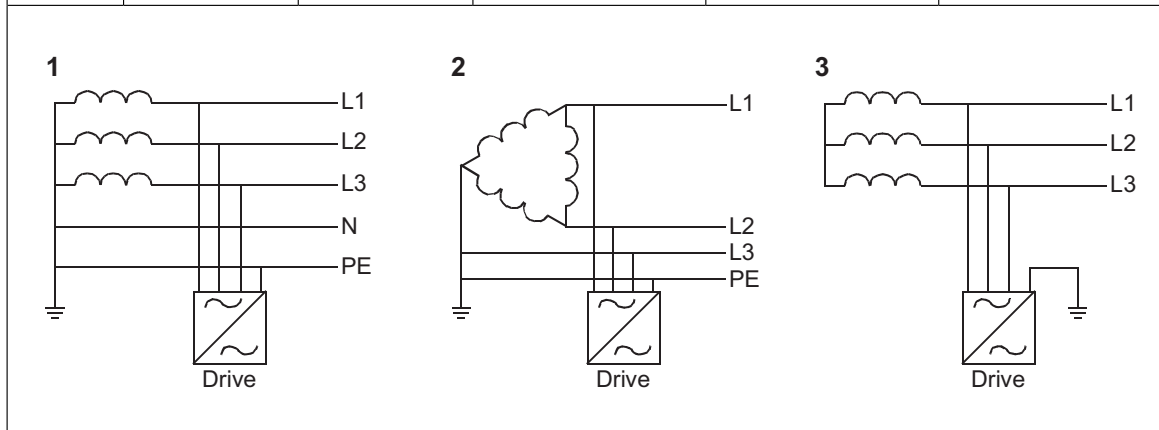

■ Frames R0...R3

To disconnect the internal EMC filter or ground-to-phase varistor, if needed, do as follows:

1. Switch off the power from the drive.
2. Open the front cover, if not already opened. For R0...R2, see [Connection procedure: frames R0...R2 \(page 75\)](#) and for R3 see section [Connection procedure, frames R3...R4 \(page 79\)](#).
3. To disconnect the internal EMC filter, remove the EMC grounding screw.



4. To disconnect the ground-to-phase varistor, remove the varistor grounding screw.

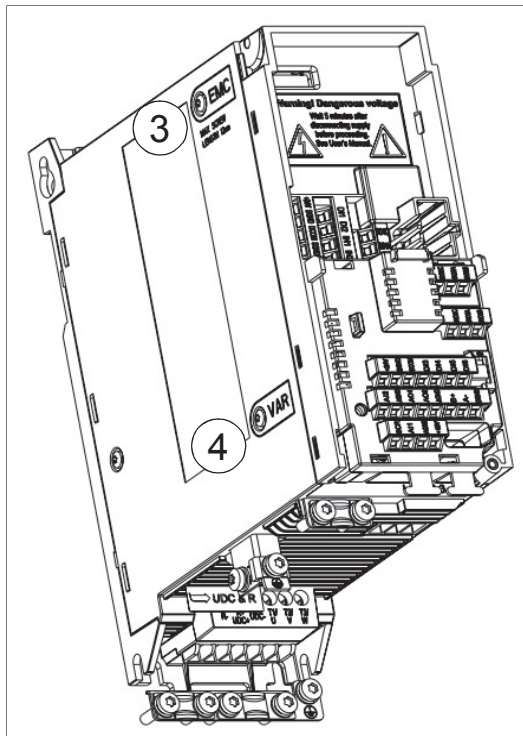

■ Frames R4...R8

To disconnect the internal EMC filter or ground-to-phase varistor, if needed, do as follows:

1. Switch off the power from the drive.
2. Open the cover, if not already opened. For frames R4, see section [Connection procedure, frames R3...R4 \(page 79\)](#). For frames R5...R8, see section [Connection procedure, frames R5...R8 \(page 83\)](#).
3. To disconnect the internal EMC filter, remove the two EMC screws.
4. To disconnect the ground-to-phase varistor, remove the varistor screw.

R4

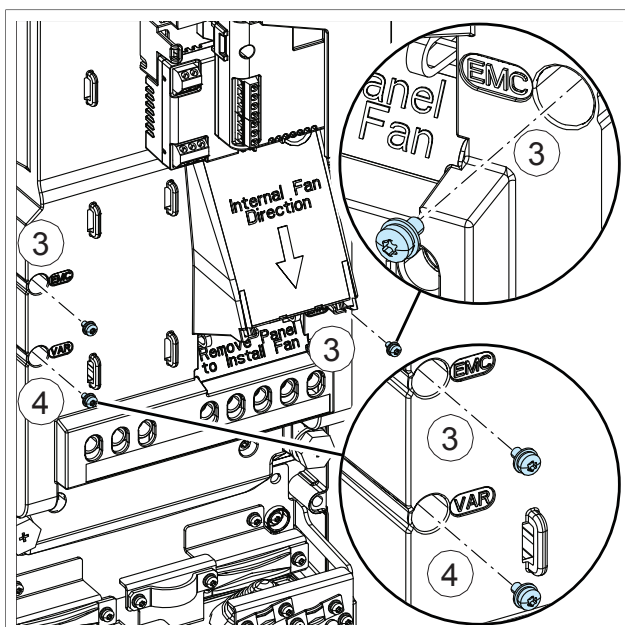

R5

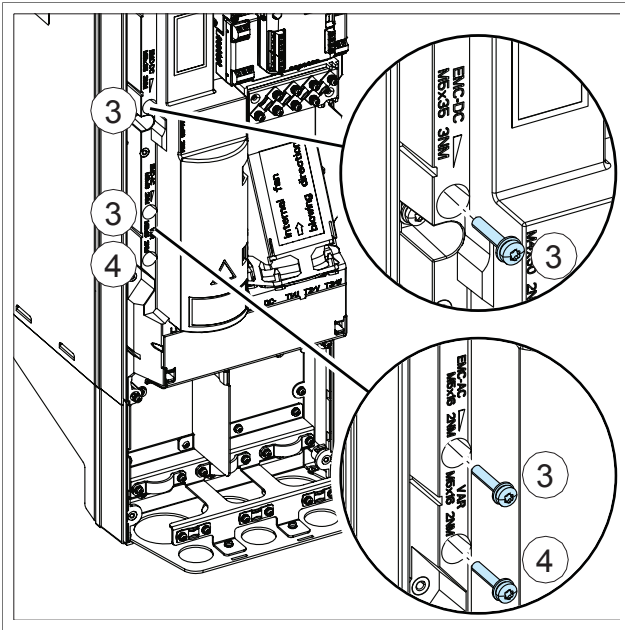

R6...R8

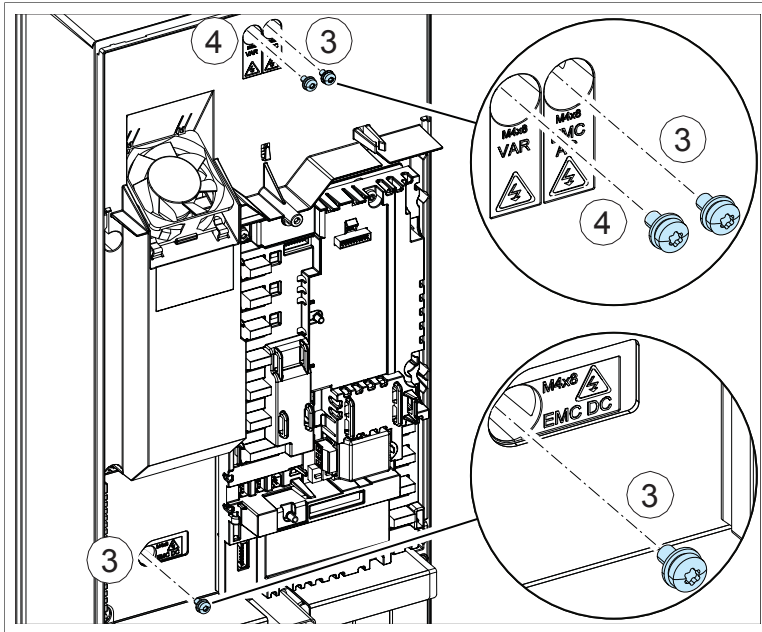

Connecting the power cables

■ Connection diagram

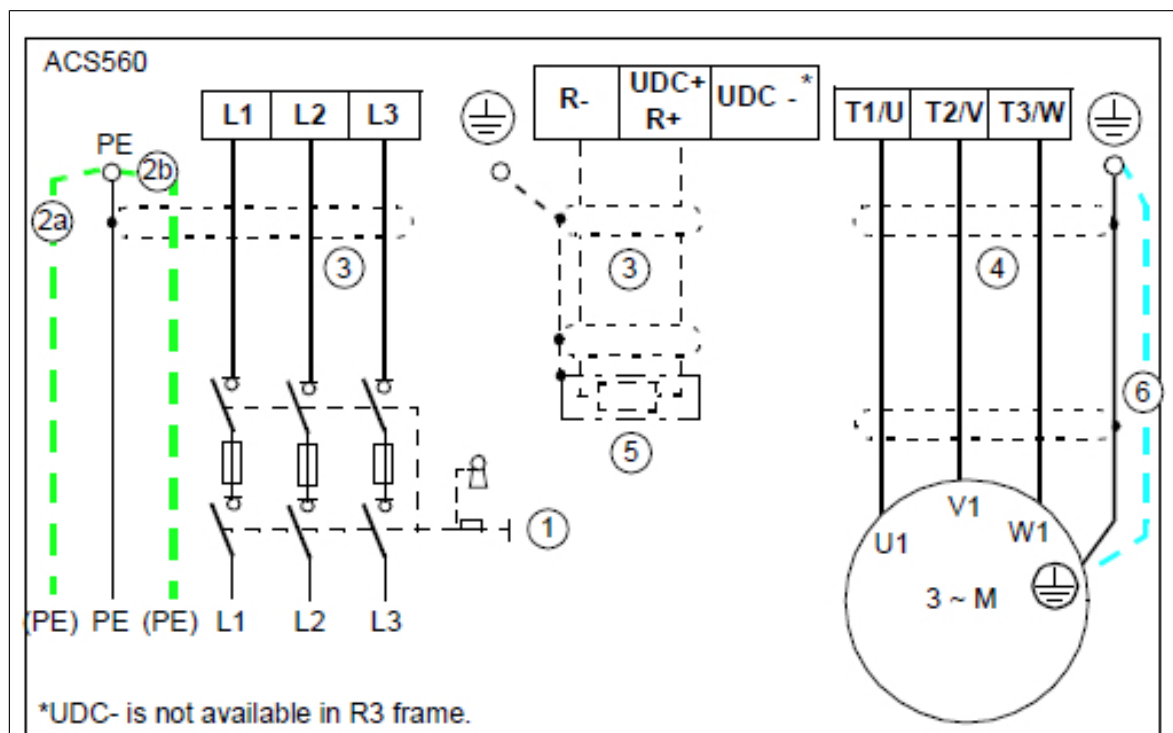

- | | |
|---|--|
| 1 | For alternatives, see section Selecting the supply disconnecting device (page 53) . |
| 2 | Use a separate grounding PE cable (2a) or a cable with a separate PE conductor (2b) if the conductivity of the shield does not meet the requirements for the PE conductor (see Selecting the power cables (page 54)). |
| 3 | 360-degree grounding is recommended if shielded cable is used. Ground the other end of the input cable shield or PE conductor at the distribution board. |

4	360-degree grounding is required.
5	External brake resistor (for frames R4...R8 only).
6	Use a separate grounding cable if the shield does not meet the requirements of IEC 61439-1 (see Selecting the power cables (page 54)) and there is no symmetrically constructed grounding conductor in the cable (see Motor cable shield (page 56)).
<p>Note: If there is a symmetrically constructed grounding conductor on the motor cable in addition to the conductive shield, connect the grounding conductor to the grounding terminal at the drive and motor ends. Do not use an asymmetrically constructed motor cable for motors above 30 kW (see Selecting the power cables (page 54)). Earthing at the motor increases bearing current and power consumption, damages the motor bearing and even the motor.</p>	



■ Connection procedure: frames R0...R2



WARNING! WARNING!

If the drive is connected on an IT (ungrounded) system, make sure that the EMC Filter and Varistor (VAR) is disconnected. See [EMC filter \(page 69\)](#).

1. Remove the front cover as follows:

- Loosen the retaining screw with a screwdriver (1a).
- Lift the cover from the bottom outwards (1b).

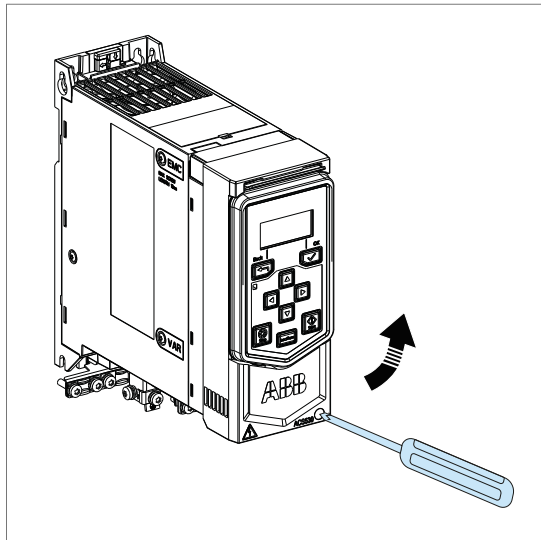

Motor cable

2. Prepare the ends of the cable as illustrated in the figure. Two different motor cable types are shown in the figures (2a. and 2b).

Note:

The bare shield will be grounded 360 degrees.

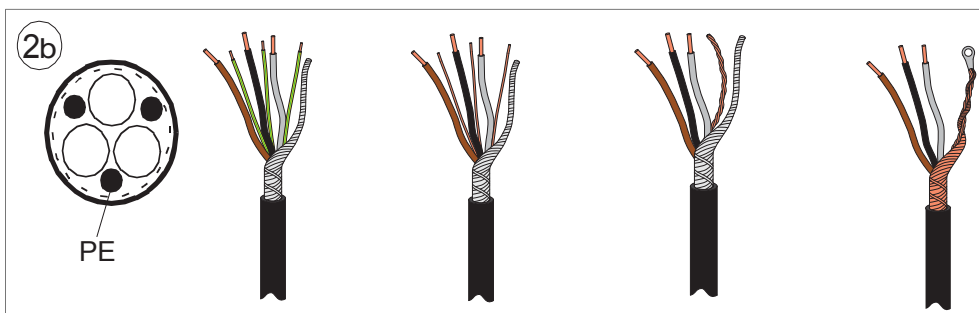
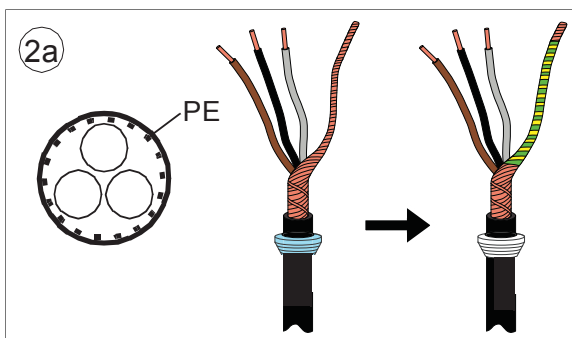

3. Connect the motor cable as follows:

- Ground the shield 360 degrees by tightening the clamp of the power cable grounding shelf onto the stripped part of the cable (3a).
- Connect the twisted shield of the cable to the grounding terminal (3b).
- Connect the phase conductors of the cable to the terminals of T1/U, T2/V and T3/W.

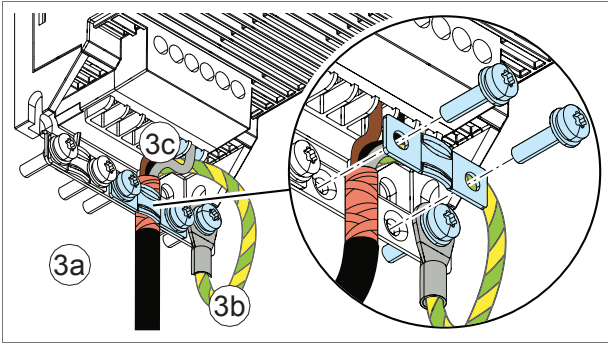

- Tighten the screws to the torque given below.

Frame size	R0...R1		R2	
	N·m	lbf·ft	N·m	lbf·ft
T1/U. T2/V. T3/W	0.5...0.6	0.4	1.2...1.5	0.9...1.1

Input power cable

4. Prepare the ends of the cable as illustrated in the figure.

Note:

The bare shield will be grounded 360 degrees. Mark the pigtail made from the shield as a PE conductor with yellow-and-green color

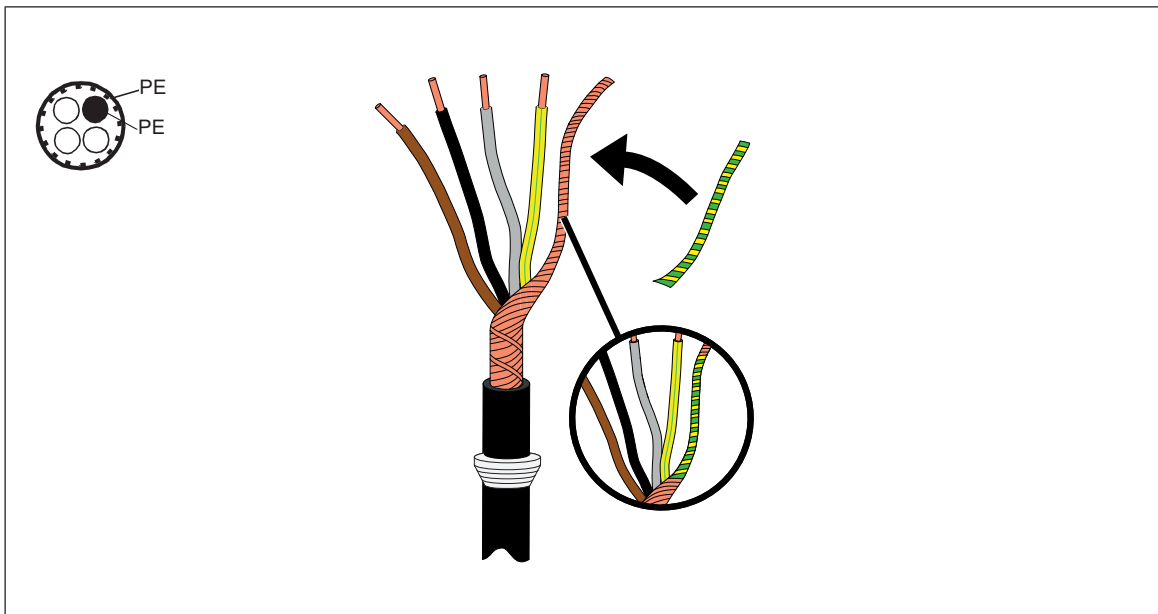

5. Connect the input power cable as follows:

- Connect the twisted shield of the cable to the grounding terminal (5a).

- Connect the phase conductors of the cable to the L1, L2 and L3 terminals.

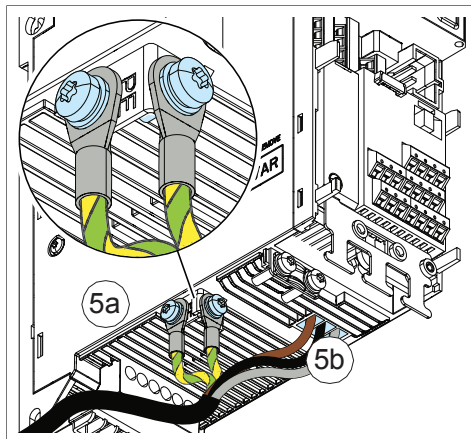

- Tighten the screws to the torque given below:

Frame size	R0...R1		R2	
	N·m	lbf·ft	N·m	lbf·ft
L1, L2, L3	0.5...0.6	0.4	1.2...1.5	0.9...1.1

6. Connect the braking resistor cable as the motor cable. See step 3.

7. Ground the shield 360 degrees (6a).

8. Connect the twisted shield to the grounding terminal (6b) and the conductors to the UDC+/R+ and R- terminals (6c).

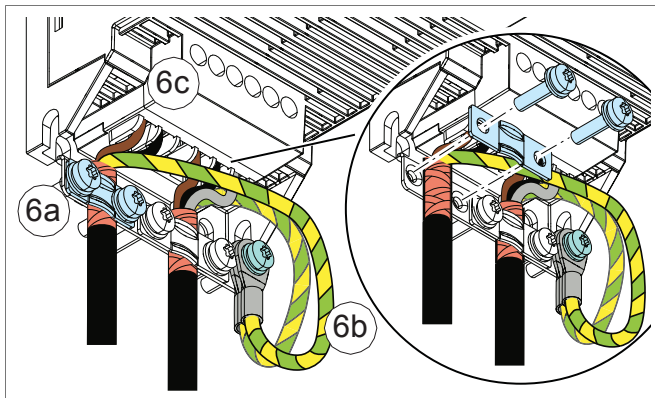

9. Tighten the screws to the torque given below.

Frame size	R0...R1		R2	
	N·m	lbf·ft	N·m	lbf·ft
UDC+/R+, R-	0.5...0.6	0.4	1.2...1.5	0.9...1.1

Finalization

10. Ground the motor cable shield at the motor end. For minimum radio frequency interference, ground the motor cable shield 360 degrees at the lead-through of the motor terminal box

78 Electrical installation

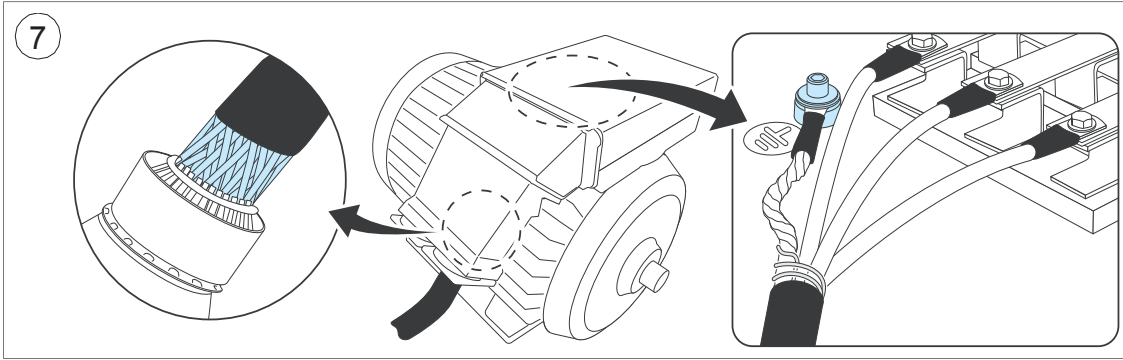

■ Connection procedure, frames R3...R4



WARNING! WARNING!

If the drive is connected on an IT (ungrounded) system, make sure you have disconnected the EMC Filter and Varistor (VAR). See [EMC filter \(page 69\)](#).

1. Remove the front cover as follows:

- Loosen the retaining screw with a screwdriver (1a).
- Push the front cover upward to uncouple top buckle (1b), and lift the cover from the bottom outwards (1c).

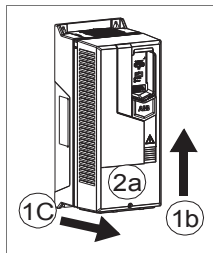

Motor cable

2. Prepare the ends of the cable as illustrated in the figure. Two different motor cable types are shown in the figures 2a and 2b.

Note:

The bare shield will be grounded 360 degrees.

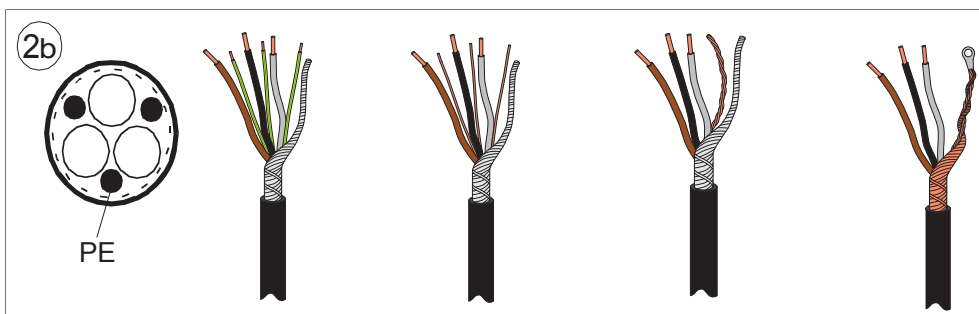
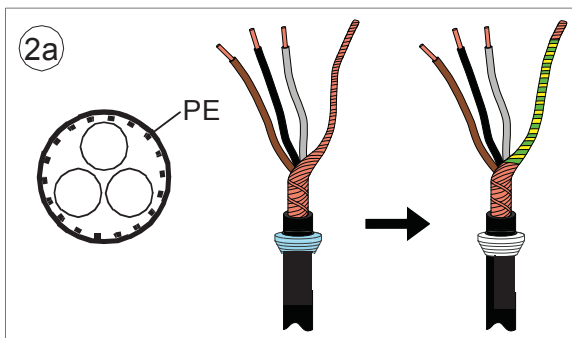

3. Connect the motor cable as follows:

If the power cable is temporarily removed from the grounding shelf, connect the motor and input power cables except the 360 degree grounding, and then reinstall the grounding shelf.

- Ground the shield 360 degrees by tightening the clamp of the power cable grounding shelf onto the stripped part of the cable (4a).

- Connect the twisted shield of the cable to the grounding terminal (4b).
- Connect the phase conductors of the cable to the T1/U, T2/V and T3/W terminals.
- Tighten the screws to the torque given below:

Frame size	R3		R4	
	N·m	lbf·ft	N·m	lbf·ft
T1/U. T2/V. T3/W.	2.5...4.5	1.8...3.3	4.0	3.0

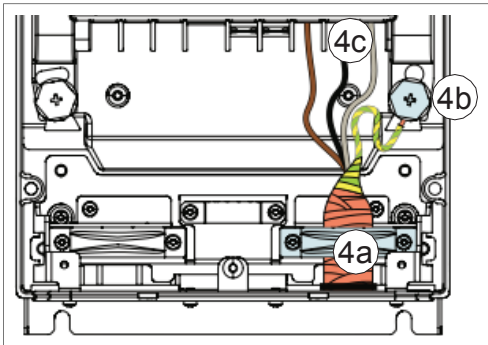

Note:

- The screws are of different length. Install them at correct locations.
- After reinstalling the grounding shelf, you can make the 360 degree grounding for the cables.

Input power cable

4. Prepare the ends of the cable as illustrated in the figure.

Note:

The bare shield is grounded 360 degrees. Mark the pigtail made from the shield as a PE conductor with yellow-and-green color.

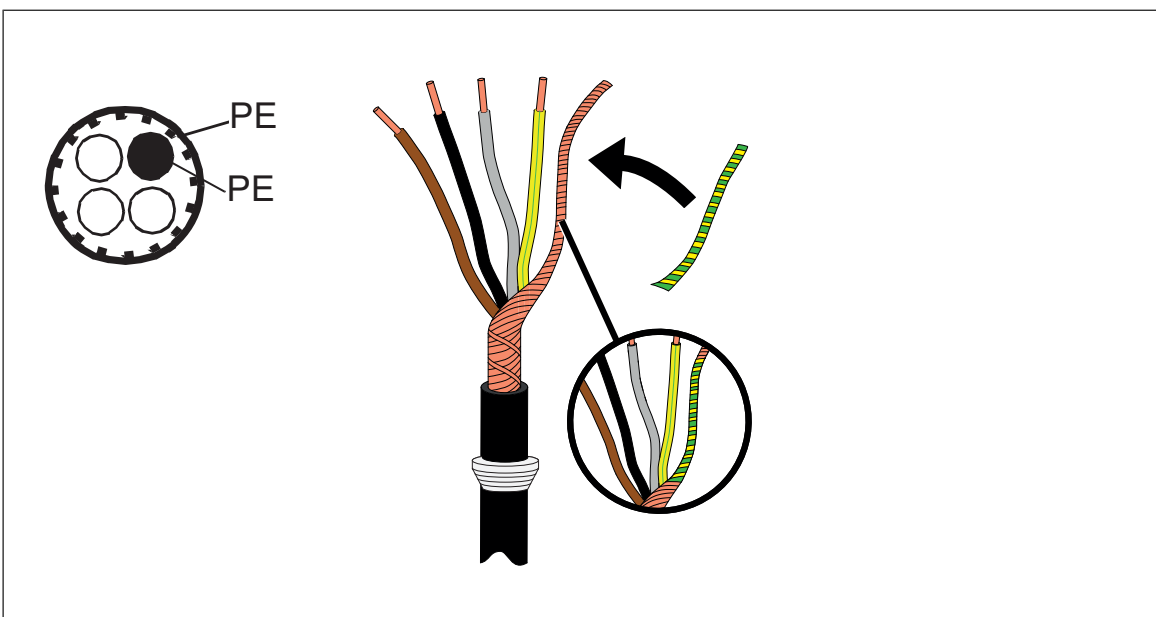

5. Connect the input power cable as follows:

- Ground the shield 360 degrees by tightening the clamp of the power cable grounding shelf onto the stripped part of the cable (6a).
- Connect the twisted shield of the cable to the grounding terminal (6b).
- Connect the phase conductors of the cable to the terminals of L1, L2 and L3.
- Tighten the screws to the torque given below.

Frame size	R3		R4	
	N·m	lbf·ft	N·m	lbf·ft
L1, L2, L3	2.5...4.5	1.8...3.3	4.0	3.0

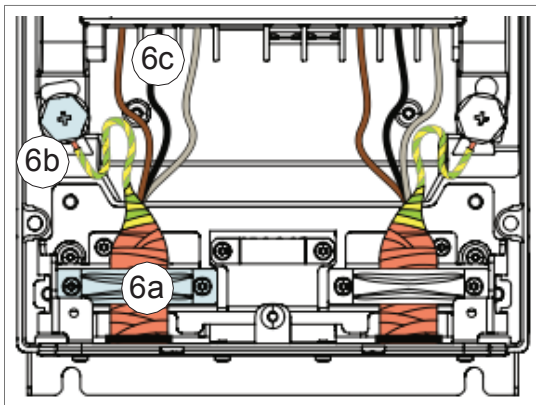

6. Connect cable by the motor cable method mentioned in step 3.
7. Ground the shield 360 degrees (7a).
8. Connect the twisted shield to the grounding terminal (7b).
9. For R3, connect the conductors to the R+ and R- terminals (7c).
10. Tighten to the torque given below.

Frame size	R3	
	N.m	lbf.ft
R+, R-	2.5...4.5	1.8...3.3

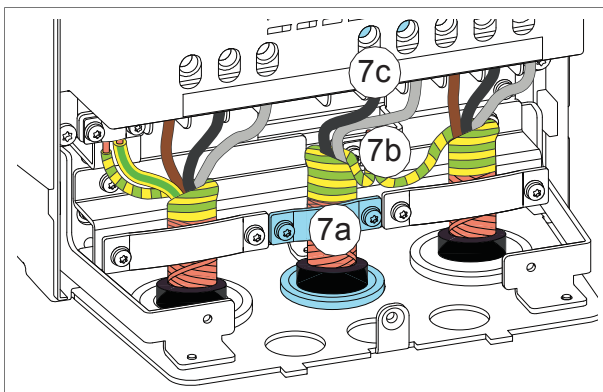

Finalization

11. Install the grounding shelf for the control cables (included with the mounting screws in a plastic bag in the delivery) onto the grounding shelf for the power cables.

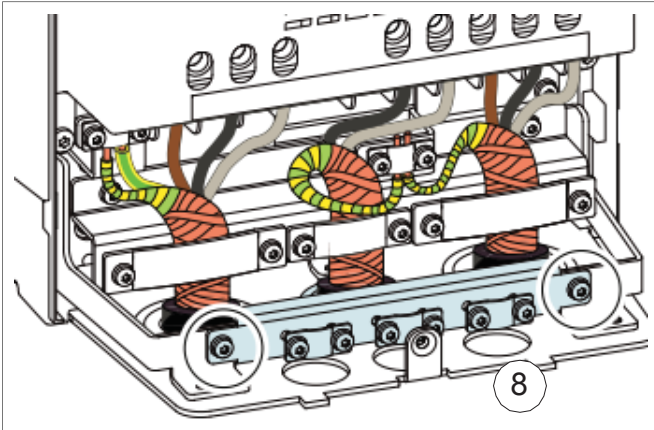

12. Ground the motor cable shield at the motor end. For minimum radio frequency interference, ground the motor cable shield 360 degrees at the lead-through of the motor terminal box

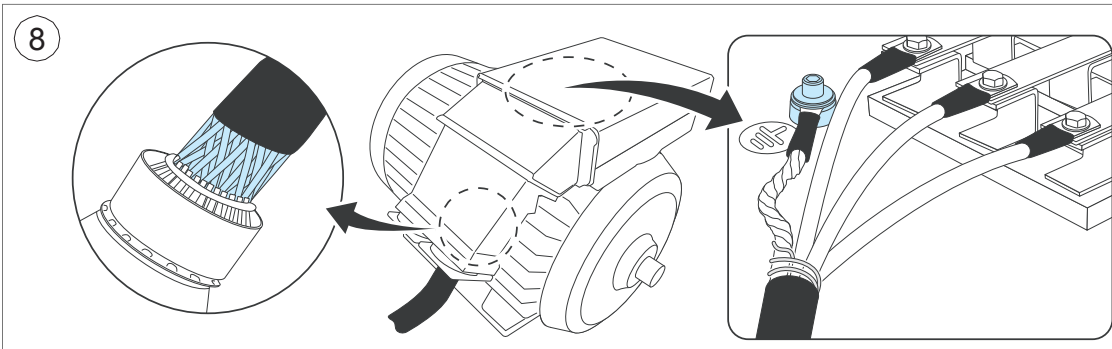

■ Connection procedure, frames R5...R8



WARNING! WARNING!

If the drive will be connected on an IT (ungrounded) system, make sure you have disconnected the EMC Filter and Varistor (VAR). See *EMC filter (page 69)*.

1. Attach the residual voltage warning sticker next to the control board.
2. Remove the side plates of the cable box as follows:
 - Remove the retaining screws.
 - Slide the walls out.

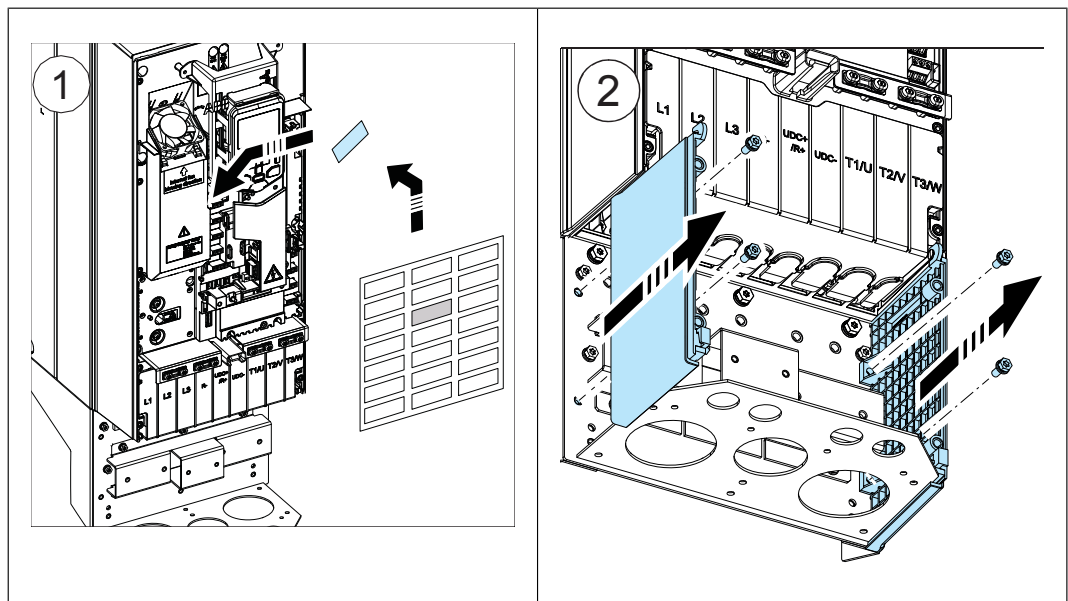

3. Remove the shroud on the power cable terminals by releasing the clips with a screwdriver and pulling the shroud out.
4. Knock out holes in the shroud for the cables to be installed.
5. Frame R8 only: If you install parallel cables, also knock out holes in the lower shroud for the cables to be installed.



Frame R8

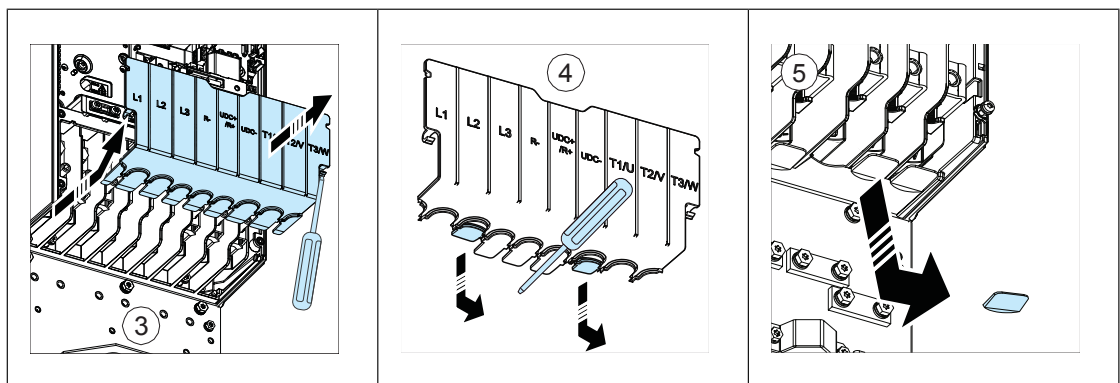

Motor cable

6. Cut an adequate hole into the rubber grommet. Slide the grommet onto the cable.

7. Prepare the ends of the input power cable and motor cable as illustrated in the figure. If you use aluminum cables, put grease to the peeled aluminum cable before connecting it to the drive. Two different motor cable types are shown in the figures (7a, 7b).

Note:

The bare shield is grounded 360 degrees. Mark the pigtail made from the shield as a PE conductor with yellow-and-green color.

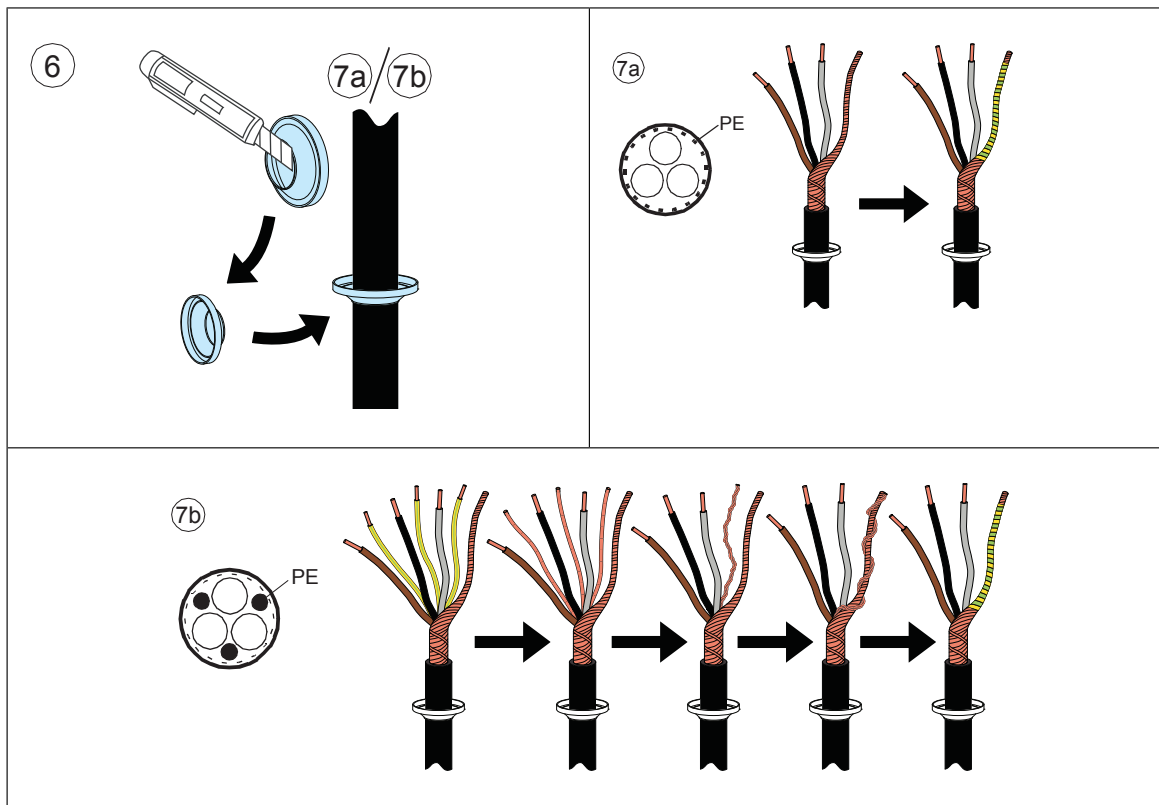

8. Slide the cables through the holes of the lead-through plate and attach the grommets to the holes (the motor cable to the right and the input power cable to the left).

9. Connect the motor cable as follows:

- Ground the shield 360 degrees under the grounding clamps.
- Connect the twisted shield of the cable to the grounding terminal (9a).
- Connect the phase conductors of the cable to terminals T1/U, T2/V and T3/W. Tighten the screws to the torque given in the figure (9b).

Note: Frame R8 only:

- If you connected the connector to only one conductor, ABB recommends to put the conductor under the upper pressure plate.
- The connectors are detachable, but ABB recommends not to detach them. If you do, detach and reinstall the connectors as follows.

Input power cable

10. Connect the input power cable as in step 9.

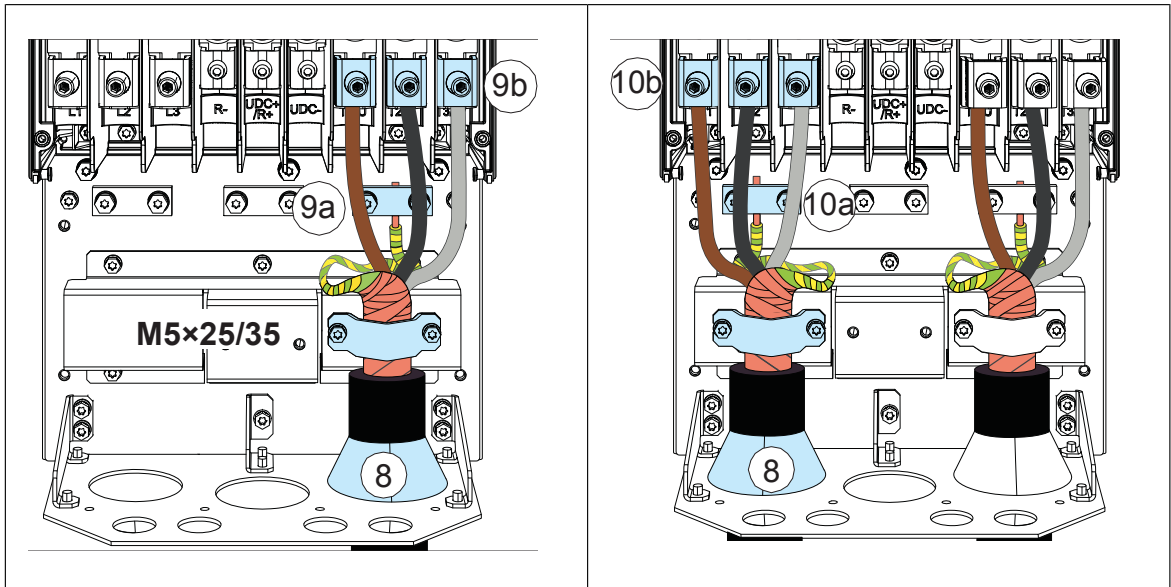

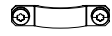
Frame size	L1, L2, L3, T1/U, T2/V, T3/W		PE 			
	N·m	lbf·ft	N·m	lbf·ft	N·m	lbf·ft
R5	5.6	4.1	2.2	1.6	1.2	0.9
R6	30	22.1	9.8	7.2	1.2	0.9
R7	40	29.5	9.8	7.2	1.2	0.9
R8	40	29.5	9.8	7.2	1.2	0.9

Terminals T1/U, T2/V and T3/W

- Remove the nut attached to the connector and its busbar.
- Put the conductor under the connector pressure plate and pre-tighten the conductor.
- Put the connector back to its busbar. Start the nut, and turn it by hand to at least two rotations.



WARNING! WARNING!

Before using tools, make sure that the nut/screw is not cross-threaded. Cross-threading damages the drive and causes danger.

- Tighten the nut to a torque of 30 N·m (22 lbf·ft).
- Tighten the conductor(s) to 40 N·m (30 lbf·ft) for frame R8 or to 70 N·m (52 lbf·ft) for frame R8.

Terminals L1, L2 and L3

- Remove the combi screw attached to the connector and to its terminal post, and pull the connector off.
- Put the conductor under the connector pressure plate and pre-tighten the conductor.
- Put the connector back onto the terminal post. Start the combi screw, and turn it by hand to at least two rotations.





WARNING! WARNING!

Before using tools, make sure that the nut/screw is not cross-threaded. Cross-threading can damage the drive and cause danger.

- Tighten the combi screw to a torque of 30 N·m (22 lbf·ft).
- Tighten the conductor(s) to 40 N·m (30 lbf·ft) for frame R8 or to 70 N·m (52 lbf·ft) for frame R8.

11. Frames R8 only: If you install parallel cables, install the second grounding shelf for the parallel power cables (11a). Repeat steps 6...11 (11b).

Frame R8:

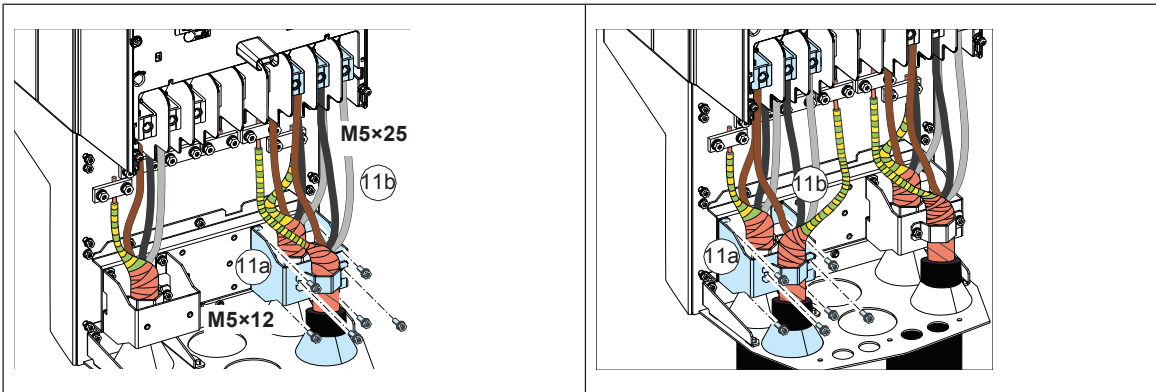

12. Install the grounding shelf of the control cables.

13. Reinstall the shroud on the power terminals.

14. Secure the cables outside the unit mechanically.

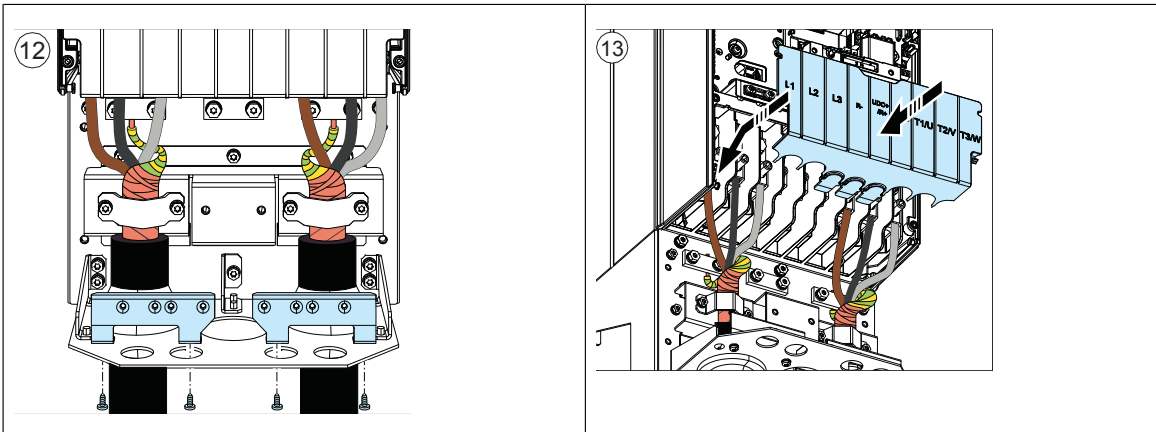

15. Ground the motor cable shield at the motor end. For minimum radio frequency interference, ground the motor cable shield 360 degrees at the lead-through of the motor terminal box.

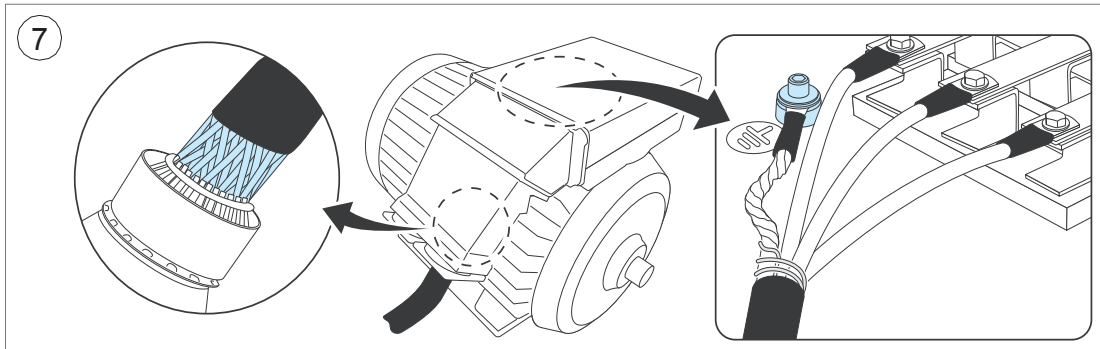

DC connection

The UDC+ and UDC- terminals (as standard in frames R4...R8) are for using external brake chopper units.

Connecting the control cables

Connect the cables as described in section [Control cable connection procedure R0...R8 \(page 93\)](#). See the below default I/O connections of ABB standard macro. See other macro connections in the firmware manual.



Default control connections of ABB standard macro

■ Connection diagram

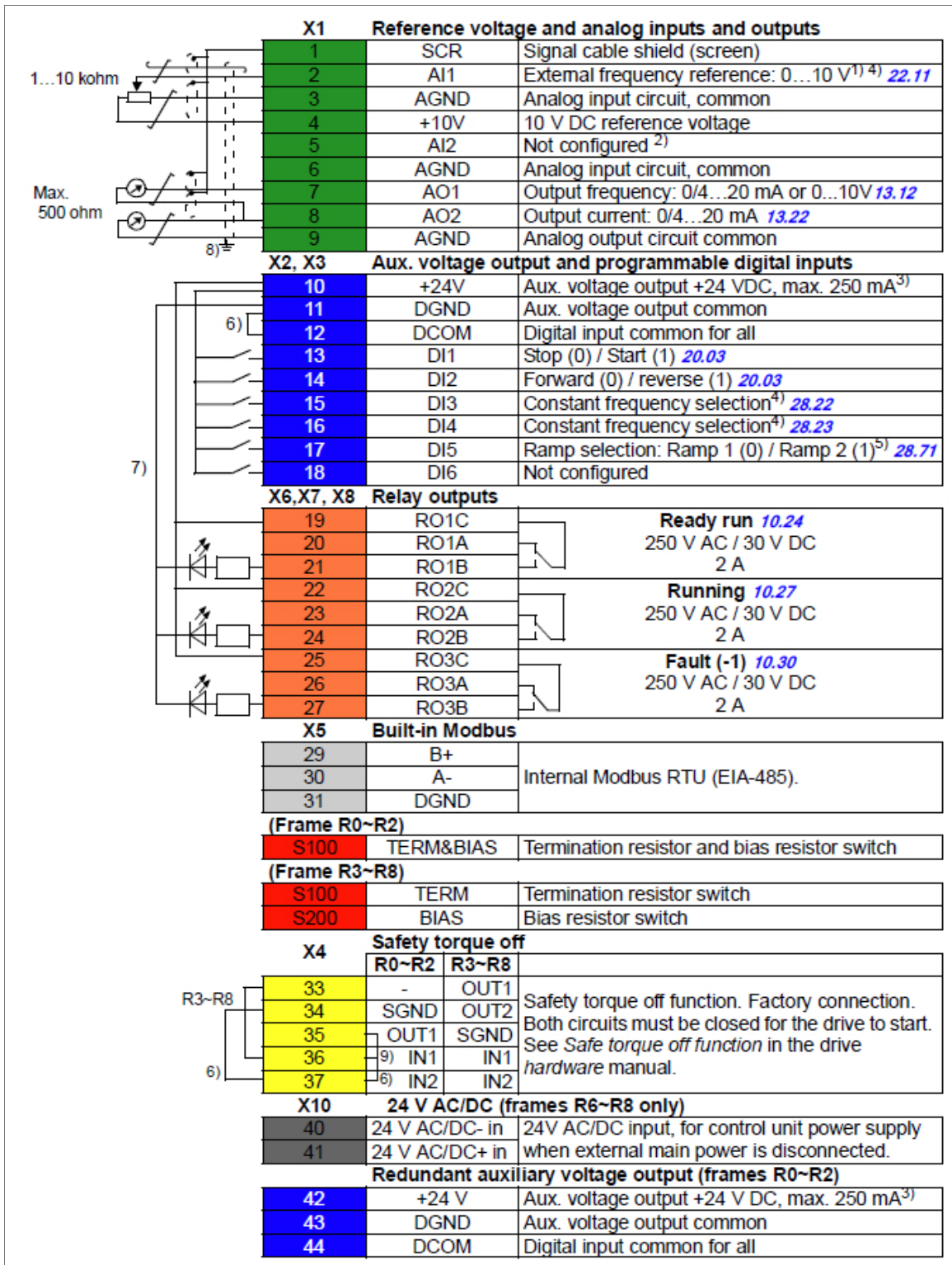

Note:

For information of parameter indexes marked in this diagram, see chapter *Parameters* in the firmware manual

Terminal sizes

- (frames R0...R8): 0.14...1.5 mm² (all terminals)
- Tightening torques: 0.5...0.6 N·m (0.4 lbf·ft)

Notes:

- 1) Current [0(4)...20 mA, $R_{in} < 500 \text{ ohm}$] or voltage [0(2)...10 V, $R_{in} > 200 \text{ kohm}$] input as selected with parameter 12.15 A11 unit selection.
- 2) Current [0(4)...20 mA, $R_{in} = 100 \text{ ohm}$] or voltage[0(2)...10 V, $R_{in} > 200 \text{ kohm}$] input as selected with parameter 12.25A12 unit selection.
- 3) Total load capacity of the auxiliary voltage output+24V (X2:10) = 6.0 W (250 mA / 24 V)
- User can use this source for either of the I/O connections (DI1... DI2- RO1 or DI3...DI6 - RO2~RO3).
- 4) The constant speed are set based on the combination of sources as follows:







Source defined by parameter 28.22	Source defined by parameter 28.23	Constant speed active
0	0	Set speed through A11
1	0	Constant frequency 1
0	1	Constant frequency 2

- 5) The speed reference ramp is set based on the combination of sources as follows:

DI5 parameter 28.71	Ramp set	Parameters
		Scalar control (default)
0	Acc/Dec time 1	28.72 time 1
		28.73 Freq deceleration time 1
1	Acc/Dec time 2	28.74 time 2
		28.75 time 2

- 6) Connected with jumpers at the factory.
- 7) Applicable for R0~R2 frames only.
- 8) Use shielded twisted-pair cables for digital signals.
- 9) Ground the outer shield of the cable 360 degrees under the grounding clamp on the grounding shelf for the control cables.
- 10) Input signal
- 11) Output signal

Switches

Switch	Description	Position	
S100 (TERM & BIAS)	Modbus link termination and biasing voltages to the bus. Set to ON position when the drive is the last unit on the link.		Term & BIAS off (default)
			Term & BIAS on
S100 (TERM)	Modbus link termination. Must be set to the terminated (ON) position when the drive is the first or last unit on the link.		BUS not terminated (default)
			BUS terminated
S200 (BIAS)	Switches on the biasing voltages to the bus. One (and only one) device, preferably at the end of the bus must have the bias on.		BIAS off (default)
			BIAS on

PNP configuration for digital inputs

Internal and external +24 V power supply connections for PNP configuration are shown in the figure below.

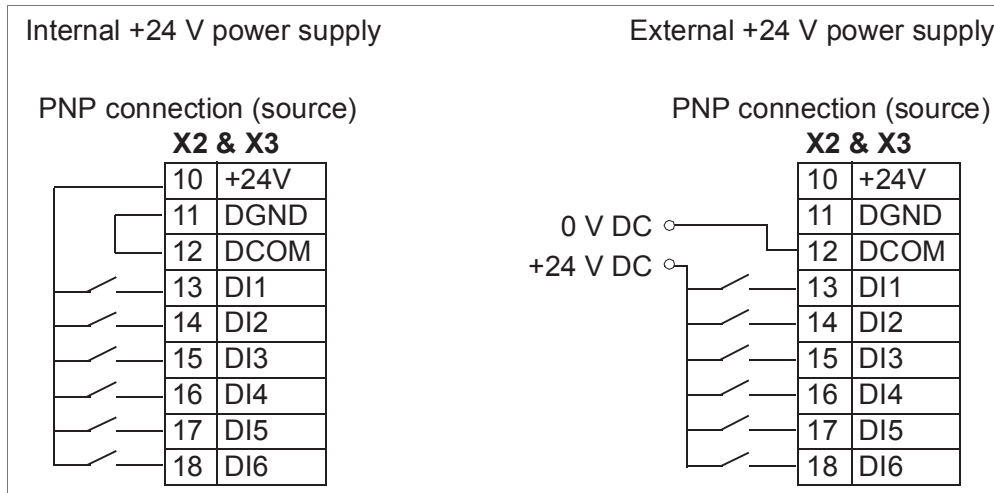

WARNING!

Do not connect the +24 V AC cable to the control board ground when the control board is powered using an external 24 V AC supply.

NPN configuration for digital inputs

Internal and external +24 V power supply connections for NPN configuration are shown in the figure below.

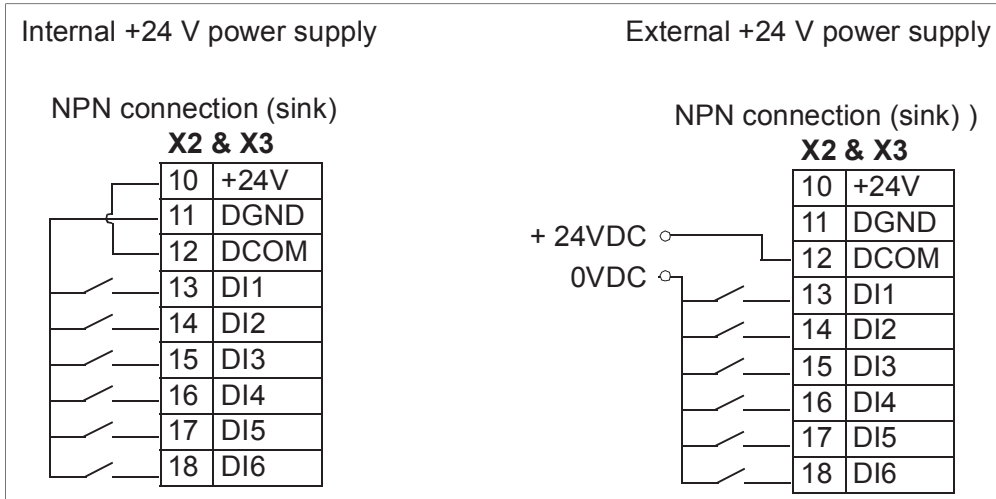

WARNING!

Do not connect the +24 V AC cable to the control board ground when the control board is powered using an external 24 V AC supply.

Connection for obtaining 0...10 V from analog output 2 (AO2)

To obtain 0...10 V from analog output AO2, connect a 500 ohm resistor (or two 1 kohm resistors in parallel) between the analog output 2 AO2 and analog common ground AGND.

Examples are shown in the figure below.

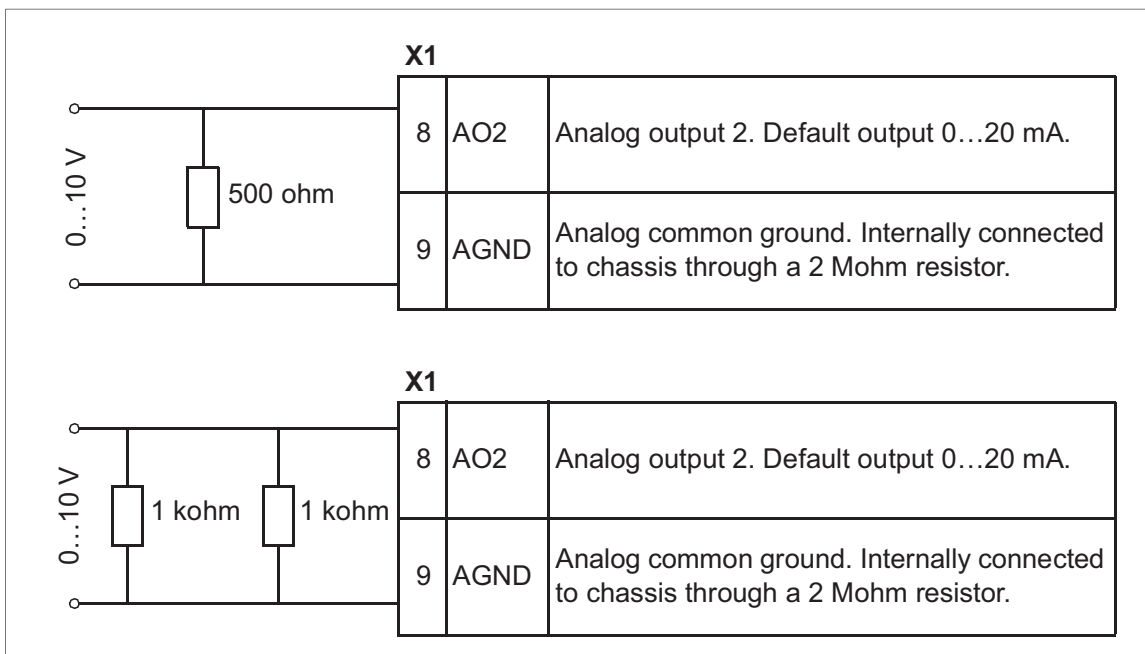

Connection examples of two-wire and three-wire sensors

PID macros (see *ACS560 firmware manual* (3AXD50000016097 [English])) use analog input 2 (AI2). The macro wiring diagrams on these pages use an externally powered sensor (connections not shown). The figures below give examples of connections using a two-wire or three-wire sensor/transmitter supplied by the drive auxiliary voltage output.

Note:

Maximum capability of the auxiliary 24 V DC (250 mA) output must not be exceeded.

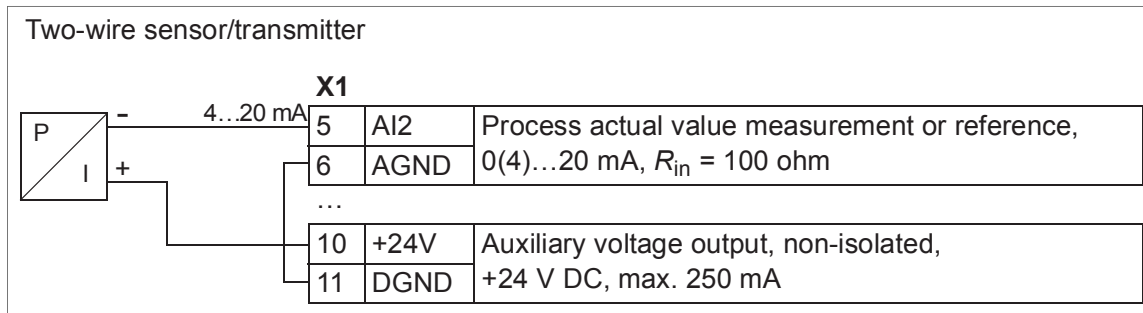

Note:

The sensor is supplied through its current output and the drive feeds the supply voltage (+24 V DC). Thus the output signal must be 4...20 mA, not 0...20 mA.

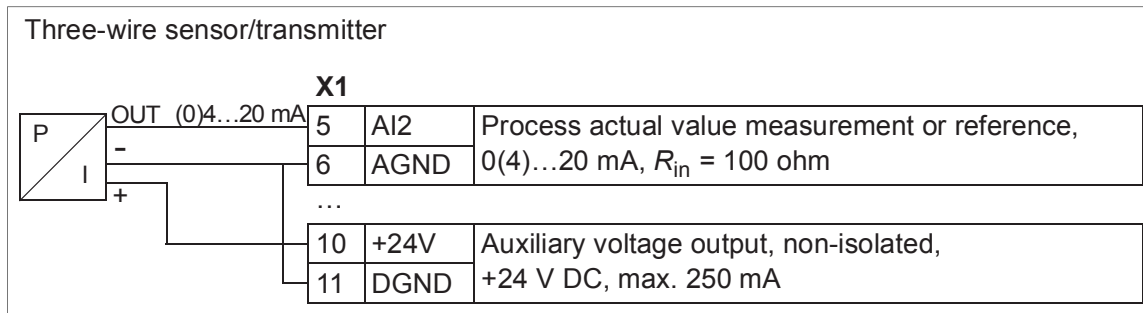

DI5 as frequency input



See section [Digital inputs DI1...DI6 \(page 134\)](#) for which digital input can be used as a frequency input in the drive. For setting the parameters for the digital frequency input, see *ACS560 standard control program firmware manual (3AXD50000044997 [English])*.

AI1 and AI2 as Pt100 sensor inputs (X1)

One, two or three Pt100 sensors for motor temperature measurement can be connected between an analog input and output as shown below. Do not connect both ends of the cable shields directly to ground, nor connect the capacitor at one end to the ground and another end directly to ground.

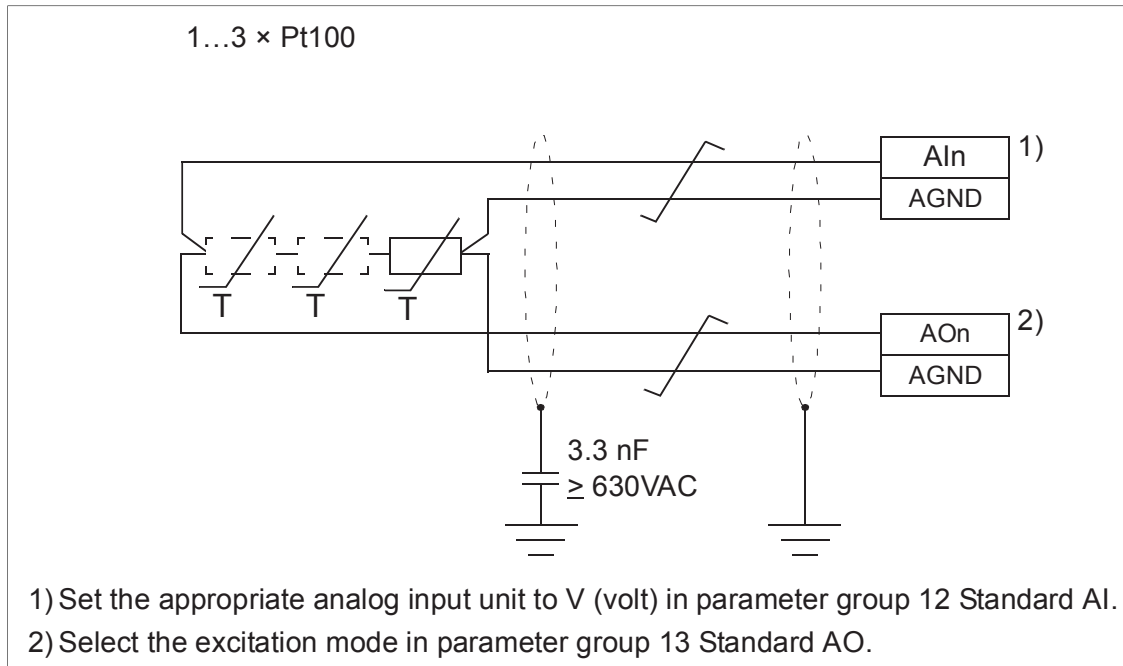
**WARNING!**

As the inputs pictured above are not insulated according to IEC 60664, the connection of the motor temperature sensor requires double or reinforced insulation between motor live parts and the sensor. If the assembly does not fulfill the requirement, the I/O board terminals must be protected against contact and must not be connected to other equipment or the temperature sensor must be isolated from the I/O terminals.

Safe torque off (X4)

For the drive to start, both connections (+24 V DC to IN1 and +24 V DC to IN2) must be closed. By default, the terminal block has jumpers to close the circuit. Remove the jumpers before connecting an external Safe torque off circuitry to the drive. See chapter [The Safe torque off function \(page 161\)](#).

Note:

Only 24 V DC can be used for STO. Only PNP input configuration can be used.

Control cable connection procedure R0...R8

**WARNING!**

Obey the instructions in chapter [Safety instructions](#). If you ignore them, injury or death, or damage to the equipment can occur.

1. Stop the drive and perform the steps in section [Electrical safety precautions \(page 16\)](#) before you start the work.
2. Remove the front cover(s) if not already removed. See section [Connection procedure: frames R0...R2 \(page 75\)](#), [Connection procedure, frames R3...R4 \(page 79\)](#) or [Installing the drive vertically, frames size R5...R8 \(page 50\)](#).

Analog signals

The figures for frames [R0...R2 \(page 95\)](#), [R3...R5 \(page 96\)](#) and [R6...R8 \(page 97\)](#) show an example of connecting a cable. Make the connections according to the macro in use.

3. Frames R4...R8: Cut an adequate hole into the rubber grommet and slide the grommet onto the cable. Slide the cable through a hole in the lead-through plate and attach the grommet to the hole.
4. Ground the outer shield of the cable 360 degrees under the grounding clamp. Keep the cable unstripped as close to the terminals of the control board as possible.
Frames R5...R8: Secure the cables mechanically at the clamps below the control board. Ground also the pair-cable shields and grounding wire at the SCR terminal.
5. Route the cable as shown in the figures [R0...R2 \(page 95\)](#) and [R6...R8 \(page 97\)](#).
6. Connect the conductors to the appropriate terminals of the control board and tighten to 0.5...0.6 N·m (0.4 lbf·ft).

Digital signals

The figures for frames [R0...R2 \(page 95\)](#), [R3...R5 \(page 96\)](#) and [R6...R8 \(page 97\)](#) show an example of connecting a cable. Make the connections according to the macro in use.

7. Frames R4...R8: Cut an adequate hole into the rubber grommet and slide the grommet onto the cable. Slide the cable through the hole in the lead-through plate and attach the grommet to the hole.
8. Ground the outer shield of the cable 360 degrees under the grounding clamp. Keep the cable unstripped as close to the terminals of the control board as possible.
Frames R5...R8: Secure the cables mechanically at the clamps below the control board. If you use double-shielded cables, ground also the pair-cable shields and grounding wire at the SCR terminal.
9. Route the cable as shown in the figures [R0...R2 \(page 95\)](#), [R3...R5 \(page 96\)](#) and [R6...R8 \(page 97\)](#).
10. Connect the conductors to the appropriate terminals of the control board and tighten to 0.5...0.6 N·m (0.4 lbf·ft).
11. Tie all control cables to the provided cable tie mounts.

Note:

- Leave the other ends of the control cable shields unconnected or ground them indirectly via a high-frequency capacitor with a few nanofarads, eg, 3.3 nF / 630 V. The shield can also be grounded directly at both ends if they are *in the same ground line* with no significant voltage drop between the end points.
- Keep any signal wire pairs twisted as close to the terminals as possible. Twisting the wire with its return wire reduces disturbances caused by inductive coupling.



■ R0...R2

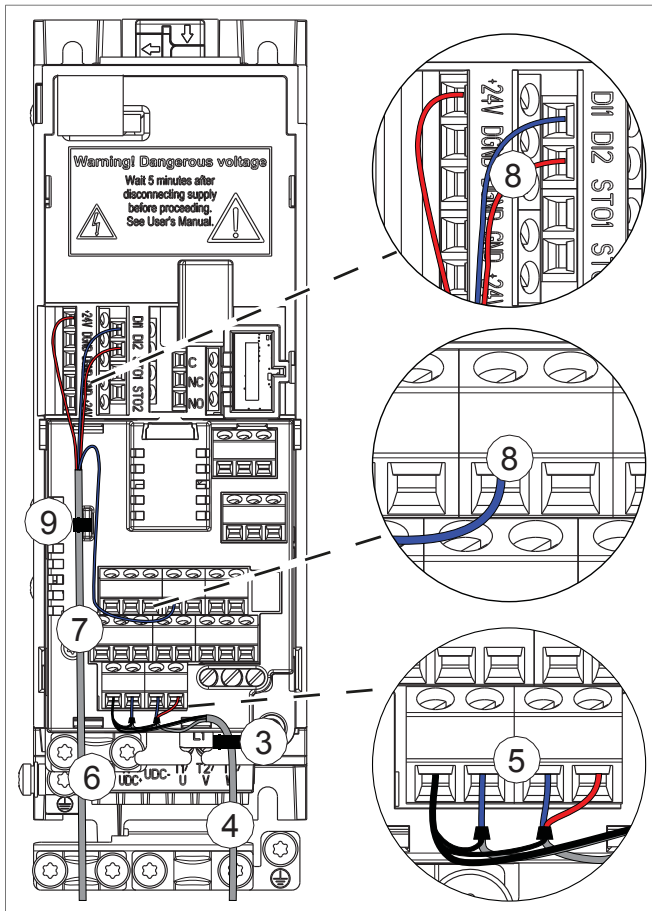

■ R3...R5

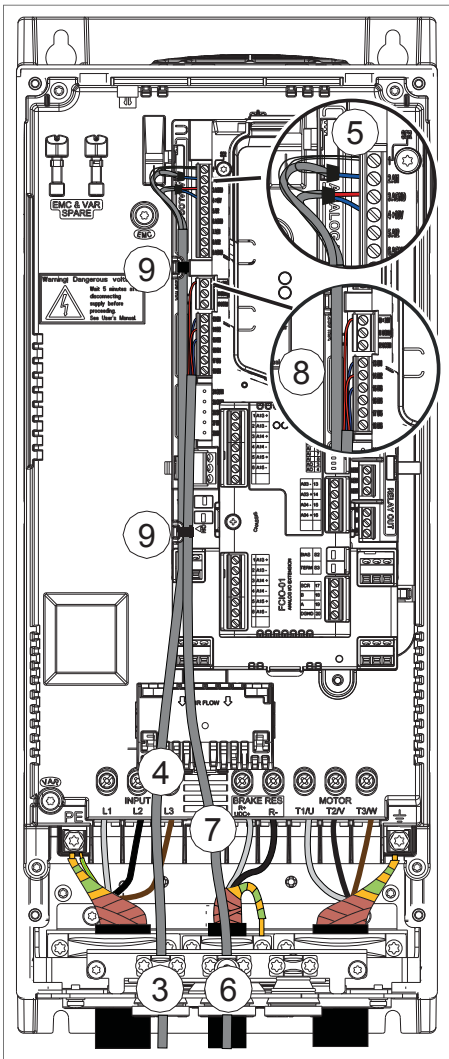

■ R6...R8

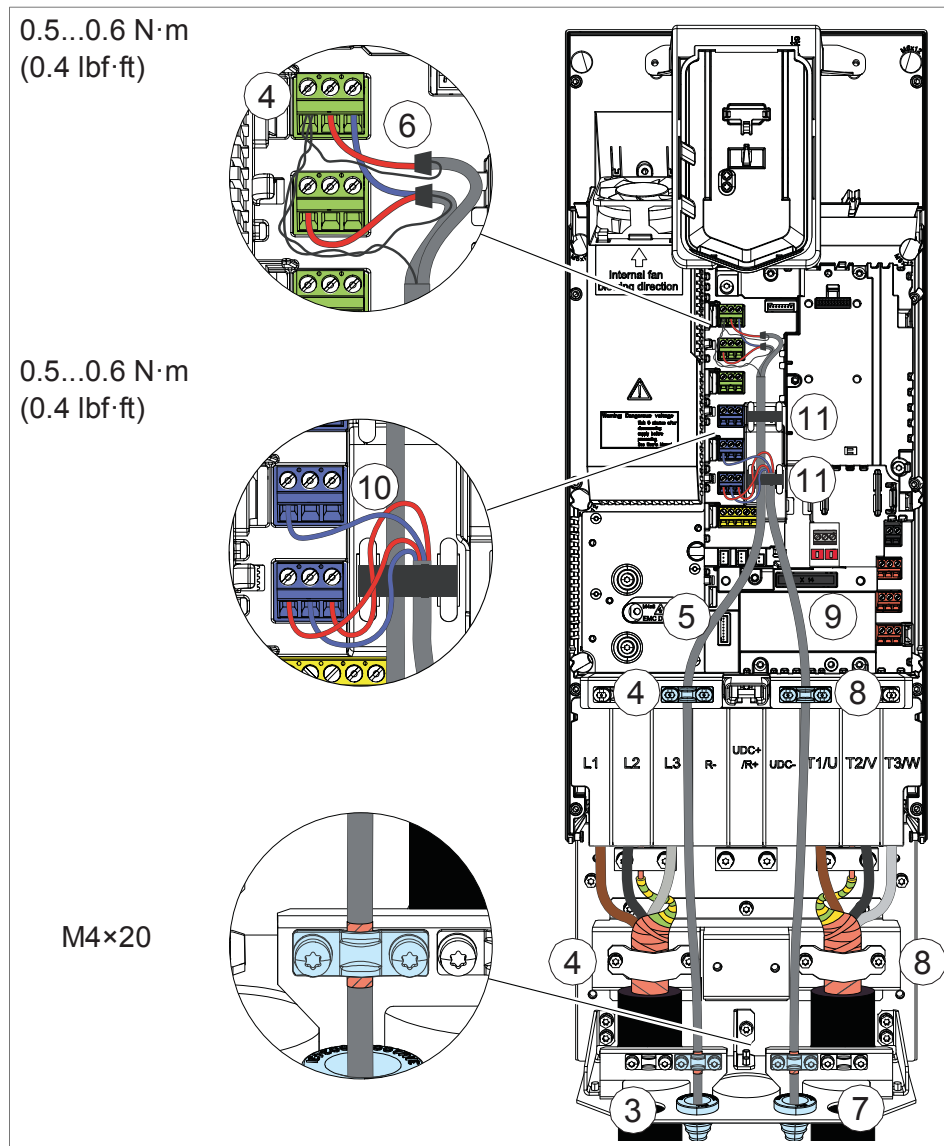

Auxiliary voltage connection (For R0...R2 frames with optional BAPO-01 module)

The drive has an auxiliary 24 V DC ($\pm 10\%$) voltage connection. Depending on the application, you can use the connection,

- To supply external power to the drive
- To supply power from the drive to external option modules

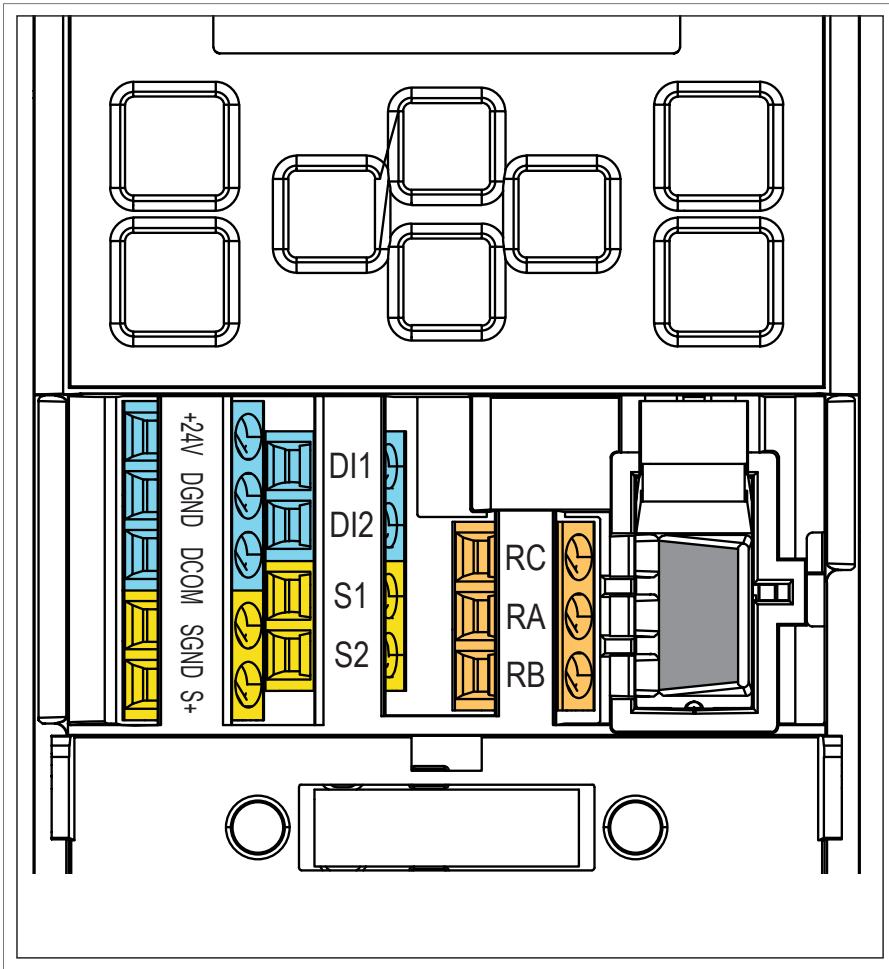

Connect the external supply or module to the +24V and DGND terminals (40 and 41).



For more information on how to feed auxiliary power to the drive, see [BAPO-01 power extension module \(page 186\)](#).

For voltage input specifications, see the technical data.

There is a DC to DC flyback converter power supply inside BAPO-01 module. This power supply takes 24 V DC as input and outputs 5 V DC to control board to keep the processor and communication links alive at all times.

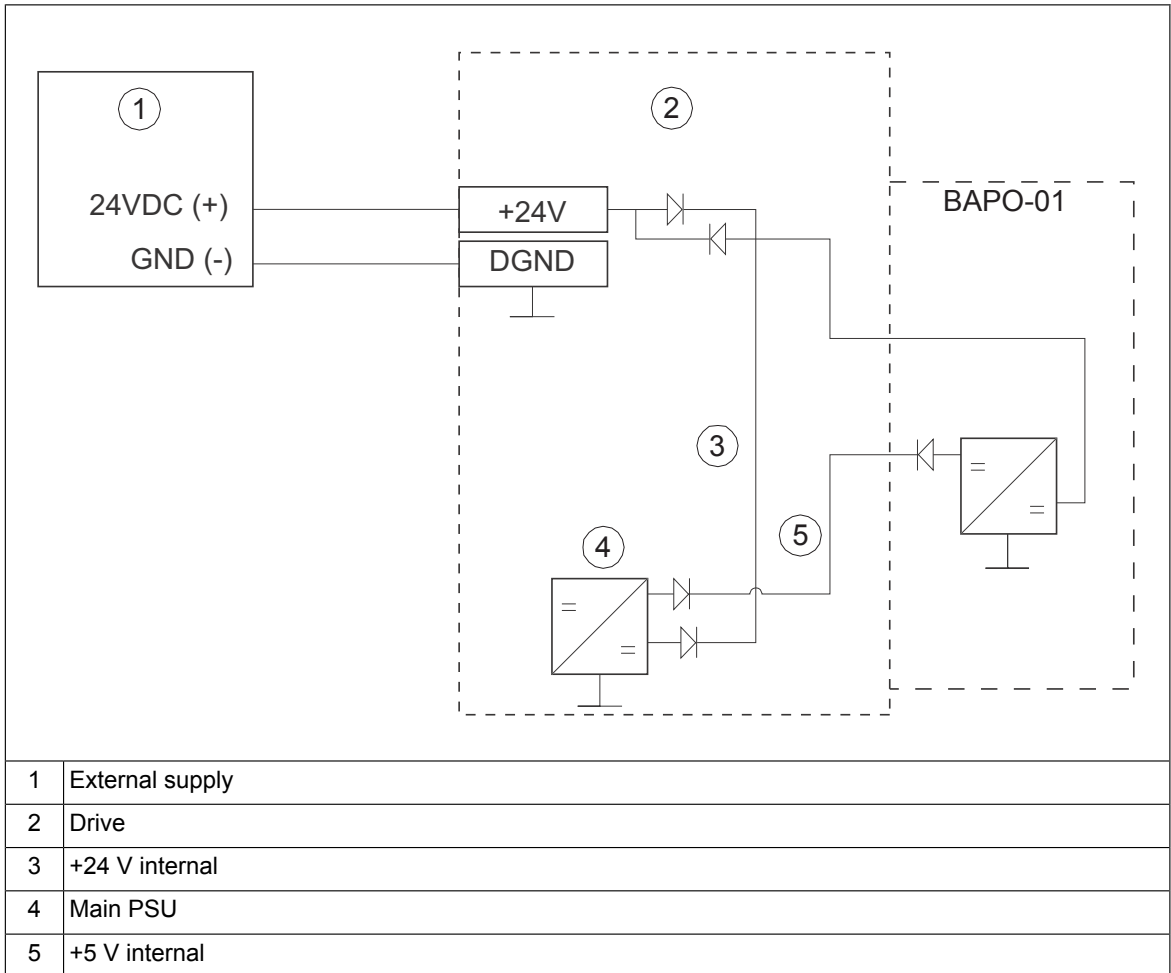

Power supply inside BAPO-01 works alongside the main power supply of the drive and only kicks in when the main power supply shuts down.

Option modules

The drive has 2 option slots:

- Front option: Slot 1 and 2 under the front cover.
- Side option: Slot on the side of the drive for BAPO-01 power extension module.
- Option slot 1
- Option slot 2

You can install the following optional modules in these option slots:

Module	Option slot	Applicable frames
Power extension - BAPO-01	Side option slot	R0...R2
Power extension - CMOD-2	Front option slot 2	R3...R5
I/O extension - BIO-01	Front option slot 1	R0...R2
Fieldbus (In R0...R2 frames, fieldbus module can be also used with BIO-01 module)	Front option slot1	R0...R8

■ **To install a front option**



WARNING!

Obey the instructions in chapter *Safety instructions (page 13)*. If you ignore them, injury or death, or damage to the equipment can occur.

Before you start the work, stop the drive and do the steps in section *Electrical safety precautions (page 16)*.

Front option slot 1

By default, RIIO-01 module is provided in ACS560 standard R0...R2 drives. You can remove the RIIO-01 module and can install BIO-01 and/or fieldbus adapter module (+fxxx). If you are installing any of the fieldbus module, see section *Routing the cables* for suitable connector types.

For information on BIO-01 option, see *BIO-01 I/O extension module (page 177)*.

Note:

BIO-01 module is applicable only for R0...R2 frame sizes.

To install RIIO-01, BIO-01 or/and fieldbus module, perform the following steps

1. Remove the front cover(s). See section *Connection procedure: frames R0...R2 (page 75)*.
If you have the BIO-01 option module, you can add a fieldbus option module on top of it. For more information see *BIO-01 I/O extension module (page 177)*.
2. For RIIO-01, pull the plastic locking tab of the optional module that you want to install.
3. Align the module with the option module slot in the front of the drive.
4. Push the option module into position.

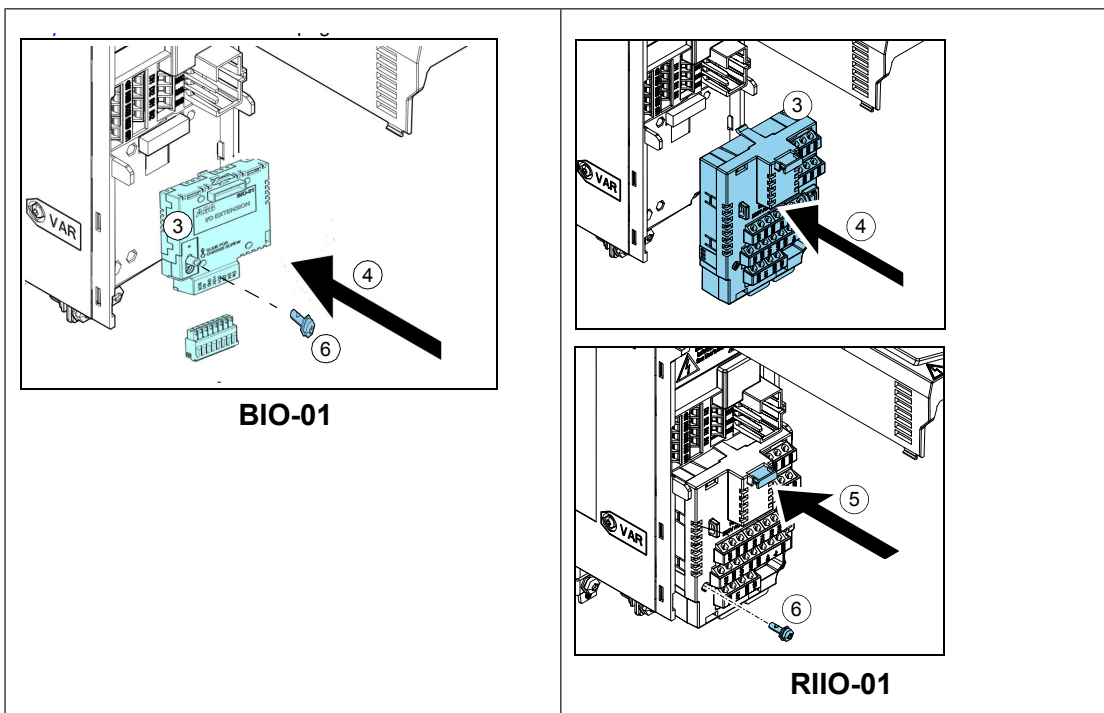

5. For RIIO-01, push the plastic locking tab down until it locks.
6. Tighten the locking screw.

Note:

The optional fieldbus module can also be installed on top of the BIO-01 module. See [BIO-01 I/O extension module \(page 177\)](#).

7. For BIO-01, connect the applicable control cables. See [Electrical installation \(page 179\)](#).

Front option slot 2 (applicable for R3...R5 frames)

In option slot 2 you can install power extension module CMOD-02 for additional external 24V power supply.

To install, perform the following steps

1. Remove the front cover(s). See section [Connection procedure, frames R3...R4 \(page 79\)](#) and [Connection procedure, frames R5...R8 \(page 83\)](#).
2. Put the module carefully into its position on the control board.
3. Tighten the mounting screw.
4. Tighten the grounding screw (CHASSIS).

Note:

The screw tightens the connections and grounds the module. It is necessary for fulfilling the EMC requirements and for proper operation of the module.



Note:

The CMOD-01 in the figure is for representation only. ACS560 supports only CMOD-02 module.

■ **To remove a front option**

1. Loosen the locking screw.
2. Pull the locking tab out to unlock the option module.
3. Pull the option module to disconnect and remove it.

Note:

The option module can be tightly in position.

■ **To install a side option**

1. Remove the two screws from the frontmost grounding clamp at the bottom of the drive.
2. Carefully align the side option with the connectors on the right side of the drive.
3. Fully push the option module into position.

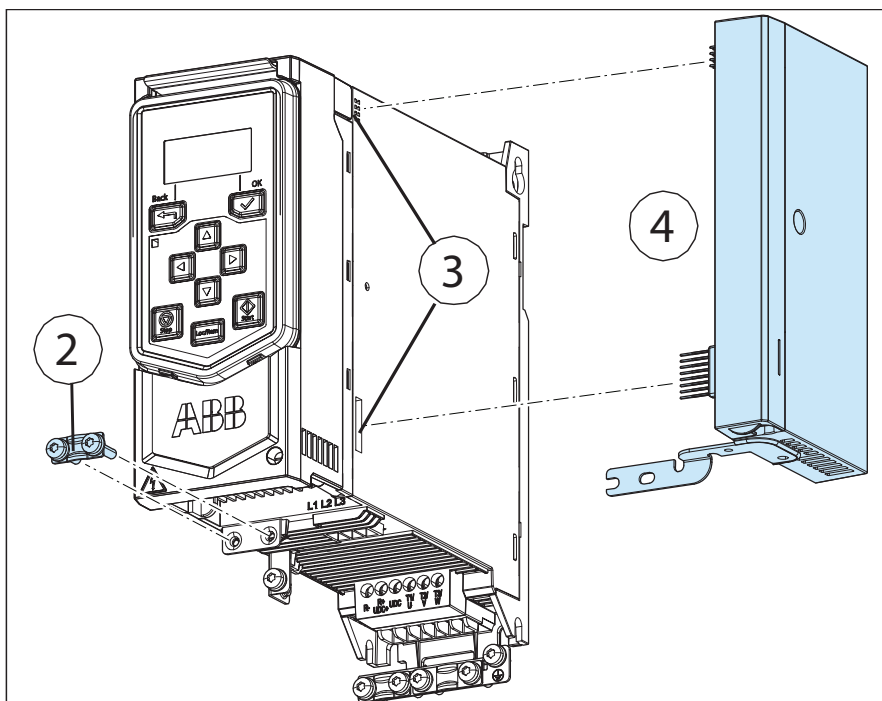

4. Tighten the locking screw of the option module.
5. Attach the grounding bar to the bottom of the side option and to the front ground tab on the drive.
6. Connect the applicable control cables according to [Connecting the control cables \(page 87\)](#).

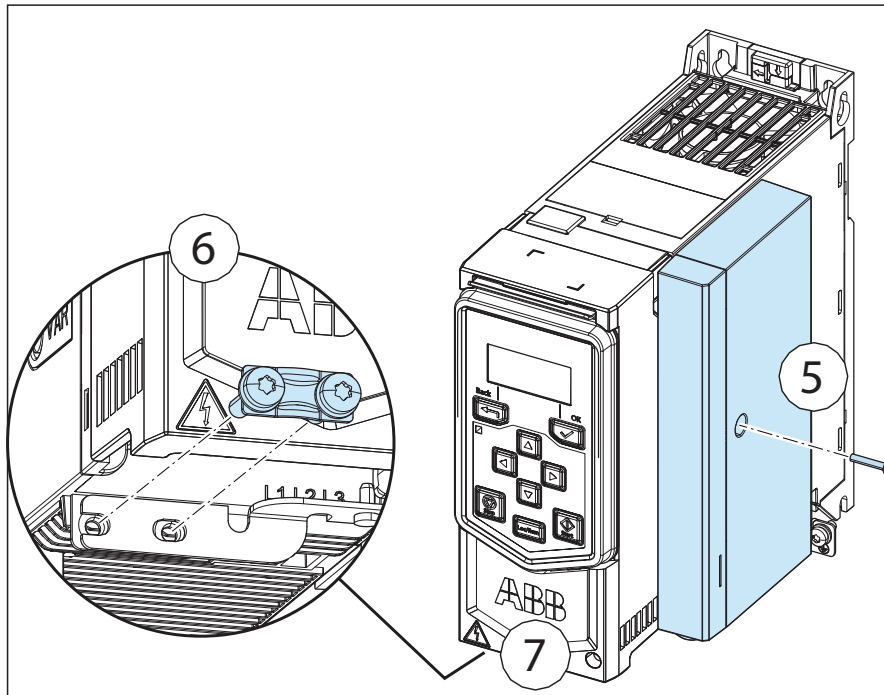

■ To remove a side option

1. Disconnect the control cables from the side option.
2. Open the grounding bar screws.
3. Loosen the locking screw.

Carefully remove the side option from the drive. Note that the option module can be tightly in position.

■ Wiring the modules

See the appropriate optional module manual for specific installation and wiring instructions.

Reinstalling covers

■ Reinstalling cover, frames size R0...R2

1. Reinstall the cover.
2. Tighten the retaining screw at the bottom with a screwdriver.



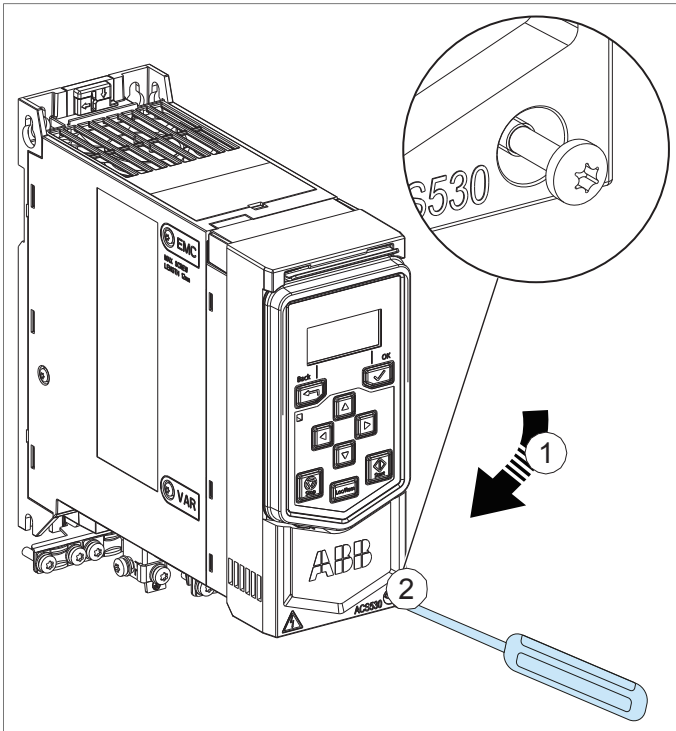

■ Reinstalling covers, frame size R3, R4

1. Reinstall the module cover. Put the tabs on the cover top in their counterparts on the housing and then press the cover. (1a.1b).
2. Tighten the two retaining screws with a screwdriver.

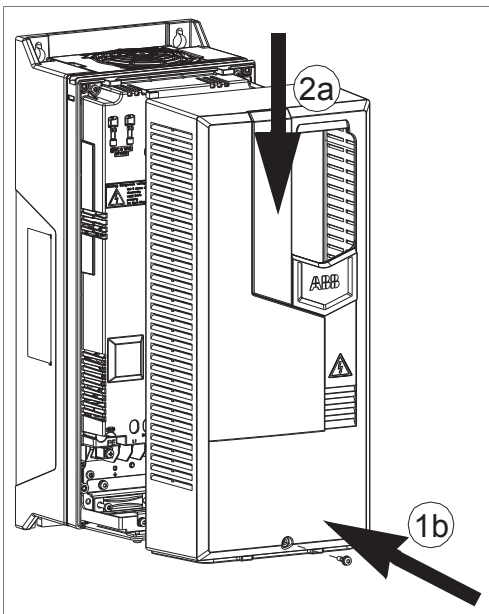

■ Reinstalling side plates and covers, frames size R5...R8

1. Reinstall the module cover. Put the tabs on the cover top in their counterparts on the housing and then press the cover.
2. Tighten the two retaining screws with a screwdriver.

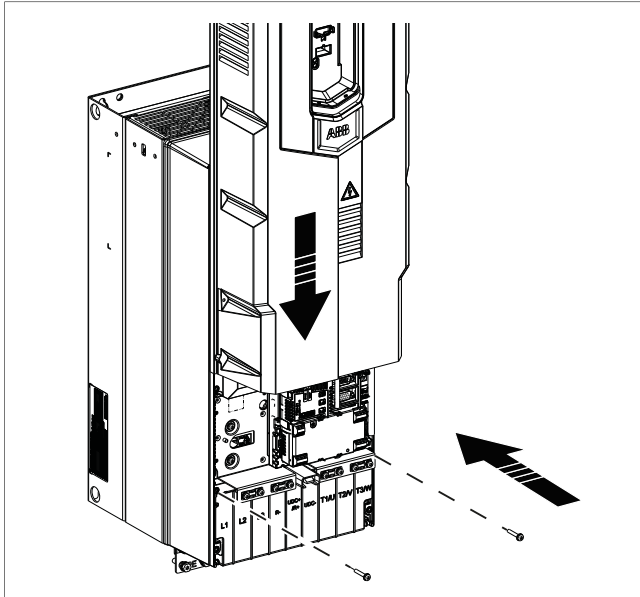

Connecting a PC

To connect a PC to the drive, there are two alternatives:

- Use an ACS-AP-I/S assistant control panel as a converter with a USB Mini-B type cable.
 1. Lift the USB connector cover from bottom upwards.
 2. Put the USB cable Mini-B plug in the control panel USB connector.
 3. Put the USB cable A-plug in the USB connector of the PC (3a). The panel displays text "USB connected" (3b).

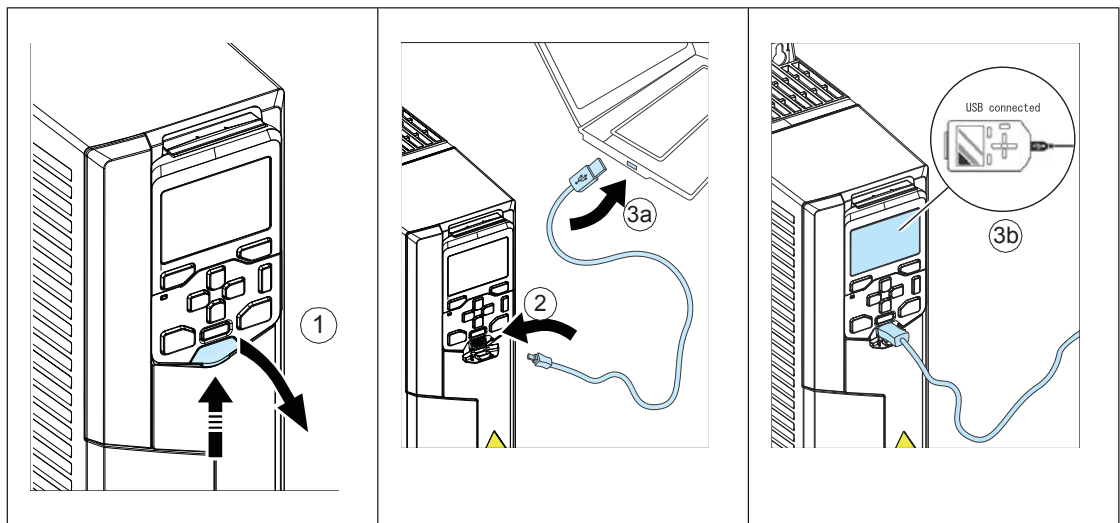

- Use a USB to RJ45 converter BCBL-01 (3AXD50000032449) with RDUM-01 (3AXD50000040850). You can order it from ABB.

Note:

Panel keys cannot be used when a USB data cable is connected to the panel.

For information on the Drive composer PC tool, refer to *Drive composer PC tool user's manual* (3AUA0000094606 [English]).





Installation checklist of the drive

Contents of this chapter

This chapter contains a checklist of the mechanical and electrical installation of the drive.

Checklist

Examine the mechanical and electrical installation of the drive before start-up. Go through the checklist together with another person.



WARNING!

Obey the safety instructions of the drive. If you ignore them, injury or death, or damage to the equipment can occur.

If you are not a qualified electrician, do not do installation or maintenance work.



WARNING!

Stop the drive and do the steps in section [Electrical safety precautions \(page 16\)](#) before you start the work.

Make sure that ...	<input checked="" type="checkbox"/>
The ambient operating conditions (including free space around the drive) meet the specifications.	<input type="checkbox"/>
The drive has been attached securely on an even, vertical and non-flammable wall.	<input type="checkbox"/>
The cooling air flows freely in and out of the drive.	<input type="checkbox"/>
<u>If the drive is connected to a network other than a symmetrically grounded TN-S system:</u> Check the compatibility. See the electrical installation instructions. See the electrical installation instructions in the supply unit manual.	
Appropriate AC fuses and main disconnectors have been installed.	<input type="checkbox"/>

108 Installation checklist of the drive

Make sure that ...	<input checked="" type="checkbox"/>
There is an adequately sized protective earth (ground) conductor between the drive and the switchboard, and the conductor has been connected to appropriate terminal, and the terminal has been tightened. (Pull on the conductor to check.) Proper grounding has also been measured according to the regulations.	<input type="checkbox"/>
The input power cable has been connected to the appropriate terminals, the phase order is right, and the terminals have been tightened. (Pull on the conductors to check.)	<input type="checkbox"/>
There is an adequately sized protective earth (ground) conductor between the motor and the drive, and the conductor has been connected to appropriate terminal, and the terminal has been tightened. (Pull on the conductors to check.). Proper grounding has also been measured according to the regulations.	<input type="checkbox"/>
The motor cable has been connected to the appropriate terminals, the phase order is right, and the terminals have been tightened. (Pull on the conductors to check.)	<input type="checkbox"/>
The motor cable has been routed away from other cables.	<input type="checkbox"/>
No power factor compensation capacitors have been connected to the motor cable.	<input type="checkbox"/>
The control cables have been connected to the appropriate terminals, and the terminals have been tightened. (Pull on the conductors to check.)	<input type="checkbox"/>
The supply voltage matches the nominal input voltage of the drive. Check the type designation label.	<input type="checkbox"/>
<u>If a drive bypass connection will be used:</u> The direct-on-line contactor of the motor and the drive output contactor are either mechanically or electrically interlocked, ie, cannot be closed simultaneously.	<input type="checkbox"/>
There are no tools, foreign objects or dust from drilling inside the drive.	<input type="checkbox"/>
The area in front of the drive is clean: the drive cooling fan cannot draw any dust or dirt inside.	<input type="checkbox"/>
Drive covers and cover of the motor connection box are in place.	<input type="checkbox"/>
The motor and the driven equipment are ready for start.	<input type="checkbox"/>



Maintenance and hardware diagnostics

Contents of this chapter

The chapter contains preventive maintenance instructions and LED indicator descriptions.

Maintenance intervals

The table below shows the maintenance tasks which can be done by the end user. The complete maintenance schedule is available on the Internet (www.abb.com/driveservices). For more information, consult your local ABB Service representative (www.abb.com/searchchannels).

Maintenance and component replacement intervals are based on the assumption that the equipment is operated within the specified ratings and ambient conditions. ABB recommends annual drive inspections to ensure the highest reliability and optimum performance.

Note:

Long term operation near the specified maximum ratings or ambient conditions may require shorter maintenance intervals for certain components. Consult your local ABB Service representative for additional maintenance recommendations.

■ Description of symbols

Action	Description
I	Visual Inspection and maintenance action if needed
P	Performance of on/off-site work (commissioning, tests, measurements or other work)
R	Replacement of component

Symbols

- I** **Inspection**, maintenance action if needed
- (I)** Inspection in harsh conditions, maintenance action if needed
- R** **Replacement**
- (R)** Replacement in harsh conditions
- O** **Other work** (commissioning, tests, measurements, etc.)

* Ambient temperature constantly over 40 °C, especially dusty or humid ambient conditions, cyclic heavy load, or continuous rated (full) load.

To maintain the best possible performance and reliability of the drive, inspect the drive annually. Contact ABB Service at least once in three years for replacement of aging components.

Note:

Recommended maintenance intervals and component replacements are based on operation in specified ambient conditions.

Heatsink

The drive heatsink fins pick up dust from the cooling air. The drive can run into overtemperature warnings and faults if the heatsink is not clean. When necessary, clean the heatsink as follows:



WARNING!

Obey the instructions in chapter *Safety instructions (page 13)*. Ignoring the instructions can cause physical injury or death, or damage to the equipment.



WARNING!

Use a vacuum cleaner with antistatic hose and nozzle. Using a normal vacuum cleaner creates static discharges which can damage circuit boards.

1. Stop the drive and disconnect it from the power line. Wait for 5 minutes and then make sure by measuring that there is no voltage. See section *Electrical safety precautions (page 16)* before you start the work.
2. Remove the cooling fan(s). See section *Electrical safety precautions (page 16)*.
3. Blow clean, dry and oil free compressed air from bottom to top and simultaneously use a vacuum cleaner at the air outlet to trap the dust.

Note:

If there is a risk of dust entering adjoining equipment, perform the cleaning in another room.

4. Reinstall the cooling fan(s).

Fans

See section *Maintenance intervals (page 109)* for the fan replacement interval in average operation conditions.

In a speed-controlled fan, the speed of the fan matches the cooling needs. This increases the life span of the fan.

Replacement fans are available from the manufacturer. Do not use other than specified spare parts.

■ Replacing the cooling fan, frames size R0...R4



WARNING!

Obey the instructions in chapter [Safety instructions \(page 13\)](#). Ignoring the instructions can cause physical injury or death, or damage to the equipment.

1. Stop the drive and disconnect it from the power line. Wait for 5 minutes and then make sure by measuring that there is no voltage. See section [Electrical safety precautions \(page 16\)](#) before you start the work.
2. Lever the fan assembly off the drive frames with for example a screwdriver (2a), and pull out the fan assembly (2b).
3. Unplug fan power supply wires from the drive.
4. Install the fan assembly in reverse order.

R0...R2

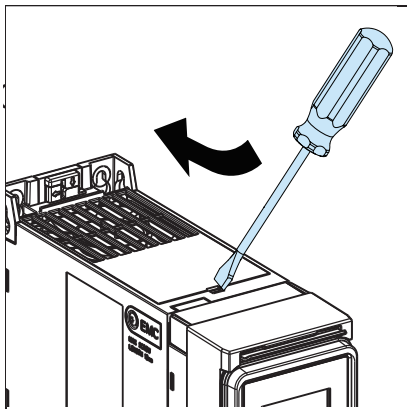

R3...R4

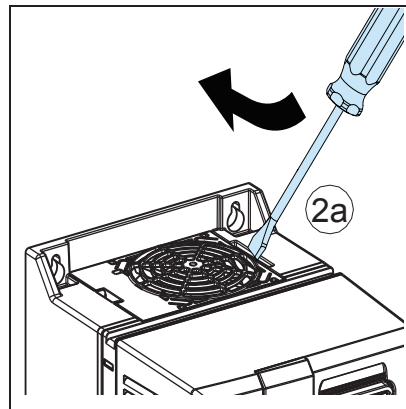

R0...R2

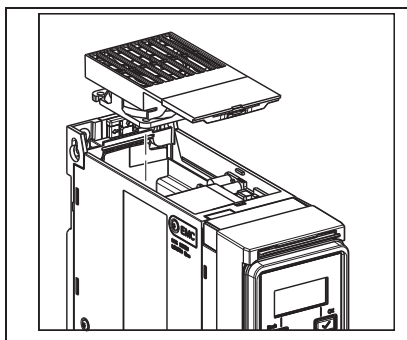

R3...R4

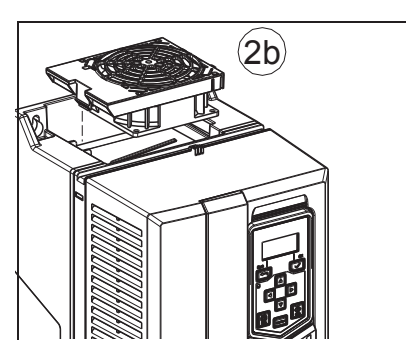

■ Replacing the main cooling fan, frame R5



WARNING!

Obey the instructions in chapter [Safety instructions \(page 13\)](#). Ignoring the instructions can cause physical injury or death, or damage to the equipment.

1. Stop the drive and disconnect it from the power line. Wait for 5 minutes and then make sure by measuring that there is no voltage. See section [Electrical safety precautions \(page 16\)](#) before you start the work.
2. Lift the fan assembly upwards from the front edge (2a) and remove the assembly (2b).
3. Unplug fan power supply wires from the drive.

4. Install the new fan assembly in reverse order.

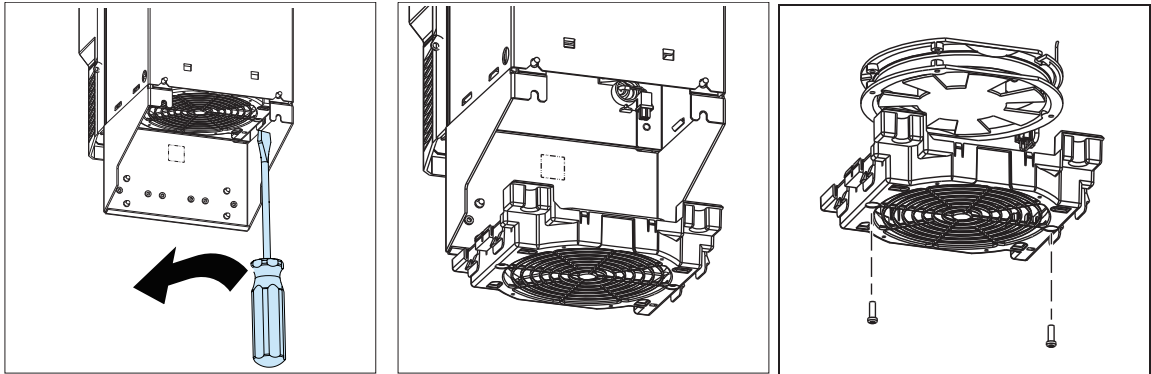

■ Replacing the main cooling fan, frames size R6...R8



WARNING!

Obey the instructions in chapter [Safety instructions \(page 13\)](#). Ignoring the instructions can cause physical injury or death, or damage to the equipment.

1. Stop the drive and disconnect it from the power line. Wait for 5 minutes and then make sure by measuring that there is no voltage. See section [Electrical safety precautions \(page 16\)](#) before you start the work.
2. Remove the two mounting screws of the fan mounting plate at the bottom of the drive.
3. Pull the fan mounting plate down from the side edge.
4. Unplug fan power supply wires from the drive.
5. Lift the fan mounting plate off.
6. Remove the fan from the mounting plate.
7. Install the new fans in reverse order.

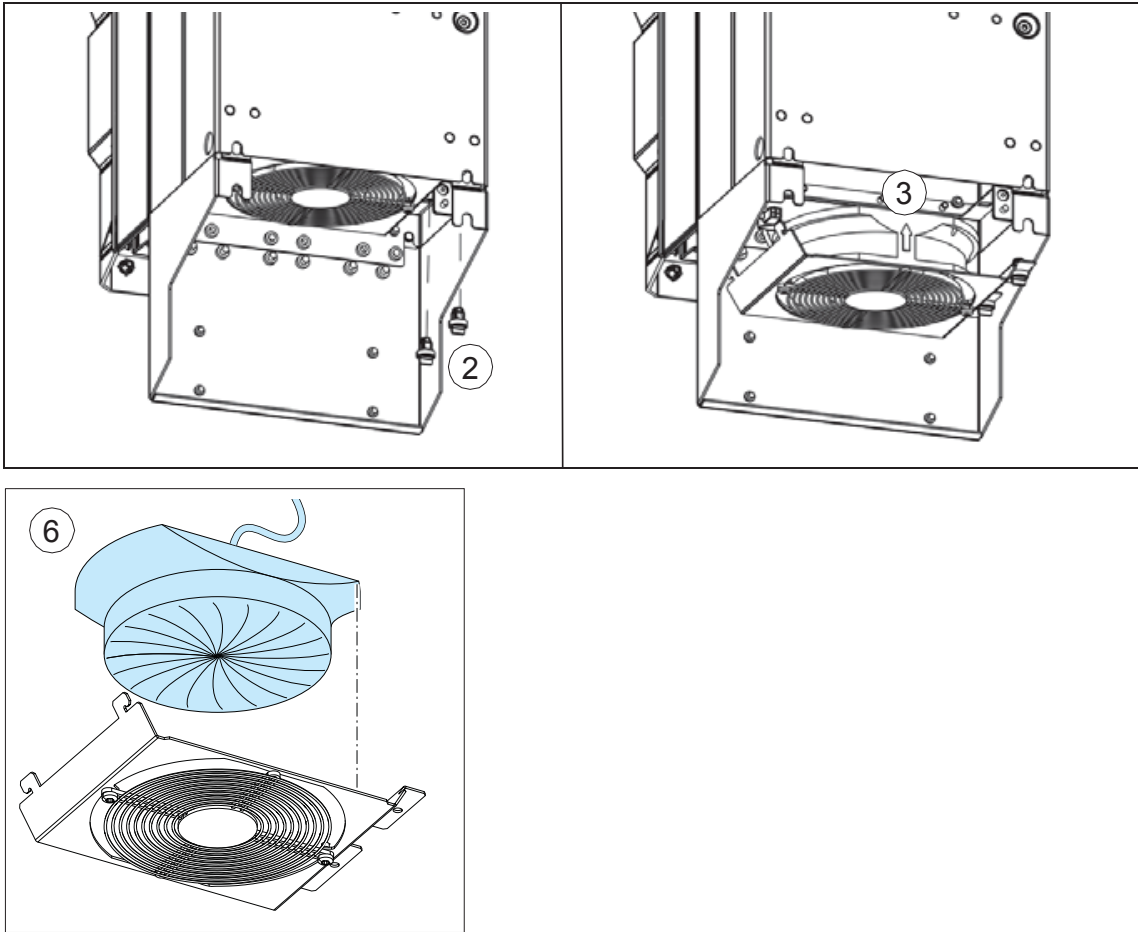

■ Replacing the auxiliary cooling fan, frames R6...R8



WARNING!

Obey the instructions in chapter *Safety instructions (page 13)*. Ignoring the instructions can cause physical injury or death, or damage to the equipment.

1. Stop the drive and disconnect it from the power line. Wait for 5 minutes and then make sure by measuring that there is no voltage. See section *Electrical safety precautions (page 16)* before you start the work.
2. Remove the front cover (see *Installing the drive vertically, frames size R5...R8 (page 50)*).
3. Unplug fan power supply wires from the drive.
4. Release the retaining clips.
5. Lift the fan off.
6. Install the new fan in reverse order. Make sure that the arrow on the fan points up.

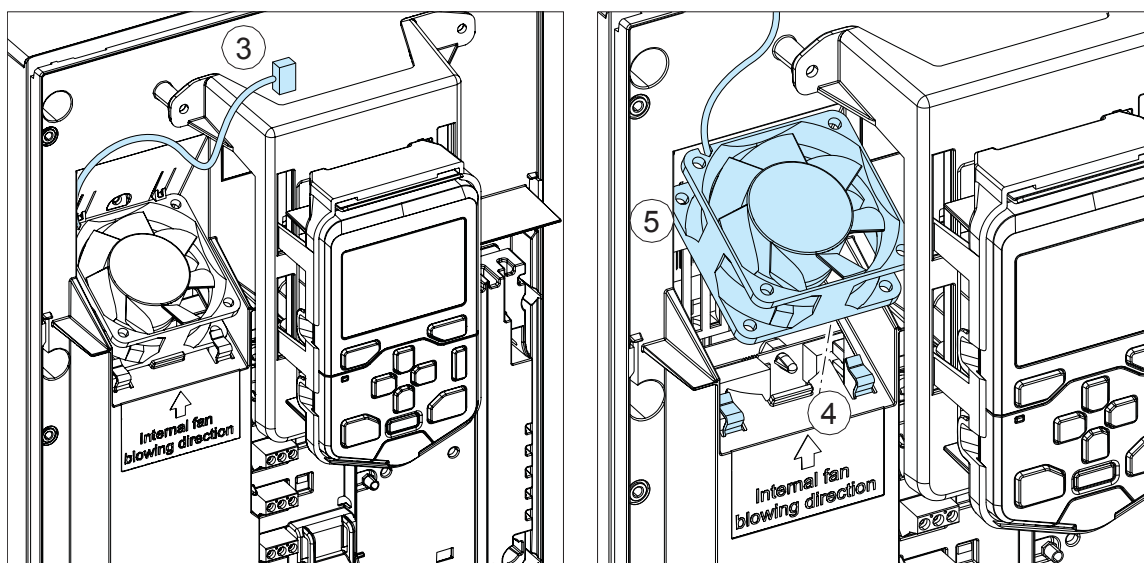

Capacitors

The drive intermediate DC circuit employs several electrolytic capacitors. Their lifespan depends on the operating time of the drive, loading and ambient temperature. Capacitor life can be prolonged by lowering the ambient temperature.

Capacitor failure is usually followed by damage to the drive and an input cable fuse failure, or a fault trip. Contact the manufacturer if capacitor failure is suspected. Replacements are available from the manufacturer. Do not use other than specified spare parts.

■ Reforming the capacitors

The capacitors must be reformed if the drive has not been powered (either in storage or unused) for a year or more. See section *Type designation label (page 37)* for how to find out the manufacturing date from the serial number.

For information on reforming the capacitors, see *Converter module capacitor reforming instructions* (3BFE64059629 [English]), available on the Internet (go to <http://www.abb.com> and enter the code in the Search field).

Control panel

■ Cleaning the control panel

Use a soft damp cloth to clean the control panel. Avoid harsh cleaners which could scratch the display window.

■ Replacing the battery in the control panel

A battery is only used in the assistant control panel that support the clock function. The battery keeps the clock operating in memory during power interruptions.

The expected life for the battery is greater than ten years.

Note:

The battery is NOT required for any control panel or drive functions, except the clock.

1. Remove the control panel from the drive. See section *Control panel (page 36)*.

2. To remove the battery, use a coin to rotate the battery cover on the back of the control panel.
3. Replace the battery with type CR2032. Dispose the old battery according to local disposal rules or applicable laws.

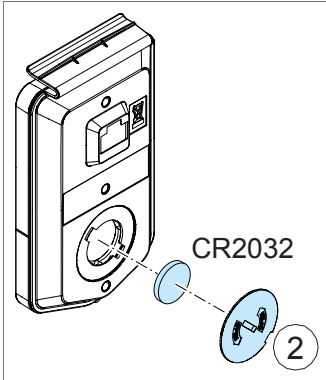

LEDs

■ Drive LEDs (R3~R8)

There is a green POWER and a red FAULT LED on the front of the drive. They are visible through the panel cover but invisible if a control panel is attached to the drive. The table below describes the drive LED indications.

Drive LEDs POWER and FAULT, on the front of the drive, under the control panel / panel cover If a control panel is attached to the drive, switch to remote control (otherwise a fault will be generated), and then remove the panel to be able to see the LEDs				
LEDs off	LED lit and steady		LED blinking	
No power	Green (POWER)	Power supply on the board OK	Green (POWER)	<u>Blinking:</u> Drive in an alarm state <u>Blinking for one second:</u> Drive selected on the control panel when multiple drives are connected to the same panel bus.
	Red (FAULT)	Active fault in the drive. To reset the fault, press RESET from the control panel or switch off the drive power.	Red (FAULT)	Active fault in the drive. To reset the fault, switch off the drive power.

■ Control panel LEDs

The basic control panel has one LED. The table below describes the control panel LED indications. For more information see ACS-BP-S basic control panel user manual (3AXD50000032527 [English]).

Control panel LED, at the left edge of the control panel				
LED off	LED lit and steady		LED blinking/flickering	
Panel has no power.	Green	Drive functioning normally. Connection between the drive and control panel may be faulty or lost, or the panel and drive may be incompatible. Check the control panel display.	Green	<u>Blinking:</u> Active warning in the drive <u>Flickering:</u> Data transferred between the PC tool and drive through the USB connection of the control panel
	Red	Check the display to see where the fault is. <ul style="list-style-type: none"> • Active fault in the drive. Reset the fault. • Active fault in another drive in the panel bus. Switch to the drive in question and check and reset the fault. 	Red	Active fault in the drive. To reset the fault, cycle the drive power.

9

Technical data

Contents of this chapter

The chapter contains the technical specifications of the drive, for example ratings, sizes and technical requirements as well as provisions for fulfilling the requirements for CE, UL and other approval marks.

Ratings

■ IEC ratings

Drive Type ACS380	Nominal In	Max. current	Output ratings									Frame size
			Nominal use			Light overload use			Heavy-duty use			
			I_N	P_N		I_{Ld} (Continuous)	P_{Ld}		I_{Hd} (Continuous)	P_{Hd}		
A	A	A	kW	Hp	A	kW	Hp	A	kW	Hp		
3 phases $U_N = 400$ V (380...415 V)												
02A6-4	2.6	3.2	2.6	0.75	1	2.5	0.75	1	1.8	0.55	0.75	R0
03A3-4	3.3	4.7	3.3	1.1	1.5	3.1	1.1	1.5	2.6	0.75	1	R0
04A0-4	4	5.9	4	1.5	2	3.8	1.5	2	3.3	1.1	1.5	R0
05A6-4	5.6	7.2	5.6	2.2	3	5.3	3	3	4	1.5	2	R0

Drive Type ACS800	Nominal In	Max. current	Output ratings									Frame size
			Nominal use			Light overload use			Heavy-duty use			
			I_N	P_N		I_{Ld} (Continuous)	P_{Ld}		I_{Hd} (Continuous)	P_{Hd}		
A	A	A	kW	Hp	A	kW	Hp	A	kW	Hp		
07A2-4	7.2	10.1	7.2	3	4	6.8	2.2	4	5.6	2.2	3	R0
09A4-4	9.4	13	9.4	4	5	8.9	4	5	7.2	3	4	R0
12A6-4	12.6	16.9	12.6	5.5	7.5	12	5.5	7.5	9.4	4	5	R1
017A-4	17	22.7	17	7.5	10	16.2	7.5	10	12.6	5.5	7.5	R2
025A-4	25	30.6	25	11	15	23.8	11	15	17	7.5	10	R2
033A-4	33	44.3	33	15	20	30.4	15	20	24.6	11	15	R3
039A-4	39	56.9	39	18.5	25	36.1	18.5	25	31.6	15	20	R3
046A-4	46	67.9	46	22	30	42.8	22	30	37.7	18.5	25	R3
062A-4	62	76	62	30	40	58	30	40	44.6	22	30	R4
073A-4	73	104	73	37	50	68.4	37	50	61	30	40	R4
088A-4	88	122	88	45	60	82.7	45	60	72	37	50	R5
106A-4	106	148	106	55	75	99.8	55	75	87	45	60	R5
145A-4	145	178	145	75	100	138	75	100	105	55	75	R6
169A-4	169	247	169	90	120	161	90	120	145	75	100	R7
206A-4	206	287	206	110	150	196	110	150	169	90	120	R7
246A-4	246	350	246	132	180	234	132	180	206	110	150	R8
293A-4	293	418	293	160	215	278	160	215	246 ¹⁾	132	180	R8

3AXD10000561047.xls A

¹⁾ Continuous current when its used in Heady duty applications, allows 130% of IHd for 1 minute every 10 minutes at 40 °C.

See definitions and notes in section *Definitions (page 121)*.

■ Definitions

U_N	Nominal voltage
I_1	Nominal input current (rms) at 40 °C (104 °F)
I_{max}	Maximum output current. Available for two seconds at start.
I_N	Nominal output current. Maximum continuous rms output current allowed (no overload).
P_N	Nominal power of the drive. Typical motor power (no overloading). The kilowatt ratings apply to most IEC 4-pole motors. The horsepower ratings apply to most NEMA 4-pole motors.
I_{Ld}	Maximum current with 110% overload, allowed for one minute every ten minutes
P_{Ld}	Typical motor power in light-duty use (110% overload)
I_{Hd}	Maximum current with 150% overload, allowed for one minute every ten minutes
P_{Hd}	Typical motor power in heavy-duty use (150% overload)

■ Sizing

Drive sizing is based on the rated motor current and power. To achieve the rated motor power given in the table, the rated current of the drive must be higher than or equal to the rated motor current. Also the rated power of the drive must be higher than or equal to compared to the rated motor power. The power ratings are the same regardless of the supply voltage within one voltage range.

Note:

The nominal values of I_N apply to the ambient temperature of 40°C (104°F). Derating is needed above this temperature for R3...R8 frames.

Derating

The load capacity (I_N , I_{Ld} , I_{Hd} ; note that I_{max} is not derated) decreases for certain situations, as defined below. In such situations, where full motor power is required, oversize the drive so that the derated value provides sufficient capacity.

Note:

If several situations are present at a time, the effect of derating for each situation is cumulative.

Example:

If your application requires continuous 12.0 A of motor current (I_N) at 8 kHz switching frequency, the supply voltage is 400 V and the drive is situated at 1500 m, calculate the appropriate drive size requirement as follows:

Switching frequency derating (page 122): The minimum size required is $I_N = 12.0 \text{ A} / 0.66 = 18.18 \text{ A}$, where 0.66 is the derating for 8 kHz switching frequency (frames R0...R3).

Altitude derating (page 123): The derating factor for 1500 m is $1 - 1/10\,000 \text{ m} \cdot (1500 - 1000) \text{ m} = 0.95$. The minimum size required becomes then $I_N = 18.18 \text{ A} / 0.95 = 19.14 \text{ A}$.

Referring to I_N in the ratings tables (starting from 119), drive type ACS560-01-025A-4 exceeds the I_N requirement of 19.24 A.

■ Ambient temperature derating, IP20

Frame size	Temperature range	Action
R0...R2	0...+50°C +32... +122°F	Derating not required
	+50...+55°C +122...131°F	Derating required
R3...R8	0...+40°C +32...+104°F	Derating not required
	+40...+55°C +104...+131°F	Derating required

The output current is calculated by the current given in the rating tables multiplying by the derating factor (k, as shown in the following figure)

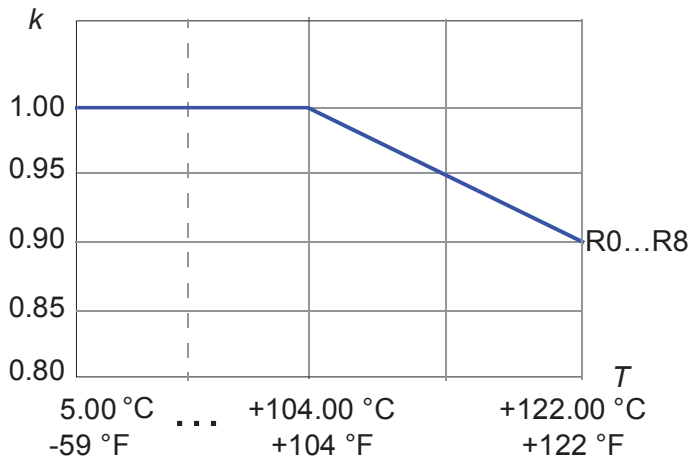

■ Switching frequency derating

The output current is calculated by multiplying the current given in the rating table by the derating factor given in the table below.

Note:

If you change the minimum switching frequency with parameter 97.02 Minimum switching frequency, derate according to the table below. Changing parameter 97.01 Switching frequency reference does not require derating.

Frame size	Derating factor of the min. switch frequency			
	2kHz	4kHz	8kHz	12kHz
R0	1	1	0.65	0.48
R1	1	1	0.67	0.5
R2	1	1	0.67	0.5
R3	1	1	0.65	0.48
R4	1	1	0.73	0.55

Frame size	Derating factor of the min. switch frequency			
	2kHz	4kHz	8kHz	12kHz
R5	1	1	0.71	0.55
R6	0.97	0.83	0.66	0.5
R7	0.98	0.88	0.7	0.5
R8	0.96	0.81	0.6	Not applicable

3AXD10000561047.xls

■ Altitude derating

In altitudes 1000...4000 m (3300...13120 ft) above sea level, the derating is 1% for every 100 m (330 ft).

The output current is calculated by multiplying the current given in the rating table by the derating factor k , which for x meters ($1000 \text{ m} \leq x \leq 4000 \text{ m}$) is:

$$k = 1 - \left(\frac{1}{10000m}\right) * (x - 1000)m$$

Check the network compatibility restrictions above 2000 m (6562 ft), see section [Installation site altitude \(page 139\)](#).

Fuses (IEC)

gG as well as uR or aR fuses for protection against short-circuit in the input power cable or drive are listed below. Either fuse type can be used for frames R0...R8 if it operates rapidly enough. The operating time depends on the supply network impedance and the cross-sectional area and length of the supply cable.

Note 1: See also [\(page 61\)](#).

Note 2: Fuses with higher current rating than the recommended ones must not be used.

Note 3: Fuses from other manufacturers can be used if they meet the ratings and the melting curve of the fuse does not exceed the melting curve of the fuse mentioned in the table.

■ uR and aR fuse

Drive type ACS560	Minimum short cir- cuit cur- rent ¹⁾	Input cur- rent	uR and aR				
			Rated cur- rent I_N	I^2t	Rated voltage	Bussmann designation type	IEC 60269 size
			A	A ² s	V		
3 phases $U_N = 400 \text{ V}$ (380...480 V)							
02A6-4	48	4.2	25	125	690	170M2694	00
03A3-4	48	5.3	25	125	690	170M2694	00
04A0-4	80	6.4	32	275	690	170M2695	00
05A6-4	80	9.0	32	275	690	170M2695	00
07A2-4	128	11.5	40	490	690	170M2696	00
09A4-4	128	15.0	40	1000	690	170M2696	00

Drive type ACS560	Minimum short cir- cuit cur- rent ¹⁾	Input cur- rent	uR and aR				
			Rated cur- rent I _N	I ² t	Rated voltage	Bussmann designation type	IEC 60269 size
			A	A ² s	V		
12A6-4	200	20.2	50	1800	690	170M2697	00
017A-4	256	27.2	63	3600	690	170M2698	00
025A-4	400	40.0	80	1450	690	170M2699	00
033A-4	170	32.0	63	1450	690	170M1565	000
039A-4	170	38.0	63	2550	690	170M1565	000
046A-4	280	45.0	80	4650	690	170M1566	000
062A-4	380	62.0	100	8500	690	170M1567	1
073A-4	480	73.0	125	16000	690	170M1568	000
088A-4	480	88.0	160	15000	690	170M1569	1
106A-4	700	106.0	200	28500	690	170M3815	1
145A-4	1000	145.0	250	46500	690	170M3816	1
169A-4	1280	169.0	315	68500	690	170M3817	1
206A-4	1520	206.0	350	105000	690	170M3818	1
246A-4	2050	246.0	450	145000	690	170M5809	2
293A-4	2200	293.0	500	275000	690	170M5810	2

¹⁾ minimum short-circuit current of the device

3AXD10000561047.xls A

■ gG fuses

Drive type ACS560	Minimum short cir- cuit cur- rent ¹⁾	Input cur- rent	gG (IEC 60269)				
			Rated cur- rent I _N	I ² t	Rated voltage	ABB designa- tion type	IEC 60269 size
			A	A ² s	V		
3 phases U_N = 400 V (380...480 V)							
02A6-4	48	4.2	6	110	500	OFAF000H6	000
03A3-4	48	5.3	6	110	500	OFAF000H6	000
04A0-4	80	6.4	10	360	500	OFAF000H10	000
05A6-4	80	9.0	10	360	500	OFAF000H10	000
07A2-4	128	11.5	16	740	500	OFAF000H16	000
09A4-4	128	15.0	16	740	500	OFAF000H16	000
12A6-4	200	20.2	25	2500	500	OFAF000H25	000
017A-4	256	27.2	32	4500	500	OFAF000H32	000

Drive type ACS560	Minimum short cir- cuit cur- rent ¹⁾	Input cur- rent	gG (IEC 60269)				
			Rated cur- rent I _N	I ² t	Rated voltage	ABB designa- tion type	IEC 60269 size
			A	A ² s	V		
025A-4	320	40.0	50	15500	500	OFAF000H50	000
033A-4	320	33.0	40	7700	500	OFAF000H40	000
039A-4	400	39.0	50	16000	500	OFAF000H50	000
046A-4	500	45.0	63	20100	500	OFAF000H63	000
062A-4	800	62.0	80	37500	500	OFAF000H80	000
073A-4	1000	73.0	100	65000	500	OFAF000H100	000
088A-4	1000	88.0	100	65000	500	OFAF000H100	000
106A-4	1300	106.0	125	103000	500	OFAF000H125	00
145A-4	1700	145.0	160	185000	500	OFAF000H160	00
169A-4	3300	169.0	250	600000	500	OFAF000H250	0
206A-4	5500	206.0	315	710000	500	OFAF000H315	1
246A-4	6400	246.0	355	920000	500	OFAF000H355	1
293A-4	7800	293.0	425	1300000	500	OFAF000H425	2

¹⁾ minimum short-circuit current of the device

3AXD10000561047.xls A

■ gR fuses

Drive type ACS560-	Minimum short cir- cuit cur- rent ¹⁾	Input cur- rent	gG (IEC 60269)				
			Rated cur- rent I _N	I ² t	Rated voltage	ABB designa- tion type	IEC 60269 size
			A	A ² s	V		
3-phase UN = 380...480 V							
02A6-4	48	4.2	25	125	690	170M2694	00
03A3-4	48	5.3	25	125	690	170M2694	00
04A0-4	80	6.4	32	275	690	170M2695	00
05A6-4	80	9.0	32	275	690	170M2695	00
07A2-4	128	11.5	40	490	690	170M2696	00
09A4-4	128	15.0	40	490	690	170M2696	00
12A6-4	200	20.2	50	1000	690	170M2697	00
017A-4	256	27.2	63	1800	690	170M2698	00
025A-4	400	40.0	80	3600	690	170M2699	00
033A-4	170	32.0	63	1450	690	170M1565	000

Drive type ACS560-	Minimum short cir- cuit cur- rent ¹⁾	Input cur- rent	gG (IEC 60269)				
			Rated cur- rent I _N	I ² t	Rated voltage	ABB desig- nation type	IEC 60269 size
			A	A ² s	V		
039A-4	170	38.0	63	1450	690	170M1565	000
046A-4	280	45.0	80	2550	690	170M1566	000
062A-4	380	62	100	4650	690	170M1567	000
073A-4	480	73	125	8500	690	170M1568	000
088A-4	480	88	160	16000	690	170M1569	000
106A-4	700	106	200	15000	690	170M3815	1
145A-4	1000	145	250	28500	690	170M3816	1
169A-4	1280	169	315	46500	690	170M3817	1
206A-4	1520	206	350	68500	690	170M3818	1
246A-4	2050	246	450	105000	690	170M5809	2
293A-4	2200	293	500	145000	690	170M5810	2

¹⁾ minimum short-circuit current of the device

3AXD10000561047.xls A

Circuit breakers

The table below lists MCB circuit breakers that can be used with the drive.

Type ACS560	MCBs					
	ABB type	Max. short-circuit	Tmax frame XT / T class	Tmax rating	Electronic release	SACE ordering code for breaker and release unit
		I_{sc}				
		kA				
3-phase $U_N = 380...480$ V						
02A6-4	S 203P-B/C/Z 10	20	N/A	N/A	N/A	N/A
03A3-4	S 203P-B/C/Z 10	20	N/A	N/A	N/A	N/A
04A0-4	S 203P-B/C/Z 10	20	N/A	N/A	N/A	N/A
05A6-4	S 203P-B/C/Z 10	20	N/A	N/A	N/A	N/A
07A2-4	S 203P-B/C/Z 10	20	N/A	N/A	N/A	N/A
09A4-4	S 203P-B/C/Z 10	20	N/A	N/A	N/A	N/A
12A6-4	S 203P-B/C/Z 16	20	N/A	N/A	N/A	N/A
017A-4	S 203P-B/C/Z 20	20	N/A	N/A	N/A	N/A
025A-4	S 203P-B/C/Z 25	20	N/A	N/A	N/A	N/A
033A-4	S 203P-B/C/Z 32	12	N/A	N/A	N/A	N/A
039A-4	S 203P-B/C/Z 40	12	N/A	N/A	N/A	N/A
046A-4	S 203P-B/C/Z 50	12	N/A	N/A	N/A	N/A
062A-4	S 803S-B/C 80	50	N/A	N/A	N/A	N/A
073A-4	S 803S-B/C 80	50	N/A	N/A	N/A	N/A
088A-4	S 803S-B/C 100	50	N/A	N/A	N/A	N/A
106A-4	S 803S-B/C 125	50	N/A	N/A	N/A	N/A
145A-4	XT4 L 250 Ekip LS/I In=250 3p F F	65	XT4	250	250	1SDA068555R1
169A-4	XT4 L 250 Ekip LS/I In=250 3p F F	65	XT4	250	250	1SDA068555R1
206A-4	T4 L 320 PR221DS-LS/I In=320 3p F F	65	T4	320	320	1SDA054141R1
246A-4	T5 L 400 PR221DS-LS/I In=400 3p F F	65	T5	400	400	1SDA054365R1
293A-4	T5 L 630 PR221DS-LS/I In=630 3p F F	65	T5	630	630	1SDA054420R1

Dimensions, weights and free space requirements

Frame size	Dimensions and weight				
	IP20				
	W	D	H1	H2	Weight
	mm	mm	mm	mm	kg
R0	73	207	223	x	1.6
R1	97	207	223	x	1.9
R2	172	207	220	x	2.9
R3	203	229	490	x	14.9
R4	203	257	636	x	19
R5	203	296	719	600	28.3
R6	252	369	722	548	42.4
R7	284	371	839	600	54
R8	300	394	943	680	69

Standard frame size (R0-R8)

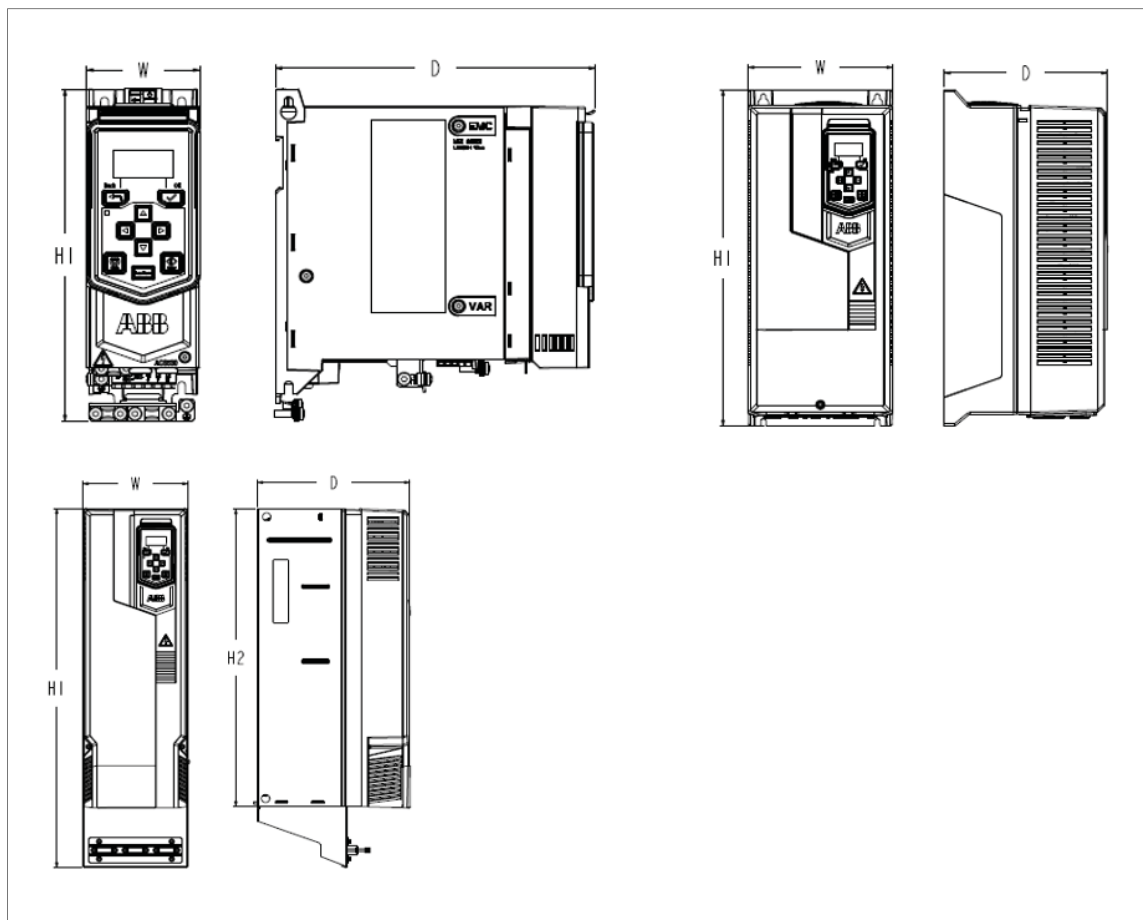

Symbols

IP20

H1 Height of front side

H2 Height of back side (without cable connecting box)

W Width

D Depth

Frame size	Free space				
	Vertical installation Independent		Vertical installation Side by side		
	Above	Below	Above	Below	Interval
	mm	mm	mm	mm	mm
R0	75	75	75	75	0
R1	75	75	75	75	0
R2	75	75	75	75	0
R3	200	200	200	200	0
R4	200	200	200	200	0
R5	200	300	200	300	0
R6	200	300	200	300	0
R7	200	300	200	300	0
R8	200	300	200	300	0

See the figures in section [Checking the installation site \(page 42\)](#).

Thermal losses, cooling data and noise

The air flow direction is from bottom to top.

The table below specifies the heat dissipation in the main circuit at nominal load and in the control circuit with minimum load (I/O, options and panel not in use) and maximum load (all digital inputs and relays in the ON state, and the panel, fieldbus and fan in use). The total heat dissipation is the sum of the heat dissipation in the main and control circuits. Use the maximum heat dissipation when designing cabinet or electrical room cooling needs.

Desig. ACS560	Thermal losses				Air flow	Noise	Frame size
	Main circuit nominal I_{1N} , I_N	Control circuit Min. load	Control circuit Max. load	Main circuit and control circuit Max. load			
	W	W	W	W	m ³ /h	dB(A)	
3 phases $U_N = 400V$ (380...480V)							
02A6-4	35	0.3	9	44	57	63.10	R0

Desig. ACS560	Thermal losses				Air flow	Noise	Frame size
	Main circuit nominal I_{1N} , I_N	Control circuit Min. load	Control circuit Max. load	Main circuit and control circuit Max. load			
	W	W	W	W	m ³ /h	dB(A)	
03A3-4	42	0.3	9	51	57	63.10	R0
04A0-4	50	0.3	9	59	57	63.10	R0
05A6-4	68	0.3	9	77	57	63.10	R0
07A2-4	88	0.3	9	97	57	63.10	R0
09A4-4	115	0.3	9	124	57	63.10	R0
12A6-4	158	0.3	9	167	63	58.80	R1
017A-4	208	0.3	9	217	128	65.80	R2
025A-4	322	0.3	9	331	128	65.80	R2
033A-4	405	3.5	25	430	116	70	R3
039A-4	500	3.5	25	525	116	70	R3
046A-4	594	3.5	25	619	116	70	R3
062A-4	810	3.5	25	835	280	62	R4
073A-4	999	3.5	25	1024	280	62	R4
088A-4	1215	3.5	25	1240	280	62	R5
106A-4	1485	3.5	25	1510	435	67	R5
145A-4	1440	4.1	36	1476	435	67	R6
169A-4	1940	4.1	36	1976	450	67	R7
206A-4	2310	4.1	36	2346	550	67	R7
246A-4	3300	4.1	36	3336	550	65	R8
293A-4	3900	4.1	36	3936	1150	65	R8

Terminal and lead-through data for the power cables

Input, motor, resistor and DC cable lead-throughs, maximum wire sizes (per phase) and terminal screw sizes and tightening torques (T) are given below.

Desig. ACS560	Frame size	U1. V1. W1 / U2. V2. W2 / R+. R- / DC+. DC- terminal						PE terminals	
		min. (single core and / multicore)		Max.((single core and/ multi-core)		torque		max	torque
		mm ²	AWG	mm ²	AWG	N·m	lbf·ft	mm ²	N·m
3 phases $U_N = 400V$ (380...480V)									
02A6-4	R0	0.2/0.2	18	6/6	8	0.5...0.6	0.4	6	1.2
03A3-4	R0	0.2/0.2	18	6/6	8	0.5...0.6	0.4	6	1.2
04A0-4	R0	0.2/0.2	18	6/6	8	0.5...0.6	0.4	6	1.2

Desig. ACS560	Frame size	U1. V1. W1 / U2. V2. W2 / R+. R- / DC+. DC- terminal						PE terminals	
		min. (single core and / multicore)		Max.((single core and/ multi-core)		torque		max	torque
		mm ²	AWG	mm ²	AWG	N·m	lbf·ft	mm ²	N·m
05A6-4	R0	0.2/0.2	18	6/6	8	0.5...0.6	0.4	6	1.2
07A2-4	R0	0.2/0.2	18	6/6	8	0.5...0.6	0.4	6	1.2
09A4-4	R0	0.2/0.2	18	6/6	8	0.5...0.6	0.4	6	1.2
12A6-4	R1	0.2/0.2	18	6/6	8	0.5...0.6	0.4	6	1.2
017A-4	R2	0.5/0.5	20	6/16	4	1.2...1.5	1.0	6	1.2
025A-4	R2	0.5/0.5	20	6/16	4	1.2...1.5	1.0	6	1.2
033A-4	R3	0.5/0.5	20	35/25	2	2.5...4.5	3.3	10	1.5
039A-4	R3	0.5/0.5	20	35/25	2	2.5...4.5	3.3	10	1.5
046A-4	R3	0.5/0.5	20	35/25	2	2.5...4.5	3.3	16	1.5
062A-4	R4	0.5/0.5	20	50/50	1	4.0	3.0	16	1.5
073A-4	R4	0.5/0.5	20	50/50	1	5.6	4.1	16	1.5
088A-4	R5	6	10	70	2/0	5.6	4.1	25	2.2
106A-4	R5	6	10	70	2/0	5.6	4.1	35	2.2
145A-4	R6	25	3	150	300 MCM	30	22.1	50	9.8
169A-4	R7	95	3/0	240	500 MCM	30	22.1	70	9.8
206A-4	R7	95	3/0	240	500 MCM	30	22.1	70	9.8
246A-4	R8	2x50	2x1/0	2x150	2x300MCM	40	29.5	2x35	9.8
293A-4	R8	2x50	2x3/0	2x150	2x300MCM	40	29.5	2x50	9.8

Terminal and lead-through data for the control cables

Control cable lead-throughs, wire sizes and tightening torques (T) are given below.

Desig. ACS560	Frame size	Control Terminal			
		+24V. DCOM.DGND		DI. AI/O. AGND. RO. STO	
		mm ²	T (N·m)	mm ²	T (N·m)
3 phases $U_N = 400V$ (380...480V)					
02A6-4...09A4-4	R0	0.14...1.5	0.5...0.6	0.14...1.5	0.5...0.6
12A6-4	R1	0.14...1.5	0.5...0.6	0.14...1.5	0.5...0.6
017A-4. 025A-4	R2	0.14...1.5	0.5...0.6	0.14...1.5	0.5...0.6
033A-4...046A-4	R3	0.2...2.5	0.5...0.6	0.14...1.5	0.5...0.6
062A-4. 073A-4	R4	0.2...2.5	0.5...0.6	0.14...1.5	0.5...0.6
088A-4. 106A-4	R5	0.2...2.5	0.5...0.6	0.14...1.5	0.5...0.6
145A-4	R6	0.14...2.5	0.5...0.6	0.14...1.5	0.5...0.6
169A-4. 206A-4	R7	0.14...2.5	0.5...0.6	0.14...1.5	0.5...0.6
246A-4. 293A-4	R8	0.14...2.5	0.5...0.6	0.14...1.5	0.5...0.6

Electrical power network specification

Voltage (U_1)	Input voltage range 3~ 380...480 V AC. This is indicated in the type designation label as typical input voltage levels 3~ 400/480 V AC.
Network type	Public low voltage networks. TN (grounded), IT (ungrounded) and corner-grounded TN systems. See section Checking the compatibility with IT (ungrounded) and corner-grounded TN systems (page 69) .
Rated conditional short-circuit current (IEC 61439-1)	65 kA when protected by fuses given in the fuse tables
Frequency	47 to 63 Hz
Imbalance	Max. \pm 3% of nominal phase to phase input voltage
Fundamental power factor ($\cos \phi_1$)	0.98 (at nominal load)

Motor connection data

Motor types	Asynchronous AC induction motor
Frequency	0...500 Hz
Frequency resolution	0.01 Hz
Current	See section Ratings (page 119) .
Switching frequency	2 kHz, 4 kHz, 8 kHz, 12 kHz (depends on the frame and parameter settings)

Maximum recommended motor cable length **Operational functionality and motor cable length**

The drive is designed to operate with optimum performance with the following maximum motor cable lengths.

Frame size	Maximum motor cable length, 4 kHz			
	Scalar control		Vector control	
	m	ft	m	ft
Standard drive, without external options				
R0*	100	330	100	330
R1*	100	330	100	330
R2*	100	330	100	330
R3	300	990	300	990
R4	300	990	300	990
R5	300	990	300	990
R6	300	990	300	990
R7	300	990	300	990
R8	300	990	300	990

3AXD10000561047.xls A

Note 1: In multi-motor system, the sum of all motor cable lengths shall not exceed that given in the following table.

Note 2: Longer cables cause a motor voltage decrease which limits the available motor power. The decrease in voltage depends on the motor cable length and characteristics. A sine filter (optional) at the drive output can also cause a decrease in voltage. For more information, consult your local ABB Service representative (<http://new.abb.com/channel-partners/search>).

*)Conducted and radiated emissions of these motor cable lengths do not comply with EMC requirements.

■ **EMC compatibility and motor cable length**

To comply with the European EMC Directive (standard EN 61800-3), use the following maximum motor cable lengths at 4 kHz switching frequency. See the table below.

Frame size	Maximum motor cable length, 4 kHz	
	m	ft
EMC limits for Category C3 ¹⁾		
Standard drive with an internal EMC filter.		
See notes 3 and 4.		
R0	30	100
R1	30	100
R2	30	100
R3	100	330
R4	100	330

Frame size	Maximum motor cable length, 4 kHz	
	m	ft
R5	100	330
R6	150	492
R7	150	492
R8	150	492

¹⁾ See the terms in section *Definitions (page 141)*. Applicable for frames R4...R8. Frames R0...R2 require external EMC filter to meet the category 2 standards.

Note 2: Radiated emissions are according to C3 with an internal EMC filter.

Note 3: The internal EMC filter must be connected.

Note 4: Radiated and conducted emissions are according to category C3 with an internal filter and these cable lengths.

Note 5: Categories C1 and C2 meet requirements for connecting equipment to the public low-voltage networks.

Brake resistor connection data for frames R0...R3

Short-circuit protection (IEC/EN 61800-5-1, IEC 6439-1) The brake resistor output is conditionally short-circuit proof by IEC/EN 61800-5-1 and UL 508C. Rated conditional short-circuit current as defined in IEC 6439-1.

Control connection data

External power supply Maximum power:
 Frames size R0...R2: (Without external power supply)
 Frames size R3...R5: 25 W, 1.04 A at 24 V AC/DC $\pm 10\%$
 Frames size R6...R8 : 36W, 1.50A (24V AC/DC $\pm 10\%$, standard configuration)
 Supplied from an external power supply through option module CMOD-02 with frames R3...R5. With frames R6...R8 no options are needed.

+24 V DC output (Term. 10) Total load capacity of the outputs is 6.0W (250mA/24V) minus the power taken by the option modules installed on the board.

Digital inputs DI1...DI6 (Term. 13...18) Input type: NPN/PNP
DI1...DI4 and DI6 (Terminal 13...16 and 18)
 12/24V DC logic levels: "0" < 4V. "1" > 8V
 R_{in} : 2.68kOhm
 Hardware filtering: 0.04ms, digital filtering: 2ms sampling
DI5 (Terminal 17)
 Can be used as a digital or frequency input.
 12/24V DC logic levels: "0" < 3V. "1" > 8V
 R_{in} : 6.2kOhm
 Max. frequency 16kHz
 Symmetrical signal (duty cycle D = 0.50)

Relay outputs RO1...RO3 (Term. 19...27) 250 V AC / 30 V DC, 2 A

Analog inputs AI1 and AI2 (Term. 2 and 5)	<p>a dip switch or see section Switches (page 90). Current input: 0(4)...20 mA, R_{in}: 100 ohm Voltage input: 0(2)...10 V, R_{in}: > 200 kohm Inaccuracy: typical $\pm 1\%$, max. $\pm 1.5\%$ of full scale</p>
Analog outputs AO1 and AO2 (Term. 7 and 8)	<p>a dip switch or see section Switches (page 90). Current output: 0...20 mA, R_{load}: < 500 ohm Voltage output: 0...10 V, R_{load}: > 100 kohm (AO1 only) Inaccuracy: $\pm 1\%$ of full scale (in voltage and current modes)</p>
Reference voltage output for analog inputs +10V DC (Term. 4)	<p>Max. 20 mA output Inaccuracy: $\pm 1\%$</p>
Safe torque off (STO) inputs IN1 and IN2 (Term. 37 and 38)	<p>24 V DC logic levels: "0" < 5 V, "1" > 13 V R_{in}: 2.47 kohm</p>
STO cable	<p>Maximum cable length 300 m (984 ft) between activation switch (K) and drive control board, see sections Wiring (page 163) and Safety data (page 174).</p>
Control panel - drive connection	<p>EIA-485, male RJ-45 connector, max. cable length 100 m</p>
Control panel - PC connection	<p>USB Type Mini-B, max. cable length 2 m</p>

Grounding of frames R0...R2

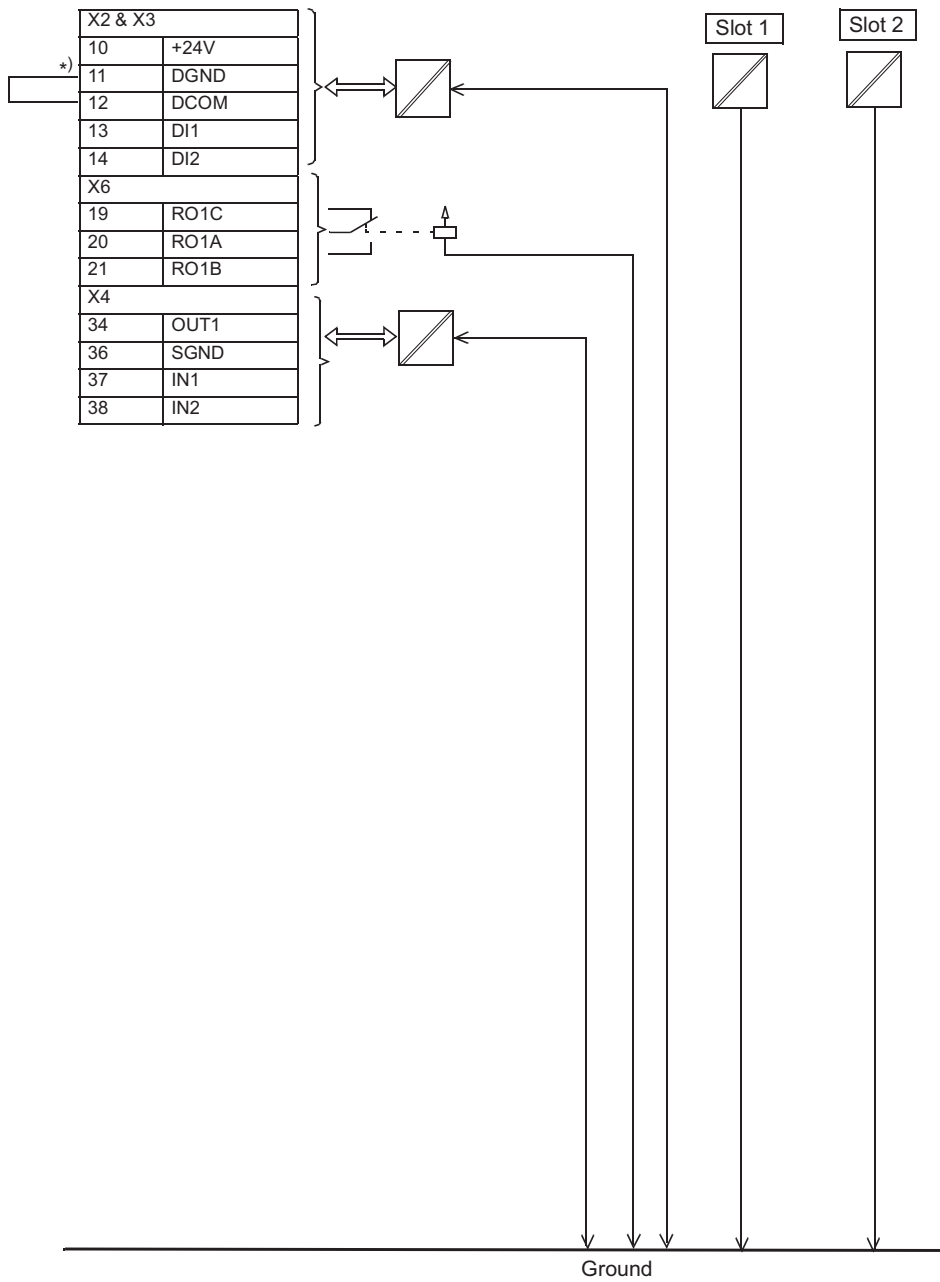

*) Installed with jumpers at the factory.

Grounding of frames R3...R5

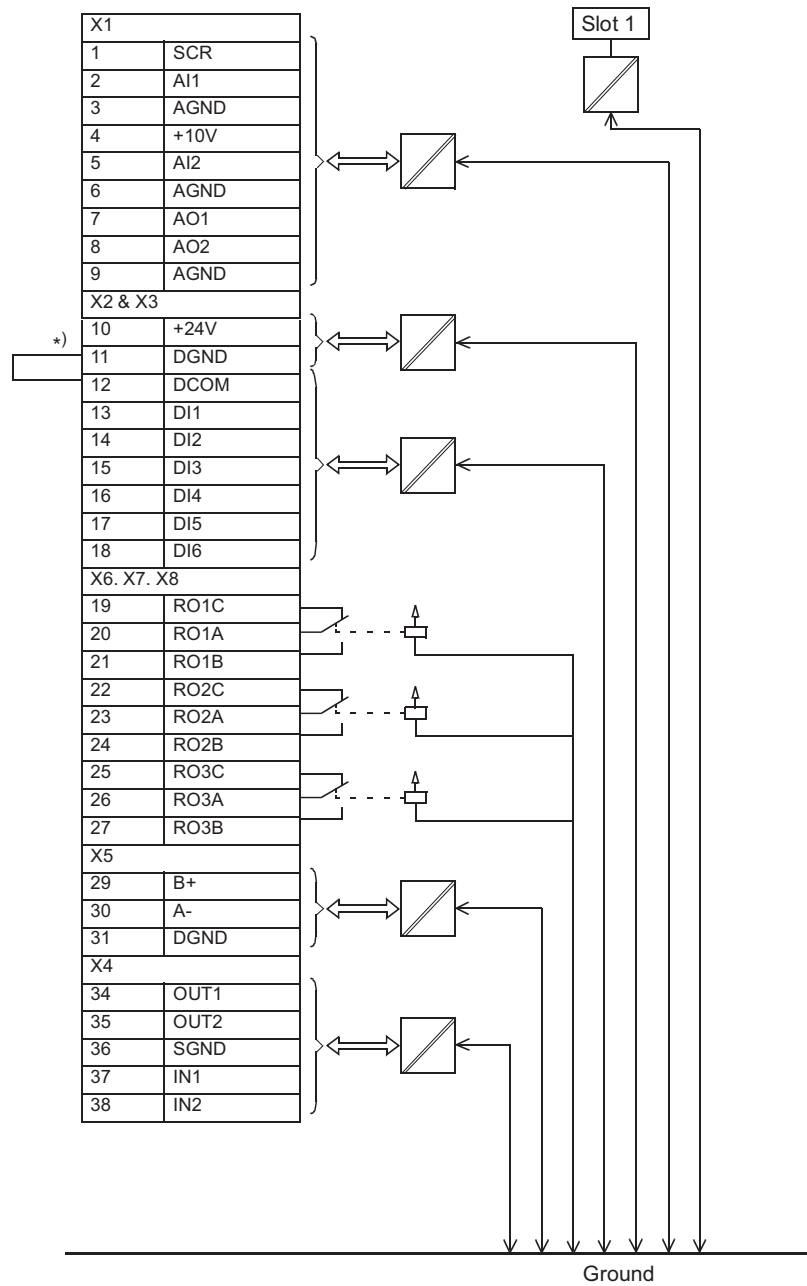

*) Installed with jumpers at the factory.

Grounding of frames R6...R8

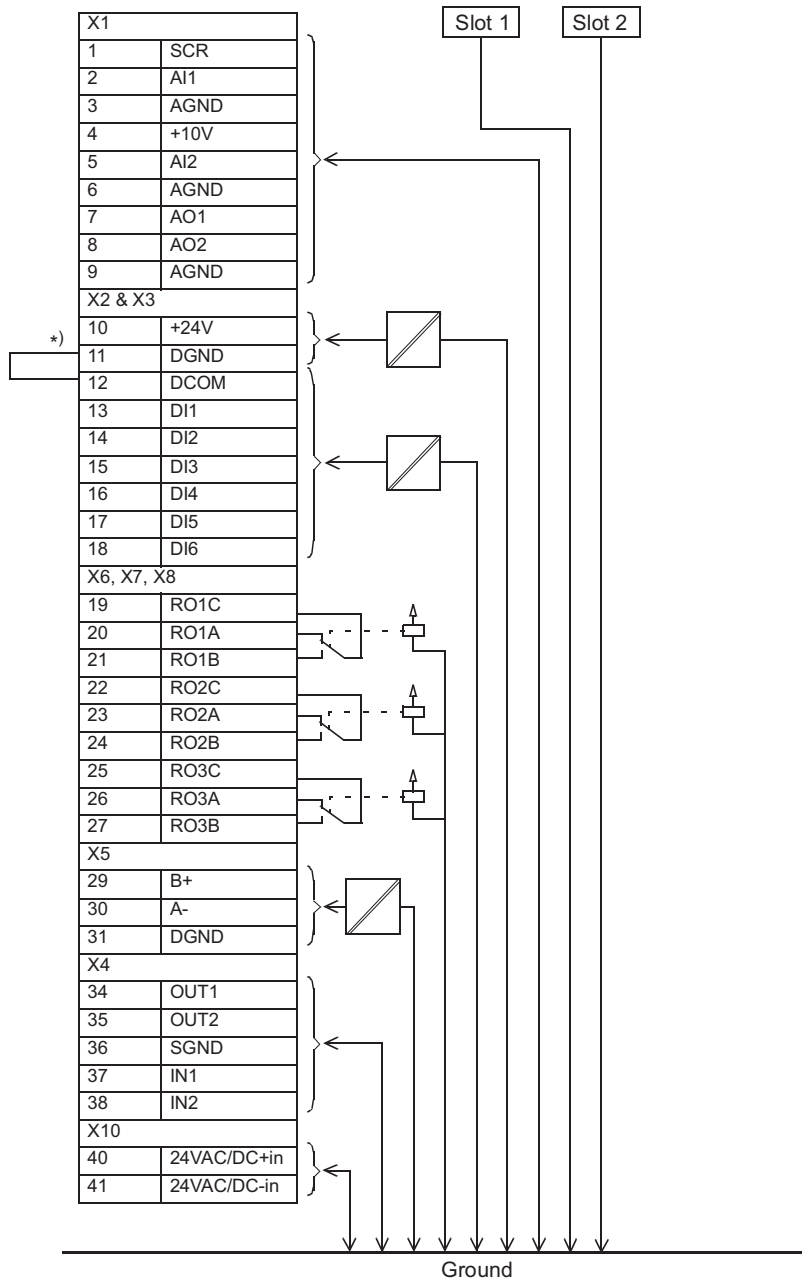

*) Jumper installed at factory

Auxiliary circuit power consumption

Maximum external power supply:

Frames R0...R5: 25 W, 1.04 A at 24 V AC/DC (For R0...R2 with optional module BAPO-01 and for R3...R5 with optional module CMOD-02)

Frames R6...R8: 36 W, 1.50 A at 24 V AC/DC (as standard, terminals 40...41)

Efficiency

Approximately 98% at nominal power level

Degree of protection

Ambient conditions

Environmental limits for the drive are given below. The drive is to be used in a heated, indoor, controlled environment. All printed circuit boards are conformal coated.

	Operation installed for stationary use	Storage in the protective package	Transportation in the protective package
Installation site altitude	<ul style="list-style-type: none"> 0 to 4000 m (13123 ft) above sea level¹⁾ 0 to 2000 m (6561 ft) above sea level²⁾ above 1000 m (3281 ft), see section <i>Altitude derating</i> (page 123).	-	-
Air temperature	-15 to +50 °C (5 to 122°C) for R0-R2 frames and -15 to 40 °C (5 to 104°F) for R3-R8 frames. Deration required to operate at 50 to 55 °C (122 to 131°F) for R0-R2 frames and at 40 to 55 °C (104°F to 131°F) for R3-R8 frames.	-40 to +70 °C (-40 to +158 °F)	-40 to +70 °C (-40 to +158 °F)
Relative humidity	5 to 95%	Max. 95%	Max. 95%
	No condensation allowed. Maximum allowed relative humidity is 60% in the presence of corrosive gases.		
Atmospheric pressure	70 to 106 kPa 0.7 to 1.05 atmospheres	70 to 106 kPa 0.7 to 1.05 atmospheres	60 to 106 kPa 0.6 to 1.05 atmospheres
Vibration (IEC 60068-2)	Max. 1 mm (0.04 in) (5 to 13.2 Hz), max. 7 m/s ² (23 ft/s ²) (13.2 to 100 Hz) sinusoidal	-	-
Vibration (ISTA)	-	<u>R0...R5</u> (ISTA 1A): Displacement, 25 mm peak to peak, 14200 vibratory impacts <u>R6...R8</u> (ISTA 3E): Random, overall Grms level of 0.52	

Shock/Drop (ISTA)	Not allowed	R0...R5 (ISTA 1A): Drop, 6 faces, 3 edges and 1 corner		
		Weight range	mm	in
		0...10 kg (0...22 lb)	760	29.9
		10...19 kg (22...42 lb)	610	24.0
		19...28 kg (42...62 lb)	460	18.1
		28...41 kg (62...90 lb)	340	13.4
		R6...R8 (ISTA 3E): Shock, incline impact: 1.1 m/s (3.61 ft/s) Shock, rotational edge drop: 200 mm (7.9 in)		

1) For neutral-grounded TN and TT systems and non-corner grounded IT systems.

2) For corner-grounded TN, TT and IT systems.

Materials

Drive enclosure

- PC/ABS 3 mm, color NCS 1502-Y (RAL 9002 / PMS 1C Cool Grey), RAL 9002 and PMS 425 C
- ot-dip zinc coated steel sheet 1.5 to 2.5 mm, thickness of coating 100 micrometers, color NCS 1502-Y

Package

Plywood, cardboard and molded pulp. Foam cushions PE, PP-E, bands PP.

Disposal

The main parts of the drive can be recycled to preserve natural resources and energy. Product parts and materials should be dismantled and separated.

Generally all metals, such as steel, aluminum, copper and its alloys, and precious metals can be recycled as material. Plastics, rubber, cardboard and other packaging material can be used in energy recovery. Printed circuit boards and large electrolytic capacitors need selective treatment according to IEC 62635 guidelines. To aid recycling, plastic parts are marked with an appropriate identification code.

Contact your local ABB distributor for further information on environmental aspects and recycling instructions for professional recyclers. End of life treatment must follow international and local regulations.

Applicable standards

The drive complies with the following standards. The compliance with the European Low Voltage Directive is verified according to standard EN 61800-5-1.

EN 60204-1:2006 + AC:2010 *Safety of machinery. Electrical equipment of machines. Part 1: General requirements. Provisions for compliance:* The final assembler of the machine is responsible for installing

- emergency-stop device
- supply disconnecting device.

IEC/EN 60529:1992 + A2: 2013 *Degrees of protection provided by enclosures (IP code)*

EN 61000-3-12:2011	<i>Electromagnetic compatibility (EMC) - Part 3-12: Limits - Limits for harmonic currents produced by equipment connected to public low-voltage systems with input current</i>
IEC/EN 61800-3:2004 + A1:2012	<i>Adjustable speed electrical power drive systems. Part 3: EMC requirements and specific test methods</i>
IEC/EN 61800-5-1:2007	<i>Adjustable speed electrical power drive systems. Part 5-1: Safety requirements – electrical, thermal and energy</i>
IEC 60664-1:2007	<i>Insulation coordination for equipment within low-voltage systems. Part 1: Principles, requirements and tests.</i>

CE marking

A CE mark is attached to the drive to verify that the drive follows the provisions of the European Low Voltage, EMC RoHirectives. The CE marking also verifies that the drive, in regard to its safety functions (such as Safe torque off), conforms with the Machinery Directive as a safety component.

■ Compliance with the European EMC Directive

The EMC Directive defines the requirements for immunity and emissions of electrical equipment used within the European Union. The EMC product standard (EN 61800- 3:2004 + A1:2012) covers requirements stated for drives. See section [Compliance with the EN 61800-3:2004 + A1:2012 \(page 141\)](#) below. The declaration (3AXD10000549782) is available on the Internet. See section *Document library on the Internet* on the inside of the back cover.

■ Compliance with the European ROHS II Directive 2011/65/EU

The RoHS II Directive defines the restriction of the use of certain hazardous substances in electrical and electronic equipment. The declaration (3AXD10000550609) is available on the Internet. See section *Document library on the Internet* on the inside of the back cover.

Compliance with the EN 61800-3:2004 + A1:2012

■ Definitions

EMC stands for **Electromagnetic Compatibility**. It is the ability of electrical/electronic equipment to operate without problems within an electromagnetic environment. Likewise, the equipment must not disturb or interfere with any other product or system within its locality.

First environment includes establishments connected to a low-voltage network which supplies buildings used for domestic purposes.

Second environment includes establishments connected to a network not directly supplying domestic premises.

Drive of category C1: drive of rated voltage less than 1000 V and intended for use in the first environment.

Drive of category C2: drive of rated voltage less than 1000 V and intended to be installed and started up only by a professional when used in the first environment.

Note:

A professional is a person or organization having necessary skills in installing and/or starting up power drive systems, including their EMC aspects.

Drive of category C3: drive of rated voltage less than 1000 V, intended for use in the second environment and not intended for use in the first environment.

■ Category C1

The emission limits are complied with the following provisions:

1. The optional EMC filter is selected according to the documentation and installed as specified in the EMC filter manual.
2. The motor and control cables are selected as specified in this manual.
3. The drive is installed according to the instructions given in this manual.
4. For the maximum motor cable length with 4 kHz switching frequency, see section ***Maximum recommended motor cable length*** (page 133).



WARNING!

In a domestic environment, this product may cause radio interference, in which case supplementary mitigation measures may be required.

■ Category C2

The emission limits are complied with the following provisions:

1. (For R0...R2) The optional EMC filter is selected according to the documentation and installed as specified in the EMC filter manual.
2. The motor and control cables are selected as specified in this manual.
3. The drive is installed according to the instructions given in this manual.
4. For the maximum motor cable length with 4 kHz switching frequency, see section ***Maximum recommended motor cable length*** (page 133).



WARNING!

The drive may cause radio interference if used in residential or domestic environment. The user is required to take measures to prevent interference, in association to the requirements for the CE compliance listed above, if necessary.

Note:

- Do not install a drive with the internal EMC filter connected on IT (ungrounded). The supply network becomes connected to ground potential through the internal EMC filter capacitors which may cause danger or damage to the drive. For disconnecting the EMC filter see section ***Frames R0...R3*** (page 70).
- Do not install a drive with internal EMC filter connected on corner-grounded TN systems; otherwise the drive will be damaged. For disconnecting the internal EMC filter see section ***Frames R0...R3*** (page 70).

■ Category C3

The drive complies with the standard with the following provisions:

1. The motor and control cables are selected as specified in this manual.
 2. The drive is installed according to the instructions given in this manual.
 3. For the maximum motor cable length with 4 kHz switching frequency, see section ***Maximum recommended motor cable length*** (page 133).
-



WARNING!

A drive of category C3 is not intended to be used on a low-voltage public network which supplies domestic premises. Radio frequency interference is expected if the drive is used on such a network.

■ **Category C4**

If the provisions under *Category C3* cannot be met, the requirements of the standard can be met as follows:

1. It is ensured that no excessive emission is propagated to neighboring low-voltage networks. In some cases, the inherent suppression in transformers and cables is sufficient. If in doubt, the supply transformer with static screening between the primary and secondary windings can be used.

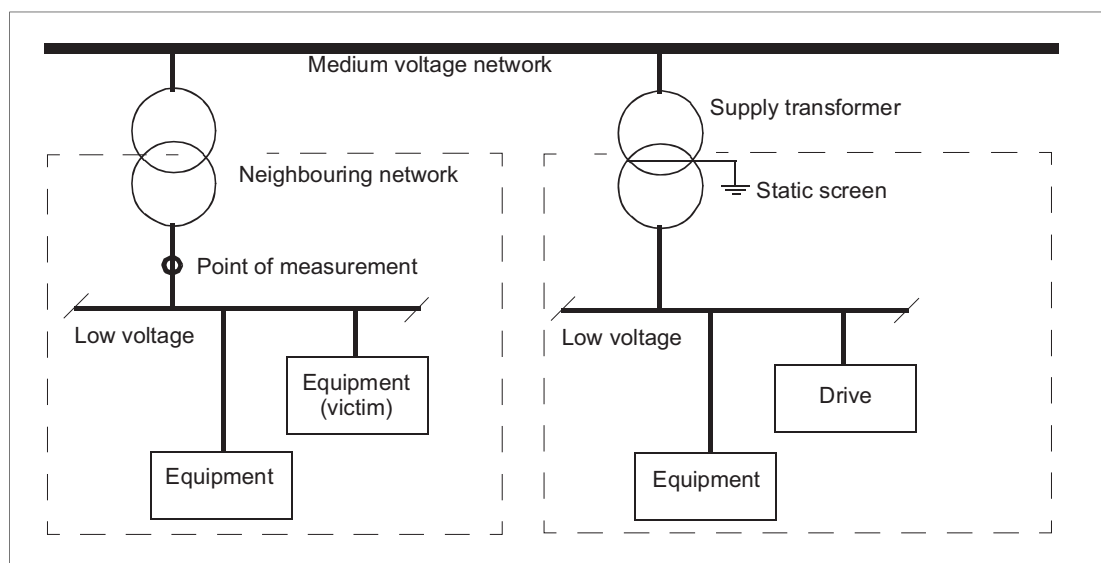

2. An EMC plan for preventing disturbances is drawn up for the installation. A template is available from the local representative.
3. The motor and control cables are selected as specified in this manual.
4. The drive is installed according to the instructions given in this manual.



WARNING!

A drive of category C4 is not intended to be used on a low-voltage public network which supplies domestic premises. Radio frequency interference is expected if the drive is used on such a network.



10

Dimension drawings

Contents of this chapter

This chapter shows the dimension drawings of the ACS560. The dimensions are given in millimeters and [inches].

Frame R0, IP20

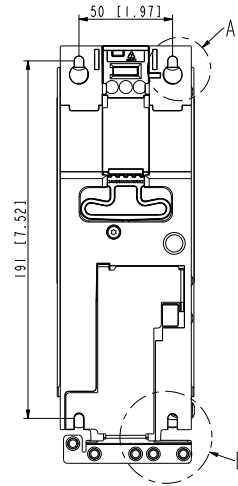
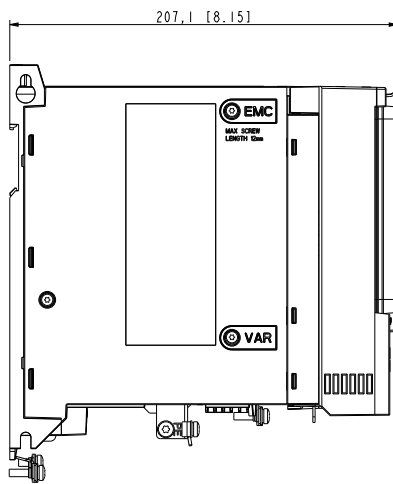
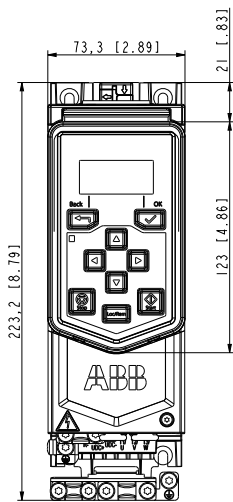
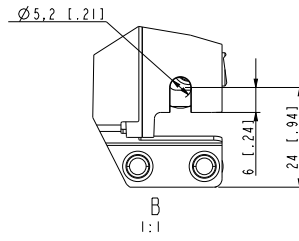
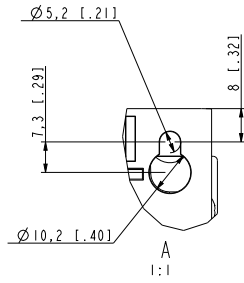
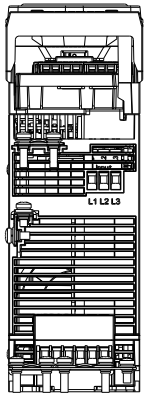

Frame R1, IP20

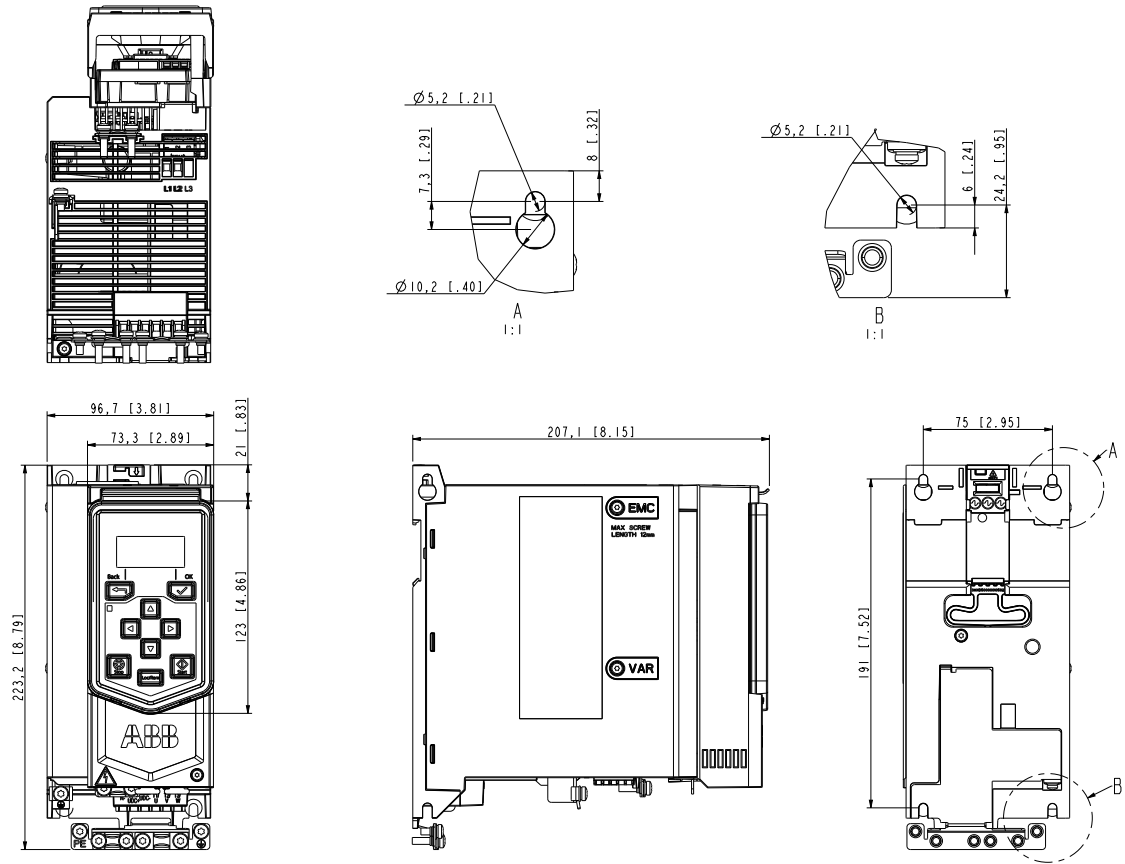

Frame R2, IP20

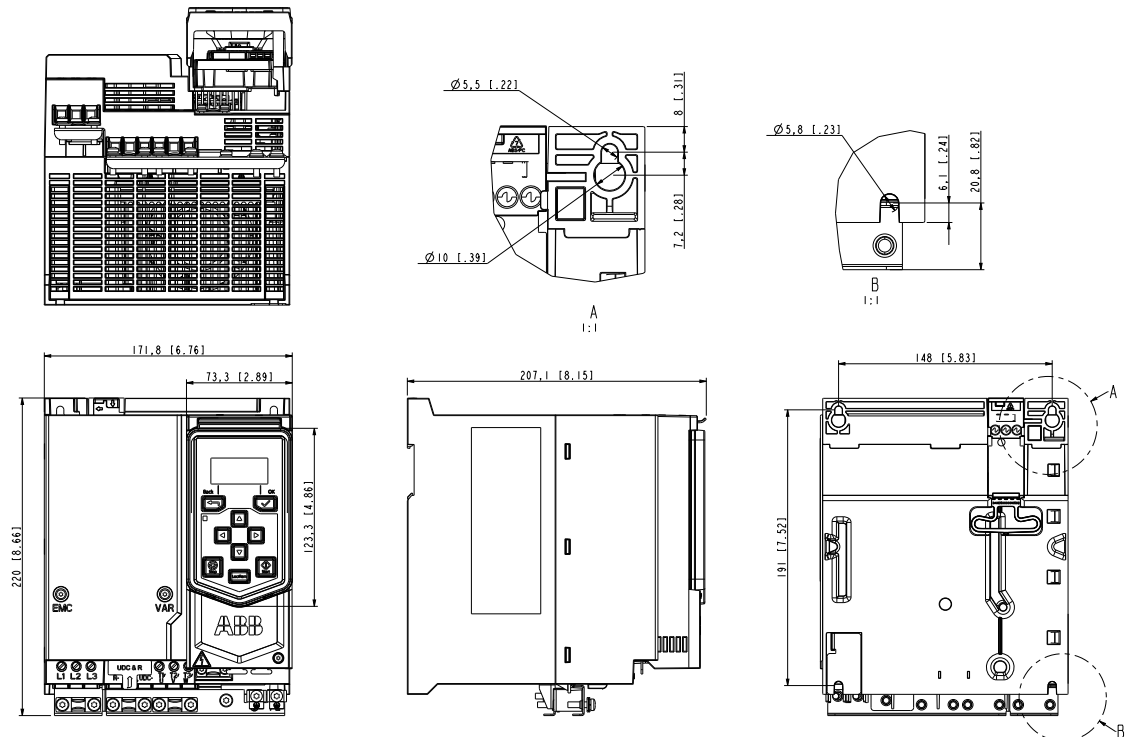

Frame R3, IP20

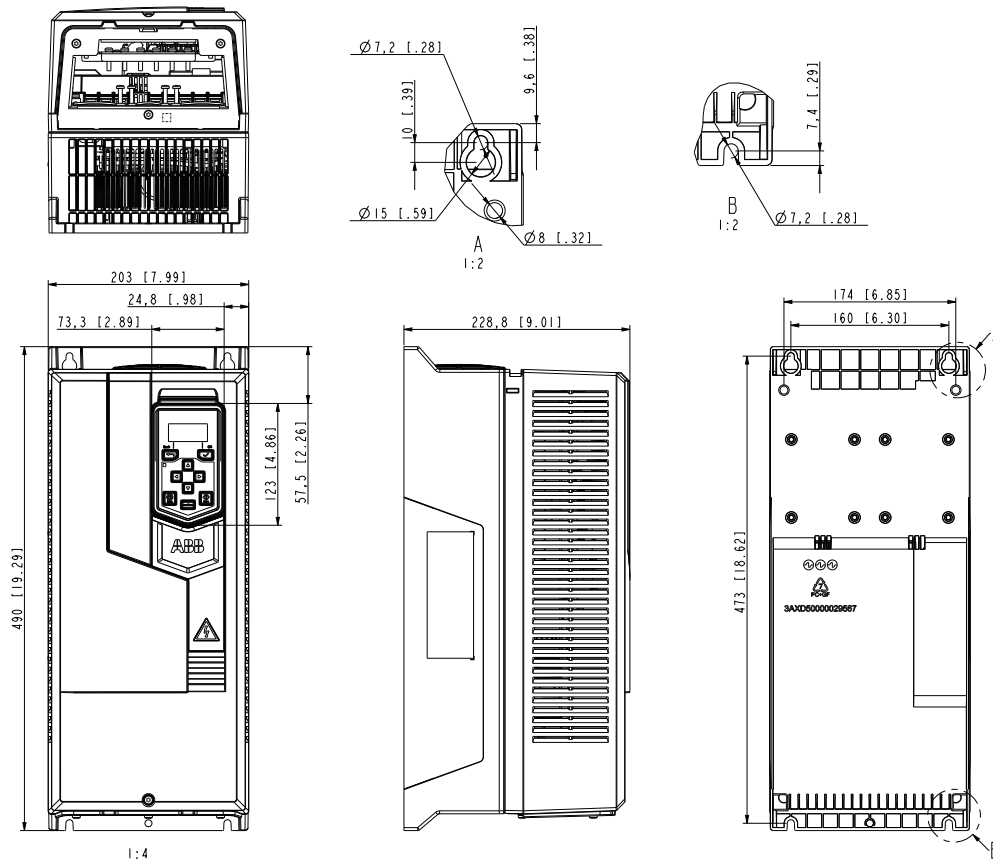

Frame R4, IP20

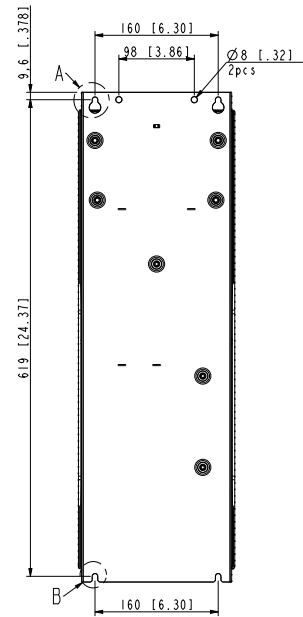
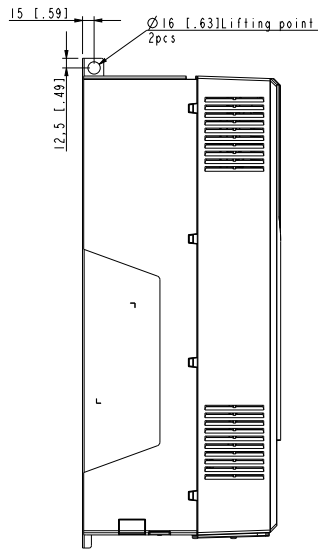
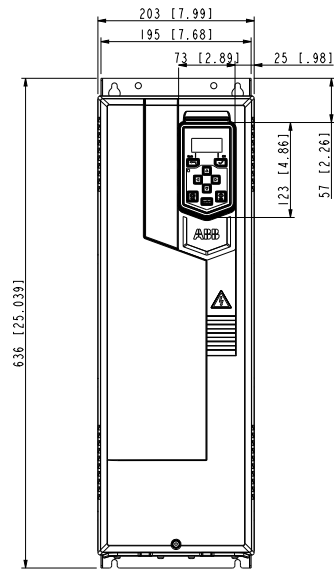
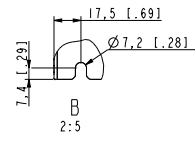
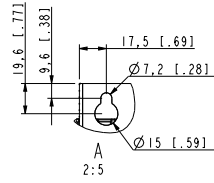
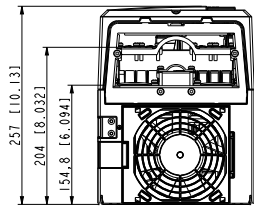

Frame R5, IP20

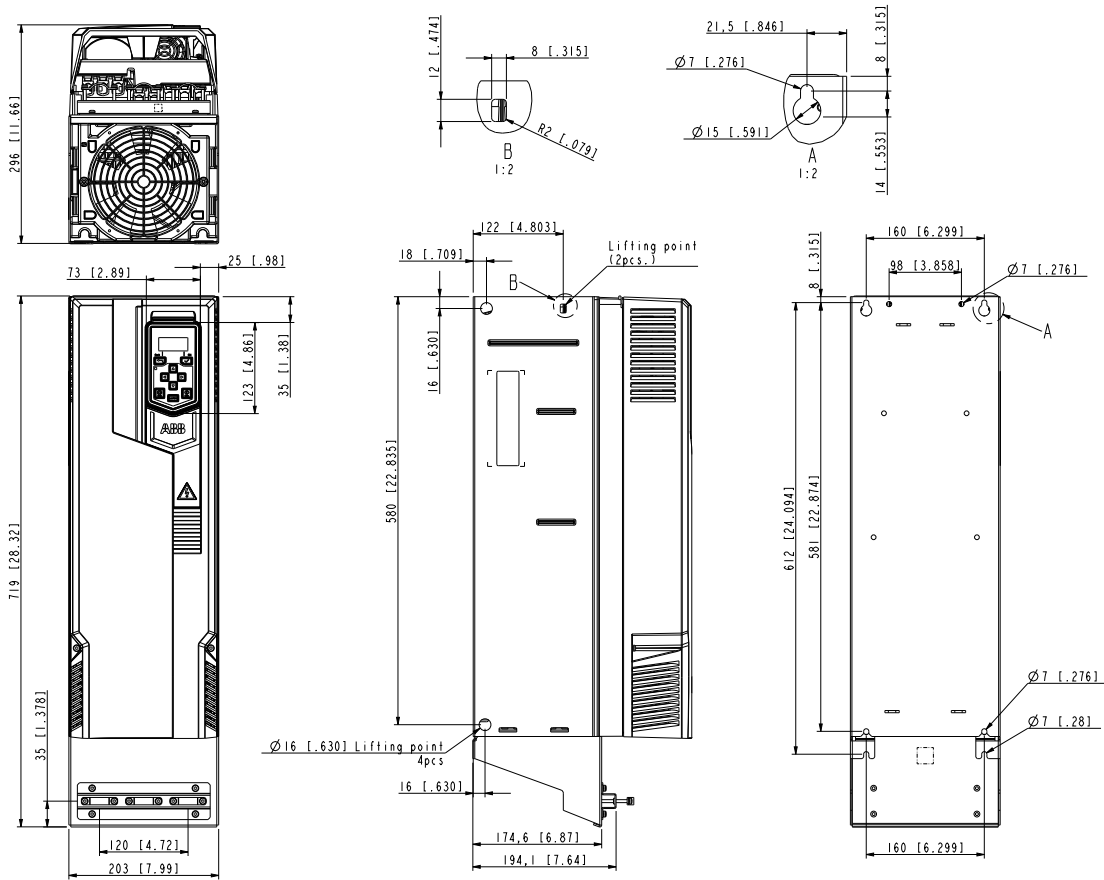

Frame R6, IP20

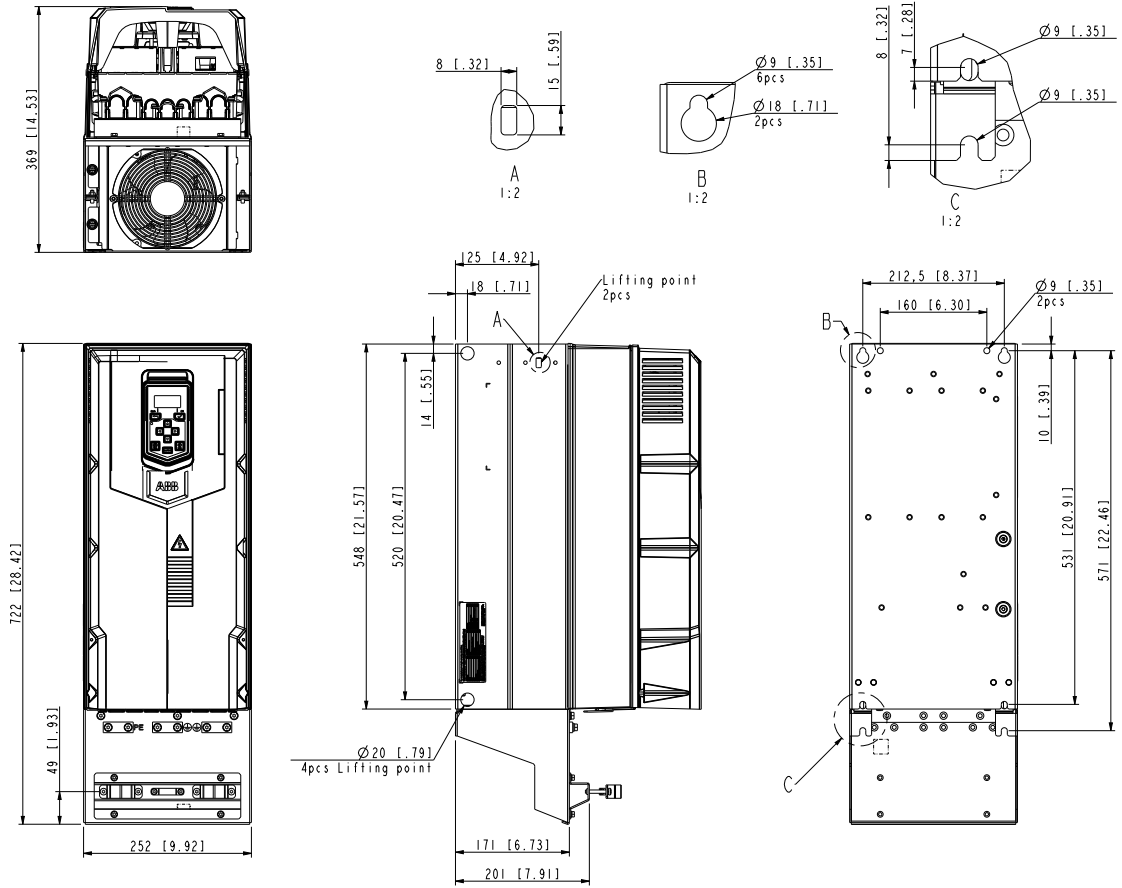

Frame R7, IP20

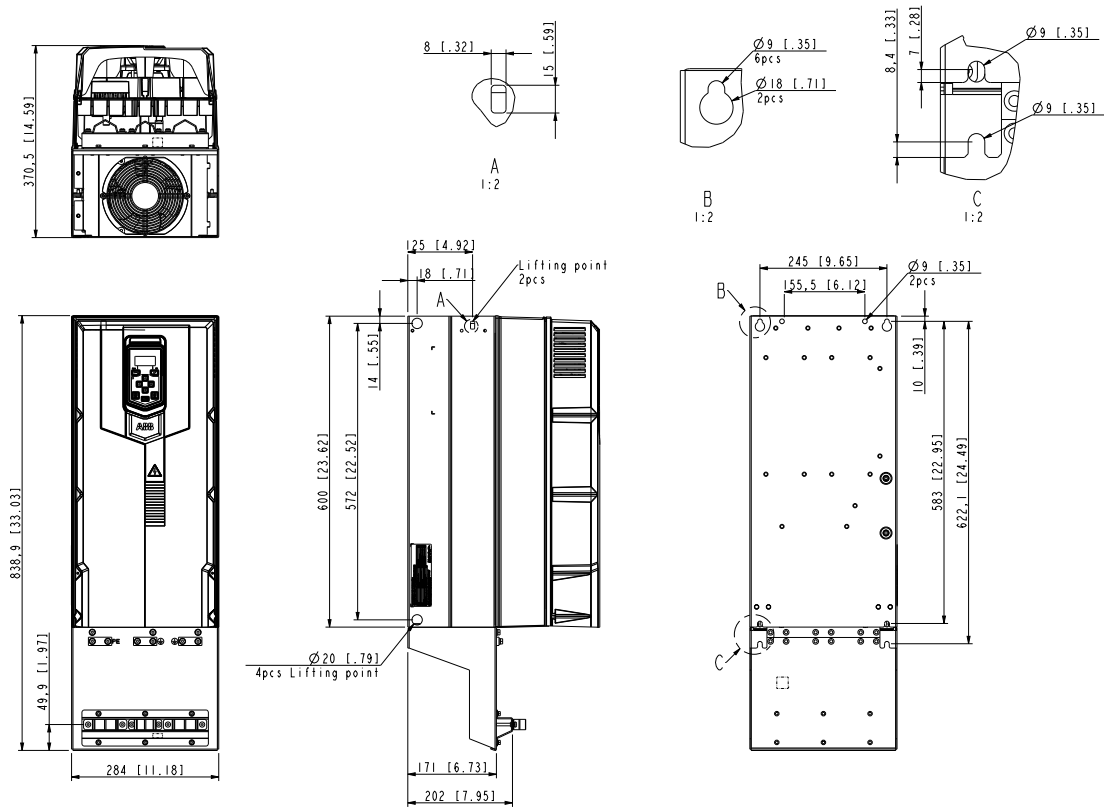

Frame R8, IP20

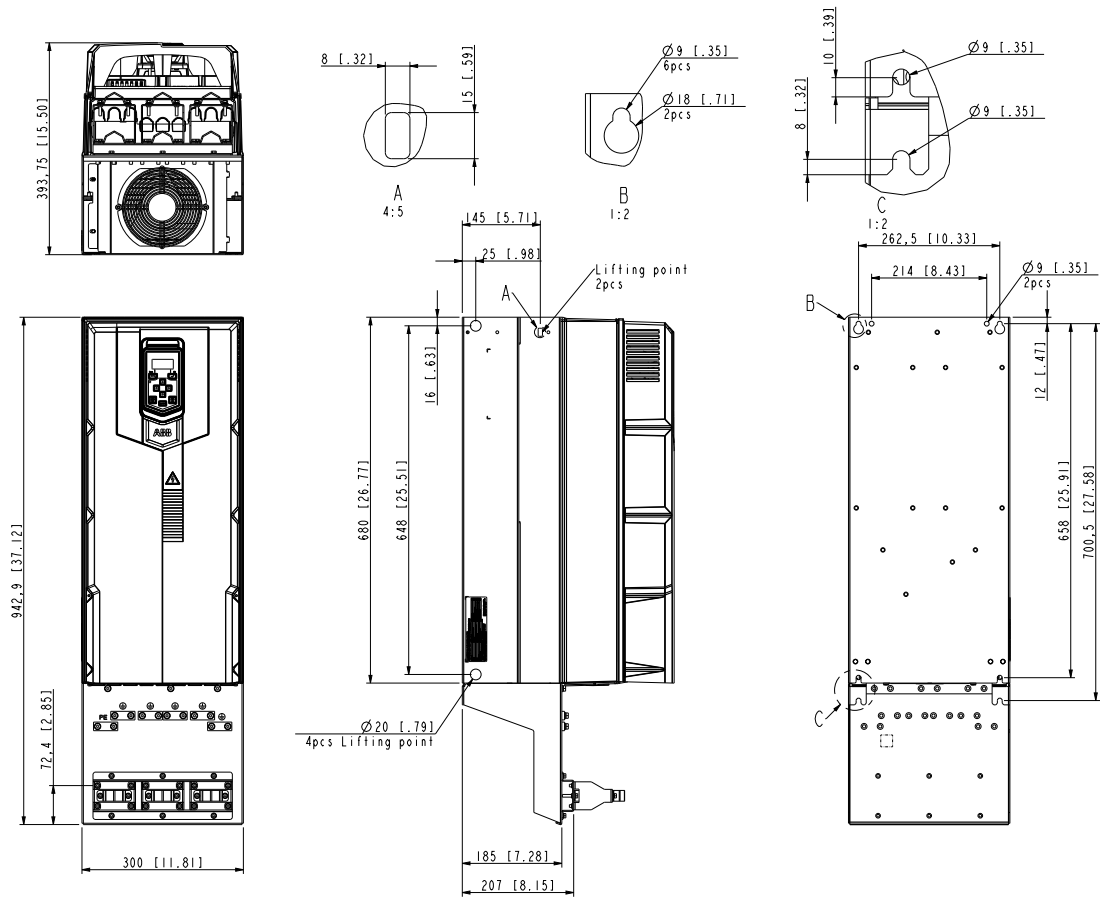

11

Resistor braking

Contents of this chapter

The chapter describes how to select the brake resistor and cables, protect the system, connect the brake resistor and enable resistor braking.

Operation principle and hardware description

The brake chopper handles the energy generated by a decelerating motor. The chopper connects the brake resistor to the intermediate DC circuit whenever the voltage in the circuit exceeds the limit defined by the control program. Energy consumption by the resistor losses lowers the voltage until the resistor can be disconnected.

For frames R0...R3 internal brake choppers and resistors, see below. For R4...R8 external brake choppers and resistors, see [Resistor braking, frames R4...R8 \(page 159\)](#).

Resistor braking, frames R0...R3

■ Planning the braking system

Selecting the brake resistor

Frames R0...R3 have an built-in brake chopper as standard equipment. The brake resistor is selected using the table and equations presented in this section.

1. Determine the required maximum braking power P_{Rmax} for the application. P_{Rmax} must be smaller than P_{BRmax} given in the table on page for the used drive type.
 2. Calculate resistance R with Equation 1.
 3. Calculate energy E_{Rpulse} with Equation 2.
 4. Select the resistor so that the following conditions are met:
 - The rated power of the resistor must be greater than or equal to P_{Rmax} .
-

156 Resistor braking

- Resistance R must be between R_{min} and R_{max} given in the table for the used drive type.
- The resistor must be able to dissipate energy E_{Rpulse} during the braking cycle T .

Equations for selecting the resistor:

Eq. 1. $U_n = 400V: R = \frac{450000}{P_{Rmax}}$

$U_n = 400V: R = \frac{450000}{P_{Rmax}}$

Eq. 2. $E_{Rpulse} = P_{Rmax} \cdot t_{on}$

Eq. 3. $P_{Rave} = P_{Rmax} \cdot \frac{t_{on}}{T}$

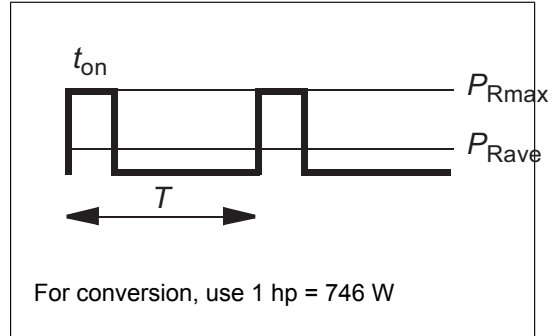

R =calculated brake resistor value (ohm). Make sure that:
 $R_{min} < R < R_{max}$

P_{Rmax} = maximum power during the braking cycle (W)

P_{Rave} = average power during the braking cycle (W)

P_{Rpulse} = energy conducted into the resistor during a single braking pulse (J)

t_{on} = length of the braking pulse (s)

T = length of the braking cycle (s).

The table shows reference resistor types for the maximum braking power.

Type ACS560	R_{min}	R_{max}	P_{BRcont}		P_{BRmax}		Reference resistor types	Braking time 1)
	ohm	ohm	kW	hp	kW	hp		
3-phase UN = 380 or 480V								Refer to braking resistor or manufacturer's documentation
01A8-4	99	933	0.37	0.50	0.56	0.74	CBH 360 C T 406 210R or CAR 200 D T 406 210R	
02A6-4	99	628	0.55	0.75	0.83	1.10		
03A3-4	99	428	0.75	1.00	1.13	1.50		
04A0-4	99	285	1.10	1.50	1.65	2.20		
05A6-4	99	206	1.50	2.00	2.25	3.00		
07A2-4	53	139	2.20	2.00	3.30	4.40	CBR-V 330 D T 406 78R UL	
09A4-4	53	102	3.00	3.00	4.50	6.00		
12A6-4	32	76	4.00	5.00	6.00	8.00		
017A-4	32	54	5.50	7.50	8.25	11.00	CBR-V 560 D HT 406 39R UL	
025A-4	23	39	7.50	10.00	11.25	15.00		

Type ACS560	R_{min}	R_{max}	P_{BRcont}		P_{BRmax}		Reference resistor types	Braking time 1)
	ohm	ohm	kW	hp	kW	hp		
033A-4	16	37	10	13.4	15	20.12	CBT-H-560 D HT 406 19R CBT-H-760 D HT 406 16R	
039A-4	10	27	13.3	17.83	20	26.82		
046A-4	10	22	16.67	22.25	25	33.53		
3AXD10000561047.xls A								

1) The maximum permitted braking cycle of the braking resistor differs from the that of the drive.

R_{min} = minimum allowed brake resistor that can be connected to the brake chopper

R_{max} = maximum allowed brake resistor that allows P_{max}

P_{max} = maximum braking capacity of the drive, must exceed the desired braking power.

P_{cont} = maximum brake resistance power when used continuously, more than the time mentioned.



WARNING!

Do not use a brake resistor with a resistance below the minimum value specified for the particular drive. The drive and the internal chopper are not able to handle the overcurrent caused by the low resistance.

Selecting and routing the brake resistor cables

Use a shielded cable with the conductor size specified in section [Terminal and lead-through data for the power cables \(page 130\)](#).

Minimizing electromagnetic interference

Follow these rules in order to minimize electromagnetic interference caused by the rapid current changes in the resistor cables:

- Install the cables away from other cable routes.
- Avoid long parallel runs with other cables. The minimum parallel cabling separation distance should be 0.3 meters.
- Cross the other cables at right angles.
- Keep the cable as short as possible in order to minimize the radiated emissions and stress on chopper IGBTs. The longer the cable the higher the radiated emissions, inductive load and voltage peaks over the IGBT semiconductors of the brake chopper.

Maximum cable length

The maximum length of the resistor cable(s) is 10 m (33 ft).

EMC compliance of the complete installation

Note:

ABB has not verified that the EMC requirements are fulfilled with external user-defined brake resistors and cabling. The EMC compliance of the complete installation must be considered by the customer.

Placing the brake resistor

Install the resistors outside the drive in a place where they will cool.

Arrange the cooling of the resistor in a way that:

- no danger of overheating is caused to the resistor or nearby materials
- the temperature of the room the resistor is located in does not exceed the allowed maximum.

Supply the resistor with cooling air/water according to the resistor manufacturer's instructions.



WARNING!

The materials near the brake resistor must be non-flammable. The surface temperature of the resistor is high. Air flowing from the resistor is of hundreds of degrees Celsius. If the exhaust vents are connected to a ventilation system, ensure that the material withstands high temperatures. Protect the resistor against physical contact.

Protecting the system in brake circuit fault situations

Protecting the system in cable and brake resistor short-circuitsituations

The input fuses will also protect the resistor cable when it is identical with the input cable.

Protecting the system against thermal overload

Equipping the drive with a main contactor is highly recommended for safety reasons. Wire the contactor so that it opens in case the resistor overheats. This is essential for safety since the drive will not otherwise be able to interrupt the main supply if the chopper remains conductive in a fault situation. An example wiring diagram is shown below. We recommend that you use resistors equipped with a thermal switch (1) inside the resistor assembly. The switch indicates overtemperature and overload.

We recommend that you also wire the thermal switch to a digital input of the drive.

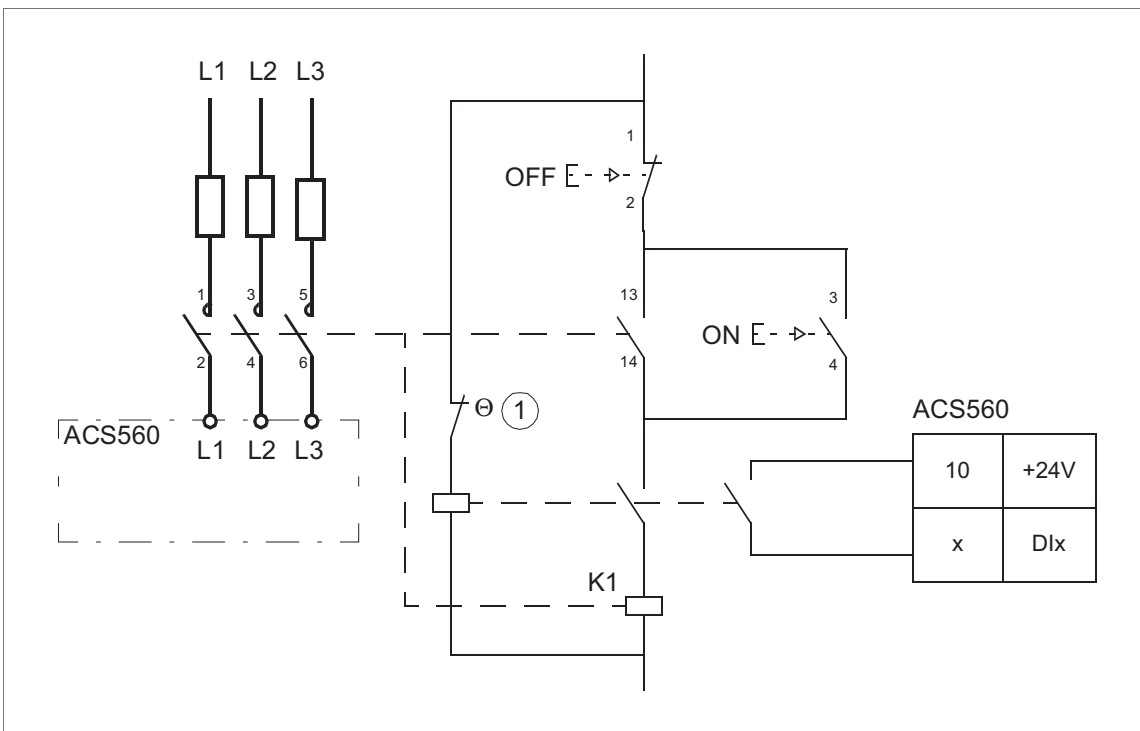

■ Mechanical installation

All brake resistors must be installed outside the drive. Follow the resistor manufacturer's instructions.

■ Electrical installation

Checking the insulation of the assembly

Follow the instructions given in section [Resistor braking, frames R0...R3 \(page 155\)](#).

Connection diagram

See section [Connection diagram \(page 73\)](#).

Connection procedure

See section [Connection procedure: frames R0...R2 \(page 75\)](#).

Connect the thermal switch of the brake resistor as described in section [Protecting the system against thermal overload \(page 158\)](#).

■ Start-up

Note:

Protective oil on the brake resistors will burn off when the brake resistor is used for the first time. Make sure that the airflow is sufficient.

Set the following parameters:

1. Disable the overvoltage control of the drive with parameter 30.30 Overvoltage control.
2. Set the source of parameter 31.01 External event 1 source to point to the digital input where the thermal switch of the brake resistor is wired.
3. Set parameter 31.02 External event 1 to Fault.
4. Enable the brake chopper by parameter 43.06 Brake chopper enable. If it is selected, set also the brake resistor overload protection parameters 43.08 and 43.09 according to the application.
5. Check the resistance value of parameter 43.10 Brake resistance.

With these parameter settings, the drive generates a fault and coasts to a stop on brake resistor overtemperature.



WARNING!

If the drive is equipped with a brake chopper but the chopper is not enabled by the parameter setting, the internal thermal protection of the drive against resistor overheating is not in use. In this case, the brake resistor must be disconnected.

Resistor braking, frames R4...R8

■ Planning the braking system

Frames R4...R8 need external brake choppers and resistors. The table below lists suitable choppers and resistors. Other resistors can also be used as long as the minimum resistance value and required power values are met.

For more information, see NBRA-6xx Braking Choppers Installation and start-up guide (3AFY58920541 [English]) and ACS-BRK Brake Units Installation and start-up guide (3AFY61514309 [English]).

160 Resistor braking

Type ACS560	R_{min}	R_{max}	P_{BRcont}		P_{BRmax}		Reference resistor types	Braking time ¹⁾
	ohm	ohm	kw	hp	kW	hp	Danotherm	s
3-phase UN = 380 or 480V								Refer to braking resistor or manufacturer's documentation
062A-4	7.8	18.1	20	27	30	40.2	Built in with the brake chopper	
073A-4	7.8	13.1	28	38	42	56.3	Built in with the brake chopper	
088A-4	7.8	10.7	34	46	51	68.4	Built in with the brake chopper	
106A-4	1.3	8.7	42	56	63	84.5	SAFUR125F500	
145A-4	1.3	7.1	51	68	77	103.2	SAFUR125F500	
169A-4	1.3	5.2	70	94	105	140.8	SAFUR200F500	
206A-4	1.3	4.3	84	113	126	168.9	SAFUR200F500	
246A-4	1.3	3.5	104	139	156	209.1	2xSAFUR125F500	
293A-4	1.3	2.9	125	168	187	250.7	2xSAFUR210F575	
3AXD10000561047.xls A								

1) The maximum permitted braking cycle of the braking resistor differs from the that of the drive.

R_{min} = minimum allowed brake resistor that can be connected to the brake chopper

R_{max} = maximum allowed brake resistor that allows P_{BRmax}

P_{BRmax} = maximum braking capacity of the drive, must exceed the desired braking power.

12

The Safe torque off function

Contents of this chapter

This chapter describes the Safe torque off (STO) function of the drive and gives instructions for its use.

Description

The Safe torque off function can be used, for example, to as the final actuator device of safety circuits that stop the drive in case of danger (such as an emergency stop circuit). Another typical application is a prevention of unexpected start-up function that enables short-time maintenance operations like cleaning or work on non-electrical parts of the machinery without switching off the power supply to the drive.

When activated, the Safe torque off function disables the control voltage of the power semiconductors of the drive output stage (A, see the diagrams below), thus preventing the drive from generating the torque required to rotate the motor. If the motor is running when Safe torque off is activated, it coasts to a stop.

The Safe torque off function has a redundant architecture, that is, both channels must be used in the safety function implementation. The safety data given in this manual is calculated for redundant use, and does not apply if both channels are not used.

The Safe torque off function complies with these standards:

Standard	Name
IEC 60204-1:2016 EN 60204-1:2006 + A1:2009 + AC:2010	<i>Safety of machinery – Electrical equipment of machines – Part 1: General requirements</i>
IEC 61000-6-7:2014	<i>Electromagnetic compatibility (EMC) – Part 6-7: Generic standards – Immunity requirements for equipment intended to perform functions in a safety-related system (functional safety) in industrial locations</i>

Standard	Name
IEC 61326-3-1:2017	<i>Electrical equipment for measurement, control and laboratory use – EMC requirements – Part 3-1: Immunity requirements for safety-related systems and for equipment intended to perform safety-related functions (functional safety) – General industrial applications</i>
IEC 61508-1:2010	<i>Functional safety of electrical/electronic/programmable electronic safety-related systems – Part 1: General requirements</i>
IEC 61508-2:2010	<i>Functional safety of electrical/electronic/programmable electronic safety-related systems – Part 2: Requirements for electrical/electronic/programmable electronic safety-related systems</i>
IEC 61511-1:2016	<i>Functional safety – Safety instrumented systems for the process industry sector</i>
IEC 61800-5-2:2016 EN 61800-5-2:2007	<i>Adjustable speed electrical power drive systems – Part 5-2: Safety requirements – Functional</i>
IEC 62061:2005 + A1:2012 + A2:2015 EN 62061:2005 + AC:2010 + A1:2013 + A2:2015	<i>Safety of machinery – Functional safety of safety-related electrical, electronic and programmable electronic control systems</i>
EN ISO 13849-1:2015	<i>Safety of machinery – Safety-related parts of control systems – Part 1: General principles for design</i>
EN ISO 13849-2:2012	<i>Safety of machinery – Safety-related parts of control systems – Part 2: Validation</i>

The function also corresponds to Prevention of unexpected start-up as specified by EN ISO 14118:2018 (ISO 14118:2017), and Uncontrolled stop (stop category 0) as specified in EN/IEC 60204-1.

■ **Compliance with the European Machinery Directive**

See the technical data.

Wiring

For the electrical specifications of the STO connection, see the technical data of the control board.

■ Connection principle (R0...R2)

Connection with internal power supply

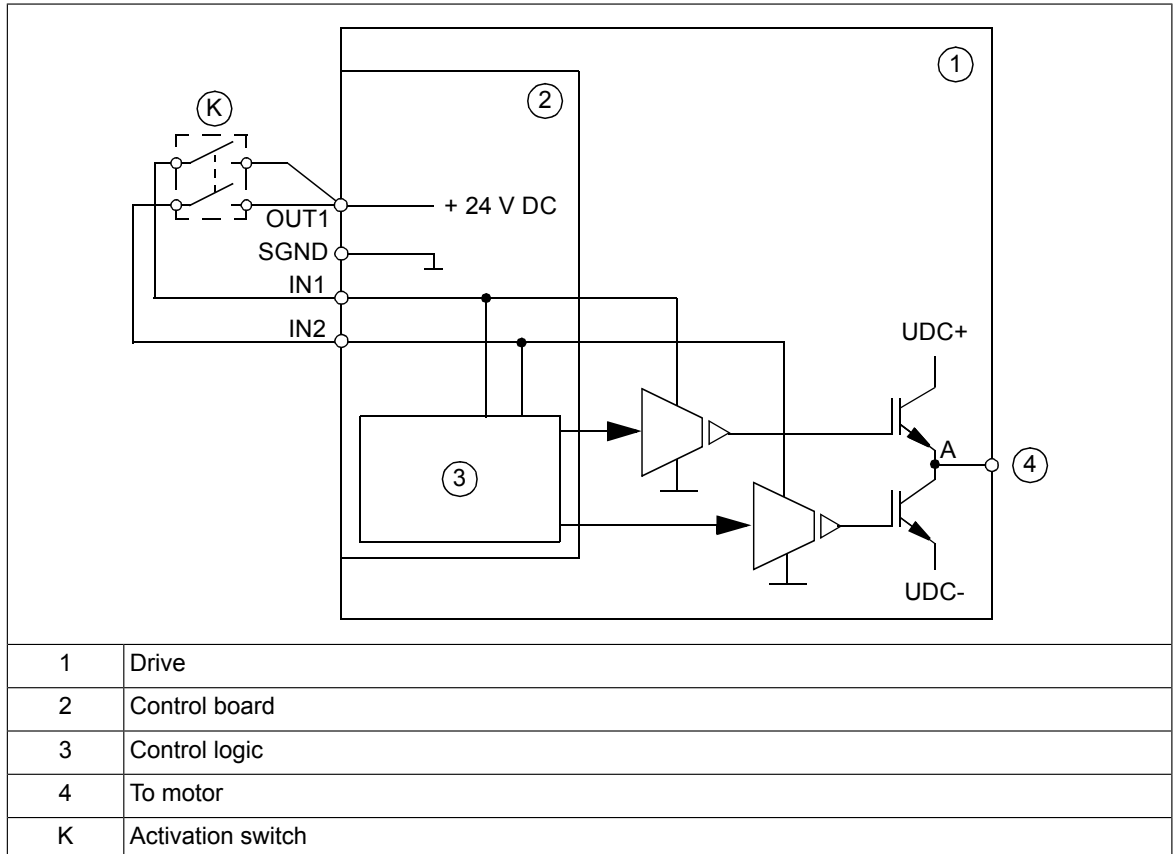

Connection with external power supply

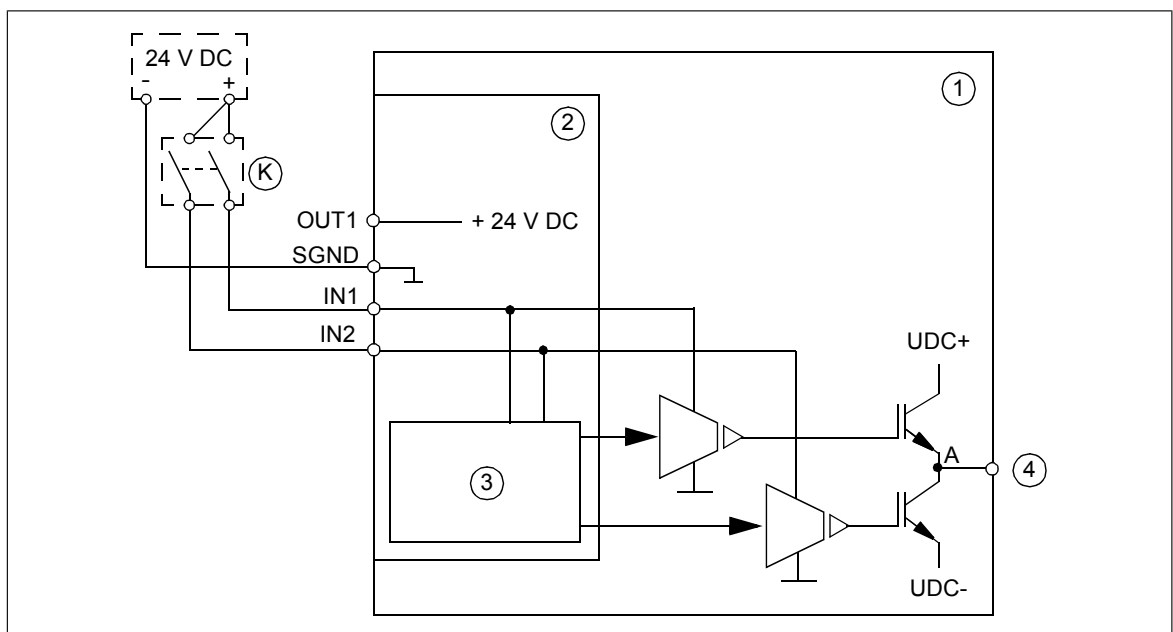

1	Drive
2	Control board
3	Control logic
4	To motor
K	Activation switch

■ **Wiring examples (R0...R2)**

Wiring with internal power supply

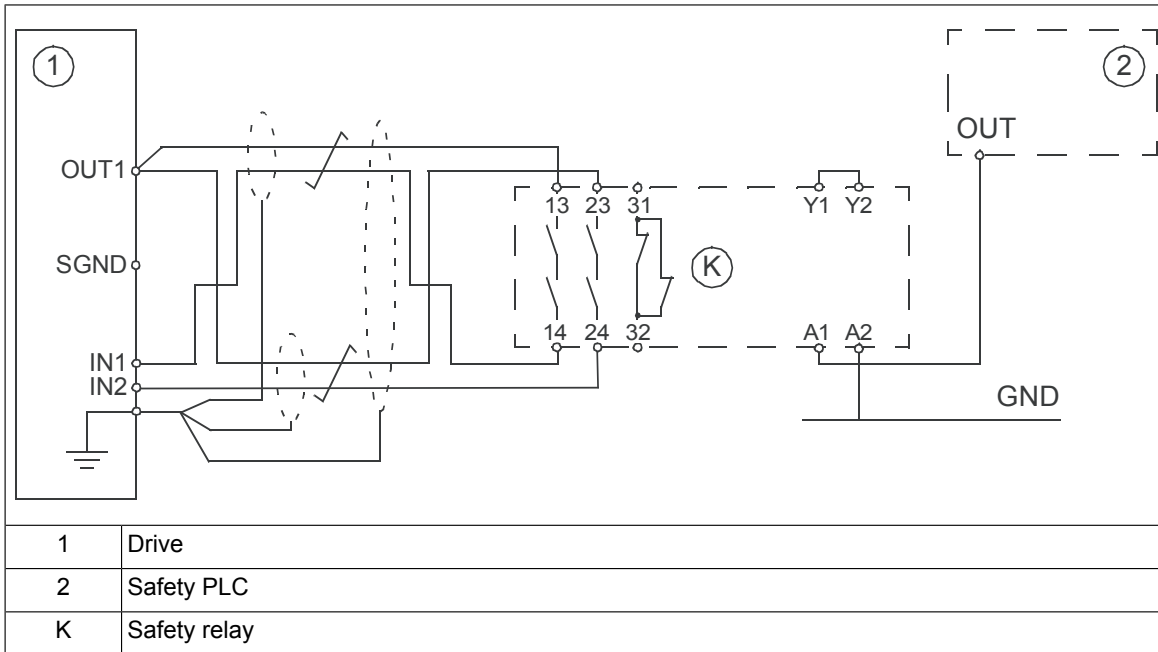

Wiring with external power supply

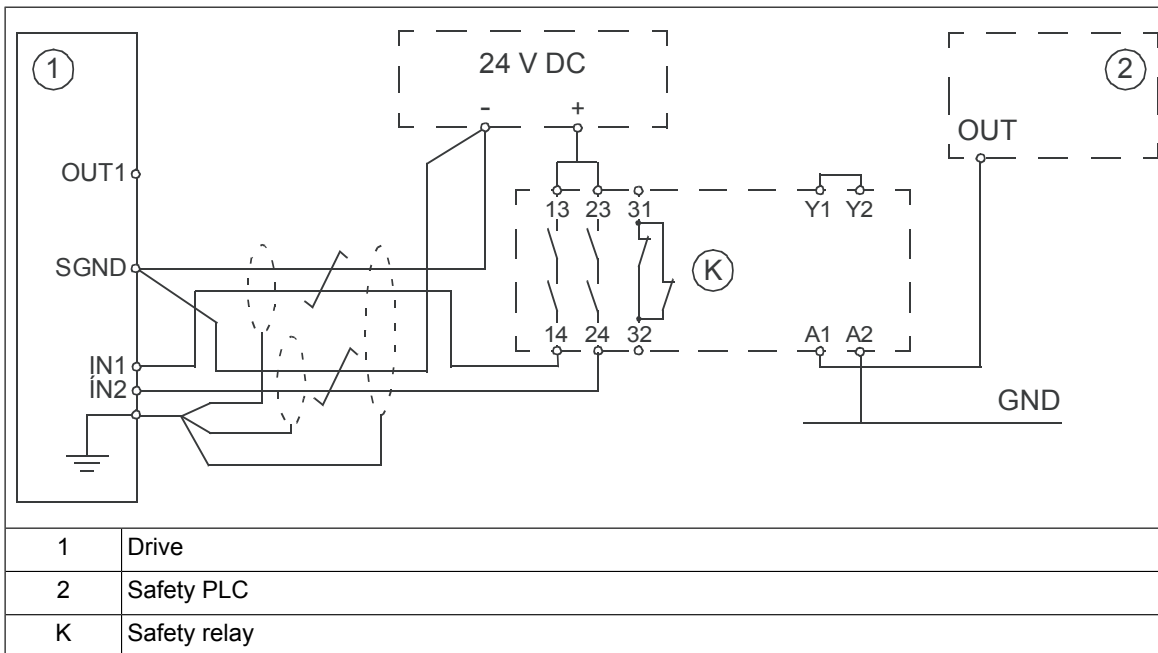

■ Connection principle (R3...R8)

Connection with internal power supply

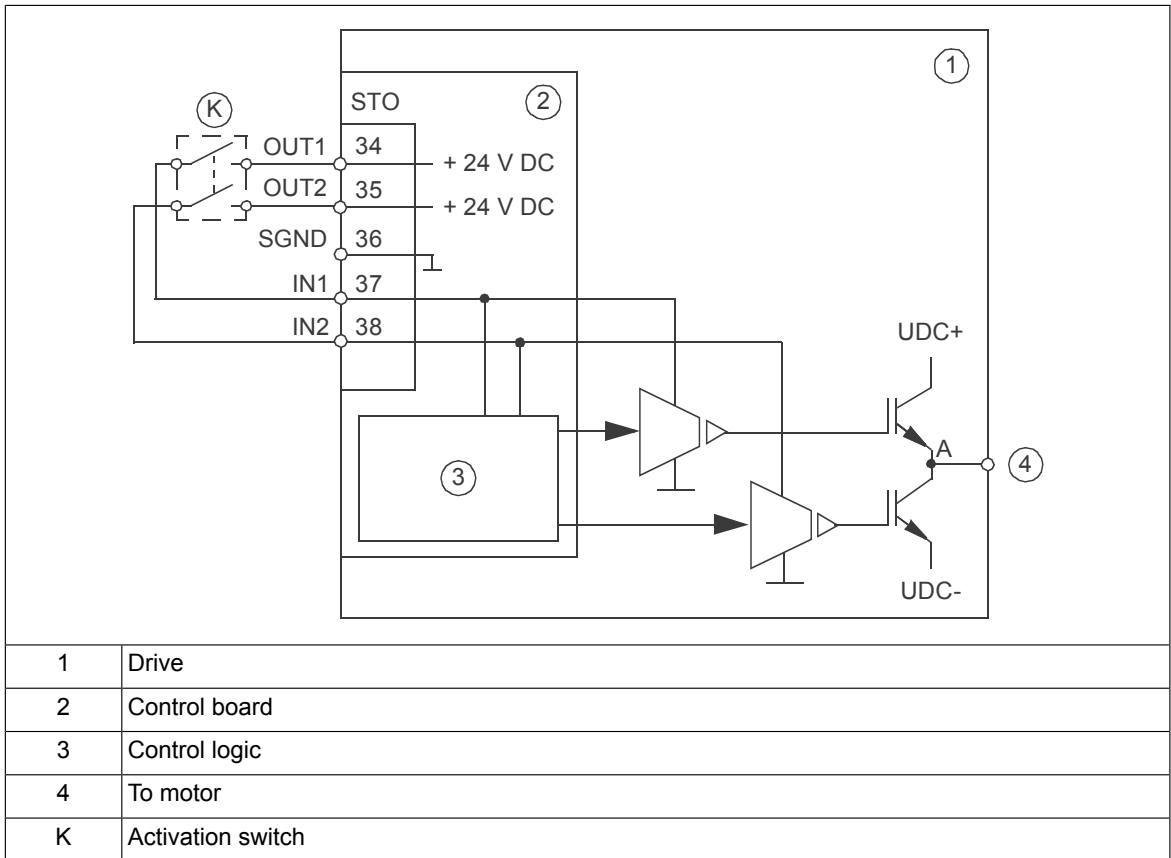

Connection with external power supply

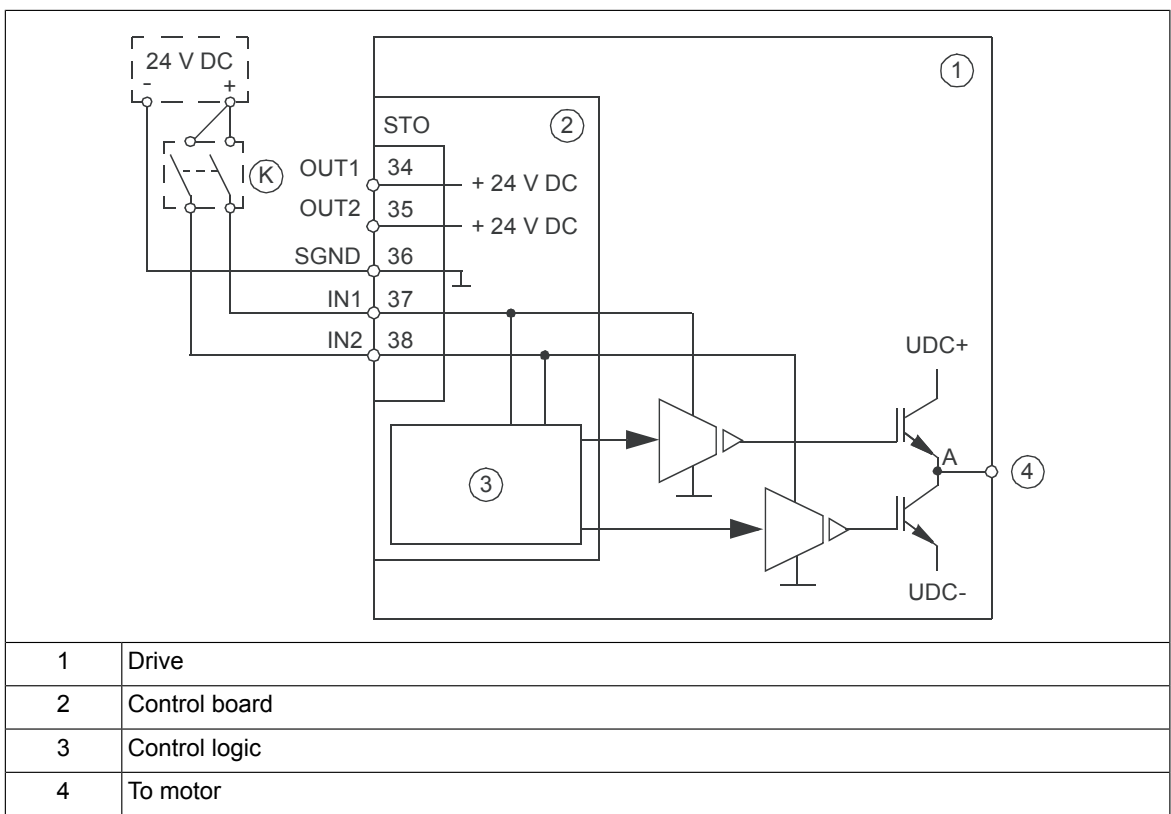

K	Activation switch
---	-------------------

■ **Wiring examples (R3...R8)**

Wiring with internal power supply

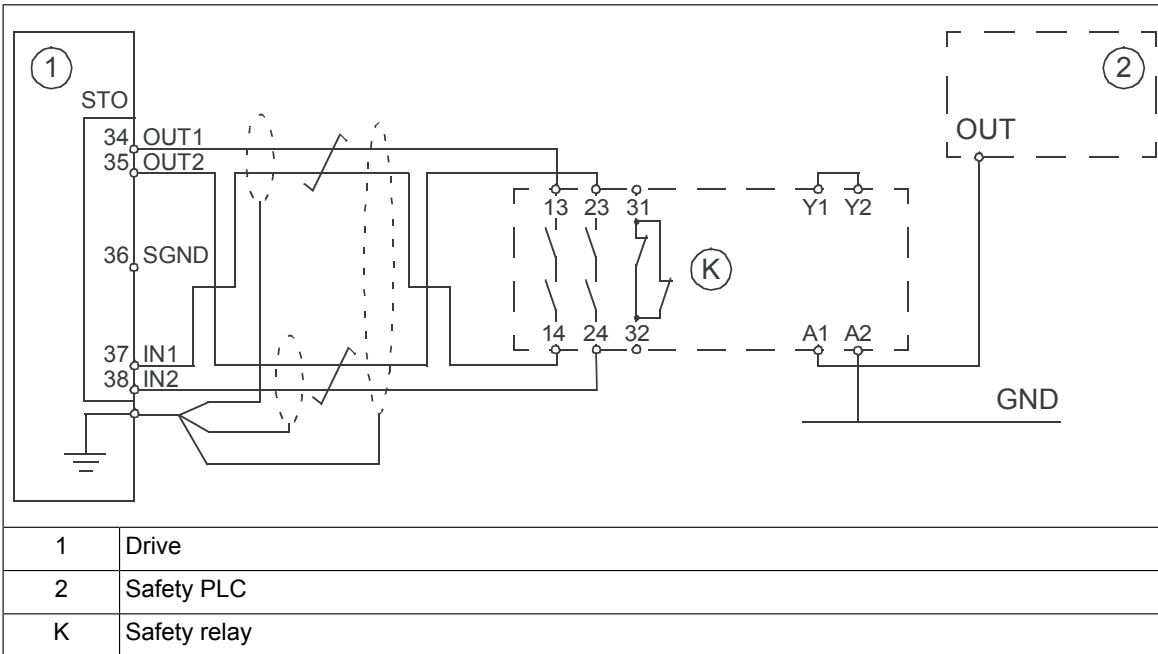

Wiring with external power supply

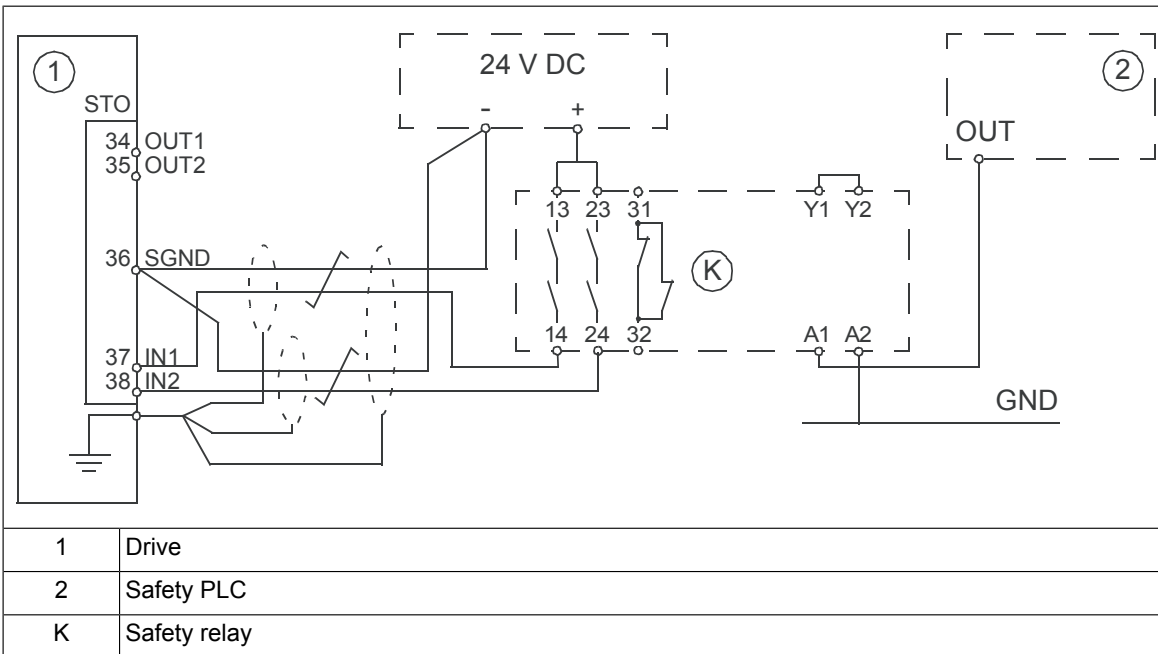

■ **Activation switch**

In the wiring diagrams, the activation switch has the designation [K]. This represents a component such as a manually operated switch, an emergency stop push button switch, or the contacts of a safety relay or safety PLC.

- In case a manually operated activation switch is used, the switch must be of a type that can be locked out to the open position.

- The contacts of the switch or relay must open/close within 200 ms of each other.

■ Cable types and lengths

- Double-shielded twisted-pair cable is recommended.
- Maximum cable lengths:
 - - Frames R0...R2: 100 m (330 ft) between activation switch [K] and drive control board
 - Frames R3...R8: 300 m (1000 ft) between activation switch [K] and drive control board
- 60 m (200 ft) between external power supply and control board

Note:

A short-circuit in the wiring between the switch and an STO terminal causes a dangerous fault. Therefore, it is recommended to use a safety relay (including wiring diagnostics) or a wiring method (shield grounding, channel separation) which reduces or eliminates the risk caused by the short-circuit.

Note:

The voltage at the STO input terminals of the drive must be at least 13 V DC to be interpreted as "1".

The pulse tolerance of the input channels is 1 ms.

■ Grounding of protective shields

- Ground the shield in the cabling between the activation switch and the control board at the control board only.
 - Ground the shield in the cabling between two control boards at one control board only.
-

Operation principle

1. The Safe torque off activates (the activation switch is opened, or safety relay contacts open).
2. The STO inputs of the drive control board de-energize.
3. The control board cuts off the control voltage from the output IGBTs.
4. The control program generates an indication as defined by parameter 31.22 (refer to the firmware manual of the drive).

The parameter selects which indications are given when one or both STO signals are switched off or lost. The indications also depend on whether the drive is running or stopped when this occurs.

Note:

This parameter does not affect the operation of the STO function itself. The STO function will operate regardless of the setting of this parameter: a running drive will stop upon removal of one or both STO signals, and will not start until both STO signals are restored and all faults reset.

Note:

The loss of only one STO signal always generates a fault as it is interpreted as a malfunction of STO hardware or wiring.

5. The motor coasts to a stop (if running). The drive cannot restart while the activation switch or safety relay contacts are open. After the contacts close, a reset may be needed (depending on the setting of parameter 31.22). A new start command is required to start the drive.
-

Start-up including acceptance test

To ensure the safe operation of a safety function, validation is required. The final assembler of the machine must validate the function by performing an acceptance test. The acceptance test must be performed

- at initial start-up of the safety function
- after any changes related to the safety function (circuit boards, wiring, components, settings, etc.)
- after any maintenance work related to the safety function.

■ Competence

The acceptance test of the safety function must be carried out by a competent person with adequate expertise and knowledge of the safety function as well as functional safety, as required by IEC 61508-1 clause 6. The test procedures and report must be documented and signed by this person.

■ Acceptance test reports

Signed acceptance test reports must be stored in the logbook of the machine. The report shall include documentation of start-up activities and test results, references to failure reports and resolution of failures. Any new acceptance tests performed due to changes or maintenance shall be logged into the logbook.

■ Acceptance test procedure

After wiring the Safe torque off function, validate its operation as follows.

Action	<input checked="" type="checkbox"/>
 WARNING! Follow the safety instructions. If you ignore them, injury or death, or damage to the equipment can occur.	<input type="checkbox"/>
Ensure that the drive can be run and stopped freely during start-up.	<input type="checkbox"/>
Stop the drive (if running), switch the input power off and isolate the drive from the power line using a disconnecter.	<input type="checkbox"/>
Check the STO circuit connections against the wiring diagram.	<input type="checkbox"/>
Close the disconnecter and switch the power on.	<input type="checkbox"/>
Test the operation of the STO function when the motor is stopped. <ul style="list-style-type: none"> • Give a stop command for the drive (if running) and wait until the motor shaft is at a standstill. Ensure that the drive operates as follows: <ul style="list-style-type: none"> • Open the STO circuit. The drive generates an indication if one is defined for the 'stopped' state in parameter 31.22 (see the firmware manual). • Give a start command to verify that the STO function blocks the drive's operation. The drive generates a warning. The motor should not start. • Close the STO circuit. • Reset any active faults. Restart the drive and check that the motor runs normally. 	<input type="checkbox"/>

170 The Safe torque off function

Action	<input checked="" type="checkbox"/>
<p>Test the operation of the STO function when the motor is running.</p> <ul style="list-style-type: none"> • Start the drive and ensure the motor is running. • Open the STO circuit. The motor should stop. The drive generates an indication if one is defined for the 'running' state in parameter 31.22 (see the firmware manual). • Reset any active faults and try to start the drive. • Ensure that the motor stays at a standstill and the drive operates as described above in testing the operation when the motor is stopped. • Close the STO circuit. • Reset any active faults. Restart the drive and check that the motor runs normally. 	<input type="checkbox"/>
<p>Test the operation of the failure detection of the drive. The motor can be stopped or running.</p> <ul style="list-style-type: none"> • Open the 1st channel of the STO circuit (wire coming to IN1). If the motor was running, it should coast to a stop. The drive generates a <i>FA81 Safe Torque Off 1 loss</i> fault indication (see the firmware manual). • Give a start command to verify that the STO function blocks the drive's operation. The motor should not start. • Close the STO circuit. • Reset any active faults. Restart the drive and check that the motor runs normally. • Open the 2nd channel of the STO circuit (wire coming to IN2). If the motor was running, it should coast to a stop. The drive generates a <i>FA82 Safe Torque Off 2 loss</i> fault indication (see the firmware manual). • Give a start command to verify that the STO function blocks the drive's operation. The motor should not start. • Close the STO circuit. • Reset any active faults. Restart the drive and check that the motor runs normally. 	<input type="checkbox"/>
<p>Document and sign the acceptance test report which verifies that the safety function is safe and accepted for operation.</p>	<input type="checkbox"/>

Use

1. Open the activation switch, or activate the safety functionality that is wired to the STO connection.
2. The STO inputs on the drive control board de-energize, and the control board cuts off the control voltage from the output IGBTs.
3. The control program generates an indication as defined by parameter 31.22 (refer to the firmware manual of the drive).
4. The motor coasts to a stop (if running). The drive will not restart while the activation switch or safety relay contacts are open.
5. Deactivate the STO by closing the activation switch, or resetting the safety functionality that is wired to the STO connection.
6. Reset any faults before restarting.



WARNING!

The Safe torque off function does not disconnect the voltage of the main and auxiliary circuits from the drive. Therefore maintenance work on electrical parts of the drive or the motor can only be carried out after isolating the drive from the supply and all other voltage sources.



WARNING!

(With permanent magnet or synchronous reluctance [SynRM] motors only)

In case of a multiple IGBT power semiconductor failure, the drive can produce an alignment torque which maximally rotates the motor shaft by $180/p$ degrees (with permanent magnet motors) or $180/2p$ degrees (with synchronous reluctance [SynRM] motors) regardless of the activation of the Safe torque off function. p denotes the number of pole pairs.

Notes:

- If a running drive is stopped by using the Safe torque off function, the drive will cut off the motor supply voltage and the motor will coast to a stop. If this causes danger or is not otherwise acceptable, stop the drive and machinery using the appropriate stop mode before activating the Safe torque off function.
 - The Safe torque off function overrides all other functions of the drive.
 - The Safe torque off function is ineffective against deliberate sabotage or misuse.
 - The Safe torque off function has been designed to reduce the recognized hazardous conditions. In spite of this, it is not always possible to eliminate all potential hazards. The assembler of the machine must inform the final user about the residual risks.
 - The Safe torque off diagnostics are not available during power outages, or when the drive is only powered by the BAPO-xx auxiliary power extension module.
 - The Safe torque off diagnostics are not available during power outages, or when the drive is only powered by a CMOD-xx multifunction extension module.
-

Maintenance

After the operation of the circuit is validated at start-up, the STO function shall be maintained by periodic proof testing. In high demand mode of operation, the maximum proof test interval is 20 years. In low demand mode of operation, the maximum proof test interval is 5 or 2 years; see section [Safety data \(page 174\)](#). It is assumed that all dangerous failures of the STO circuit are detected by the proof test. To perform the proof test, do the [Acceptance test procedure \(page 169\)](#).

Note:

See also the Recommendation of Use CNB/M/11.050 (published by the European co-ordination of Notified Bodies) concerning dual-channel safety-related systems with electromechanical outputs:

- When the safety integrity requirement for the safety function is SIL 3 or PL e (cat. 3 or 4), the proof test for the function must be performed at least every month.
- When the safety integrity requirement for the safety function is SIL 2 (HFT = 1) or PL d (cat. 3), the proof test for the function must be performed at least every 12 months.

The STO function of the drive does not contain any electromechanical components.

In addition to proof testing, it is a good practice to check the operation of the function when other maintenance procedures are carried out on the machinery.

Include the Safe torque off operation test described above in the routine maintenance program of the machinery that the drive runs.

If any wiring or component change is needed after start up, or the parameters are restored, follow the test given in section [Acceptance test procedure \(page 169\)](#).

Use only spare parts approved by ABB.

Record all maintenance and proof test activities in the machine logbook.

■ Competence

The maintenance and proof test activities of the safety function must be carried out by a competent person with adequate expertise and knowledge of the safety function as well as functional safety, as required by IEC 61508-1 clause 6.

Fault tracing

The indications given during the normal operation of the Safe torque off function are selected by drive control program parameter 31.22.

The diagnostics of the Safe torque off function cross-compare the status of the two STO channels. In case the channels are not in the same state, a fault reaction function is performed and the drive trips on an "STO hardware failure" fault. An attempt to use the STO in a non-redundant manner, for example activating only one channel, will trigger the same reaction.

See the firmware manual of the drive control program for the indications generated by the drive, and for details on directing fault and warning indications to an output on the control board for external diagnostics.

Any failures of the Safe torque off function must be reported to ABB.

Safety data

The safety data for the Safe torque off function is given below.

Note:

The safety data is calculated for redundant use, and does not apply if both STO channels are not used.

Frame size	SIL/SILCL	PL	SFF (%)	PFH (T ₁ = 20 a) (1/h)	PFD _{avg} (T ₁ = 2 a)	PFD _{avg} (T ₁ = 5 a)	MTTF _D (a)	DC (%)	Cat.	SC	HFT	CCF	T _M (a)
R0	3	e	>90	8.00E-09	6.68E-05	1.67E-04	2569	≥90	3	3	1	80	20
R1	3	e	>90	8.00E-09	6.68E-05	1.67E-04	2568	≥90	3	3	1	80	20
R2	3	e	>90	8.00E-09	6.68E-05	1.67E-04	2568	≥90	3	3	1	80	20
R3	3	e	>99	2.54E-09	2.23E-05	5.54E-05	2935	≥90	3	3	1	80	20
R4	3	e	>99	2.54E-09	2.23E-05	5.55E-05	2932	≥90	3	3	1	80	20
R5	3	e	>99	2.54E-09	2.23E-05	5.54E-05	2934	≥90	3	3	1	80	20
R6	3	e	>99	3.92E-09	3.44E-05	8.58E-05	9380	≥90	3	3	1	80	20
R7	3	e	>99	3.92E-09	3.44E-05	8.58E-05	9380	≥90	3	3	1	80	20
R8	3	e	>99	4.22E-09	3.69E-05	8.84E-05	8792	≥90	3	3	1	80	20

3AXD10000320081 D, 3AXD10000015777 J

- The following temperature profile is used in safety value calculations:
 - 670 on/off cycles per year with $\Delta T = 71.66 \text{ }^\circ\text{C}$
 - 1340 on/off cycles per year with $\Delta T = 61.66 \text{ }^\circ\text{C}$
 - 30 on/off cycles per year with $\Delta T = 10.0 \text{ }^\circ\text{C}$
 - 32 $^\circ\text{C}$ board temperature at 2.0% of time
 - 60 $^\circ\text{C}$ board temperature at 1.5% of time
 - 85 $^\circ\text{C}$ board temperature at 2.3% of time.
- The STO is a type A safety component as defined in IEC 61508-2.
- Relevant failure modes:
 - The STO trips spuriously (safe failure)
 - The STO does not activate when requested
 - A fault exclusion on the failure mode “short circuit on printed circuit board” has been made (EN 13849-2, table D.5). The analysis is based on an assumption that one failure occurs at one time. No accumulated failures have been analyzed.
- STO response times:
 - STO reaction time (shortest detectable break): 1 ms
 - STO response time:

- Frames R0...R2: 5 ms (typical), 10 ms (maximum)
- Frames R3...R8: 2 ms (typical), 5 ms (maximum)
- Fault detection time: Channels in different states for longer than 200 ms
- Fault reaction time: Fault detection time + 10 ms
- Indication delays:
 - STO fault indication (parameter 31.22) delay: < 500 ms
 - STO warning indication (parameter 31.22) delay: < 1000 ms

■ Abbreviations

Abbr.	Reference	Description
Cat.	EN ISO 13849-1	Classification of the safety-related parts of a control system in respect of their resistance to faults and their subsequent behavior in the fault condition, and which is achieved by the structural arrangement of the parts, fault detection and/or by their reliability. The categories are: B, 1, 2, 3 and 4.
CCF	EN ISO 13849-1	Common cause failure (%)
DC	EN ISO 13849-1	Diagnostic coverage
HFT	IEC 61508	Hardware fault tolerance
MTTF _D	EN ISO 13849-1	Mean time to dangerous failure: (Total number of life units) / (Number of dangerous, undetected failures) during a particular measurement interval under stated conditions
PFD _{avg}	IEC 61508	Average probability of dangerous failure on demand, that is, mean unavailability of a safety-related system to perform the specified safety function when a demand occurs
PFH	IEC 61508	Average frequency of dangerous failures per hour, that is, average frequency of a dangerous failure of a safety related system to perform the specified safety function over a given period of time
PL	EN ISO 13849-1	Performance level. Levels a...e correspond to SIL
SC	IEC 61508	Systematic capability
SFF	IEC 61508	Safe failure fraction (%)
SIL	IEC 61508	Safety integrity level (1...3)
SILCL	IEC/EN 62061	Maximum SIL (level 1...3) that can be claimed for a safety function or subsystem
STO	IEC/EN 61800-5-2	Safe torque off
T ₁	IEC 61508-6	Proof test interval. T ₁ is a parameter used to define the probabilistic failure rate (PFH or PFD) for the safety function or subsystem. Performing a proof test at a maximum interval of T ₁ is required to keep the SIL capability valid. The same interval must be followed to keep the PL capability (EN ISO 13849) valid. See also section Maintenance.
T _M	EN ISO 13849-1	Mission time: the period of time covering the intended use of the safety function/device. After the mission time elapses, the safety device must be replaced. Note that any T _M values given cannot be regarded as a guarantee or warranty.



13

Optional I/O and power extension modules

Contents of this chapter

This chapter describes how to install and start up the optional BIO-01 I/O extension module, CMOD-02 power extension module and BAPO-01 power extension module.

■ BIO-01 I/O extension module

Contents of this chapter

This chapter contains a description and technical data of the optional BIO-01 I/O extension module. The chapter also contains references to the relevant other content elsewhere in the manual.

Note:

BIO-01 I/O extension module is applicable only for R0...R2 frames.

Safety instructions



WARNING!

Obey the instructions in [Safety instructions \(page 13\)](#). If you ignore them, injury or death, or damage to the equipment can occur.

BIO-01 product overview

The BIO-01 front option module (Option +L515) is an I/O extension module for R0...R2 frames and can also be used with any of the fieldbus optional module. The BIO-01 I/O extension module provides:

- three additional digital inputs (DI3, DI4 and DI5)
 - one analog input (AI1), and
-

- one digital output (DO1).

The digital output (DO1) is referred as DIO1 in the firmware. This works only in output mode. You can also use DI4 and DI5 as frequency inputs and DO1 as a frequency output.

BIO-01 terminal block is removable and uses spring clamps for assembly.

Layout

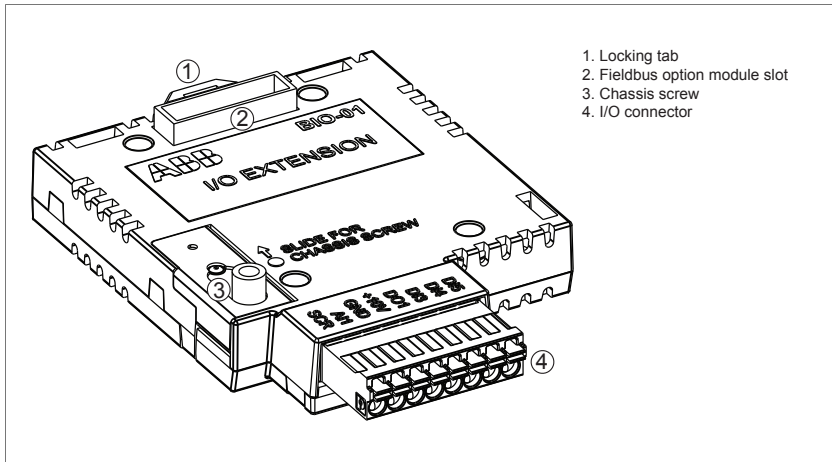

Mechanical installation

See section [Option modules \(page 99\)](#) .

Before you install the BIO-01 option module, make sure that the chassis screw slider is in the top position. After the option module is installed, tighten the chassis screw and move the slider to the bottom position.

The BIO-01 option module kit comes with a higher cable clamp plate (1). Use this cable clamp plate to ground the wires that connect to the BIO-01 option module.

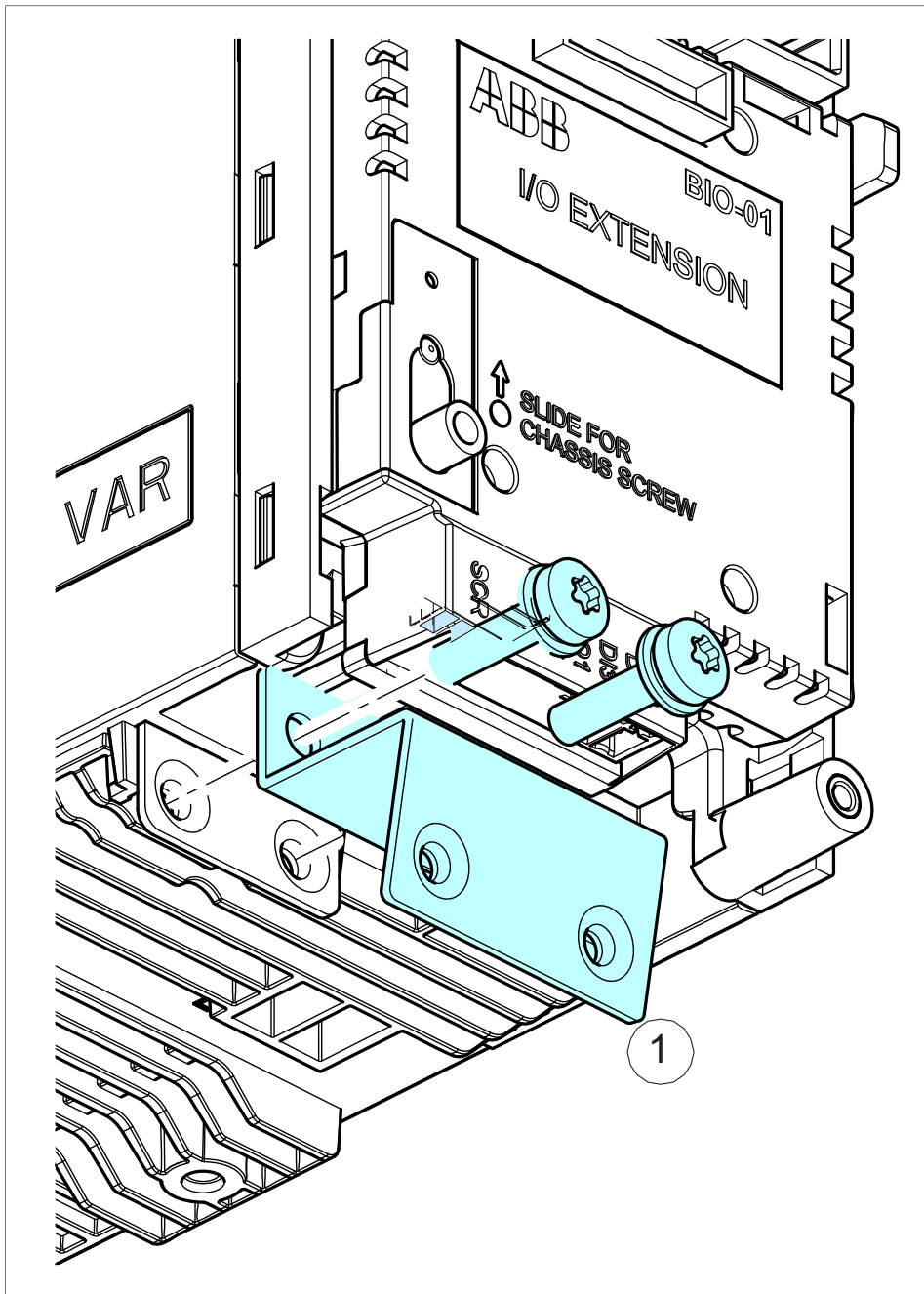

Note:

If you power up the drive before you install the BIO-01 option module or a fieldbus module, the drive gives a warning.

Electrical installation

See chapter [Electrical installation \(page 67\)](#). If you configure the inputs, set up the wiring accordingly. The BIO-01 module has removable spring clamp terminals. Use ferrules on the multistranded cables before assembly.

Sample wiring with the ABB standard macro

Terminals External sample connection	Description	Base unit	Internal connection	
Aux. voltage output and prog. digital input				
+24V	Aux. output +24 V DC, max. 200 mA	X		
DGND	Aux. voltage output common	X		
DCOM	Digital input common for all	X		
DI1	Stop (0)/Start (1)	X		
DI2	Forward (0)/Reverse (1)	X		
Digital and analog I/O extension BIO-01				
DI3	Constant frequency/speed selection			
DI4	Constant frequency/speed selection			
DI5	Ramp set 1 (0)/Ramp set 2 (1)			
DO1	Not configured			
AI1	Output frequency/speed ref. 0...10 V			
+10V	Ref. voltage +10 V DC (max. 10 mA)			
GND	Analog circuit common / DO common			
SCR	Signal cable shield / DO screen			
Safe torque off (STO)				
SGND	Safe torque off. Factory connection.	X		
IN1	Both circuits must be closed for the drive to start.	X		
IN2		X		
OUT1		X		

Start-up

After connecting the device, restart the drive for auto detection of the BIO-01 module. To configure the inputs manually, refer to the ACS560 firmware manual (3AXD50000044997[English]).

Technical data

Control connection data

For BIO-01 electrical data, see chapter [Technical data \(page 119\)](#).

Dimensions

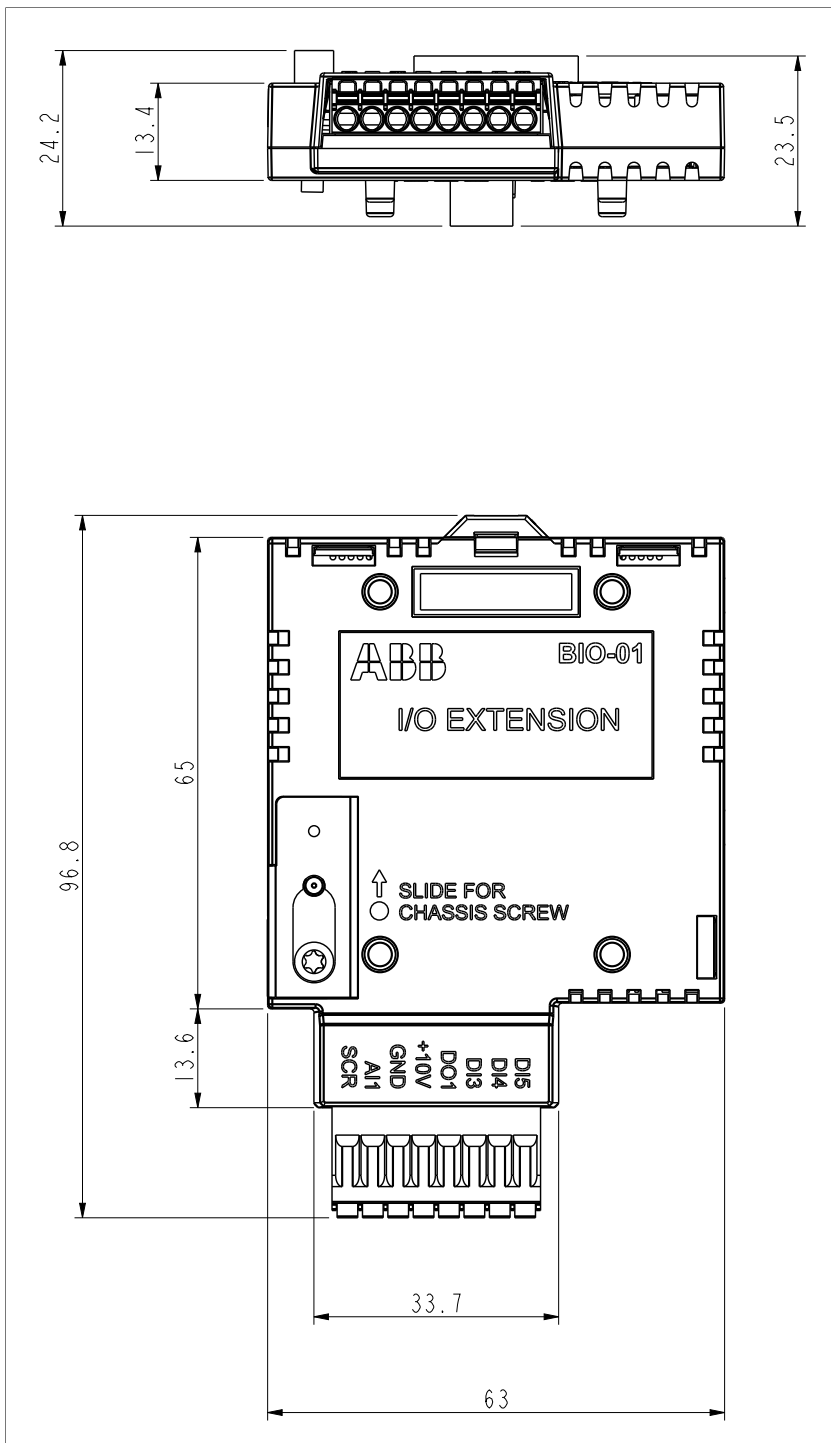

■ **CMOD-02 multifunction extension module (external 24 V AC/DC)**

Hardware description

Product overview

The CMOD-02 multifunction extension module (external 24 V AC/DC).

The extension module has an external power supply interface, which can be used to power up the drive control unit in case the drive power supply fails. If you do not need the back-up

power supply, you do not have to connect it because the module is powered from the drive control unit by default.

Note:

In frames R6...R8, you do not need a CMOD-02 module to use external 24 V AC/DC supply. The external supply is connected directly to terminals 40 and 41 on the control unit. If you want to use external 24 V supply to control unit of R0...R2 drives, contact your local ABB representative.



WARNING!

Do not connect the +24 V AC cable to the control unit ground when the control unit is powered using an external 24 V AC supply.

Layout

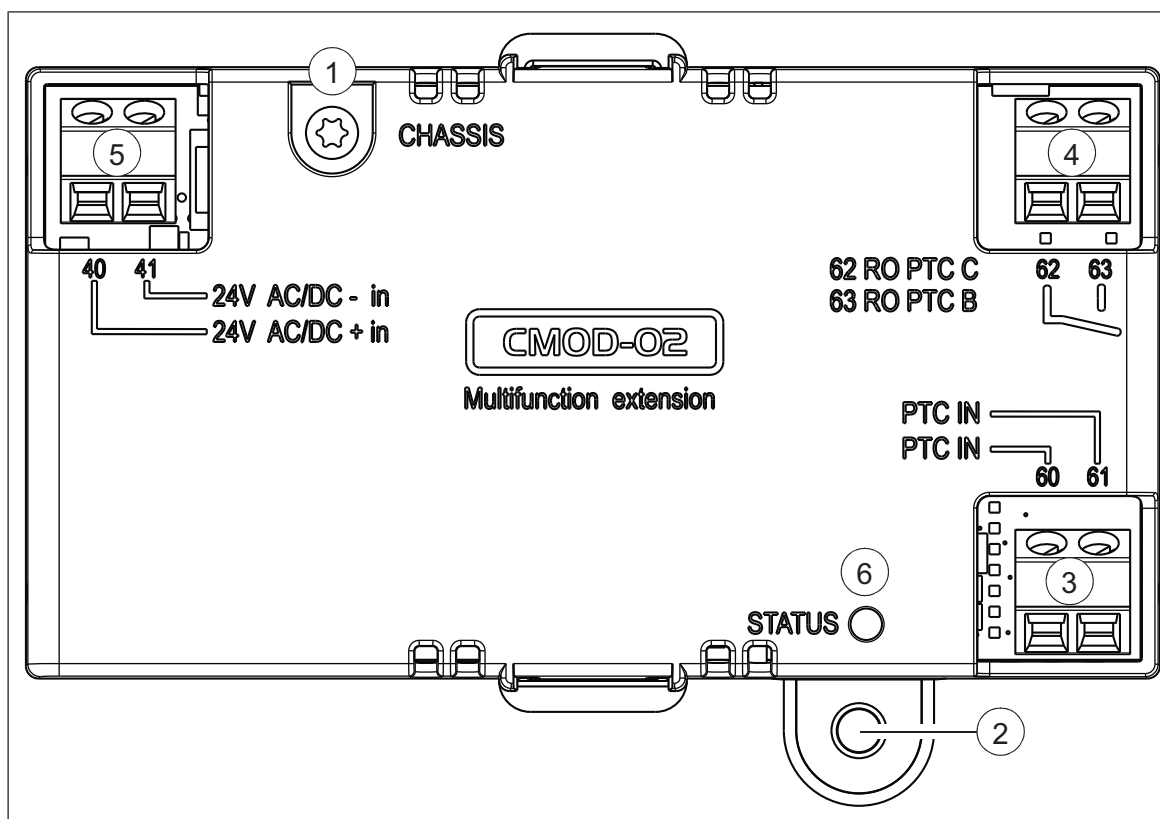

1	Grounding screw	<i>Mechanical installation (page 182)</i>
2	Hole for mounting screw	<i>Mechanical installation (page 182)</i>
3	2-pin terminal block for external power supply	<i>Terminal designations (page 183)</i>
4	Diagnostic LED	<i>LEDs (page 184)</i>

Mechanical installation

Necessary tools and instructions

Unpacking and checking the delivery

1. Open the option package.
2. Make sure that the package contains:

- CMOD-02 multifunction extension module
- mounting screw

3. Make sure that there are no signs of damage.

Installing the module

See section *Installing optional modules* in chapter *Electrical installation*.

Electrical installation



WARNING!

Obey the instructions in chapter *Safety instructions*. If you ignore them, injury or death, or damage to the equipment can occur. If you are not a qualified electrician, do not do electrical work.

Make sure that the drive is disconnected from the input power during installation. If the drive is already connected to the input power, wait for 5 minutes after disconnecting the input power.

Necessary tools and instructions

- Screwdriver and a set of suitable bits
- Cabling tools

Terminal designations

For more detailed information on the connectors, see section [Technical data \(page 184\)](#).

External power supply

The external power supply is needed only if you want to connect an external back-up power supply for the drive control unit.

Marking		Description
40	24V AC/DC + in	External 24 V (AC/DC) input
41	24V AC/DC - in	External 24 V (AC/DC) input

General cabling instructions

Obey the instructions given in chapter *Planning the electrical installation*.

Wiring

Connect the external control cables to the applicable module terminals. Ground the outer shield of the cables 360 degrees under a grounding clamp on the grounding shelf of the control cables.

Power supply connection example

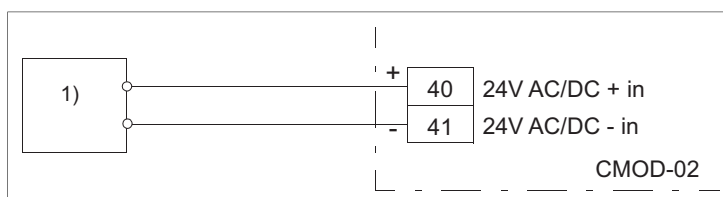



WARNING!

Do not connect the +24 V AC cable to the control unit ground when the control unit is powered using an external 24 V AC supply.

Start-up

Setting the parameters

Diagnostics

Faults and warning messages

Warning A7AB Extension I/O configuration failure.

LEDs

The extension module has one diagnostic LED.

Color	Description
Green	The extension module is powered up.

Technical data

Dimension drawing:

The dimensions are in millimeters and [inches].

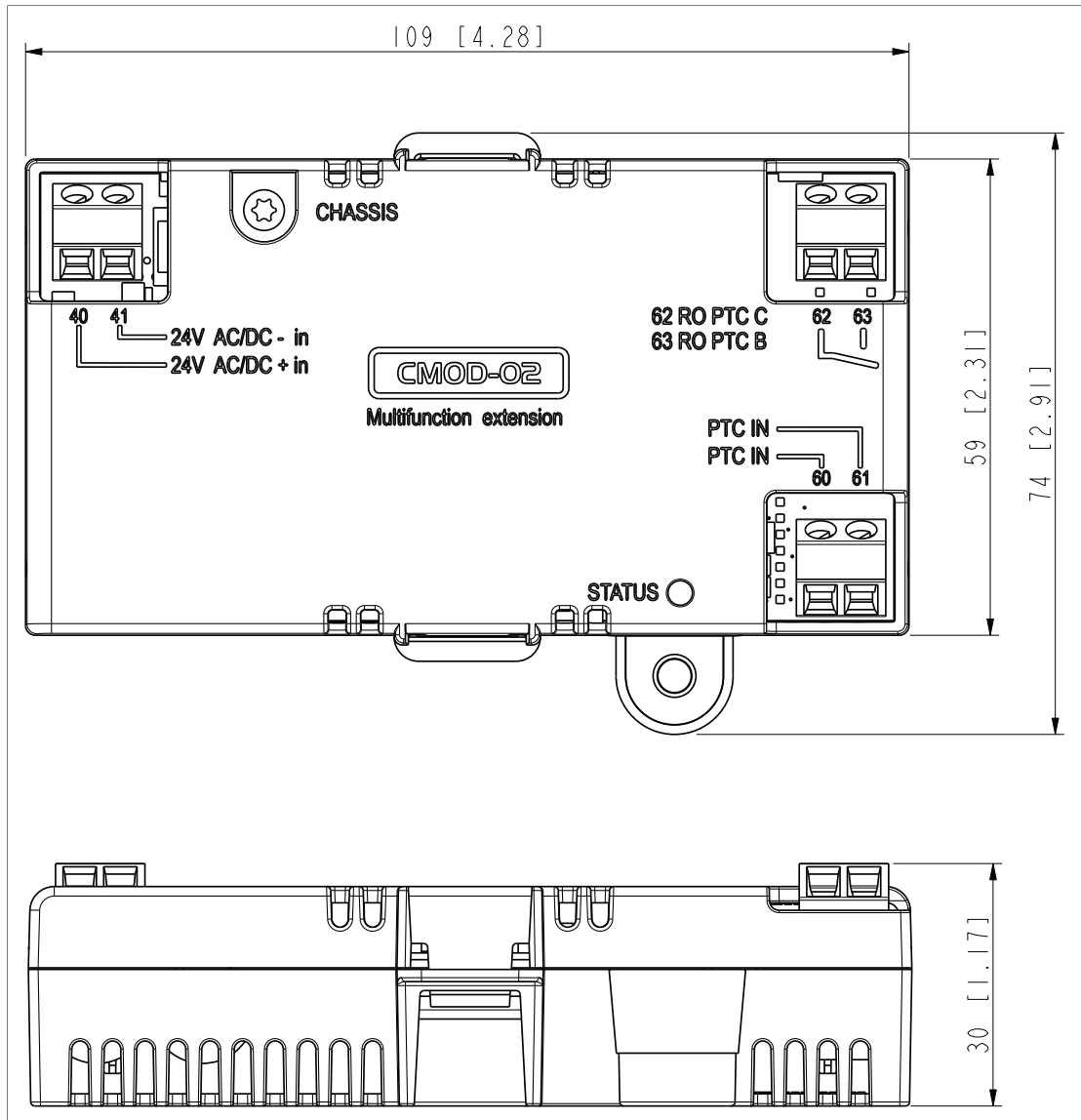

Installation: Into an option slot on the drive control unit

Degree of protection: IP20

Ambient conditions: See the drive technical data.

Package: Cardboard

Isolation areas:

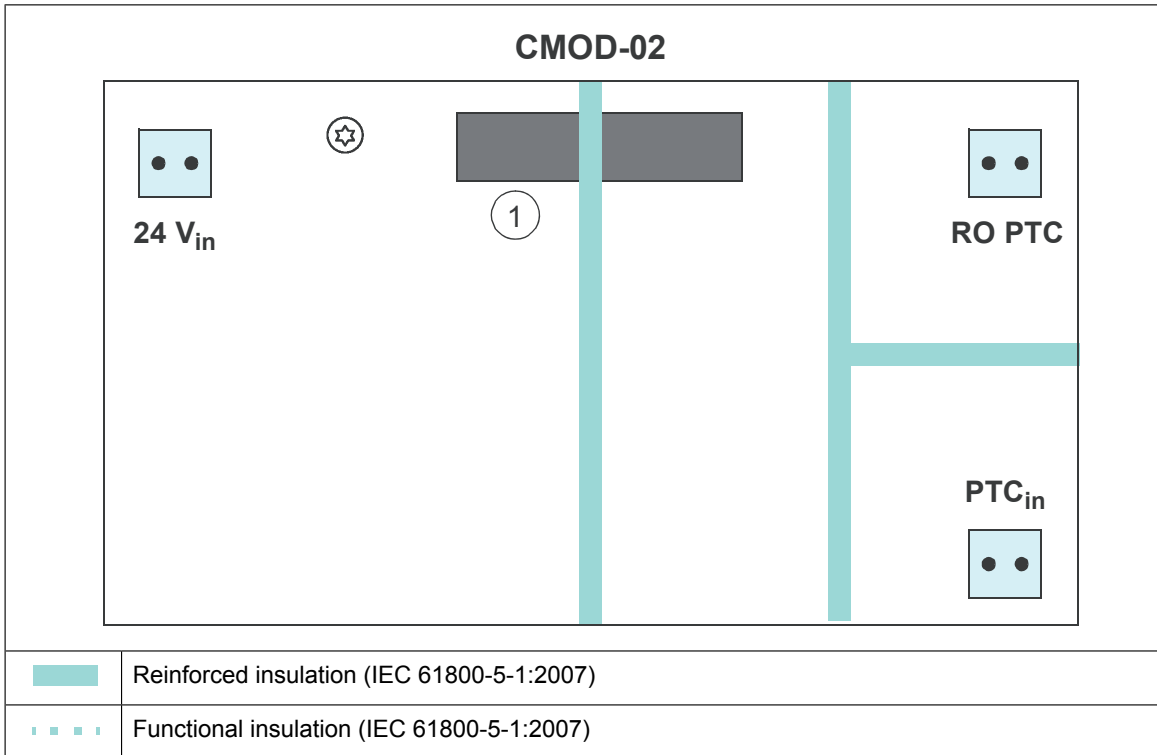

Motor thermistor connection (60...61):

- Wire size max. 1.5 mm²
- Supported standards: DIN 44081 and DIN 44082
- Number of PTC thermistor relays: 1 or 3...6 in series
- Triggering threshold: 3.6 kohm ±10%
- Recovery threshold: 1.6 kohm ±10%
- PTC terminal voltage: < 5.0 V
- PTC terminal current: < 1 mA
- Short-circuit detection: < 50 ohm ±10%

Relay output (62...63):

- Wire size max. 1.5 mm²
- Maximum contact rating: 250 V AC / 30 V DC / 5 A
- Maximum breaking capacity: 1000 VA

External power supply (40...41):

- Wire size max. 1.5 mm²
- 24 V AC / V DC ±10% (GND, user potential)
- Maximum current consumption: 25 W, 1.04 A at 24 V DC

■ **BAPO-01 power extension module**

Contents of this chapter

This chapter contains a description and technical data of the optional BAPO-01 auxiliary power extension module.

Safety instructions



WARNING!

Read the safety instructions. If you ignore them, injury or death, or damage to the equipment can occur.

Hardware description

Product overview

The BAPO-01 auxiliary power extension module (option +L534) enables the use of an external auxiliary power supply with the drive. You need an external auxiliary power supply to keep the drive on during a power outage. Connect the auxiliary voltage supply to the +24 V and DGND terminals on the drive.

If you change the drive parameters when the control board is energized with the BAPO module, force parameter saving with parameter *96.07 PARAM SAVE* by setting the value to (1) *SAVE*. Otherwise, changed data will not be saved.

Layout

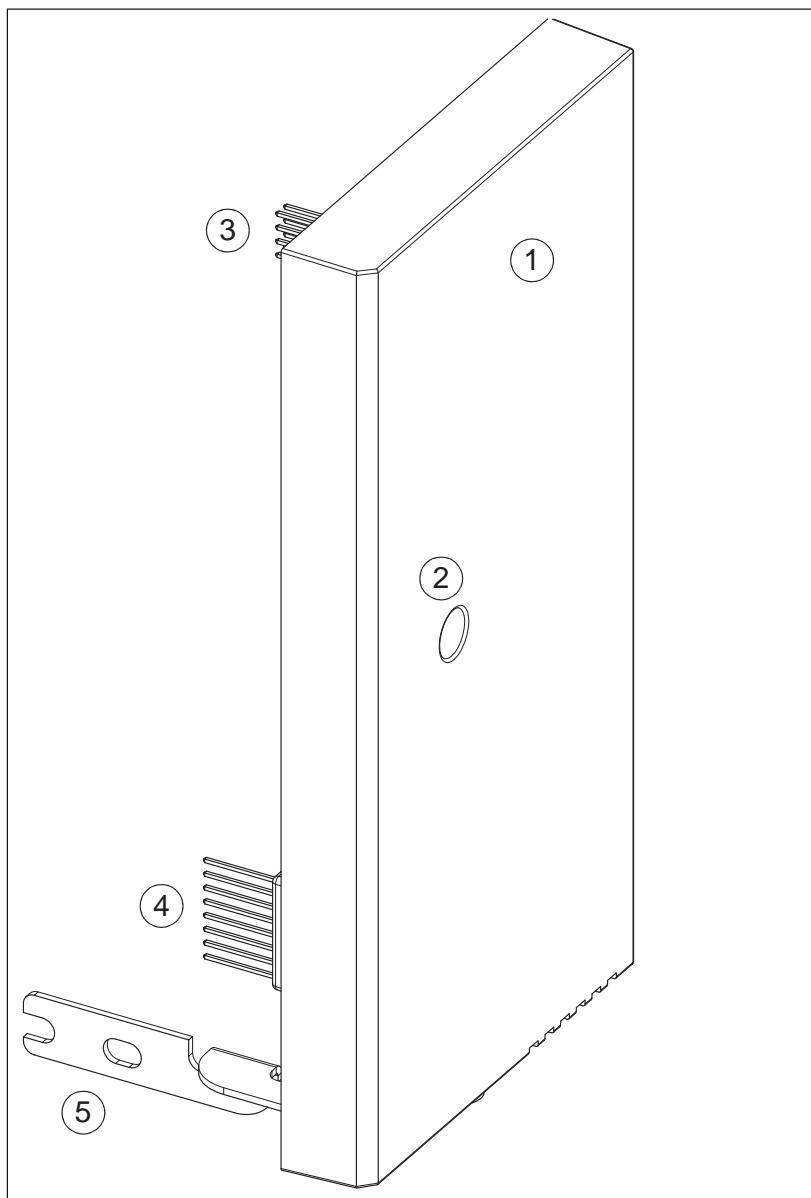

1. BAPO module
2. Locking screw hole
3. Internal X100 connector
4. Internal X102 connector
5. Grounding rail

Mechanical installation

See the electrical installation instructions.

Electrical installation

Connect the auxiliary voltage supply to the +24 V and DGND terminals on the drive. See the electrical installation instructions. The BAPO module has internal connections to provide back-up power to the control board (I/O, fieldbus).

Start-up

To configure the BAPO module:

1. Power up the drive.
2. Set the parameter *95.04 Control board supply* to 1 (*External 24V*).

Technical data

Voltage and current rating for the auxiliary power supply

+24 V DC $\pm 10\%$, max. 1000 mA (incl internal fan load).

Power loss

Power losses with maximum load 4 W.

Dimensions

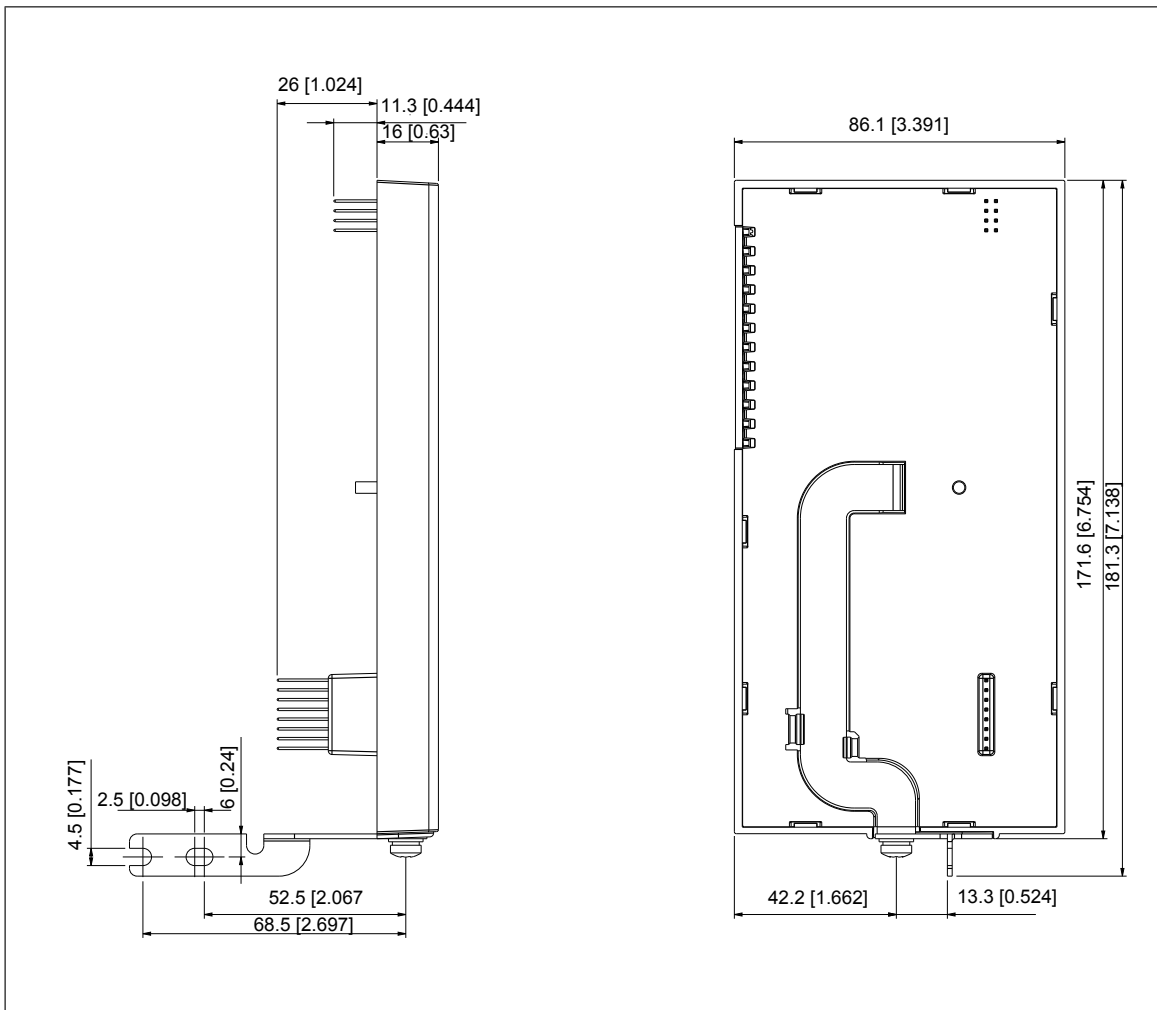



RDUM-01 blank control panel

RDUM -01 is a blank control panel cover that can be used to connect drive to a basic or assistant control panel mounted on a cabinet door.

RDUM-01 can be installed on the drive control panel slot and can be connected to the basic or assistant control panel with a RJ 45 male to male (ethernet) cable.

Layout

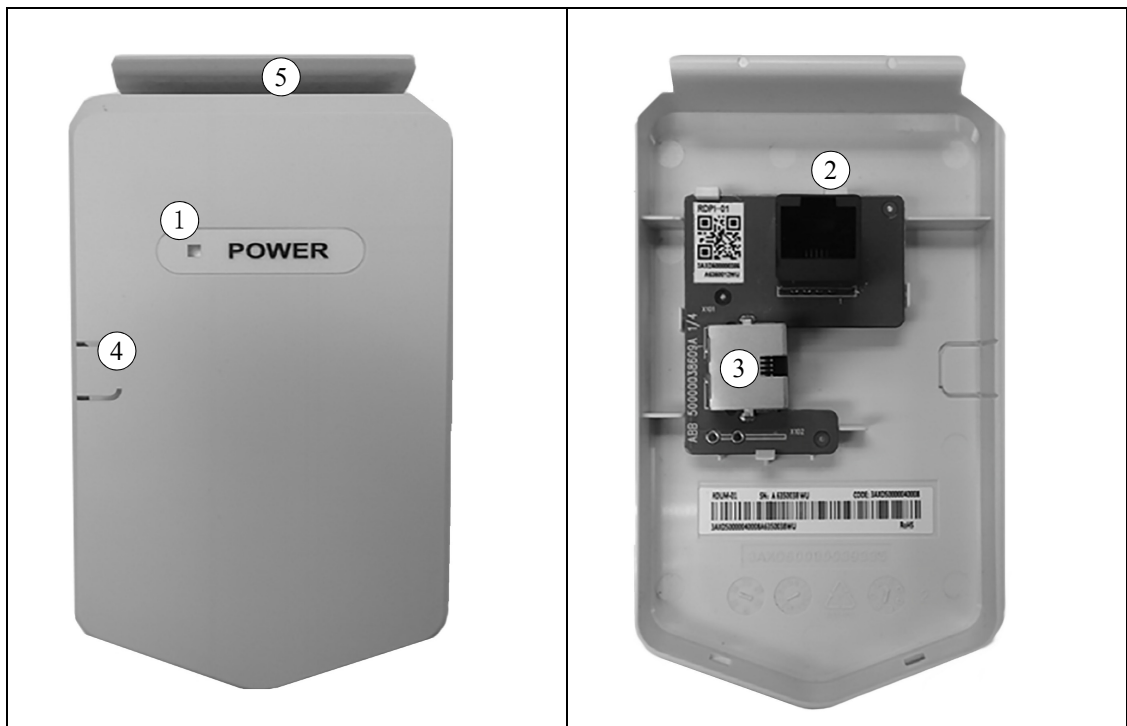

Item	Description
1	LEDs mirrored from the drive control unit
2	Connector X100 to the drive control unit
3	Connector X101 for connecting a control panel or a PC
4	Cable hole locations. Used when the cabling connected to the module is routed outside the drive.
5	Clip for attaching the module to the drive

Example: Connecting a RDUM-01 panel to an assistant or basic control panel mounted on a cabinet door

The figure below shows how to connect a remote control panel to drive through RDUM-01.

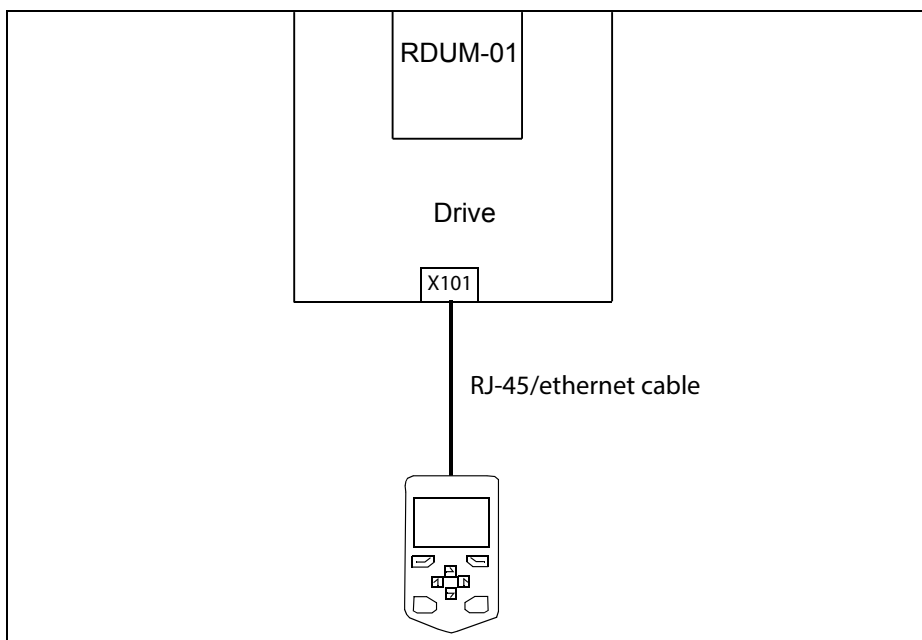

Installing assistant or basic control panel on the cabinet door

The basic panel or assistant control can be connected to the cabinet door using the screw inserts available behind the control panel.

For better aesthetics and convenience, you can install DPMP-02 surface mounting platform or DPMP-01 flush mounting panel on the cabinet door and then install the basic or assistant control panel. You can order DPMP-02 and DPMP-01 from ABB.

15

External input choke

Contents of this chapter

This chapter describes about external input chokes available for the R0...R2 (2.6A to 25A) frame sizes. In R0...R5 (33A to 293A) frame sizes, built-in DC swinging choke is provided by default. DC swinging choke reduces 20% more harmonics in partial loads due to its patented swinging choke technology and also helps in protecting the drive from input variations and reduces DC ripple content.

Why external input chokes are required?

The external input choke protects against voltage spikes and reduces harmonics in the line supply.

Specification

External input choke name	CHK-01	CHK-02	CHK-03	CHK-04	CHK-05
Rated voltage (V AC)	500	500	500	500	500
Frequency (Hz)	50	50	50	50	50
Inductance (mH)	6.37	4.61	2.7	1.475	1.13
Rated current, IRMS (A)	5	9	16	25	40
Inductance tolerance (%)	-5/+10	-5/+10	-5/+10	-5/+10	-5/+10
Cooling	Natural air	Natural air	Natural air	Natural air	Natural air

192 External input choke

External input choke name	CHK-01	CHK-02	CHK-03	CHK-04	CHK-05
Ambient temperature (°C)	55	55	55	55	55
Power loss (W)	35	50	50	80	150
Insulation class	H (180°C)	H (180°C)	H (180°C)	H (180°C)	H (180°C)
Compliance	ROHS	ROHS	ROHS	ROHS	ROHS
IP class	IP 00	IP 00	IP 00	IP 00	IP 00
Product weight, approx (KG)	2	3.6	5.4	10.3	10.8

External input choke types

Code	Name	Description
3AYN477110-CHK1A	CHK-01	For 2 .6- 4 A drives
3AYN477110-CH K2A	CHK-02	For 5 .6-7. 2A drives
3AYN477110-CH K3A	CHK-03	For 9.4 -126A drives
3AYN477110-CHK4A	CHK-04	For 17A drives
3AYN477110-CHK5A	CHK-05	For 25A drives

For choke data sheet, contact your local ABB representative (www.abb.com/searchchannels).

Mechanical dimensions

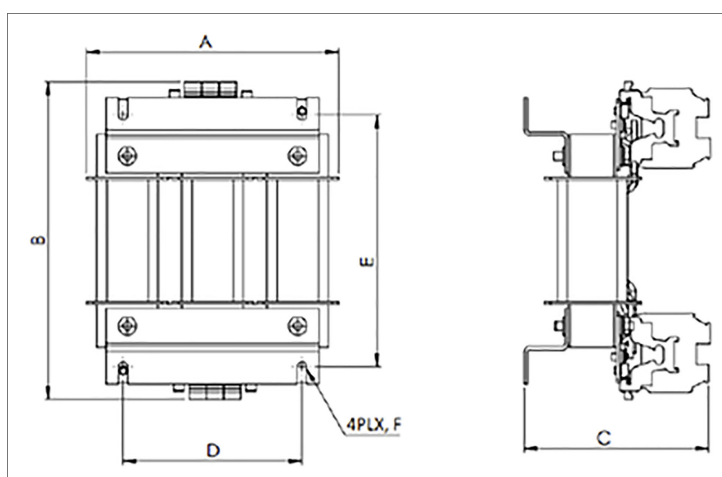

No.	Mechanical parameters	Choke type				
		CHK-01 (mm)	CHK-02 (mm)	CHK-03 (mm)	CHK-04 (mm)	CHK-05 (mm)
1	A	≤145	≤150	≤150	≤150	208±2
2	B	≤166	≤195	≤208	≤195	295±3
3	C	≤113	≤116	≤131	≤131	155±3

No.	Mechanical parameters	Choke type				
		CHK-01 (mm)	CHK-02 (mm)	CHK-03 (mm)	CHK-04 (mm)	CHK-05 (mm)
4	D	78 ±1	105±3	105±3	105±3	193±2
5	E	122 ±2	148±2	148±2	148±2	118±2
6	F	12 X 7	12 X 7	14 X 6	14 X 6	10 X 7

Specification

External input choke name	CHK-01	CHK-02	CHK-03	CHK-04	CHK-05
Rated voltage (V AC)	500	500	500	500	500
Frequency (Hz)	50	50	50	50	50
Inductance (mH)	6.37	4.61	2.7	1.475	1.13
Rated current, IRMS (A)	5	9	16	25	40
Inductance tolerance (%)	-5/+10	-5/+10	-5/+10	-5/+10	-5/+10
Cooling	Natural air	Natural air	Natural air	Natural air	Natural air
Ambient temperature (°C)	55	55	55	55	55
Power loss (W)	35	50	50	80	150
Insulation class	H (180°C)	H (180°C)	H (180°C)	H (180°C)	H (180°C)
Compliance	ROHS	ROHS	ROHS	ROHS	ROHS
IP class	IP 00	IP 00	IP 00	IP 00	IP 00
Product weight, approx (KG)	2	3.6	5.4	10.3	10.8

16

du/dt filters

Contents of this chapter

This chapter describes how to select external filters for the drive.

du/dt filters

- **Where is a du/dt filter needed?**

du/dt filter is required to reduce the additional stress on motor and motor cable insulation caused by increase in pulse voltage in the motor terminals. For information on compatibility, see section [Checking the compatibility of the motor and drive](#).

- **du/dt filter types**

Drive type ACS560-	du/dt filter type
3 phases $U_N = 400$ V (380...480 V)	
02A6-4	NOCH0016-6X
03A3-4	NOCH0016-6X
04A0-4	NOCH0016-6X
05A6-4	NOCH0016-6X
07A2-4	NOCH0016-6X
09A4-4	NOCH0016-6X
12A6-4	NOCH0016-6X
017A-4	NOCH0030-6X
025A-4	NOCH0030-6X

Drive type ACS560-	du/dt filter type
033A-4	NOCH0070-6X
039A-4	NOCH0070-6X
046A-4	NOCH0070-6X
062A-4	NOCH0070-6X
073A-4	NOCH0070-6X
088A-4	NOCH0120-6X
106A-4	NOCH0120-6X
145A-4	NOCH0120-6X
169A-4	FOCH0260-7X
206A-4	FOCH0260-7X
246A-4	FOCH0260-7X
293A-4	FOCH0260-7X

■ **Description, installation and technical data of the FOCH filters**

See *FOCH du/dt filters hardware manual* (3AFE68577519 [English]).

■ **Description, installation and technical data of the AOCH and NOCH filters**

See *AOCH and NOCH du/dt filters hardware manual* (3AFE58933368 [English]).

Further information

Product and service inquiries

Address any inquiries about the product to your local ABB representative, quoting the type designation and serial number of the unit in question. A listing of ABB sales, support and service contacts can be found by navigating to www.abb.com/searchchannels.

Product training

For information on ABB product training, navigate to new.abb.com/service/training.

Providing feedback on ABB manuals

Your comments on our manuals are welcome. Navigate to new.abb.com/drives/manuals-feedback-form.

Document library on the Internet

You can find manuals and other product documents in PDF format on the Internet at www.abb.com/drives/documents.



www.abb.com/drives



3AXD50000044998E