

IRB 390 FlexPacker®

Opening new possibilities for ultra-fast high payload picking and packing



reddot winner 2022

The IRB 390 is a 4 and 5 axis delta robot that is up to 35 percent faster and offers a 45 percent larger working volume for enhanced productivity. Its 5-axis capability increases application flexibility for secondary packaging, making it ideal for Retail Ready Packaging (RRP) where products are placed vertically.

Faster, with a higher payload and more flexibility due to its delta form, the new IRB 390 FlexPacker is ideal for customized packaging, vertical packing and high-speed, high-variation sorting, as well as on demand order picking in logistics and e-commerce fulfillment centers.

Key benefits

- Fast 5-axis motion makes it ideal for Shelf Ready Packaging (SRP) and Retail Ready Packaging (RRP) where products are placed vertically.
- Ability to vertically orient goods means a single manipulator can be used for top load and Shelf Ready Packing with no need for additional equipment.
- 15 kg payload offers high flexibility in materials handling, packaging and sorting applications aimed for heavy products, complex multi-head grippers and full layer packing.
- NSF H1 Food Grade Lubricants and FDA compliant, suitable for use in hygienic sensitive surfaces.
- 35 % faster and offers 45 % larger working volume* for enhanced productivity, enabling products to be picked from high speed systems running at up to 100 m/min and placed into cases, trays, crates or other packaging formats.
- Can be combined with ABB's IRB 360 FlexPicker® and PickMaster® Twin to provide a complete packing solution for pre-sorting and group packing applications.

*compared to IRB 360-8/1130

Game changing in packaging with class-leading performance

The demand for fast, flexible and accurate goods handling are met by the IRB 390. With its class-leading speed, working range and payload handling capabilities, the IRB 390 can be used to sort and pick multiple products of varying sizes and shapes up to 15 kg, enabling increased throughput per robot. The five axes version of the IRB 390 can be used to vertically orient boxes and parcels from lines running at up to 100 meters per minute and place them into cases, trays, crates or other packaging formats.

This combination of performance and flexibility enables the IRB 390 to be deployed in secondary packaging and higher payload applications across a variety of industries including:

- Food and Beverage
- Pharmaceutical
- Medical products
- Personal care
- Consumer Packaged Goods
- Logistics

Applications include:

- Picking, packing, secondary packaging
- Materials handling and sorting
- Bin picking
- Singulation for logistics, parcel picking and sorting and on demand carton box packing

Specification

Robot version	Diameter (mm)	Payload (kg)	No. Axes
IRB 390 - 15/1300	1300	15	4
IRB 390 - 10/1300	1300	10	5
Supplementary load	on upper arm on lower arm	0.5 kg 0.15 kg	
Protection	IP67		
Mounting	Inverted		
Controller	IRC5, OmniCore V250XT, V400XT		

Performance (According to ISO 9283)

	IRB 390 - 15/1300	IRB 390 - 10/1300
Pose repeatability, RP [mm]	0.02	0.07
Pose stabilization time, PSt [s] within 0.1 mm of the position	0.14	0.30

Cycle times (s)

25/305/25mm cycle	1 kg	10 kg	15 kg
IRB 390 - 15/1300	0.42	0.52	0.57
IRB 390 - 10/1300	0.49	0.59	-
90/400/90 mm cycle	1 kg	10 kg	15 kg
IRB 390 - 15/1300	0.59	0.74	0.81
IRB 390 - 10/1300	0.69	0.83	-
200/700/200 mm cycle	1 kg	10 kg	15 kg
IRB 390 - 15/1300	0.89	1.09	1.19
IRB 390 - 10/1300	1.04	1.23	-

Incl. 0.035 s dwell time at pick and place

Physical

	IRB 390 - 15/1300	IRB 390 - 10/1300
Weight	133	148

Environment

Ambient temperature	IRB 390 manipulator +5 °C to +50 °C Relative humidity max. 95 %	
Noise level	< 68 dB(A)	
Safety	Double circuits with supervision, emergency stops & safety functions, 3 position enabling device	

Hygienic Attributes

Food grade lubrication	Gearbox oil Grease behind exposed seals	
FDA compliant material	All exposed surfaces	

Working range (mm)

IRB 390 - 15/1300

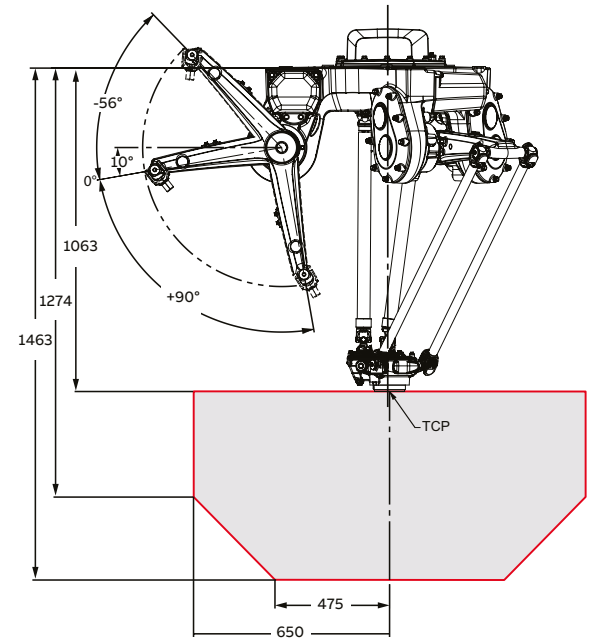

IRB 390 - 10/1300

