

GRID FEEDING MONITORING RELAYS

Grid feeding monitoring relay CM-UFD.M22M with Modbus RTU and ABB Ability™ EDCS connectivity

Increase network stability with high-performance grid and system protection, tested for CEI 0-21

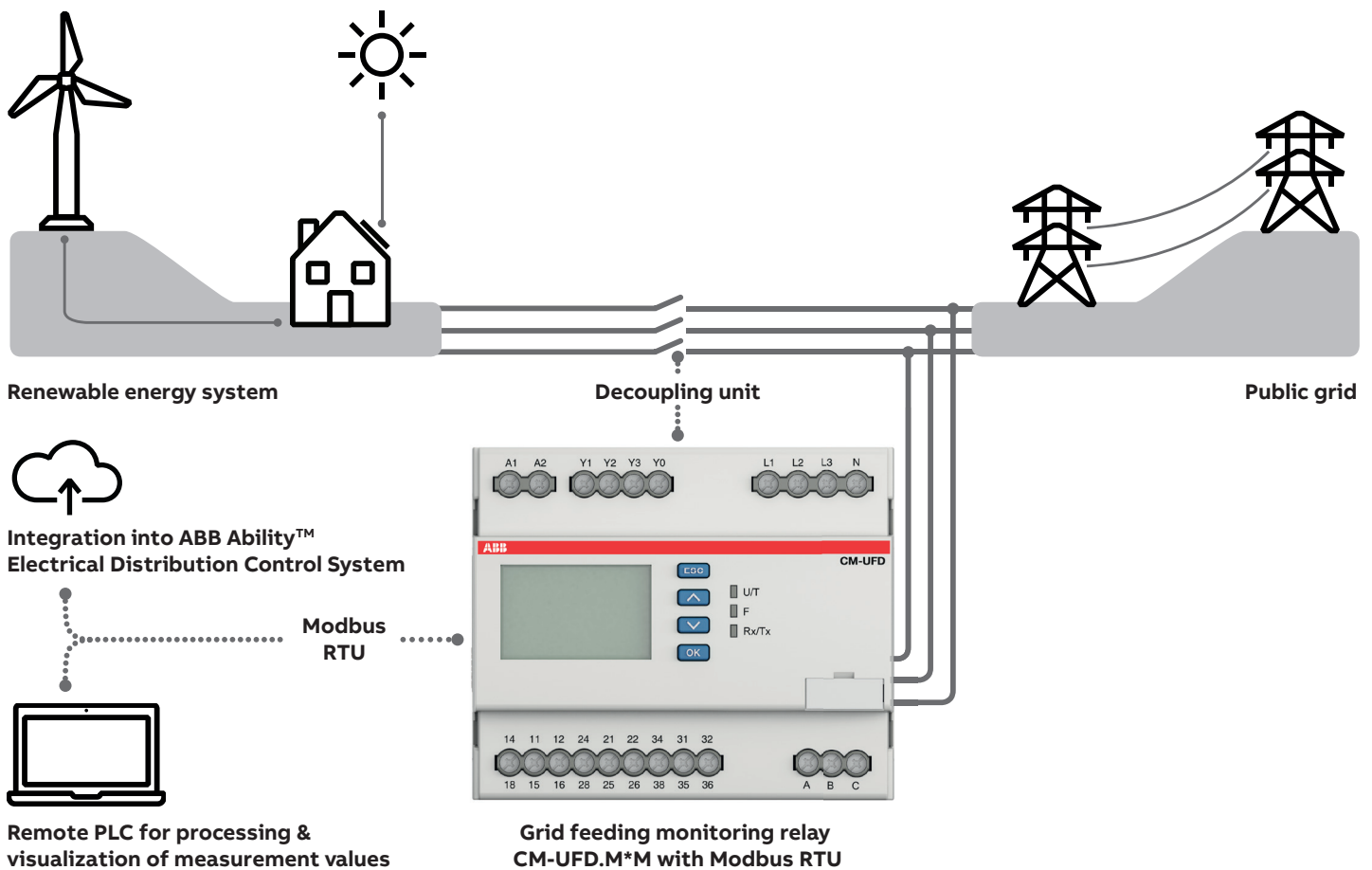

Application

ABB's CM-UFD.M22M with Modbus RTU is a multifunctional grid feeding monitoring relay that sits between the renewable energy system and the public grid. The innovative relay guarantees grid stability and prevents blackouts. If the public grid's voltage or frequency moves out of the permitted ranges, the device uses a decoupling unit (e.g. contactor or breaker Tmax XT) to separate the renewable energy system from the public grid.

Functionality

ABB's CM-UFD.M22M relay provides a range of monitoring functions in accordance with CEI 0-21. The unit detects over- and undervoltage (10-minutes average value, voltage increase and decrease protection) as well as any changes in grid frequency (frequency increase and decrease protection). The rate of change of frequency (ROCOF) as well as vector shift monitoring can be easily configured.

Advantages

- Highly accurate measurement and setting
- Modbus RTU communication interface
- Functional safety - single fault tolerance
- Clear multiline, backlit LCD display
- Intuitive and user-friendly menu

- Event storage built in
- Pre-setting meets CEI 0-21
- Type tested for CEI 0-21 by TÜV SÜD
- Integrate the CM.UFD.M*M range into ABB Ability™ EDCS



Services and training

Cut installation time by up to 60%

There's no need to learn every possible adjustment and its effects on your system – ABB's trained staff supports your business and answers your technical questions promptly.



Easy-to-install

Commission & configure up to 60% faster

Simple instructions, presets for local grid feeding standards, and ABB's intuitive menu structure make installation quicker. Commissioning and troubleshooting errors are prevented.



Optimum interface

Reduce downtime by up to 70%

Operate the device via LCD display or remotely with the Modbus RTU. Users are informed immediately in case of an event in the public grid. Redundant microcontrollers ensure reliable measuring values and tripping.



Connected to ABB Ability™



01 CM-UFD.M22M with Modbus RTU

The CM-UFD.M22M's display, communication interface, pre-setting and Modbus RTU ensure that installation and configuration times are reduced by up to 60%.



Communication interface

The Modbus RTU enables control commands like remote tripping and convenient remote data processing. It also provides status information and actual process values.



Pre-set according to CEI 0-21

In conformity with the CEI 0-21 standard, the CM-UFD.M22M relay can be used in all low voltage plants and in medium voltage plants.



Type-tested

To ensure reliability and compliance to the local standard the CM-UFD.M22M is type tested by the third party authority TÜV SÜD.

Ordering details

Type	Rated control supply voltage	Measuring range	Order code
CM-UFD.M22M	24-240 V AC/DC	L-L: 0-540 V AC / L-N: 0-312 V AC	1SVR560731R3700

ABB STOTZ-KONTAKT GmbH
Eppelheimer Straße 82
69123 Heidelberg, Germany

abb.com/lowvoltage



We reserve the right to make technical changes or modify the contents of this document without prior notice. With regard to purchase orders, the agreed particulars shall prevail. ABB AG does not accept any responsibility whatsoever for potential errors or possible lack of information in this document.

We reserve all rights in this document and in the subject matter and illustrations contained therein. Any reproduction, disclosure to third parties or utilization of its contents – in whole or in parts – is forbidden without prior written consent of ABB AG. Copyright © 2017 ABB. All rights reserved.