

Annunciator Unit

SACO 64 D4

Product Guide

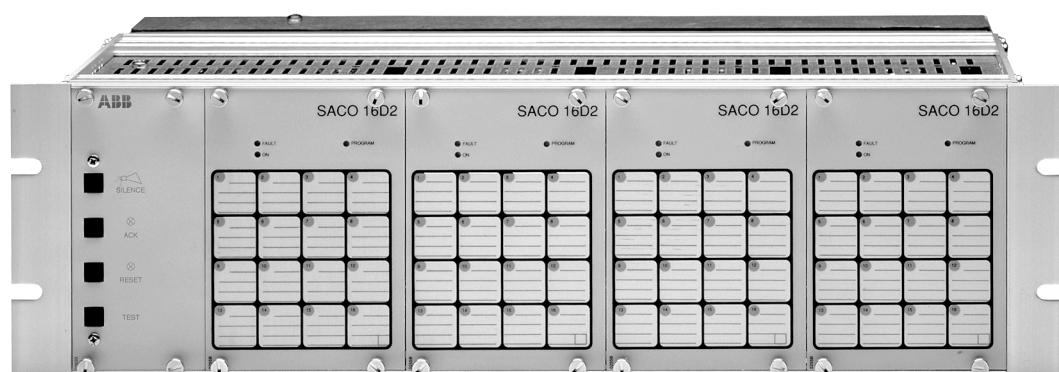

Features

- Self-contained microprocessor-based annunciator unit with 64 alarm channels
- Alarm channels activated by normally open or normally closed contact
- Small and large stand-alone annunciator applications
- Large centralized or distributed annunciator systems with event reporting
- Fully field-programmable by means of a portable programming module or via the serial interface
- Sixteen output relays, i.e. 14 for group realarms, one for an audible device and one for the self-supervision system
- Extensive communication with superior systems via the serial interface and the SPA bus
- High immunity to electrical and electromagnetic interference
- Sophisticated hardware and software self-supervision system for maximum operational reliability even under the most demanding environmental conditions
- Powerful software support for parameterization of the annunciator units via the serial interface
- Member of the SPACOM product family and ABB's Distribution Automation system
- CE marking according to the EC directive for EMC

Application

The annunciator unit SACO 64D4 is used in a variety of applications requiring supervision of alarm and signalling contacts in power plants, substations and industrial process installations. The alarm unit is also approved for use in off-shore installations and marine applications. Further, the annunciator unit can be used in any application where on/off signals are to be supervised.

The annunciator unit provides immediate fault recognition, fault identification and visual and audible alarm in an abnormal process situation. The annunciator unit also provides a means for subsequent fault analyses,

which means that corrective measures can be carried out without delay and full control of the process can be maintained.

The annunciator units can be used as independent stand-alone units, or several units can be interconnected and connected to printers, terminals, etc. to form complete supervision, event sequence reporting and data acquisition systems. The maximum annunciator system capacity is 560 channels in one system (SACO 148 D4) and the resolution of the time marking is 10 milliseconds.

The annunciator unit is a member of SPACOM, the ultimate integrated secondary equipment system for power systems.

Design

The annunciator unit is composed of ten modules, i.e. four alarm annunciator modules, four input/output modules, a connection module and a power module, housed in a rugged 19 inch subrack, height 3U (~133 mm). The annunciator units are normally mounted in 19 inch cabinets, but they can also be panel-mounted. In the latter case the annunciator units can be provided with a raising frame, which reduces the depth behind the panel by 40 mm.

Each alarm annunciator module includes 16 alarm channels. The channels are activated by normally open or normally closed process contacts. The required 48 V dc contact circuit voltage is generated and supervised by the annunciator unit. Each channel can separately be assigned a start delay from 5 ms to 160 s.

On activation of a channel the visual indicator of the channels starts blinking. One of five standardized blinking systems according to ISA and DIN can be selected by the operator at commissioning. When several annunciator units are interconnected the total system works as a whole, which means that blinkings are synchronized, alarm signals from different subracks can be routed to the same group alarm output relay, etc.

Each annunciator module is provided with an event register, which stores the last nine events of the module in chronological order. The event register can be read via the serial interface.

The standard annunciator unit SACO 64D4 is provided with 16 output relays, of which 14 normally are used as group alarm output relays, one is used for the control of a buzzer and one as alarm output relay for the self-supervision system. If more output relays are needed an additional relay subrack type SACO 128R4 can be used. The maximum capacity of the relay subrack is 128 relays. If additional grouping possibilities are needed the alarm signals from the SACO 64D4 can be wired via a grouping unit type SACO 64C5.

When the total annunciator system includes several SACO 64D4 units and the units are interconnected using wires type SWIR one of the units can be provided with a reset/test push-button module SWDM 3A1 the other being provided with a blank front plate.

Data communication

The annunciator unit is provided with a serial interface on the rear panel. By means of a bus connection module type SPA-ZC 17/S or SPA-ZC 21/S the unit can be connected to the fibre-optic SPA bus. The bus connection module type SPA-ZC 21/S is powered from the host unit, whereas the bus connection module SPA-ZC 17/S is provided with a built-in power unit, which can be fed from an external secured power source. The unit communicates with higher-level data acquisition and control systems over the SPA bus.

Self-supervision

The annunciator incorporates a sophisticated self-supervision system which increases the availability of the device and the reliability of the system. The self-supervision system continuously monitors the hardware and the software of the unit. The system also supervises the operation of the auxiliary supply module and the level of the electronics' voltages generated by the module.

If a permanent fault is detected, the fault indicator on the front panel of the faulty module is lit, the output relay of the self-supervision system operates and the outputs are blocked.

Auxiliary supply voltage

The auxiliary supply of the relay is obtained from an internal plug-in type power supply module. Two auxiliary power module types are available: type SWSM 220A48 with two inputs, 19...70 V dc and 80...265 V and type SWSM 220A220, also with two inputs, 80...265 V dc and 80...265 V ac/dc. The power supply module forms the internal voltages required by the annunciator.

Technical data

Table 1: Alarm channels

Alarm channels per annunciator unit, max.	64 channels
Type of contact types or signal types	Make contact (default) Break contact Rising edge Falling edge
Field contact voltage	48 V dc $\pm 20\%$
Loop current of closed field contact circuit	4 mA $\pm 20\%$
Channel input and reset delay time, field-selectable values	5 ms, 20 ms (default), 100 ms, 1 s, 5 s, 20 s, 60 s or 160 s. (Other values are possible via the serial communication.)

Table 2: External control input

Audible device reset	Make contact
Alarm acknowledge	Make contact
Channel reset	Make contact
Remote testing	Make contact
Local control	Make contact
Remote control	Make contact
The control voltage provided by the annunciator unit	48 V dc $\pm 20\%$

Table 3: Output relays

Group alarm outputs	16 contacts
Parallel lamp reflash outputs	64 relays (with SACO 128 R4)
Field contact follower output x12, x18, x19, x20	64 relays (with SACO 128 R4)
Group alarm reflash outputs x21, x22, x23, x24	64 relays (with SACO 128 R4)
Audible device output	1 contact
Self-supervision output	1 contact
Output contact type	make (by soldering a jumper also break)
Contact ratings	3 A/250 V, 50 Hz
Contact breaking capacity of circuit L/R ≤ 40 ms and 48/110/220 V dc	1 A/0.25 A/0.15 A

Table 4: Data communication

Transmission mode	Fibre-optic serial bus	
Coding	ASCII	
Data transfer, selectable	4800 or 9600 Bd	
Electrical/optical bus connection module, powered from the host unit	for plastic core cables	SPA-ZC 21BB/S
	for glass fibre cables	SPA-ZC 21MM/S
Electrical/optical bus connection module, powered from the host unit or from an external power source	for plastic core cables	SPA-ZC 17BB/S
	for glass fibre cables	SPA-ZC 17MM/S

Table 5: Auxiliary supply modules

Type of module	SWSM 220A48	Supply 1	19...70 V dc
		Supply 2	80...265 V ac/dc
	SWSM 220A220	Supply 1	80...265 V dc
		Supply 2	80...265 V ac/dc
	Power consumption		~20 W

Table 6: Tests and standards

Test voltages	- alarm and acknowledge/reset inputs to frame - output relay contacts to frame - auxiliary supply circuits to frame - inputs, outputs and supply circuits between themselves	
	Dielectric test voltage (IEC 60255-5)	2 kV, 50 Hz, 1 min
	Impulse test voltage (IEC 60255-5)	5 kV, 1.2/50 μ s, 0.5 J
Disturbance tests	HF test voltage (IEC 60255-6)	2.5 kV, 1 MHz
Environmental conditions	Ambient service temperature range	-10...+55°C
	Ambient transport and storage temperature range	-40...+70°C
	Long term damp heat withstand (IEC 60068-2-3)	<95%, +40°C, 56 d/a
	Degree of protection by enclosure when panel-mounted	IP 40
	Weight	~8.1 kg

Block diagram

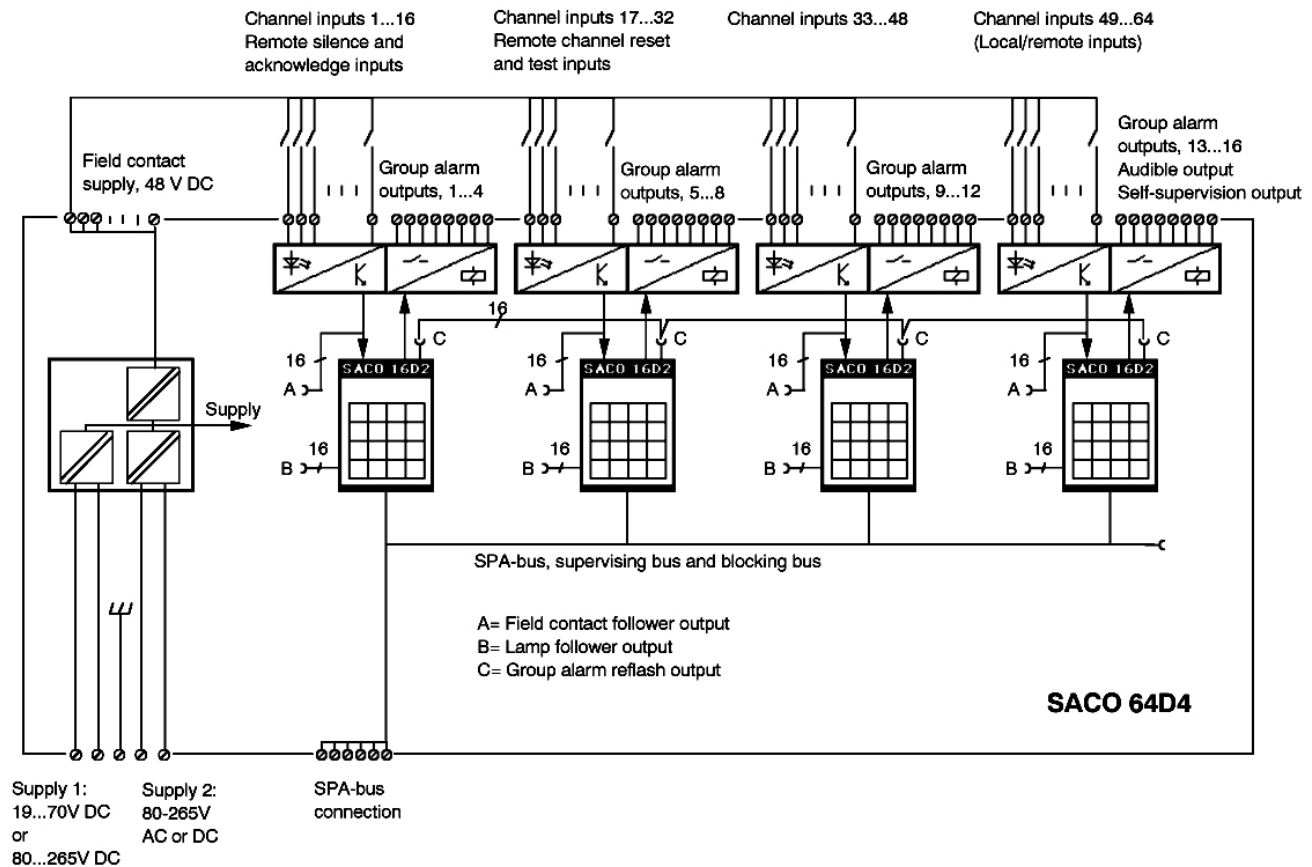

Fig. 1 Block diagram

saco64d4_block

Mounting and dimensions

19" subrack

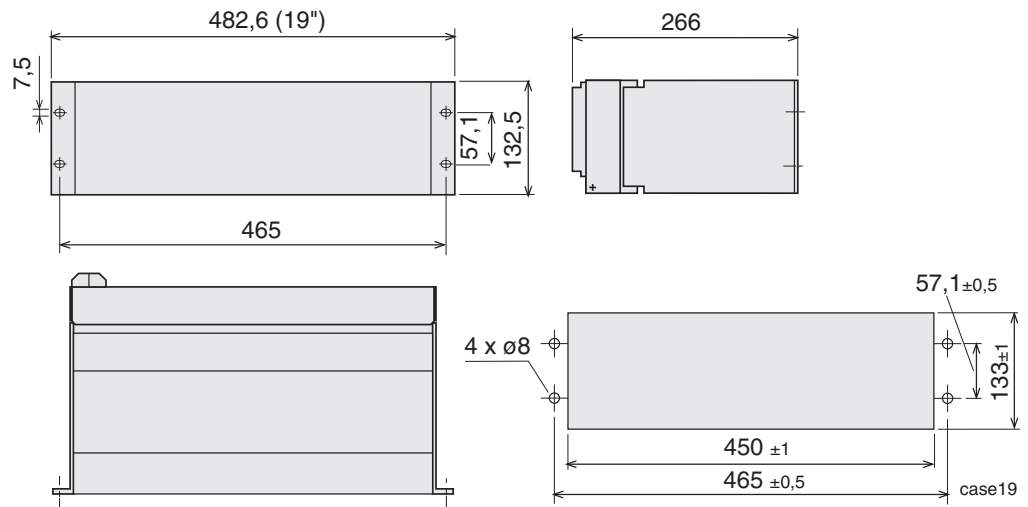

Fig. 2 Dimensions (in mm) and panel cut-out for flush mounting

Panel mounting

The annunciator can also be flush mounted in doors and panels. The relevant panel cut-out and drilling pattern for the fixing screws are illustrated above.

Ordering

When ordering, please specify:

Ordering information	Ordering example
1. Type designation and quantity	SACO 64D4, 5 pieces
2. Order number	RS 811 644-BA
3. Auxiliary voltage	$U_{aux1} = 110 \text{ V dc}$, $U_{aux2} = 220 \text{ V ac}$
4. Accessories	Reset/test push-button unit SWDM 3A1, RS 962 031-AA, 5 pieces
5. Special requirements	-

Order numbers

Annunciator units without reset/test push-button unit SWDM 3A1	
Annunciator unit SACO 64D4-0, no channels	RS 811 640-AA, -BA
Annunciator unit SACO 64D4-1, incl. 16 channels	RS 811 641-AA, -BA
Annunciator unit SACO 64D4-2, incl. 32 channels	RS 811 642-AA, -BA
Annunciator unit SACO 64D4-3, incl. 48 channels	RS 811 643-AA, -BA
Annunciator unit SACO 64D4, incl. 64 channels	RS 811 644-AA, -BA
Reset/test push-button unit SWDM 3A1	RS 962 031-AA
Programming unit SACO 16PM	RS 891 071-AA
The last two letters of the order number indicate the auxiliary voltage U_{aux} of the annunciator unit as follows:	-AA: input 1 = 80...265 V dc, input 2 = 80...265 V ac/dc (module SWSM220A220)
	-BA: input 1 = 19...70 V dc, input 2 = 80...265 V ac/dc (module SWSM220A48)

References

Additional information

User's manual "Annunciator unit SACO 64D4"	1MRS 752014-MUM
User's manual "Annunciator unit SACO 16D1"	1MRS 750944-MUM
User's manual "Annunciator unit SACO 64D3"	1MRS 751354-MUM



ABB Oy
Distribution Automation
P.O. Box 699
FI-65101 Vaasa, FINLAND
Tel +358 10 22 11
Fax +358 10 224 1094
www.abb.com/substationautomation