

# S200MUC Datasheet

Supplementary protection acc. to CSA C22.2 No.235 / UL1077

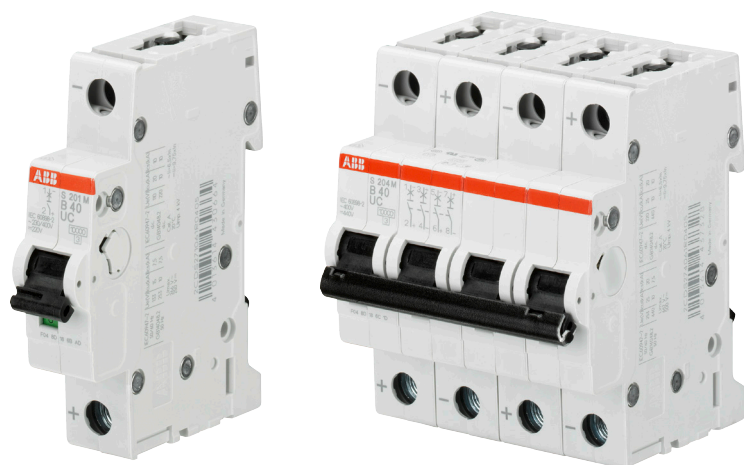

The miniature circuit breaker S200MUC extends the established ABB System pro M compact® product range with an MCB for DC and AC applications. The S200MUC impresses with its performance range and the accordingly large amount of approvals. Its high inbuilt short circuit breaking capacity across the entire model line, its flexible AC and DC application and its approval and compliance in accordance with all major international and local standards make it truly unique.

01 S201MUC / S203MUC  
miniature circuit breakers

## Features

- High performance MCB with 10 kA interrupting capacity in DC acc. to UL 1077 / CSA 22.2 No. 235
- Certified up to  $I_n = 63$  A
- 480Y/277 Vac systems
- 250 Vdc 1p / 500 Vdc 2p+
- Clear contact position indication in red/green ("real CPI")
- Laser printing provides clear product information on device
- Robust thermoplastic housing material for better protection against external influences
- Unique, patented twin terminal for wiring up to 35 mm<sup>2</sup> with captive screws
- All current System pro M compact® accessories can be combined easily with the new model line

## Standards and approvals

### Standards

UL 1077  
CSA 22.2. No. 235  
IEC/EN 60947-2, 60898-2

### Approvals

UL	US
CSA	CA
VDE	DE
CCC	PRC
GL	DE
BV	FR
LRS	GB
DNV	NO
RINA	IT
SABS	SA
CCS	PRC
RMRS	RU
GOST	RU
GOST fire	RU
IMQ	IT
KEMA	NL

# Miniature Circuit Breaker S200MUC

## Technical data

<b>General data</b>	
Standards	UL 1077, CSA 22.2 No. 235, IEC/EN 60947-2, IEC 60898-2
Poles	1P, 2P, 3P, 4P
Rated current $I_n$	0.5 - 63 A
Rated frequency $f$	50/60 Hz
Tripping characteristics	K, Z
<b>UL / CSA</b>	
Rated voltage	1P: 277 Vac (250 Vdc) 2P+: 480Y / 277 Vac (500 Vdc)
Short-circuit current rating (SCCR)	6 kA (AC) / 10 kA (DC)
Application	Suppl. prot., for general use. TC1, OLO, SC:U1
Reference temperature for tripping characteristics	25 °C
Electrical endurance	6,000 ops. (AC), 1 cycle (1s.-ON, 9s.-OFF)
<b>Mechanical data</b>	
Housing	Insulation group I, RAL 7035
Toggle	Insulation group II, black, sealable
Contact position indication	Real CPI (green OFF / red ON)
Protection degree acc. to EN 60529	IP20, IP40 in enclosure with cover
Mechanical endurance	20,000 ops.
Shock resistance acc. to IEC/EN 60068-2-27	25 g - 2 shocks - 13 ms
Vibration resistance acc. to IEC/EN 60068-2-6	5g - 20 cycles at 5...150...5 Hz with load 0.8 $I_n$
Environmental conditions acc. to DIN EN 60068-2-30	28 cycles with 55 °C/90-96 % and 25 °C/95-100%
Ambient temperature	-25 ... +55 °C
Storage temperature	-40 ... +70 °C
<b>Installation</b>	
Terminal	Failsafe bi-directional cylinder-lift terminal
Cross section of conductors (top/bottom)	4...6 AWG
Torque	2.8 Nm 25 in-lbs.
Screw driver	No. 2 Pozidrive
Mounting	On DIN rail 35 mm, acc. to EN 60715 by fast clip
Mounting position	any
Supply side	Please note polarity of device
<b>Dimensions and weight</b>	
Mounting dimensions acc. to DIN 43880	Mounting dimension 1
Pole dimensions in mm (H x D x W)	85 x 69 x 17.5
Pole weight	approx. 125 g
<b>Combinations with auxiliary elements</b>	
Integrated auxiliary switch	No
Signal contact/auxiliary switch, shunt trip	Yes
Undervoltage release	No Undervoltage release

# Miniature Circuit Breaker S200MUC

## Tripping characteristics

1) The thermal releases are calibrated to a nominal reference ambient temperature of 25 °C. In the case of higher ambient temperatures, the current values fall by approx. 6 % for each 10 K temperature rise.

2) The indicated tripping values of electromagnetic tripping devices apply to a frequency of 50/60 Hz. The thermal release operates independent of frequency.

3) As from operating temperature (after  $I_1 > 1h$ , as applicable, 2 h)

### Tripping characteristics

Acc. to	Tripping characteristics	Rated current	Thermal release <sup>1)</sup>		Tripping time	Electromagnetic release <sup>2)</sup>	
			Conventional non-tripping current	Conventional tripping current		Range of instantaneous tripping	Tripping time
UL1077	K	0.5 to 63 A	$I_1$	$I_2$	$> 1 h$	$10 \cdot I_n$	$> 0.2 s$
			$1.03 \cdot I_n$	$1.25 \cdot I_n$	$< 1 h$ <sup>3)</sup>	$14 \cdot I_n$	$< 0.2 s$
	Z	0.5 to 63 A	$I_1$	$I_2$	$> 1 h$	$2 \cdot I_n$	$> 0.2 s$
			$1.03 \cdot I_n$	$1.25 \cdot I_n$	$< 1 h$ <sup>3)</sup>	$3 \cdot I_n$	$< 0.2 s$

### K characteristic

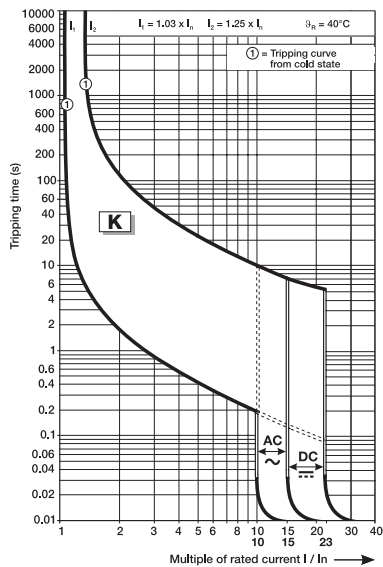

### Z characteristic

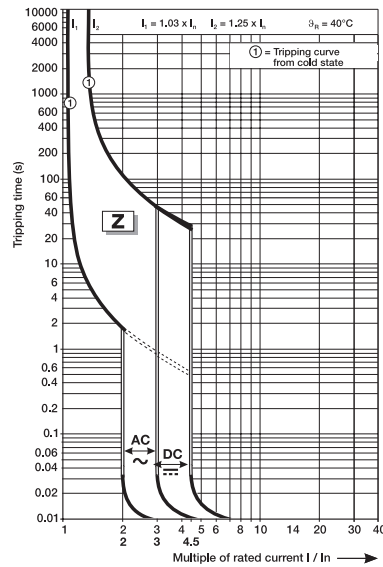

# Miniature Circuit Breaker S200MUC Temperature Derating

## Deviating ambient temperature and adjacent devices

For installation of supplementary protectors at temperatures that are different from the reference temperature and installations of several supplementary protectors directly side by side, derating factors apply to be considered.

### Ambient temperature

The rated value of the current of a supplementary protectors with K characteristic refers to a reference ambient temperature of 20 °C.

The following table shows derating factors for ambient temperature from –40 to 70 °C for the characteristic K.

Rated current I <sub>n</sub> A	Maximum operating current at ambient temperature T A											
	-40°C	-30°C	-20°C	-10°C	0°C	10°C	20°C	30°C	40°C	50°C	60°C	70°C
0.5	0.66	0.64	0.61	0.59	0.56	0.53	0.50	0.47	0.43	0.40	0.35	0.31
1.0	1.32	1.27	1.22	1.17	1.12	1.06	1.00	0.94	0.87	0.79	0.71	0.61
1.6	2.12	2.04	1.96	1.88	1.79	1.70	1.60	1.50	1.39	1.26	1.13	0.98
2.0	2.65	2.55	2.45	2.35	2.24	2.12	2.00	1.87	1.73	1.58	1.41	1.22
3.0	4.0	3.8	3.7	3.5	3.4	3.2	3.0	2.8	2.6	2.4	2.1	1.8
4.0	5.3	5.1	4.9	4.7	4.5	4.2	4.0	3.7	3.5	3.2	2.8	2.4
6.0	7.9	7.6	7.3	7.0	6.7	6.4	6.0	5.6	5.2	4.7	4.2	3.7
8.0	10.8	10.2	9.8	9.4	8.9	8.5	8.0	7.5	6.9	6.3	5.7	4.9
10.0	13.2	12.7	12.2	11.7	11.2	10.6	10.0	9.4	8.7	7.9	7.1	6.1
13.0	17.2	16.6	15.9	15.2	14.5	13.8	13.0	12.2	11.3	10.3	9.2	8.0
16.0	21.2	20.4	19.6	18.8	17.9	17.0	16.0	15.0	13.9	12.6	11.3	9.8
20.0	26.5	25.5	24.5	23.5	22.4	21.2	20.0	18.7	17.3	15.8	14.1	12.2
25.0	33.1	31.9	30.6	29.3	28.0	26.5	25.0	23.4	21.7	19.8	17.7	15.3
32.0	42.3	40.8	39.2	37.5	35.8	33.9	32.0	29.9	27.7	25.3	22.6	19.6
40.0	52.9	51.0	49.0	46.9	44.7	42.4	40.0	37.4	34.6	31.6	28.3	24.5
50.0	66.1	63.7	61.2	58.6	55.9	53.0	50.0	46.8	43.3	39.5	35.4	30.6
63.0	83.3	80.3	77.2	73.9	70.4	66.8	63.0	58.9	54.6	49.8	44.5	38.6

### Influence of adjacent devices

If several miniature circuit breakers are installed directly side by side with high load on all poles, a correction factor has to be applied to the rated current (see table). If distance pieces (spacers) are used, the factor is not to be considered.

No. of adjacent devices	Factor F
1	1
2	0.95
3	0.9
4	0.86
5	0.82
6	0.795
7	0.78
8	0.77
9	0.76
>9	0.76

# Miniature Circuit Breaker S200MUC

## Accessory overview and dimensional drawing

- 
- H:**  
Auxiliary contact  
(S2C-H6RU)
- H-R:**  
Auxiliary contact  
(S2C-H6-...R)
- S/H:**  
Signal contact  
(S2C-S6RU)
- S/H (H):**  
S2C-S/H6R  
used as auxiliary contact
- ST:**  
Shunt trip for SU200M MCB  
(S2C-A...U)
- UR:**  
Undervoltage release  
(S2C-UA)

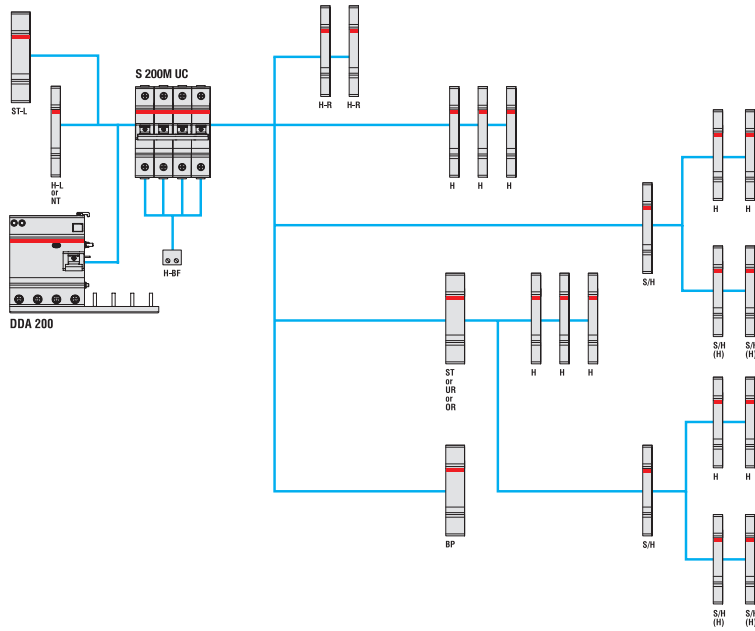

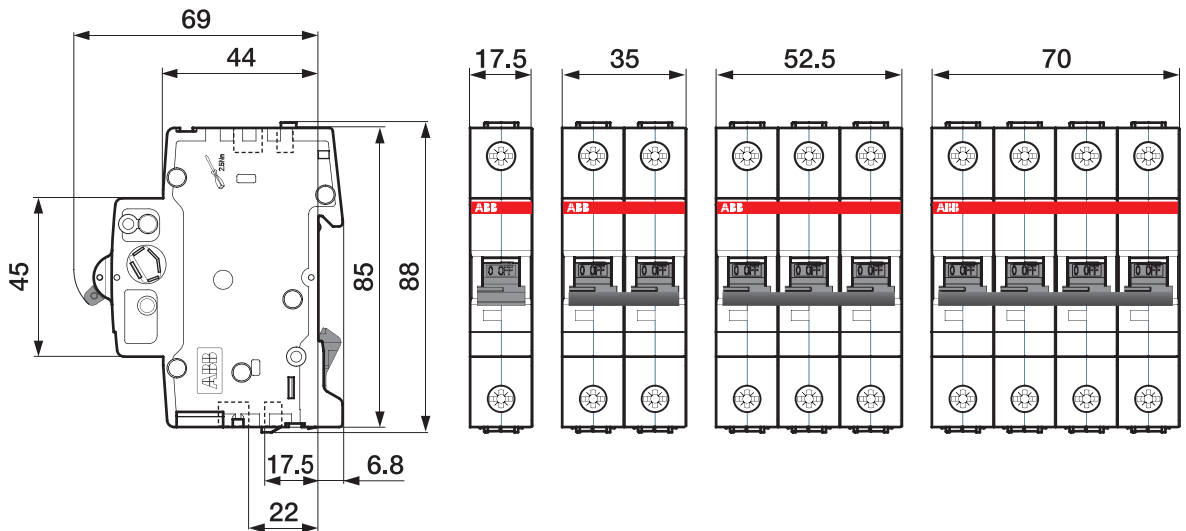

### Dimensional drawings



# Miniature Circuit Breaker S200MUC

Ordering data characteristic K

1 pole	Box Qty	Weight each (kg)	Rated current	Part number
	10	0.125	0.2 A	S201MUC-K0.2
			0.3 A	S201MUC-K0.3
			0.5 A	S201MUC-K0.5
			0.75 A	S201MUC-K0.75
			1.0 A	S201MUC-K1
			1.6 A	S201MUC-K1.6
			2.0 A	S201MUC-K2
			3.0 A	S201MUC-K3
			4.0 A	S201MUC-K4
			5.0 A	S201MUC-K5
			6.0 A	S201MUC-K6
			8.0 A	S201MUC-K8
			10.0 A	S201MUC-K10
			13.0 A	S201MUC-K13
			15.0 A	S201MUC-K15
			16.0 A	S201MUC-K16
			20.0 A	S201MUC-K20
			25.0 A	S201MUC-K25
			30.0 A	S201MUC-K30
			32.0 A	S201MUC-K32
			35.0 A	S201MUC-K35
40.0 A	S201MUC-K40			
50.0 A	S201MUC-K50			
60.0 A	S201MUC-K60			
63.0 A	S201MUC-K63			

2 pole	Box Qty	Weight each (kg)	Rated current	Part number
	5	0.250	0.2 A	S202MUC-K0.2
			0.3 A	S202MUC-K0.3
			0.5 A	S202MUC-K0.5
			0.75 A	S202MUC-K0.75
			1.0 A	S202MUC-K1
			1.6 A	S202MUC-K1.6
			2.0 A	S202MUC-K2
			3.0 A	S202MUC-K3
			4.0 A	S202MUC-K4
			5.0 A	S202MUC-K5
			6.0 A	S202MUC-K6
			8.0 A	S202MUC-K8
			10.0 A	S202MUC-K10
			13.0 A	S202MUC-K13
			15.0 A	S202MUC-K15
			16.0 A	S202MUC-K16
			20.0 A	S202MUC-K20
			25.0 A	S202MUC-K25
			30.0 A	S202MUC-K30
			32.0 A	S202MUC-K32
			35.0 A	S202MUC-K35
40.0 A	S202MUC-K40			
50.0 A	S202MUC-K50			
60.0 A	S202MUC-K60			
63.0 A	S202MUC-K63			

3 pole	Box Qty	Weight each (kg)	Rated current	Part number
	1	0.375	0.2 A	S203MUC-K0.2
			0.3 A	S203MUC-K0.3
			0.5 A	S203MUC-K0.5
			0.75 A	S203MUC-K0.75
			1.0 A	S203MUC-K1
			1.6 A	S203MUC-K1.6
			2.0 A	S203MUC-K2
			3.0 A	S203MUC-K3
			4.0 A	S203MUC-K4
			5.0 A	S203MUC-K5
			6.0 A	S203MUC-K6
			8.0 A	S203MUC-K8
			10.0 A	S203MUC-K10
			13.0 A	S203MUC-K13
			15.0 A	S203MUC-K15
			16.0 A	S203MUC-K16
			20.0 A	S203MUC-K20
			25.0 A	S203MUC-K25
			30.0 A	S203MUC-K30
			32.0 A	S203MUC-K32
			35.0 A	S203MUC-K35
40.0 A	S203MUC-K40			
50.0 A	S203MUC-K50			
60.0 A	S203MUC-K60			
63.0 A	S203MUC-K63			

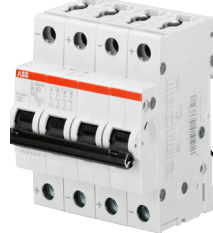
4 pole	Box Qty	Weight each (kg)	Rated current	Part number
	1	0.500	0.2 A	S204MUC-K0.2
			0.3 A	S204MUC-K0.3
			0.5 A	S204MUC-K0.5
			0.75 A	S204MUC-K0.75
			1.0 A	S204MUC-K1
			1.6 A	S204MUC-K1.6
			2.0 A	S204MUC-K2
			3.0 A	S204MUC-K3
			4.0 A	S204MUC-K4
			5.0 A	S204MUC-K5
			6.0 A	S204MUC-K6
			8.0 A	S204MUC-K8
			10.0 A	S204MUC-K10
			13.0 A	S204MUC-K13
			15.0 A	S204MUC-K15
			16.0 A	S204MUC-K16
			20.0 A	S204MUC-K20
			25.0 A	S204MUC-K25
			30.0 A	S204MUC-K30
			32.0 A	S204MUC-K32
			35.0 A	S204MUC-K35
40.0 A	S204MUC-K40			
50.0 A	S204MUC-K50			
60.0 A	S204MUC-K60			
63.0 A	S204MUC-K63			

# Miniature Circuit Breaker S200MUC

Ordering data characteristic Z

1 pole	Box Qty	Weight each (kg)	Rated current	Part number
	10	0.125	0.2 A	S201MUC-Z0.2
			0.3 A	S201MUC-Z0.3
			0.5 A	S201MUC-Z0.5
			0.75 A	S201MUC-Z0.75
			1.0 A	S201MUC-Z1
			1.6 A	S201MUC-Z1.6
			2.0 A	S201MUC-Z2
			3.0 A	S201MUC-Z3
			4.0 A	S201MUC-Z4
			5.0 A	S201MUC-Z5
			6.0 A	S201MUC-Z6
			8.0 A	S201MUC-Z8
			10.0 A	S201MUC-Z10
			13.0 A	S201MUC-Z13
			15.0 A	S201MUC-Z15
			16.0 A	S201MUC-Z16
			20.0 A	S201MUC-Z20
			25.0 A	S201MUC-Z25
			30.0 A	S201MUC-Z30
			32.0 A	S201MUC-Z32
			35.0 A	S201MUC-Z35
40.0 A	S201MUC-Z40			
50.0 A	S201MUC-Z50			
60.0 A	S201MUC-Z60			
63.0 A	S201MUC-Z63			

2 pole	Box Qty	Weight each (kg)	Rated current	Part number
	5	0.250	0.2 A	S202MUC-Z0.2
			0.3 A	S202MUC-Z0.3
			0.5 A	S202MUC-Z0.5
			0.75 A	S202MUC-Z0.75
			1.0 A	S202MUC-Z1
			1.6 A	S202MUC-Z1.6
			2.0 A	S202MUC-Z2
			3.0 A	S202MUC-Z3
			4.0 A	S202MUC-Z4
			5.0 A	S202MUC-Z5
			6.0 A	S202MUC-Z6
			8.0 A	S202MUC-Z8
			10.0 A	S202MUC-Z10
			13.0 A	S202MUC-Z13
			15.0 A	S202MUC-Z15
			16.0 A	S202MUC-Z16
			20.0 A	S202MUC-Z20
			25.0 A	S202MUC-Z25
			30.0 A	S202MUC-Z30
			32.0 A	S202MUC-Z32
			35.0 A	S202MUC-Z35
40.0 A	S202MUC-Z40			
50.0 A	S202MUC-Z50			
60.0 A	S202MUC-Z60			
63.0 A	S202MUC-Z63			

3 pole	Box Qty	Weight each (kg)	Rated current	Part number
	1	0.375	0.2 A	S203MUC-Z0.2
			0.3 A	S203MUC-Z0.3
			0.5 A	S203MUC-Z0.5
			0.75 A	S203MUC-Z0.75
			1.0 A	S203MUC-Z1
			1.6 A	S203MUC-Z1.6
			2.0 A	S203MUC-Z2
			3.0 A	S203MUC-Z3
			4.0 A	S203MUC-Z4
			5.0 A	S203MUC-Z5
			6.0 A	S203MUC-Z6
			8.0 A	S203MUC-Z8
			10.0 A	S203MUC-Z10
			13.0 A	S203MUC-Z13
			15.0 A	S203MUC-Z15
			16.0 A	S203MUC-Z16
			20.0 A	S203MUC-Z20
			25.0 A	S203MUC-Z25
			30.0 A	S203MUC-Z30
			32.0 A	S203MUC-Z32
			35.0 A	S203MUC-Z35
40.0 A	S203MUC-Z40			
50.0 A	S203MUC-Z50			
60.0 A	S203MUC-Z60			
63.0 A	S203MUC-Z63			

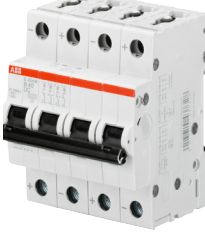
4 pole	Box Qty	Weight each (kg)	Rated current	Part number
	1	0.500	0.2 A	S204MUC-Z0.2
			0.3 A	S204MUC-Z0.3
			0.5 A	S204MUC-Z0.5
			0.75 A	S204MUC-Z0.75
			1.0 A	S204MUC-Z1
			1.6 A	S204MUC-Z1.6
			2.0 A	S204MUC-Z2
			3.0 A	S204MUC-Z3
			4.0 A	S204MUC-Z4
			5.0 A	S204MUC-Z5
			6.0 A	S204MUC-Z6
			8.0 A	S204MUC-Z8
			10.0 A	S204MUC-Z10
			13.0 A	S204MUC-Z13
			15.0 A	S204MUC-Z15
			16.0 A	S204MUC-Z16
			20.0 A	S204MUC-Z20
			25.0 A	S204MUC-Z25
			30.0 A	S204MUC-Z30
			32.0 A	S204MUC-Z32
			35.0 A	S204MUC-Z35
40.0 A	S204MUC-Z40			
50.0 A	S204MUC-Z50			
60.0 A	S204MUC-Z60			
63.0 A	S204MUC-Z63			

# Miniature Circuit Breaker S200MUC

## Use of MCB in DC circuits

### Use of S200MUC in direct current circuits (250 / 500 Vdc)

S200MUC miniature circuit breakers can be used in the 1 pole version at 250 VDC, and in the 2-pole or 4-pole version with series connection of two poles up to 500 VDC. S200MUC differs from the standard S200 type. It is equipped with permanent magnets that assist in the forced extinguishing of the arc.

If voltages to ground exceeding 250 VDC occur, 2-pole S200MUC should be used for one-pole disconnection and four-pole S200MUC for all-pole disconnection

### For DC incoming supply from top / above

S200MUC MCBs have permanent magnets in the area of arc chutes. Therefore, it is necessary to take into account the polarity during the installation process. In the case of a short circuit, the magnetic field of the permanent magnets corresponds with the electromagnetic field of the short-circuit current, therefore, safely leading the short circuit into the arc chute. Incorrect polarities may cause damage to the MCB. As a result for top-fed devices, terminal 1 must be connected to (-) and terminal 3 to (+).

### Example of permissible voltages between the conductors depending on the number of poles and circuit layout

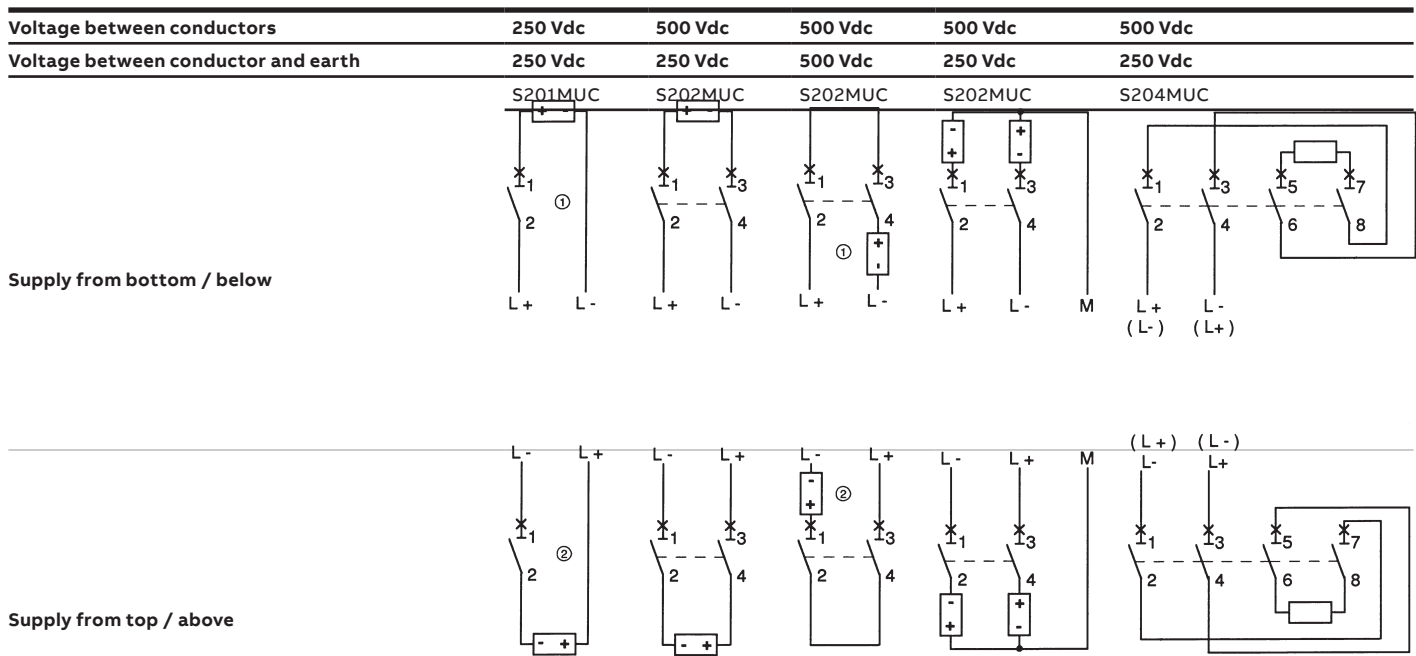

(1) In the circuit diagram, the negative pole is earthed

(2) In the circuit diagram, the positive pole is earthed



# Miniature Circuit Breaker S200MUC

## Use of MCB in DC circuits

Example of permissible voltages between the conductors depending on the number of poles and circuit layout for S200MUC

Voltage between conductors	500 Vdc All-pole disconnection	500 Vdc 1-pole disconnection	500 Vdc All-pole disconnection
Voltage between conductor and earth	250 Vdc Symmetrically grounded	250 Vdc Unsymmetrically grounded	250 Vdc Unsymmetrically grounded
	S202MUC	S202MUC	S204MUC

Supply from bottom / Below

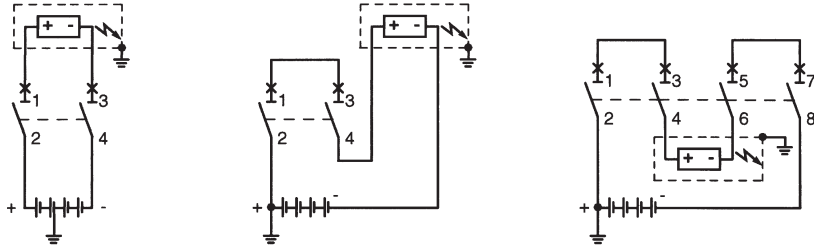

- (1) In the circuit diagram, the negative pole is earthed
- (2) In the circuit diagram, the positive pole is earthed