

Trip circuit supervision relay



Features

- Continuous monitoring of circuit-breaker trip circuits and other essential control circuits
- Preset operate time preventing unwanted alarm signals at circuit-breaker operation
- Indication of relay operation with LED indicator on the front panel and output relay
- Detects bad contact, contact welding and auxiliary voltage failures in the supervised circuit
- Mechanical design according to the COMBIFLEX assembly system
- Member of the SPACOM product family and ABB's Substation Automation system

Application

The trip circuit supervision relays SPER 1C1 and SPER 1C2 are used for supervising important control circuits such as circuit-breaker and disconnecter control circuits and signalling circuits in power electrical installations. Generally one supervision relay is needed per circuit to be supervised. If several branches of a circuit are to be supervised, the required number of relays can be connected to the same control circuit.

The supervision relays SPER 1C1 and SPER 1C2 are mechanically designed to suit the COMBIFLEX system. The both types differ from each other as to the supply voltage range and the minimum supervision circuit voltage. If a rail-mounted or surface-mounted, not COMBIFLEX, supervision relay is required, please refer to the type SPER 1B1 C4.

Design

The supervision relay detects circuit interruption, high transition resistance caused by bad galvanic connection, high contact transition resistance, control contact welding, disappearing control voltage and disappearing relay supply voltage.

The supervision relay contains a constant current generator, an opto-isolator, a triggering circuit, a time circuit, two LED indicators and an output relay.

The constant current generator forces a small current to flow through the supervised circuit. If the current, because of a fault in the circuit, cannot be fed through the circuit, the relay operates. When the triggering circuit detects a fault in the supervised circuit the relay generates an visual fault indication and an output relay function after a preset time delay of three seconds. The output relay is normally energized and as the relay operates the output relay drops. The output relay also drops if the auxiliary supply of the relay disappears.

The supervision circuit is optically isolated from the rest of the relay's circuitry. Thus the auxiliary supply for the relay can be taken from a separate source, though it is normally taken from the supervised circuit.

Auxiliary supply voltage

To operate the supervision relay needs a continuous auxiliary voltage. The auxiliary voltage range of the relay SPER 1C1 is 40...265 V dc and that of the relay SPER 1C2 is 20...60 V dc. Normally, the auxiliary supply voltage and the voltage of the supervised circuit are one and the same. The circuits are, however, galvanically separated in the relay. Separate voltage sources can be used for supply of the relay and the supervised circuit.

Under certain conditions, the supervision relay can also be supplied from the supervised circuit. Components in the supervised circuit, for instance trip coils, must not be affected by the current drawn by the supervision relay, i.e. ~7 mA for SPER 1C1 and ~16 mA for SPER 1C2 and the voltage of the supervised circuit must not fall below 40 V dc for SPER 1C1 and 20 V for SPER 1C2.

Technical data

Table 1: Monitored circuit

Voltage of monitored circuit	SPER 1C1	40...265 V dc
	SPER 1C2	20...60 V dc
Measuring current, typ.	SPER 1C1	1.5 mA
	SPER 1C2	5 mA
Minimum residual voltage over the monitored circuit	SPER 1C1, terminals 11-21	>40 V dc
	SPER 1C2 terminals 11-21	>20 V dc
Typical resistance at (for SPER 1C1, SPE-ZR3)	48 V dc	1.2 kΩ/4W
	60 V dc	5.6 kΩ/4W
	110 V dc	22 kΩ/4W
	220 V dc	28.8 kΩ/4W or 33 kΩ/4W
Typical resistance at (for SPER 1C2, SPE-ZR4)	30 V dc	680 Ω/4W
	48 V dc	2.2 kΩ/4W

Table 2: Time circuit

Operate delay, typ.	3 s
Reset time, typ.	1 s

Table 3: Auxiliary supply voltage and current

Rated voltage U_n	SPER 1C1	48/60/110/220 V dc
	SPER 1C2	24/48 V dc
Operation voltage	SPER 1C1	40...265 V dc
	SPER 1C2	20...60 V dc
Current drain, typ.	SPER 1C1	7 mA
	SPER 1C2	16 mA

Table 4: Output relay

Terminals	15-16-17/25-26-27
Rated voltage	250 V ac/dc
Continuous carry ($L/R \leq 40$ ms) at 220/110/48 V dc	0.15/0.25/1 A

Table 5: Tests and standards

Test voltages	Dielectric test voltage (IEC 255-5)	2 kV, 50 Hz, 1 min
	Impulse test voltage (IEC 255-5)	5 kV, 1.2/50 μ s, 0.5 J
Disturbance tests	HF disturbance test (IEC 255-5)	2.5 kV, 1 MHz
	Fast transients (IEC 801-4)	2 kV, 5/50 ns, 1 min.
	Spark interference (SS 436-15-03)	4...8 kV
Environmental conditions	Service temperature range	-10...+55°C
	Damp heat test (IEC 68-2-30)	93...95%, +55°C, 6 x 24 h
	Transport and storage temperature range	-40...+70°C
Weight	SPER 1C1 and SPER 1C2	~0.2 kg

Block diagram

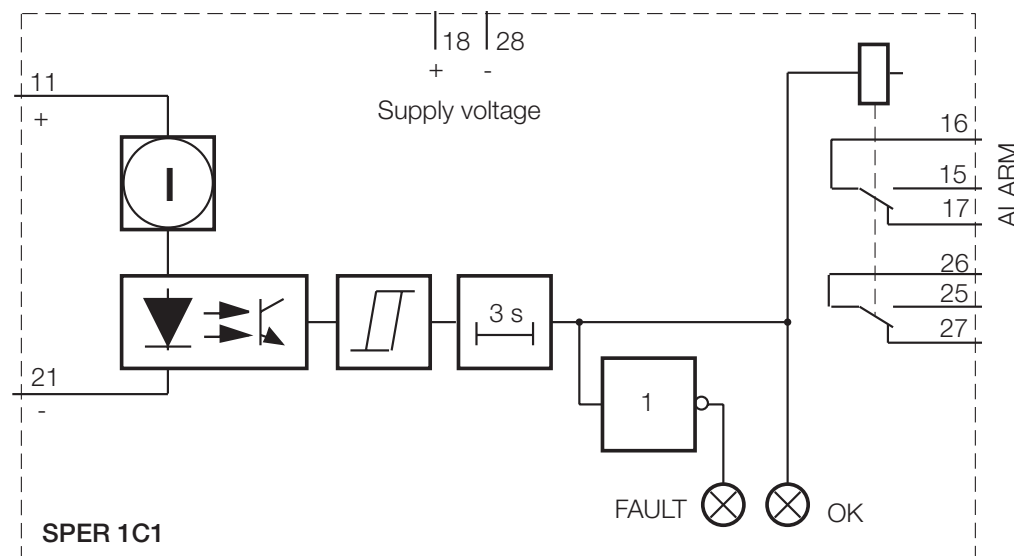

Fig. 1 Block diagram

Ordering**When ordering, please specify:**

Ordering information	Ordering example
1. Type designation and quantity	SPER 1C1, 5 pieces
2. Order number	RS 485 002-AA
3. Auxiliary voltage	$U_{aux}=110$ V dc

Order numbers

Supervision relay, SPER 1C1, $U_{aux} = 40\dots265$ V dc	RS 485 002-AA
Supervision relay, SPER 1C2, $U_{aux} = 20\dots60$ V	RS 485 003-AA

References**Additional information**

User's Manual and Technical Description "SPER 1B1 C4, SPER 1C1, SPER 1C2"	1MRS 750231-MUM EN
--	--------------------

**ABB Oy**

P.O. Box 699
FIN-65101 Vaasa, Finland
Tel +358 10 224 000
Fax +358 10 224 1094
www.abb.com/substationautomation