

Product Guide

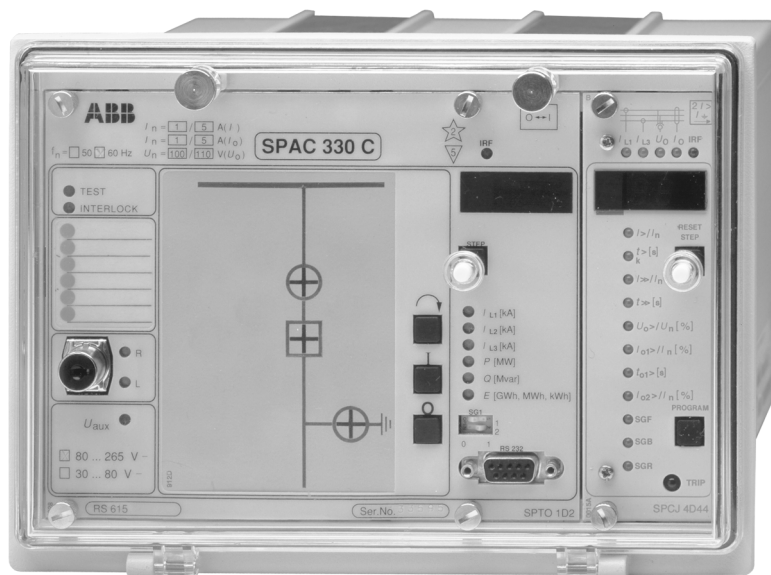

Features

- Complete feeder terminal with a two-phase two-stage overcurrent unit and a sensitive, two-stage directional earth-fault unit
- Selectable definite time or inverse definite minimum time (IDMT) operation characteristic for the low-set stage of the overcurrent unit
- Selectable instantaneous or definite time operation characteristic for the high-set stage of the overcurrent unit
- Directional low-set earth-fault stage with definite time operation characteristic
- Directional or non-directional high-set earth-fault stage with preset instantaneous operation time
- User-configurable feeder level interlocking system for preventing unpermitted switching operations
- Local and remote status indication of three devices
- Complete control module for local/remote control of one device
- Large library of pre-designed mimic diagrams for presenting the circuit-breaker/disconnector configuration selected
- Six user-configurable binary inputs with local and remote indication
- Measurement and indication of phase current, energy and active and reactive power
- Serial interface for connecting the feeder terminal to substation level and network control level systems
- Continuous self-supervision for maximum system reliability and availability
- Member of the SPACOM product family and ABB's Distribution Automation system

Application

The feeder terminal type SPAC 330 C is designed to be used as a cubicle-oriented protection and remote control unit. In addition to protection, control and measurement functions, the feeder terminals are provided with the data communication facilities needed for the control of a feeder cubicle. Connection to higher-level substation control equipment is carried out via a fibre-optical serial bus.

The feeder terminal SPAC 330 C is part of ABB's Distribution Automation concept, the complete ABB solution for the control and management of electric power systems.

If sensitive earth-fault protection is required, the feeder terminal type SPAC 331 C is recommended.

Design

The feeder terminal includes a relay module type SPCJ 4D44 for the protection functions and a control module type SPTO 1D2 for the control, measurement and supervision functions.

Protection relay module

Overcurrent unit

The combined two-phase overcurrent and directional earth-fault relay module SPCJ 4D44 continuously measures two phase currents and the neutral current of the feeder to be protected.

If the phase current exceeds the set start current of the low-set stage $I_{>}$, the overcurrent unit starts and, after the preset start time, it delivers a start signal. When the set operate time, at definite time operation, or the calculated operate time, at inverse time operation, has elapsed, the overcurrent unit operates. In the same way, the high-set stage $I_{>>}$ of the overcurrent unit starts when the set start current is exceeded and delivers a start signal after the preset (~40 ms) start time. When the set operate time has elapsed, the overcurrent unit operates.

The low-set stage of the overcurrent unit may be given a definite time or inverse definite minimum time (IDMT) characteristic. The IDMT characteristic includes six time/current curve sets. Four of the curve sets comply with the BS 142 and IEC 255 and are named “Normal inverse”, “Very inverse”, “Extremely inverse” and “Long-time inverse”. The two additional inverse time curve sets comply with ABB standards and are called “RI” and “RXIDG”.

Earth-fault unit

When the neutral current exceeds the set start current of the low-set stage $I_{01>}$, the residual voltage U_0 exceeds the selected start voltage and the phase angle between the residual voltage and the neutral current is within the range $\varphi_0 \pm \Delta \varphi$, where φ_0 = basic angle and $\Delta \varphi = 80^\circ$ the directional low-set stage $I_{01>}$ starts and its operate time $t_{01>}$ starts running. When the set operate time has elapsed, the low-set stage operates.

The high-set stage I_{02} of the earth-fault unit operates in the same way as the low-set stage, but with the preset operate time <100 ms.

The high-set stage I_{02} of the earth-fault unit can be given a directional or non-directional operating characteristic.

The energizing inputs of the earth-fault unit are provided with low-pass filters, which filter out clean measuring signals from severely distorted energizing quantities.

Control module

Status functions

The control module SPTO 1D2 is used for reading status information from the circuit breaker, the CB truck and the disconnectors of the switchgear cubicle to be controlled. The module indicates the status locally by means of LED indicators and transfers the status information to the substation control level via the fibre-optic SPA bus. The status of maximum three switching devices can be indicated.

Control functions

The control module is also used for controlling one switching object e.g. a circuit breaker, locally by means of push buttons on the front panel and remotely via open or close commands transmitted over the fibre-optic bus. Normally, the double-pole control principle is used for the circuit breaker control.

Additional binary inputs

In addition to status information, the control module is able to read other binary information, indicate it locally and transfer it to the substation control level. Six external binary signals can be wired to the feeder terminal.

Interlocking

The control module includes a cubicle-oriented interlocking system which is freely programmable by the user. By writing an interlocking program the user defines under which conditions the object can be closed or opened. When an open or close command is given, the interlocking program decides whether the control command can be executed or has to be cancelled.

The trip signals generated by the protection relay module are not affected by the interlocking system.

Conditional direct output control

Normally, the circuit breaker control outputs are controlled by means of commands initiated by the operator and transmitted via the fibre-optic bus. However, the circuit breaker can also be automatically controlled by the logical direct output control program. This program reads the status of the status input

Design (cont'd)

channels, the binary input channels and the R/L key switch and carries out the programmed circuit breaker control functions and possible signalling functions, if the defined conditions are fulfilled.

Measurement functions

The control module SPTO 1D2 and the combined overcurrent and earth-fault relay module SPCJ 4D44 both measure analog signals.

The combined overcurrent and earth-fault relay module measures three phase currents and neutral current. The module displays the current values locally and transmits the information to the remote control system via the SPA bus.

The control module SPTO 1D2 measures five analog signals: three phase currents, active and reactive power. The transformation ratio of the primary current transformers can be written to the control module to enable it to display the measured phase currents as primary values.

Active and reactive power is measured via two mA inputs using external measuring transducers. The mA signals are scaled to actual MW and Mvar values. The data is displayed locally and can be transmitted to the remote control system.

Active energy is measured in two ways: either by calculating the value from the power values measured or by using one of the inputs, i.e. input 7, as an energy measuring input. In the latter case an external energy meter with pulse output will be needed. In both cases the measured energy value is displayed locally and, when required, transmitted to the remote control system.

Self-supervision

The feeder terminal incorporates a sophisticated self-supervision system with auto-diagnosis, which increases the availability of the feeder terminal and the reliability of the system. The self-supervision system continuously monitors the hardware and the software of the feeder terminal. The system also super-

vises the operation of the auxiliary supply module and the voltages generated by the module.

When the self-supervision system detects a permanent internal relay fault, the IRF indicator on the feeder terminal is lit. At the same time the output relay of the self-supervision system operates and a fault message is transmitted to the higher-level system over the serial bus. Further, in most fault situations, a fault code is shown in one of the displays. The fault code indicates the type of the fault that has been detected.

Data communication

The feeder terminal includes two serial communication ports, one on the front panel and the other on the rear panel.

The 9-pin RS 232 connection on the front panel is used for configuring the feeder terminal and determining the configuration of switching devices, for loading the feeder-oriented interlocking program and other data from a terminal or a PC.

The 9-pin RS 485 connection on the rear panel connects the feeder terminal to the SPA bus by means of a bus connection module type SPA-ZC 17 or SPA-ZC 21. The bus connection module type SPA-ZC 21 is powered from the host terminal, whereas the bus connection module SPA-ZC 17 is provided with a built-in power unit, which can be fed from an external secured power source. The feeder terminal communicates with higher-level data acquisition and control systems over the SPA bus.

Auxiliary supply voltage

The auxiliary supply of the relay is obtained from an internal plug-in type power supply module. Two auxiliary power module versions are available: type SPGU 240A1 for the supply voltage range 80...265 V ac/dc and type SPGU 48B2 for the supply voltage range 18...80 V dc. The power supply module forms the internal voltages required by the protection relay and the I/O module.

Technical data

Table 1: Energizing inputs, overcurrent unit

Terminals		X0/1-3, 7-9	X0/1-2, 7-8
Rated current I_n		1 A	5 A
Thermal withstand capability	continuously	4 A	20 A
	for 1 s	100 A	500 A
Dynamic current withstand capability	Half-wave value	250 A	1250 A
Input impedance		<100 m Ω	<20 m Ω
Rated frequency f_n , according to order		50 Hz or 60 Hz	

Table 2: Energizing inputs, earth-fault unit

Terminals		X0/25-27	X0/25-26
Rated current I_n		1 A	5 A
Thermal withstand capability	continuously	4 A	20 A
	for 1 s	100 A	500 A
Dynamic current withstand capability	Half-wave value	250 A	1250 A
Input impedance		<100 m Ω	<20 m Ω
Rated frequency f_n , according to order		50 Hz or 60 Hz	

Table 3: External inputs

mA inputs	Terminals	Active power	X3/1-2
		Reactive power	X3/3-4
	Input current range		-20 mA...0...20 mA
Binary inputs	Terminals	CHANNEL 1...3, four-pole inputs	X2/8-14, 9-14, 10-14, 11-14, 12-14 and 13-14
		CHANNEL 4...9, single-contact inputs	X2/1-5, 2-5, 3-5, 4-5, 6-7 and X1/10-11
	Control input voltage range	input module SPTR 3B12	80...265 V dc
		input module SPTR 3B13	30...80 V dc
	Current consumption at activation		2...20 mA
Energy pulse counter input, CHANNEL 7	Terminals		X2/4-5
	Maximum control frequency		25 Hz
	Input voltage range	input module SPTR 3B12	80...265 V dc
		input module SPTR 3B13	30...80 V dc
	Current consumption at activation		2...20 mA
Blocking input, CHANNEL 8	Terminals		X2/6-7
	Input voltage range	input module SPTR 3B12	80...265 V dc
		input module SPTR 3B13	30...80 V dc
	Current consumption at activation		2...20 mA

Technical data (cont'd)

Table 4: Output contact ratings

Type of contact		Tripping	Signalling
Terminals		X0/65-66, 85-86	X1/1-2-3, 4-5, 6-7, 8-9
Rated voltage		250 V ac/dc	
Thermal withstand capability	Carry continuously	5 A	5 A
	Make and carry for 0.5 s	30 A	10 A
	Make and carry for 3 s	15 A	8 A
Breaking capacity for dc, when the control/signalling circuit time constant $L/R \leq 40$ ms, at the control voltages	220 V dc	1 A	0.15 A
	110 V dc	3 A	0.25 A
	48 V dc	5 A	1 A
Control output operating mode	When operated by the control module	Pulse shaping	–
	Control pulse length	0.1...100 s	–

Table 5: Data communication

Rear panel	Connection		RS 485, 9-pin, female
	Bus connection module for rear connection	for plastic core cables	SPA-ZC 21C BB
		for glass fibre cables	SPA-ZC 21C MM
	Bus connection module for separate mounting	for plastic core cables	SPA-ZC 17C BB
for glass fibre cables		SPA-ZC 17C MM	
Front panel	Connection		RS 232, 9-pin, female
	Data code		ASCII
	Selectable data transfer rates		4800 or 9600 Bd

Table 6: Auxiliary supply modules

Type of module	Operative range	SPGU 240A1	80...265 V ac/dc
		SPGU 48B2	18...80 V dc
	Power consumption	under quiescent conditions	~10 W
		under operating conditions	~15 W

Table 7: Relay module SPCJ 4D44, overcurrent unit

Features		Low-set stage I>	High-set stage I>>
Start current	at definite time	$0.5...5.0 \times I_n$	$0.5...40.0 \times I_n$ or ∞ , infinite
	at inverse time	$0.5...2.5 \times I_n$	–
Start time, typically		60 ms	40 ms
Operate time at definite time characteristic		0.05...300 s	0.04...300 s
Time/current characteristic at IDMT operation characteristic		Extremely inverse Very inverse Normal inverse Long-time inverse RI type inverse RXIDG type inverse	–
Time multiplier k		0.05...1.00	–
Reset time, typically		50 ms	50 ms
Drop-off/pick-up ratio, typically		0.96	–
Operate time accuracy at definite time operation characteristic		$\pm 2\%$ of set value or ± 25 ms	
Operate time accuracy class E at inverse time operation characteristic		5	–
Operation accuracy		$\pm 3\%$ of set value	

Technical data (cont'd)

Table 8: Relay module SPCJ 4D44, earth-fault unit

Features		Low-set stage $I_{01}>$	High-set stage $I_{02}>>$
Basic angle φ_b		0°, -30°, -60° or -90°	
Operation sector $\Delta\varphi$		$\pm 80^\circ$, $\pm 88^\circ$	
Residual voltage stage $U_{0>}$	Start voltage $U_{0>}$	2.0...80.0% of U_n	
Operation direction		Forward or reverse	
Operation mode		Directional	Directional or non-directional
Start current		1.0...25% of I_n	2.0...150% of I_n or ∞ , infinite
Start time, typically		100 ms	–
Operate time		0.1...300 ms	100 ms or 750 ms
Reset time, typically		80 ms	100 ms
Internal reset time of intermittent operation		–	500 ms
Drop-off/pick-up ratio, typically		0.96	
Operate time accuracy		$\pm 2\%$ of set value or ± 25 ms	
Operation accuracy		$\pm 3\%$ of set value + $0.0005 \times I_n$	$\pm 3\%$ of set value or ± 25 ms

Table 9: Control module SPTO 1D2

Control functions	status indication for maximum three objects (e.g. circuit breaker, CB truck, disconnectors, earth switch) user-specific configuration remote or local control (open and close) for one object user-configurable feeder-related interlocking scheme
Measurement functions	phase currents, measuring range $0...2.5 \times I_n$ phase current measuring accuracy better than $\pm 1\%$ of I_n active and reactive power measurement via mA inputs, external measuring transducers are needed mA measuring input current range -20 mA...0...20 mA power measuring accuracy better than $\pm 1\%$ of maximum value of measuring range energy measurement via pulse counter input or by calculating the measured power local and remote reading of measured data as scaled values
Supervision functions	energizing current input supervision trip circuit supervision internal self-supervision

Technical data (cont'd)

Table 10: Tests and standards

Test voltages	Dielectric test voltage (IEC 60255-5)		2 kV, 50 Hz, 1 min
	Impulse test voltage (IEC 60255-5)		5 kV, 1.2/50 μ s, 0.5 J
	Insulation resistance (IEC 60255-5)		>100 M Ω , 500 V dc
Disturbance tests	HF disturbance test (IEC 60255-22-1)	Common mode	2.5 kV, 1 MHz
		Differential mode	1.0 kV, 1 MHz
	Fast transients (IEC 60255-22-4 and IEC 61000-4-4)	Power supply inputs	4 kV, 5/50 ns
		Other inputs	2 kV, 5/50 ns
	Electrostatic discharge test (IEC 60255-22-2 and IEC 61000-4-2)	Air discharge	8 kV
Contact discharge		6 kV	
Environmental conditions	Service temperature range		-10...+55°C
	Transport and storage temperature range (IEC 60068-2-8)		-40...+70°C
	Long-term damp heat withstand (IEC 60068-2-3)		<95%, +40°C, 56 d/a
	Damp heat test (IEC 60068-2-30)		93...95%, +55°C, 6 cycles
	Degree of protection by enclosure of panel-mounted relay		IP 54
	Weight of fully equipped relay		~5.0 kg

Block diagram

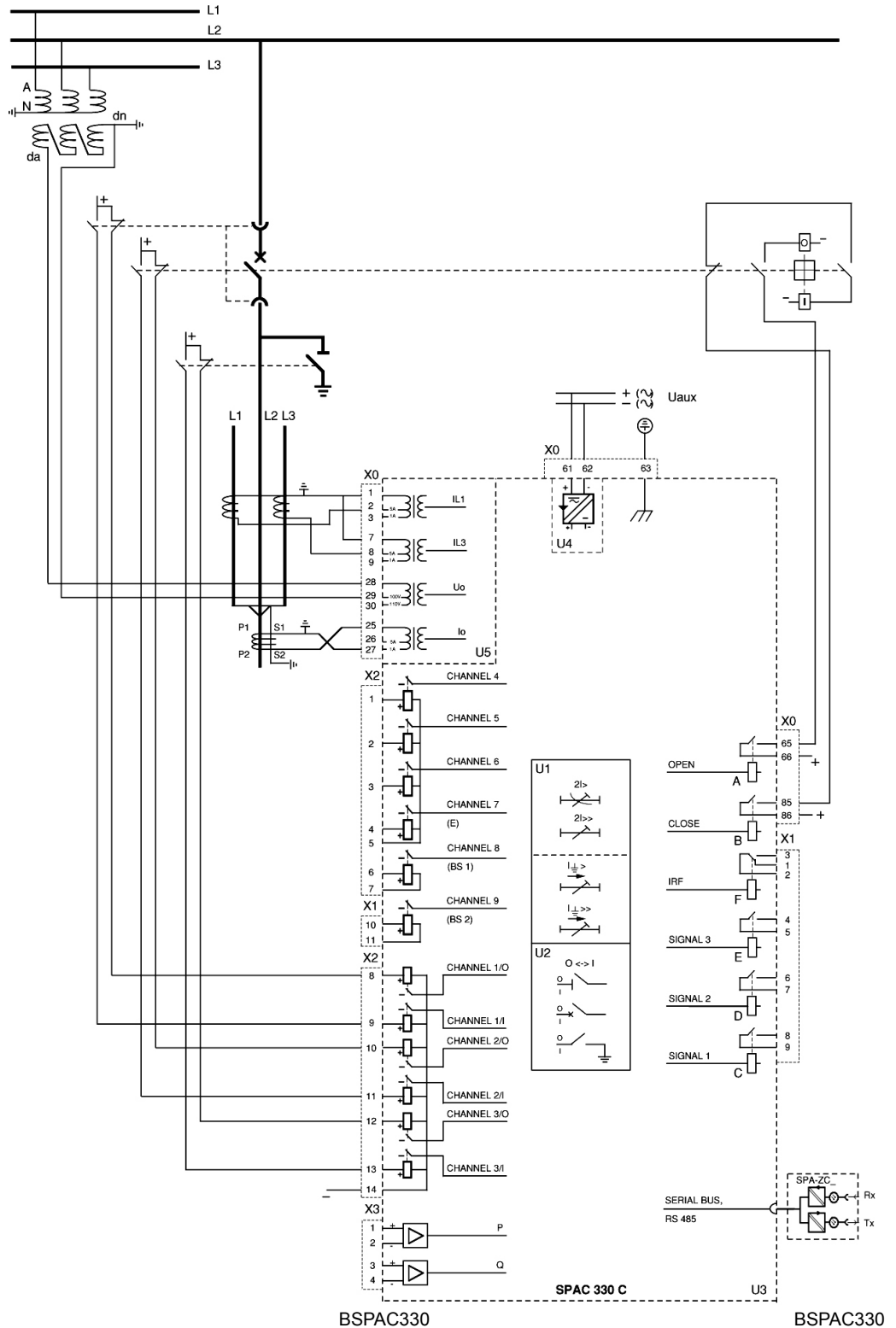

Fig. 1 Block diagram and sample connection diagram

Mounting and dimensions

Flush mounting

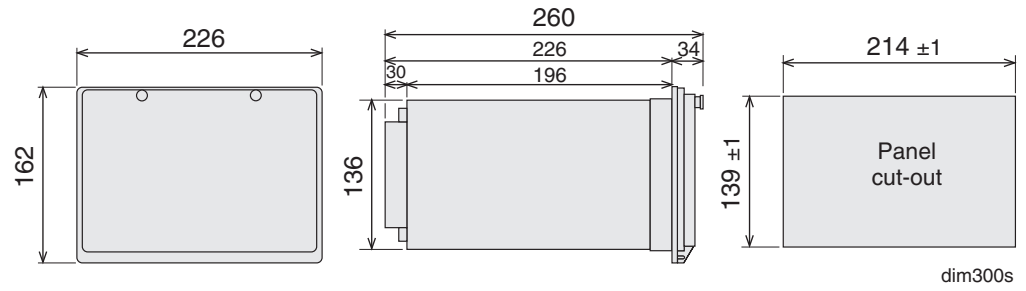

Fig. 2 Flush-mounting relay case (dimensions in mm)

Semi-flush mounting

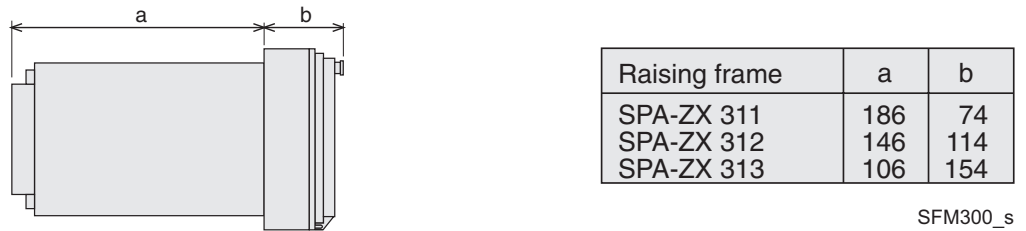

Fig. 3 Semi-flush mounting relay case (dimensions in mm)

Mounting in 19 inch cabinets and frames

An ancillary mounting plate, height 4U (~177 mm), is recommended to be used when the feeder terminals are to be mounted in 19 inch frames or cabinets. The ancillary mounting plate type SPA-ZX 304 accommodates two size 300 feeder terminals and type SPA-ZX 305 one size 300 feeder terminal.

Projecting mounting

When projecting mounting is preferred, a relay case type SPA-ZX 316 is used. The relay case for projecting mounting is provided with front connectors.

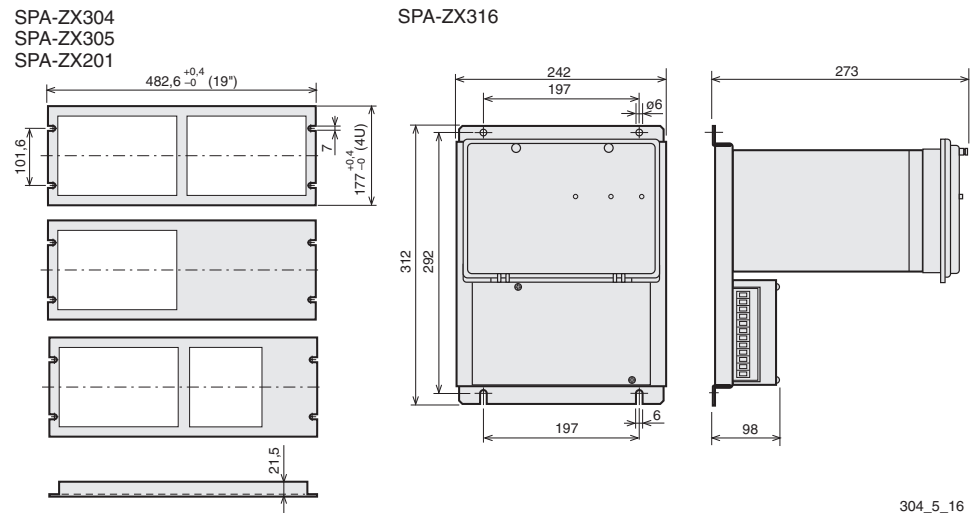

Fig. 4 Mounting cabinets and frames as well as projecting mounting (dimensions in mm)

Ordering**When ordering, please specify:**

Ordering information	Ordering example
1. Type designation and quantity	SPAC 330 C, 5 pieces
2. Order number	RS 615 006-AB
3. Rated values	$I_n=5$ A, $f_n=50$ Hz
4. Auxiliary voltage	$U_{aux}=110$ V dc
5. Accessories	-
6. Type of configuration plate	-
7. Special requirements	-

Order numbers

Feeder terminal SPAC 330 C without test adapter	RS 615 006-AB, CB, DB, FB
Feeder terminal SPAC 330 C including test adapter RTXP 18	RS 615 206-AB, CB, DB, FB
The last two letters of the order number indicate the rated frequency f_n and the auxiliary voltage U_{aux} of the relay as follows:	AB equals $f_n = 50$ Hz and $U_{aux} = 80\dots265$ V ac/dc
	CB equals $f_n = 50$ Hz and $U_{aux} = 18\dots80$ V dc
	DB equals $f_n = 60$ Hz and $U_{aux} = 80\dots265$ V ac/dc
	FB equals $f_n = 60$ Hz and $U_{aux} = 18\dots80$ V dc

References**Additional information**

Manual "Feeder terminal SPAC 330 C, SPAC 331 C"	1MRS752403-MUM EN
---	-------------------



ABB Oy
Distribution Automation
P.O. Box 699
FI-65101 Vaasa, FINLAND
Tel +358 10 22 11
Fax +358 10 224 1094
www.abb.com/substationautomation