



DEH 40012

GE PowerVac® 5kV VL

for PowerVac® Vacuum Circuit Breakers
Type PV VL 4.16-250-0
with ML-19 Mechanism

Instructions



DEH-40012

WARNINGS, CAUTIONS AND NOTES AS USED IN THIS PUBLICATION

This document is based on information available at the time of this publication. While efforts have been made to ensure accuracy, the information contained herein does not cover all details or variations in hardware and software, nor does it provide for every possible contingency in connection with installation, operation, and maintenance. Features may be described herein that are not present in all hardware and software systems. GE Industrial Systems assumes no obligation of notice to holders of this document with respect to changes subsequently made.

WARNINGS

Warning notices are used in this publication to emphasize that hazardous voltages, currents, or other conditions that could cause personal injury or death are present in this equipment or may be associated with its use.

Warning notices are also used for situations in which inattention or lack of equipment knowledge could cause either personal injury or damage to equipment.

CAUTIONS

Caution notices are used for situations in which equipment might be damaged if care is not taken.

NOTES

Notes call attention to information that is especially significant to understanding and operating the equipment.

GE Industrial Systems makes no representation or warranty, expressed, implied, or statutory, with respect to, and assumes no responsibility for the accuracy completeness, sufficiency, or usefulness of the information contained herein. No warranties of merchantability or fitness for purpose shall apply.

The following is a trademark of GE Company: PowerVac®

Chapter 1. Introduction	
1-1	Safety 6
1-2	Maintenance 6
Chapter 2. Description 7	
Chapter 3. Receiving, Handling & Storage	
3-1	Receiving 8
3-2	Handling 8
3-3	Storage 8
3-4	Safety Precautions 8
3-5	Unpacking the Breaker 8
3-6	Safety Interlocks 9
	Positive Interlock System 9
	Interference Bolts 10
Chapter 4. Installation	
4-1	Breaker Preparation 11
4-2	Equipment Test Position 11
4-3	Positive Interlock System 11
4-4	Checking for Proper Interlock 12
4-5	Primary Contact Penetration 14
4-6	Stationary Auxiliary Switch (MOC) 16
4-7	Stops 16
4-8	Ground 16
4-9	Secondary Coupler 17
4-10	Position Switch 17
Chapter 5. Operation	
5-1	Description 18
5-2	Close Spring Charging 19
5-3	Trip-Free Operation 20
5-4	Closing Operation 20
5-5	Opening Operation 21
Chapter 6. Control Circuit	
6-1	Typical Wiring Controls 22
Chapter 7. Mechanical Check and Slow Close	
7-1	Visual Inspection 25
7-2	Closing Spring Charging 25
7-3	Closing Spring Gag 25
7-4	Slow Closing 25
7-5	Gag Tool Removal 25
Chapter 8. Dimensional Checks	
8-1	Primary Contact Erosion 26
8-2	Spring Wipe Indicator 26
8-3	Contact Gap 27

Chapter 9. Electrical Checks

9-1	Electrical Operation	28
9-2	High Potential Test	28
	Primary Circuit	28
	Secondary Circuit	28
9-3	Primary Circuit Resistance	28
9-4	Vacuum Integrity Test	28
9-5	Insulation Tests	29

Chapter 10. Maintenance

10-1	General	30
10-2	Service Conditions	31
10-3	Fault Interruptions	31
10-4	Contact Erosion	31
10-5	Transfer Finger Wear	31
10-6	Mechanism	31
10-7	Primary Insulation Parts	31
10-8	Lubrication	32
10-9	Recommended Maintenance	32
10-10	Breaker Timing and Speed Check	32

Chapter 11. Mechanical Adjustments

11-1	General	35
11-2	Wipe Adjustment	35
11-3	Contact Gap Adjustment	36
11-4	Trip Coil Plunger	37
11-5	Close Coil Plunger	38
11-6	Control Switch Adjustment	39
11-7	Adjustment of MOC Switch	39
11-8	Positive Interlock	40

Chapter 12. Repair and Replacement

12-1	General	44
12-2	Replacing Interrupters	44
12-3	Primary Bushing	45
12-4	Mechanism	45
12-5	Control Switches	45
12-6	Trip Coil Replacement	45
12-7	Closing Coil Replacement	47
12-8	Auxiliary Switch Replacement	47
12-9	Motor Replacement	49
12-10	"Y" Relay Replacement	49

Chapter 13. Renewal Parts

13-1	Ordering Instructions	51
------	-----------------------------	----

Chapter 14. Stationary Cubicle Subassembly

14-1	Introduction	53
14-2	Major Components	53
14-3	Testing and Inspection	54
14-4	Compartment Maintenance	58

List of Figures

1. View of the 5kV 'VL' Breaker with Front Cover	7
2. Hooking lifting eyes	8
3. Manual Trip & Close	9
4. Positive Interlock	9
5. Rating Interference Bolt	10
6. Positive Interlock system	12
7. Manual charge handle	13
8. Primary Contact Insertion	14
9. Primary contact penetration and wipe	15
10. MOC switch	16
11. Secondary disconnect coupler	17
12. Front View of ML-19 Mechanism with Front Cover Removed	18
13. Charging & Trip system left side view	19
14. Manual Charging system right side view	19
15. Electrical Charging system right side view	20
16. Closing linkage left side view	20
17. Opening spring & auxiliary switch left side view	21
18. Wipe Spring assembly left side view	21
19. Typical ML-19 mechanism internal wiring connections	22
20. Typical breaker wiring diagram (Replacement for breakers with MS mechanisms	23
21. Typical breaker wiring diagram (Replacement for breakers with ML mechanisms	24
22. Closing spring with gag tool inserted	25
23. Contact Erosion Indicator	26
24. Primary contact erosion measurement-rear view	26
25. Wipe indicator check and wipe measurement-rear view	27
26. Sample Operating Speed Graphs	33
27. Opening Speed Adjustment	33
28. Travel Transducer Installation (Part#0144D1235G00X)	34
29. Wipe Insulator	35
30. Contact Gap Adjustment—Opening Buffer	36
31. Contact Gap measurement, wipe indicator check and wipe measurement	36
32. Trip coil gap adjustment	37
33. Trip coil button with gage	37
34. Trip coil assembly	37
35. Close coil assembly-front view	38
36. Close coil gap adjustment-front view	38
37. SM/LS & CHG switch adjustment-left side view	39
38. CL/MS and positive Interlock switch adjustment-right side view	39
39. Positive Interlock	40
40. Adjustment of MOC Switch/Plunger Interlock	41
41. Toggle Linkage Positions	42
41A Toggle Linkage Positions (View from Right Side)	42
42. Toggle Linkage Positions (View from Right Side)	42
42A Toggle Linkage Positions (View from Right Side)	42
43. Pole Assembly	44
44. Trip Coil and Linkage (Closing Spring Removed)	46
45. Front View of ML-19 Breaker Mechanism (Lower)	48
46. Front View of ML-19 Breaker Mechanism (Upper)	49
47. Motor Cutoff Switch	50
48. Closing Spring Gag	50
49. Front View of ML-19 Mechanism with Front Cover Removed	51
50. Schematic of ML-19 Mechanism	52
51. Typical stationary structure wiring	56
52. Electrical schematic diagram for vertical lift elevating mechanism	57
53. Positive interlock M-26 units	59
Appendix A	63

List of Tables

1. Measurements	43
2. Adjustments	43
3. ML-19 Control Devices and Voltages	47
4. Elevating Motor Troubleshooting	57

1-1 Safety

IT IS IMPERATIVE THAT ALL PERSONNEL ASSOCIATED WITH THIS EQUIPMENT READ AND COMPLETELY UNDERSTAND THE WARNINGS LOCATED THROUGHOUT THIS INSTRUCTION BOOK. FAILURE TO DO SO CAN RESULT IN DAMAGE TO PROPERTY OR PERSONAL INJURY.

Each user must maintain a safety program for the protection of personnel, as well as other equipment, from the potential hazards associated with electrical equipment.

The following requirements are intended to augment the user's safety program but NOT supplant the user's responsibility for devising a complete safety program. The following basic industry practiced safety requirements are applicable to all major electrical equipment such as switchgear or switchboards. GE neither condones nor assumes any responsibility for practices which deviate from the following:

1. ALL CONDUCTORS MUST BE ASSUMED TO BE ENERGIZED UNLESS THEIR POTENTIAL HAS BEEN MEASURED AS TO GROUND.

Many accidents have been caused by power system back feeds from a wide variety of sources.

2. It is strongly recommended that all equipment be completely de-energized, verified to be "dead", then grounded with adequate capacity grounding assemblies prior to any maintenance. The grounding cable assemblies must be able to withstand energizing fault levels so that protective equipment may clear the circuit safely. Additional discussion on this concept is covered in Chapter 20 of ANSI/NFPA 70B, Electrical Equipment Maintenance.

3. Although interlocks to reduce some of the risks are provided, the individual's actions while performing service or maintenance are essential to prevent accidents. Each person's knowledge; his mental awareness; and his planned and executed actions often determine if an accident will occur. The most important method of avoiding accidents is for all associated personnel to carefully apply a thorough understanding of the specific equipment from the viewpoints of its purpose, its construction, its operation and the situations which could be hazardous.

1-2 Maintenance

All personnel associated with installation, operation and maintenance of electrical equipment, such as power circuit breakers and other power handling equipment, must be thoroughly instructed, with periodic retraining, regarding power equipment in general as well as the particular model of equipment on which they are working. Instruction books, actual devices and appropriate safety and maintenance practices such as OSHA publications, National Electric Safety Code (ANSI C2), and National Fire Protection Association (NFPA) 70B Electrical Equipment Maintenance must be closely studied and followed. During actual work, supervision should audit practices to assure conformance.

2-1 Description

The PowerVac® 5kV VL vacuum circuit breaker is a vertical lift, removable and interchangeable interrupting element, for use in metal-clad switchgear to provide protection and control of electrical apparatus and power systems. The PowerVac 5kV VL Type PV-VL1 circuit breaker with ML-19 mechanism is available in continuous current ratings of 1200 and 2000 amperes in accordance with industry standards.

Refer to the breaker nameplate for complete rating information of any particular breaker. The nameplate also describes the control power requirements for that breaker. The application of a breaker must be such that its voltage, current and interrupting ratings are never exceeded. Since this book is written to include all ratings of the breaker, as well as several design variations, the instructions will be of a general character and all illustrations will be typical unless otherwise specified.



Figure 1. View of 5kV 'VL' Breaker with Front Cover

- | | | |
|-------------------------|------------------------------|--------------------------------------|
| 1 Nameplate | 5 Charge/Discharge Indicator | 9 Manual Charge Lever |
| 2 Cover Mounting Bolts | 6 Counter | 10 Secondary Coupler |
| 3 Front Removable Cover | 7 Manual Trip Button | 11 Positive Interlock Roller |
| 4 Open/Close Indicator | 8 Manual Close Button | 12 Plunger Interlock (MOC) |
| | | 13 Primary Bushings (1200 Amp shown) |

3-1. Receiving

Each breaker is carefully inspected before shipment. Immediately upon receipt of the circuit breaker, an examination should be made for any damage sustained in transit. If injury or rough handling is evident, a claim should be filed immediately with the transportation company, and the nearest GE Sales Office should be notified.

CAUTION: THE BREAKER HAS BEEN SHIPPED IN THE CLOSED POSITION.

3-2. Handling

It is expected that care will be exercised during the unpacking and installation of breakers so that no damage will occur from careless or rough handling, or from exposure to moisture or dirt. Loose parts associated with the breaker are sometimes included in the same crate. Check all parts against the packing list to be sure that no parts have been overlooked.

3-3. Storage

It is recommended that the breaker be put into service immediately in its permanent location. If this is not possible, the following precautions must be taken to assure the proper storage of the breaker.

The breaker should be stored in a clean location, free from corrosive gases or fumes. Particular care should be taken to protect the equipment from moisture and cement dust, as this combination has a very corrosive effect on many parts.

Breakers should be carefully protected against condensation, preferably by storing in a warm, dry room of moderate temperature such as 40 to 100° F. High humidity may have an adverse effect on the insulating parts and should be avoided. Circuit breakers for outdoor metal-clad switchgear should be stored in the equipment only when power is available and the heaters are in operation to prevent condensation.

Rollers, latches, etc. of the operating mechanism should be coated with GE part No. 0282A2048P009 (Mobil 28 red) grease to prevent rusting.

If the breaker is stored for any length of time, it should be inspected periodically to see that corrosion has not started. Should the breaker be stored under unfavorable atmospheric conditions, it should be serviced before being placed on line.

3-4 Safety Precautions

This circuit breaker uses powerful springs for energy storage. **DO NOT WORK ON THE INTERRUPTERS OR THE MECHANISM UNLESS THE CIRCUIT BREAKER IS IN THE "OPEN" POSITION AND BOTH THE CLOSING AND OPENING SPRINGS ARE EITHER DISCHARGED OR GAGGED AND ALL ELECTRICAL POWER IS REMOVED.**

The precautions are required to prevent accidental operation. Anyone working on the circuit breaker should be familiar with the contents of this instruction book.

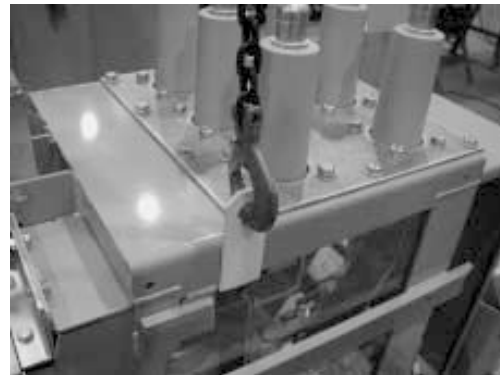

Figure 2. Hooking lifting eyes

3-5 Unpacking the Breaker

The circuit breaker has been supplied with a box of maintenance items. After removing the protective cardboard, locate this package and remove two each breaker lifting eyes. After removing the cleats that attach the breaker to the skid, hook the lifting eyes on both sides of the breaker in line with the front edge of the primary bushing plate at the point of the lifting arrows (see Figure 2). Connect a 1,000 lb. minimum rated chain fall or sling (not provided) to these lifting hooks and remove the breaker from the skid.

Packing List

With your breaker, you should have received:

1. Manual charging handle. (Part No. 0282A7227P001)
2. Gag tool. (Part No. 0209B8043G003)
3. Breaker Instruction Book DEH 40012
4. Elementary Wiring Diagram per breaker summary.
5. (1) Tube of GE red grease. (Part No. 0282A2048P010)
6. (2) Breaker lifting hooks . (Part No. 0348A3356P001)
7. (6) MOC adjustment washers. (Part No. 0348A3185P001)

CAUTION: THE CIRCUIT BREAKER HAS BEEN SHIPPED IN THE CLOSED POSITION.

After removing packing material, open the breaker by pushing in firmly on the manual trip button (Figure 2, Item 8), while keeping hands away from moving parts. A safe way to do this is to push on the trip button with the round side of the maintenance handle. Verify that the operation counter advances one count.



Figure 3. Manual Trip & Close

Closing and opening springs are now in their discharged positions. Check this by first pressing the manual close button, then the manual trip button. The indicator flags on the front of the breaker should show "OPEN" and "DISCHGD".

All mechanical and electrical checks listed in Chapter 4 should be completed before putting breakers in service.

3-6 Safety Interlocks

Each PowerVac® VL vacuum circuit breaker is provided with the following interlocks:

Positive Interlock System

The purpose of the positive interlock is to prevent moving the breaker to or from the connected position while the main contacts are closed, and to prevent closing the contacts unless the breaker is in the fully connected position. These important safety features are achieved by means of the positive interlock roller on the right side of the breaker and positive interlock cam and stationary "flag" in the switchgear cell.



*Figure 4.
Positive
Interlock*

A major goal in the design of switchgear has always been the interchangeability of breakers. GE Switchgear has been very successful in achieving that goal for many years. Analysis of instruction book adjustments, shop tolerances, and service advice letters issued in recent years, however, has demonstrated that tolerances in switchgear equipment installed and presently operating can change, resulting in situations where it is impossible to meet all adjustments. Also, when an adjustment is brought into specification it can cause a problem with another interface or adjustment.

Although GE has made every effort to assure interchangeability and satisfactory interface with existing equipment. Older equipment and field modifications that may have been made over the years, may require additional procedures before the new vacuum breaker can be installed in the cubicle. At a minimum, all breaker-to-switchgear interfaces as explained in this section should be verified for proper operation prior to energizing. The interfacing parts on all ratings of type AM breakers are functionally the same.

The following section defines the essential dimensions relating to the interfacing elements of the breaker and switchgear, to assure reliable performance. Some of these elements also affect the other important interfaces required for reliable operation of the equipment, such as:

1. Positive interlock safety feature.
2. Mechanism operation.
3. Primary disconnect penetration.
4. Secondary coupler penetration.

Interference Bolts

This interlock permits only a breaker with a matching continuous current rating to be inserted into a metal-clad compartment of identical rating. The rating interference bolt has been assembled to match the current rating of the compartment. This assembly is done by fastening a bolt on the lower left side of the breaker truck to align with the proper cubicle interference plate. This bolt should not be removed. Figure 5.

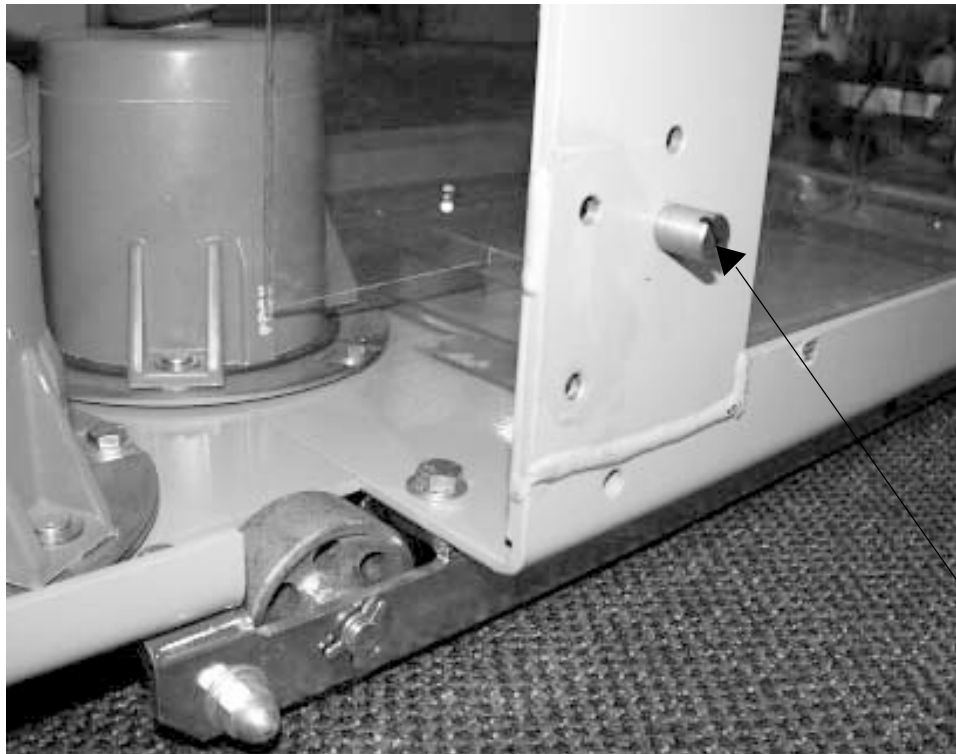

Figure 5. Rating Interference Bolt

4-1 Breaker Preparation

Prior to interfacing the breaker into the switchgear cell, rub a small amount of 0282A2048P009 red grease, provided with the breaker, on the silvered portion of the breaker studs, ground shoe, and 16 secondary coupler pins, to form a thin coating for contact purposes.

4-2 Equipment Test Position

In most AM breaker Metal-Clad Switchgear units, there is a breaker "Test Position" which allows you to functionally test the breaker without connecting to the bus. This position is lowered fully down from the breaker being fully connected into the cubicle. When in the "test position", a secondary coupler cable must be used to connect the secondary control circuits for electrical breaker operation.

While in the test position, the breaker interlock is not activated. The interlock roller will not rest in the lower "Vee" notch in the equipment interlock cam plate allowing the operator to close and open the breaker electrically or manually (see Figure 6).

The breaker positive interlock system should be checked while in the test position prior to elevating the breaker.

WARNING: FAILURE TO PROPERLY VERIFY ALL BREAKER SWITCHGEAR INTERFACES AND PROPER POSITIVE INTERLOCK OPERATION COULD RESULT IN A BREAKER OPERATIONAL FAILURE.

4-3 Positive Interlock

The positive interlock system prevents connecting or disconnecting the breaker in the cubicle, when the breaker is in the closed position and the vacuum contacts are closed.

This interlock feature is accomplished by a roller and lever located on the interlock shaft, on the right side of the breaker. (Figures 1, 4 and 6) The positive interlock lever (roller) provides a trip-free and discharged condition when racking the breaker in the connected or disconnect position. When the breaker is raised or lowered,

the positive interlock roller and lever are forced forward by the positive interlock cam on the right side of the switchgear cell. The interlock roller and lever are held in this forward position during raising and lowering operations, preventing the breaker from being closed in any intermediate position between the connect and the fully lowered position. Any attempt to charge the breaker will cause the stored energy springs to automatically discharge without the breaker contacts closing or moving. The breaker must be fully connected (raised) and the clutch handle must be released before the breaker can be closed. Releasing the clutch handle allows the interlock cam plate in the cell to move downward allowing the interlock roller and lever to return to their normal vertical positions. The breaker may then be closed.

The following positive interlock adjustments are made at the factory and verified for proper operation per Figure 6. The distance from the top of the stationary flag to the top of the switchgear guide rails is set. This maintains the surface upon which the breaker wheels rest when the breaker is lowered. The upper elevating motor limit switch is then adjusted to achieve a roller to flag clearance of 1/16" to 1/8" as shown in Figure 6. The limit switch de-energizes the elevating motor circuit and should be activated when the primary disconnects and secondary coupler reach their nominal contact penetration position. If the timing of this sequence is off, the cell must be adjusted back to factory specifications.

Typical instructions for making adjustments to the cell positive interlock cam as provided with the original equipment are outlined in Figure 6 and Figure 53.

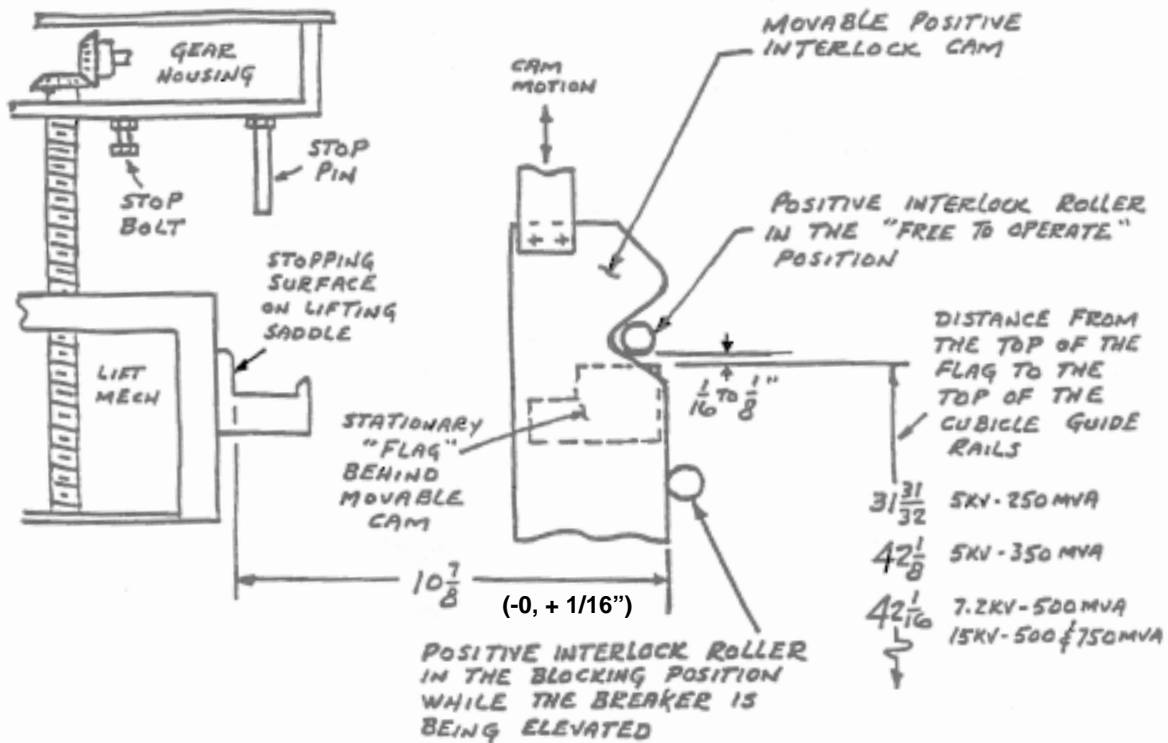

Figure 6. Positive Interlock system

4-4 Check for Proper Interlock and Trip-free Functions Before Energizing the Breaker

WARNING: THE PRIMARY EQUIPMENT SHOULD BE COMPLETELY DE-ENERGIZED WHILE THE TESTS ARE IN PROGRESS. DO NOT INSTALL OR REMOVE THE BREAKER OR MAKE ADJUSTMENTS UNLESS THE BREAKER IS OPEN.

To test the function of the positive interlock system and trip free function, the following checks should be made:

1. Verify that red grease has been rubbed on the silvered portion of the breaker studs, ground shoe, and 16 secondary coupler pins, forming a thin coating for contact purposes.
2. Before inserting the New VL vacuum breaker into the cubicle, verify the cubicle interlock position by measuring the distance between (Figure 6) the movable positive interlock cam to the back of the lifting saddle of the racking mechanism. This distance should be 10 7/8" minus 0, plus 1/16".

3. Lower the elevating mechanism lifting brackets until the lifting brackets are in the fully lowered position. The breaker should then enter the housing freely. After first assuring that the breaker is in the open position, push the breaker into the unit until it rests against the rear of the front lifting saddle of the elevating mechanism. The clearance between the interference block on the breaker and the interference block on the interlock mechanism should be from .063" to .125".

4. With the breaker in the lowered position, the positive interlock roller engages in the lower Vee notch, in the interlock cam plate. **The breaker should be in the opened position and the closing springs discharged** as indicated by the flag indicators. (Figure 1, items 4 and 6) Using the manual charging handle, charge the breaker. Then close the breaker and recharge. (Figure 7, Item 1). With the elevating motor switch in a neutral position engage the clutch to verify the operation of the positive interlock. The springs will discharge and the breaker will open.

NOTE: TABLE 3, FIGURES 6, 52, 53, AND 54 HAVE BEEN PROVIDED TO FAMILIARIZE THE OPERATOR WITH THE EQUIPMENT RACKING SYSTEM AND TROUBLESHOOTING.

WARNING: AGAIN, BEFORE PROCEEDING WITH THIS CHECK, IT IS NECESSARY THAT THE PRIMARY CIRCUITS BE DE-ENERGIZED.

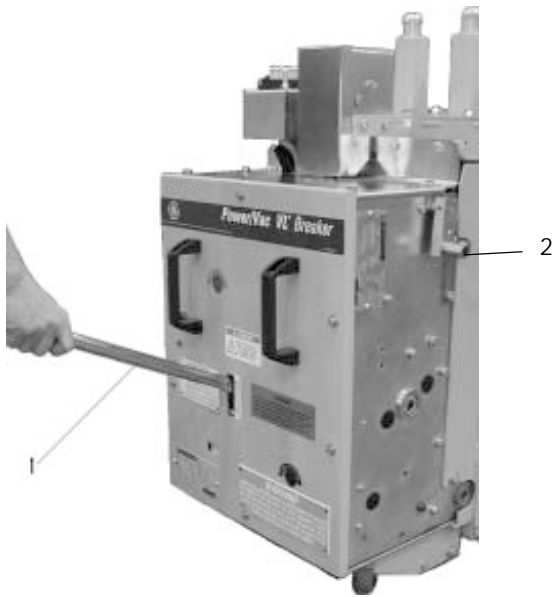

- 1 Manual charging handle
- 2 Positive interlock

Figure 7. Manual charge handle

WARNING: DO NOT ATTEMPT TO MANUALLY CHARGE A CHARGED BREAKER. TO DO SO COULD DAMAGE THE CHARGING CLUTCH AND MAKE THE MANUAL CHARGING FEATURE INOPERABLE.

5. Raise the breaker to the connect position. This can be done manually with an elevating wrench or electrically with an elevating motor provided with the original equipment.

To elevate the breaker, first—verify the breaker is in the open position and the closing springs are discharged. Place the elevating control selector switch on the elevating motor to “RAISE”. A clutch handle under the elevating motor is then pulled forward until a limit switch engages to raise the breaker into the unit. Carefully raise the breaker and while elevating, note that the shutter slides open and the breaker studs center with respect to the openings in the stationary disconnecting devices or damage to the contacts may result.

6. Hold the clutch handle in the forward position until a limit switch on the structure opens to stop the motor at the end of the upward travel of the breaker. The springs will charge when the clutch handle is released.

CAUTION: THE MOTOR RAISE/LOWER SELECTOR SWITCH MUST NOT BE USED TO ENERGIZE OR INTERRUPT MOTOR CIRCUIT AT ANY TIME.

7. When the breaker is fully elevated, the clearance between the breaker lifting rail and the upper stop bolts should not be more than .125" and not less than .094".
8. The positive interlock roller should be centered in the upper “VEE” and the interlock roller should have 1/16" clearance to the stationary plate directly under it.
9. In order to lower the breaker from the connected position, the **breaker should be open**. The closing springs will be discharged when the clutch handle is engaged.

To lower the breaker, place the elevating control selector switch on the elevating motor to “lower”. A clutch handle in back of the elevating motor is then pulled forward until a limit switch engages, to lower the breaker to the bottom of the cubicle.

10. To raise or lower the breaker, the clutch must be held in the engaged position, otherwise a spring will return it to its disengaged position and open the electrical circuit to the motor.

CAUTION: THE POSITIVE INTERLOCK LEVER ROLLER WILL DISCHARGE THE OPENING AND CLOSING SPRINGS AS THE ELVATING MOTOR CLUTCH IS ENGAGED.

11. The breaker may be raised or lowered by an emergency hand crank which can be inserted after removing the motor. The motor is removed by unlatching the motor assembly from its support and disconnecting the motor lead plug. After removing the motor, insert the manual crank and pull the clutch forward. Rotate the crank until the coupling engages the clutch. The clutch handle will be held in the down position by a latch on the crank assembly. The breaker must be open before the crank can be inserted and held in the clutch coupling.

When the breaker is in the fully elevated and in the connected position, releasing the motor operating handle will return the positive interlock roller into the upper Vee notch in the interlock cam plate. The breaker positive interlock switch will close and energize the motor charging circuit allowing the closing spring to charge. The breaker may now be closed.

In order to lower the breaker from the connected position, the breaker should be opened. If the breaker has not been opened, operating the motor elevating clutch will open the contacts and discharge the springs.

4-5 Primary Contact Penetration

After completing the Positive Interlock and trip free functional checks, lower the breaker and withdraw it from the cell. Inspect the contact surfaces of both the breaker studs and the stationary disconnecting devices. The primary disconnect devices utilize silver to silver contacts to insure against reduction of current carrying capacity due to oxidation of the contact surfaces. These contacts are of the high pressure line contact tube and socket design, the tube being backed up by heavy garter springs.

1. Each segment of the stationary disconnecting device should make a heavy impression in the contact lubricant on the breaker studs as shown in Figure 9. Contact wipe should start not less than .125" from the top of the contact ball, although each contact need not start at the same location.
2. The penetration of the breaker stud inside the stationary disconnecting device, as indicated by the contact lubricant, should be 3/4" to 7/8" as shown in Figure 9. This indicates that the breaker studs contacted at the full pressure center of the silver band on the stationary disconnecting device correctly.
3. Should the inspection of the contacts show that the breaker is not being raised to the proper position, readjust the upper stop bolts and limit switches to raise or lower the breaker to the proper location (See Figure 6 and 53). Lock the stop bolts in the new position.
4. If proper contacting cannot be attained by the above methods, additional adjustments may be necessary.

Contact the local GE Sales Office for factory assistance.

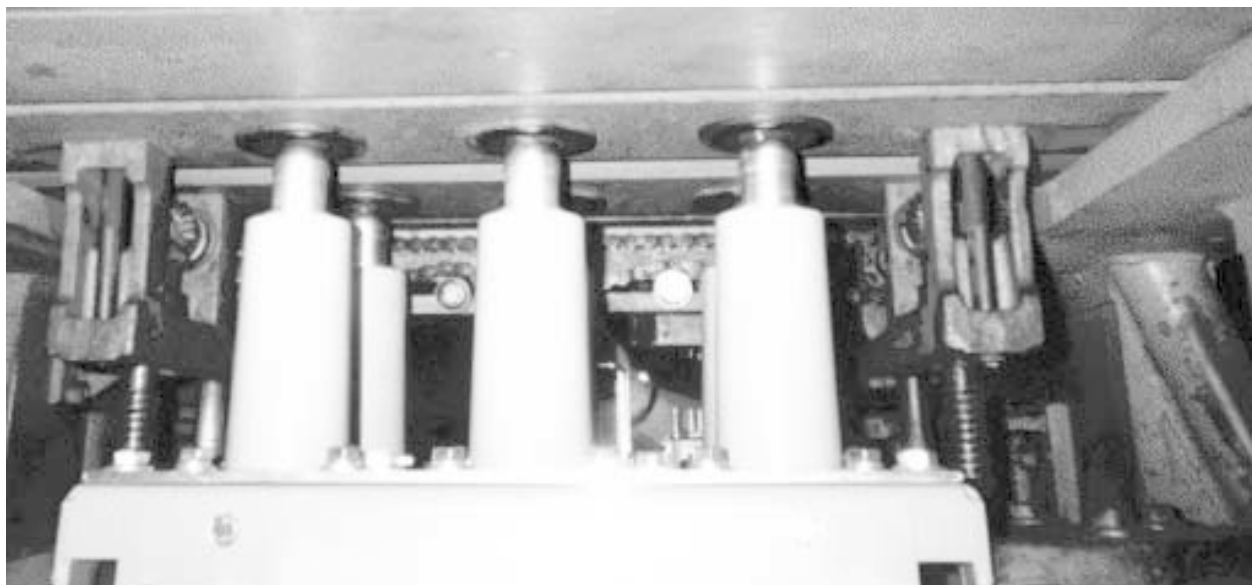

Figure 8. Primary Contact Insertion

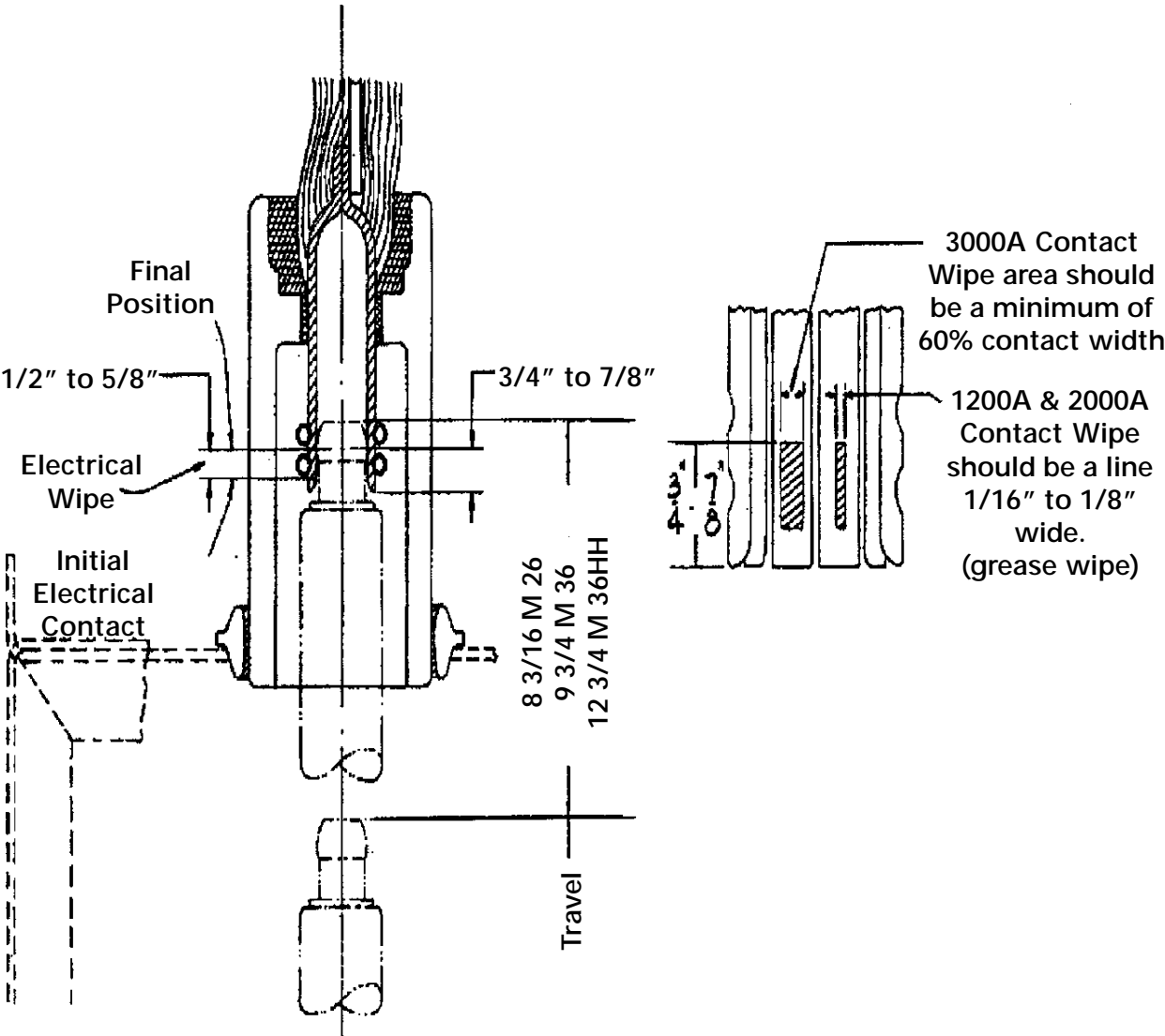

Figure 9. Primary contact penetration and wipe

4-6 Stationary Auxiliary Switch (MOC)

The Stationary Auxiliary Switch is a Mechanism Operated Contact (MOC) which is an optional switch mounted in the switchgear cell. When the breaker has been elevated to the fully connected position, the MOC switch will be actuated whenever the breaker is closed. The MOC switch is actuated by the plunger mounted on the top of the breaker mechanism. (Figure 10 Item 1). The MOC switch has a number of "a" contacts (closed when the breaker is closed and open when the breaker is open) and "b" contacts (open when the breaker is closed and closed when the breaker is open).

The following paragraph defines the essential dimensions relating to the interfacing elements of the beaker and switchgear, to assure reliable performance.

The following elements are important factors which commonly affect the operation of the stationary auxiliary switch.

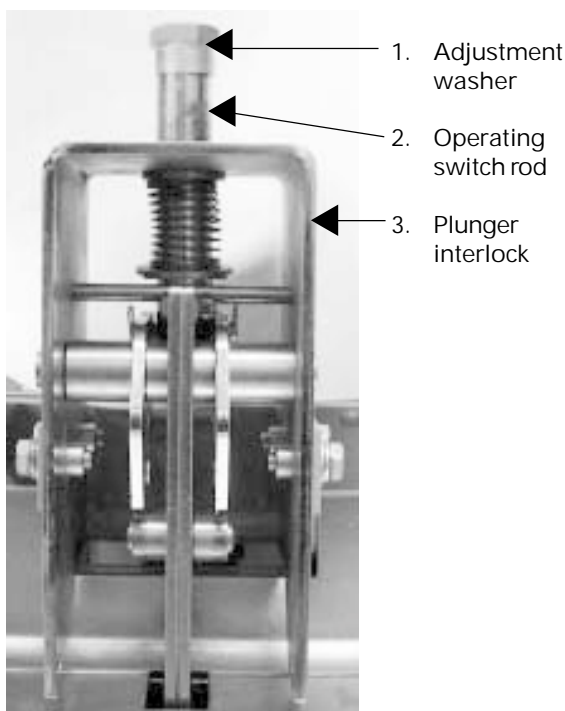

Figure 10. MOC switch

1. Plunger travel on the breaker.
2. The gap between the top of the plunger on the breaker and the bottom of the rod on the stationary auxiliary switch mechanism.
3. Variations between breakers in the distance from the underside of the lift rail and the top of the plunger.
4. Variations in the rotation requirements to "make" and "break" the stationary auxiliary switch contacts.
5. Condition of the plunger interlock components on the breaker.
6. Elevating mechanism limit switch consistency.
7. Break elevating mechanism positive stops.
8. Seismic events.

Some of these elements also affect the other important interfaces required for reliable operation of the equipment, such as:

1. Primary disconnect penetration.
2. Secondary coupler penetration.
3. The positive interlock mechanism.

A major goal in the design of switchgear has always been the interchangeability of breakers. GE Switchgear has been very successful in achieving that goal for many years. Analysis of instruction book adjustments, shop tolerances, and service advice letters issued in recent years, however, have demonstrated that tolerances in switchgear equipment installed and presently operating can result in situations where it is impossible to meet all adjustments or that an adjustment is brought into specification and it causes a problem with another interface.

4-7 Stops

The stop pins and stop bolts on the elevating mechanism are emergency mechanical stops which would come into use only if the upper elevating motor switch is completely out of adjustment or has failed. Elevating against these stops may be quite audible and the operator should release the clutch handle immediately, de-energizing the elevating motor circuit or the elevating motor circuit protective fuse will open to protect the motor. The stop bolts should be set to 3/32" to 1/8" clearance and only changed or reset after all other elevating adjustments are made and verified. Figure 6 and 53.

4-8 Ground

A visual check should be made to observe the ground connection. The ground shoe on the moveable breaker is designed to have a nominal engagement of 1-1/2" +1/4" vertically with the steel and copper spring loaded disconnects of the ground device in the switchgear.

4-9 Secondary Coupler

On the top left front of the breaker, there is a plastic block which holds the male secondary coupler pins. This block should make contact with, and slightly raise a spring loaded plastic block which holds female secondary coupler sockets on the switchgear. The contact depression should be $1/8"$. It is not always possible to have the plastic blocks in contact over their entire flat surface. Often, the rear of the blocks are engaged while a gap exists along the front edge. This is an acceptable condition. The contacting block surfaces should touch and the female block edge move upward between $1/32"$ to $1/8"$. See Figure 11.

4-10 Position Switch (TOC)

The position switch is an optional device mounted in the rear left side of the switchgear cubicle. The switch contacts operate when the lifting mechanism is in either the fully raised or fully lowered position. Switch operation should be checked with the breaker withdrawn manually and the equipment de-energized, and again electrically, with the breaker in the cubicle.

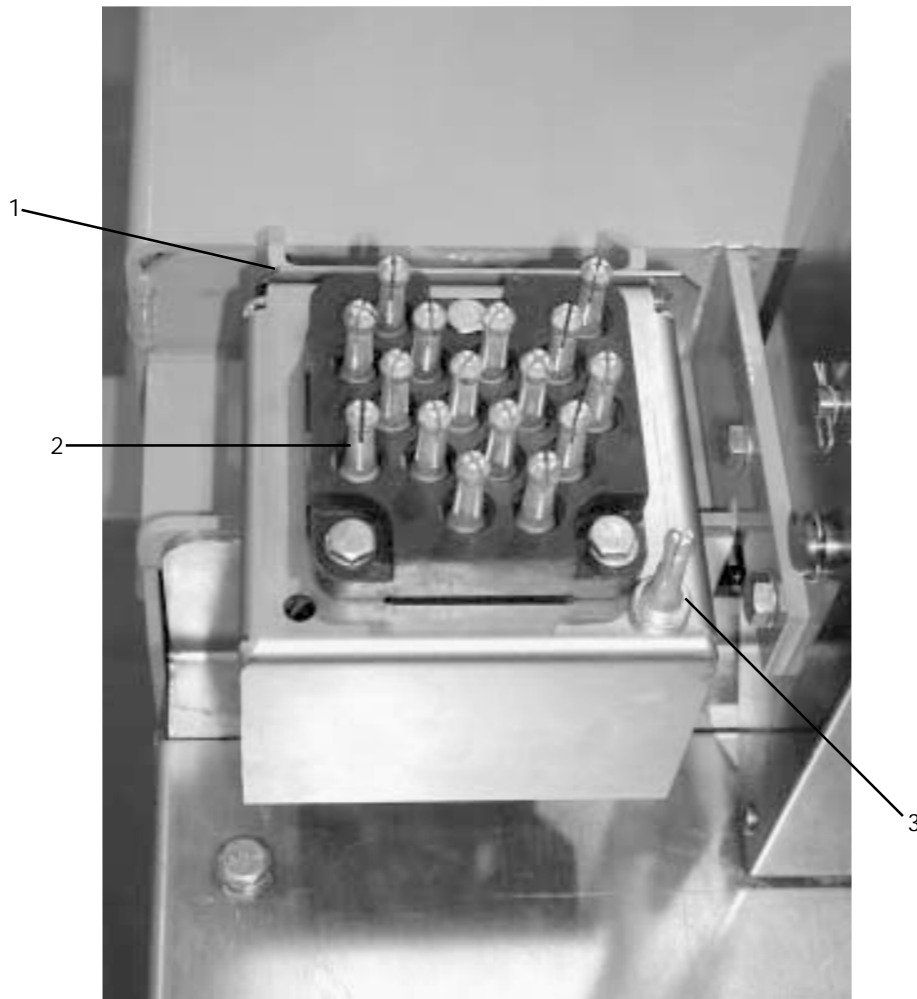

- 1 Secondary disconnect block shims
- 2 16 Secondary disconnect pins
- 3 Ground pin for use with a test cabinet

Figure 11. Secondary disconnect coupler

5-1 Description

The PowerVac® 5kV VL vacuum circuit breaker uses a sealed vacuum power interrupter to establish and interrupt a primary circuit. Primary connections to the associated metal-clad switchgear are made by pole assemblies, electrically and mechanically connected to the vacuum interrupters. The operating mechanism provides vertical motion at each pole location in order to move the lower contact of the vacuum interrupters from an open position to a spring-loaded closed position and then back to the open position on command.

The ML-19 mechanism (Figure 12) is a stored-energy type mechanism and uses a gear motor to charge a closing spring. During a closing operation, the energy stored in the closing spring is used to close the vacuum interrupter contacts, charge the wipe springs which load the contacts, charge the opening springs, and overcome bearing and other frictional forces.

The energy then stored in the wipe and opening springs will open the contacts during an opening operation.

Closing and opening operations are controlled electrically by the control switch on the metal-clad door or remote relaying.

Mechanical control for maintenance or emergencies is provided by manual close and trip buttons on the circuit breaker.

Also, the closing spring may be manually charged (Figure 7) for de-energized checks and maintenance.

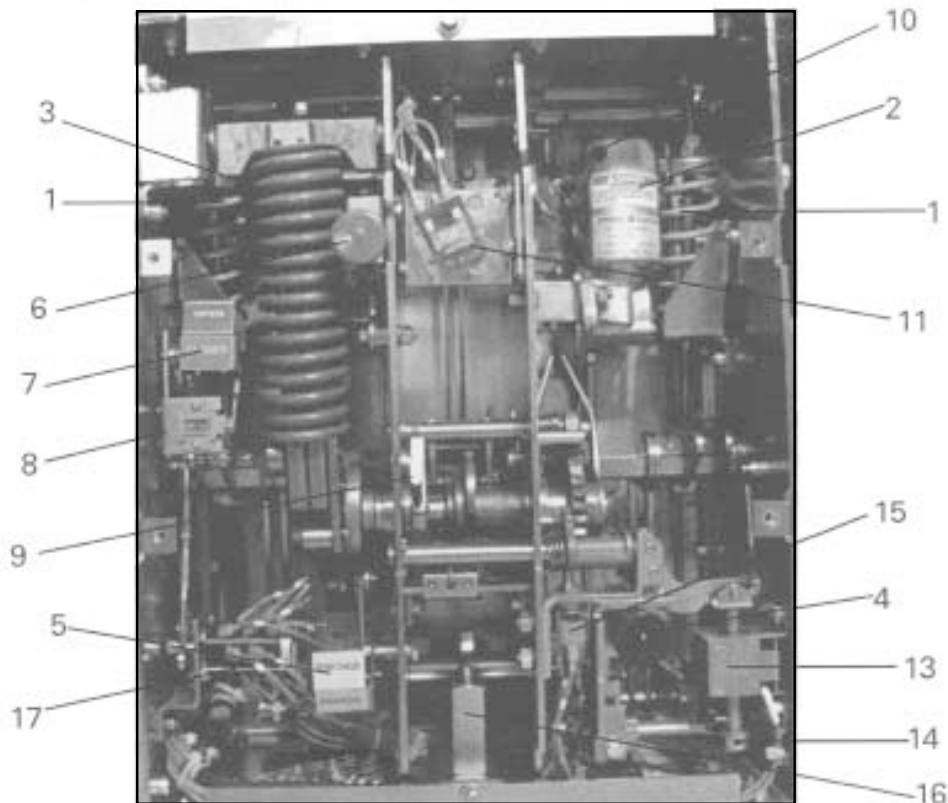

Figure 12. Front View of ML-19 Mechanism with Front Cover Removed

- | | | | | | |
|---|----------------------------|----|---------------------------|----|------------------------------|
| 1 | Opening Spring | 8 | Counter | 14 | Close coil adjustment collar |
| 2 | Charging Motor | 9 | Manual Charge Lever | 15 | Close latch check switch |
| 3 | Close Spring | 10 | Positive Interlock Switch | 16 | Opening dashpot |
| 4 | Manual Close Button | 11 | Close Relay | 17 | Auziliary switch |
| 5 | Charge/Discharge Indicator | 12 | Cam shaft | 18 | MOC Plunger linkage |
| 6 | Manual Trip Button | 13 | Close coil | 19 | Positive interlock bar |
| 7 | Open/Close Indicator | | | | |

5-2 Close Spring Charging

Figure 13 shows a left side view of the closing spring. The closing spring is charged and ready to close. The closing spring charging system consists of a closing spring mounted on the left side of the breaker and the electrical charging system mounted on the right side of the breaker. Both components are fastened to the cam shaft (Figure 13, Item 2).

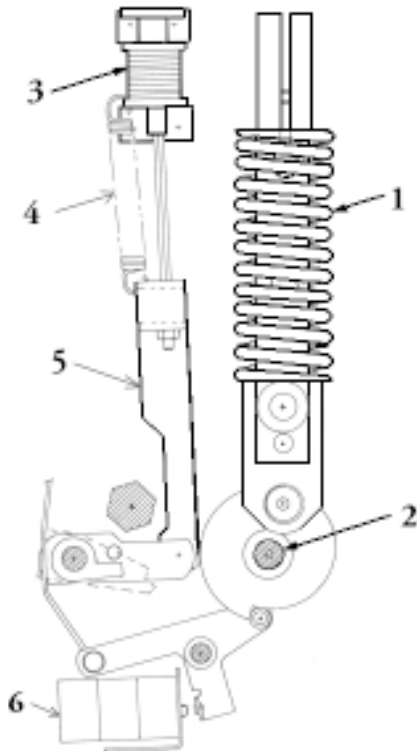

Figure 13. Charging & Trip system left side view

- | | |
|------------------|-------------------------|
| 1 Closing spring | 4 Trip return spring |
| 2 Cam shaft | 5 Trip linkage |
| 3 Trip Solenoid | 6 52 Chg & SM/LS switch |

A manual charging system is provided to manually charge the breaker, or while under maintenance so that the mechanism can be slow closed and the closing spring can be charged. (Figure 14, Item 1)

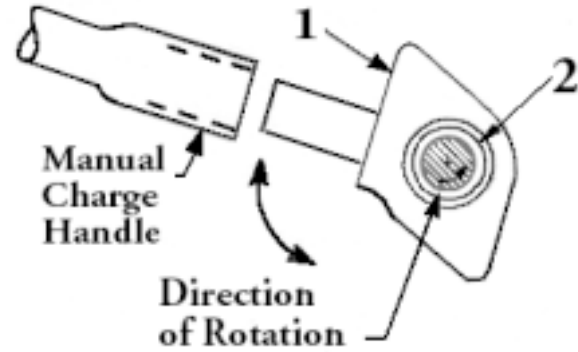

Figure 14. Manual Charging system right side view

- 1 Manual charging crank
- 2 One way clutch

WARNING: DO NOT ATTEMPT TO MANUALLY CHARGE A CHARGED BREAKER. TO DO SO COULD DAMAGE THE CHARGING CLUTCH AND MAKE THE MANUAL CHARGING FEATURE INOPERABLE.

The manual charging system (Figure 14) works directly on the cam shaft where a one-way clutch (Figure 14, Item 2), driven by a manual handle, provides rotation of the ratchet wheel. Manual pumping of the handle advances the ratchet wheel and the holding pawl prevents counter-rotation while the handle is returning for another stroke. Approximately eight complete strokes of the manual handle are required for one complete spring-charging operation.

When the spring charge indicator (Figure 1, Item 5) shows "CHARGED", MANUAL CHARGING MUST BE DISCONTINUED TO AVOID MECHANISM DAMAGE.

Spring charging is accomplished electrically by a rotating eccentric on the output shaft of a gear motor (Figure 15, Item 6) which in turn drives pivoted charging arms (Figure 15, Item 1). The charging arms oscillate about the centerline of a ratchet wheel (Figure 15, Item 2). A driving pawl (Figure 15, item 3), mounted within the charging arms, oscillates with the charging arms. Starting from its rear-most position, the charging arms rotate forward, while spring forces engage the driving pawl with a tooth on the ratchet wheel. The ratchet wheel is advanced by the rotating charging arms and pawl assembly. Advancement of one tooth spacing is provided for each oscillation of the system. The ratchet motion is restricted to one direction by a spring-loaded holding pawl (Figure 15, Item 4) that prevents the ratchet wheel from going backwards as the charging arm oscillates back to pick up the next tooth. Thirteen complete cycles of the charging arms are needed for a full charge of the closing spring. The efficient, compact gear motor accomplishes this action in about two seconds. When the charging cycle is complete, the ratchet wheel is positioned so that a missing tooth is adjacent to the driving pawl and any motor overspin will not drive the ratchet wheel, thus preventing damage to the system.

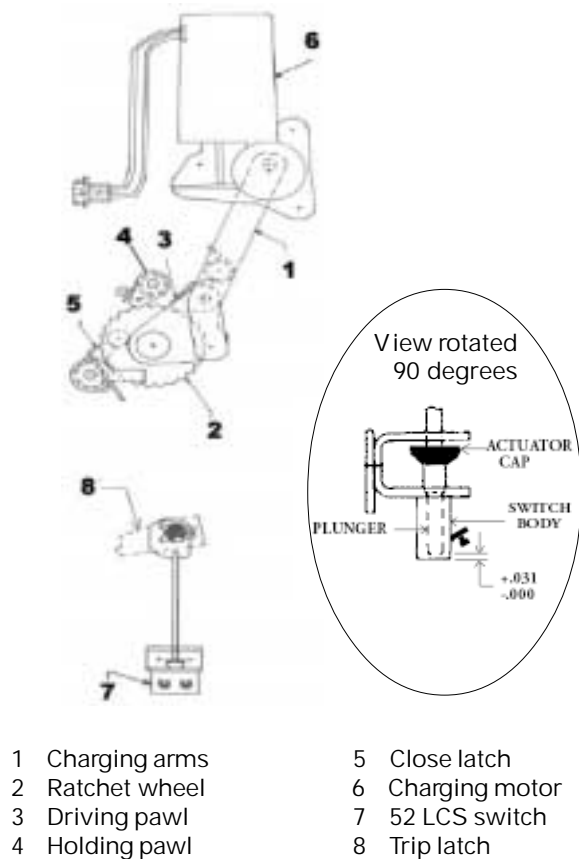
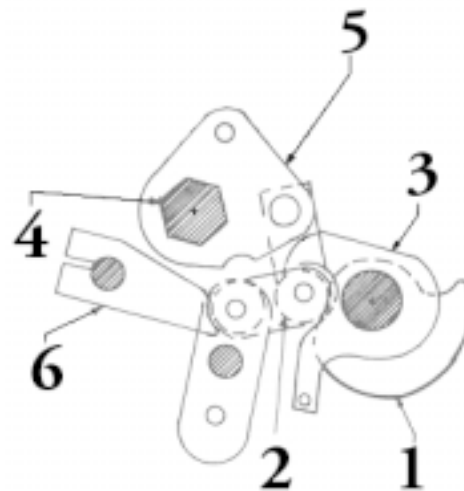

Figure 15. Electrical Charging system right side view

The closing coil cannot be electrically energized unless the closing spring is completely charged. This action is prevented by the 52/CHG switch in the closing circuit. (Figure 13, Item 6)

5-3 Trip Free Operation

The linkage is mechanically trip-free in any location on the closing stroke. Electrically energizing the trip coil while closing will, after the auxiliary switch contacts change position, rotate the trip latch and permit the circuit breaker to open fully. The linkage will reset as in a normal open operation and the closing spring will recharge as described under "CLOSE SPRING CHARGING".



- | | |
|--------------------|-----------------------|
| 1 Closing cam | 4 Primary cross shaft |
| 2 Closing roller | 5 Primary drive crank |
| 3 Close prop latch | 6 Trip latch |

Figure 16. Closing linkage left side view

5-4 Closing Operation

By either energizing the close solenoid or depressing the manual close button (Figure 1, Item 8) the close latch (Figure 15, Item 5) is rotated, releasing the closing spring (Figure 13, Item 1). This action releases the energy in the closing spring and transmits it to the closing cam (Figure 16, Item 1) and closing roller (Figure 16, Item 2) causing the linkage to rise until the close prop (Figure 16, Item 3) can slip under the close roller (Figure 16, Item 2) and hold the linkage in place. As the linkage moves, the primary drive crank (Figure 16, Item 5) rotates the primary cross shaft (Figures 16 & 17, Item 4) which in turn rotates the outer phase bell cranks. (Figure 17, item 2)

The rotation of the primary cross shaft rotates two outer phase bell cranks which compress the outer opening springs (Figure 17, Item 1). The primary cross shaft also rotates two sets of inner drive cranks that in turn rotate two outer sets of secondary drive cranks, (Figure 18, Item 2) As the outer secondary drive cranks rotate about the secondary cross shaft, the center drive cranks are rotated. The rotation of the secondary drive cranks close the vacuum interrupters, and compresses the wipe springs on all three phases. (Figure 18, Item 1) The interrupters are driven closed through insulated operating rods. (Figure 18, Item 4). This interrupters are driven closed through insulated operating rods (Figure 18, Item 4)

The rotation of the primary cross shaft (Figure 17, Item 4) also changes the auxiliary switch position. (Figure 17, Item 3) The position flag on the front panel will then indicate "CLOSED". After the breaker is closed, the charging motor is again energized and the closing spring is charged as described under "CLOSE SPRING CHARGING". Spring charging is possible when the breaker is in the closed position because the linkage is held in place by the prop.

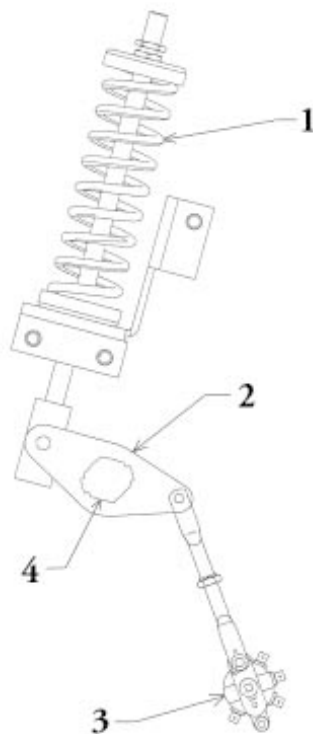

- | | |
|---------------------|-----------------------|
| 1 Opening Spring | 3 Auxilliary switch |
| 2 Outer bell cranks | 4 Primary cross shaft |

Figure 17. Opening spring & auxilliary switch left side view

5-5 Opening Operation

By either energizing the trip solenoid (Figure 13 Item 3) or depressing the manual trip button (Figure 1, Item 7), the trip latch (Figure 16, Item 6) is rotated, permitting the linkage to collapse. The vacuum interrupter contacts will then open under the force of the wipe springs (Figure 18, item 1) and opening springs (Figure 17, item 1). At the end of the opening stroke, the center phase secondary drive cranks hit the dashpot limiting overtravel and rebound.

Rotation of the Primary cross shaft from the closed to the open position operates the auxiliary switch (Figure 17, Item 3) opening the trip coil circuit. When the closing spring has been recharged, (Figure 13, Item 1) the linkage is reset allowing the trip latch (Figure 16, Item 6) to rest in place on the trip roller, ready for another closing operation. If the closing spring has not been recharged, the trip latch will be held out of position. A latch-checking switch, 52 LCS (Figure 15, Item 7) will not close unless the latch is in its normal position. The contacts of the latch-checking switch are part of the closing circuit and will not allow for an electrical close until the latch is reset.

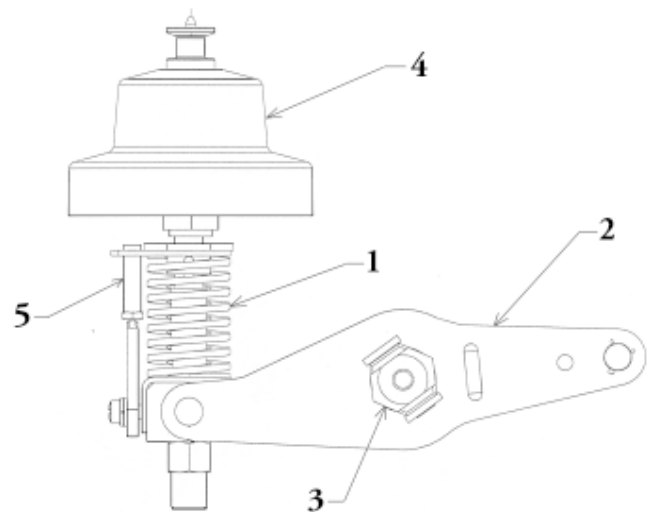

- | | |
|-------------------------|---------------------------|
| 1 Wipe spring | 4 Insulated operating rod |
| 2 Secondary drive crank | 5 Wipe indicator |
| 3 Secondary cross shaft | |

Figure 18. Wipe Spring assembly-left side view

6-1 Controls

A Standard internal wire harness for a PowerVac® VL circuit breaker ML-19 mechanism is shown in Figure 19. The wiring from the breaker internals to the secondary disconnect varies with each breaker. Two typical breaker wiring diagrams have been provided (Figure 20 and Figure 21). Always follow the wiring diagram supplied with the actual circuit breaker for trouble shooting purposes.

The close spring-charging motor circuit is established through the CL/MS (Close Latch Monitor Switch) Switch, if the close latch is reset and the SM/LS (Spring Motor Limit Switch) Switch is closed, the motor will charge the closing spring. When the closing spring is charged, the SM/LS interrupts the circuit.

The close coil circuit is established through two normally closed 52Y relay contacts, and the Latch Checking Switch (LCS). If the trip latch is reset, an auxiliary switch contact 52b is also in series with the close coil and closes when the breaker is open and opens when the breaker is closed.

During a close operation, the cam rotation closes the SM/LS contact allowing the 52Y relay to be energized. The 52Y relay opens its contacts, in the close coil circuit and seals itself in through one of its own contacts. This seal-in action prevents re-closing on a sustained close command. The close signal must be removed to drop out the 52Y relay and reestablish the closing circuit. This provides the anti-pump feature.

Circuit breaker-mounted auxiliary switch contacts that are not used in the control circuit are brought out for control and indication functions. The metal-clad equipment may provide a breaker-operated stationary auxiliary switch for additional contacts.

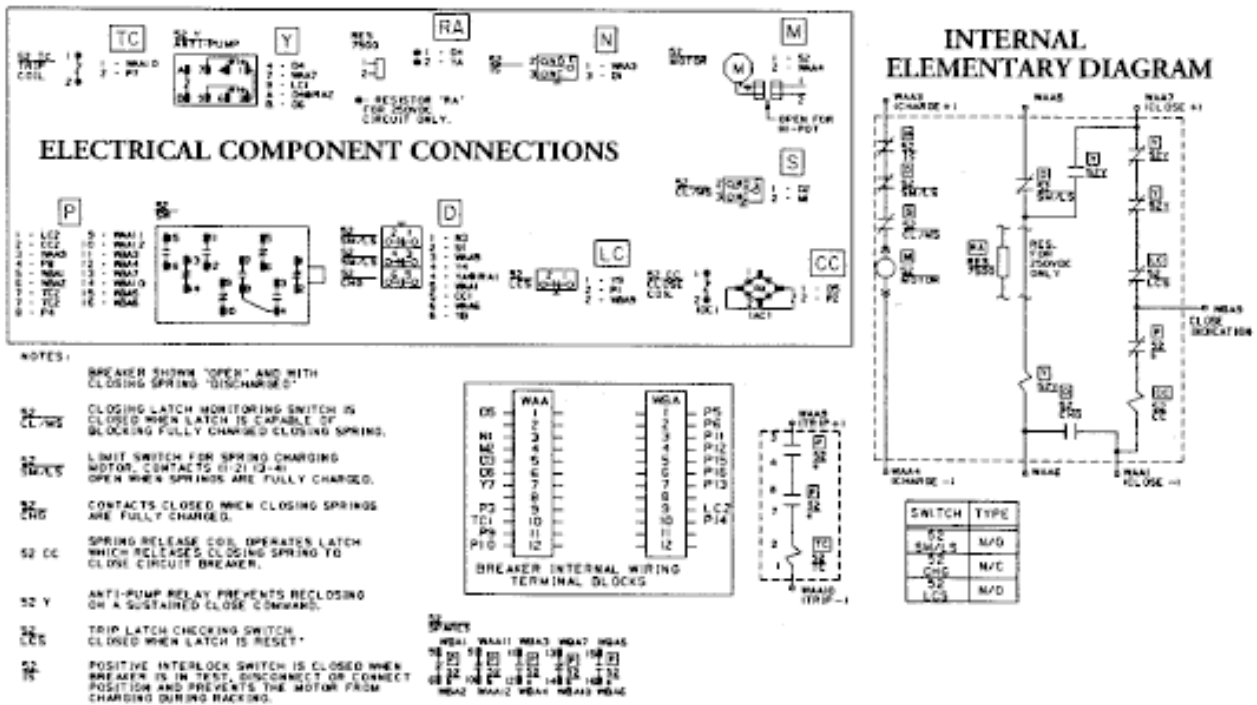

Figure 19. Typical ML-19 mechanism internal wiring connections.

Figures 20 and 21 show typical wiring diagrams for PowerVac® VL breakers.

Replacement breakers for old units with solenoid mechanisms (AM breakers with MS type mechanisms) are typically wired per the drawing in Figure 20.

Replacement breakers for old units with stored energy mechanisms (AM breakers with ML type mechanisms) are typically wired per the drawing in Figure 21.

The wiring on your breakers may be different. Consult your nameplate for the correct drawing number and call your local GE office when additional copies of this drawing are required.

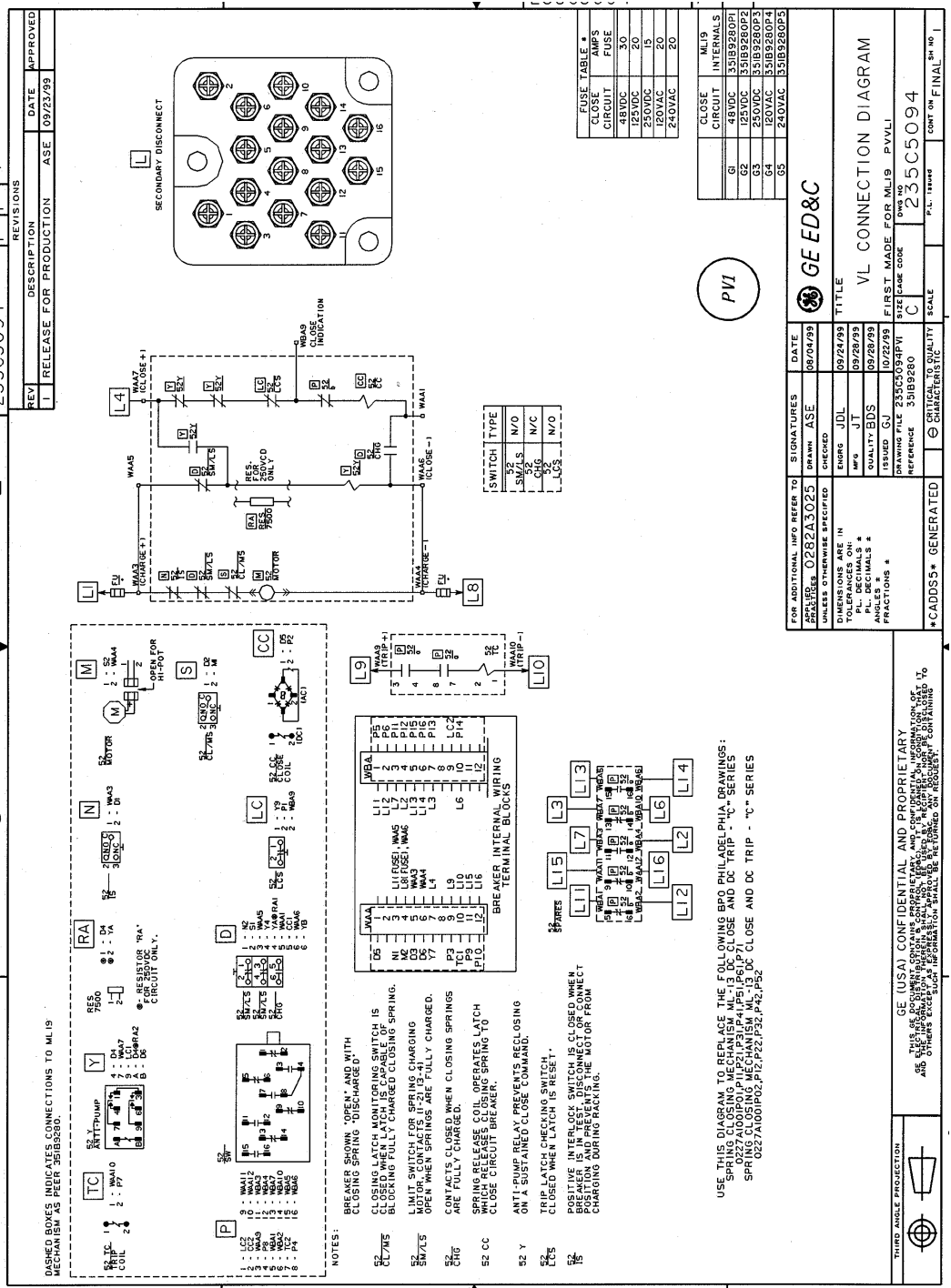

Figure 20. Typical breaker wiring diagram (Replacement for breakers with MS mechanisms)

7-1 Visual Inspection

Visually inspect the circuit breaker for any signs of damage or loose hardware.

7-2 Closing Spring Charging

Manually charge the breaker closing spring using the charging handle provided. (Figure 7, Item 1) The closing spring is charged by a ratcheting mechanism that advances one ratchet tooth at a time. Approximately eight complete strokes are required. When the spring is fully charged, the spring load is held by the closing latch. The spring indicator (Figure 1, Item 5) changes from "DISCHGD" to "CHARGED", and a positive snap is heard as the spring travels over center.

CAUTION: AFTER THE SPRING IS COMPLETELY CHARGED, AS INDICATED ABOVE, FURTHER FORCING THE CHARGING HANDLE MAY CAUSE DAMAGE TO THE CLOSING LATCH AND ITS ASSOCIATED PARTS.

7-3 Closing Spring Gag

Remove the mechanism front and top covers and insert the tip of the closing spring gag tool (Figure 22, Item 2) between the end of the spring and the spring guide, engaging the détentes (Figure 22, Item 3) on the gag tool into the slots in the closing spring guide. (Figure 22, Item 4) Reference also Figure 48.

With the gag tool in position depress the manual close button. This action will partially discharge the closing spring and also partially close the vacuum interrupter contacts.

CAUTION: DO NOT REMOVE TIE BAR (FIGURE 18, ITEM 1) UNLESS SPRING HAS BEEN REMOVED FROM THE BREAKER.

CAUTION: DO NOT ENERGIZE THE SECONDARY CONTROL CIRCUIT AT THIS TIME.

USE OF THE GAG TOOL SHOULD ONLY BE ATTEMPTED WHEN THE BREAKER IS OUT

7-4 Slow Closing

To manually slow close the breaker contacts, remove the top plate of mechanism. Install the closing spring gag, as described above. Put the manual charge handle on the manual charge lever and move the handle up and down. The breaker will be fully closed when the spring charge indicator shows "CHARGED"

CAUTION: WITH THE GAG TOOL INSTALLED, THE BREAKER CLOSED, AND OPENING SPRINGS CHARGED, THE BREAKER CAN BE TRIPPED AT FULL SPEED.

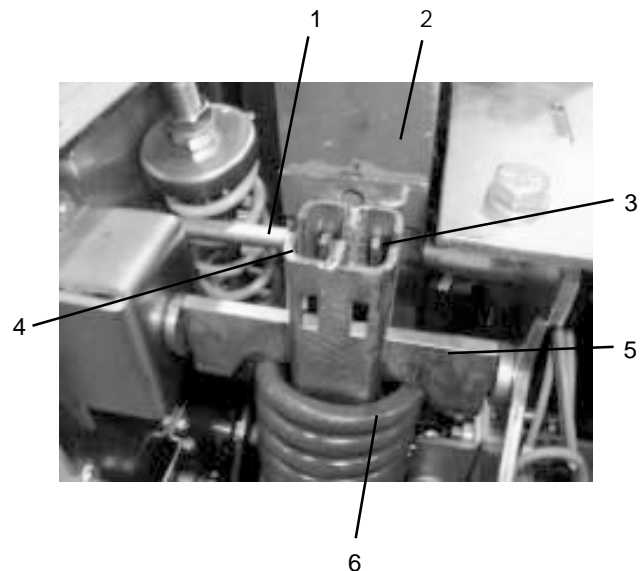

- | | |
|---------------------|------------------------|
| 1 Tie bar | 4 Closing spring guide |
| 2 Gag tool | 5 Spring pin |
| 3 Gag tool détentes | 6 Closing spring |

Figure 22. Closing spring with gag tool inserted

7-5 Gag Tool Removal

To remove the gag tool, the closing spring must be fully charged. If the spring charge indicator does not show "CHARGED" in the window, manually charge the spring until it does. Lift up and push down and away on the gag tool to clear the détentes on the gag tool from the slots in the closing spring guide. For safety, first close the breaker by depressing the manual "CLOSE" button and then depress the manual "TRIP" button. All stored energy is now removed from the breaker.

8-1 Primary Contact Erosion

The vacuum interrupter is a sealed unit and the contacts are not visible. The contacts are designed for 0.125" total wear. When 0.125" of wear has occurred, the vacuum interrupter must be replaced. Vacuum interrupters are typically good for 25 full rated interruptions before the 0.125" wear has been reached. Vacuum interrupters are also good for in excess of 10,000 no-load operations and 5,000 load operations. The mechanical seal system will develop a leak in the bellows before the contacts will reach 0.125" wear. See Chapter 9 for vacuum integrity test..

Each interrupter has been premeasured at the factory for the primary contact gap and this measurement has been recorded on the ceramic bottle. This measurement varies from phase to phase and from breaker to breaker but is approximately 4 inches. The actual measurement "A" is the distance from the bottom of the insulated operating rod to the bottom of the lower stainless steel interrupter support as shown in Figure 24. To determine contact wear repeat this measurement on each phase and subtract the measurement from the factory recorded measurement. If the difference is 0.125" or greater then the vacuum interrupter should be replaced. See Chapter 12.

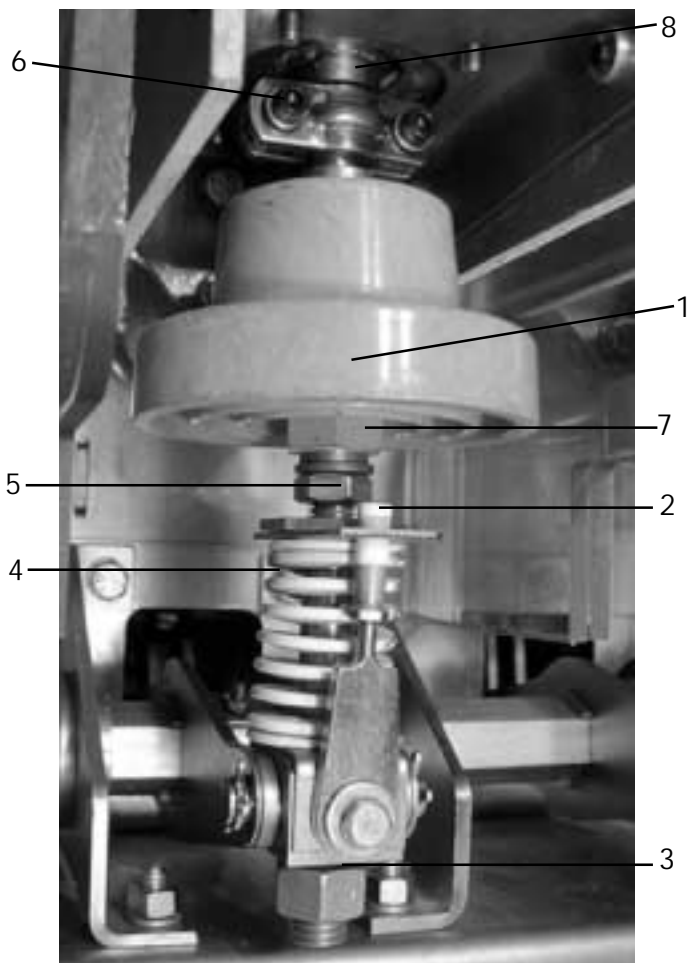

- 1 Operating Rod Insulator
- 2 Wipe Indicator
- 3 Wipe Gap
- 4 Wipe Spring
- 5 Lock Nut and Lock Washer
- 6 Coupling Clamps and Screws
- 7 Hexagon Projection
- 8 Interrupter Movable Contact Rod

Figure 23. Contact Erosion Indicator

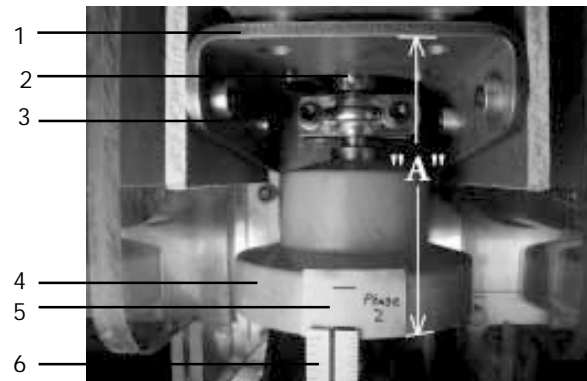

- 1. Lower Interrupter support
- 2. Moving contact rod
- 3. Coupling clamp
- 4. Insulated operating rod
- 5. Masking Tape
- 6. Reference block

Figure 24. Primary contact erosion measurement - rear view.

8-2 Spring Wipe Indicator

The wipe springs are preloaded to a length of 2.25 inches. When the breaker is closed, the secondary drive cranks will continue to move upwards after the primary contacts in the vacuum interrupter have been closed. This over travel is taken up by compressing the wipe springs. The over travel distance is pre-adjusted at the factory to be 0.125" minimum. The spring wipe can be verified by viewing the wipe indicator. (Figure 23, Item 2) The wipe indicator has four red lines that make up a total distance of 0.125". The wipe indicator was preset at the factory so that when the breaker is charged and closed all four red lines should be visible above the wipe plate.

With the breaker closed and charged and the closing spring gaged for safety (Chapter 7-3), verify that each phase has sufficient spring wipe. If more than two red lines are showing the breaker wipe is sufficient. The minimum wipe, 0.050", has been reached when the white space between the second and third line is no longer visible above the wipe plate. Adjustment is not required until wipe is 0.050 inch or less.

If adjustment is required see WIPE ADJUSTMENT in MECHANICAL ADJUSTMENTS Chapter 11-2.

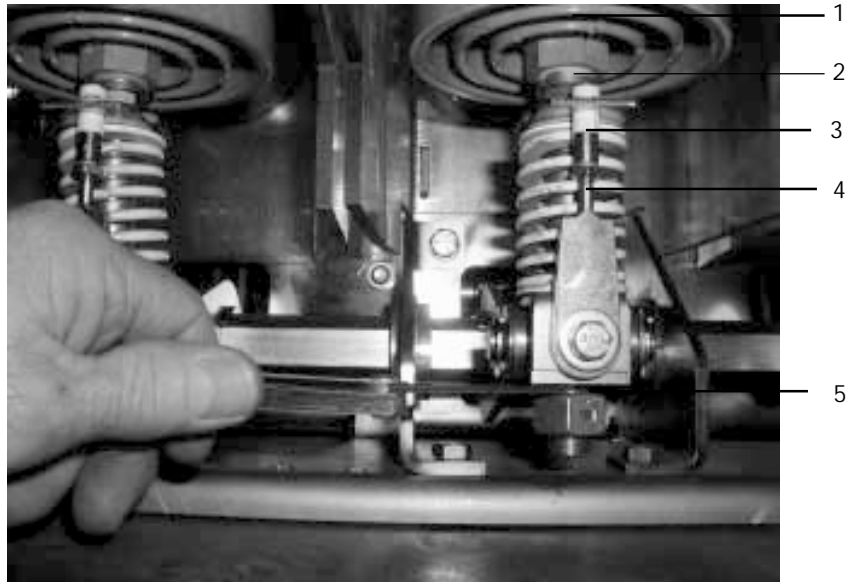

- | | |
|---------------------------|---------------------------------|
| 1 Operating rod insulator | 4 Wipe Indicator adjustment nut |
| 2 Operating rod nut | 5 Actual Wipe measurement |
| 3 Wipe indicator | |

Figure 25. Wipe indicator check and wipe measurement - rear view.

8-3 Contact Gap

The method of measuring the contact gap is as follows: First with the breaker in the open position, the closing springs charged, and the closing spring gag tool installed for safety (Chapter 7-3), apply a piece of masking tape to the surface of the operating rod insulator as shown in Figure 24. Using a reference block, make a mark on the tape near the top on all three poles. The reference block should be $6 \frac{23}{32}$ " long, if the breaker mechanism has been removed from the breaker truck, or X" if verifying the gap with the element installed in the truck. It is also advisable to put a reference mark on the tape to identify to which pole the tape is applied.

Remove the closing spring gag tool and close the breaker. Using the same procedure as above, re-mark the tape. This new mark will be near the bottom of the tape. Trip the breaker, remove the tapes and re-apply them to a flat surface. Measure the distance between the two lines. A caliper will give an accurate reading of the contact gap.

Dimension B: The gaps must be between 0.480"

and 0.600" for all three phases.

A properly adjusted breaker will generally have less gap and wipe on the center pole than on the outside poles. Due to the fact that the outer phases are directly driven by the secondary drive cranks by the primary cross shaft and the center phase is driven by the secondary drive cranks by the secondary cross shaft, the center phase tends to lag the outer phase during opening and closing. See Chapter 5-4 and 5-5 for a thorough description on opening and closing. It is important that the three phases do not open or close more than two milliseconds apart from each other. In general the center phase will need a gap of 0.020" less than the outer phases to prevent any phase stagger. If the center phase measures 0.550" nominally then the outer phase should be approximately 0.570" .

9-1 Electrical Operation

Electrical checking consists of electrical breaker operation primary and secondary wiring high-potential testing (if required), primary circuit resistance (if required), PowerVac interrupter high-potential testing, and insulation resistance to ground.

To check the electrical operation with the breaker removed from the cubicle, attach a secondary test coupler to the circuit breaker connector and the other end to the secondary coupler mounted in the cubicle. Check the control voltage on the nameplate and close and open the breaker several times.

CAUTION: REPEATED OPERATIONS AT A RATE EXCEEDING TWO PER MINUTE MAY CAUSE CHARGING MOTOR OVERHEATING AND FAILURE.

Leave the circuit breaker in an open and spring discharged condition after checks are complete and before inserting the circuit breaker into a metal-clad unit. Reinstall the front cover if it has been removed.

9-2 High-Potential Test

If hi-potential tests to check the integrity of the insulation are required, the AC hi-potential test described below is strongly recommended. DC high-potential testing is not recommended. The following procedure must be adhered to.

CAUTION: IF DC HIGH-POTENTIAL TESTING IS REQUIRED, THE DC HIGH POTENTIAL MACHINE MUST NOT PRODUCE PEAK VOLTAGES EXCEEDING 50 KV.

NOTE: ALWAYS RECHECK WITH AN AC TEST SET, IF INITIAL RESULTS ARE QUESTIONABLE.

Primary Circuit

The breaker should be AC hi-potted in the closed breaker mode to verify the insulation system. An AC hi-pot machine capable of producing the test voltages shown below may be used to hi-pot the breaker phase to phase and phase to ground.

BREAKER VOLTAGE	TEST VOLTAGE
4.16 kV	14 kV

CAUTION: DISCONNECT THE SURGE SUPPRESSORS BEFORE HI-POTTING THE CIRCUIT BREAKER.

The machine should be connected with its output potential at zero and the voltage increased at 500 vps to the test voltage and that voltage maintained for 60 seconds. The voltage should then be returned to zero and the hi-pot machine removed from the circuit. Do not exceed the test voltage indicated for the applicable breaker voltage rating.

If the test should experience a failure, STOP, turn off the test set and discharge the breaker circuit.

1. Check the test setup and leads for connection errors.
2. Wipe down the breaker to remove any moisture, dust and contamination.
3. Retest the breaker at the proper test voltage.

Secondary Circuit

Prior to hi-potting the breaker secondary circuit, disconnect the motor leads and thread a wire connecting all secondary coupler pins. Connect the hi-pot machine from this wire to ground. Increase the voltage to 1125 volts (rms) 60 Hz and maintain for 60 seconds. Reduce the voltage to zero and remove the hi-pot machine connections from the circuit. Remove the wire connecting the secondary coupler pins and reconnect the motor leads.

9-3 Primary Circuit Resistance

A resistance check of the primary circuit may be made with the breaker closed. Use a low resistance measuring instrument which measures micro-ohms. The 100 ampere reading should be less than 40 micro-ohms when connected.

9-4 Vacuum Interrupter Integrity Test

NOTE: USE OF A DC HI-POT IS NOT RECOMMENDED, BUT CAN BE USED FOR QUICK FIELD CHECKS ONLY. ALWAYS RECHECK WITH AN AC TESTER IF INITIAL RESULTS ARE QUESTIONABLE. PRIOR TO PERFORMING ANY VACUUM INTERRUPTER INTEGRITY TEST, THE OUTSIDE (EXTERNAL SURFACE) OF THE VACUUM INTERRUPTERS SHOULD BE WIPED CLEAN OF ANY CONTAMINATES WITH A NON-LINTING CLOTH OR INDUSTRIAL TYPE WIPER. THIS IS CRITICAL: THE ENTIRE EXTERNAL SURFACE IS TO BE COMPLETELY FREE OF ALL DIRT, DEBRIS, DUST, OIL, ETC.

CAUTION: X-RADIATION WILL BE PRODUCED IF AN ABNORMALLY HIGH VOLTAGE IS APPLIED ACROSS A PAIR OF ELECTRODES IN A VACUUM. X-RADIATION WILL INCREASE AS VOLTAGE INCREASES AND/OR AS CONTACT SEPARATION DECREASES. ONLY TEST A CORRECTLY-ADJUSTED CIRCUIT BREAKER.

DURING A HIGH-POTENTIAL OR A VACUUM INTEGRITY TEST, ANY X-RADIATION WHICH MAY BE PRODUCED WILL NOT BE HAZARDOUS AT A DISTANCE SAFE FOR HIGH-POTENTIAL TESTING, IF THE TEST IS CONDUCTED AT THE RECOMMENDED VOLTAGE AND WITH THE NORMAL OPEN CIRCUIT BREAKER GAP.

DO NOT APPLY VOLTAGE THAT IS HIGHER THAN THE RECOMMENDED VALUE OR USE CONTACT SEPARATION THAT IS LESS THAN THE RECOMMENDED OPEN-POSITION BREAKER CONTACT GAP.

This test of the vacuum interrupter will determine its internal dielectric condition and vacuum integrity.

CAUTION: DISCONNECT THE SURGE SUPPRESSORS BEFORE HI-POTTING THE CIRCUIT BREAKER AND VACUUM INTERRUPTERS.

The vacuum integrity test is performed using an AC hi-potential tester. A vacuum integrity test of the interrupter is required to insure that no loss of vacuum has occurred.

With the breaker open, individually check each interrupter by connecting the hi-pot machine "Hot" lead to the primary bushing and the ground lead to the load side bushing. If the machine has a center point ground, the connections can be made either way.

For the Vacuum Integrity Test, Apply 27 kV (rms) 60 Hz at 500 vps and hold for 10 seconds. If no breakdown occurs, the interrupter is in acceptable condition. After the hi-potential voltage is removed, discharge any electrical charge that may be present through the internal ground of the test machine or by a grounded cable to one of the phase bushings.

If a failure of a vacuum bottle should occur during the integrity test, the test procedure should be reviewed and the pole piece cleaned.

GE failure rate for vacuum bottles is 0.0007 per field unit.

1. Note the voltage level at failure on the first test, and retest the phase pole piece. If the pole piece passes re-test, the vacuum bottle is acceptable. STOP.
2. If the test fails again, but at a higher-voltage level than was observed in the first test, clean the pole piece and retest.
3. If a failure of the integrity test occurs a third time, consider the vacuum bottle to have lost vacuum and replace the complete pole piece as described under Repair of Interrupter Assembly, Chapter 12.

Although a AC high-potential test is recommended for checking the vacuum integrity, a DC high potential test can also be conducted on the vacuum interrupters at 40 kV and held for 10 seconds with the restrictions noted as follows.

1. No attempt should be made to compare the one vacuum interrupter with another, nor to correlate the condition of any interrupter to low values of DC leakage current. There is no significant correlation.

2. After the high-potential voltage is removed, discharge any electrical charge that may be retained.

CAUTION: MANY DC HIGH-POTENTIAL MACHINES ARE HALF-WAVE RECTIFIERS. THIS TYPE OF HI-POT TESTER MUST NOT BE USED TO TEST VACUUM INTERRUPTERS. THE CAPACITANCE OF THE POWERVAC BOTTLES IS VERY LOW AND THE LEAKAGE IN THE RECTIFIER AND ITS DC VOLTAGE MEASURING EQUIPMENT IS SUCH THAT THE PULSE FROM THE HALF-WAVE RECTIFIER MAY BE IN THE NEIGHBORHOOD OF 120 KV WHEN THE METER IS ACTUALLY READING 40 KV. IN THIS CASE, SOME PERFECTLY GOOD BOTTLES CAN SHOW A RELATIVELY HIGH LEAKAGE CURRENT SINCE IT IS THE PEAK VOLTAGE OF 120 KV THAT IS PRODUCING ERRONEOUS BOTTLE LEAKAGE CURRENT. IN ADDITION, ABNORMAL X-RADIATION WILL BE PRODUCED.

The following is a list of acceptable hi-potential machines.

AC machines:	Hipotronics	Model 7BT 60A
	Hipotronics	Model 60HVT
	Biddle	Cat. 222060
	Phoenix	Model 7BT 60A
DC machines:	Hipotronics	Model 860PL
	Hipotronics	Model 880PL

9-5 Insulation Tests

The primary circuit insulation on the breaker may be checked phase to phase and phase to ground using a 2500 Volt or other suitable megohmmeter.

CAUTION: DISCONNECT THE SURGE SUPPRESSORS BEFORE HI-POTTING THE CIRCUIT BREAKER.

Since definite limits cannot be given for satisfactory insulation values, a record should be kept of the megohmmeter readings as well as temperature and humidity readings. This record should be used to detect any weakening of the insulation from one check period to the next. Generally, readings should equal or exceed 10,000 megohms.

To measure the breaker secondary circuit insulation resistance, with a megohmmeter disconnect the motor leads and thread a wire connecting together all secondary coupler pins. The measurement is made by connecting a 500 Volt megohmmeter from the wire to ground.

10-1 General

PowerVac® 5kV VL circuit breakers have been designed to be as maintenance-free as practicable. They include features such as sealed vacuum interrupters and long-life synthetic greases which contribute to many years of trouble-free performance with a minimum amount of maintenance.

If maintenance on the PowerVac® VL breaker is being performed to an extended schedule such as a 5-year or 10-year program, the vacuum interrupter integrity test should be performed if the breaker is removed for reasons other than scheduled breaker maintenance, and it has been more than one year since the last vacuum integrity test.

Both long and short term maintenance of all electrical equipment is essential for reliability and safety. Maintenance programs **MUST** be customized to the specific application, well planned, and carried out consistent with both industry experience and manufacturer's recommendations. The local environment must always be considered in such programs, including such variables as ambient temperatures, extreme moisture, number of operations, corrosive atmosphere or major insect problems and any other unusual or abusive condition of the application.

One of the critical service activities, sometimes neglected, involves the servicing and calibration of various relay, protection, and control devices. These devices monitor conditions in the primary and secondary circuits, sometimes initiating emergency corrective action such as opening or closing circuit breakers. In view of the vital role of these devices, it is important that a periodic test program be followed. As was outlined above, it is recognized that the interval between periodic checks will vary depending upon environment, the type of device and the user's experience. It is the General Electric recommendation that, until the user has accumulated enough experience to select a test interval better suited to his individual requirements, all significant relay calibrations should be checked at an interval of one to two years.

To accomplish this, protective relays can be adequately tested using field test sets. Specific calibration instructions on particular devices typically are provided by supplied instruction books.

Instruction books supplied by manufacturers address components that would normally require service or maintenance during the useful life of the equipment. However, they can not include every possible part that could require attention, particularly over a very long service period or under adverse environments. Maintenance personnel must be alert to deterioration of any part of the supplied switchgear, taking actions, as necessary, to restore it to serviceable status.

Industry publications of recommended maintenance practices such as ANSI/NFPA 70B, Electrical Equipment Maintenance, should be carefully studied and applied in each user's formation of a planned maintenance program.

Some users may require additional assistance from GE in the planning and performance of maintenance. The local GE office can be contacted to either undertake maintenance or to provide technical assistance, including the latest equipment publications.

The performance and safety of this equipment may be compromised by the modification of supplied parts or their replacement by non-identical substitutes. All such design changes should be qualified by GE factory engineering.

The user should methodically keep written maintenance records as an aid in future service planning and equipment reliability improvement. Unusual experiences should be promptly communicated to GE.

PowerVac® Interrupter

The PowerVac® Interrupter used in this breaker is a reliable, clean interrupting element. Since the contacts are contained in a vacuum chamber, they remain clean and require no maintenance at any time. The metallic vapors eroded from the contact surfaces during high current interruption remain in the chamber and are deposited on metal shields thus insuring a high dielectric value of the vacuum and the walls of the interrupter.

Trouble Reporting

Although all reputable manufacturers design their products to perform satisfactorily with a minimum of problems, the IEEE Switchgear Committee, an organization of both users and manufacturers, recognized the need for a common trouble reporting format. A reproducible copy of this form is included on pages 66 and 67 of this book and is recommended for use with any manufacturer's circuit breakers.

Any major observed problems should be documented. Forward the completed user report forms to GE Resolution at West Burlington, Iowa.

The intent is for each maintenance organization to keep specific problem files with this information documented. If the problem is serious or repetitive, a summary should be sent to the appropriate manufacturer for action. The level of detail included on the form is considered very desirable so that the manufacturer's investigator may more thoroughly understand and solve the reported problem.

10-2 Service Conditions

The frequency of required maintenance depends on the severity of the service conditions of the switchgear application. If the service conditions are mild, the interval between maintenance operations may be extended to 10 years or 10,000 no load operations or 5000 normal load switching operations.

Mild service conditions are defined as an environment in which the switchgear is protected from the deleterious effects of conditions such as:

- Salt spray.
- Changes in temperature that produce dust conductive/or abrasive and condensation.
- Damaging chemicals and fumes.
- Vibration or mechanical shock.
- High relative humidity (90%).
- Temperature extremes (below -30° C or above +40° C).

WARNING: BEFORE ANY MAINTENANCE WORK IS PERFORMED, MAKE CERTAIN THAT ALL CONTROL CIRCUITS ARE DE-ENERGIZED AND THAT THE BREAKER IS REMOVED FROM THE METALCLAD UNIT. DO NOT WORK ON THE BREAKER OR MECHANISM WHILE IT IS IN THE CLOSED POSITION WITHOUT TAKING PRECAUTIONS TO PREVENT ACCIDENTAL TRIPPING. DO NOT WORK ON THE BREAKER WHILE THE CLOSING SPRING IS CHARGED UNLESS IT IS SECURED IN THAT POSITION BY THE CLOSING-SPRING GAG.

10-3 Fault Interruptions

The erosion rate of the primary contacts in the vacuum interrupters is very low for no-load and normal load switching operations. However, fault current interruptions at or near the breaker rating may result in appreciable contact erosion. With frequent fault interruptions, it is necessary to perform maintenance based on the number of interruptions. After each 20 full fault interruptions the following should be performed:

1. Contact erosion check.
2. Wipe and gap check.
3. Vacuum interrupter integrity test.

10-4 Contact Erosion

Refer to Chapter 8-1 for contact erosion and contact gap measurements. When erosion reaches 1/8 inch, the interrupter should be replaced.

10-5 Transfer Finger Wear

With the breaker open, examine the moving contact rod projecting below the transfer fingers (Figure 23, Item 8). Wipe off the lubricant in order to see the metal surface condition. The finger locations should present a burnished silver contact surface without copper appearance. If copper is visible at more than one location per pole or the silver plating is torn, the interrupter assembly should be replaced. After inspection, re-lubricate with grease, part # 0282A2048P009 (Mobil 28 red grease).

10-6 Mechanism

Check all items covered in INSTALLATION Chapter 4 and readjust or tighten hardware as required. Lubricate as recommended under LUBRICATION.

10-7 Primary Insulation Parts

Using dry, non-linting cloth or industrial-type wipers, clean accessible insulation surfaces on the interrupter supports and operating rod insulators. In service locations, where contamination is heavy or external flashovers have occurred, or occurrence is noted during interrupter high-potential testing, remove the interrupter assemblies and clean the inside surfaces of the interrupter supports and the outer insulation surfaces of the PowerVac interrupters. Follow the procedure in REPAIR AND REPLACEMENT, Chapter 12.

Be sure to discharge the interrupter before removing the interrupter assemblies. Removal and re-assembly of complete interrupter assemblies is recommended and adjustment is not normally required due to the design of the interrupter operating rod insulator connection. The interrupter assemblies should be returned to the same location from which they were removed.

Replacement of individual vacuum bottles is not recommended. Therefore, vacuum bottles are not supplied as a replacement part.

10-8 Lubrication

Proper lubrication is important for maintaining reliable circuit breaker performance. The ML-19 mechanism uses bearings which have a synthetic lining in some locations. These bearings do not require lubrication to maintain low friction, but lubrication does not harm them and oiling lightly is recommended. Sleeve bearings are used in some linkage locations and needle or roller bearings are used for low friction on the trip shaft and close shaft.

Bearings are lubricated during factory assembly with grease and oil, but all lubricants have a tendency to deteriorate with age. Providing a fresh lubricant supply at periodic intervals is essential to proper breaker operation, especially where frequent operation may have forced lubricant out of the bearing surfaces. Apply a few drops of light synthetic machine oil such as Mobil 1 at each bearing. Apply a coat of 0282A2048P009 grease on the four corners of the closing spring guide where it enters inside the spring. Metal-to-metal contact surfaces should be cleaned and lubricated with 0282A2048P009 grease to provide cleanliness and prevent oxidation.

Electrical primary contact surfaces also require periodic lubrication to inhibit oxidation and minimize friction. At each inspection and maintenance interval, do the following:

1. Wipe clean and coat lightly with 0282A2048P009 grease all silvered primary contact surfaces such as the movable contact rod of the interrupter and the primary disconnect fingers.
2. Clean and coat lightly with 0282A2048P009 grease the pins of the secondary coupler.

10-9 Recommended Maintenance

The following operations should be performed at each maintenance check:

1. Perform a visual inspection of the breaker. Check for loose or damaged parts.
2. Perform a slow closing operation described under MECHANICAL CHECKING AND SLOW CLOSING.
3. Check the erosion indicator and the wipe and gap as described under DIMENSIONAL CHECKS.
4. Perform the vacuum interrupter integrity test as described under ELECTRICAL CHECKS.
5. Lubricate the breaker operating mechanism as described under LUBRICATION.
6. Check the electrical operation of the breaker using the portable test cabinet.

CAUTION: REPEATED OPERATIONS AT A RATE EXCEEDING TWO PER MINUTE MAY CAUSE CHARGING MOTOR OVERHEATING AND SUBSEQUENT MOTOR FAILURE.

7. Examine the movable contact rod as described in Chapter 10-5.
8. If desired, perform the additional tests (Megger, Primary and Secondary High Potential, and Primary Circuit Resistance). See ELECTRICAL CHECKS.

10-10 Breaker Timing & Speed Check

Timing and speed checks are optional and also depend on the level of maintenance performed. Generally these tests are not required for normal maintenance. If a new mechanism has been installed or extensive repair, replacement or major disassembly has been performed, it is recommended that these tests be performed.

To determine contact velocity, a travel transducer and oscillograph are required. Optional travel transducer and linkage system can be obtained by contacting your local GE Sales Office by ordering part number 0144D1238G001. The travel transducer apparatus can typically be installed as shown in Figure 28. A typical travel trace and interpretation are shown in Figure 26.

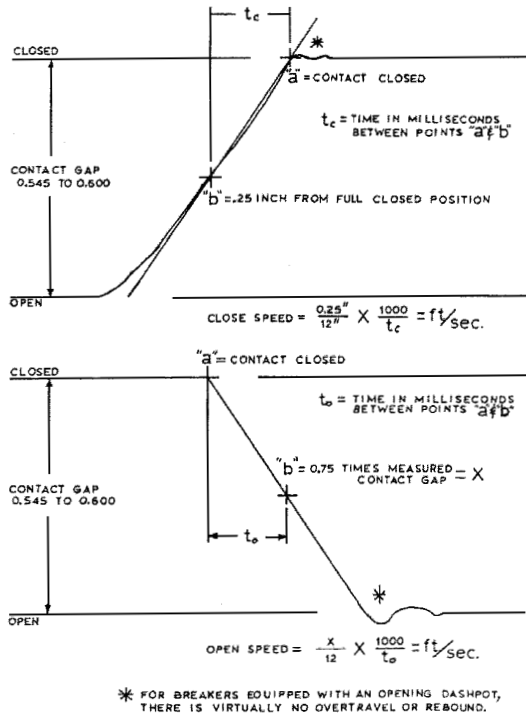

Figure 26. Sample Operating Speed Graphs

Timing may be checked by monitoring control circuit voltage and using no more than six volts DC and one ampere through the vacuum interrupter contact to indicate closed or open condition. Typical time ranges vary with coil voltage, but nominal values are:

Initiation of trip signal to contact parting

32-45 milli-seconds
2 milli-seconds maximum pole spread

Initiation of close signal to contact closing

35-75 milli-seconds
2 milli-seconds maximum pole spread.

Trip-free operation may be checked by applying a simultaneous close and trip signal, and a minimum reclose operation may be checked by tripping a charged breaker open while maintaining a close signal.

Instantaneous reclose time 85-150 milliseconds.

*Time from application of trip signal until breaker contacts reclose.

The opening speed is modified by moving the speed adjusting nuts on the opening spring assemblies. A change in the opening speed affects the closing speed Reference Figure 27.

The operating speeds for 5 cycle breakers with the MOC are as follows:

Operation	Feet Per Second
Open	6.5 normal, 4.5 minimum
Close	2.6 nominal, 4.2 maximum

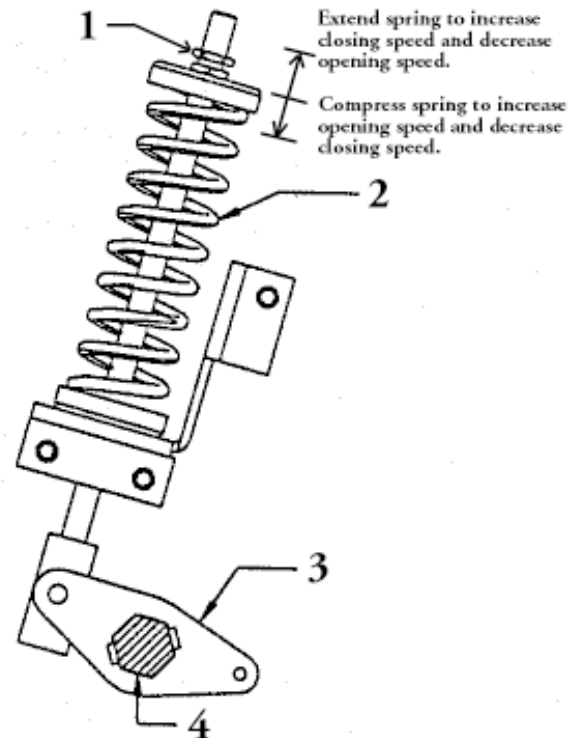

Figure 27. Opening Speed Adjustment

1. Lock Nuts
2. Opening Spring
3. Outer Bell Crank
4. Primary Cross Shaft



Figure 28. Travel Transducer Installation (Part # 0144D1238G001)

- | | |
|--------------------|---------------------|
| 1. Clamp | 3. Transducer |
| 2. Connecting Link | 4. Mounting Bracker |

11-1 General

The ML-19 VL Mechanism has been designed for extended intervals between maintenance. In most cases only the wipe and gap adjustments will require re-setting throughout the life of the circuit breaker.

11-2 Wipe Adjustment

Wipe is the additional compression of a pre-loaded spring, used to apply force to the vacuum interrupter contacts and to provide opening kick-off force. Always adjust the contact wipe before adjusting the gap.

An indicator is provided on the wipe spring assembly with graduations given in 0.032 inch on which the wipe is indicated directly. Reference Figure 29.

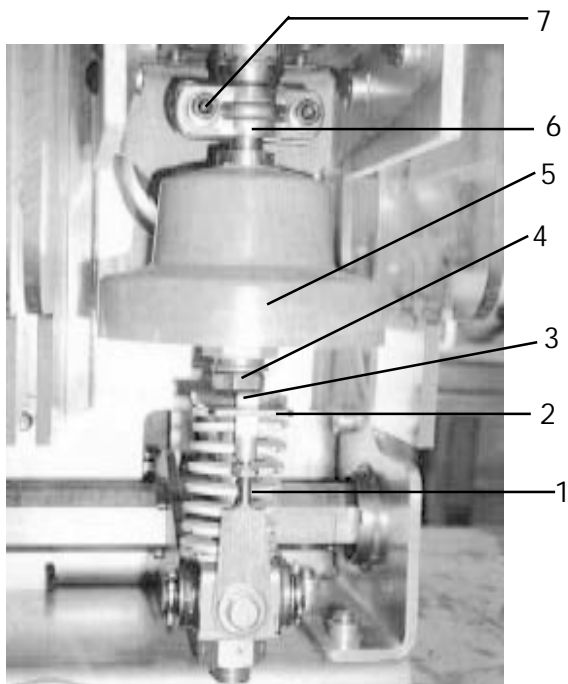

- 1 Wipe Spring
- 2 Wipe Plate
- 3 Wipe Indicator
- 4 Locknut
- 5 Operating Rod
- 6 Coupling Clamp
- 7 Coupling Clamp Screws

Figure 29. Wipe Insulator

Improved accuracy of wipe measurement may be obtained by using a feeler gauge between the top of the wipe spring (5/8) nut and bottom of the spring block. The difference in readings on each pole with the breaker closed and open is the contact wipe. Adjustment is not required if the wipe is more than 0.075 inch. After adjustment the wipe should be 0.15-0.18 inch.

To adjust the primary contact wipe, close the breaker and proceed as follows:

1. Loosen, but do not remove, the two cap screws (Figure 29, Item 7) holding the interrupter clamp.
2. Check that the interrupter clamp is loose. A light prying at the clamp half junction may be required to loosen the wedging action of the clamp.
3. Hold the hexagon projection (Figure 29, Item 4) at the bottom of the operating rod insulator (1 inch wrench) and loosen the adjacent locknut (Figure 29, Item 4), with (3/4 inch wrench). Adjust by rotating the operating rod insulator. The thread is 1/2-13 and each turn will give about 0.078 inch change in primary wipe. Screw the operating rod insulator toward the interrupter to increase wipe.
4. After setting the contact wipe on each phase, torque the operating rod locknut (Figure 28, Item 5) to 40-50 foot pounds while holding the hex projection (8) to prevent the operating rod insulator (5) from turning. Tighten the clamp screws (7) to 8-10 foot pounds and trip the breaker open. This procedure prevents accidental twisting of the interrupter's operating rod by loading the contacts with the wipe springs and forcing relative rotation to occur at the clamp interface. After adjustment, re-measure the wipe dimensions (Figure 25). If the wipe settings are within the required limits, this indicates there is an adequate contact closing relationship between the poles.

11-3 Contact Gap Adjustment

The gap adjustment refers to the separation, or gap, between the primary contacts within the vacuum interrupter. Before attempting to measure or set the gap adjustment, verify that the wipe settings are within acceptable limits. Any change of the wipe settings will affect the gap settings.

1. With the breaker in the open position and the closing spring discharged, the buffer arm should be stopped against the buffer. Pressing the stem into the buffer.
2. To verify contact gap dimensions, reference Figure 31.

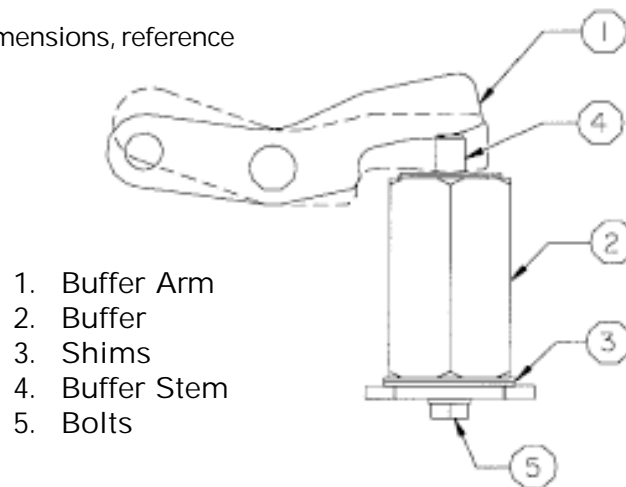

1. Buffer Arm
2. Buffer
3. Shims
4. Buffer Stem
5. Bolts

Figure 30. Contact Gap Adjustment—Opening Buffer

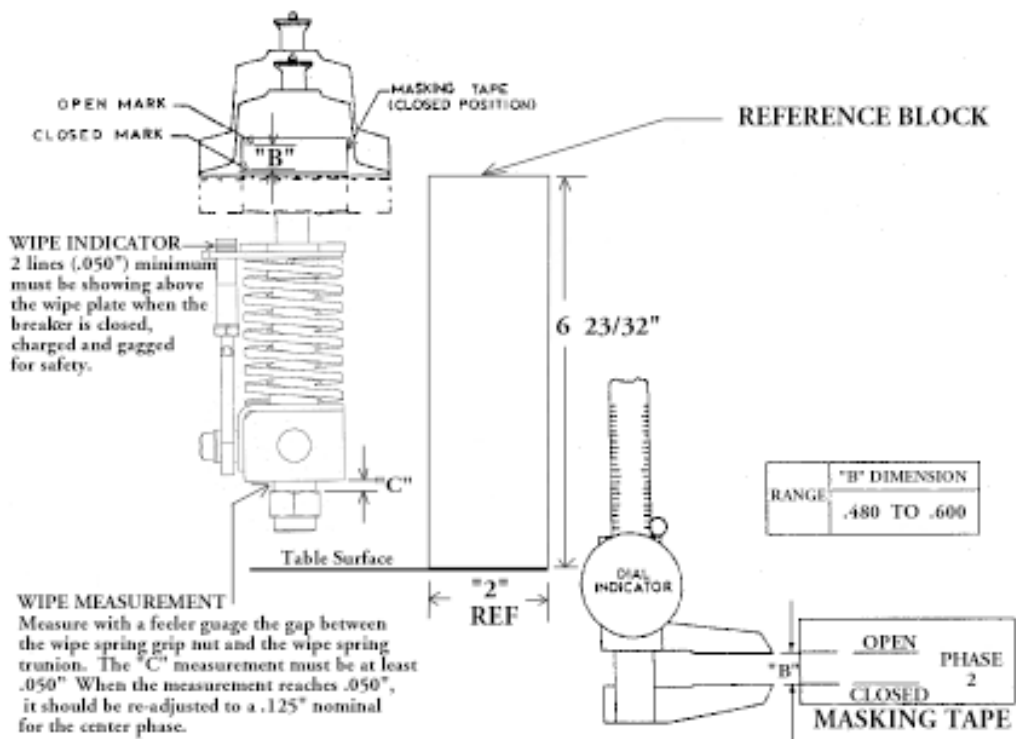

Figure 31. Contact Gap measurement, wipe indicator check and wipe measurement

11-4 Trip Coil Plunger Gap

To adjust the trip coil plunger gap (Figure 32), lift locktab (item 6) away from adjusting nut (item 5). Turn adjusting nut until actuator arm makes contact with trip lever (item 8) while maintaining dimension T. Bend locktab to secure adjusting nut.

The trip coil plunger gap is shown in Figure 32. With the closing spring removed, position the closing camshaft for that the latch roller is in contact with close latch. Ensure that the close roller (Figure 32) is reset and in contact with the close cam.

Depress the trip plunger until it contacts the trip release lever arm. Set the gap between the under side of the trip plunger mushroom head (Figure 32, Item 1 and Figure 34), and the top of the trip coil housing (Figure 32, Item 2) to 0.375.

Allow the trip plunger to fully reset and loosen the lover collar (Figure 32, Item 4) and push it upwards to remove all the free play in the positive interlock trip release linkage and tighten the set screws.

Measure the angle the positive interlock lever moves until the interlock trip release linkage (Figure 32, Item 7) causes contact with the trip release lever arm (Figure 32, Item 8); it is to be 4° or less.

Continue rotating the positive interlock lever until it reaches the hard stop position and observe that the trip release lever arm has rotated about 0.125.

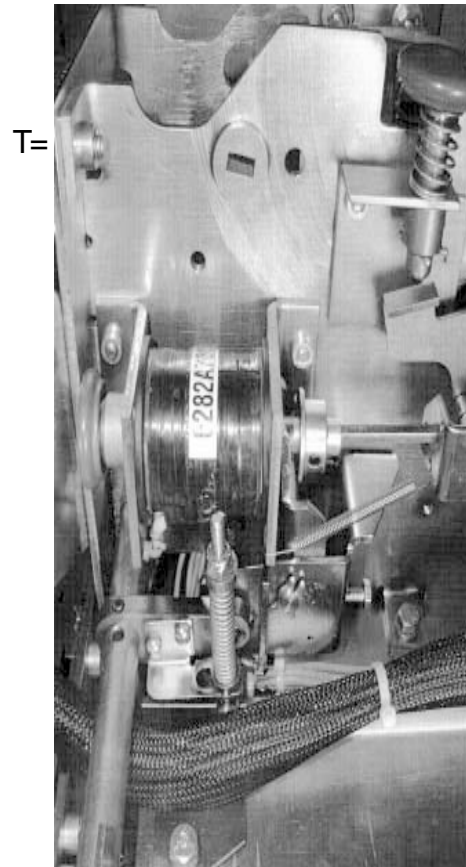

- | | |
|--------------------------|----------------|
| 1 Plunger base | 6 Locking clip |
| 2 Trip coil assembly | 7 Trip pin |
| 3 Positive interlock cam | 8 Trip lever |
| 4 Collar & set screw | 9 Actuator arm |
| 5 Adjusting nut | |

Figure 32. Trip coil gap adjustment



Figure 33. Trip coil button with gage

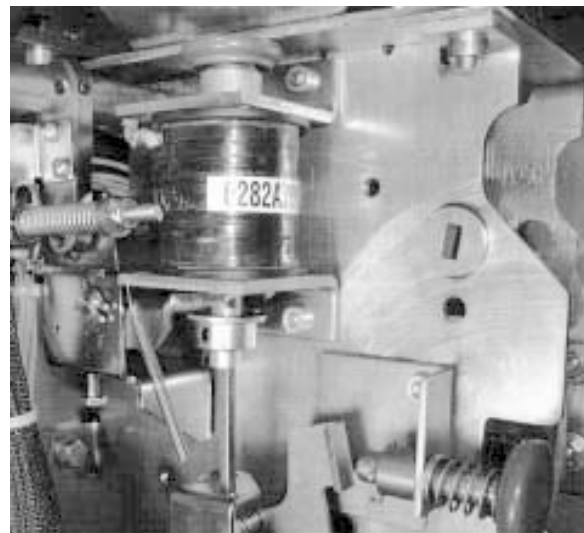

Figure 34. Trip coil assembly

11-5 Close Coil Plunger Adjustment

To adjust the close coil plunger gap (Figure 36)

The closing system is shown in Figure 35. With the closing spring discharged, operate the plunger to make certain that the plunger moves freely over its full stroke in the coil. To check the closing coil plunger gap the breaker should be open and the closing spring charged and gagged.

Adjusting plate (Figure 35 Item 10) is spring loaded against the pivot for the arm-this set the close coil actuating arm (Figure 34 Item 1). The collar and washer (Figure 35 Item 4 & Item 5) are assembled to the close plunger (Figure 36 Item 3) to the dimension indicated (.375"). This is the initial adjustment.

Measure the gap between the close plunger top clevis (Figure 36, Item 7) and the close coil housing (Figure 36, Item 1) when the attached lever is depressed and contacts the close release lever. (Varies from 0.375 - 0.560)

Release the plunger and set the plunger collar (Figure 36, Item 4) so that the close plunger clevis is at the previously measured gap plus 0.25.

Rotate the positive interlock lever until it reaches 18°, set the close plunger clevis gap to the close housing to **0.032 - 0.094 by adjusting the length of the vertical link** descending from the positive interlock shaft.

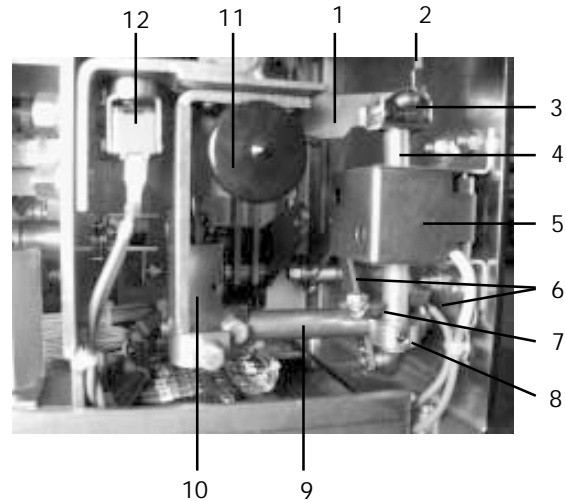

- | | |
|------------------------------|--------------------------------|
| 1 Close latch actuator | 7 Manual close arm |
| 2 Close return spring | 8 Adjusting collar & set screw |
| 3 Close plunger clevis | 9 Manual actuating shaft |
| 4 Close plunger | 10 Adjusting plate |
| 5 Close coil | 11 Manual close button |
| 6 Positive interlock linkage | 12 CLMS (switch) |

Figure 35. Close coil assembly -front view

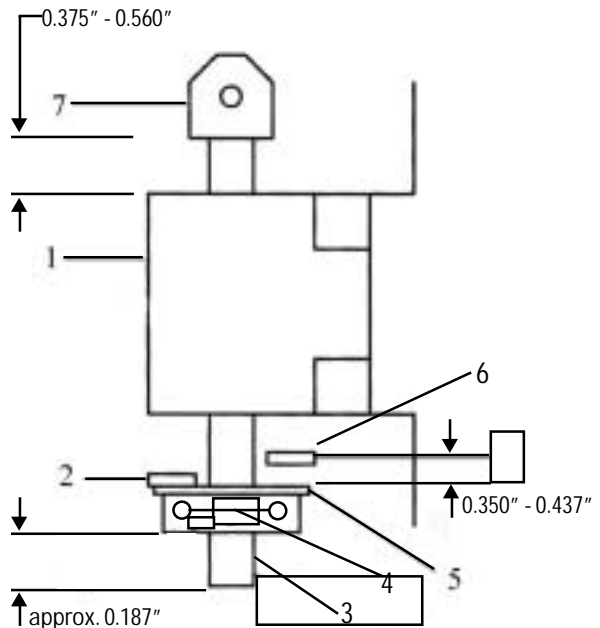

- | | |
|--------------------|--------------------------|
| 1 Close coil | 4 Collar & set screws |
| 2 Manual close arm | 5 Washer |
| 3 Close plunger | 6 Positive interlock arm |
| | 7 Close Plunger Clevis |

Figure 36. Close coil gap adjustment - front view

11-6 Control Switch Adjustment

The breaker is to be in the open position with the opening and closing springs discharged. This results in the control switch plungers being in the depressed position. Four sets of switches are to be checked. On the LCS (Figure 37, Item 5) and stacked switches (SM/LS & CHG) (Figure 37) the plunger rod is to be recessed within the rear of the switch body. The recess should measure between 0 and 1/32 inch. This is a visual check.

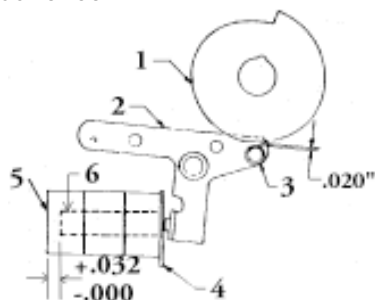

- | | |
|-------------------|---------------------------|
| 1 Charging crank | 4 Switch mounting bracket |
| 2 Switch actuator | 5 SM/LS & CHG switch |
| 3 Actuator roller | 6 Switch plunger |

Figure 37. SM/LS & CHG switch adjustment - left side view

The close latch monitor switch, CL/MS and the positive Interlock switch are a different type. They have a plunger that extends 1-3/16" from the switch frame. These normally open switches are actuated and closed when the breaker is not being operated. The switch closes when the switch plunger is depressed between 1/32" and 1/16" and remains closed throughout the remainder of the travel. The CL/MS switch should open when the close latch is being actuated and must be opened before the latch moves far enough to close the breaker. This is a visual check. The positive interlock switch should open as the positive interlock shaft rotates and must be opened before the positive interlock trips the breaker. This is a visual check. See Figure 38.

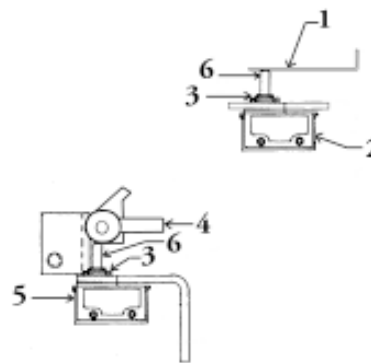

- | | |
|-------------------------------|------------------|
| 1 Positive Interlock actuator | 4 Close latch |
| 2 Positive Interlock switch | 5 CL/MS (switch) |
| 3 Switch adjustment nuts | 6 Switch plunger |

Figure 38. CL/MS and positive Interlock switch adjustment - right side view

11-7 Adjustment of MOC Switch

The Stationary Auxiliary Switch is an optional switch mounted in the switchgear cubicle. When the breaker has been elevated to the fully connected position, the switch will be actuated whenever the breaker is closed. The switch is actuated by the plunger interlock (plunger) mounted on the top of the breaker mechanism. The switch has a number of "a" contacts (closed when the breaker is closed and open when the breaker is open) and "b" contacts (open when the breaker is closed and closed when the breaker is open). The following paragraph defines the essential dimensions relating to the interfacing elements of the breaker and switchgear, to assure reliable performance.

The following elements are important factors which commonly affect the operation of the stationary auxiliary switch.

1. Plunger travel on the breaker.
2. The gap between the top of the plunger on the breaker and the bottom of the rod on the stationary auxiliary switch mechanism.
3. Variations between breakers in the distance from the underside of the lift rail and the top of the plunger.
4. Variations in the rotation requirements to "make" and "break" the stationary auxiliary switch contacts.
5. Condition of the plunger interlock components on the breaker.

6. Elevating mechanism limit switch consistency.
7. Breaker elevating mechanism positive stops.
8. Seismic events.

Some of these elements also affect the other important interfaces required for reliable operation of the equipment, such as:

1. Primary disconnect penetration.
2. Secondary coupler penetration.
3. The positive interlock mechanism.

A major goal in the design of switchgear has always been the interchangeability of breakers. GE Switchgear has been very successful in achieving that goal for many years. Analysis of instruction book adjustments, shop tolerances, and service advice letters issued in recent years, however, has demonstrated that tolerances in switchgear equipment installed and presently operating can result in situations where it is impossible to meet all adjustments or that an adjustment is brought into specification and it causes a problem with another interface.

With specific reference to the plunger/stationary auxiliary switch interface, the following adjustments should be verified.

Nominal breaker plunger travel is 1-1/16". Nominal auxiliary switch rod travel is 1-1/16". It is imperative that a gap is present between the top of the plunger and the bottom of the rod, when the breaker is in the fully connected position and the breaker is open.

To assure the most reliable switch operation, it is recommended that the plunger travel be measured for each breaker and recorded in maintenance records. It is further recommended that the auxiliary switch mechanism be adjusted, if necessary, to result in a gap that is in accordance with the table given in Figure 40.

This action may mean future adjusting when and if different breakers are interchanged. Reliable switch operation is critical and it may require limiting your interchangeability of breakers. At a minimum, the criticality requires adjustment verification when swapping breakers.

11-8 Positive Interlock

THIS INTERLOCK IS FACTORY-SET AND SHOULD NOT BE ROUTINELY ADJUSTED IN THE FIELD.



Figure 39. Positive Interlock

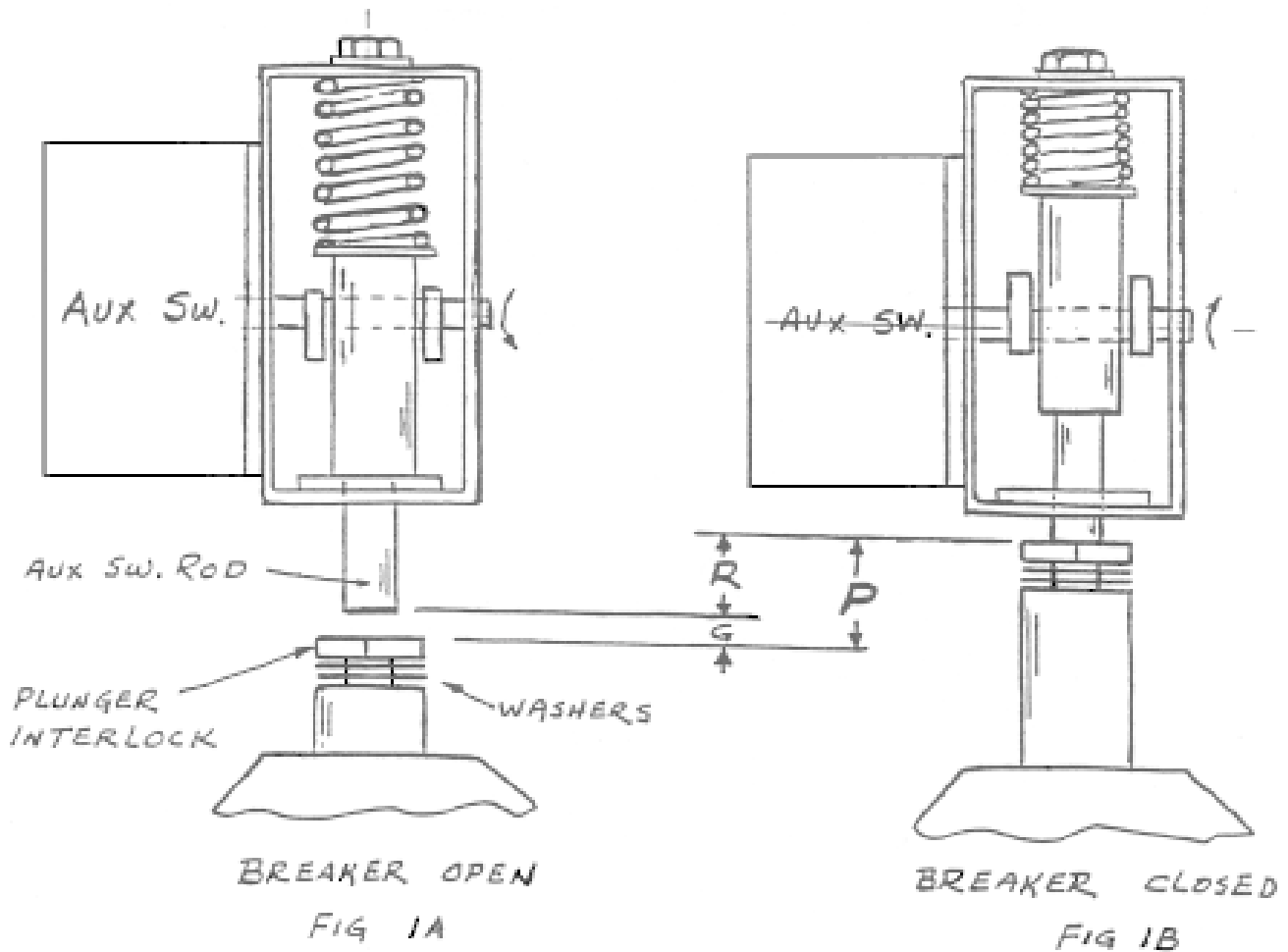

Adjustment of Plunger Interlock - Breaker raised to connect position. Gap adjustment as a function of breaker plunger travel to assure proper switch operation.

P	G		R	
Plunger Interlock Travel (To be measured)	Gap between top of plunger interlock and bottom of aux. switch rod		Resulting travel of the aux. switch rod	
	Min.	Max.	Min.	Max.
1-1/16	.001	1/16	1"	1-1/16

Figure 40. Adjustment of MOC Switch/Plunger Interlock

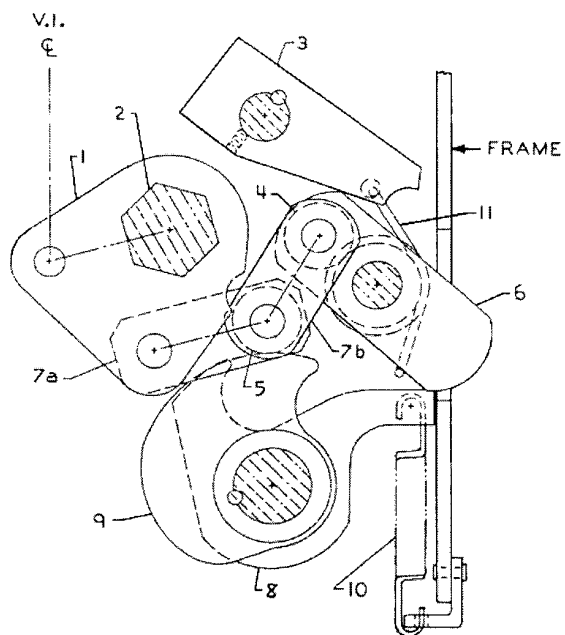

Breaker Open - Spring Discharged
Figure 41. Toggle Linkage Positions

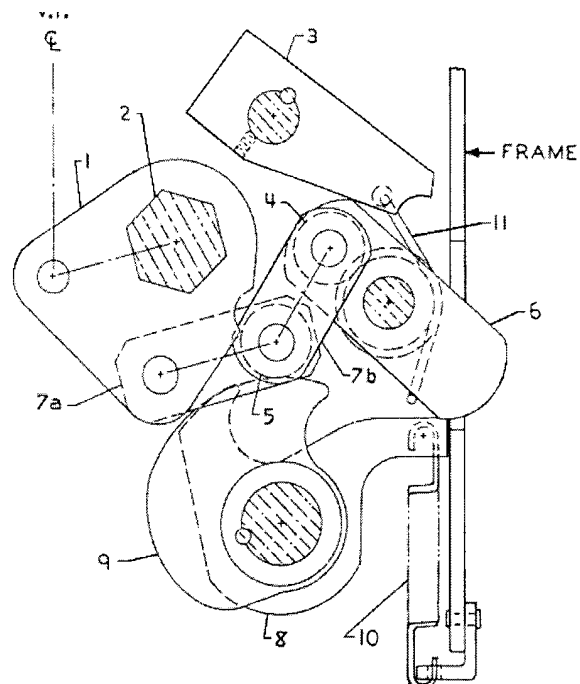

Breaker Closed - Spring Discharged
Figure 42. Toggle Linkage Positions (View from Right Side)

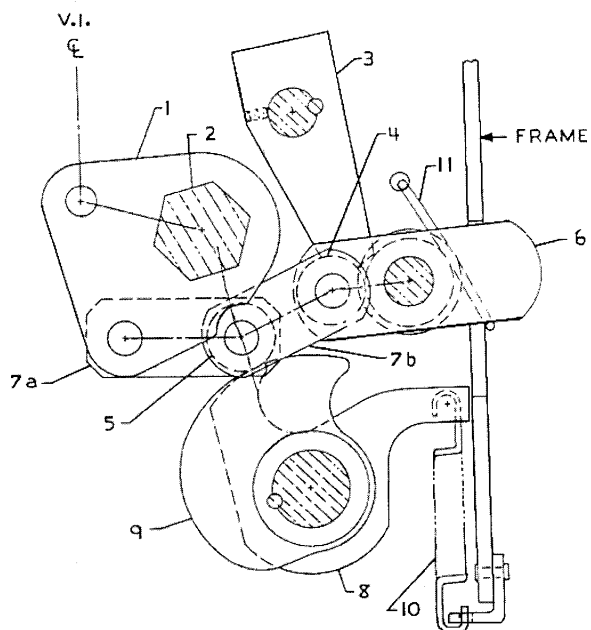

Breaker Open - Spring Charged
Figure 41A. Toggle Linkage Positions (View from Right Side)

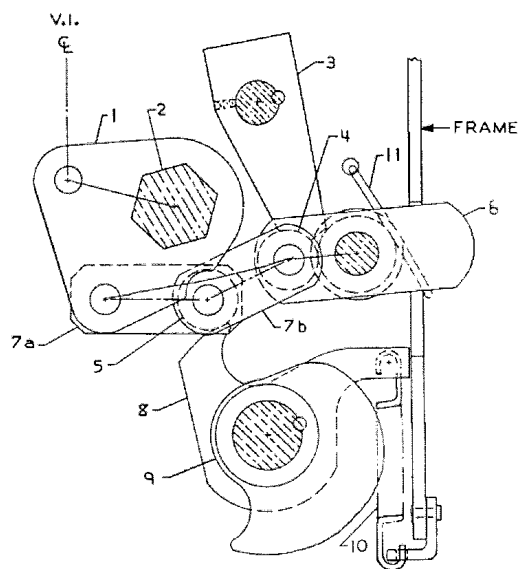

Breaker Closed - Spring Charged
Figure 42A. Toggle Linkage Positions (View from Right Side)

TABLE #1 MEASUREMENTS

ITEM	BREAKER	CLOSING SPRING	OPENING SPRING	MEASUREMENT
Contact Wipe	Open Closed	Charged Charged	Discharged Charged	Measure the stem or between spring block and nut
Contact Gap	Open Closed	Charged Charged	Discharged Charged	Measure the travel of the operating rod insulator
Contact Erosion				Measure distance from bottom of insulated operating rod to bottom of stainless steel interrupter support
Trip Coil	Closed	Discharged	Charged	Measure between plunger button and coil housing
Close Coil	Open	Charged	Discharged	Measure under the collar to the end of plunger
Control Switches	Open	Discharged	Discharged	Depends on switch type See Chapter 8
Timing				See Chapter 10-10
Contact Speeds				See Figure 26
Motor Cutoff Switch				See Figure 47

TABLE #2 ADJUSTMENTS

ITEM	BREAKER	CLOSING SPRING	OPENING SPRING	MEASUREMENT
Contact Wipe	Closed	Charged	Charged	Adjust operating rod to obtain required dimensions
Contact Gap	Open	Charged	Discharged	Use buffer shims to advance or retard gap adjustment
Contact Erosion				Replace interrupter when wear exceeds 0.125"
Trip Coil	Closed	Discharged	Charged	Turn adjusting nut to obtain required dimension
Close Coil	Open	Charged	Discharged	Loosen set screw and move collar up or down
Control Switches	Open	Discharged	Discharged	Adjust link
Motor Cutoff Switch				See Figure 47

12-1 General

The following information covers in detail the proper method of removing various parts of the breaker in order to make any necessary repairs. This section includes only those repairs that can be made at the installation site, or parts of the breaker that are most subject to damage.

Important: Upon completion of any kind of repair work, all interrupter and mechanism adjustments must be checked.

Refer as needed to sections on mechanical and electrical adjustments.

12-2 Replacement of Interrupter (Assemblies)

Interrupters are supplied in complete interrupter assemblies which include the vacuum interrupter mounted in the interrupter support, and primary studs. It is recommended that the interrupter NOT be removed from the assembly in the field.

CAUTION: DO NOT ATTEMPT TO REMOVE OR REINSERT THE VACUUM INTERRUPTER IN THE INTERRUPTER SUPPORT ASSEMBLY. SPECIAL TOOLS AVAILABLE ONLY AT THE FACTORY ARE REQUIRED TO PREVENT DAMAGING THE VACUUM INTERRUPTER BELLOWS.

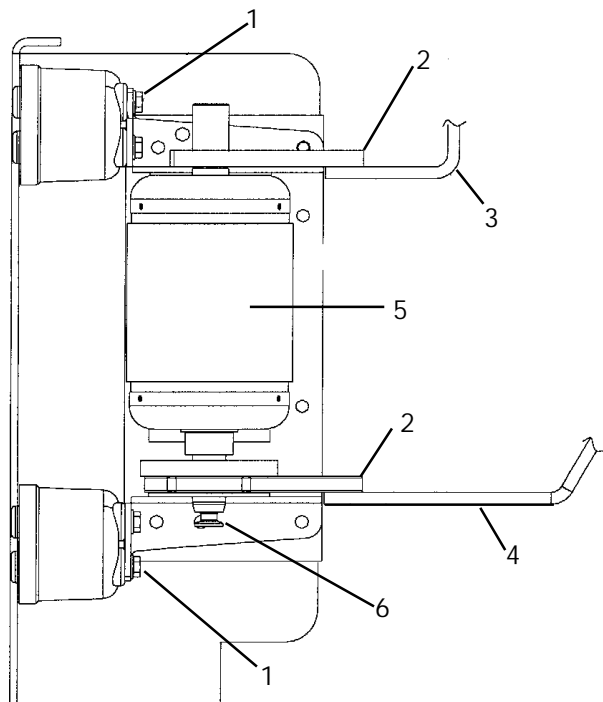

- 1. Mounting Bolts
- 2. Bus Runbacks
- 3. Primary Bus
- 4. Secondary Bus
- 5. Vacuum Interrupter
- 6. Movable Stem (clamp)

Figure 43. Pole Assembly

1. To remove the ML-19 element from the main truck or frame.
 - a. Remove rear cover; disconnect surge suppressors; remove rear interphase barrier support and interphase.
 - b. Disconnect element-to-primary bus at the element end.
 - c. Detach the Secondary Connector Bracket. Be sure to mark its location and retain the shims for re-installation. Detach the MOC Driver from the Frame.
 - d. Properly support the ML-19 element
Remove (4) bolts at top of frame
(2) bolts at sides
 - e. Lift element clear of frame.
2. Close the breaker element and remove the coupling clamp (Figure 23, Item 6). Hold the hex projection (Figure 23, Item 7) at the bottom of the operating rod insulator with a 1 inch wrench and loosen the adjacent lock nut with a 3/4 inch wrench. Screw down the lock nut and the operating rod insulator until clear of interrupter rod.

3. Remove interrupter assembly fasteners (8); four on the upper standoff and four on the lower. Remove the old assembly and install the new assembly.
4. Install the new assembly. Screw the operating rod insulator up to mate with the base of the interrupter rod. Install coupling clamp. Tighten coupling clamp cap screws, then loosen them 1-2 turns.
 - a. With continuity indicator across the contacts, back off the operating rod until the contacts separate, (continuity indicator off).
 - b. Advance operating rod until contacts touch, (continuity indicator on).
 - c. Advance operating rod two and one-half (2-1/2) additional turns.
 - d. Tighten lock nut to 40-50 foot pounds and the coupling clamp cap screws to 8-10 foot pounds.
 - e. Check wipe - must be 0.12 - 0.18 inch (set all three phases before measuring). It is not necessary that all three poles have the same wipe measurement as long as all three poles fall within the specified limits.
 - f. Check gap - must be 0.48 - 0.60 inch. Adjust if needed per CONTACT GAP ADJUSTMENT in MECHANICAL ADJUSTMENT (Chapter 11-3).
5. After the interrupter assembly is installed, check the erosion indicator. If the erosion indicator does not line up to the mark, adjust indicator (Figure 23).
6. Perform the VACUUM INTERRUPTER INTEGRITY TEST as described in ELECTRICAL CHECKS (Chapter 9-4).

CAUTION: PRIMARY DISCONNECT WIPE CAN ONLY BE CHECKED WHEN THE SWITCHEAR IS DE-ENERGIZED.

12-3 Primary Disconnect Bushings

The primary disconnect bushing assemblies should not be removed. Alignment of these items is critical to the function of the vertical lift equipment. If removal of these bushings is required, contact your local GE office for the location of a GE Authorized Service Center that can replace them.

12-4 Mechanism

Pin Retaining Rings - These rings are widely used in the ML-19 mechanism to retain pins. They can be installed and removed with a pair of standard pliers. Reuse is not recommended. To remove, slowly squeeze the removal ears to open the ring. To install, position ring in the pin groove and squeeze the installation ears closed, leaving no more than 1/16 inch gap between the ears. Retaining rings can be obtained from your local GE Sales office by ordering part number 0282A2015G001.

12-5 Control Switches

Control switches may be removed from their mounting brackets by disconnecting the wires and removing the mounting hardware. When replacing the switches, check that the correct type, normally open or normally closed, is used. Reinstall, wire, and adjust per DIMENSIONAL CHECKS - CONTROL SWITCH ADJUSTMENT.

12-6 Trip Coil Replacement

TOOLS REQUIRED

- 1/8" Allen wrench
- Needle nose pliers
- 7/16" Socket wrench
- 7/16" Box/combo wrench
- 1/4" Square drive ratchet
- 1/4" Square 3" extension
- Loctite #271 or equivalent

Perform the operation in the following sequence: Reference Figure 44

1. Charge closing spring and install gag tool.
2. Depress the close and then the trip buttons.
3. Pump the manual close handle 3 - 4 times.
4. With the 5/16" Allen wrench, remove the pivot bolt (Figure 49) on the closing spring (Figure 49, Item 3).
5. Remove the closing spring.
6. Disconnect the trip linkage tension spring (Figure 44, Item 4).

7. Remove the four bolts (item 6) securing the trip coil brackets to the mechanism side plate. See Figure 44. Slide the coil assembly toward the front of the mechanism, freeing the plunger from the slotted positive interlock arm.
8. Cut the coil wires and remove the coil and plunger.
9. To install and secure the new trip coil to the mechanism side plate, reverse the above procedures and connect the leads with insulated butt connectors (Figure 44).
10. Install the interlock bracket and tension spring.
11. The collar and washer (Figure 44, item 3 and 7) must be positioned below the positive interlock cam, Figure 44 item 9, slightly touching.

12. The set screw in the collar (Figure 44, item 3) should then be tightened to the plunger extension. The adjustment screw (Figure 44, item 8) must not be readjusted.

Apply locite to the threads on the pivot bolt. Charge the breaker and electrically close and trip the breaker to make certain the reassembly of the mechanism is correct.

NOTE: THE POSITIVE INTERLOCK MUST BE CHECKED AFTER REPLACING A TRIP COIL ON A BREAKER. SEE CHAPTER 11 FOR ADJUSTMENTS.

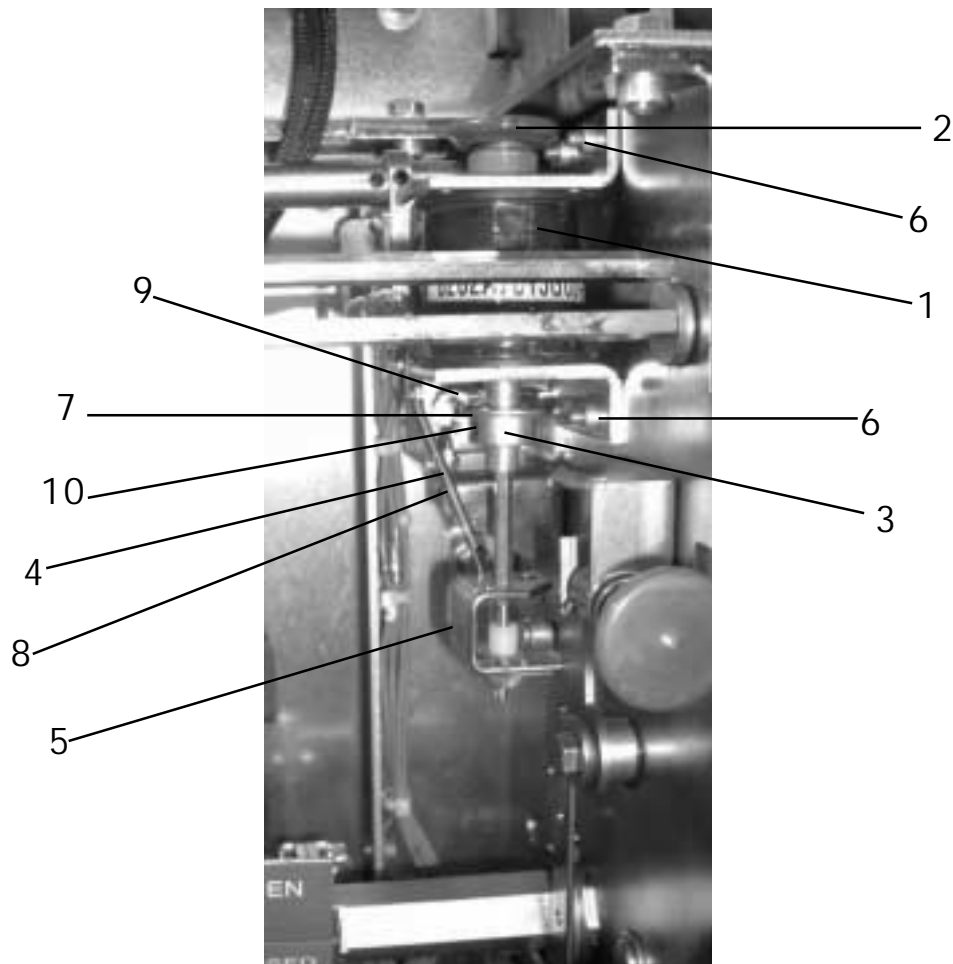

- | | |
|---------------------|----------------------------|
| 1 Trip Coil | 6 Trip Coil Mounting Bolts |
| 2 Plunger Button | 7 Washer |
| 3 Collar | 8 Adjusting Screw |
| 4 Tension Spring | 9 Positive Interlock Cam |
| 5 Interlock Bracket | 10 Set Screw |

Figure 44. Trip Coil and Linkage (Closing Spring Removed)

12-7 Closing Coil Replacement

Reference Figure 35 and 36. Disconnect the closing latch actuator tension spring (item 2). Remove the "X" washer from the rear of the plunger pin (item 3). Slide the pin forward, freeing the close coil for the actuator.

Remove the four bolts securing the close coil (item 5) to the side plate. Cut the leads to the close coil (item 5) and remove it. Reassemble the coil and housing with plunger. Use the four bolts over and, connect the leads with insulated butt connectors. Assemble the plunger pin and install a new "X" washer. Attach the tension spring, the collar (item 8) and washer, must be under the actuator arm and must be on top of item 4. Tighten to the dimensions shown.

NOTE: THE POSITIVE INTERLOCK MUST BE CHECKED AFTER REPLACING A TRIP COIL OR CLOSE COIL. SEE CHAPTER 11 FOR DETAILS ON CHANGING THE COILS OUT.

The Final Adjustment

To adjust the closing coil linkage with the positive interlock roller (Figure 1, Item 11), the breaker must be closed and charged. Rotate the positive interlock roller and before reaching the dimension shown (1.195). The positive interlock arm (Figure 36) moves the close plunger downward, discharging the breaker. The collar may be moved up or down to discharge the breaker. After adjustment, tighten both screws. See MECHANICAL ADJUSTMENTS section under CLOSE COIL PLUNGER.

12-8 Auxiliary Switch Replacement

With the breaker open and the closing spring discharged, remove outer "X" washer from auxiliary switch pin on the main drive shaft. Remove mounting hardware securing the auxiliary switch to the side sheet, slide switch and bracket from breaker. Observe and make note of the direction of the index mark on the end of the shaft and the position of the operating link in relation to the main drive shaft. Loosen set screw and remove crank. Reference Figure 46.

Remove mounting hardware securing auxiliary switch to the mounting bracket. Before removing any wires from switch terminals, make sure they are properly tagged with switch terminal numbers to assure proper placement on new switch. Remove wires.

To install new switch, attach leads then install switch, or install switch then attach leads depending upon the type of switch and its terminal accessibility. Install switch shaft in operating link with index mark aligned as noted above. Reverse above procedure to complete installation.

Table 3. ML-19 Control Devices and Voltages

Nominal	Charge Motor Pt#0177C5050Gxxx		Close Coil Pt#0209B7340gxxx		Trip Coil - 5 Cycle Pt#0209B7015Gxxx	
	Current Amps	Windup Amps	Current Amps	Range Volts	Current Amps	Range Volts
48VDC	34	9.3	9.6	38-56	22.8	28-56
125VDC	23	4.9	5.4	100-140	6.2	70-140
250VDC	18	2.4	2.5	200-280	5.5	140-280
340VDC*	N/A	N/A	N/A	N/A	4.3	280-380
120VAC	35	4.9	5.2	104-127	cap trip*	N/A
240VAC	20	2.5	2.5	208-254	cap trip*	N/A

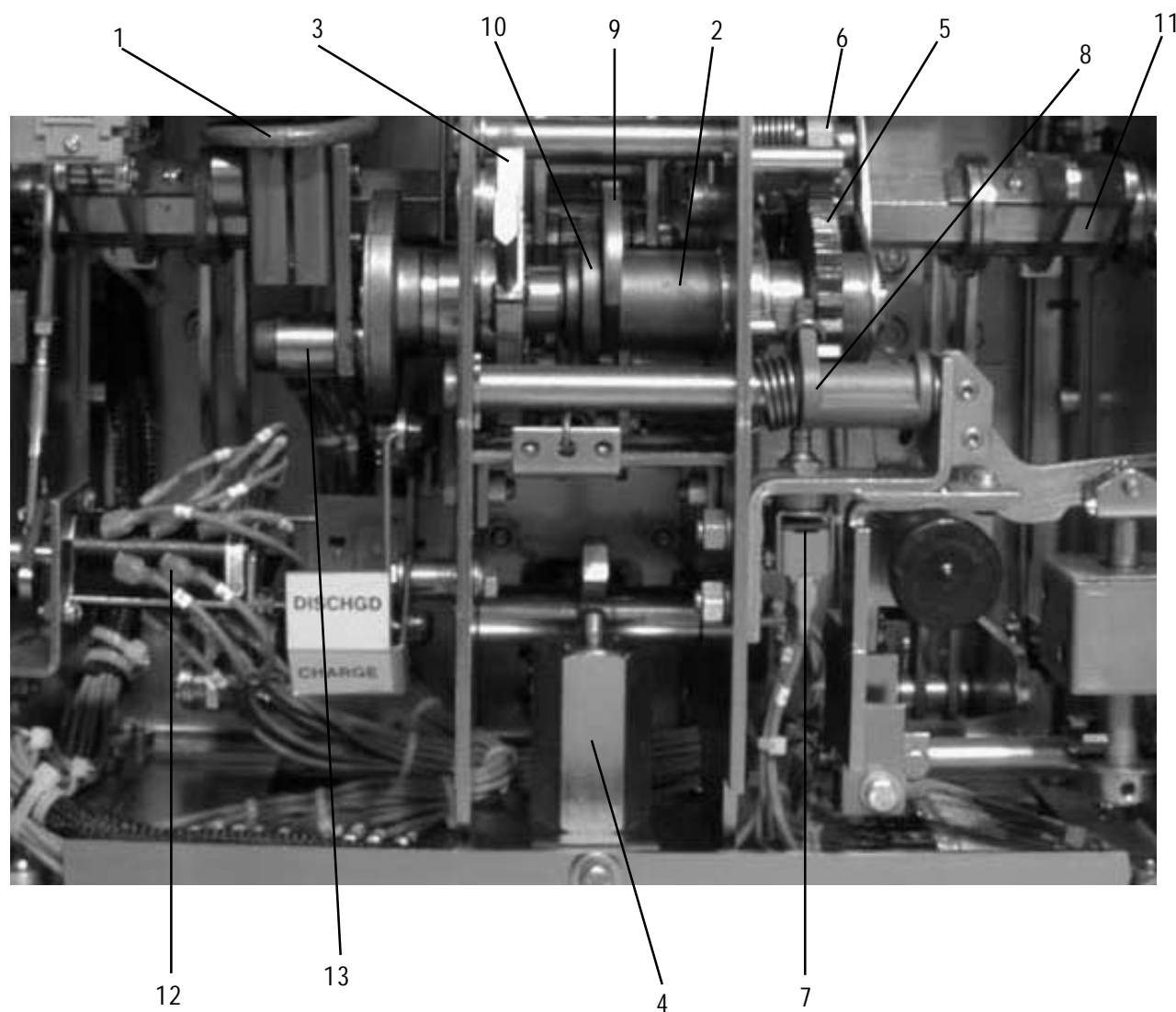

- | | |
|------------------------------------|----------------------------|
| 1 Close Spring | 7 Close Latch Check Switch |
| 2 Cam Shaft | 8 Close Latch |
| 3 Manual Charge and One-way Clutch | 9 Close Cam |
| 4 Buffer / Overtravel Stop | 10 Prop |
| 5 Ratchet Wheel | 11 Main Shaft |
| 6 Driving Pawl | 12 Auxiliary Switch |
| | 13 Pivot Bolt |

Figure 45. Front View of ML-19 Breaker Mechanism (Lower)

12-9 Motor Replacement

With the breaker open and the closing spring discharged, disconnect motor leads. Remove three (3) 3/8-16 hex capscrews securing the motor to the mechanism plates. Disengage the motor output shaft from the charge linkage arms and withdraw motor.

To install the new motor, reverse the above procedure.

12-10 "Y" Relay Replacement

Before removing the "Y" relay, make sure all leads are marked with terminal locations (figure 41). Next, disconnect all leads and remove the two fasteners securing the "Y" relay's shock absorbing mounting bracket to the mechanism rear plate. Withdraw relay and bracket. Remove fasteners securing relay to mounting bracket.

Reverse above procedure to install new anti pump relay.

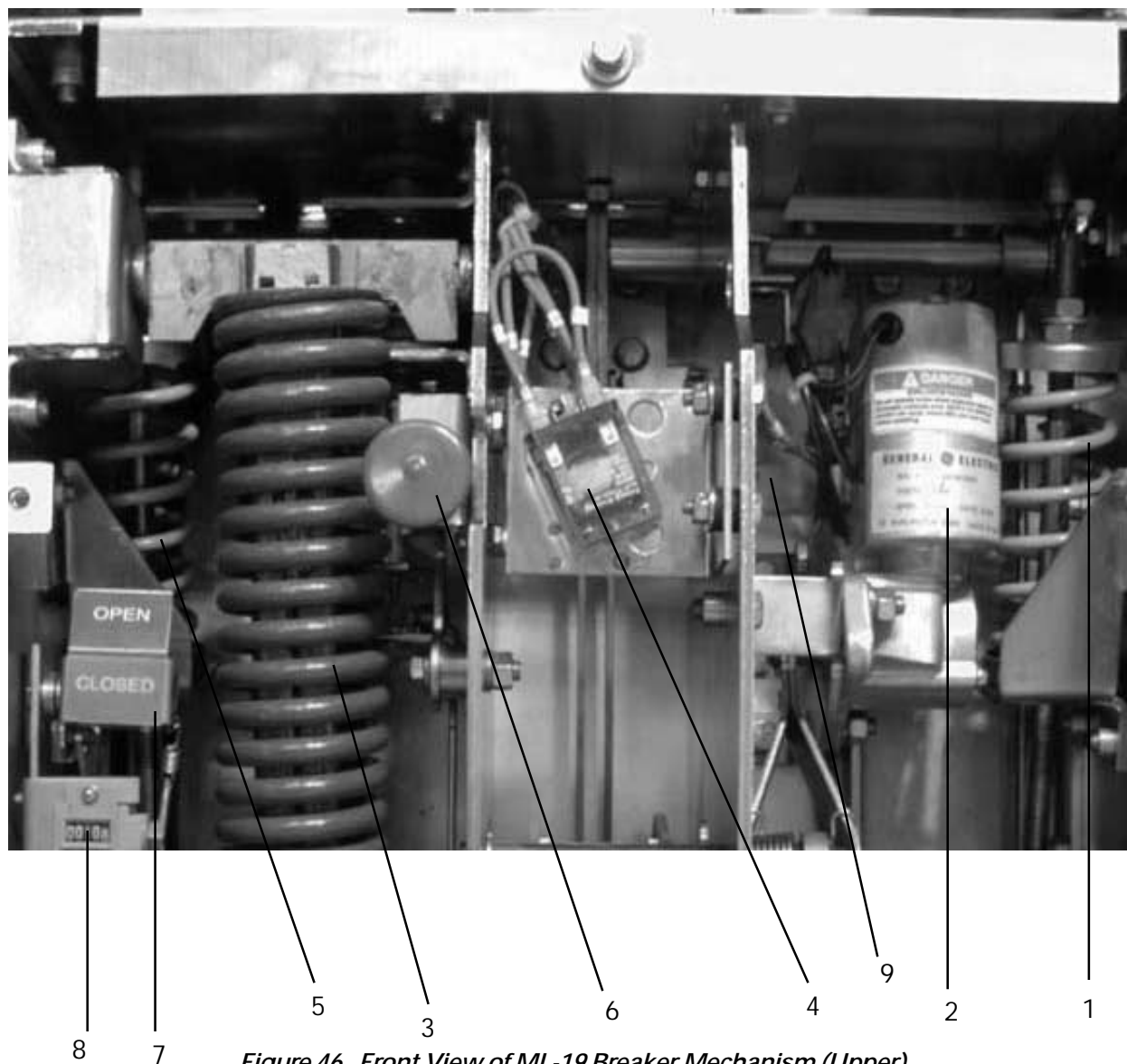

Figure 46. Front View of ML-19 Breaker Mechanism (Upper)

- | | | | |
|---|-----------------|---|----------------------|
| 1 | Opening Spring | 5 | Opening Spring |
| 2 | Charging Motor | 6 | Manual Trip Button |
| 3 | Close Spring | 7 | Open/Close Indicator |
| 4 | Anti-pump Relay | 8 | Counter |
| | | 9 | Motor Cutoff Switch |

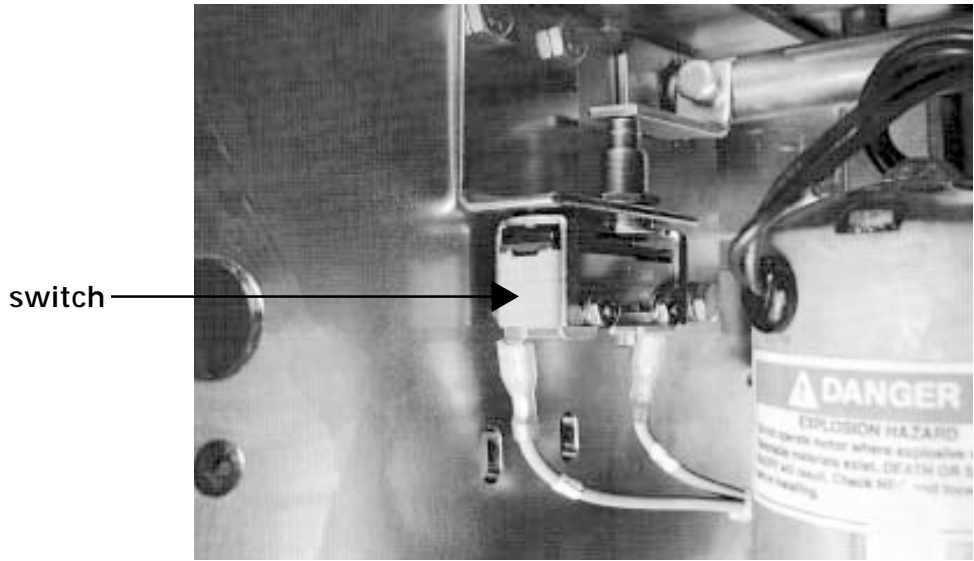
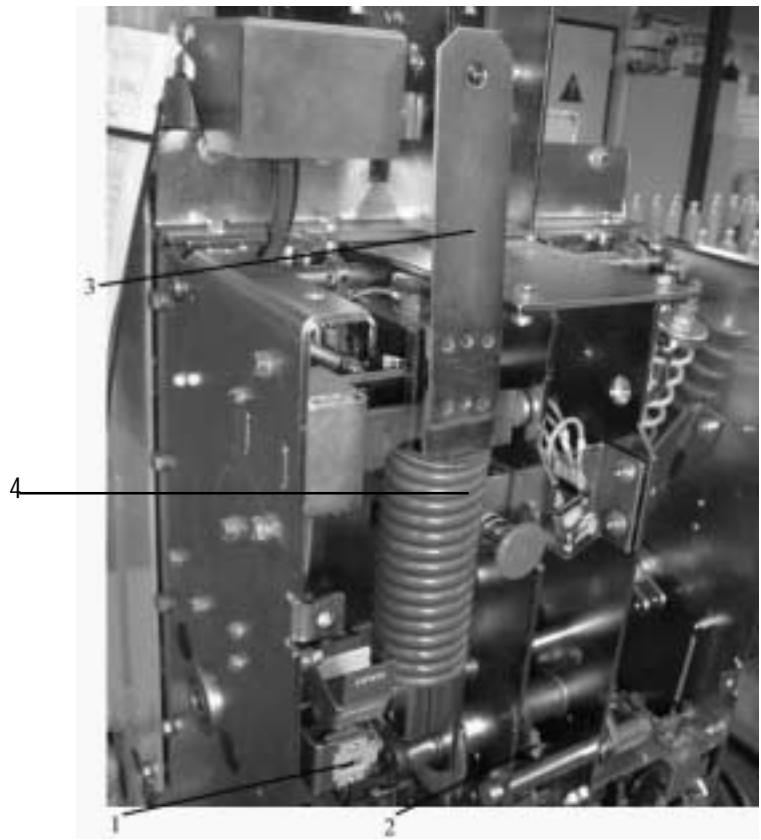

Figure 48. Motor Cutoff Switch



- 1 Counter
- 2 Manual Charge Mechanism
- 3 Gag Tool
- 4 Closing Spring

Figure 49. Closing Spring Gag

It is recommended that sufficient renewal parts be carried in stock to enable the prompt replacement of any worn, broken or damaged parts. A stock of such parts minimizes service interruptions caused by breakdowns, and saves time and expense. When continuous operation is a primary consideration, more renewal parts should be carried, the amount depending upon the severity of the service and the time required to secure replacements.

Renewal parts which are GE furnished may not be identical to the original parts, but they will be interchangeable. Verify that the parts are original GE parts of operational problems may occur.

A separate Renewal Parts Bulletin DEF-008 may be available from your local GE Sales office.

13-1 Ordering Instructions

1. Always specify the complete nameplate information. Include the manufacturing date of both the breaker and the mechanism. See Figure 50.
2. Specify the quantity, catalog number (if listed), reference number (if listed), and description of each part ordered, and the parts bulletin number.
3. Standard hardware, such as screws, bolts, nuts, washers, etc. are not listed in this bulletin. Such items should be purchased locally.
4. For prices or information on parts not listed in the Renewal Parts Bulletin DEF-008, refer to the nearest GE office.

Figure 49. Front View of ML-19 Mechanism with Front Cover Removed

1	Opening Spring	8	Counter	14	Close coil adjustment collar
2	Charging Motor	9	Manual Charge Lever	15	Close latch check switch
3	Close Spring	10	Positive Interlock Switch	16	Opening dashpot
4	Manual Close Button	11	Close Relay	17	Auziliary switch
5	Charge/Discharge Indicator	12	Cam shaft	18	MOC Plunger linkage
6	Manual Trip Button	13	Close coil	19	Positive interlock bar
7	Open/Close Indicator				

Location of nameplates in Type AM Magne-blast Vertical Lift Lineup

Shown below is a typical switchgear lineup.....

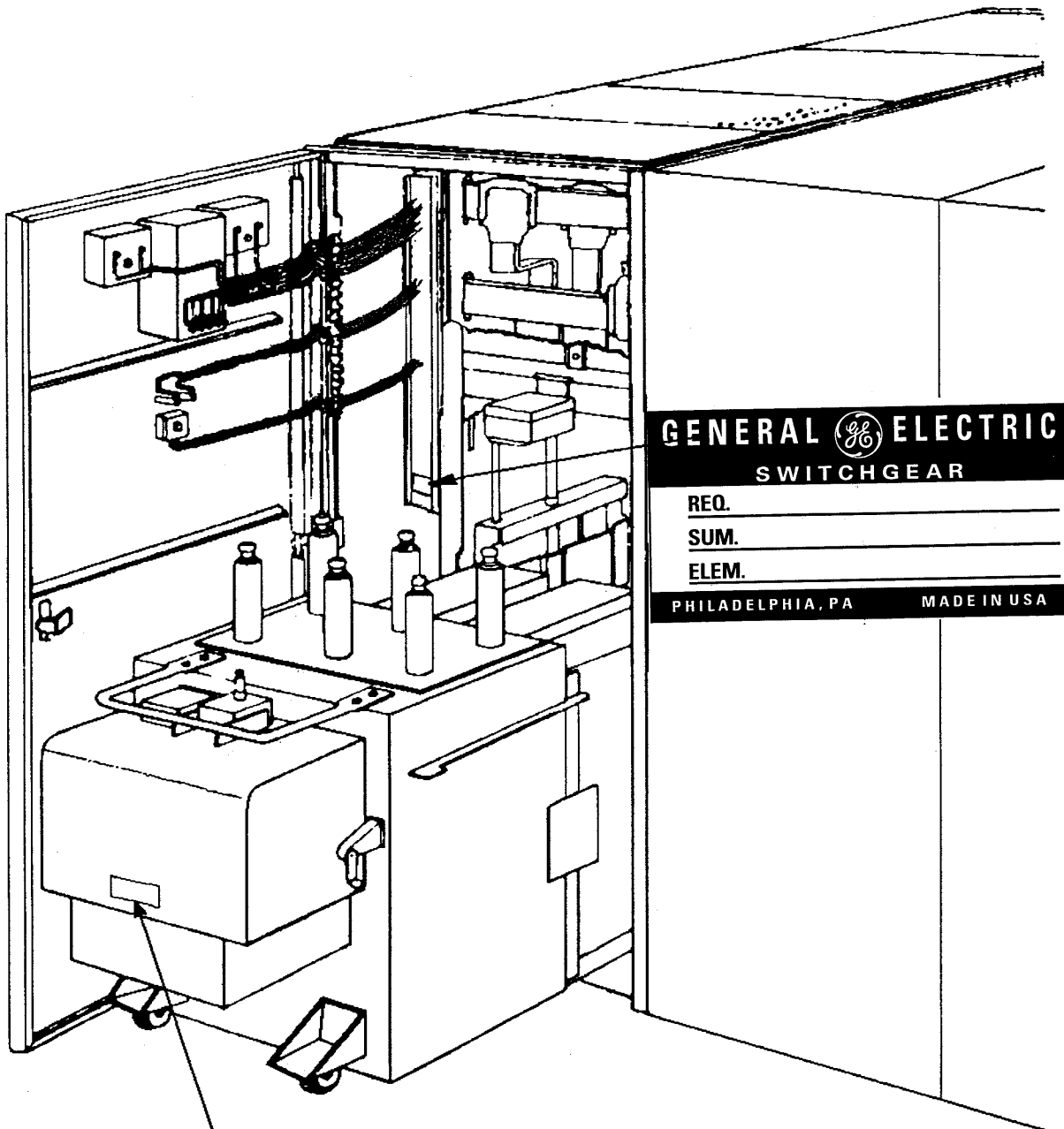

GE PowerVac Breaker		Type VBI 4.16 - 250	
		Ser. No. 0357A4157-001-03	
Rated Max		Impulse	
Voltage	5 KV	Rated Amp.	1200 HZ 60
		Withstand	60 KV 5 CYC
Rated Short		Rated Voltage	
Circuit Amps	29 KA	Range Factor	1.24
		Close & Latch	Capability Amp 60 KA
Close		Closing	Volt
Coil	0282A73406002	Volts	125 DC
		Amps	6.0
		Range	100-140
Trip Coil -1	0282A70156006	Volts	125 DC
		Range	70-140
Trip Coil -2		Volts	
		Tripping Amps	Range
Charging Motor	0177C50506001	Volts	125VDC
			HZ
Connector Diagram	020988250P002	Wt.	470 LBS.
		Mech.Type	ML-18
		Date Mfg.	4/99
Vac. Inter. Type	50F	Req:	625-1222W
		SO:	977673
Caution	Before Installing Or	GE Industrial Systems W. Burlington, IA 52655 USA	
	Operating Read Instr.		
	DEH 40012		

Figure 50. Schematic of ML-19 Mechanism

14-1 Introduction

The breaker cubicle sub-assembly is normally the existing Magne-blast stationary housing for the removable breaker unit. It contains the primary disconnects, elevating mechanism, buses, current transformers, and secondary control wiring.

14-2 Description of Major Components

1. Breaker Enclosure

The existing Magne-blast enclosure consists of a compartment with a hinged door or panel. Terminal blocks, fuse blocks, and some control devices are mounted inside the enclosure on the side sheets.

2. Breaker Elevating Mechanism

The elevating mechanism is designed to raise the breaker unit into the operating position and to lower the breaker to the disconnected position. It consists of a motor, heavy duty jack screws, jack nuts, and a carriage frame. Rails are built into the breaker frame to guide it into position. By means of interlocks, the breaker cannot be lowered or raised until it has been tripped. The breaker contacts can only be closed when the breaker is in the connected position. For more detail, refer to Chapter 4.

3. Primary Disconnects

The primary disconnect devices utilize silver to silver contacts to insure against reduction of current carrying capacity due to oxidation of the contact surfaces. These contacts are of the high pressure line contact tube and socket design, the tube being backed up by heavy garter springs to insure contact pressure.

4. Buses

The main buses are enclosed in a metal compartment with removable covers to provide accessibility. The buses are supported by flame retardant, track resistant, glass laminate insulating material and porcelain, which is practically impervious to moisture, and an excellent dielectric. No additional coating is necessary.

The bus insulation is an extruded thermoplastic insulation sleeve, suitable for 105 degree C operating temperatures. The bus bars are inserted into the sleeves leaving only the bolted joints exposed. The bus terminates before and after the breaker unit. Current transformers may be located along the bus, on either side of the breaker, for control applications.

5. Breaker Testing Provisions

Optional provisions for testing the breaker unit after removing it from the cubicle can be furnished. The test equipment can be located on a panel adjacent to the breaker compartment. It consists of a test coupler to provide control power to operate the breaker, and push buttons to trip and close the breaker electrically.

6. Connections

The main bus bars and other connection bars are made of copper, and the contact surfaces are silver plated. All field assembled joints in the primary conductors should be made as follows:

1. Wipe silver clean with a clean cloth and denatured alcohol. If badly tarnished, use a non-abrasive silver polish. Do not use steel wool, sandpaper, or any abrasive on the silvered surface. Avoid handling of cleaned surfaces as much as possible.
2. After cleaning, apply a light coating of grease, 0282A2048P009, to the silvered surfaces so that the contact area will be thoroughly sealed. Using a standard washer, lock washer, and nut, together, tighten joints to the torque values shown below.

BOLT CONNECTION TIGHTENING

Bolt Size	Torque
1/2 x 13	50 - 60 foot pounds
5/8 x 11	60 - 70 foot pounds

7. Ground Connection

A ground connection is made between the breaker ground shoe and the compartment ground bus.

8. Door Alignment

The existing Magne-blast compartment should have been properly adjusted and leveled during the original installation. Proper door alignment can be verified as follows.

The top of each door should be level with the adjacent doors; the sides of each door plumb; the surface of each door flush with the adjacent door; and, the space between adjacent doors equalized to permit their free swing and present a neat appearance. The door stops should be adjusted to permit a door swing of approximately 105 degrees.

If it is necessary to align the doors of the breaker compartment, the following procedure should be followed.

1. Doors may be raised or lowered vertically, or moved forward or backward horizontally, by loosening the hinge mounting nuts on the left side sheet and shifting the hinge and door assembly as allowed by the slotted holes in the hinge.
2. Doors may be shifted to the right or left by adding or removing washers or shims from between the hinge and side sheet.
3. Doors may be plumbed by slightly bending the appropriate hinges. To do this, open the door and insert a drift pin in either of the two holes in the hinge. Pulling forward on the drift pin will move the door to the right, and pushing back will move the door to the left. Adjust each hinge individually as required to plumb the door.

14-3 Testing and Inspection

1. General

Although the breaker has been completely tested at the factory, a final field inspection and test should be made to be sure that the equipment has been properly installed and that all connections are correct and have not become loose in transportation. Reference Chapter 4.

WARNING: THE PRIMARY EQUIPMENT SHOULD BE COMPLETELY DE-ENERGIZED WHILE THE TESTS ARE IN PROGRESS.

2. Breaker Testing

The operation of the breaker with its associated devices may be tested outside the unit by use of the test coupler. Reference Chapter 9.

3. Hi-potential Testing

Hi-potential tests to check the integrity of the switchgear insulation is not necessary, if the insulation has been previously checked during maintenance. Should the purchaser desire to make hi-potential tests, the test voltage should not exceed 14kV AC at 60 Hz. This voltage is 75% of factory test voltage and is in accordance with ANSI standards.

4. Breaker Positioning

Before proceeding to place the breaker in the operating position, the steps as outlined in Chapter 4 must be taken.

WARNING: DO NOT INSTALL OR REMOVE THE BREAKER OR MAKE ADJUSTMENTS UNLESS THE BREAKER IS OPEN.

- 4.1. Rub a small amount of 0282A2048P009 lubricant on the silvered portion of the breaker studs, ground shoe, and 16 secondary coupler pins, to form a thin coating for contact purposes.
- 4.2. Lower the elevating mechanism lifting brackets until the lifting brackets are in the fully lowered position. The breaker should then enter the housing freely. After first assuring that the breaker is in the open position, push the breaker into the unit until it rests against the rear of the front lifting saddle of the elevating mechanism.
- 4.3. The clearance between the interference block on the breaker and the interference block on the interlock mechanism should be from .063" to .125". Figure 6.

WARNING: AGAIN, BEFORE PROCEEDING WITH THIS CHECK, IT IS NECESSARY THAT THE PRIMARY CIRCUITS BE DE-ENERGIZED.

- 4.4. To elevate the breaker, place the elevating control selector switch on the elevating motor to "RAISE". A clutch handle under the elevating motor is then pulled forward until a limit switch engages to raise the breaker into the unit. Carefully raise the breaker and while elevating, note that the shutter slides open and the breaker studs center with respect to the openings in the stationary disconnecting devices or damage to the contacts may result.
- 4.5. Hold the clutch handle in the forward position until a limit switch on the structure opens to stop the motor at the end of the upward travel of the breaker. The springs will charge when the clutch handle is released. Figure 53.

CAUTION: THE MOTOR RAISE/LOWER SELECTOR SWITCH MUST NOT BE USED TO ENERGIZE OR INTERRUPT MOTOR CIRCUIT AT ANY TIME.

- 4.6. When the breaker is fully elevated, the clearance between the breaker lifting rail and the upper stop bolts should not be more than .125" and not less than .094".

- 4.7. The positive interlock roller should be centered in the upper "VEE" and the interlock roller should have 1/16" clearance to the stationary plate directly under it. Figure 6 and 53.
- 4.8. To lower the breaker, proceed the same as for raising, except, place the selector switch to "LOWER".
- 4.9. To raise or lower the breaker, the clutch must be held in the engaged position, otherwise a spring will return it to its disengaged position and open the electrical circuit to the motor.
- 4.10. The breaker may be raised or lowered by an emergency hand crank which can be inserted after removing the motor. The motor is removed by unlatching the motor assembly from its support and disconnecting the motor lead plug.

After removing the motor, insert the manual crank and pull the clutch forward. Rotate the crank until the coupling engages the clutch. The clutch handle will be held in the down position by a latch on the crank assembly. The breaker must be open before the crank can be inserted and held in the clutch coupling.

- 4.11. After the breaker is lowered and withdrawn from the unit, inspect the contact surfaces of both the breaker studs and the stationary disconnecting devices.
- Each segment of the stationary disconnecting device should make a heavy impression in the contact lubricant on the breaker studs. Contact wipe should start not less than .125" from the top of the contact ball, although each contact need not start at the same location. Figure 9.
 - The penetration of the breaker stud inside the stationary disconnecting device, as indicated by the contact lubricant, should be .75" to .875". This indicates that the breaker studs contacted at the full pressure center of the silver band on the stationary disconnecting device. Figure 9.
 - Should the inspection of the contacts show that the breaker is not being raised

to the proper position, readjust the upper stop bolts and limit switches to raise or lower the breaker to the proper location. Lock the stop bolts in the new position. Figure 6.

- If proper contacting cannot be attained by the above methods, additional adjustments may be necessary.

CAUTION: DO NOT MAKE THESE ADJUSTMENTS. CONTACT YOUR LOCAL GE REPRESENTATIVE FOR ADDITIONAL INFORMATION.

5. Positive Interlock

The cell-side positive interlock cam causes a **closed** and charged breaker to open and all springs to discharge. While engaged the positive interlock cam prevents closing the primary contacts when the breaker is being raised or lowered by holding the breaker mechanism in a trip condition. The breaker mechanism holds the positive interlock switch open during racking and prevents the charging motor from operating. Figure 6 and 53.

- Lower the elevating mechanism lifting brackets until the lifting brackets are in the fully lowered position. The breaker should then enter the housing freely. After first assuring that the breaker is in the **open position**, insert the breaker into the unit until it rests against the rear of the front lifting saddle of the elevating mechanism. Reference Figure 6 and 53.
- When inserting a breaker into a unit for elevating, engaging the elevator clutch will trip a closed breaker and discharge the opening and closing springs if they are energized.

WARNING: AGAIN, IT IS EMPHASIZED THAT BEFORE PROCEEDING WITH THIS CHECK, IT IS NECESSARY THAT THE PRIMARY CIRCUITS BE DE-ENERGIZED.

- Open the breaker.** Elevate the breaker to the raised position. The positive interlock roller should engage into the upper Vee. Breaker can be electrically closed.
- Snap the selector switch to the "LOWER" position. Pull the clutch handle forward. The breaker should be open and the closing spring will discharge, when engaging the clutch and lowering the breaker.

WARNING: IF THE BREAKER IS IN THE CLOSED POSITION WHILE ATTEMPTING TO LOWER THE BREAKER, ENGAGING THE CLUTCH HANDLE WILL CAUSE THE BREAKER TO OPEN AND THE CLOSING SPRING TO DISCHARGE.

REMOVABLE ELEVATING MOTOR ASSEMBLY

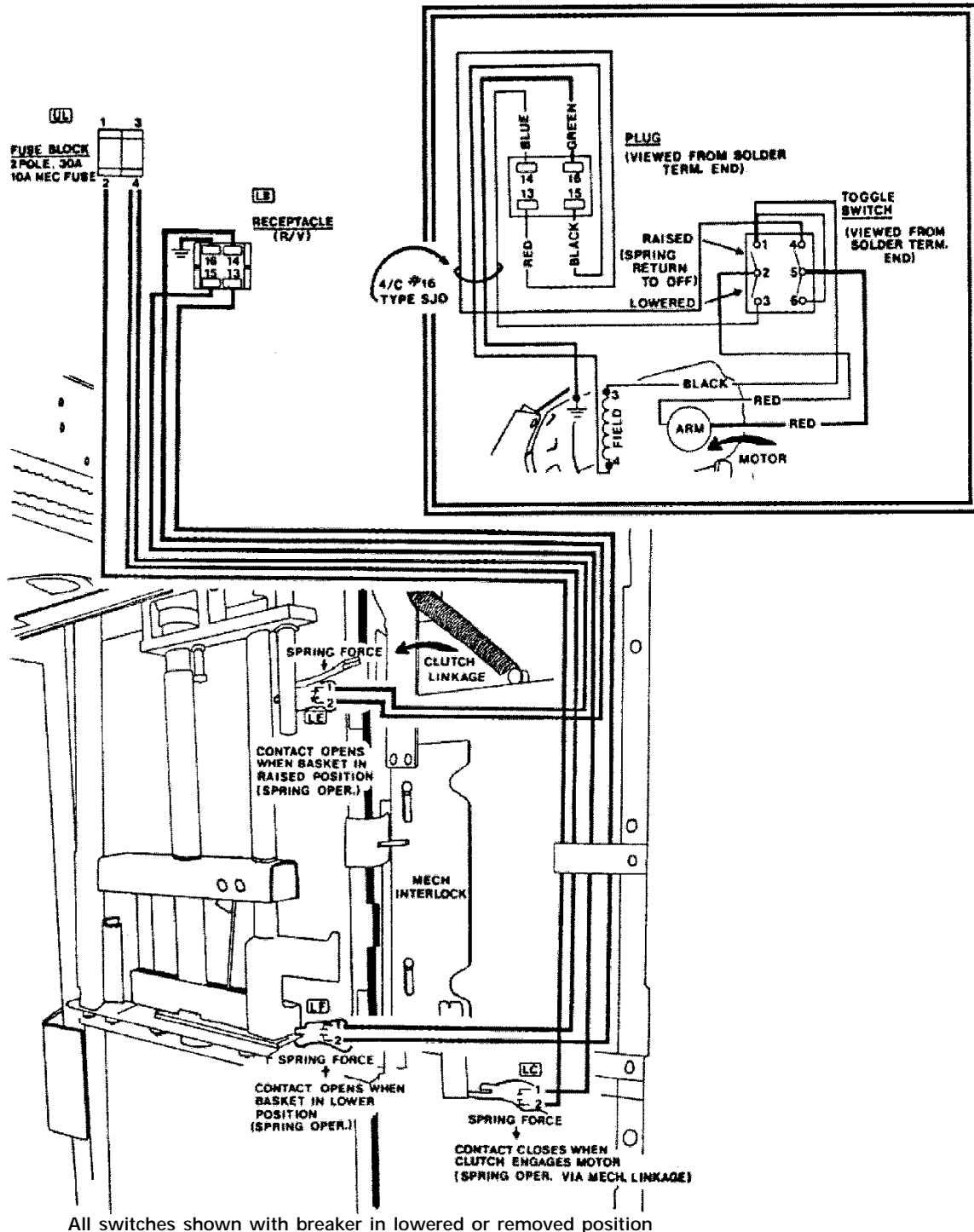

All switches shown with breaker in lowered or removed position

Figure 51. Typical stationary structure wiring

Table 4. Elevating Motor Troubleshooting

CORRECTIONS

IF ELEVATING MOTOR DOES NOT OPERATE:

1. Check Power Supply
2. Check fuses UL
3. Check and adjust mechanical clutch linkage to clutch switch LC
4. Check LC for proper performance
5. Check motor switch
6. Check motor
7. Adjust upper LE and lower LF limit switches for proper breaker position
8. Check and adjust leaf springs to provide proper tilt to operate limit switches
9. Check plug and receptacle for proper connections
10. Check clutch and mechanism

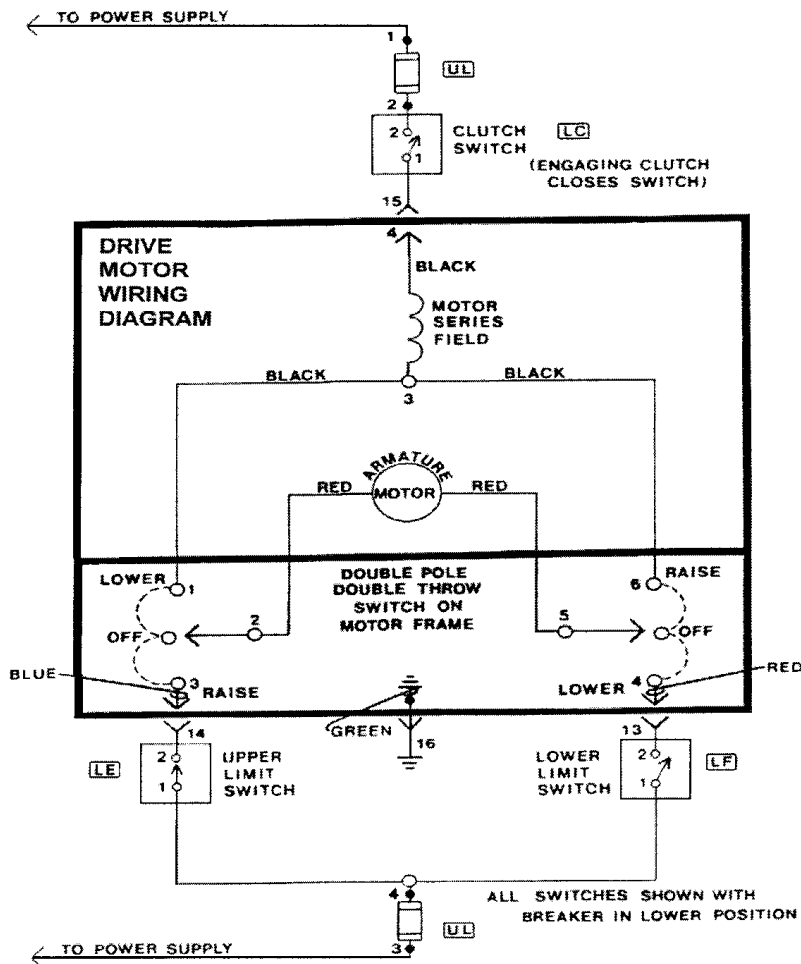

DO NOT USE RAISE/LOWER SWITCH TO STOP & START MOTOR.

Figure 52. Electrical schematic diagram for typical vertical lift elevating mechanism

6. Stationary Auxiliary Switch (MOC)

On units equipped with stationary auxiliary switches, the clearance between the end of the switch mechanism operating rod and the operating plunger on the circuit breaker should be 0 to 0.062" with the circuit breaker in the raised and open position. Figures 10 and 40.

Any adjustment in this dimension must be made on the auxiliary switch setting. Care should be taken to prevent destroying interchangeability of the circuit breaker by excessive adjustment. Consult GE nearest sales office.

7. Spring Discharge

When elevating or lowering the breaker, the positive interlock lever roller on the breaker interacts with the positive interlock cam in the cell. Subsequently...The closing spring is discharged and the breaker is trip-free. Figures 6 and 53.

CAUTION: IF THE INTERLOCK DOES NOT FUNCTION AS INDICATED ABOVE, DO NOT MAKE ADJUSTMENTS. CONTACT YOUR LOCAL GE REPRESENTATIVE FOR ADDITIONAL INFORMATION.

8. Space Heaters

Space heaters are provided in all equipment in order to keep the inside temperature several degrees higher than that outside. By maintaining a slight temperature differential, the heaters help facilitate drying and prevent condensation and the resulting corrosion and insulation deterioration which might occur.

Before energizing the heaters, be sure the power source is of the proper voltage, frequency, and phase arrangement, and is connected in accordance with the wiring diagrams furnished with the equipment.

Heaters should be visually inspected several times a year to assure they are operating properly. It is also recommended that the heaters be energized at all times and that thermostatic control NOT be used.

14-4 Breaker Compartment Maintenance

General

A regular maintenance schedule should be established to obtain the best service and reliability from the breaker compartment. Plant operating and local conditions will dictate the frequency of inspection required. For specific information regarding the maintenance of devices, relays, meters, etc., refer to the separate instruction book furnished for each device. The breaker testing device, which may be furnished as an option, provides a convenient means for maintaining the circuit breaker. Under normal operating conditions the protective relays do not operate, therefore, it is important to check the operation of these devices regularly.

A permanent record of all maintenance work should be kept, the degree of detail depending on the operating conditions. In any event, it will be a valuable reference for subsequent maintenance work and for station operation. It is recommended that the record include reports of tests made, the condition of equipment and repairs and adjustments that were made.

WARNING: BEFORE ANY COVERS ARE REMOVED OR AND DOORS ARE OPENED WHICH PERMIT ACCESS TO THE PRIMARY CIRCUITS, IT IS ESSENTIAL THAT THE CIRCUIT OR CIRCUITS BE DE-ENERGIZED AND BREAKERS BE WITHDRAWN TO A DISCONNECTED POSITION, AND TAGGED.

IF WORK IS TO BE DONE ON REMOTE EQUIPMENT CONNECTED TO A UNIT, THE BREAKER FOR THAT UNIT SHOULD BE PLACED IN THE DISCONNECTED POSITION AND TAGGED. ALSO, REMOTE EQUIPMENT SHOULD BE ISOLATED FROM ANY OTHER POWER SOURCES CONNECTED TO IT.

The primary circuits of the equipment are insulated in order to reduce the size of the equipment. However, this insulation, except in one of two instances, requires a certain amount of air gap between phases and to ground to complete the insulation integrity. Inserting any object in this air space, when equipment is energized, whether it be a tool or a part of the body, may under certain conditions, in effect, short circuit this gap and may cause a breakdown in the primary circuit to ground and cause serious damage or injury or both.

Care should be exercised in the maintenance and checking procedures that accidental tripping or operation of the protective devices is not initiated.

The equipment and connections should be given the following overall maintenance at least annually.

1. Thoroughly clean the equipment, removing all dust and other accumulations. Wipe clean the buses and supports with a clean cloth and denatured alcohol. Do not use solvents. Inspect the buses and connections carefully for evidence of overheating or weakening of the insulation.
2. Measure the resistance to ground and between phases of the insulation of buses and connections. Since definite limits cannot be given for satisfactory insulation resistance values, a record must be kept of the reading. Weakening of the insulation from one maintenance period to the next can be recognized from the comparison of the recorded readings. The readings should be taken under similar conditions each time, and the recordings should be adjusted to include the temperature and humidity.

Hi-potential tests are not required, but if it seems advisable, based on the insulation resistance tests or after repairs, the test voltage should not exceed 14kV AC, 60 Hz. These voltages are 75% of the factory test voltages and are in accordance with ANSI standards.

Potential transformers and control power transformers must be disconnected during high voltage testing.

3. Clean elevating mechanism and lubricate.
4. Check primary disconnecting device contacts for signs of abnormal wear or overheating. Clean contacts with de-natured alcohol.

Discoloration of the silvered surfaces is not ordinarily harmful unless atmospheric conditions cause deposits, such as sulfides, on the contacts. If necessary, the deposits can be removed with a good grade of silver polish.

Before inserting the breaker, apply a thin coat of 0282A2048P009 lubricant, to the breaker studs for lubrication.

5. Check tightness and continuity of all control connections and wiring.
6. If the equipment is equipped with heaters, check to see that all heaters are energized and operating.

POSITIVE INTERLOCK "OPTIONAL" PROCEDURES

The positive interlock system functions to prevent closing the breaker contacts when the breaker is being raised or lowered, and it prevents raising or lowering the breaker when the breaker contacts are closed. In most AM Breaker Metal-Clad Switchgear units, there is a breaker "Test Position" which allows you to functionally test the breaker without connecting to the bus. This position is usually about 5 inches from the breaker being fully lowered to the floor of the cubicle. When in the "Test Position", a secondary coupler cable must be used to connect the two secondary control circuits, since the breaker is in the partially lowered position.

The lower "Vee" notch in the position interlock cam plate, Figure 1A, allows closing and opening the breaker electrically.

NOTE: FOR IMPROVED SAFETY, IT IS RECOMMENDED THAT THE ABILITY TO FUNCTIONALLY OPERATE THE BREAKER IN THE "TEST" POSITION BE ELIMINATED AND THAT BREAKER FUNCTIONAL TESTING BE PERFORMED WITH THE BREAKER COMPLETELY REMOVED FROM THE CUBICLE.

A. By-Pass Installation.

The ability to electrically close and open the breaker in the "Test Position" is eliminated by covering the lower "Vee" notch in the positive interlock cam plate. Materials for accomplishing this modification are provided in Kit #xxxxxxxxxxxx, which can be furnished as an option, with the new vacuum breaker. This by-pass kit can be installed on existing GE M26 magne-blast breaker cubicles that have a lower interlock roller "Vee" notch on the positive interlock cam plate. In that case, the optional by-pass kit will be supplied. If additional by-pass kits are required for the remainder of the switchgear line-up cubicles, order the same kit number.

WARNING: FAILURE TO FOLLOW THE INSTRUCTIONS BELOW COULD CAUSE A CLOSED BREAKER TO BE RAISED TOWARDS THE CONNECTED POSITION, CAUSING INJURY OR DEATH TO THE OPERATOR AND EXTENSIVE EQUIPMENT DAMAGE.

To make the modification proceed as follows:

1. Remove and save the existing switch operator bracket.
2. Install the new switch operator bracket supplied with the kit, using the two existing 1/4 - 20 screws. Adjust the bracket in the exact same location as the removed bracket, in relation to the motor activation switch lever. Make sure that the lower "Vee" notch in the positive interlock cam plate is covered and that the edge is even with the front edge of the positive interlock cam plate. (Figure 2A and 3A).
3. Drill two 0.218 diameter holes in the positive interlock cam plate from locations in the new bracket supplied with the kit. See Figure 3A.
4. Install two 1/4 - 20x1/2 LG thread cutting screws (supplied with the kit).
5. Install #10-24 thread cutting screws (supplied with the kit).
6. Install existing switch operating bracket using 1/4x20x5/8 LG hex head capscrew with washers supplied with the kit.
7. All breaker cubicles that undergo this modification to the positive interlock cam plate must be checked according to the dimensions given in Figure 2A.
 - a. The 10-7/8" (-0" +1/16") dimension from the breaker to the front edge of the positive interlock cam plate must be verified and maintained prior to inserting a replacement VL vacuum breaker into the cubicle. See Figure 1A.
 - b. The 1/16" clearance between the stationary flag, just behind the upper "Vee" notch and the interlock roller must be maintained or reset, if required. The breaker should be in the fully raised position. See Figure 1A.

B. CHECKING FOR PROPER INTERLOCK AND TRIP-FREE FUNCTIONS BEFORE LOWERING THE BREAKER FROM THE ELEVATED POSITION.

1. STANDARD OPERATION: When the breaker is in the fully elevated and connected position, releasing the motor operating handle will return the positive interlock roller into the upper “Vee” notch in the interlock switches and energizing the circuit that will charge the springs. The breaker may now be closed.

In order to lower the breaker from the connected position, the breaker must be opened. If the breaker is not open, the operator can not, and should not be able to engage the clutch or activate the motor circuit. The positive interlock roller will remain locked and will not allow the interlock cam plate to move vertically far enough to activate the elevating motor.

2. MODIFICATION KIT CHECK: To test the function of the positive interlock system and trip-free function, the following checks should be made:

- a. With the breaker closed and in the elevated position, the positive interlock roller on the breaker must remain locked and not allow the motor handle to be moved far enough to engage the clutch and close the clutch switch contacts that energize the motor circuit. There should be 1/16” clearance between the clutch and motor coupler, when the motor handle is pulled forward.
- b. Disconnect the elevating motor plug from its socket.
- c. Trip the breaker to the open position.

- d. Using the manual charging, charge the closing springs in the breaker until the semaphore shows charged.
- e. Pull back the elevating handle on the motor so that the interlock roll is at the dimension shown in Figure 1A. Hold it in this position while pressing the manual close push button on the breaker. The main power springs must discharge and the breaker must remain open, as indicated by the semaphores on the front of the breaker. This indicates that the breaker contacts will not close during raising or lowering the breaker.

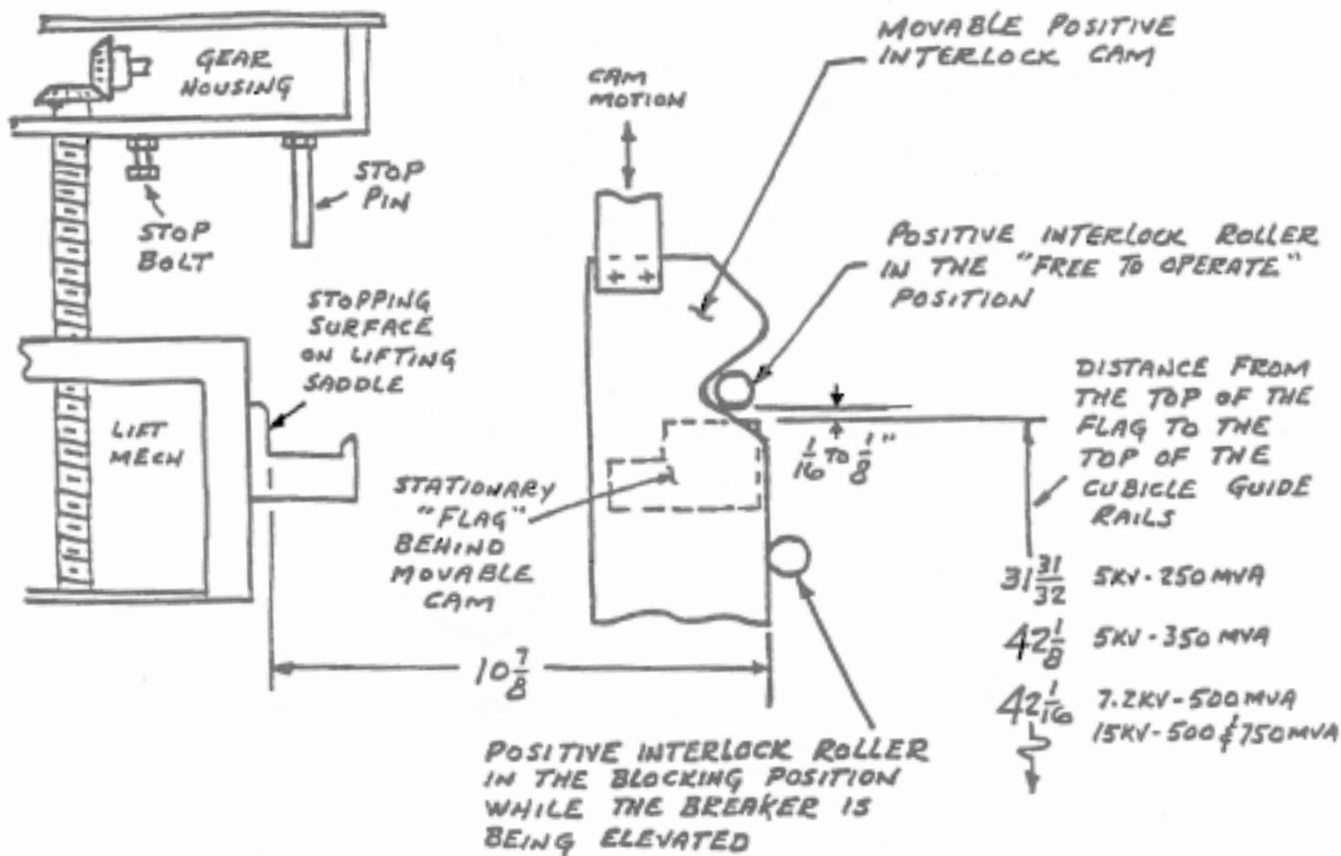

Appendix 1A. Positive Interlock system

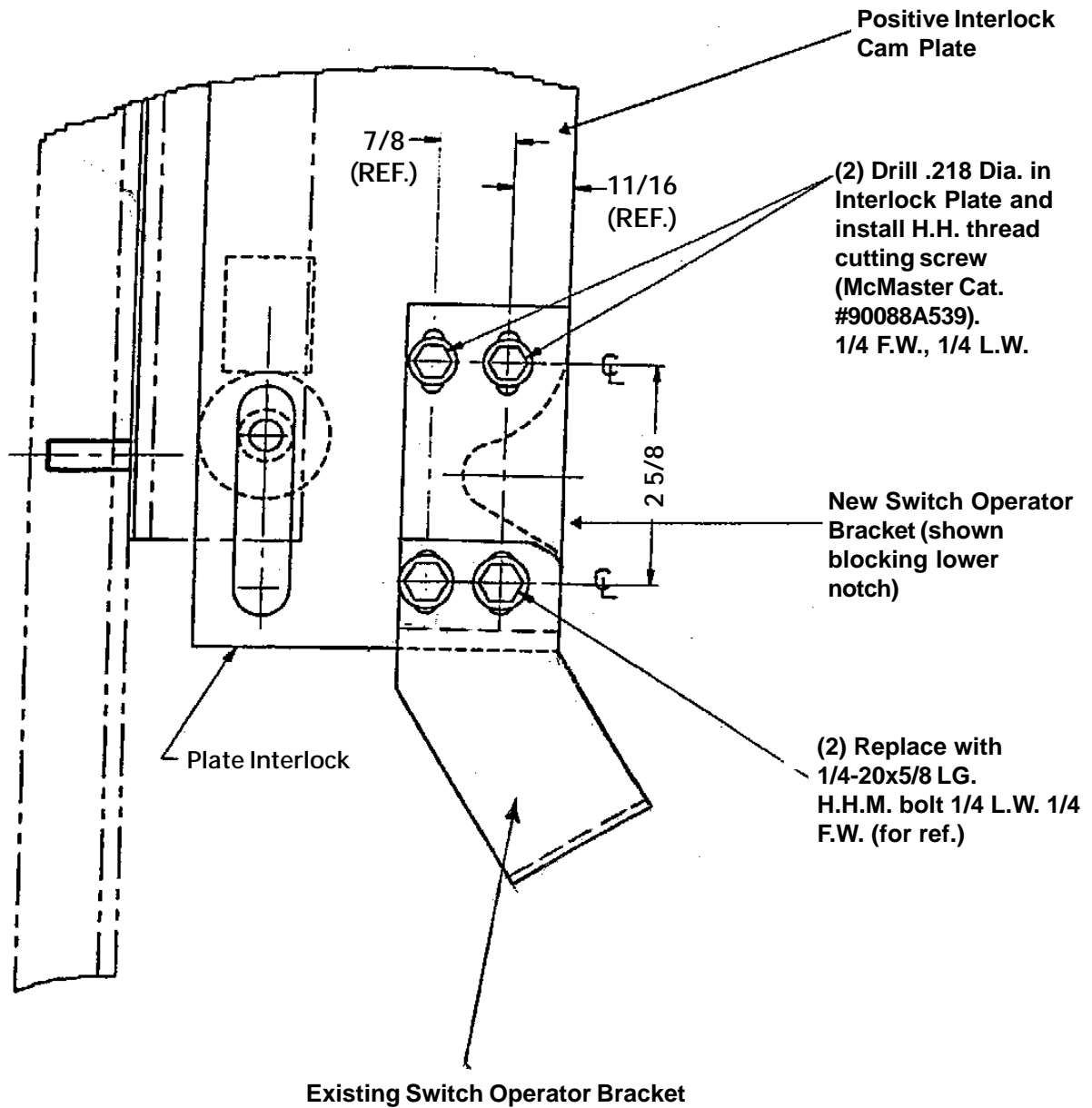

Right Inside View (Below Elevating Motor)

Appendix Figure 2A. Interlock Modification

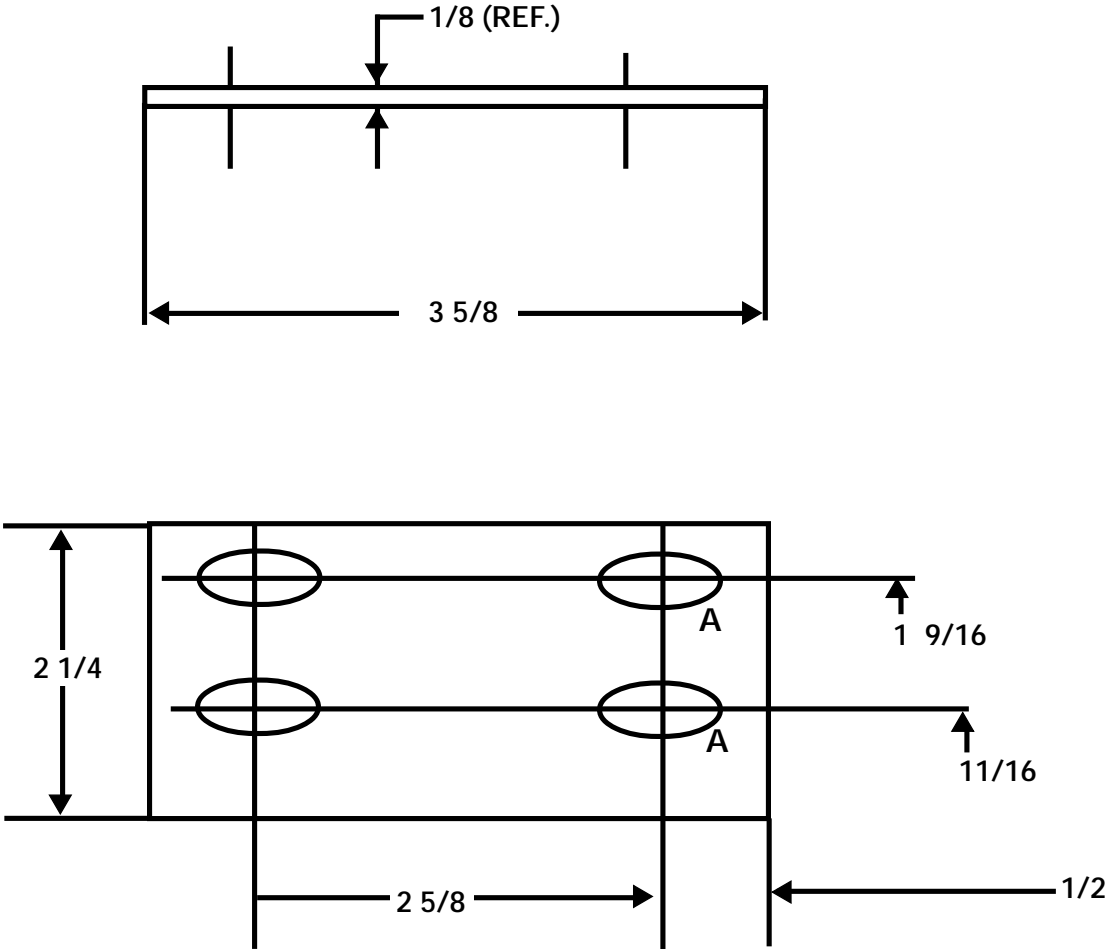

Appendix Figure 3A. Motor Operation Switch Actuator

REPORT NO.

FAILURE REPORTING FORM

Check **all appropriate blocks** and provide information indicated. For **major** trouble provide additional information requested on back of page supplemented with additional pages if necessary.

EQUIPMENT: Station _____ User Ident of Recloser _____

Equipment Nameplate # _____ Mfgr. _____ Type _____ Serial _____

Information KV _____ Inter Amps/MVA _____ Continuous _____

Amps _____ BIL _____

Recl Background: Shipped _____, Installed _____, Maintained _____, Modernized _____, Date _____

(Mo/Day/Yr) (Mo/Yr) (Mo/Yr) (Mo/Yr) (Mo/Yr)

Operational Counter Reading _____ Trouble _____

Location: Indoor Outdoor **Enclosure:** Non-metal Clad, Metalclad, GIS

Interrupter: Air Blast, Air Magnetic, Oil, SF₆, Vacuum, Other _____

ENVIRONMENT:

General: Industrial, Urban, Suburban, Rural, Sea Coast, Above 3300', High Contamination,

Other _____

Weather Conditions: Dry, Rain, Lightning in Area, Snow, Fog, Freezing Rain, Frost, Condensation,

Temp. Trend - Rising, Falling, Steady, Extreme Cold, Temperature _____ ° F,

Wind - Calm, Light, Strong-Steady, Strong-Gusty

External Mechanical Stresses Involved: Normal, Earthquake, Wind, Abnormal Terminal Loading, Other _____

Nominal System voltage _____

TROUBLE:

When Discovered: Installation, In Service, Maintenance, Test, Other _____

Recloser Mode at Time of Trouble: De-energized, Closed, Open, Tripping, Closing, Reclosing, Fault Interruption, Load Switching, Line Switching

Recloser Response at Time of Trouble: Not Called to Operate, Performed as Intended, Unsatisfactory Operation, Failed to Operate

Subsystem in Trouble: External Insulation to Gnd, Internal Insulation to Gnd, Insulating Medium, Isolating Contact, Bushing, Interrupter, Seals-Gaskets, Air System, SF₆ System, C.T., Resistor Sw or Aux. Int., Voltage Grading Dev, Line Terminals, Compressor, Heater, Electrical Controls, Wiring, Operating Mechanism, Mechanical Linkage, Other _____

State Specifically What Failed (With Instr. Book Ref.): _____

Has it occurred before on this type of recloser? No, Yes, How many times _____

State How Problem was Corrected: _____

POSSIBLE CAUSE: Design/Manufacture, Shipping, Storage, Installation, Instructions, Maintenance, Wear/Aging, Animal/Birds, Other, Not Obvious

Comments and Suggestions: _____

These instructions do not purport to cover all details or variations in equipment nor to provide for every possible contingency to be met in connection with installation, operation or maintenance. Should further information be desired or should particular problems arise which are not covered sufficiently for the purchaser's purposes, the matter should be referred to the General Electric Company.



GE Industrial Systems