



## Vital 2 and Vital 3

Operating instruction

## General

Vital is based on a single-channel safety concept where several safety components (e.g. sensors) can be connected in series and supervised with only one safety module. A dynamic signal is sent from Vital through all connected components, and then back to Vital which evaluates the received signal. Since each safety component inverts the signal it is possible to detect short circuits, or failures, in a sensor. Vital 2 and Vital 3 are intended to be used together with Jokab Eden sensors, Tina components and Spot light beams or similar components. Vital 2 and 3 are both safety modules with two safe input functions and two output groups. The only difference between the two models lies in the input configuration.

## Eden

Eden – Adam and Eva is a non-contact safety sensor for use on interlocked gates, hatches etc. The dynamic signal from Vital is transmitted via Adam to Eva which modifies it and sends it back to Adam, which in turn sends it inverted to the next Eden in the safety loop. Since each Eden inverts the signal, different inputs on Vital 2/Vital 3 shall be used depending on if an even or an odd number of Eden sensors are connected in series.



## Tina

Tina is a product family from Jokab which converts the signal from sensors with contacts or OSSD-outputs to the dynamic safety loop. A large number of Tina components exist. A Tina 2A can for instance be used to invert the signal at a switch in order to make it possible to detect short circuits over the switch. Tina 10A is used to connect a Focus light beam/curtain to Vital 2/3.

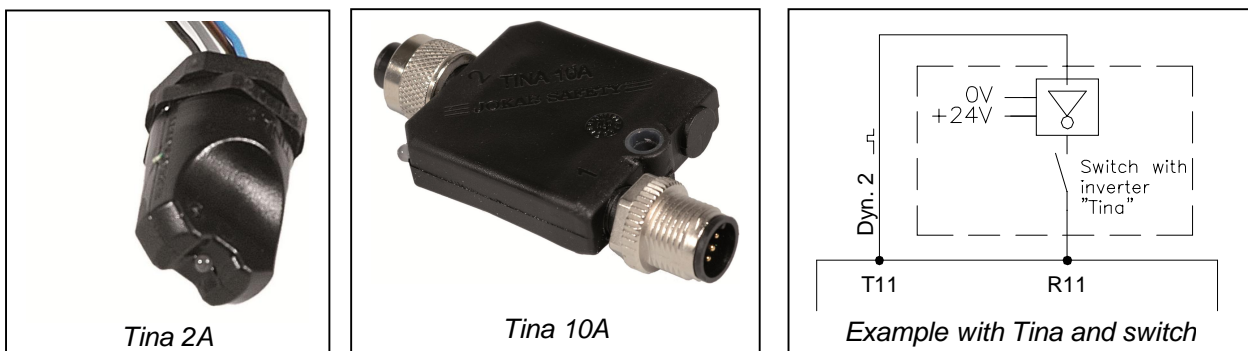

## Spot

Spot is a safety light beam which is available in two versions, Spot 10 for distances up to 10 m and Spot 35 for distances up to 35 m. The light beams can be mounted at different heights and be angled around a machine using special mirrors and brackets. For indication there are LED's on the transmitter and on the receiver which indicate "contact" between transmitter and receiver and safety status. The "contact" information is available via the light beam receiver connection cables.

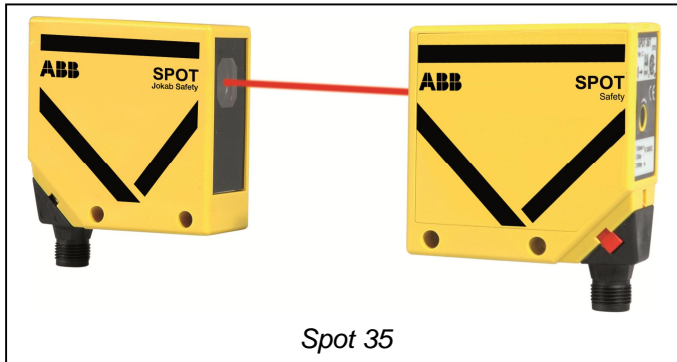

## Safety inputs Vital 2

Vital 2 has two single channel inputs for connection to dynamic sensors such as Jokab Eden sensors and Tina components. Each input function has two input terminals, one for an odd number of sensors and one for an even number of sensors.

## Safety inputs Vital 3

Input function 1 is a dual channel input for closing switches where one channel is a dynamic signal, and the other a static +24V signal. Input function 2 is a single channel input of the same type as in Vital 2.

### Connection of sensors

Maximum number of sensors that can be connected in series with 100m cable:

Eden	10
Spot 35	3
Spot 10	1
Tina	10

Maximum cable length without sensors for inputs using dynamic signals (depending on capacitance):

Example  $10 \times 0.75 \text{ mm}^2 = \text{approx. } 1000 \text{ meter}$

## Output groups

There are two groups of outputs:

Output group 1: Q1 and Q2.

Output group 2: Q11, Q12 and Q13. (Q13 is non-safe)

## Reset / Auto reset

There are two separate reset functions, Reset 1 and Reset 2. Depending on mode selection they work a bit differently (see Mode selection). They can be set to manual or automatic reset independently of each other with the inputs Auto reset 1 and Auto reset 2.

### Manual reset

For manual reset a pushbutton shall be connected to X1 (Reset 1) or X11 (Reset 2). Monitoring contacts of external devices shall be placed in series with the pushbutton. When manual reset is selected X4 (for Reset 1) and X14 (for Reset 2) works as reset indicator outputs to which a lamp can be connected.

### Auto reset

For auto reset, input X4 (Auto reset 1) or X14 (Auto reset 2) shall be connected to +24V. Monitoring contacts of external devices shall be placed between +24V and X1 (for Auto reset 1) or X11 (for Auto reset 2). If monitoring contacts are not used X1 and X11 shall be connected to +24V.

## Time delay

Output group 2 can be off-delayed by connecting the inputs 0.5s and 1.0s to +24V. The system is binary so connection of one of these inputs adds the corresponding time.

Connecting 0.5s = 0.5 sec. delay

Connecting 1.0s = 1.0 sec. delay

Connecting both 0.5s and 1.0s = 1.5 sec. delay

## Mode selection

Both Vital 2 and Vital 3 can be set to work in one of the three modes M1, M2 or M3. Selection of mode is done by connecting one of the terminals marked M1, M2 or M3 to +24V.

The following pictures show the logic for each mode of operation.

## Mode M1 - Separate function

Input function 1 controls output group 1, and input function 2 controls output group 2.

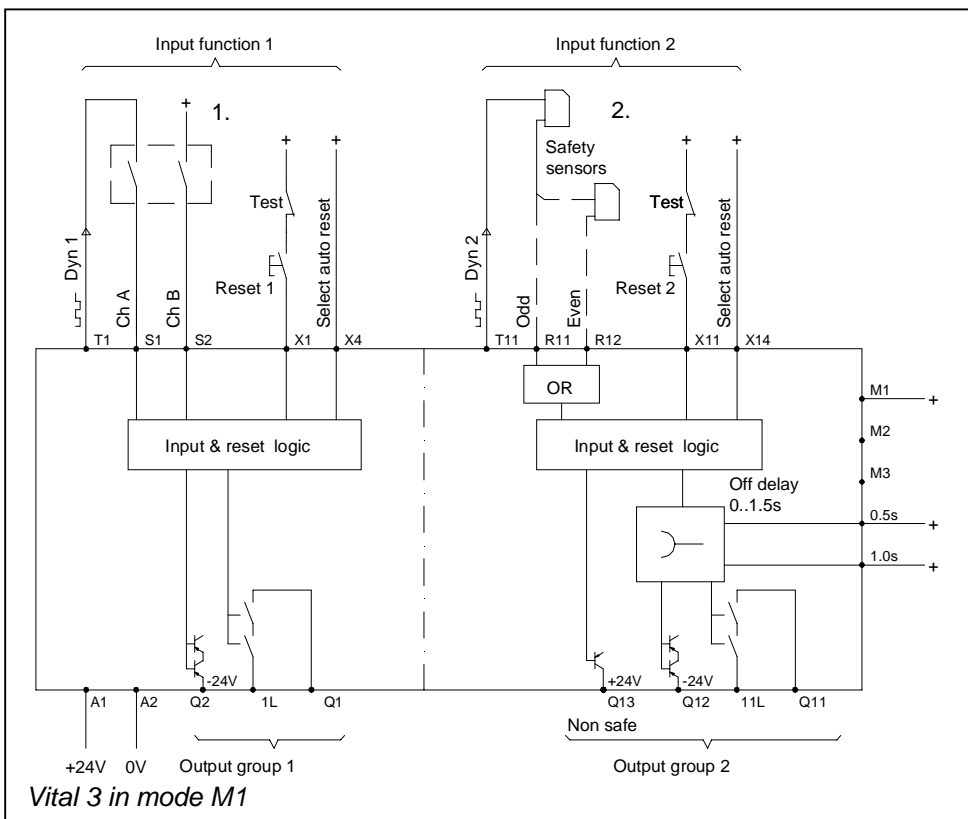
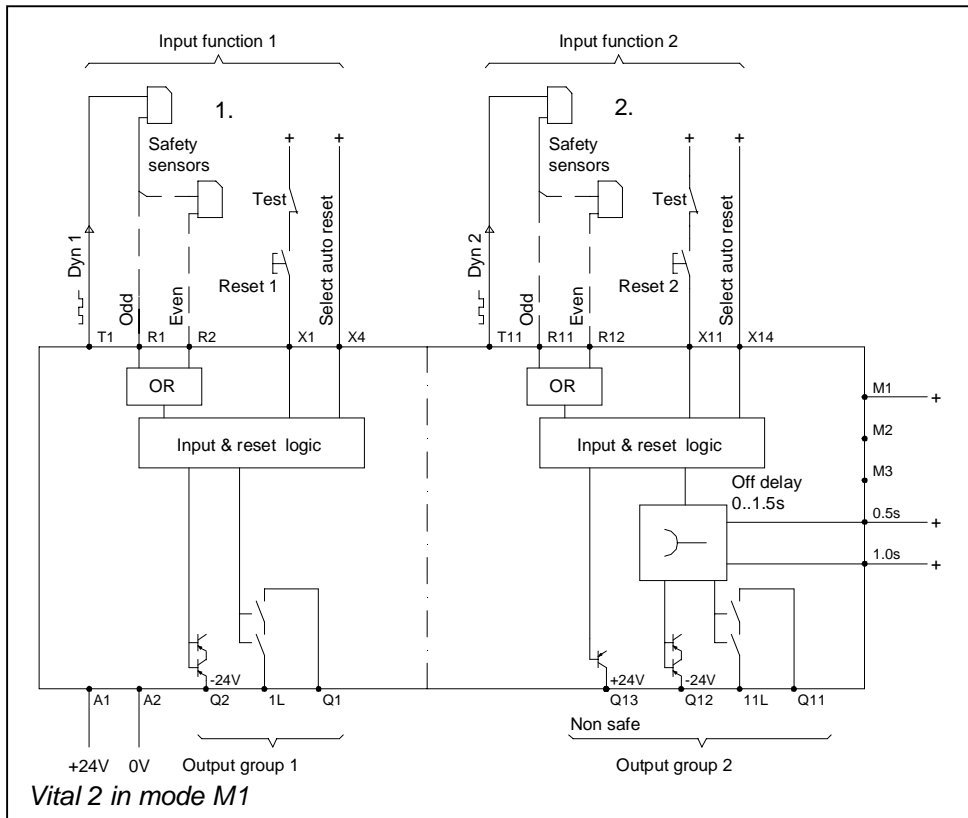

## Mode M2 - Input 1 master control function

Input function 1 stops all outputs, and input function 2 stops output group 2.

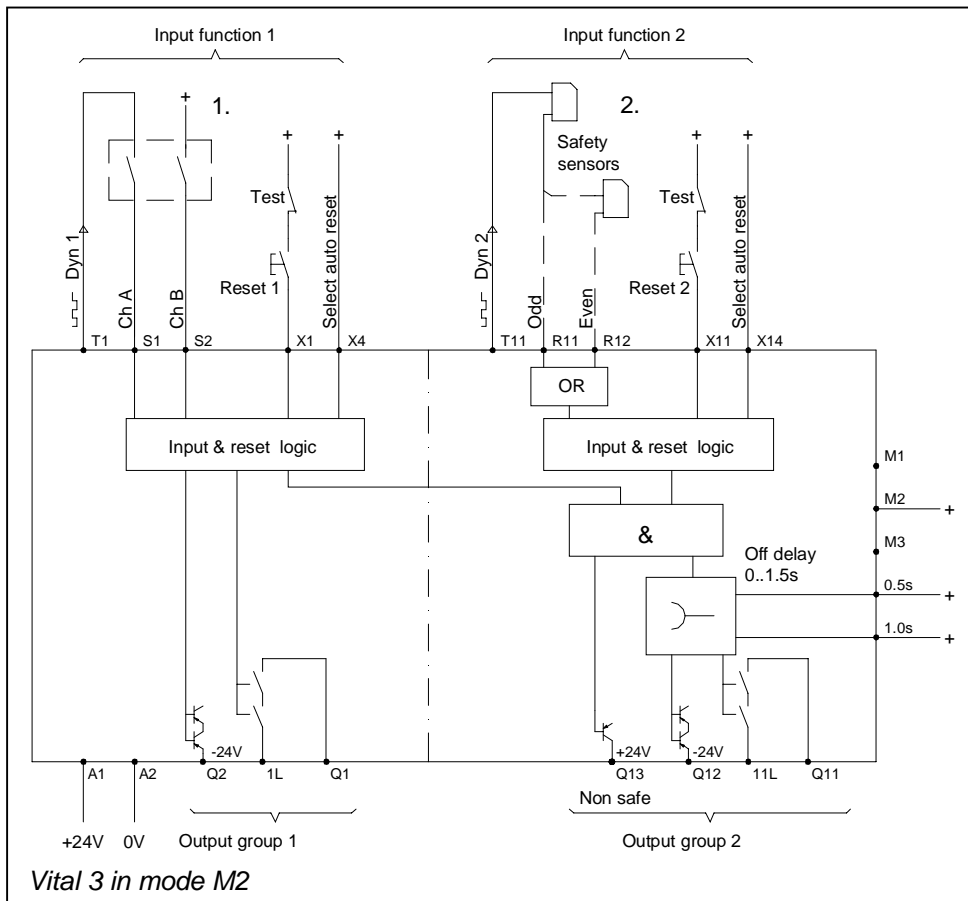
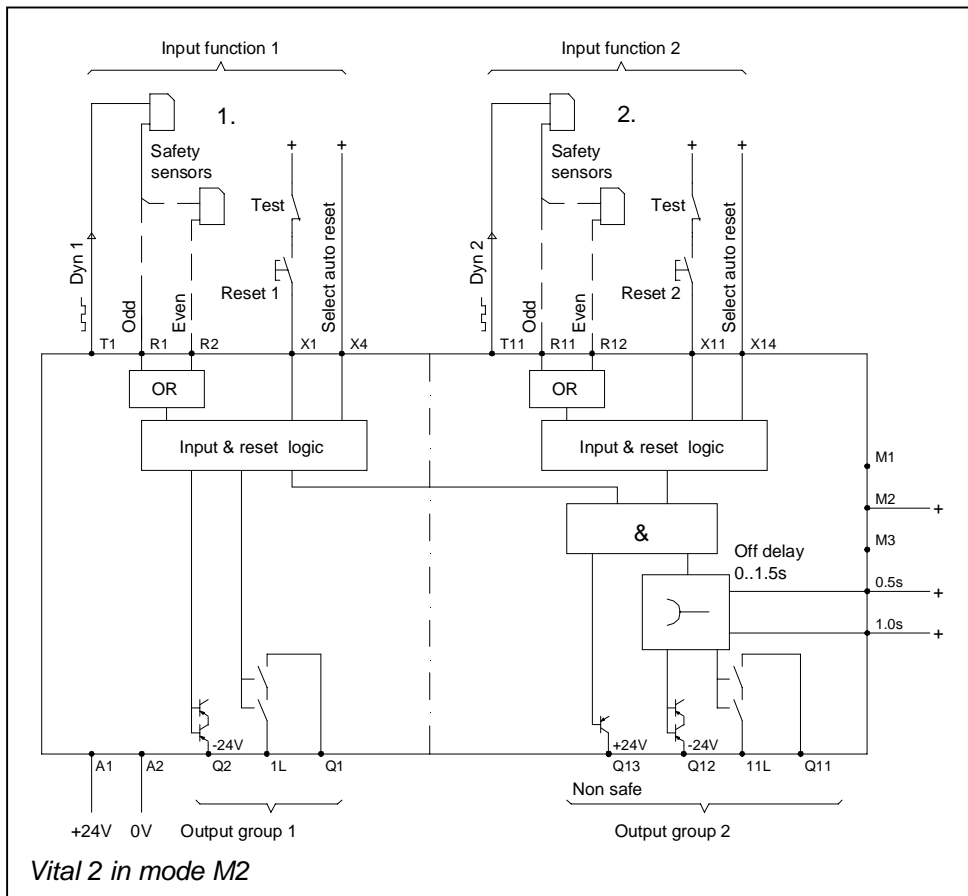

## Mode M3 - Parallel function

Input function 1 and Input function 2 works in parallel and controls all outputs. Reset/Auto reset 1 resets both input functions (Reset/Auto reset 2 is not used).

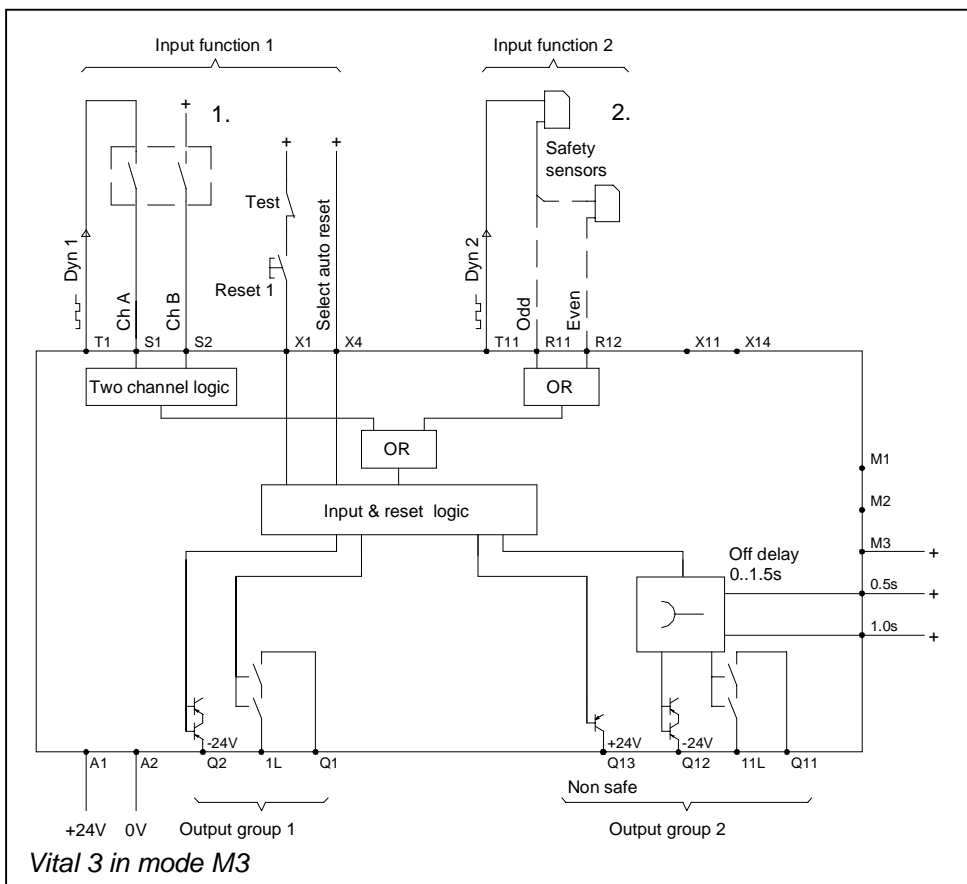
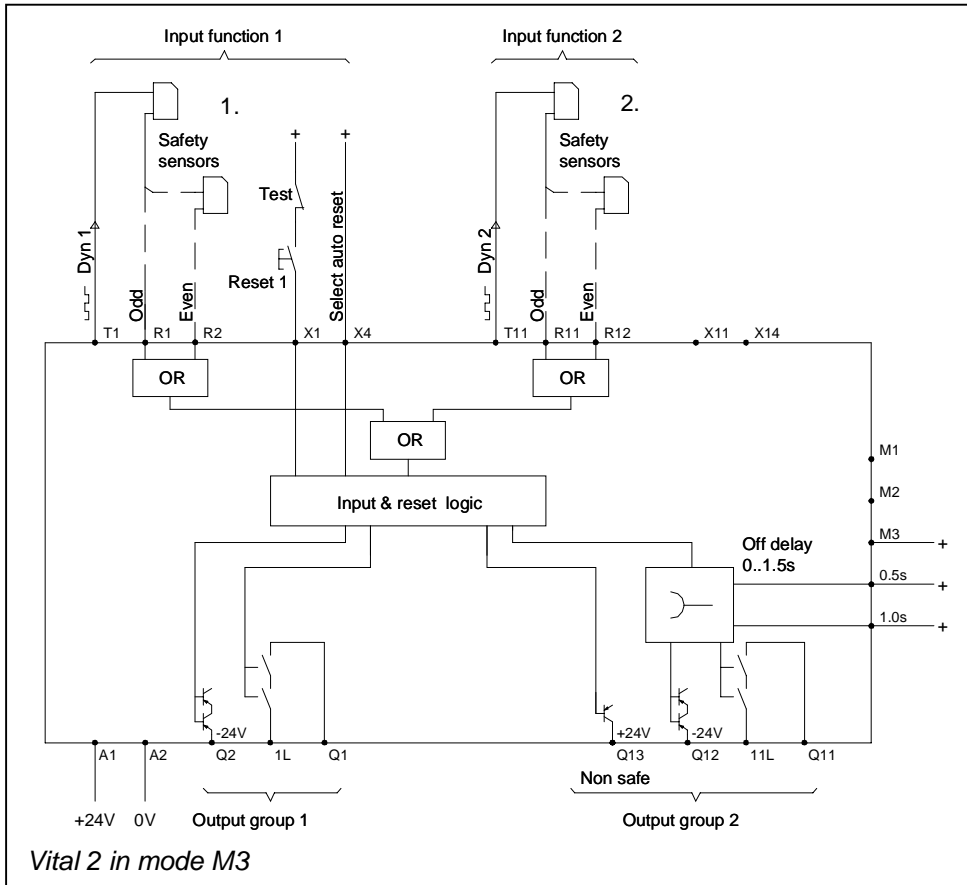

## Connection example

This example shows a Vital 2 in Mode M1 with 2 Eden sensors, a reset button and a Smile Tina emergency stop button.

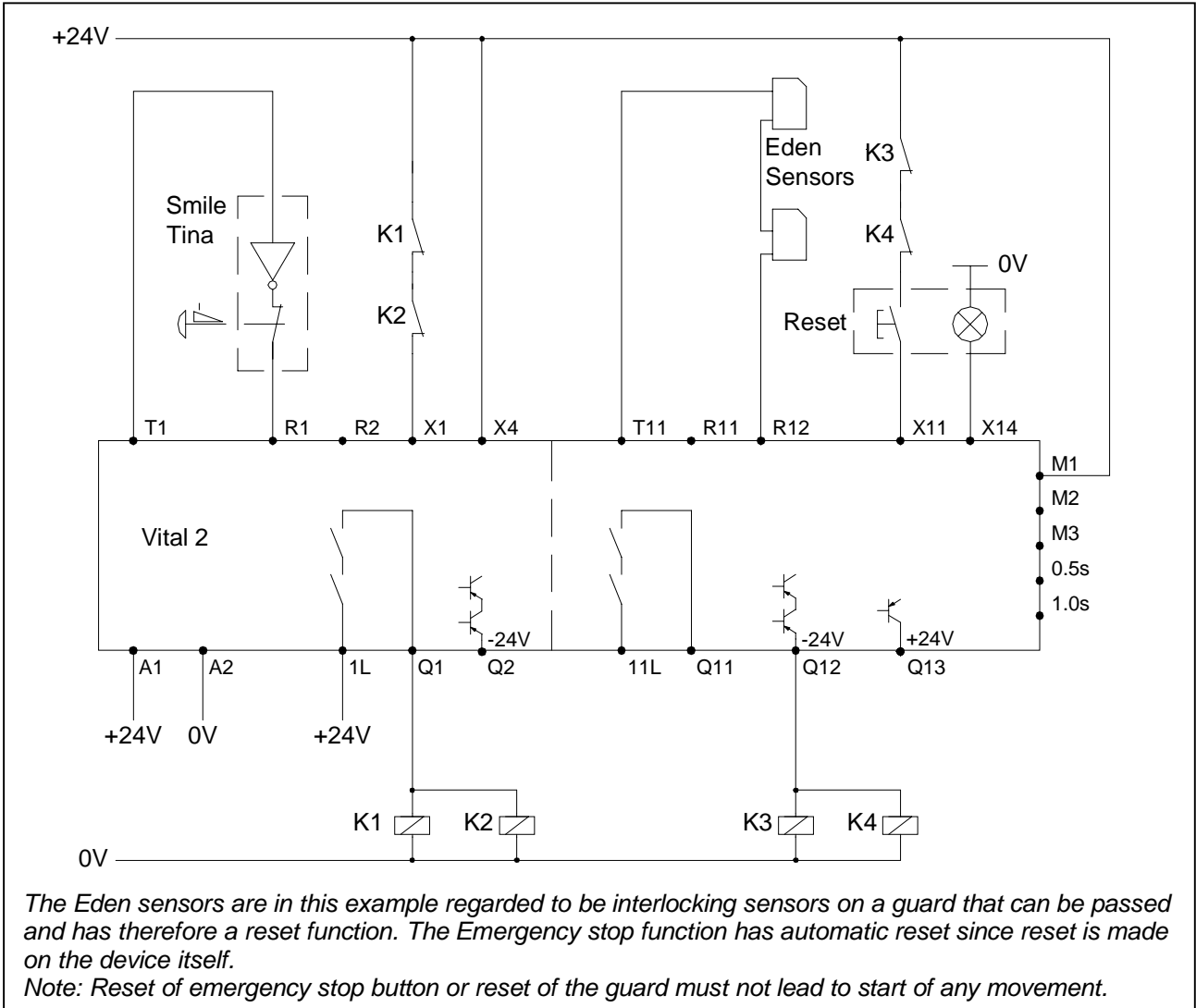



## Technical data

### Supply

Nominal voltage	24 VDC
Tolerance	+/-15%
Max interruption	20 ms
Recommended external fuse	6A

### Safety outputs

Solid state:	Q2, Q12
Output voltage (nominal):	- 24V
Output voltage by load:	> 22V at 800 mA / 24V supply voltage 23.3 V at 150 mA / 24V supply voltage
Max. load:	800 mA

Short circuit protection	Yes
Output – 0V	Normally (Not guaranteed)
Output – +24 V	

Relay output (Q1, Q11):	AC-1: 250V / 2A AC-15: 250V / 2A DC-1: 50V / 2A DC-13: 24V / 2A
-------------------------	--

### Non-safe output

Output voltage (nominal):	+24V
Max load	1 A

### General

Enclosure	45 x 84 x 118 mm (w x h x d)
-----------	------------------------------

Response time	
Relay output (Q1, Q11)	15 – 24 ms
Solid state safety outputs (Q2, Q12)	11 – 20 ms
Solid state non-failsafe output (Q13)	11 – 20 ms

Ambient air temperature:	-10°C - + 50°C
Temperature, transportation and storage:	- 25 - +50°C, <24h +70°C

Degree of protection:	
Enclosure:	IP 40, IEC 60 529
Terminals:	IP 20, IEC 60 529

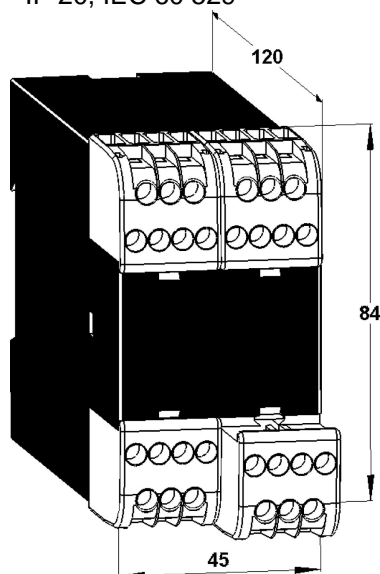

## Status messages and error codes

### Status messages

No:	Description
--	Power up
N	Run mode (1 = Mode M1, 2 = Mode M2, 3 = Mode M3)

### User faults

No:	Fault and possible reason.	Reset action
Er10*	T1 or T11 short circuited to foreign voltage.	Automatically reset
Er12*	Short circuit between two dynamic inputs (R1, R2, R11, R12, S1)	Automatically reset
Er13*	X4, X14 or Q13 short circuited to 0V or output Q2 or Q12 overloaded	Automatically reset, "K" button
Er15	Power supply below 18V	Autom. 3 min or "K" button
Er16	Power supply above 30V	Autom. 3 min or "K" button
Er90	Fault in mode selection. One of M1, M2 or M3 must be connected.	Automatically reset
Er91	Two channel fault, Input S1-S2 (only Vital 3)	Automatically reset

\*Combined with LED flashing for the affected I/O.

### I/O faults

No:	Fault and possible reason.	Reset action
Er40*	Error safety output Q2, Q12 - Q2, Q12 connected together or to other negative voltage or - Q2, Q12 has too high capacitive load.	"K" button.
Er41*	Error output Q2 or Q12. Overload or connected to foreign positive voltage.	"K" button.
Er42*	Error relay output. No answer from internal relay monitoring when output is off.	"K" button.
Er43*	Error relay output. (Self test of transistors)	Reboot
Er44*	Error relay output. Internal relay does not switch on.	"K" button.

\*Combined with LED flashing for the affected I/O.

### CPU faults

No:	Fault and possible reason.	Reset action
Er50	Input data difference between processor A and B Processor A and B reads an input differently. The fault is often caused by a bad sensor. Corresponding input LED flashes.	Reboot

Note: Reboot is made by power off-on.



## EC declaration of conformity

(according to 2006/42/EC, Annex 2A)

<b>We</b>	ABB AB Jokab Safety Varlabergsvägen 11 SE-434 39 Kungsbacka Sweden	declare that the safety components of ABB manufacture, with type designations and safety functions as listed below, are in conformity with the Directives 2006/42/EC 2004/108/EC 2006/95/EC
<b>Person authorised to compile the technical file</b>	Göran Svensson Jokab Safety AB Kanalvägen 17 SE-183 30 Täby Sweden	
<b>Product</b>	Logic unit to ensure safety functions	
<b>Type designation</b>	Vital 2, Vital 3	
<b>Used harmonized standards</b>	EN ISO 13849-1/EN 954-1, EN ISO 13849-2, EN 62061, EN 61496-1, EN 574, EN 692, EN 60204-1, EN 50178, EN 61000-6-2, EN 61000-6-4, EN 61000-4-	
<b>Other used standards and documents</b>	IEC/EN 61508-1..7	
<b>Notified Body</b>	TÜV-Rheinland Product Safety GMBH Am Grauen Stein 51105 Köln Germany  Nr. 0035	
<b>EC Type-Examination Certificate</b>	01/205/5304/13  Vital 2, 3 is an application of Pluto. The PLC-program is not covered by the certificate	

Jesper Kristensson  
PRU Manager  
Kungsbacka 2013-04-16