

# REM 54\_ Machine Terminal

Technical Reference Manual, General

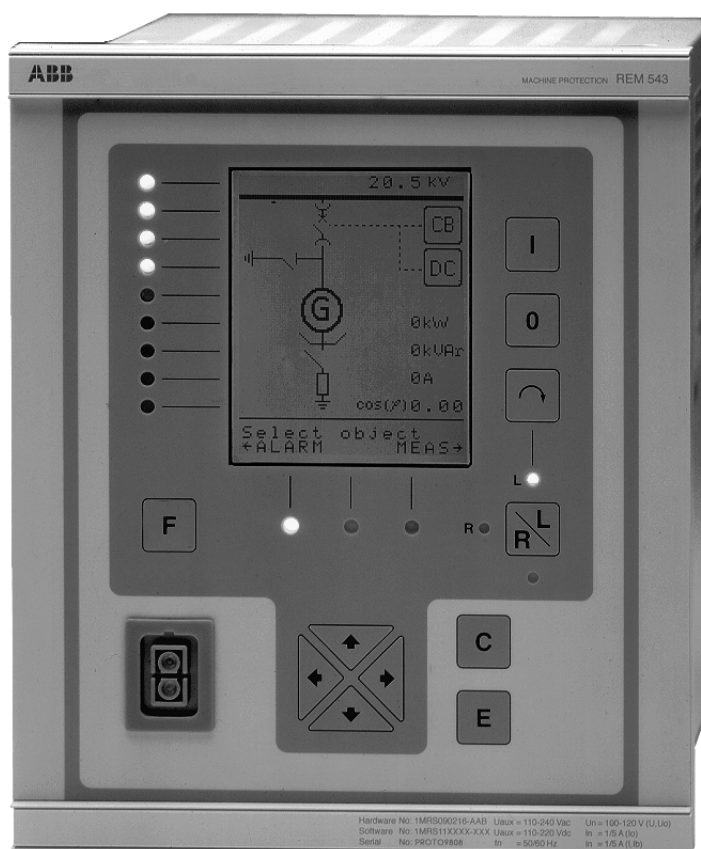

**ABB**



We reserve the right to change data without prior notice.

## Contents

<b>About this manual .....</b>	<b>6</b>
<b>1. Introduction .....</b>	<b>7</b>
1.1. General .....	7
1.2. Hardware versions .....	7
<b>2. Safety Information .....</b>	<b>16</b>
<b>3. Instructions .....</b>	<b>17</b>
3.1. Application .....	17
3.2. Requirements .....	18
3.3. Configuration .....	19
<b>4. Technical Description .....</b>	<b>20</b>
4.1. Functional description .....	20
4.1.1. Functions of the machine terminal .....	20
4.1.1.1. Protection functions .....	20
4.1.1.2. Measurement functions .....	21
4.1.1.3. Control functions .....	22
4.1.1.4. Condition monitoring functions .....	23
4.1.1.5. Communication .....	24
4.1.1.6. General functions .....	24
4.1.1.7. Standard functions .....	24
4.1.2. Configuration .....	26
4.1.2.1. Machine terminal configuration .....	26
4.1.2.2. MIMIC configuration .....	27
4.1.2.3. LON network configuration .....	29
4.1.2.4. Rated frequency .....	29
4.1.3. Parameters and events .....	29
4.1.4. Parameterization .....	29
4.1.4.1. Local parameterization .....	30
4.1.4.2. External parameterization .....	30
4.1.4.3. Storing of parameters and recorded data .....	30
4.1.5. Auxiliary voltage .....	31
4.1.5.1. Power supply versions .....	31
4.1.5.2. Low auxiliary voltage indication .....	32
4.1.5.3. Overtemperature indication .....	32
4.1.6. Analogue channels .....	32
4.1.6.1. Setting the rated values for the protected unit ...	36
4.1.6.2. Technical data of the measuring devices .....	36

---

4.1.6.3. Calculated analogue channels .....	39
4.1.7. Digital inputs .....	39
4.1.7.1. Filter time of a digital input .....	41
4.1.7.2. Inversion of a digital input .....	41
4.1.7.3. Pulse counters .....	42
4.1.7.4. Oscillation suppression .....	43
4.1.7.5. Attributes of a digital input for machine terminal configuration .....	43
4.1.8. Digital outputs .....	44
4.1.8.1. High-speed double-pole power outputs (HSPO) .....	45
4.1.8.2. Single-pole power outputs (PO) .....	46
4.1.8.3. Double-pole power outputs (PO) .....	47
4.1.8.4. Signal outputs (SO) .....	48
4.1.9. RTD/analogue inputs .....	48
4.1.9.1. Selection of input signal type .....	48
4.1.9.2. Selection of input signal range .....	49
4.1.9.3. Transducer supervision .....	50
4.1.9.4. Signal filtering .....	51
4.1.9.5. Input scaling/linearization .....	51
4.1.9.6. Transducer connections .....	52
4.1.9.7. Attributes of an RTD/analogue input for machine terminal configuration .....	54
4.1.9.8. RTD/analogue input configuration example .....	54
4.1.9.9. Self-supervision .....	55
4.1.9.10. Calibration .....	55
4.1.9.11. RTD temperature vs. resistance .....	56
4.1.10. Analogue outputs .....	57
4.1.10.1. Selection of analogue output range .....	57
4.1.10.2. Attributes of an analogue output for machine terminal configuration .....	57
4.1.10.3. Analogue output configuration example .....	58
4.1.11. Trip circuit supervision .....	59
4.1.11.1. Configuring the trip circuit supervision CMTCS_ .....	60
4.1.12. Self-supervision (IRF) .....	61
4.1.12.1. Fault indication .....	61
4.1.12.2. Fault codes .....	61
4.1.13. Serial communication .....	62
4.1.13.1. LON/SPA bus communication on the rear connector X3.3 .....	62
4.1.13.2. Front panel optical RS-232 connection for a PC .....	62
4.1.13.3. Communication parameters .....	62
4.1.13.4. Parallel communication support .....	63

---

4.1.13.5.	System structure .....	63
4.1.13.6.	LON inputs and outputs via a LON bus .....	64
4.1.14.	Display panel (MMI) .....	65
4.1.15.	Alarm LED indicators .....	67
4.1.15.1.	Non-latched alarm .....	67
4.1.15.2.	Latched alarm, steady LED .....	68
4.1.15.3.	Latched alarm, blinking LEDs .....	69
4.1.15.4.	Interlocking .....	69
4.2.	Design description .....	70
4.2.1.	Technical data .....	70
4.2.2.	Terminal diagram of REM 543 .....	75
4.2.3.	Terminal diagram of REM 545 .....	76
4.2.4.	Terminal diagram of the RTD/analogue module .....	77
4.2.5.	Definition of power direction .....	78
4.2.6.	Terminal connections .....	78
<b>5.</b>	<b>Service .....</b>	<b>82</b>
<b>6.</b>	<b>Ordering Information .....</b>	<b>83</b>
6.1.	Order number .....	83
6.2.	Hardware versions of REM 543 and REM 545 .....	84
6.3.	Software configuration .....	84
<b>7.</b>	<b>Revision History of REM 54_ .....</b>	<b>85</b>
7.1.	Revision identification .....	85
7.2.	Release 2.0 .....	85
7.2.1.	Changes and additions to earlier released revisions .....	85
7.2.2.	Configuration, setting and SA system tools .....	88
<b>8.</b>	<b>References .....</b>	<b>89</b>
<b>9.</b>	<b>Glossary .....</b>	<b>90</b>
<b>10.</b>	<b>Index .....</b>	<b>91</b>
<b>11.</b>	<b>Customer Feedback .....</b>	<b>95</b>

## About this manual

This document, Technical Reference Manual for REM 54\_, provides a general technical description of the machine terminals REM 543 and REM 545. The version D of the Technical Reference Manual complies with REM 54\_ machine terminals of the Release 2.0. For information about the changes and additions included in REM 54\_ revisions of the Release 2.0 compared to the Release 1.5, please refer to section “Revision History of REM 54\_” on page 85.

For detailed information about the separate protection and other functions listed in section 4.1.1., refer to the version 2.2 or later of the CD-ROM “Technical Descriptions of Functions”.

## Revision history

Version B/3.5.1999:

- Text added to the table in section “Standard functions”: INDRESET; Resetting of operation indicators, latched output signals, registers and waveforms *i.e. the disturbance recorder*
- Section “Technical data”, tables “Signal outputs” and “Power outputs”: Rated voltage → *Max system voltage*
- Section “Ordering Information” changed
- Section “Libraries” removed
- Section “Application” changed
- Text modified in sections “Protection functions”, “Control functions”, “Technical data of the measuring devices”, “Software configuration” and “Terminal connections”
- Text added to sections “Calculated analogue channels” and “Fault codes”
- Text modified in section “Technical data”, tables 1, 2, 6, 7 and 8

Version C/30.06.1999:

- Text added/changed in sections “Safety Information”, “Application”, “Configuration”, “Self-supervision”, “Fault codes”, “Calculated analogue channels”, “Terminal connections”, “Service” and “Software configuration”
- Index added
- Functions added to section “Standard functions”

Version D/07.04.2000:

- Functions added to section “Functions of the machine terminal”
- Sections “General functions”, “Parameters and events”, “Single-pole power outputs (PO)”, “Double-pole power outputs (PO)”, “RTD/analogue inputs”, “Analogue outputs”, “Communication parameters”, “Terminal diagram of REM 545”, “Terminal diagram of the RTD/analogue module” and “Revision History of REM 54\_” added
- Text added/changed throughout the manual
- Terminal diagram of REM 543 modified
- Index updated

Version D/11.05.2000:

- Corrections: gas ~~density~~ pressure monitoring (CMGAS1, CMGAS3), Figure 6.1.-1 on page 83

# 1. Introduction

## 1.1. General

The REM 54\_ rotating machine terminal is part of the PYRAMID<sup>®</sup> substation automation system for Distribution Automation and extends the functionality and flexibility of the concept further. This is possible due to the modern technology applied both in hardware and software solutions.

Increased performance is achieved by utilizing the multiprocessor architecture. Digital signal processing combined with a powerful CPU and distributed I/O handling facilitates parallel operations and improves response times and accuracy. The MMI including an LCD display with different views makes the local use of the REM 54\_ rotating machine terminal safe and easy. The MMI instructs the user how to proceed.



Fig. 1.1.-1 REM 54\_ rotating machine terminal

## 1.2. Hardware versions

The REM 54\_ rotating machine terminal contains several hardware versions (see tables below). Depending on the number of I/Os available, the product is called REM 543 or REM 545.

**Table 1.2.-1 Hardware versions of REM 543**

HW modules	Order number											
	REM543B_212AAAA	REM543B_212CAAA	REM543B_212AABA	REM543B_212CABA	REM543B_212AABB	REM543B_212AABB	REM543A_213AAAA	REM543A_213CAAA	REM543A_213AABA	REM543A_213CABA	REM543A_213AABB	REM543A_213AABB
<b>Analogue interface</b>												
Sensor channels (current/ voltage)			9	9		9			9	9		9
Current trafo 1/5 A	4	4	4	4	4	4	4	4	4	4	4	4
Current trafo 0.2/1 A	1	1	1	1	1	1	1	1	1	1	1	1
Voltage trafo 100 V	4	4	4	4	4	4	4	4	4	4	4	4
<b>Main processor boards</b>												
CPU module	1	1	1	1	1	1	1	1	1	1	1	1
<b>Power supply boards</b>												
Type 1: 80...265 Vdc/Vac	1		1		1	1	1		1		1	1
Type 1: 18...80 Vdc		1		1				1		1		
Type 2: 80...265 Vdc/Vac												
Type 2: 18...80 Vdc												
<b>Digital I/O boards</b>												
Type 1: threshold voltage 80 Vdc	1		1		1	1	1		1		1	1
Type 1: threshold voltage 18 Vdc		1		1				1		1		
Type 2: threshold voltage 80 Vdc												
Type 2: threshold voltage 18 Vdc												
<b>Analogue I/O board</b>												
RTD/analogue module							1	1	1	1	1	1
<b>Display boards</b>												
Graphic MMI display, fixed	1	1	1	1			1	1	1	1		
Graphic MMI display, external					1	1					1	1
<b>Mechanic</b>												
1/2 enclosure	1	1	1	1	1	1	1	1	1	1	1	1
<b>Digital inputs</b>												
	15						15					
<b>Power outputs, single pole</b>												
	0						0					
<b>Power outputs, double pole</b>												
	5						5					
<b>Signal outputs (NO)</b>												
	2						2					
<b>Signal outputs (NO/NC)</b>												
	5						5					
<b>Supervised trip circuits</b>												
	2						2					
<b>IRF outputs</b>												
	1						1					
<b>RTD/analogue inputs</b>												
	0						8					
<b>Analogue outputs</b>												
	0						4					

Table 1.2.-2 Hardware versions of REM 543 (contd)

HW modules	Order number											
	REM543B_214AAAA	REM543B_214CAAA	REM543B_214AABA	REM543B_214CABA	REM543B_214AAAB	REM543B_214AABB	REM543A_215AAAA	REM543A_215CAAA	REM543A_215AABA	REM543A_215CABA	REM543A_215AAAB	REM543A_215AABB
<b>Analogue interface</b>												
Sensor channels (current/ voltage)			9	9		9			9	9		9
Current trafo 1/5 A	6	6	6	6	6	6	6	6	6	6	6	6
Current trafo 0.2/1 A												
Voltage trafo 100 V	3	3	3	3	3	3	3	3	3	3	3	3
<b>Main processor boards</b>												
CPU module	1	1	1	1	1	1	1	1	1	1	1	1
<b>Power supply boards</b>												
Type 1: 80...265 Vdc/Vac	1		1		1	1	1		1		1	1
Type 1: 18...80 Vdc		1		1				1		1		
Type 2: 80...265 Vdc/Vac												
Type 2: 18...80 Vdc												
<b>Digital I/O boards</b>												
Type 1: threshold voltage 80 Vdc	1		1		1	1	1		1		1	1
Type 1: threshold voltage 18 Vdc		1		1				1		1		
Type 2: threshold voltage 80 Vdc												
Type 2: threshold voltage 18 Vdc												
<b>Analogue I/O board</b>												
RTD/analogue module							1	1	1	1	1	1
<b>Display boards</b>												
Graphic MMI display, fixed	1	1	1	1			1	1	1	1		
Graphic MMI display, external					1	1					1	1
<b>Mechanic</b>												
1/2 enclosure	1	1	1	1	1	1	1	1	1	1	1	1
<b>Digital inputs</b>												
	15						15					
<b>Power outputs, single pole</b>												
	0						0					
<b>Power outputs, double pole</b>												
	5						5					
<b>Signal outputs (NO)</b>												
	2						2					
<b>Signal outputs (NO/NC)</b>												
	5						5					
<b>Supervised trip circuits</b>												
	2						2					
<b>IRF outputs</b>												
	1						1					
<b>RTD/analogue inputs</b>												
	0						8					
<b>Analogue outputs</b>												
	0						4					

**Table 1.2.-3 Hardware versions of REM 543 (contd)**

HW modules	Order number											
	REM543B_216AAAA	REM543B_216CAAA	REM543B_216AABA	REM543B_216CABA	REM543B_216AAAB	REM543B_216AABB	REM543A_217AAAA	REM543A_217CAAA	REM543A_217AABA	REM543A_217CABA	REM543A_217AAAB	REM543A_217AABB
<b>Analogue interface</b>												
Sensor channels (current/ voltage)			9	9		9			9	9		9
Current trafo 1/5 A	7	7	7	7	7	7	7	7	7	7	7	7
Current trafo 0.2/1 A												
Voltage trafo 100 V	2	2	2	2	2	2	2	2	2	2	2	2
<b>Main processor boards</b>												
CPU module	1	1	1	1	1	1	1	1	1	1	1	1
<b>Power supply boards</b>												
Type 1: 80...265 Vdc/Vac	1		1		1	1	1		1		1	1
Type 1: 18...80 Vdc		1		1				1		1		
Type 2: 80...265 Vdc/Vac												
Type 2: 18...80 Vdc												
<b>Digital I/O boards</b>												
Type 1: threshold voltage 80 Vdc	1		1		1	1	1		1		1	1
Type 1: threshold voltage 18 Vdc		1		1				1		1		
Type 2: threshold voltage 80 Vdc												
Type 2: threshold voltage 18 Vdc												
<b>Analogue I/O board</b>												
RTD/analogue module							1	1	1	1	1	1
<b>Display boards</b>												
Graphic MMI display, fixed	1	1	1	1			1	1	1	1		
Graphic MMI display, external					1	1					1	1
<b>Mechanic</b>												
1/2 enclosure	1	1	1	1	1	1	1	1	1	1	1	1
<b>Digital inputs</b>												
	15						15					
<b>Power outputs, single pole</b>												
	0						0					
<b>Power outputs, double pole</b>												
	5						5					
<b>Signal outputs (NO)</b>												
	2						2					
<b>Signal outputs (NO/NC)</b>												
	5						5					
<b>Supervised trip circuits</b>												
	2						2					
<b>IRF outputs</b>												
	1						1					
<b>RTD/analogue inputs</b>												
	0						8					
<b>Analogue outputs</b>												
	0						4					

**Table 1.2.-4 Hardware versions of REM 543 (contd)**

HW modules	Order number											
	REM543B_218AAAA	REM543B_218CAAA	REM543B_218AABA	REM543B_218CABA	REM543B_218AAAB	REM543B_218AABB	REM543A_219AAAA	REM543A_219CAAA	REM543A_219AABA	REM543A_219CABA	REM543A_219AAAB	REM543A_219AABB
<b>Analogue interface</b>												
Sensor channels (current/ voltage)			9	9		9			9	9		9
Current trafo 1/5 A	8	8	8	8	8	8	8	8	8	8	8	8
Current trafo 0.2/1 A												
Voltage trafo 100 V	1	1	1	1	1	1	1	1	1	1	1	1
<b>Main processor boards</b>												
CPU module	1	1	1	1	1	1	1	1	1	1	1	1
<b>Power supply boards</b>												
Type 1: 80...265 Vdc/Vac	1		1		1	1	1		1		1	1
Type 1: 18...80 Vdc		1		1				1		1		
Type 2: 80...265 Vdc/Vac												
Type 2: 18...80 Vdc												
<b>Digital I/O boards</b>												
Type 1: threshold voltage 80 Vdc	1		1		1	1	1		1		1	1
Type 1: threshold voltage 18 Vdc		1		1				1		1		
Type 2: threshold voltage 80 Vdc												
Type 2: threshold voltage 18 Vdc												
<b>Analogue I/O board</b>												
RTD/analogue module							1	1	1	1	1	1
<b>Display boards</b>												
Graphic MMI display, fixed	1	1	1	1			1	1	1	1		
Graphic MMI display, external					1	1					1	1
<b>Mechanic</b>												
1/2 enclosure	1	1	1	1	1	1	1	1	1	1	1	1
<b>Digital inputs</b>												
	15						15					
<b>Power outputs, single pole</b>												
	0						0					
<b>Power outputs, double pole</b>												
	5						5					
<b>Signal outputs (NO)</b>												
	2						2					
<b>Signal outputs (NO/NC)</b>												
	5						5					
<b>Supervised trip circuits</b>												
	2						2					
<b>IRF outputs</b>												
	1						1					
<b>RTD/analogue inputs</b>												
	0						8					
<b>Analogue outputs</b>												
	0						4					

**Table 1.2.-5 Hardware versions of REM 545**

HW modules	Order number											
	REM545A_222AAAA	REM545A_222CAAA	REM545A_222AABA	REM545A_222CABA	REM545A_222AABB	REM545A_222AABB	REM545A_223AAAA	REM545A_223CAAA	REM545A_223AABA	REM545A_223CABA	REM545A_223AABB	REM545A_223AABB
<b>Analogue interface</b>												
Sensor channels (current/ voltage)			9	9		9			9	9		9
Current trafo 1/5 A	4	4	4	4	4	4	4	4	4	4	4	4
Current trafo 0.2/1 A	1	1	1	1	1	1	1	1	1	1	1	1
Voltage trafo 100 V	4	4	4	4	4	4	4	4	4	4	4	4
<b>Main processor boards</b>												
CPU module	1	1	1	1	1	1	1	1	1	1	1	1
<b>Power supply boards</b>												
Type 1: 80...265 Vdc/Vac	1		1		1	1	1		1		1	1
Type 1: 18...80 Vdc		1		1				1		1		
Type 2: 80...265 Vdc/Vac												
Type 2: 18...80 Vdc												
<b>Digital I/O boards</b>												
Type 1: threshold voltage 80 Vdc	1		1		1	1	1		1		1	1
Type 1: threshold voltage 18 Vdc		1		1				1		1		
Type 2: threshold voltage 80 Vdc	1		1		1	1	1		1		1	1
Type 2: threshold voltage 18 Vdc		1		1				1		1		
<b>Analogue I/O board</b>												
RTD/analogue module							1	1	1	1	1	1
<b>Display boards</b>												
Graphic MMI display, fixed	1	1	1	1			1	1	1	1		
Graphic MMI display, external					1	1					1	1
<b>Mechanic</b>												
1/2 enclosure	1	1	1	1	1	1	1	1	1	1	1	1
<b>Digital inputs</b>												
	25						25					
<b>Power outputs, single pole</b>												
	2						2					
<b>Power outputs, double pole</b>												
	9						9					
<b>Signal outputs (NO)</b>												
	2						2					
<b>Signal outputs (NO/NC)</b>												
	5						5					
<b>Supervised trip circuits</b>												
	2						2					
<b>IRF outputs</b>												
	1						1					
<b>RTD/analogue inputs</b>												
	0						8					
<b>Analogue outputs</b>												
	0						4					

Table 1.2.-6 Hardware versions of REM 545 (cotnd)

HW modules	Order number											
	REM545A_224AAAA	REM545A_224CAAA	REM545A_224AABA	REM545A_224CABA	REM545A_224AAAB	REM545A_224AABB	REM545A_225AAAA	REM545A_225CAAA	REM545A_225AABA	REM545A_225CABA	REM545A_225AAAB	REM545A_225AABB
<b>Analogue interface</b>												
Sensor channels (current/ voltage)			9	9		9			9	9		9
Current trafo 1/5 A	6	6	6	6	6	6	6	6	6	6	6	6
Current trafo 0.2/1 A												
Voltage trafo 100 V	3	3	3	3	3	3	3	3	3	3	3	3
<b>Main processor boards</b>												
CPU module	1	1	1	1	1	1	1	1	1	1	1	1
<b>Power supply boards</b>												
Type 1: 80...265 Vdc/Vac	1		1		1	1	1		1		1	1
Type 1: 18...80 Vdc		1		1				1		1		
Type 2: 80...265 Vdc/Vac												
Type 2: 18...80 Vdc												
<b>Digital I/O boards</b>												
Type 1: threshold voltage 80 Vdc	1		1		1	1	1		1		1	1
Type 1: threshold voltage 18 Vdc		1		1				1		1		
Type 2: threshold voltage 80 Vdc	1		1		1	1	1		1		1	1
Type 2: threshold voltage 18 Vdc		1		1				1		1		
<b>Analogue I/O board</b>												
RTD/analogue module							1	1	1	1	1	1
<b>Display boards</b>												
Graphic MMI display, fixed	1	1	1	1			1	1	1	1		
Graphic MMI display, external					1	1					1	1
<b>Mechanic</b>												
1/2 enclosure	1	1	1	1	1	1	1	1	1	1	1	1
<b>Digital inputs</b>												
	25						25					
<b>Power outputs, single pole</b>												
	2						2					
<b>Power outputs, double pole</b>												
	9						9					
<b>Signal outputs (NO)</b>												
	2						2					
<b>Signal outputs (NO/NC)</b>												
	5						5					
<b>Supervised trip circuits</b>												
	2						2					
<b>IRF outputs</b>												
	1						1					
<b>RTD/analogue inputs</b>												
	0						8					
<b>Analogue outputs</b>												
	0						4					

**Table 1.2.-7 Hardware versions of REM 545 (cotnd)**







HW modules	Order number											
	REM545A_226AAAA	REM545A_226CAAA	REM545A_226AABA	REM545A_226CABA	REM545A_226AAAB	REM545A_226AABB	REM545A_227AAAA	REM545A_227CAAA	REM545A_227AABA	REM545A_227CABA	REM545A_227AAAB	REM545A_227AABB
<b>Analogue interface</b>												
Sensor channels (current/ voltage)			9	9		9			9	9		9
Current trafo 1/5 A	7	7	7	7	7	7	7	7	7	7	7	7
Current trafo 0.2/1 A												
Voltage trafo 100 V	2	2	2	2	2	2	2	2	2	2	2	2
<b>Main processor boards</b>												
CPU module	1	1	1	1	1	1	1	1	1	1	1	1
<b>Power supply boards</b>												
Type 1: 80...265 Vdc/Vac	1		1		1	1	1		1		1	1
Type 1: 18...80 Vdc		1		1				1		1		
Type 2: 80...265 Vdc/Vac												
Type 2: 18...80 Vdc												
<b>Digital I/O boards</b>												
Type 1: threshold voltage 80 Vdc	1		1		1	1	1		1		1	1
Type 1: threshold voltage 18 Vdc		1		1				1		1		
Type 2: threshold voltage 80 Vdc	1		1		1	1	1		1		1	1
Type 2: threshold voltage 18 Vdc		1		1				1		1		
<b>Analogue I/O board</b>												
RTD/analogue module							1	1	1	1	1	1
<b>Display boards</b>												
Graphic MMI display, fixed	1	1	1	1			1	1	1	1		
Graphic MMI display, external					1	1					1	1
<b>Mechanic</b>												
1/2 enclosure	1	1	1	1	1	1	1	1	1	1	1	1
<b>Digital inputs</b>												
	25						25					
<b>Power outputs, single pole</b>												
	2						2					
<b>Power outputs, double pole</b>												
	9						9					
<b>Signal outputs (NO)</b>												
	2						2					
<b>Signal outputs (NO/NC)</b>												
	5						5					
<b>Supervised trip circuits</b>												
	2						2					
<b>IRF outputs</b>												
	1						1					
<b>RTD/analogue inputs</b>												
	0						8					
<b>Analogue outputs</b>												
	0						4					

Table 1.2.-8 Hardware versions of REM 545 (cotnd)

HW modules	Order number											
	REM545A_228AAAA	REM545A_228CAAA	REM545A_228AABA	REM545A_228CABA	REM545A_228AAAB	REM545A_228AABB	REM545A_229AAAA	REM545A_229CAAA	REM545A_229AABA	REM545A_229CABA	REM545A_229AAAB	REM545A_229AABB
<b>Analogue interface</b>												
Sensor channels (current/ voltage)			9	9		9			9	9		9
Current trafo 1/5 A	8	8	8	8	8	8	8	8	8	8	8	8
Current trafo 0.2/1 A												
Voltage trafo 100 V	1	1	1	1	1	1	1	1	1	1	1	1
<b>Main processor boards</b>												
CPU module	1	1	1	1	1	1	1	1	1	1	1	1
<b>Power supply boards</b>												
Type 1: 80...265 Vdc/Vac	1		1		1	1	1		1		1	1
Type 1: 18...80 Vdc		1		1				1		1		
Type 2: 80...265 Vdc/Vac												
Type 2: 18...80 Vdc												
<b>Digital I/O boards</b>												
Type 1: threshold voltage 80 Vdc	1		1		1	1	1		1		1	1
Type 1: threshold voltage 18 Vdc		1		1				1		1		
Type 2: threshold voltage 80 Vdc	1		1		1	1	1		1		1	1
Type 2: threshold voltage 18 Vdc		1		1				1		1		
<b>Analogue I/O board</b>												
RTD/analogue module							1	1	1	1	1	1
<b>Display boards</b>												
Graphic MMI display, fixed	1	1	1	1			1	1	1	1		
Graphic MMI display, external					1	1					1	1
<b>Mechanic</b>												
1/2 enclosure	1	1	1	1	1	1	1	1	1	1	1	1
<b>Digital inputs</b>												
	25						25					
<b>Power outputs, single pole</b>												
	2						2					
<b>Power outputs, double pole</b>												
	9						9					
<b>Signal outputs (NO)</b>												
	2						2					
<b>Signal outputs (NO/NC)</b>												
	5						5					
<b>Supervised trip circuits</b>												
	2						2					
<b>IRF outputs</b>												
	1						1					
<b>RTD/analogue inputs</b>												
	0						8					
<b>Analogue outputs</b>												
	0						4					

---

## 2. Safety Information

	Dangerous voltages can occur on the connectors, even though the auxiliary voltage is disconnected
	National and local electrical safety regulations must always be followed
	The products contain components that are sensitive to electrostatic discharge
	The frame of the device has to be carefully earthed
	Only a competent electrician is allowed to carry out the electrical installation
	Non-observance can result in death, personal injury or substantial property damage
	Breaking the sealing tape on the rear panel of the device will result in loss of warranty, and a proper function of the product is no longer guaranteed

## 3. Instructions

### 3.1. Application

The REM 54\_ rotating machine terminals (referred to as “machine terminals” further on) are designed to be used as the main protection system of generator and generator-transformer units in small and medium-power diesel, hydroelectric and steam power plants, etc. The protection of large and/or important MV synchronous and asynchronous motors used e.g. in pumps, mills and crushers during start-up and normal run forms another application area.

The functionality available for REM 54\_ machine terminals depends on the selected functionality level (refer to section “Ordering Information” on page 83) and is also tied to the hardware configuration. The desired functions can be activated from a wide range of protection, control, measurement, condition monitoring, general and communication functions within the scope of I/O connections, considering the total CPU load. Compared to the traditional use of separate products, the combination of desired functions provides cost-effective solutions and, together with the relay configuration (IEC 61131 standard), allows the REM 54\_ machine terminals to be easily adapted to different kinds of applications.

By means of the graphic MMI display, the control functions in the machine terminal indicate the status of disconnectors or circuit breakers locally. Further, the machine terminal allows status information from the circuit breakers and the disconnectors to be transmitted to the remote control system. Controllable objects, such as CBs, can be opened and closed over the remote control system. Status information and control signals are transmitted over the serial bus. Local control is also possible via the push-buttons on the front panel of the machine terminal.

The protection functions of REM 54\_ are designed for selective short-circuit and earth-fault protection of rotating machines. Further, unlike most other power system components, rotating machines also need protection against abnormal operating conditions such as overcurrent, unbalanced load, overtemperature, overvoltage, over- and underexcitation, underimpedance, over- and underfrequency and generator motoring. Furthermore, stall protection and cumulative start-up counter are provided for motor protection start-up supervision.

The REM 54\_ terminal measures phase currents, phase-to-phase or phase-to-earth voltages, neutral current, residual voltage, frequency and power factors. Active and reactive power is calculated from measured currents and voltages. Energy can be calculated on the basis of the measured power. The measured values can be indicated locally and remotely as scaled primary values.

In addition to protection, measurement, control, condition monitoring and general functions, the machine terminals are provided with a large amount of PLC functions allowing several automation and sequence logic functions needed for substation automation to be integrated into one unit. The data communication properties include SPA bus or LON<sup>®1</sup> bus communication with higher-level equipment. Further, LON communication, together with PLC functions, minimizes the need for hardwiring between the machine terminals.

---

1. LON is a trademark of Echelon Corporation registered in the United States and other countries.

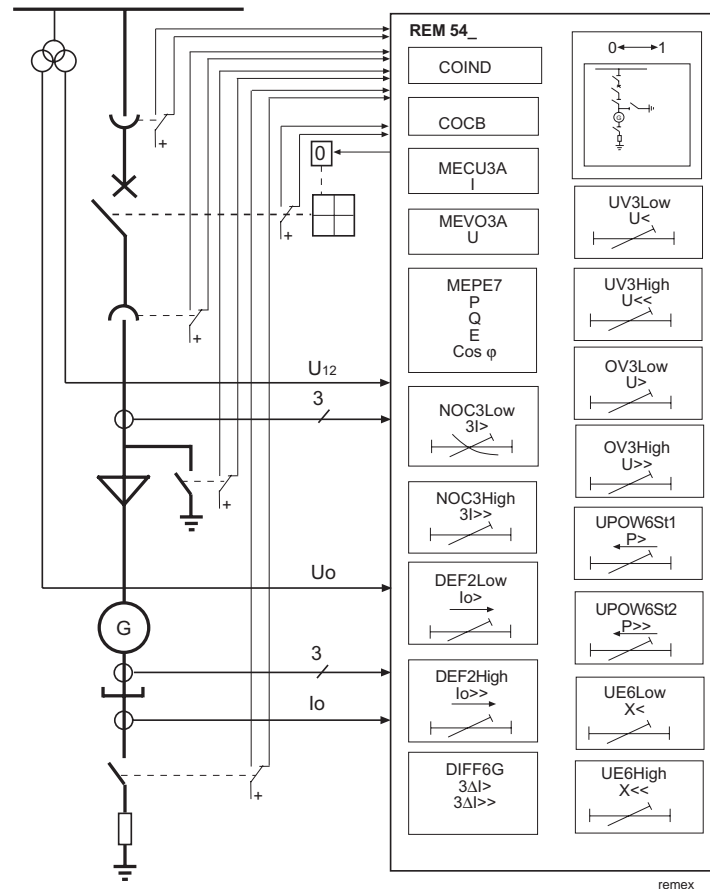

Fig. 3.1.-1 Basic functions of the integrated machine terminal REM 54\_

### 3.2.

#### Requirements

If the environmental conditions differ from those specified in section “Technical data”, as to temperature and humidity, or if the atmosphere around the machine terminal contains chemically active gases or dust, the terminal should be visually inspected in association with the secondary testing. The visual inspection should focus on:

- Signs of mechanical damage to the machine terminal case and terminals
- Dust inside the machine terminal cover or case; remove carefully with compressed air
- Signs of corrosion on terminals, on the case or inside the machine terminal

For information about the maintenance of machine terminals, refer to section “Service” on page 82.



Machine terminals are measuring instruments and should be handled with care and protected against moisture and mechanical stress, especially during transport.

**3.3.****Configuration**

The REM 54\_ machine terminals are adapted to specific applications by using the Relay Configuration Tool included in the CAP 505 tools. This tool is used for configuring the basic terminal, protection and logic function blocks, control and measurement functions, timers and other functional elements included in the logic functions category (refer to section “Machine terminal configuration” on page 26).

The MIMIC picture, alarm texts and LED indicators are configured with the Relay Mimic Editor (refer to section “MIMIC configuration” on page 27).

The configuration of LON network is described in section “LON network configuration” on page 29. If the application includes no horizontal communication, network variables are not needed and the section about LON network configuration is thus not relevant.

The configuration procedure starts by configuring the functions of protection, control, condition monitoring, measurement and logics.

For more detailed information about the configuration, refer to the Configuration Guideline and the tool-specific manuals (refer to section “References” on page 89).

## 4. Technical Description

### 4.1. Functional description

#### 4.1.1. Functions of the machine terminal

The functions of the REM 54\_ machine terminal are categorized as:

- protection functions
- measurement functions
- control functions
- condition monitoring functions
- communication functions
- general functions
- standard functions

The functions are further divided to two subsets that correspond to different functionality levels (refer to section “Ordering Information” on page 83).

#### 4.1.1.1. Protection functions

Protection is one of the most important functions of the REM 54\_ machine terminal. The protection function blocks (e.g. NOC3Low) are independent of each other and have their own setting groups, data recording, etc. The non-directional overcurrent protection, for example, includes the three stages NOC3Low, NOC3High and NOC3Inst, each with independent protection functions.

Either Rogowski coils or conventional current transformers can be used for protection functions based on current measurement (overcurrent). Correspondingly, voltage dividers or voltage transformers are used for protection functions based on voltage measurement (overvoltage).

The protection function blocks are documented on the CD-ROM “Technical Descriptions of Functions” (1MRS750889-MCD).

**Table 4.1.1.1.-1 Protection functions available for the REM 54\_**

Function	Description
DEF2Low	Directional earth-fault protection, low-set stage
DEF2High	Directional earth-fault protection, high-set stage
DEF2Inst	Directional earth-fault protection, instantaneous stage
Diff3 <sup>1)</sup>	High-impedance or flux-balance based differential protection for generators and motors
Diff6G	Stabilized three-phase differential protection for generators
Freq1St1	Underfrequency or overfrequency protection, stage 1
Freq1St2	Underfrequency or overfrequency protection, stage 2
Freq1St3	Underfrequency or overfrequency protection, stage 3
Freq1St4	Underfrequency or overfrequency protection, stage 4
Freq1St5	Underfrequency or overfrequency protection, stage 5
FuseFail <sup>1)</sup>	Fuse failure supervision
Inrush3	Three-phase transformer inrush and motor start-up current detector
MotStart	Three-phase start-up supervision for motors

**Table 4.1.1.1.-1 Protection functions available for the REM 54\_**

Function	Description
NEF1Low	Non-directional earth-fault protection, low-set stage
NEF1High	Non-directional earth-fault protection, high-set stage
NEF1Inst	Non-directional earth-fault protection, instantaneous stage
NOC3Low	Three-phase non-directional overcurrent protection, low-set stage
NOC3High	Three-phase non-directional overcurrent protection, high-set stage
NOC3Inst	Three-phase non-directional overcurrent protection, instantaneous stage
NPS3Low	Negative-phase-sequence (NPS) protection, low-set stage
NPS3High	Negative-phase-sequence (NPS) protection, high-set stage
NUC3St1	Three-phase non-directional undercurrent protection, stage 1
NUC3St2	Three-phase non-directional undercurrent protection, stage 2
OE1Low <sup>1)</sup>	Overexcitation protection, low-set stage
OE1High <sup>1)</sup>	Overexcitation protection, high-set stage
OPOW6St1	Three-phase overpower protection, stage 1
OPOW6St2	Three-phase overpower protection, stage 2
OPOW6St3	Three-phase overpower protection, stage 3
OV3Low	Three-phase overvoltage protection, low-set stage
OV3High	Three-phase overvoltage protection, high-set stage
PREV3 <sup>1)</sup>	Phase reversal protection
PSV3St1 <sup>1)</sup>	Phase-sequence voltage protection, stage 1
PSV3St2 <sup>1)</sup>	Phase-sequence voltage protection, stage 2
REF1A	High-impedance based restricted earth-fault protection
ROV1Low	Residual overvoltage protection, low-set stage
ROV1High	Residual overvoltage protection, high-set stage
ROV1Inst	Residual overvoltage protection, instantaneous stage
TOL3Dev	Three-phase thermal overload protection for devices
UE6Low	Three-phase underexcitation protection, low-set stage
UE6High	Three-phase underexcitation protection, high-set stage
UI6Low <sup>1)</sup>	Three-phase underimpedance protection, low-set stage
UI6High <sup>1)</sup>	Three-phase underimpedance protection, high-set stage
UPOW6St1	Three-phase underpower or reverse-power protection, stage 1
UPOW6St2	Three-phase underpower or reverse-power protection, stage 2
UPOW6St3	Three-phase underpower or reverse-power protection, stage 3
UV3Low	Three-phase undervoltage protection, low-set stage
UV3High	Three-phase undervoltage protection, high-set stage
VOC6Low	Voltage-dependent overcurrent protection, low-set stage
VOC6High	Voltage-dependent overcurrent protection, high-set stage

<sup>1)</sup> These functions are only supported in the machine terminal revisions of the Release 2.0 or later, refer to section "Revision identification" on page 85.

#### 4.1.1.2.

#### Measurement functions

The measurement function blocks are documented on the CD-ROM "Technical Descriptions of Functions" (1MRS750889-MCD).

**Table 4.1.1.2.-1 Measurement functions available for REM 54\_**

Function	Description
MEAI1 <sup>1)</sup>	General measurement 1 / analogue input on RTD1 card

**Table 4.1.1.2.-1 Measurement functions available for REM 54\_**

Function	Description
MEAI2 <sup>1)</sup>	General measurement 2 / analogue input on RTD1 card
MEAI3 <sup>1)</sup>	General measurement 3 / analogue input on RTD1 card
MEAI4 <sup>1)</sup>	General measurement 4 / analogue input on RTD1 card
MEAI5 <sup>1)</sup>	General measurement 5 / analogue input on RTD1 card
MEAI6 <sup>1)</sup>	General measurement 6 / analogue input on RTD1 card
MEAI7 <sup>1)</sup>	General measurement 7 / analogue input on RTD1 card
MEAI8 <sup>1)</sup>	General measurement 8 / analogue input on RTD1 card
MEAO1 <sup>1)</sup>	Analogue output 1 on RTD1 card
MEAO2 <sup>1)</sup>	Analogue output 2 on RTD1 card
MEAO3 <sup>1)</sup>	Analogue output 3 on RTD1 card
MEAO4 <sup>1)</sup>	Analogue output 4 on RTD1 card
MECU1A	Neutral current measurement, stage A
MECU1B	Neutral current measurement, stage B
MECU3A	Three-phase current measurement, stage A
MEDREC16	Transient disturbance recorder
MEFR1	System frequency measurement
MEPE7	Three-phase power and energy measurement
MEVO1A	Residual voltage measurement, stage A
MEVO3A	Three-phase voltage measurement, stage A

<sup>1)</sup> These functions are only supported in the machine terminal revisions of the Release 2.0 or later, refer to section "Revision identification" on page 85.

### 4.1.1.3.

#### Control functions

The control functions are used to indicate the status of switching devices, i.e. circuit breakers and disconnectors, and to execute open and close commands for controllable switching devices of the switchgear. Furthermore, control functions provide on/off switching objects for control logic purposes and miscellaneous objects for data monitoring, etc.

The control functions configured with the Relay Configuration Tool must be associated with object status indicators that are part of the MIMIC configuration picture displayed on the MMI. The object status indicators are used to indicate the status of switching devices via the MIMIC picture and to control them locally. For more information about the MIMIC configuration, refer to section "MIMIC configuration" on page 27.

The control function blocks are documented on the CD-ROM "Technical Descriptions of Functions" (1MRS750889-MCD).

**Table 4.1.1.3.-1 Control functions available for REM 54\_**

Function	Description
COCB1	Circuit breaker 1 control with indication
COCB2	Circuit breaker 2 control with indication
COCBDIR	Direct open for CBs via MMI
CO3DC1	Three-state disconnector (1) with indication
CO3DC2	Three-state disconnector (2) with indication
CODC1	Disconnector 1 control with indication

**Table 4.1.1.3.-1 Control functions available for REM 54\_**

Function	Description
CODC2	Disconnecter 2 control with indication
CODC3	Disconnecter 3 control with indication
CODC4	Disconnecter 4 control with indication
CODC5	Disconnecter 5 control with indication
COIND1	Switching device 1 indication
COIND2	Switching device 2 indication
COIND3	Switching device 3 indication
COIND4	Switching device 4 indication
COIND5	Switching device 5 indication
COIND6	Switching device 6 indication
COIND7	Switching device 7 indication
COIND8	Switching device 8 indication
COLOCAT	Logic-controlled control position selector
COSW1	On/off switch 1
COSW2	On/off switch 2
COSW3	On/off switch 3
COSW4	On/off switch 4
MMIALAR1	Alarm channel 1, LED indication
MMIALAR2	Alarm channel 2, LED indication
MMIALAR3	Alarm channel 3, LED indication
MMIALAR4	Alarm channel 4, LED indication
MMIALAR5	Alarm channel 5, LED indication
MMIALAR6	Alarm channel 6, LED indication
MMIALAR7	Alarm channel 7, LED indication
MMIALAR8	Alarm channel 8, LED indication
MMIDATA1	MIMIC data monitoring point 1
MMIDATA2	MIMIC data monitoring point 2
MMIDATA3	MIMIC data monitoring point 3
MMIDATA4	MIMIC data monitoring point 4
MMIDATA5	MIMIC data monitoring point 5

**4.1.1.4.****Condition monitoring functions**

The condition monitoring function blocks are documented on the CD-ROM “Technical descriptions of Functions” (1MRS750889-MCD).

**Table 4.1.1.4.-1 Condition monitoring functions available for REM 54\_**

Function	Description
CMBWEAR1	Circuit-breaker electric wear 1
CMBWEAR2	Circuit-breaker electric wear 2
CMCU3	Supervision function of the energizing current input circuit
CMGAS1	Gas density monitoring 1
CMGAS3 <sup>1)</sup>	Three-pole gas density monitoring
CMSCHED	Scheduled maintenance
CMSPRC1	Spring charging control 1
CMTCS1	Trip circuit supervision 1
CMTCS2	Trip circuit supervision 2
CMTIME1	Operate time counter 1 for the operate time used (e.g. motors)

**Table 4.1.1.4.-1 Condition monitoring functions available for REM 54\_**

Function	Description
CMTIME2	Operate time counter 2 for the operate time used (e.g. motors)
CMTRAV1	Breaker travel time 1
CMVO3	Supervision function of the energizing voltage input circuit

<sup>1)</sup> This function is only supported in the machine terminal revisions of the Release 2.0 or later, refer to section "Revision identification" on page 85.

**4.1.1.5.****Communication**

The REM 54\_ machine terminal provides the SPA and LON serial communication protocols.

In a customer-specific machine terminal configuration, special events can be generated via an EVENT230 event function. EVENT230 is documented on the CD-ROM "Technical descriptions of Functions" (1MRS750889-MCD).

For more information about communication in the REM 54\_ machine terminal, refer to section "Serial communication" on page 62.

**4.1.1.6.****General functions**

The general function blocks are documented on the CD-ROM "Technical Descriptions of Functions" (1MRS750889-MCD).

**Table 4.1.1.6.-1 General functions available for REM 54\_**

Function	Description
INDRESET	Resetting of operation indicators, latched output signals, registers and waveforms i.e. the disturbance recorder
MMIWAKE	Activation of MMI backlight
SWGRP1	Switchgroup SWGRP1
SWGRP2	Switchgroup SWGRP2
SWGRP3	Switchgroup SWGRP3
.....	
SWGRP20	Switchgroup SWGRP20

**4.1.1.7.****Standard functions**

Standard functions are used for logics such as interlocking, alarming and control sequencing. The use of logic functions is not limited and the functions can be interconnected with protection, control, measurement, condition monitoring and other standard functions. In addition, the digital inputs and outputs as well as LON inputs and outputs can be connected to standard functions by using the Relay Configuration Tool.

The standard function blocks are documented on the CD-ROM "Technical descriptions of Functions" (1MRS750889-MCD).

**Table 4.1.1.7.-1 Standard functions available for REM 54\_**

Function	Description
ABS	Absolute value
ACOS	Principal arc cosine
ADD	Extensible adder

**Table 4.1.1.7.-1 Standard functions available for REM 54\_**

Function	Description
AND	Extensible AND connection
ASIN	Principal arc sine
ATAN	Principal arc tangent
BITGET	Get one bit
BITSET	Set one bit
BOOL_TO_*	Type conversion from BOOL to WORD / USINT / UINT / UDINT / SINT / REAL / INT / DWORD / DINT / BYTE
BOOL2INT	Type conversion from BOOL inputs to INT output
BYTE_TO_*	Type conversion from BYTE to WORD / DWORD
COMH	Hysteresis comparator
COS	Cosine in radians
CTD	Down-counter
CTUD	Up-down counter
CTU	Up-counter
DATE_TO_UDINT	Type conversion from DATE to UDINT
DINT_TO_*	Type conversion from DINT to SINT / REAL / INT
DIV	Divider
DWORD_TO_*	Type conversion from DWORD to WORD / BYTE
EQ	Extensible comparison to equal
EXP	Natural exponential
EXPT	Exponentiation
F_TRIG	Falling edge detector
GE	Extensible comparison to greater or equal
GT	Extensible comparison to greater
INT_TO_*	Type conversion from INT to REAL / DINT
INT2BOOL	Type conversion from INT input to BOOL outputs
LE	Extensible comparison to less or equal
LIMIT	Limitation
LN	Natural logarithm
LOG	Logarithm base 10
LT	Extensible comparison to less
MAX	Extensible maximum
MIN	Extensible minimum
MOD	Modulo
MOVE	Move
MUL	Extensible multiplier
MUX	Extensible multiplexer
NE	Comparison to greater or less
NOT	Complement
OR	Extensible OR connection
R_TRIG	Rising edge detector
REAL_TO_*	Type conversion from REAL to USINT / UINT / UDINT / SINT / INT / DINT
ROL	Rotate to left
ROR	Rotate to right
RS	Reset dominant bistable function block
RS_D	Reset dominant bistable function block with data input
SEL	Binary selection

**Table 4.1.1.7.-1 Standard functions available for REM 54\_**

Function	Description
SHL	Bit-shift to left
SHR	Bit-shift to right
SIN	Sine in radians
SINT_TO_*	Type conversion from SINT to REAL / INT / DINT
SUB	Subtractor
SQRT	Square root
SR	Set dominant bistable function block
XOR	Extensible exclusive OR connection
TAN	Tangent in radians
TIME_TO_*	Type conversion from TIME to UDINT / TOD / REAL
TOD_TO_*	Type conversion from TOD to UDINT / TIME / REAL
TOF	Off-delay timer
TON	On-delay timer
TP	Pulse
TRUNC_*	Truncation toward zero
UDINT_TO_*	Type conversion from UDINT to USINT / UINT / REAL
UINT_TO_*	Type conversion from UINT to USINT / UDINT / REAL / BOOL
USINT_TO_*	Type conversion from USINT to UINT / UDINT / REAL
WORD_TO_*	Type conversion from WORD to DWORD / BYTE

## 4.1.2.

### Configuration

#### 4.1.2.1.

#### Machine terminal configuration

The Relay Configuration Tool is based on the IEC 61131-3 standard. The standard defines the programming language used for configuration. The programmable system of REM 54\_ machine terminals allows the output contacts to be operated in accordance with the state of the logic inputs and the outputs of the protection, control, measurement and condition monitoring functions. The PLC functions (e.g. interlocking and alarm logic) are programmed with Boolean functions, timers, counters, comparators and flip-flops. The program is written in a function block diagram language by using the configuration software.

After the configuration has been built and successfully compiled, and the MIMIC configuration has been designed, the project can be downloaded to the relay with the Relay Download Tool. The project can also be uploaded from the machine terminal with the same tool<sup>1</sup>.

For more information about the configuration and the Relay Configuration Tool refer to the Configuration Guideline and the tool manuals (refer to section “References” on page 89).

---

1. This function is only supported in the machine terminal revisions of the Release 2.0 or later, refer to section “Revision identification” on page 85.



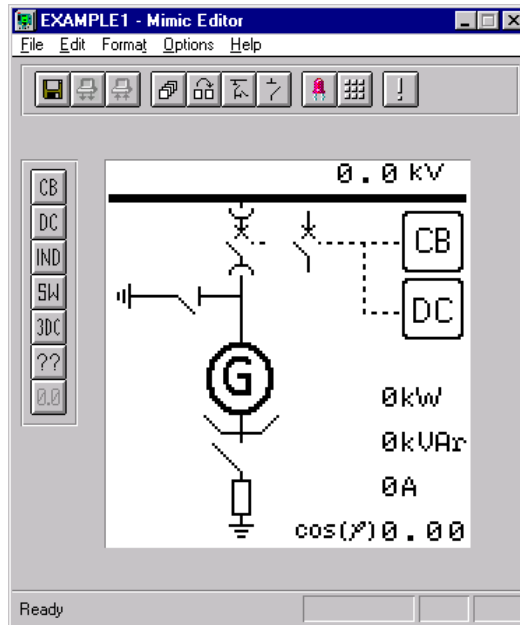

Mimic Editor

Fig. 4.1.2.2.-1 MIMIC configuration with the Relay Mimic Editor

The contents of the alarm view are configured with the Relay Mimic Editor by defining the ON and OFF state texts (max 16 characters), see Figure 4.1.2.2.-2 below. For defining the corresponding LED colours refer to section “Alarm LED indicators” on page 67.

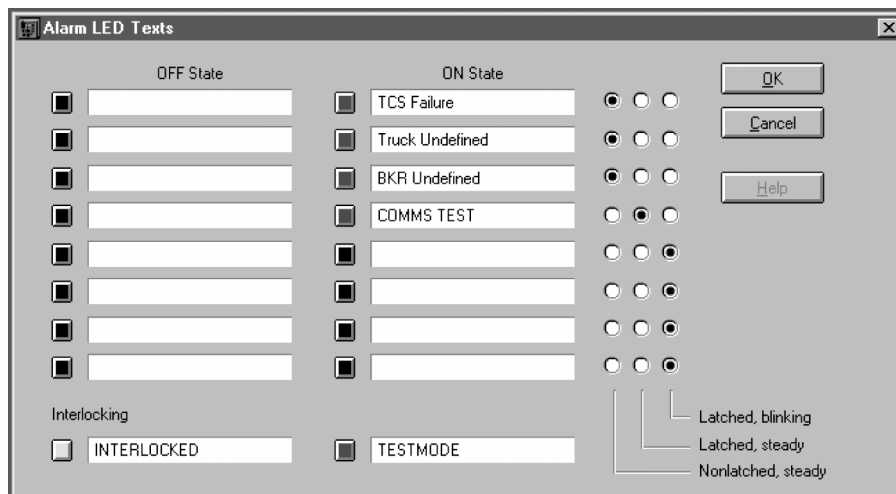

Fig. 4.1.2.2.-2 Alarm channel configuration

Interlocking LED texts can also be defined in the view illustrated above, but the interlocking LED colours cannot be changed. For the operation of the interlocking LED, refer to section “Interlocking” on page 69.

For more information about the use of the editor, refer to the Relay Mimic Editor manual (refer to section “References” on page 89).

### 4.1.2.3. LON network configuration

The LON Network Tool is used for binding network variables between RED 500 terminals. Typically, LON is used for transferring status data between the terminals for interlocking sequences running in the units, see Figure 4.1.2.3.-1 below and Figure 4.1.13.6.-1 on page 64.

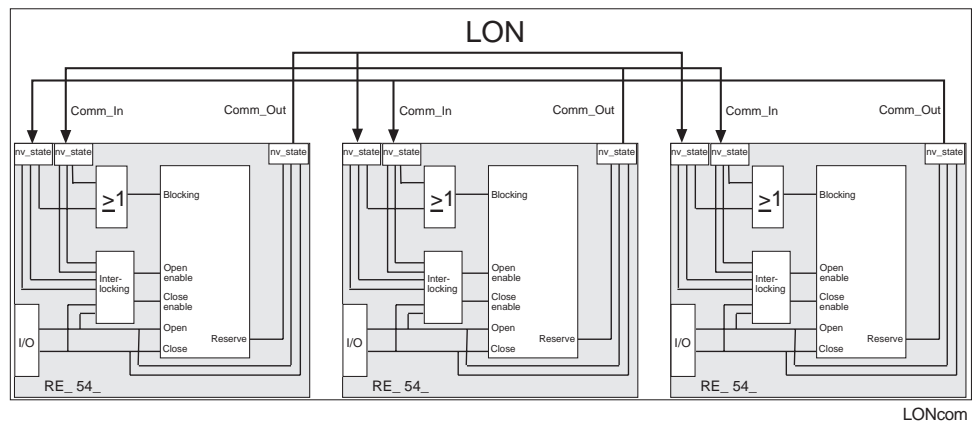

Fig. 4.1.2.3.-1 Communication between RED 500 terminals in station interlocking

For more information about the use of the tool, refer to the LNT 505 Operator's Manual (refer to section "References" on page 89).

### 4.1.2.4. Rated frequency

The rated frequency of the machine terminal is set in association with configuration via a dialogue box in the Relay Configuration Tool. The set rated frequency cannot be changed afterwards via the MMI or serial communication, but it can be read via the global control parameter "Rated frequency" of the machine terminal.

### 4.1.3. Parameters and events

The function blocks and I/O cards include a large number of parameters and events. In addition, general parameters and events are provided, e.g. parameters for control and communication as well as events for testing and self-supervision.

The function block specific parameters are listed in each function block description. Moreover, all parameters and events for REM 54\_ are listed in the parameter and event lists. The function block descriptions as well as the parameter and event lists are included on the CD-ROM "Technical Descriptions of Functions" (refer to section "References" on page 89).

### 4.1.4. Parameterization

To ensure that a protection function block protects the machine in the desired manner, the default values of parameters are to be checked and properly set before taking the function block into use.

The parameters can be set either locally over the MMI or externally via the serial communication.

#### 4.1.4.1. Local parameterization

When the parameters are set locally via the MMI, the setting parameters can be chosen from the hierarchical menu structure. The desired language for parameter description can also be selected. Detailed information about setting and navigation is found in the RE\_ 54\_ Operator's Manual (1MRS750500-MUM).

#### 4.1.4.2. External parameterization

The Relay Setting Tool is used for parameterizing and setting the REM 54\_ machine terminals externally. The parameters can be set off-line on a PC and downloaded to the machine terminal over a communication port. The menu structure of the setting tool, including views relating to parameterization and settings, is the same as the menu structure of the machine terminal. The use of the tool is instructed in the RED Relay Tool Operator's Manual (refer to section "References" on page 89).

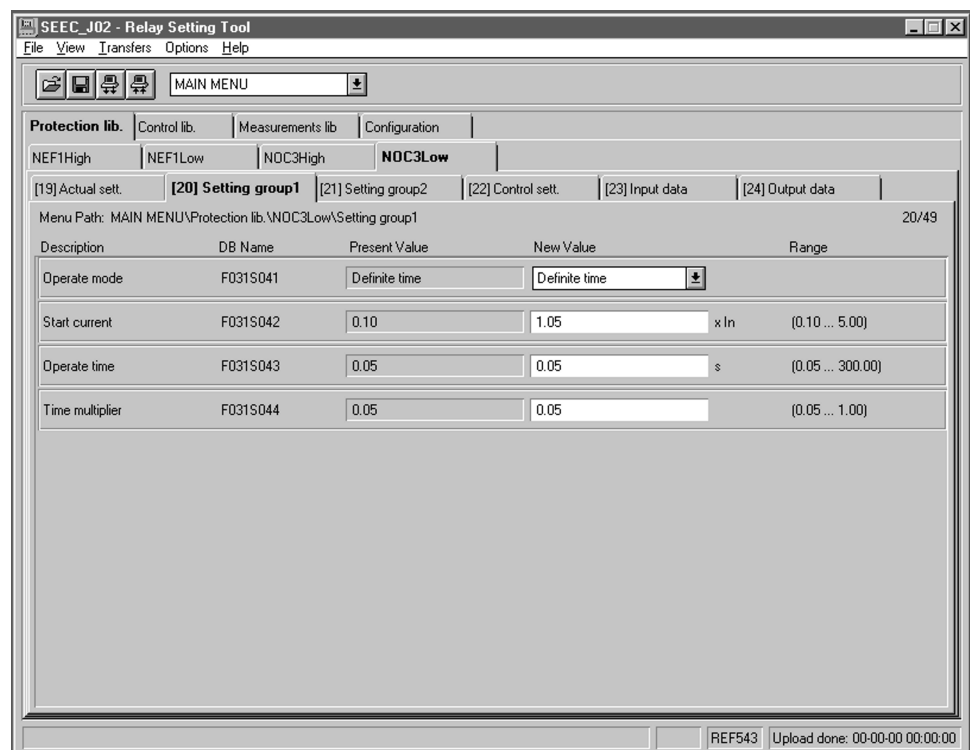

Fig. 4.1.4.2.-1 Main dialogue box of the Relay Setting Tool

#### 4.1.4.3. Storing of parameters and recorded data

When parameter values are changed, the new values take effect immediately. However, the new parameter values as well as the recorded data are saved in a non-volatile memory only after they have been stored via the parameter "Store" in the menu Configuration/General (refer also to the Operator's Manual 1MRS 750500-MUM) or via the relay tools.

Provided the storing was completed successfully, the information stored in the non-volatile memory is preserved in the memory also in case of a power interruption. During the storing procedure, it is not possible to reset the machine terminal via the parameter "Software reset" or to load a new project.



When the values for the measuring devices (refer to section “Technical data of the measuring devices” on page 36) are changed via the MMI or the Relay Setting Tool, the new values take effect only after they have been stored via the parameter “Store” and the machine terminal has been reset via the parameter “Software reset” in the menu Configuration/General.

#### 4.1.5.

### Auxiliary voltage

For its operation the REM 54\_ terminal, including the external display module, requires a secured auxiliary voltage supply. The machine terminal’s internal power supply module forms the voltages required by the machine terminal electronics. The power supply module is a galvanically isolated (flyback-type) DC/DC converter. A green protection LED indicator on the front panel is lit when the power supply module is in operation.



The main unit and the external display module must each be provided with separate power supply from a common source.

The machine terminal is provided with a 48-hour capacitor back-up protection<sup>1</sup> that enables the internal clock to keep time in case of an auxiliary power failure.

#### 4.1.5.1.

### Power supply versions

The power supply module PS1/\_ is available for the REM 54\_. The module is available in two versions with identical output voltages but different input voltages.

When REM 54\_ is delivered with a fixed display module, the input voltage range of the power supply module is marked on the front panel of the machine terminal. When the machine terminal is provided with an external display module, the input voltage of the display module is marked on the front panel of the module and the input voltage of the main unit is marked on the side of the unit.

The external display module is only available together with a main unit equipped with the PS\_/240 power supply module.

The power supply version is specified by the first letter in the order number of REM 54\_ (refer to section “Ordering Information” on page 83). The voltage range of the digital inputs is tied to the selected power supply. If a power supply version with the higher rated input voltage is selected, the machine terminals will be delivered with digital inputs that also have the higher rated input voltage.

The auxiliary voltages of power supply modules and the corresponding rated input voltages of digital inputs are:

Power supply module	Rated input voltage of power supply	Rated input voltage of digital inputs
PS1/240	110/120/220/240 V ac or 110/125/220 V dc	110/125/220 V dc
PS1/48	24/48/60 V dc	24/48/60/110/125/220 V dc
External display module	110/120/220/240 V ac or 110/125/220 V dc	-

For further technical data of the power supply, refer to Table 4.2.1.-2 on page 70.

1. This function is only supported in the machine terminal revisions of the Release 2.0 or later, refer to section “Revision identification” on page 85.

### 4.1.5.2. Low auxiliary voltage indication

The REM 54\_ machine terminal is provided with a low auxiliary voltage indication feature. The power supply module issues an internal alarm signal when a drop in the power supply voltage is detected (ACFail, active low). The alarm signal is activated if the power supply voltage falls about 10% below the lowest rated dc input voltage of the power supply module, see the table below:

Rated input voltage	Low indication level
PS1/240	
• Rated input voltage 110/125/ 220 V dc	99 V dc
• Rated input voltage 110/120/220/ 240 V ac	88 V ac
PS1/48	
• Rated input voltage 24/48/60 V dc	21.6 V dc

The indication of a low auxiliary voltage (ACFail) is available in the machine terminal configuration environment and can be connected to any signal output of the REM 54\_. The auxiliary voltage indication in the machine terminal configuration is as follows:

REM 543: PS1\_4\_ACFail

REM 545: PS1\_4\_ACFail

### 4.1.5.3. Overtemperature indication

The REM 54\_ machine terminal includes an internal temperature supervision function. The power supply module issues an internal alarm signal when overtemperature has been detected inside the terminal enclosure. The alarm signal will be activated once the temperature inside the terminal enclosure increases to +78°C (+75...+83° C). Overtemperature indication is available in the machine terminal configuration and can be connected to any signal output of the terminal. The overtemperature indication input in the machine terminal configuration is as follows:

REM 543: PS1\_4\_TempAlarm

REM 545: PS1\_4\_TempAlarm

### 4.1.6. Analogue channels

The machine terminal measures the analogue signals needed for protection, measuring, etc. via sensors or galvanically separated matching transformers. The machine terminals can be provided with the following matching transformers:

- 5 current and 4 voltage transformers:  
CT1, CT2, CT3, CT4, CT5, VT1, VT2, VT3, VT4
- 6 current and 3 voltage transformers:  
CT1, CT2, CT3, CT4, CT5, CT6, VT1, VT2, VT3
- 7 current and 2 voltage transformers:  
CT1, CT2, CT3, CT4, CT5, CT6, CT7, VT1, VT2
- 8 current and 1 voltage transformers:  
CT1, CT2, CT3, CT4, CT5, CT6, CT7, CT8, VT1

In addition to conventional matching transformers, current sensors and voltage dividers developed by ABB can be used in REM 54\_ machine terminals. The machine terminal has 9 sensor inputs<sup>1</sup>. A current sensor (Rogowski coil) or a voltage divider can be connected to each sensor input. The machine terminal allows the user to configure each sensor input for the type of sensor to be used. Furthermore, the machine terminal is provided with general measurement via sensor inputs. This allows e.g. temperature monitoring, provided a temperature sensor with a voltage transducer output is available.

The third letter in the four-letter extension of the order number specifies whether the machine terminal is to be equipped with conventional matching transformers or with matching transformers and sensor inputs. (Refer to section “Ordering Information” on page 83).

- REM543B\_212AA\_A /CA\_A /AA\_B
- REM543A\_213AA\_A /CA\_A /AA\_B
- REM543B\_214AA\_A /CA\_A /AA\_B
- REM543A\_215AA\_A /CA\_A /AA\_B
- REM543B\_216AA\_A /CA\_A /AA\_B
- REM543A\_217AA\_A /CA\_A /AA\_B
- REM543B\_218AA\_A /CA\_A /AA\_B
- REM543A\_219AA\_A /CA\_A /AA\_B
- REM545A\_222AA\_A /CA\_A /AA\_B
- REM545A\_223AA\_A /CA\_A /AA\_B
- REM545A\_224AA\_A /CA\_A /AA\_B
- REM545A\_225AA\_A /CA\_A /AA\_B
- REM545A\_226AA\_A /CA\_A /AA\_B
- REM545A\_227AA\_A /CA\_A /AA\_B
- REM545A\_228AA\_A /CA\_A /AA\_B
- REM545A\_229AA\_A /CA\_A /AA\_B

The matching transformers and sensor inputs of the machine terminal are designed so as to allow either sensors or matching transformers to be used on the measuring channels 2...5 and 7...10. Should a matching transformer be used on a channel, no sensor is allowed to be used on the same channel or vice versa. On channel 1 only sensors can be used and on channel 6 only a matching transformer.

---

1. Machine terminal revisions of releases prior to the Release 2.0 are provided with 8 sensor channels.

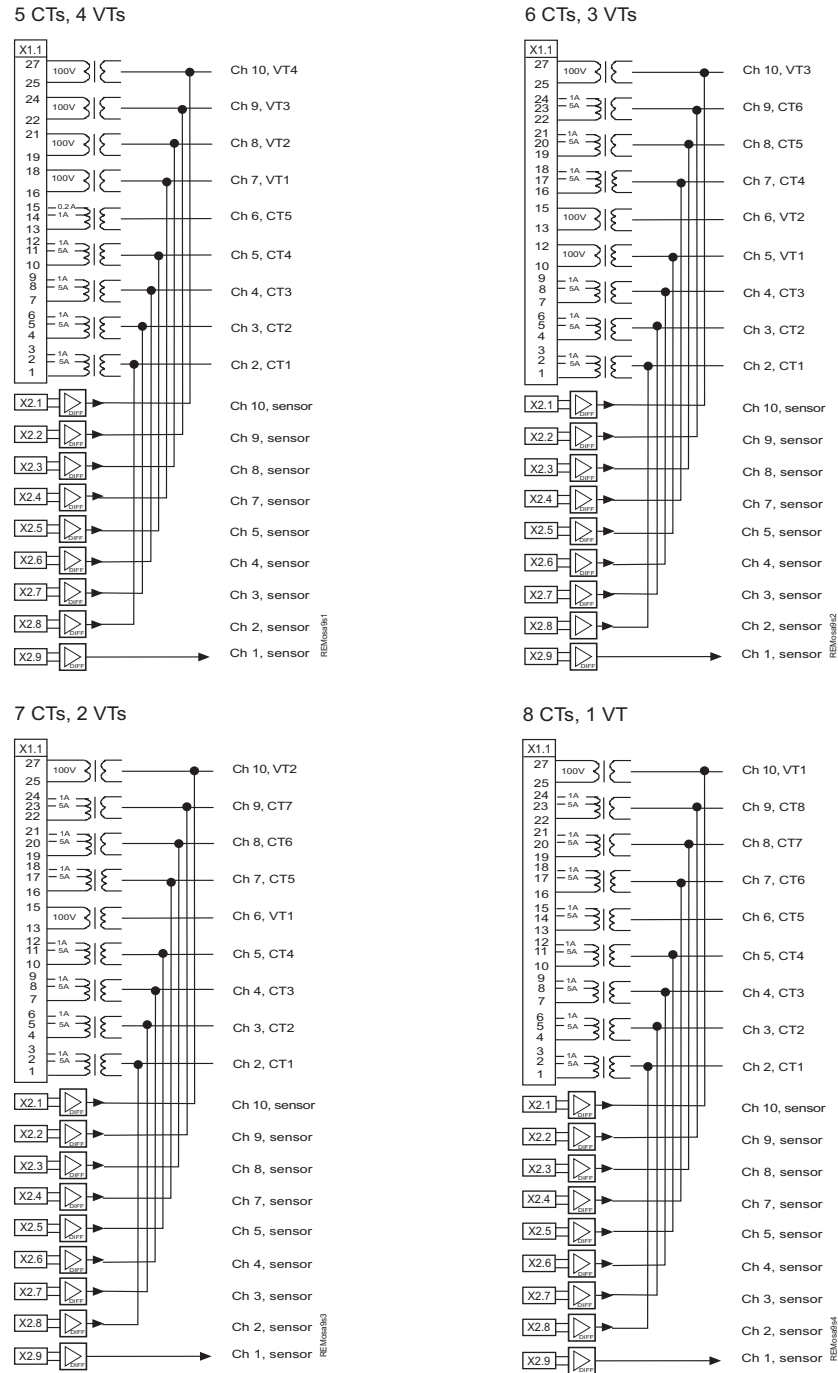

Fig. 4.1.6.-1 Analogue channel configurations of REM 54\_ products

Depending on whether sensors are included or not, REM 54\_ machine terminals have 9 (without sensors) or 10 (with sensors) physical analogue channels (see table below). The number of channels used depends on the machine terminal configuration and the kind of matching transformers or sensor inputs used.

Furthermore, the machine terminal includes virtual analogue channels (refer to section “Calculated analogue channels” on page 39) for calculating the neutral current and residual voltage from phase currents and voltages.

## Technical Reference Manual

Each analogue channel is separately configured with the Relay Configuration Tool. Both the measuring unit for each analogue channel and the type of signal to be measured are to be configured.

**Table 4.1.6.-1 Physical analogue channels of the machine terminals**

Ch No.	Measuring units					
	Current Transformer (CT)	Voltage Transformer (VT)	Rogovski coil/-sensor (RS)	Voltage divider (VD)	General measurement	Signal type (selectable alternatives)
1			RS type 1...10	VD type 1...10	Gen. meas. 1...3	Not in use, $I_{L1}, I_{L2}, I_{L3},$ $I_{L1b}, I_{L2b}, I_{L3b},$ $U_1, U_2, U_3,$ $U_{1b}, U_{2b}, U_{3b}, U_{1c},$ GE1, GE2, GE3
2	Current Transformer CT1 ( $I_n = 1 \text{ A/5 A}$ )		RS type 1...10	VD type 1...10	Gen. meas. 1...3	Not in use, $I_{L1}, I_{L2}, I_{L3},$ $I_{L1b}, I_{L2b}, I_{L3b},$ $I_0, I_{0b},$ $U_1, U_2, U_3,$ $U_{1b}, U_{2b}, U_{3b}, U_{1c},$ GE1, GE2, GE3
3	Current Transformer CT2 ( $I_n = 1 \text{ A/5 A}$ )					
4	Current Transformer CT3 ( $I_n = 1 \text{ A/5 A}$ )					
5	Current Transformer CT4 ( $I_n = 1 \text{ A/5 A}$ )	Voltage Transformer VT1 ( $U_n = 100\text{V}/110\text{V}/115\text{V}/120\text{V}$ )	RS type 1...10	VD type 1...10	Gen. meas. 1...3	Not in use, $I_{L1}, I_{L2}, I_{L3},$ $I_{L1b}, I_{L2b}, I_{L3b},$ $I_0, I_{0b},$ $U_{12}, U_{23}, U_{31},$ $U_{12b}, U_{23b}, U_{31b}, U_{12c},$ $U_1, U_2, U_3,$ $U_{1b}, U_{2b}, U_{3b},$ $U_{1c}, U_0, U_{0b},$ GE1, GE2, GE3
6	Current Transformer CT5 ( $I_n = 0.2 \text{ A/1 A}$ )	Voltage Transformer VT1 or VT2 ( $U_n = 100\text{V}/110\text{V}/115\text{V}/120\text{V}$ )				Not in use, $I_{L1}, I_{L2}, I_{L3},$ $I_{L1b}, I_{L2b}, I_{L3b},$ $I_0, I_{0b},$ $U_{12}, U_{23}, U_{31},$ $U_{12b}, U_{23b}, U_{31b}, U_{12c},$ $U_1, U_2, U_3,$ $U_{1b}, U_{2b}, U_{3b}, U_{1c},$ $U_0, U_{0b}$
7	Current Transformer CT4, CT5 or CT6 ( $I_n = 1 \text{ A/5 A}$ )	Voltage Transformer VT1 ( $U_n = 100\text{V}/110\text{V}/115\text{V}/120\text{V}$ )	RS type 1...10	VD type 1...10	Gen. meas. 1...3	Not in use, $I_{L1}, I_{L2}, I_{L3},$ $I_{L1b}, I_{L2b}, I_{L3b},$ $I_0, I_{0b},$ $U_{12}, U_{23}, U_{31},$ $U_{12b}, U_{23b}, U_{31b}, U_{12c},$ $U_1, U_2, U_3,$ $U_{1b}, U_{2b}, U_{3b}, U_{1c},$ $U_0, U_{0b},$ GE1, GE2, GE3
8	Current Transformer CT5, CT6 or CT7 ( $I_n = 1 \text{ A/5 A}$ )	Voltage Transformer VT2 ( $U_n = 100\text{V}/110\text{V}/115\text{V}/120\text{V}$ )				
9	Current Transformer CT6, CT7 or CT8 ( $I_n = 1 \text{ A/5 A}$ )	Voltage Transformer VT3 ( $U_n = 100\text{V}/110\text{V}/115\text{V}/120\text{V}$ )				
10		Voltage Transformer VT4 ( $U_n = 100\text{V}/110\text{V}/115\text{V}/120\text{V}$ )	RS type 1...10	VD type 1...10	Gen. meas. 1...3	Not in use, $I_{L1}, I_{L2}, I_{L3},$ $I_{L1b}, I_{L2b}, I_{L3b},$ $U_{12}, U_{23}, U_{31},$ $U_{12b}, U_{23b}, U_{31b}, U_{12c},$ $U_1, U_2, U_3,$ $U_{1b}, U_{2b}, U_{3b}, U_{1c},$ $U_0, U_{0b},$ GE1, GE2, GE3

The letters b and c after the signal type are used to distinguish between signals of the same type.

**4.1.6.1.****Setting the rated values for the protected unit**

A separate scaling factor can be set for each analogue channel. The factors enable differences between the ratings of the protected unit (generator, transformer, motor etc.) and those of the measuring device (CTs, VTs etc.) The setting value 1.00 means that the rated value of the protected unit is exactly the same as that of the measuring device.

When scaling factors are used, it should be noted that they affect the operation accuracy of the terminal. The accuracies stated in the description of each function block (CD-ROM “Technical Descriptions of Functions”) only apply with the default values of the scaling factors. For example, a high factor affects the operation of sensitive protection functions such as the directional earth-fault protection.

The scaling factor is calculated channel by channel as follows:

Scaling factor =  $I_{nmd} / I_{np}$ , where

$I_{nmd}$	Rated primary current of the measuring device (A)
$I_{np}$	Rated primary current of the protected unit connected to the channel

Example:

Rated primary current of current trafo = 500 A:	$I_{nmd} = 500 \text{ A}$
Rated current of the protected unit = 250 A:	$I_{np} = 250 \text{ A}$
Scaling factor for current channels:	$500 \text{ A} / 250 \text{ A} = 2.00$



The scaling factor is not used for general measurement signals connected to the analogue channel.

The scaling factors for the analogue channels can be set via the MMI of the machine terminal or with the Relay Setting Tool. The MMI path for the scaling factors is: Main Menu/ Configuration/ Protected Unit/ Ch 1: scaling, Ch 2: scaling...

**4.1.6.2.****Technical data of the measuring devices**

When the machine terminal is configured, the technical data of the measuring devices is set in separate dialogue boxes in the Relay Configuration Tool. The set values will affect the measurements carried out by the machine terminal.

For storing the values listed below, refer to section “Storing of parameters and recorded data” on page 30.

**Values to be set for a current transformer are:**

- rated primary current (0...6000 A) of the primary current transformer
- rated secondary current (5 A, 2 A, 1 A, 0.2 A) of the primary current transformer
- rated current (5 A, 1 A, 0.2 A) of the current measuring input (= rated current of the matching transformer of the machine terminal)
- amplitude correction factor (0.9000...1.1000) of the primary current transformer at rated current
- correction parameter for the phase displacement error of the primary current transformer at rated current ( $-5.00^\circ$ ... $0.00^\circ$ )
- amplitude correction factor of the primary current transformer at a signal level of 1% of the rated current (0.9000...1.1000)
- correction parameter for the phase displacement error of the primary current transformer at a signal level of 1% of the rated current ( $-10.00^\circ$ ... $0.00^\circ$ )

**Values to be set for a voltage transformer are:**

- rated voltage of voltage input (same as the secondary rated voltage of the primary voltage transformer connected to the voltage input, 100 V, 110 V, 115 V, 120 V)
- rated voltage of primary voltage transformer (0...440 kV)
- amplitude correction factor of the primary voltage transformer voltage at rated voltage (0.9000...1.1000)
- correction parameter for the primary transformer phase displacement error at rated voltage ( $-2.00^\circ$ ...  $2.00^\circ$ )

**Values to be set for a current sensor (Rogowski coil) are:**

- secondary rated voltage of the current sensor used at the preset primary rated current (0...300 mV)
- primary rated current of the current sensor used (0...6000 A)
- amplitude correction factor of the current sensor used at rated current (0.9000...1.1000)
- correction parameter for the phase displacement error of the current sensor ( $-1.0000^\circ$ ... $1.0000^\circ$ )<sup>1</sup>

**Values to be set for a voltage divider are:**

- division ratio of the voltage divider primary and secondary voltage (0...20000)
- rated value of primary phase-to-phase voltage (0...440 kV)
- amplitude correction factor of the voltage divider (0.9000...1.1000)
- correction parameter for the phase displacement error of the voltage divider ( $-1.0000^\circ$ ... $1.0000^\circ$ )<sup>2</sup>

---

1. Only included in the machine terminal revisions of the Release 2.0 or later, refer to section "Revision identification" on page 85. Note that this parameter can only be set via the MMI or the Relay Setting Tool.

2. Only included in the machine terminal revisions of the Release 2.0 or later, refer to section "Revision identification" on page 85. Note that this parameter can only be set via the MMI or the Relay Setting Tool.

**Values to be set for general measurement:<sup>1</sup>**

- amplitude correction factor of general measurement  
(-10000.00000...10000.00000)
- correction parameter for the offset correction of general measurement  
(-10000.00000...10000.00000)

The measurement values stated by the manufacturer of the measuring device are used for calculating the correction parameters and factors according to the following formulas:

**Current transformers**

Amplitude error at current $I_n$ (e = error in per cent)	Amplitude correction factor 1 $= 1 / ( 1 + e/100 )$
Amplitude error at current $0.01 \times I_n$ (e = error in per cent)	Amplitude correction factor 2 $= 1 / ( 1 + e/100 )$
Phase displacement error at current $I_n$ (e = error in degrees)	Phase displacement error 1 = - e
Phase displacement error at current $0.01 \times I_n$ (e = error in degrees)	Phase displacement error 2 = - e

**Voltage transformers**

Amplitude error at voltage $U_n$ (e = error in per cent)	Amplitude correction factor $= 1 / ( 1 + e/100 )$
Phase displacement error at voltage $U_n$ (e = error in degrees)	Phase displacement error = - e

**Rogowski coil**

Amplitude error at the whole measuring range (e = error in per cent)	Amplitude correction factor $= 1 / ( 1 + e/100 )$
Phase displacement error at the whole measuring range (e = error in degrees)	Phase displacement error = - e

**Voltage divider**

Amplitude error at the whole measuring range (e = error in per cent)	Amplitude correction factor $= 1 / ( 1 + e/100 )$
Phase displacement error at the whole measuring range (e = error in degrees)	Phase displacement error = - e

---

1. Only included in the machine terminal revisions of the Release 2.0 or later, refer to section "Revision identification" on page 85.

**4.1.6.3.****Calculated analogue channels**

The REM 54\_ machine terminal includes virtual channels to obtain neutral current and residual voltage when sensors are used. Current sensors and voltage dividers are connected to the machine terminal via coaxial cables and therefore a residual connection of phase currents or an open-delta connection of phase voltages cannot be made. Both the amplitude and the phase angle are calculated for the virtual channels.

Though primarily meant to be used with sensors, the calculated analogue channels can also be used with conventional current and voltage transformers.

The neutral current  $I_0$  is numerically derived from the three phase currents:

$I_{os} = -(I_{L1} + I_{L2} + I_{L3})$ . Minus in front of the parenthesis means that the default direction of neutral current is assumed to be from the line to the busbar, while the normal power flow is from the busbar to the line.



When sensitive earth-fault protection is needed, core balance transformers are not recommended to be replaced with the numerically derived sum of phase currents. Normally, an earth-fault setting below 10% of the rated value requires the use of a core balance transformer.

The residual voltage  $U_0$  is numerically derived from the three phase voltages:

$U_{os} = (U_1 + U_2 + U_3) \div 3$ .  $U_{0S}$  is used instead of the open-delta connection when voltage dividers are used to measure phase-to-phase voltages.

If only one virtual channel is used, the channel will be numbered as 11. If both calculations are used, the  $I_{0S}$  channel will be given the number 11 and the  $U_{0S}$  channel the number 12.

**4.1.7.****Digital inputs**

The REM 543 and REM 545 machine terminals differ from each other regarding the number of digital inputs available.

The digital inputs of the REM 54\_ machine terminals are voltage-controlled and optically isolated. For technical data of the digital inputs, refer to Table 4.2.1.-3 on page 70.

The parameters for input filtering, input inversion and pulse counters (see sections below) can be set in the Configuration menu under each I/O card (e.g. Configuration/BIO1/Input filtering).

The events and parameters of I/O cards are included in the event and parameter lists on the CD-ROM “Technical Descriptions of Functions” (refer to section “References” on page 89).

**Table 4.1.7.-1 Digital inputs available for REM 54\_**

	REM 543	REM 545
Inputs	PS1_4_BI1 <sup>1)</sup>	PS1_4_BI1 <sup>1)</sup>
	PS1_4_BI2 <sup>1)</sup>	PS1_4_BI2 <sup>1)</sup>
	PS1_4_BI3 <sup>1)</sup>	PS1_4_BI3 <sup>1)</sup>
	BIO1_5_BI1	BIO1_5_BI1
	BIO1_5_BI2	BIO1_5_BI2
	BIO1_5_BI3	BIO1_5_BI3
	BIO1_5_BI4	BIO1_5_BI4
	BIO1_5_BI5	BIO1_5_BI5
	BIO1_5_BI6	BIO1_5_BI6
	BIO1_5_BI7	BIO1_5_BI7
	BIO1_5_BI8	BIO1_5_BI8
	BIO1_5_BI9 <sup>1)</sup>	BIO1_5_BI9 <sup>1)</sup>
	BIO1_5_BI10 <sup>1)</sup>	BIO1_5_BI10 <sup>1)</sup>
	BIO1_5_BI11 <sup>1)</sup>	BIO1_5_BI11 <sup>1)</sup>
	BIO1_5_BI12 <sup>1)</sup>	BIO1_5_BI12 <sup>1)</sup>
		BIO2_7_BI1
		BIO2_7_BI2
		BIO2_7_BI3
		BIO2_7_BI4
		BIO2_7_BI5
		BIO2_7_BI6
		BIO2_7_BI7
		BIO2_7_BI8
		BIO2_7_BI9 <sup>1)</sup>
		BIO2_7_BI10 <sup>1)</sup>
Digital inputs / total	15	25

1) These digital inputs can be programmed as either digital inputs or pulse counters, refer to section "Pulse counters" on page 42.

**4.1.7.1. Filter time of a digital input**

The filter time eliminates debounces and short disturbances on a digital input. The filter time is set for each digital input of the REM 54\_ machine terminal. The operation of input filtering is illustrated below.

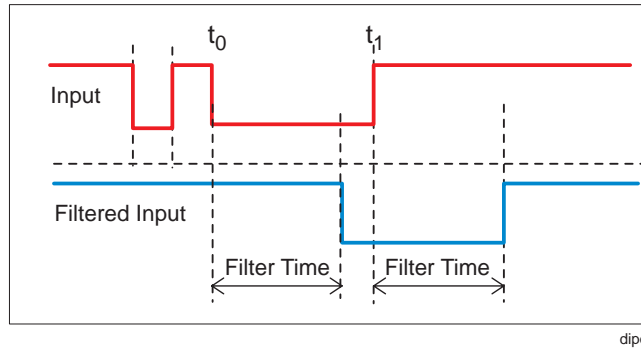

Fig. 4.1.7.1.-1 Filtering of a digital input

In the figure above, the input signal is named ‘Input’, the filter timer ‘Filter Time’ and the filtered input signal ‘Filtered Input’. At the beginning, the input signal is at high state, the short low state is filtered and no input status change is detected. The low state starting from the time  $t_0$  exceeds the filter time, which means that the change in the input status is detected and the time tag attached to the input change is  $t_0$ . The high state starting from  $t_1$  is detected and the time tag  $t_1$  is attached.

Each digital input has a filter time parameter “Input # filter”, where # is the number of the digital input of the module in question (e.g. Input 1 filter).

Parameter	Values	Default
Input # filter	1...65535 ms	5 ms

**4.1.7.2. Inversion of a digital input**

The parameter “Input # invert” can be used to invert a digital input:

Control voltage	Input # invert	Status of digital input
No	0	FALSE (0)
Yes	0	TRUE (1)
No	1	TRUE (1)
Yes	1	FALSE (0)

When the digital input is inverted, the status of the input is TRUE (1) when no control voltage is applied to its terminals. Accordingly, the input status is FALSE (0) when a control voltage is applied to the terminals of the digital input.

Parameter	Values	Default
Input # invert	0 (not inverted)	0
	1 (inverted)	

## 4.1.7.3.

**Pulse counters**

Some specific digital inputs (refer to section “Digital inputs” on page 39) of the REM 54\_ machine terminal can be programmed either as digital inputs or as pulse counters. This programming is done via the parameter “Input # mode” (in this parameter as well as in others mentioned below, # denotes the input number).

When an input operates as a digital input, no counting is done but the pulse counter value remains at the present value.

When an input operates as a pulse counter, the positive input transitions (0 -> 1) of a filtered input are counted and the counter value of “Input # counter” increases in the range 0... 2147483647. The pulse counters are updated with a period of 500 ms. The frequency range of a digital input parameterized to operate as a pulse counter is 0.....100 Hz.

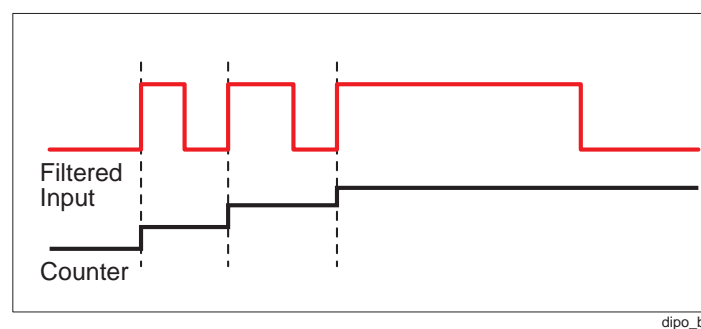

Fig. 4.1.7.3.-1 Principle of pulse counter function

The parameter “Input # preset” can be used to give a counter the start value. The start value is loaded into the counter by:

- writing the desired start value to the parameter “Input # preset”,
- writing the value 1 to the parameter “Counter trigger”. Then all the updated values of the “Input # preset” parameters are copied to the corresponding “Input # counter” parameters.

Writing the value 2 to the “Counter trigger” parameter copies all the “Input # preset” values to the corresponding “Input # counter” parameters. Writing the value 0 clears all the counters.

Parameter	Values	Default
Input # preset	0..... 2147483647	0
Input # mode	1 = digital input 2 = counter	1
Counter trigger	0 = clear all counters 1 = load updated Input # preset values 2 = load all Input # preset values	

**4.1.7.4.****Oscillation suppression**

Oscillation suppression is used to reduce the load from the system when, for some unrecognized reason, a digital input starts oscillating. A digital input is regarded as oscillating if the number of valid status changes (= number of events after filtering) during 1 second is greater than the set value “Input osc. level” (Oscillation level). During oscillation, the digital input is blocked (status is invalid) and an event is generated. The state of the input will not change when it is blocked, i.e. its state depends on the condition before blocking.

The digital input is regarded as non-oscillating if the number of valid status changes during 1 second is less than the set value of “Input osc. level” minus the set value of “Input osc. hyst.” (Oscillation hysteresis). Note that the oscillation hysteresis must be set lower than the oscillation level to enable the input to be restored from oscillation. When the input returns to a non-oscillating state, the digital input is deblocked (status is valid) and an event is generated.

Parameter	Values	Default
Input osc. level	2..50 events/s	50 events/s
Input osc. hyst.	2..50 events/s	10 events/s



Unlike most parameters for digital I/O cards, the parameters “Input osc. level” and “Input osc. hyst.” can be found in the menu Configuration/General.

**4.1.7.5.****Attributes of a digital input for machine terminal configuration**

The validity of the digital input (invalidity), the status of the input (value), the time tag for the status change (time) and the counter value of the input can be issued for each digital input by the attributes BI#IV, BI#, BI#Time and BI#Count, where # denotes the number of the input. These attributes are available in the machine terminal configuration and can be used for different purposes.

The example below shows how the attributes of the digital input 1 (PS1\_4\_BI1 on PS1 module) of the machine terminal REM 54\_ are named for the configuration:

PS1\_4\_BI1IV; digital input invalidity

PS1\_4\_BI1; digital input value

PS1\_4\_BI1Time; time tag

PS1\_4\_BI1Count; counter value

**Invalidity (BI#IV)**

When a digital input oscillates, the invalidity attribute IV changes to TRUE (1) and the input is blocked. The digital input is regarded as being blocked and oscillating if the number of status changes per second exceeds the set “Input osc. level” value (events/s).

When a digital input does not oscillate, the invalidity attribute IV changes to FALSE (0) and the input becomes operative. The digital input is regarded as being operative and non-oscillating if the number of status changes per second is less than the set “Input osc. level” value minus the set “Input osc. hyst.” value (events/s).

**Value (BI#)**

Depending on the status of the digital input, the digital input value is TRUE (1) or FALSE (0). The BI# value changes on the rising or falling edge of the input. To prevent undesired status changes of the digital input due to switch debouncing, etc., the change of the attribute value is delayed by the filter time.

The counter attribute of a digital input is not updated when the input is programmed as a normal digital input.

**Time (BI#Time)**

Each change (rising or falling edge) detected in the status of a digital input is time-tagged at an accuracy of  $\pm 1$  ms. The time tag represents the moment (time) of the latest input change of the value attribute. The time is not recorded until the filtering time of the status change has elapsed, which means that the filtering time does not affect the time tag value.

**Count (BI#Count)**

The count attribute indicates the number of positive input transitions of a filtered input.

**4.1.8.****Digital outputs**

The outputs of the REM 54\_ machine terminal are categorized as follows:

- HSPO High-speed power output, double-pole contact, preferred for tripping purposes and for circuit breaker and disconnect control
- PO Power output, either single-pole or double-pole contact, preferred for circuit breaker and disconnect control
- SO Signal output, either NO (Normally Open) or NO/NC (Normally Open/ Normally Closed) contact

The events and parameters of I/O cards are included in the event and parameter lists on the CD-ROM "Technical Descriptions of Functions" (refer to section "References" on page 89).

For information about terminal connections for the outputs, refer to terminal diagrams (beginning on page 75), where all the outputs are included with relay connector terminals.

For technical data of the outputs, see Table 4.2.1.-6 on page 71.

**Table 4.1.8.-1 Digital outputs**

	REM 543	REM 545
Outputs	PS1_4_HSPO1 <sup>1)</sup>	PS1_4_HSPO1 <sup>1)</sup>
	PS1_4_HSPO2 <sup>1)</sup>	PS1_4_HSPO2 <sup>1)</sup>
	PS1_4_HSPO3	PS1_4_HSPO3
	PS1_4_HSPO4	PS1_4_HSPO4
	PS1_4_HSPO5	PS1_4_HSPO5
	PS1_4_SO1	PS1_4_SO1
	BIO1_5_SO1	BIO1_5_SO1
	BIO1_5_SO2	BIO1_5_SO2
	BIO1_5_SO3	BIO1_5_SO3
	BIO1_5_SO4	BIO1_5_SO4
	BIO1_5_SO5	BIO1_5_SO5
	BIO1_5_SO6	BIO1_5_SO6
		BIO2_7_PO1
		BIO2_7_PO2
		BIO2_7_PO3
		BIO2_7_PO4
		BIO2_7_PO5
		BIO2_7_PO6
Outputs / total	12	18

<sup>1)</sup> Trip Circuit Supervision function included

**4.1.8.1.**

**High-speed double-pole power outputs (HSPO)**

The high-speed power outputs PS1\_4\_HSPO1 ... PS1\_4\_HSPO5 can be connected as double-pole outputs where the object to be controlled (e.g. a circuit breaker) is electrically connected between the two relay contacts, see the figure below. The high-speed double-pole power output is recommended to be used for tripping purposes.



When TCS is used (see Table 4.1.8.-1 on page 45), the outputs are connected as shown in Figure 4.1.11.-1 on page 60.

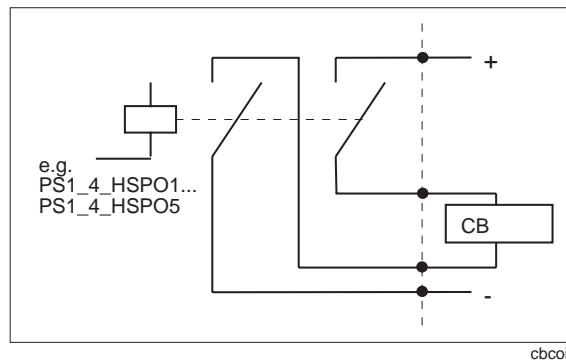

*Fig. 4.1.8.1.-1 High-speed double-pole power outputs (HSPO)*

The high-speed power outputs PS1\_4\_HSPO1 ... PS1\_4\_HSPO5 can also be connected as single-pole power outputs where the object to be controlled (e.g. a circuit breaker) is electrically connected in series with the two relay contacts, see the figure below.

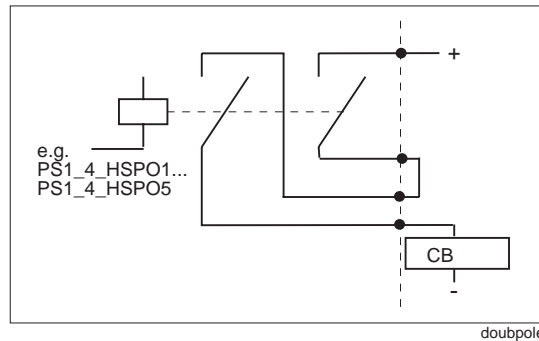

Fig. 4.1.8.1.-2 High-speed single-pole power outputs (HSPO)

4.1.8.2.

**Single-pole power outputs (PO)**

The single-pole power outputs BIO2\_7\_PO1 and BIO2\_7\_PO2 are outputs where the object to be controlled is connected in series with two heavy-duty output relay contacts, see the figure below. These outputs can be used for tripping purposes and for circuit breaker and disconnector control.

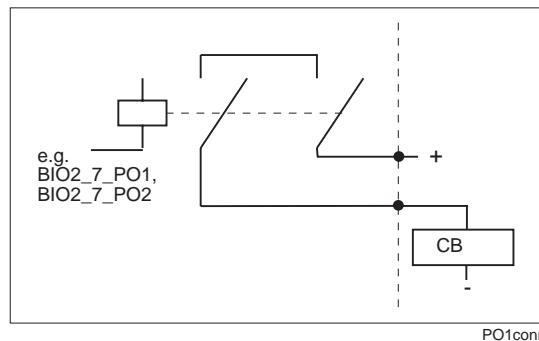
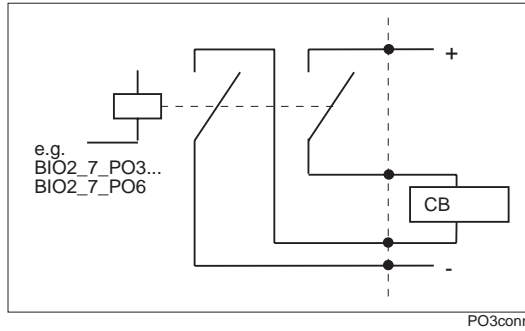

Fig. 4.1.8.2.-1 Single-pole power outputs (PO)

**4.1.8.3. Double-pole power outputs (PO)**

The double-pole power outputs BIO2\_7\_PO3 ... BIO2\_7\_PO6 are outputs where the object to be controlled (e.g. a circuit breaker) is electrically connected between the two relay contacts, see the figure below. These outputs can be used for tripping purposes and for circuit breaker and disconnector control.



*Fig. 4.1.8.3.-1 Double-pole power outputs (PO)*

If the power outputs BIO2\_7\_PO3 ... BIO2\_7\_PO6 are used as single-pole outputs, the object to be controlled (e.g. a circuit breaker) is electrically connected in series with the two relay contacts to provide sufficient current breaking capacity, see the figure below.

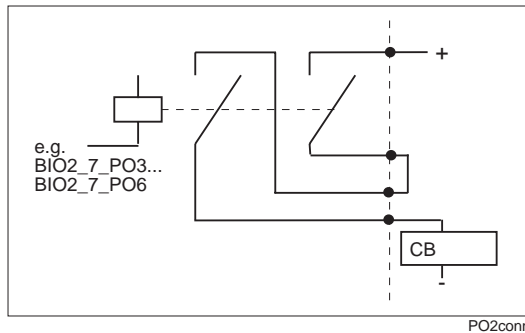

*Fig. 4.1.8.3.-2 Single-pole power outputs (PO)*

#### 4.1.8.4. Signal outputs (SO)

The signalling relay outputs (BIO1\_5\_SO\_) are not heavy-duty outputs and thus they cannot be used for controlling e.g. a circuit breaker. Available relay contacts are either Normally Open or Normally Open/Normally Closed type (NO or NO/NC), see the figure below. These outputs can be used for alarming and other signalling purposes.

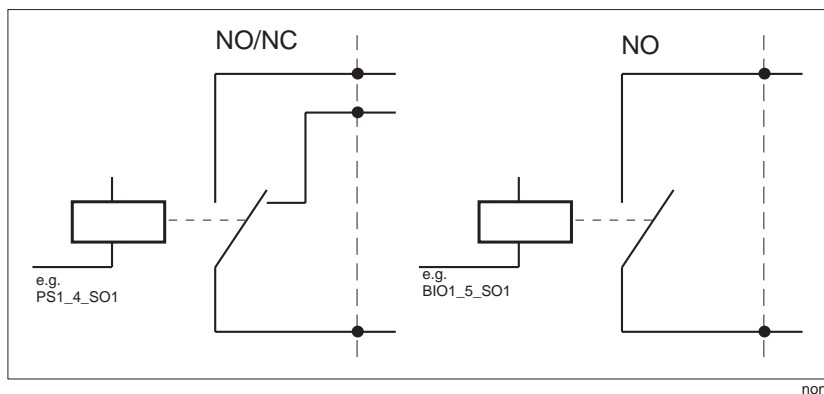

Fig. 4.1.8.4.-1 Signal outputs (SO)

#### 4.1.9. RTD/analogue inputs

The REM 543 and REM 545 machine terminals equipped with an RTD/analogue module (RTD1) have eight general purpose analogue inputs for DC measurement. The RTD/analogue inputs are galvanically isolated from the machine terminal power supply and enclosure. However, the inputs share a common ground.

For technical data of the RTD/analogue inputs, refer to Table 4.2.1.-4 on page 71.

	REM 543/REM 545 + RTD1
RTD/analogue inputs	RTD1_6_AI1
	RTD1_6_AI2
	RTD1_6_AI3
	RTD1_6_AI4
	RTD1_6_AI5
	RTD1_6_AI6
	RTD1_6_AI7
	RTD1_6_AI8

The parameters for the RTD/analogue inputs are included in the parameter lists on the CD-ROM “Technical Descriptions of Functions” (refer to section “References” on page 89).

##### 4.1.9.1. Selection of input signal type

The general purpose RTD/analogue inputs accept voltage-, current- or resistance-type signals. The inputs are configured for a particular type of input signal by means of the channel-specific “Input mode” parameters that can be found in the menu Configuration/RTD1/Input # . The default value is “Off” which means that the channel is not sampled at all, and the IN+, IN- and SHUNT terminals are at high impedance state.

Parameter	Values	Default
Input mode	0 = Off	Off
	1 = Voltage	
	2 = Current	
	3 = Resistance 2W <sup>1)</sup>	
	4 = Resistance 3W <sup>2)</sup>	
	5 = Temperature 2W <sup>1)</sup>	
	6 = Temperature 3W <sup>2)</sup>	

1) Two-wire measurement

2) Three-wire measurement

#### 4.1.9.2.

#### Selection of input signal range

For each measuring mode, a separate parameter is provided for choosing between the available measurement ranges. These channel-specific parameters, which can be found in the menu Configuration/RTD1/Input #, are named “Voltage range”, “Current range”, “Resistance range” and “Temperature range”. All range parameters can be set but only one is used. The value of the “Input mode” parameter determines which range parameter is used. The “Temperature range” parameter also defines the sensor type to be used, e.g. PT100.

Parameter	Values	Default
Voltage range	0 = 0...1V	0...1 V
	1 = 0...5 V	
	2 = 1...5 V	
	3 = 0...10 V	
	4 = 2...10 V	
	5 = -5...5 V	
	6 = -10...10 V	
Current range	0 = 0...1 mA	0...1 mA
	1 = 0...5 mA	
	2 = 1...5 mA	
	3 = 0...10 mA	
	4 = 0...20 mA	
	5 = 4...20 mA	
	6 = -1...1 mA	
	7 = -2.5...2.5 mA	
	8 = -5...5 mA	
	9 = -10...10 mA	
	10 = -20...20 mA	
Resistance range	0 = 0...100 Ω	0...100 Ω
	1 = 0...200 Ω	
	2 = 0...500 Ω	
	3 = 0...1000 Ω	
	4 = 0...2000 Ω	
	5 = 0...5000 Ω	
	6 = 0...10000 Ω	

Parameter	Values	Default
Temperature range	0 = Pt100 -45...150 °C	Pt100 -45..150 °C
	1 = Pt100 -45...600 °C	
	2 = Pt250 -45...150 °C	
	3 = Pt250 -45...600 °C	
	4 = Pt1000 -45...150 °C	
	5 = Pt1000 -45...600 °C	
	6 = Ni100 -45...150 °C	
	7 = Ni100 -45...250 °C	
	8 = Ni120 -45...150 °C	
	9 = Ni120 -45...250 °C	
	10 = Ni250 -45...150 °C	
	11 = Ni250 -45..250 °C	
	12 = Ni1000 -45...150 °C	
	13 = Ni1000 -45...250 °C	
	14 = Cu10 -45...150 °C	

#### 4.1.9.3.

#### Transducer supervision

The measuring signal level of each transducer is constantly supervised. If the measured signal falls more than 4% below or rises more than 4% over the specified input signal range of a particular channel, the transducer or the transducer wiring is considered to be faulty and the channel-specific invalid signal is immediately activated. The invalid signal is deactivated as soon as the transducer signal is within the valid range.

When necessary, the valid measuring range may be narrower than the default -4..104% of the selected measuring range. A narrower range can be defined by means of the parameters “Input high limit” and “Input low limit” that can be found in the menu Configuration/RTD1/Input # .

Parameter	Values	Default
Input low limit	-4...104 %	-4 %
Input high limit	-4...104 %	104 %

When an input is configured for resistance or temperature measurement, the internal excitation current generator forces a current pulse through the measuring circuit when the input is sampled. If the actual current level does not match the programmed level due to too high impedance in the circuit, the invalid signal is immediately activated. The invalid signal is deactivated as soon as the circuit resistance is low enough.

#### 4.1.9.4. Signal filtering

Short disturbances on an input are eliminated by signal filtering. The filter time, which defines the step response time, is set for each transducer input of the machine terminal by the “Filter time” parameters in the menu Configuration/RTD1/Input # . The filtering algorithm is a so-called median filter which shows no reaction to interference spikes but levels out directly on permanent changes.

Parameter	Values	Default
Filter time	0 = 0.4 s 1 = 1 s 2 = 2 s 3 = 3 s 4 = 4 s 5 = 5 s	5 s

#### 4.1.9.5. Input scaling/linearization<sup>1</sup>

The user can scale each RTD/analogue input linearly or non-linearly by constructing a separate linearization curve for each input. The name implies the typical use, i.e. the linearization of not directly supported non-linear sensors. The curve consists of at least two (for linear scaling) and up to ten points, where the x-axis of the curve is 0 to 1000 per mille of the range selected for the input and the y-axis is the scaled absolute value of the input. The linearization curves can be enabled and disabled with the “Linear. curve” parameters in the menu Configuration/RTD1/Input # . The curve is constructed and downloaded to the machine terminal by using a special tool in the relay toolbox.

Parameter	Values	Default
Linear. curve	0 = Disabled 1 = Enabled	Disabled

When the linearization curve is enabled, the “Input high limit” and “Input low limit” parameters affect the scaled range instead of the range selected by the parameters. The range of the scaled input is defined as the range between the smallest y-axis value and the largest y-axis value.

---

1. Not supported yet in Release 2.0

**4.1.9.6. Transducer connections**

The RTD/analogue inputs may be connected to a large variety of different measuring transducer types, both standardized and customer-specified types.

Three connection screws have been reserved for each channel. Further, one connection screw (analogue ground) has been reserved per every two channels.

Two earth terminals (see figure below), located to the left of the connectors, are reserved for connecting the protective sheaths of the transducer input cables. The cable sheath is generally earthed in one end of the cable only.

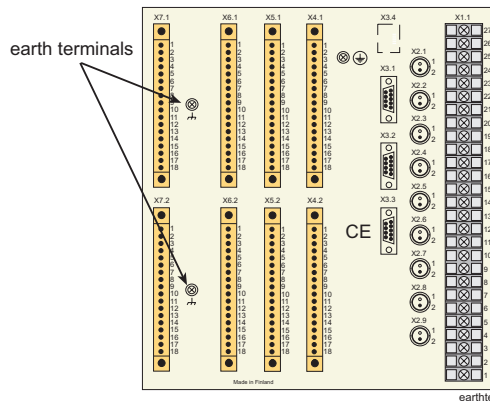

Fig. 4.1.9.6.-1 Earth terminals

**Current transducers**

When a current transducer is connected to the RTD/analogue input, the SHUNT and IN+ terminals are linked together as are the GND and IN- terminals. The incoming current signal is connected to the IN+ terminal and the outgoing current signal to the IN- terminal.

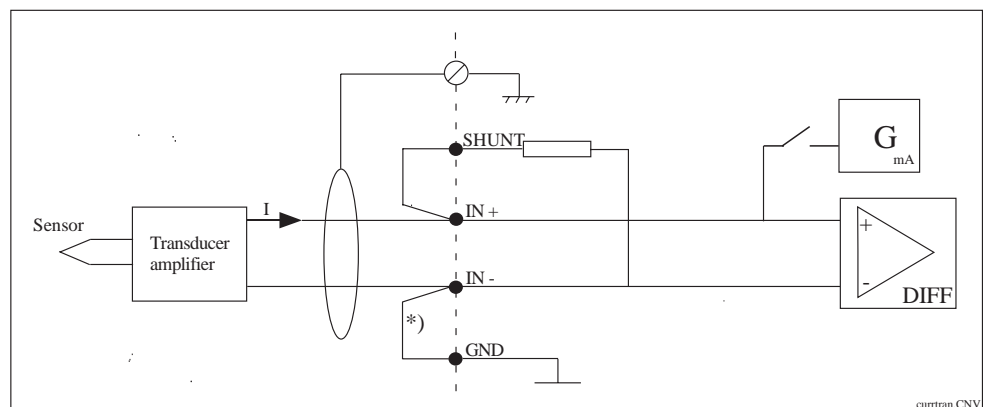

Fig. 4.1.9.6.-2 Principle diagram for the connection of current transducers

**Voltage transducers**

When a voltage transducer is connected to the RTD/analogue input, the GND and IN- terminals are linked together. The incoming voltage signal is connected to the IN+ terminal and the return voltage signal lead to the IN- terminal.

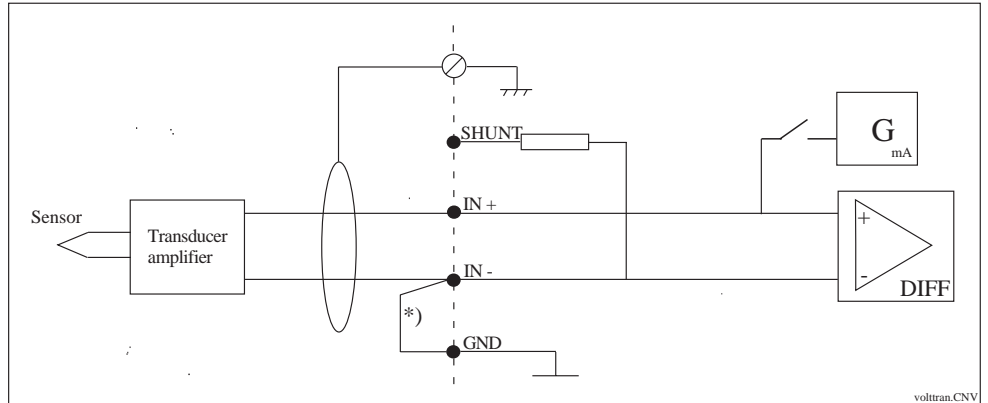

Fig. 4.1.9.6.-3 Principle diagram for the connection of voltage transducers

\*) The GND terminals are galvanically isolated from the supply and enclosure of the machine terminal, but they are all connected to each other, i.e. they share the same potential. When several inputs are connected to single-ended signal sources that share a common ground, ground loops result if the connection GND <-> IN- is done on every input. In this situation, the connection GND <-> IN- is done on only one of the concerned RTD/analogue inputs.

**Resistance sensors**

The resistance sensors may be connected to the RTD/analogue input according to either the three-wire or the two-wire connection principle. With the three-wire measuring principle, the wire resistance is automatically compensated. The resistor, or RTD sensor, is connected across the IN+ and IN- inputs, and the - side of the resistor/RTD sensor is connected to the GND input. The leads connected to the IN+ and GND inputs must be of the same type.

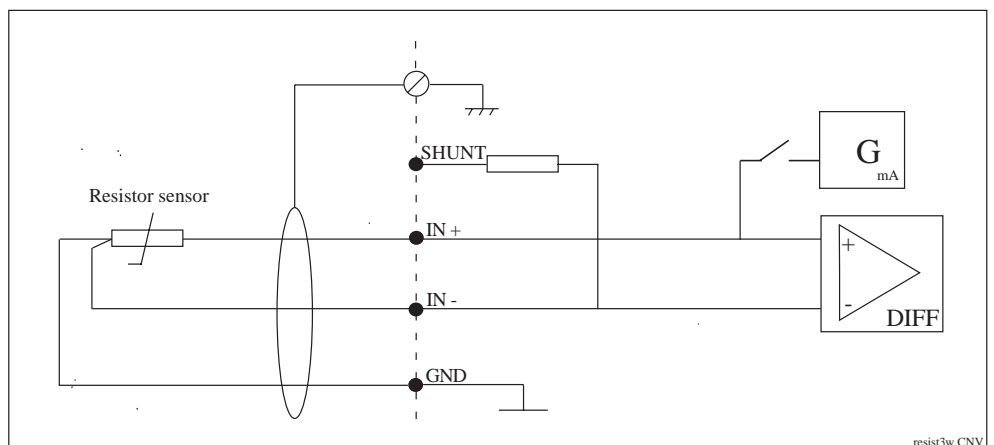

Fig. 4.1.9.6.-4 Principle diagram of the three-wire connection

With the two-wire connection principle, the IN- and GND terminals are linked together. The resistor is connected across the IN+ and IN- inputs.

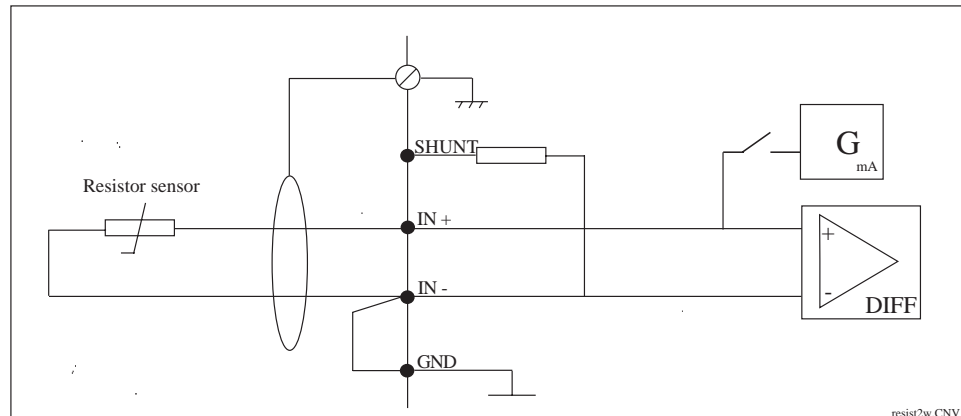

Fig. 4.1.9.6.-5 Principle diagram of the two-wire connection

#### 4.1.9.7.

### Attributes of an RTD/analogue input for machine terminal configuration

The value and the status (validity) of the input can be issued for each RTD/analogue input by the attributes AI# (REAL type) and AI#IV (BOOL type), where # denotes the number of the input. These attributes are available in the machine terminal configuration and can be used for different purposes.

#### Value (AI#)

The AI# value represents the filtered absolute value of the physical input with the unit according to the selected measuring mode, i.e. V, mA,  $\Omega$  or  $^{\circ}\text{C}$ .

#### Invalidity (AI#IV)

The AI#IV attribute represents the invalidity status of the input. The attribute is set to FALSE when the value (AI#) is valid, and to TRUE when the value is invalid. The input is invalid when one or more of the following conditions are true: the measured value is outside the defined limits (see the parameters “Input high limit” and “Input low limit”), an open-loop condition is detected (only possible on resistance and temperature measuring modes) or the continuous recalibration of the module has failed. The value (AI#) is not locked when the invalid attribute is set to TRUE, i.e. the invalid value is available for inspection.

#### 4.1.9.8.

### RTD/analogue input configuration example

The RTD/analogue inputs are supported in the Relay Configuration Tool by the general measurement function blocks MEAI1...MEAI8. As an example, to monitor temperature using a PT100 sensor, the measured value of the RTD/analogue input is connected to the function block by connecting the value attribute RTD1\_6\_AI1 to the RawAI input of the function block. The output HighAlarm is used to activate a relay contact when the temperature exceeds a preset limit. The measured temperature is displayed on the MIMIC view of the MMI by the connected

MMIDATA1 function block. To avoid unnecessary activation of the relay contact in case of a fault, the corresponding invalid attribute of the RTD/analogue input RTD1\_6\_AI1IV is connected to the IV input of the function block.

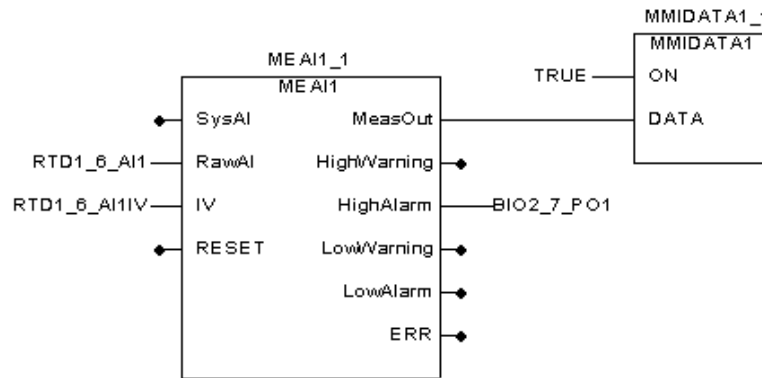

Fig. 4.1.9.8.-1 RTD/analogue input configuration example

#### 4.1.9.9.

### Self-supervision

Each input sample is validated before it is fed into the filter algorithm. The samples are validated by measuring an internally set reference voltage immediately after the inputs are sampled. If the measured offset voltage deviates from the set value more than 1.5% of the measuring range, the sample is discarded. If the fault continues longer than for the set filter time, the invalid attributes of all inputs are set to TRUE to indicate a hardware fault. Should the measurement succeed later, the invalid attributes are reset to FALSE. This prevents most sudden hardware faults from affecting the measured value before the invalid attribute is set. To ensure that the specified measurement accuracy is met, a more thorough test of the hardware is performed by the continuous recalibration procedure which will catch errors that degrade the measurement accuracy.

#### 4.1.9.10.

### Calibration

The RTD/analogue module is calibrated at the factory. To be able to maintain the specified accuracy in spite of aging and varying temperature, the card also includes special hardware to allow self-recalibration on the field. This recalibration procedure runs continuously, even when no measurements are activated, to ensure that the card is always optimally calibrated. If the recalibration procedure fails, the reason is a hardware failure. In this case the card's measurement accuracy is no longer obtained, and the invalidity attributes of all inputs are set to TRUE. However, the card continues updating the measured input values, and if the invalidity attributes are not used in the machine terminal configuration, the situation could go unnoticed. Should the recalibration succeed later, the invalidity attributes return to normal operation.

**4.1.9.11. RTD temperature vs. resistance**

For the resistance values of temperature sensors at specified temperatures, see table below.

TEMP C°	Platinum TCR 0.00385			Nickel TCR 0.00618				Copper TCR 0.00427
	Pt 100	Pt 250	Pt 1000	Ni 100	Ni 120	Ni 250	Ni 1000	Cu 10
-40.0	84.27	210.675	842.7	79.1	94.92	197.75	791	7.490
-30.0	88.22	220.55	882.2	84.1	100.92	210.25	841	-
-20.0	92.16	230.4	921.6	89.3	107.16	223.25	893	8.263
-10.0	96.09	240.225	960.9	94.6	113.52	236.5	946	-
0.0	100.00	250	1000	100.0	120	250	1000	9.035
10.0	103.90	259.75	1039	105.6	126.72	264	1056	-
20.0	107.79	269.475	1077.9	111.2	133.44	278	1112	9.807
30.0	111.67	279.175	1116.7	117.1	140.52	292.75	1171	-
40.0	115.54	288.85	1155.4	123.0	147.6	307.5	1230	10.580
50.0	119.40	298.5	1194	129.1	154.92	322.75	1291	-
60.0	123.24	308.1	1232.4	135.3	162.36	338.25	1353	11.352
70.0	127.07	317.675	1270.7	141.7	170.04	354.25	1417	-
80.0	130.89	327.225	1308.9	148.3	177.96	370.75	1483	12.124
90.0	134.70	336.75	1347	154.9	185.88	387.25	1549	-
100.0	138.50	346.25	1385	161.8	194.16	404.5	1618	12.897
120.0	146.06	365.15	1460.6	176.0	211.2	440	1760	13.669
140.0	153.58	383.95	1535.8	190.9	229.08	477.25	1909	14.442
150.0	-	-	-	198.6	238.32	496.5	1986	-
160.0	161.04	402.6	1610.4	206.6	247.92	516.5	2066	15.217
180.0	168.46	421.15	1684.6	223.2	267.84	558	2232	-
200.0	175.84	439.6	1758.4	240.7	288.84	601.75	2407	-
220.0	-	-	-	259.2	311.04	648	2592	-
240.0	-	-	-	278.9	334.68	697.25	2789	-
250.0	194.07	485.175	1940.7	289.2	347.04	723	2892	-
300.0	212.02	530.05	2120.2	-	-	-	-	-
350.0	229.67	574.175	2296.7	-	-	-	-	-
400.0	247.04	617.6	2470.4	-	-	-	-	-
450.0	264.11	660.275	2641.1	-	-	-	-	-
500.0	280.90	702.25	2809	-	-	-	-	-
550.0	297.39	743.475	2973.9	-	-	-	-	-
600.0	313.59	783.975	3135.9	-	-	-	-	-

#### 4.1.10. Analogue outputs

The REM 543 and REM 545 machine terminals equipped with an RTD/analogue module have four general purpose 0...20 mA analogue current outputs. All outputs are galvanically isolated from the supply and enclosure of the machine terminal and from each other.

For technical data of the analogue outputs, refer to Table 4.2.1.-7 on page 72.

	REM543/REM545 + RTD1
Analogue outputs	RTD1_6_AO1
	RTD1_6_AO2
	RTD1_6_AO3
	RTD1_6_AO4

The parameters and events for the analogue outputs are included in the event and parameter lists on the CD-ROM “Technical Descriptions of Functions” (refer to section “References” on page 89).

##### 4.1.10.1. Selection of analogue output range

The outputs can be set to two different current ranges with the “Output range” parameters in the menu Configuration/RTD1/Output # .

Parameter	Values	Default
Output range	0 = 0...20 mA 1 = 4...20 mA	0...20 mA

##### 4.1.10.2. Attributes of an analogue output for machine terminal configuration

The status (value) and the validity of the output can be issued for each analogue output by the attributes AO# (REAL type) and AO#IV (BOOL type), where # denotes the number of the output. These attributes are available in the machine terminal configuration and can be used for different purposes.

###### Value (AO#)

The value written to AO# is transferred to a current signal at the output. The output response time is  $\leq 85$  ms, consisting of the software delay and the rise time of the analogue output, counted from the moment when the value attribute is updated in the configuration program.

###### Invalidity (AO#IV)

The AO#IV attribute represents the invalidity status of the output. The attribute is set to FALSE when the value (AO#) is valid, i.e. an equal amount of current is flowing through the output, and to TRUE when the value is invalid, i.e. the current at the output is different from the value of AO#. When the AO#IV attribute is TRUE, this indicates one of two situations: either the current loop connected to the output is broken or the value attribute is written with a value outside the range defined by

the “Output range” parameter. The transition of the AO#IV state may also generate an event. Event generation is controlled by the “Event mask” parameter found in the menu Configuration/RTD1

The output behaviour when the value attribute is outside the defined limits is as follows:

Output range	Value of AO#	Output current	Invalidity attribute AO#IV
0...20 mA	>20	20 mA	TRUE
	0..20	0...20 mA	FALSE
	<0	0 mA	TRUE
4...20 mA	>20	20 mA	TRUE
	4..20	4...20 mA	FALSE
	<4	0 mA	TRUE

Note that the output is also forced to 0 mA on the 4..20 mA range when the value is below the low limit. This behavior can be used to indicate a fault to the receiver.

4.1.10.3.

**Analogue output configuration example**

The analogue outputs are supported in the Relay Configuration Tool by the MEAO1...MEAO4 analogue output function blocks. As an example, to display the measured value of neutral current on an analogue gauge, the neutral current measurement block MECU1A is connected to MEAO1, which in turn is connected to the RTD1\_6\_AO1 global variable. The output invalid signal RTD1\_6\_AO1IV is connected to the MMIALAR1 function block to achieve a visual indication of a fault. The MEAO# function blocks contain the parameters necessary for scaling the measured value to fit the selected output range. The MEAO# function blocks also limit the output change frequency to achieve a tolerable system load.

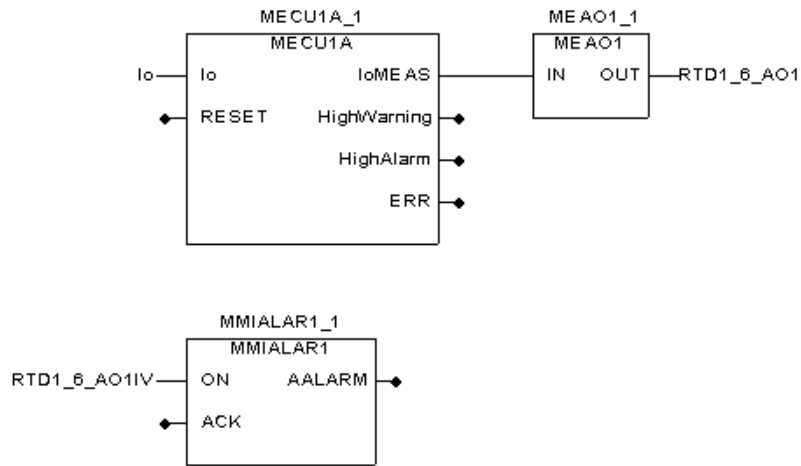

Fig. 4.1.10.3.-1 Analogue output configuration example

**4.1.11.****Trip circuit supervision**

The trip circuit supervision inputs TCS1 and TCS2 in the REM 54\_ machine terminal consist of two functional units:

- a constant-current generator including the necessary hardware elements
- a software-based functional unit for signalling

The functional units are based on the CMTCS1 and CMTCS2 function blocks included in the condition monitoring category.

The supervision of the trip circuit is based on the constant-current injection principle. If the resistance of the trip circuit exceeds a certain limit, for instance due to bad contact or oxidation, or if the contact has welded, the voltage over the supervised contact falls below 20 V ac/dc (15...20V) and the supervision function of the trip circuit is activated. If the fault persists, the trip circuit supervision alarm signal ALARM is obtained once the preset delay time of the function block CMTCS\_ elapses.

The input/output circuits are galvanically isolated from each other. The constant-current generator forces a 1.5 mA measuring current through the circuit-breaker trip circuit. The constant current generator is connected over the trip contact of the machine terminal circuit. The current generator for the TCS1 is connected to the terminals X4.1/12-13 and the current generator for the TCS2 to the terminals X4.1/17-18 of the REM 54\_ machine terminal.

Under no-fault conditions, the voltage over the contact of the constant current generator must be above 20 V ac/dc.

Mathematically, operating condition can be expressed as:

$$U_c - (Rh_{ext} + Rh_{int} + R_s) \cdot I_c \geq 20Vac/dc$$

where

- $U_c$  = operating voltage over the supervised trip circuit
- $I_c$  = measuring current through the trip circuit, approximately 1.5 mA (0.99 ... 1.72 mA)
- $Rh_{ext}$  = external shunt resistor value
- $Rh_{int}$  = internal shunt resistor value, 1 k $\Omega$
- $R_s$  = trip coil resistance value

The resistor  $Rh_{ext}$  must be so calculated that the trip circuit supervision current through the resistor is low enough not to influence the trip coil of the circuit breaker. On the other hand, the voltage drop over the resistor  $Rh_{ext}$  must be low enough not to jeopardize the operating condition presented in the formula above.

The following values are recommended for the resistor  $R_{h_{ext}}$  in Figure 4.1.11.-1 below:

Operating voltage $U_c$	Shunt resistor $R_{h_{ext}}$
48 V dc	1.2 k $\Omega$ , 5 W
60 V dc	5.6 k $\Omega$ , 5 W
110 V dc	22 k $\Omega$ , 5 W
220 V dc	33 k $\Omega$ , 5 W

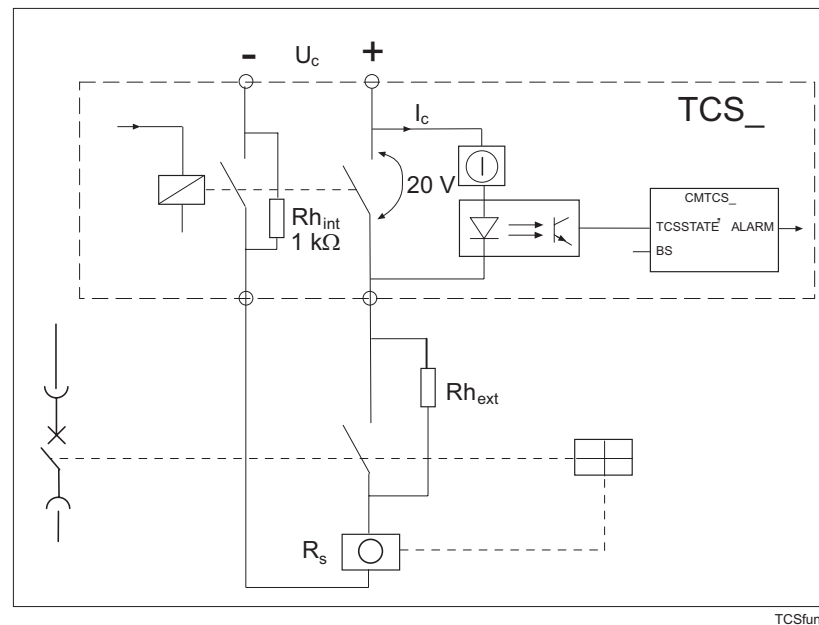

Fig. 4.1.11.-1 Operating principle of the trip circuit supervision (TCS) function

### 4.1.11.1.

### Configuring the trip circuit supervision CMTCS\_

The Relay Configuration Tool can be used to connect the trip circuit supervision input status signals to the function blocks CMTCS1 and CMTCS2. The configuration of the blocking signal is user-specific and can only be defined in the machine terminal configuration. The trip circuit supervision inputs in the machine terminal configuration are as follows:

TCS1 and TCS2 inputs in REM 543 and REM 545:

Trip Circuit Supervision 1 input	PS1_4_TCS1
Trip Circuit Supervision 2 input	PS1_4_TCS2

For more information about the trip circuit supervision function, refer to the Technical Descriptions of Functions for CMTCS1 and CMTCS2 (1MRS750889-MCD).

## 4.1.12. Self-supervision (IRF)

The REM 54\_ machine terminal is provided with an extensive self-supervision system. The self-supervision system handles run-time fault situations and informs the user of faults via the MMI and LON/SPA communication. See also Table 4.2.1.-12 on page 74.

### 4.1.12.1. Fault indication

The self-supervision signal output operates on the closed circuit principle. Under normal conditions the output relay is energized and the contact gap 3-5 is closed. Should the auxiliary power supply fail or an internal fault be detected, the contact gap 3-5 is opened.

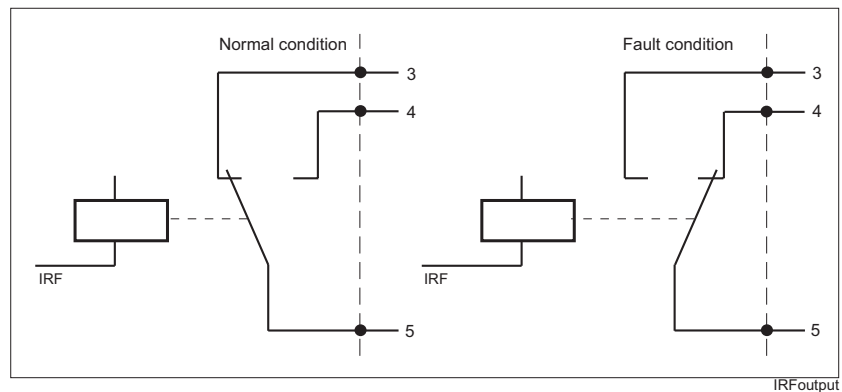

Fig. 4.1.12.1.-1 Self-supervision output (IRF)

When a fault has been detected, the green Ready indicator starts blinking, a fault indication text is displayed on the MMI and an event E57 is generated over serial communication. The fault indication text on the MMI consists of two rows as shown below:

SELF SUPERVISION
*INTERNAL FAULT*

Fault indication has the highest priority on the MMI and cannot be overrun by any other MMI indication. The fault indication text is displayed until cleared by pressing the C button for 2 seconds. Then the green READY indicator still remains blinking.

If the internal fault disappears the fault indication text remains on the display unless it has been cleared, but the green READY indicator stops blinking. In addition, an event E56 is generated over the serial communication.

### 4.1.12.2. Fault codes

When an internal fault appears in REM 54\_, the self-supervision system generates an IRF code that indicates the type of the fault. The fault code can be read from the machine terminal main menu Status/General/IRF code. The code indicates the first internal fault detected by the self-supervision system.



Do not reset the machine terminal before reading the IRF code. The code should be noted in the service report (refer to page 96) when overhaul is ordered.

The following table gives an overview of the fault origin.

Codes	Explanation
0 ->	Faults related to a module of the machine terminal, e.g. the MIMIC card, BIO card or RTD/analogue module
3000 ->	Faults related to the parameter database
6000 ->	Faults related to the analogue measurement inputs
7000 ->	Software faults
15000 ->	Faults related to testing

### 4.1.13. Serial communication

The machine terminal has two serial communication ports, one on the front panel and the other on the rear panel.

The standard ABB optical connector (RS-232 connection) on the front panel is intended for the connection of a PC for configuring the machine terminal with the CAP 50\_ tools. The front interface uses the SPA bus protocol.

The 9-pin D-type subminiature connector (RS-485 connection) on the rear panel connects the machine terminal to the distribution automation system via the SPA bus or the LON bus. The fibre-optic interface module type RER 103 is used to connect the machine terminal to the fibre-optic communication bus. The module RER 103 supports both SPA bus and LON bus communication.

#### 4.1.13.1. LON/SPA bus communication on the rear connector X3.3

The machine terminal supports both SPA bus protocol and LON bus communication. The bus communication protocol for the rear interface RS-485 (connector X3.3) is selected via the “Protocol 3” setting parameter in the menu Communication/General.

#### 4.1.13.2. Front panel optical RS-232 connection for a PC

The optical connector on the front panel isolates the PC galvanically from the machine terminal. The front connector for the PC is standardized for ABB relay products and requires a specific opto-cable (ABB art. No 1MKC950001-1). The cable is connected to the serial RS-232 port of the PC. The other communication parameters for the rear RS-485 interface are also set in the Communication menu of the REM 54\_ machine terminal.

#### 4.1.13.3. Communication parameters

The SPA bus protocol uses an asynchronous serial communication protocol (1 start bit, 7 data bits + even parity, 1 stop bit) with adjustable data transfer rate; Baud rate (default 9.6 kbps) and SPA address (slave number).

The SPA communication parameters are the same for communication via the front optical RS-232 and the rear RS-485 connectors. The SPA address is the same also for transparent SPA communication on the LON.

Adjustable LON serial communication parameters are Subnet number, Node number and Bit rate.

The SPA address and the Subnet/Node number on the LON are used for identifying the device from the protocol point of view and they are independent of each other.

For more information, see Table 4.2.1.-11 on page 73.

#### 4.1.13.4. Parallel communication support

When SPA is used, the rear side communication is not stopped when the front connector is “active”. This enables e.g. uploading the disturbance records without affecting the communication to upper level.

Moreover, if LON is selected as a communication protocol and the front connector is “active”, transparent SPA write commands are not inhibited via the LON bus.<sup>1</sup>

#### 4.1.13.5. System structure

The system very often resembles the system in the figure below. Generator or motor feeders are protected and controlled with REM 54\_ machine terminals. Some protection, control or alarm functions are implemented by using REF 54\_ feeder terminals, SPACOM units or other SPA bus devices (devices connected to the system via the SPA bus). LON devices made by other manufacturers or other ABB companies may be used for various DI, AI and DO functions. MicroSCADA is used for remote control.

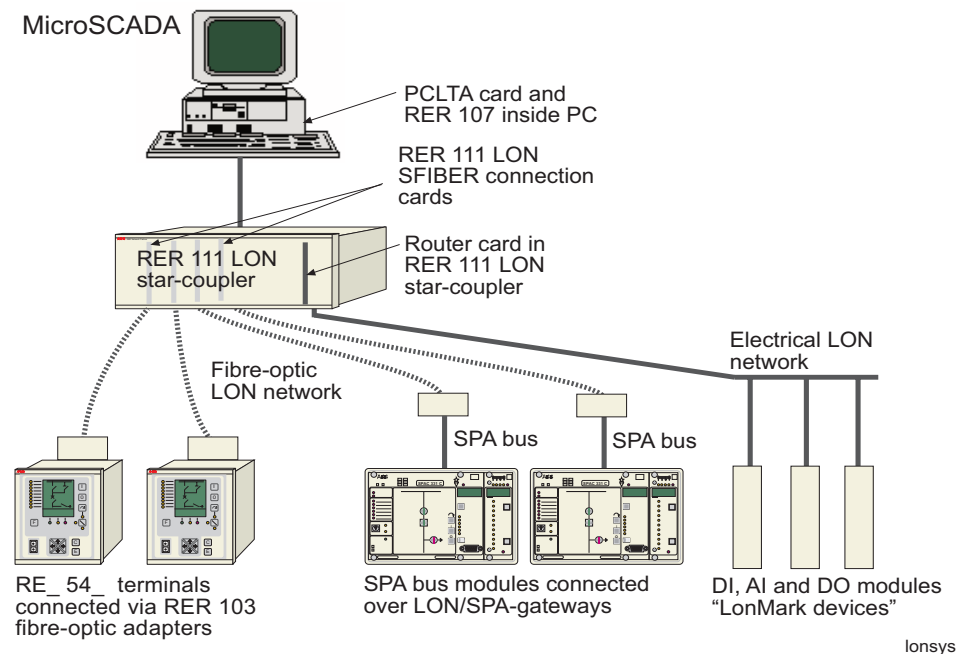

Fig. 4.1.13.5.-1 Example of a LON-based substation automation system

1. Parallel communication is restricted in releases prior to Release 2.0, refer to section “Release 2.0” on page 85.

In the system described in the figure above, communication is usually arranged as shown in the table below.

Data type	REM <-> MicroSCADA	REM, LSG and LONMARK™ a devices to each other
Events and alarms	sliding window protocol	-
Control commands	transparent SPA bus messages	-
Status of breakers and isolators	sliding window protocol	network variables
Analogue measurement values	sliding window protocol	-
Other DI, AI data	sliding window protocol	network variables
Other DO, AO data	transparent SPA bus messages	network variables
Parameter data	transparent SPA bus messages	-
SPA file transfer data (e.g. the disturbance records)	transparent SPA bus messages	-

a. LONMARK is a trademark of Echelon Corporation.

### 4.1.13.6. LON inputs and outputs via a LON bus

The REM 54\_ machine terminal offers up to 32 freely programmable LON inputs and outputs on the LON bus. The inputs and outputs use the LONMARK™ Standard network variable (NV type 83 = SNVT\_state) for sending and receiving process data. The LON inputs and outputs are accessible in the machine terminal configuration and can be freely used for different types of data transfer between REM 54\_ machine terminals and other devices that are able to communicate using the network variable of type SNVT\_state.

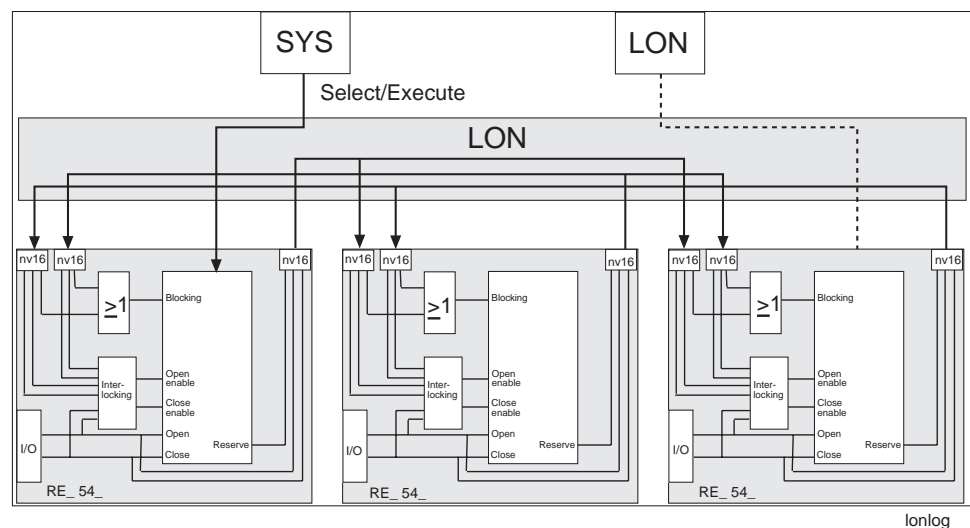

Fig. 4.1.13.6.-1 Principle of connecting LON inputs and outputs to logic functions of the machine terminal

The SNVT\_state can be used to communicate the state of a set of 1 to 16 Boolean values. Each bit indicates the state of the Boolean value with, for example, the following interpretations:

0	1
off	on
inactive	active
disabled	enabled
low	high
false	true
normal	alarm

The value field shows the current value of the digital inputs or outputs at the time of reporting, or the latest value reported from the concerned device.

The SNVT\_state can be used to transfer the state of 1 to 16 digital inputs, or to set the state of 1 to 16 output bits or digital set-points.

#### 4.1.14.

#### Display panel (MMI)

The machine terminal is provided with either a fixed display or an external display module. The external display module requires a separate voltage supply from a common source with the main unit (refer to section “Auxiliary voltage” on page 31). For more information about the rated input voltages, refer to Table 4.2.1.-2 on page 70. A special cable (1MRS120511.001) delivered with the machine terminal is needed for communication between the terminal and the external display panel.

- graphical LCD display, with the resolution 128 x 160 pixels, consisting of 19 rows divided into two windows
- main window (17 rows) providing detailed information on MIMIC, objects, events, measurements, control alarms and parameters of the terminal
- assisting window (2 rows) for terminal-dependent protection indications and alarms, and for general help messages
- three push-buttons for object control
- eight freely programmable alarm LEDs with different colours and modes according to the configuration (off, green, yellow, red, steady, blinking)
- LED indicator for control test and interlocking
- three protection LED indicators
- MMI push-button section with four arrow buttons and buttons for clear [C] and enter [E]
- optically isolated serial communication port
- backlight and contrast control
- freely programmable button [F]
- button for remote/local control (Control position button [R\L])

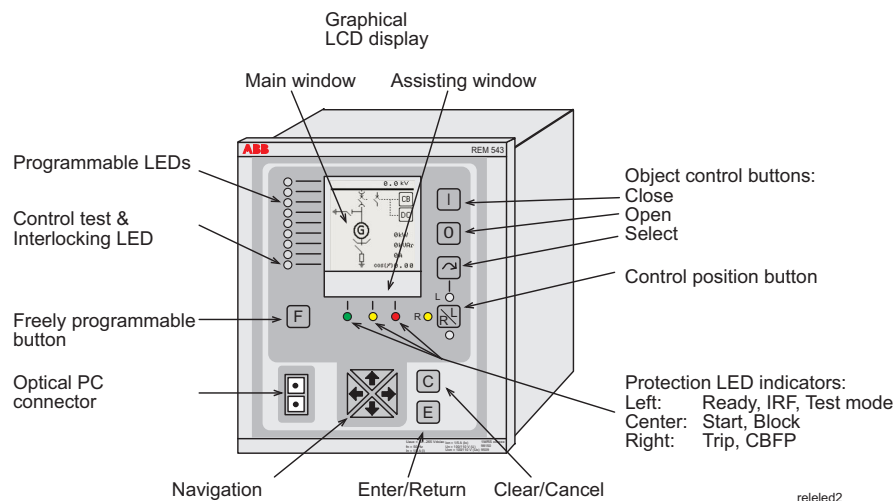

Fig. 4.1.14.-1 Front view of the REM 54\_ machine terminal

The MMI has two main levels, the user level and the technical level. The user level is for “everyday” measurements and monitoring whereas the technical level is intended for advanced machine terminal programming.

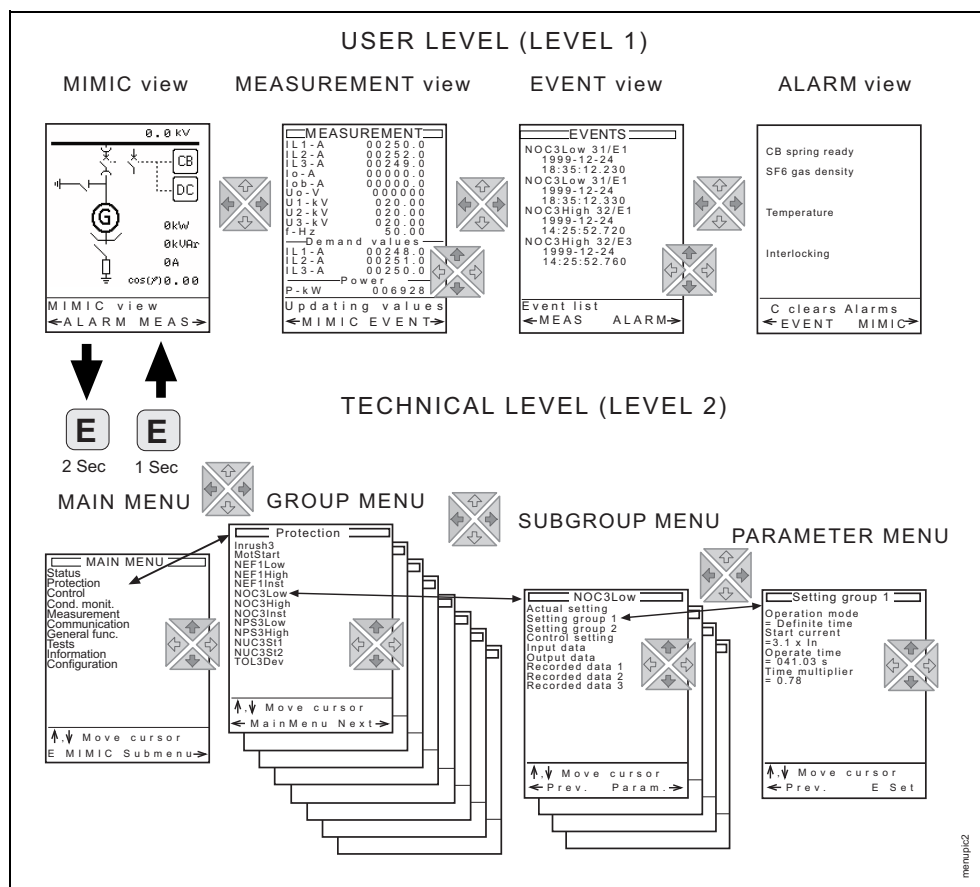

Fig. 4.1.14.-2 Menu level structure

For more detailed information about the MMI, please refer to the Operator’s Manual (1MRS750500-MUM).

**4.1.15.****Alarm LED indicators**

The REM 54\_ machine terminal offers eight alarm LED indicators to be configured with the Relay Mimic Editor. The LED colours are green, yellow or red, and their use can be freely defined (for defining the ON and OFF state texts, refer to section “MIMIC configuration” on page 27). Three basic operation modes are supported:

- non-latched light
- latched-steady light
- latched blinking light

Alarms can be acknowledged remotely, locally or by using logic.

The alarm channels include time tagging for detected alarms. The time tagging principle used depends on the operation mode.

The alarm channels are seen as function blocks in the machine terminal configuration:

Alarm channel	Function block
Alarm channel 1	MMIALARM1
Alarm channel 2	MMIALARM2
Alarm channel 3	MMIALARM3
Alarm channel 4	MMIALARM4
Alarm channel 5	MMIALARM5
Alarm channel 6	MMIALARM6
Alarm channel 7	MMIALARM7
Alarm channel 8	MMIALARM8

**4.1.15.1.****Non-latched alarm**

In a non-latched mode, the ON signal switches between ON and OFF state texts and the corresponding LED colours. Alarm acknowledgement (ACK) clears the last time stamp line of the alarm view, but leaves the corresponding alarm LED state unchanged. An event is generated on the rising and falling edge of the ON signal and by acknowledgement.

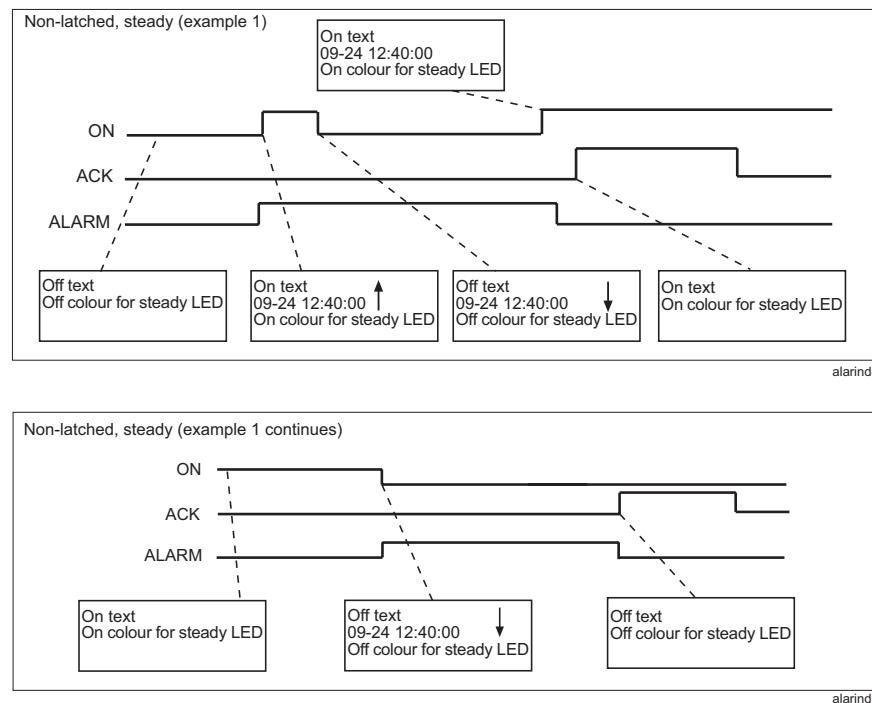

Fig. 4.1.15.1.-1 Example of a non-latched alarm

4.1.15.2.

**Latched alarm, steady LED**

Latched, steady alarms can be acknowledged only when the ON signal is inactive. The time stamp of the first alarm is recorded. Successful acknowledgement clears the time stamp line of the alarm view and the corresponding alarm LED. An event is generated on the rising and falling edge of the ON signal and by acknowledgement.

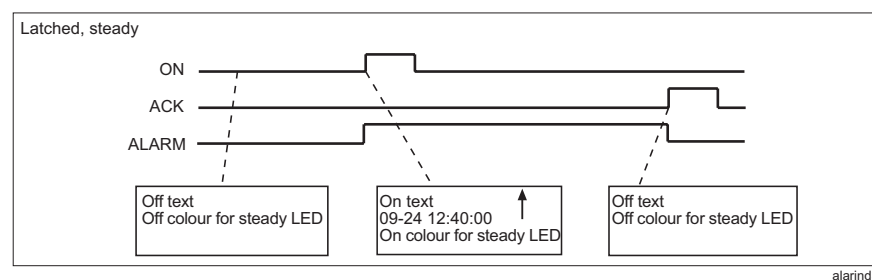

Fig. 4.1.15.2.-1 Example of a latched alarm with steady LED

**4.1.15.3. Latched alarm, blinking LEDs**

Latched, blinking alarms can be acknowledged after the rising edge of the ON signal. The time stamp of the first alarm is recorded. If the ON signal is inactive, acknowledgement clears the time stamp line of the alarm view and the corresponding alarm LED. However, if the ON signal is active during acknowledgement, the alarm LED mode turns stable and the time stamp is cleared. Later, when the ON signal is deactivated, the alarm LED colour will automatically change to OFF colour. An event is generated on the rising and falling edge of the ON signal and by acknowledgement. The visual indication, including resetting, of this alarm mode complies with the ISA-A standard.

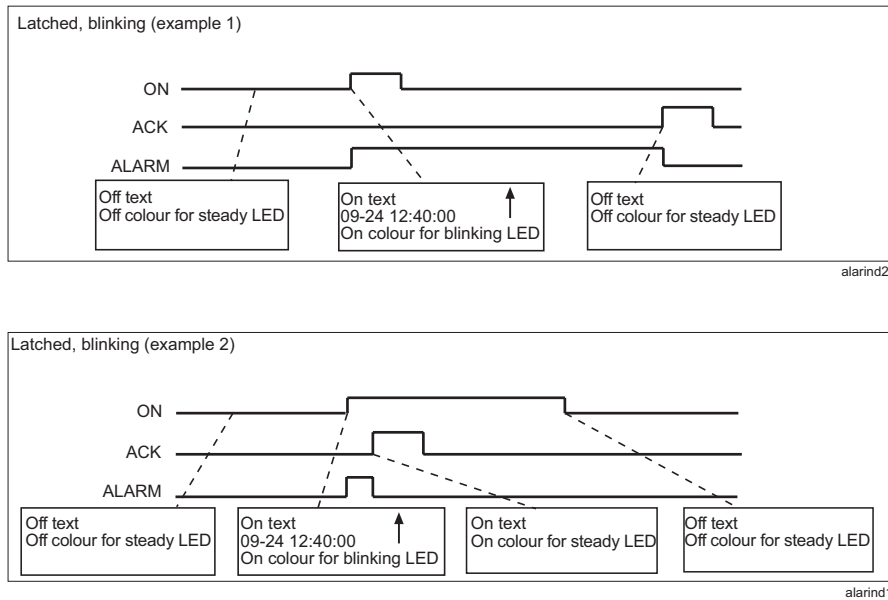

Fig. 4.1.15.3.-1 Example of a latched alarm with blinking LEDs

**4.1.15.4. Interlocking**

The interlocking LED text can be defined in the same manner as for the other alarm channels. The colour of the interlocking LED is yellow and cannot be changed. The normal LED state is inactive (no light). Furthermore, the interlocking LED has two special modes. The first mode, recognized by a steady yellow light, indicates that control operation has been interlocked. The second mode, recognized by a blinking red light, indicates that the interlocking is in bypass mode (control test mode).

**General control test mode**

The system provides a general interlocking bypass mode (Main menu/Control/Interl bypass) that overrides all interlocking signals. Activation of the interlocking bypass mode activates the interlocking enable signals of all control objects. Thus, all local control actions are possible and the enable signals (OPENENA, CLOSEENA) of controllable objects are not checked while the objects are commanded. As long as the mode is active, the interlocking LED on the MMI is blinking red. Additionally, the assisting window of the display will indicate the special condition.

## 4.2. Design description

### 4.2.1. Technical data

**Table 4.2.1.-1 Energizing inputs**

Rated frequency		50.0/60.0 Hz	
Current inputs	rated current	1 A/5 A	
	Thermal withstand capability	continuously	4 A/20 A
		for 1 s	100 A/500 A
	dynamic current withstand, half-wave value	250 A/1250 A	
input impedance	<100mΩ/ <20 mΩ		
Voltage inputs	rated voltage	100 V/110 V/115 V/120 V (parameterization)	
	voltage withstand, continuous	2 x U <sub>n</sub> (240 V)	
	burden at rated voltage	<0.5 VA	
Sensor inputs, max 9	voltage range RMS	9.4 V RMS	
	voltage range peak	±12 V	
	input impedance	>4.7 MΩ	
	input capacitance	<1 nF	

**Table 4.2.1.-2 Auxiliary power supplies**

Type	PS1/240V	External display module	PS1/48V
Input voltage, ac	110/120/220/240 V		-
Input voltage, dc	110/125/220 V		24/48/60 V
Operating range	ac 85...110%, dc 80...120% of rated value		dc 80...120% of rated value
Burden	<50 W		
Ripple in dc auxiliary voltage	max. 12% of the dc value		
Interruption time in auxiliary dc voltage without resetting	<50 ms, 110 V and <100 ms, 200 V		
Internal overtemperature indication	+78°C (+75...+83°C)		

**Table 4.2.1.-3 Digital inputs**

Power supply version	PS1/240 V	PS1/48 V
Input voltage, dc	110/125/220 V	24/48/60/110/125/220 V
Operating range, dc	80...265 V	18...265 V
Current drain	~2...25 mA	
Power consumption/input	<0.8 W	
Pulse counting (specific digital inputs), frequency range	0...100 Hz	

**Table 4.2.1.-4 RTD/analogue inputs**

Supported RTD sensors	100 $\Omega$ Platinum	TCR 0.00385 (DIN 43760)
	250 $\Omega$ Platinum	TCR 0.00385
	1000 $\Omega$ Platinum	TCR 0.00385
	100 $\Omega$ Nickel	TCR 0.00618 (DIN 43760)
	120 $\Omega$ Nickel	TCR 0.00618
	250 $\Omega$ Nickel	TCR 0.00618
	1000 $\Omega$ Nickel	TCR 0.00618
	10 $\Omega$ Copper	TCR 0.00427
Max lead resistance (three-wire measurement)	200 $\Omega$ per lead	
Accuracy	$\pm$ 0.5% of full scale $\pm$ 1.0% of full scale for 10 $\Omega$ Copper RTD	
Isolation	2 kV (inputs to outputs and inputs to protective earth)	
Sampling frequency	5 Hz	
Response time	$\leq$ Filter time + 30 ms (430 ms...5.03 s)	
RTD / Resistance sensing current	max 4.2 mA RMS 6.2 mA RMS for 10 $\Omega$ Copper	
Current input impedance	274 $\Omega$ $\pm$ 0.1%	

**Table 4.2.1.-5 Signal outputs**

Max system voltage	250 V ac/dc
Continuous carry	5 A
Make and carry for 0.5 s	10 A
Make and carry for 3 s	8 A
Breaking capacity when control circuit time-constant L/R <40 ms, at 48/110/220 V dc	1 A/0.25 A/0.15 A

**Table 4.2.1.-6 Power outputs**

Max system voltage	250 V ac/dc	
Continuous carry	5 A	
Make and carry for 0.5 s	30 A	
Make and carry for 3 s	15 A	
Breaking capacity when control circuit time constant L/R <40 ms, at 48/110/220 V dc	5 A/3 A/1 A	
Minimum contact load	100 mA, 24 V ac/dc (2.4 VA)	
TCS (Trip Circuit Supervision)	Control voltage range	20...265 V ac/dc
	Current drain through the supervision circuit	approx. 1.5 mA (0.99...1.72 mA)
	Minimum voltage (threshold) over a contact	20 V ac/dc (15...20 V)

**Table 4.2.1.-7 Analogue outputs**

Output range	0...20 mA
Accuracy	± 0.5% of full scale
Max load	600 Ω
Isolation	2 kV (output to output, output to inputs and output to protective earth)
Response time	≤ 85 ms

**Table 4.2.1.-8 Environmental conditions**

Specified service temperature range	-10...+55°C	
Transport and storage temperature range	-40...+70°C	
Enclosure class	front side, flush-mounted	IP 54
	rear side, connection terminals	IP 20
Dry heat test	according to IEC 60068-2-2	
Dry cold test	according to IEC 60068-2-1	
Damp heat test, cyclic	according to IEC 60068-2-30, r.h. = 95%, T = 25°...55°C	
Storage temperature tests	according to IEC 60068-2-48	

**Table 4.2.1.-9 Standard tests**

Insulation tests	Dielectric test IEC 60255-5	Test voltage	2 kV, 50 Hz, 1 min.
	Impulse voltage test IEC 60255-5	Test voltage	5 kV, unipolar impulses, waveform 1,2/50 μs, source energy 0.5 J
	Insulation resistance measurements IEC 60255-5	Insulation resistance	> 100 MΩ, 500 V dc
Mechanical tests	Vibration tests (sinusoidal)		IEC 60255-21-1, class I
	Shock and bump test		IEC 60255-21-2, class I

**Table 4.2.1.-10 Electromagnetic compatibility tests**

The EMC immunity test level fulfills the requirements listed below		
1 MHz burst disturbance test, class III, IEC 60255-22-1	common mode	2.5 kV
	differential mode	1.0 kV
Electrostatic discharge test, class III IEC 61000-4-2 and 60255-22-2	for contact discharge	6 kV
	for air discharge	8 kV
Radio frequency interference test	conducted, common mode IEC 61000-4-6	10 V (rms), f = 150 kHz...80 MHz
	radiated, amplitude-modulated IEC 61000-4-3	10 V/m (rms), f = 80...1000 MHz
	radiated, pulse-modulated ENV 50204	10 V/m, f = 900 MHz
	radiated, test with a portable transmitter IEC 60255-22-3, method C	f = 77.2 MHz, P = 6 W; f = 172.25 MHz, P = 5 W
Fast transient disturbance test IEC 60255-22-4 and IEC 61000-4-4	power supply	4 kV
	I/O ports	2 kV

**Table 4.2.1.-10 Electromagnetic compatibility tests**

Surge immunity test IEC 61000-4-5	power supply	4 kV, common mode 2 kV, differential mode
	I/O ports	2 kV, common mode 1 kV, differential mode
Power frequency (50 Hz) magnetic field IEC 61000-4-8	100 A/m	
Voltage dips and short interruptions IEC 61000-4-11	30%, 10 ms >90%, 5000 ms	
Electromagnetic emission tests EN 55011 and EN 50081-2	conducted RF emission (mains terminal)	EN 55011, class A
	radiated RF emission	EN 55011, class A
CE approval	Complies with the EMC directive 89/336/EEC and the LV directive 73/23/EEC	

**Table 4.2.1.-11 Data communication**

Rear interface, connector X3.3	RS485 connection	
	LON bus or SPA bus, selectable	
	the fibre-optic interface module RER 103 is needed for galvanic isolation	
	data transfer rates	SPA bus: 4.8/9.6/19.2 kbps, selectable LON bus: 78.0 kbps/1.2 Mbps, selectable
Rear interface, connectors X3.1 and X3.2	not used, reserved for future purposes	
Rear interface, connector X3.4	RJ45 connection	
	galvanically isolated RJ45 connection for an external display panel communication cable	
	1MRS 120511.001	
Front panel	optical RS 232 connection	
	data code	ASCII
	data transfer rates	4.8, 9.6 or 19.2 kbps, selectable
	serial communication cable	1MKC 9500011
Asynchronous serial communication parameters	start bits	1
	data bits	7
	parity	even
	stop bits	1
	baud rate	9.6 kbps (default)
Communication protocols	SPA-bus protocol LON bus	

**Table 4.2.1.-12 General**

Toolboxes	CAP 501 CAP 505 LNT 505	
Event recording	all events are recorded in higher level syntax: reason, time, date the last 100 events are recorded	
Data recording	records operate values	
Protection functions Control functions Condition monitoring functions Measurement functions	see Technical Descriptions of Functions, CD-ROM (1MRS 750889-MCD)	
Self-supervision	RAM circuits ROM circuits Parameter memory circuits CPU watchdog Power supply Digital I/O modules MMI module RTD/analogue input module Internal communication bus A/D converters and analogue multiplexers	
Mechanical dimensions	Width: 223.7 mm (1/2 of a 19" rack) Height, frame: 265.9 mm (6U) Height, box: 249.8 mm Depth: 235 mm For dimension drawings, refer to the Installation Manual (1MRS 750526-MUM)	
	External display module:	Width: 223.7 mm Height: 265.9 mm Depth: 74 mm
Weight of the unit	~8 kg	

4.2.2. Terminal diagram of REM 543

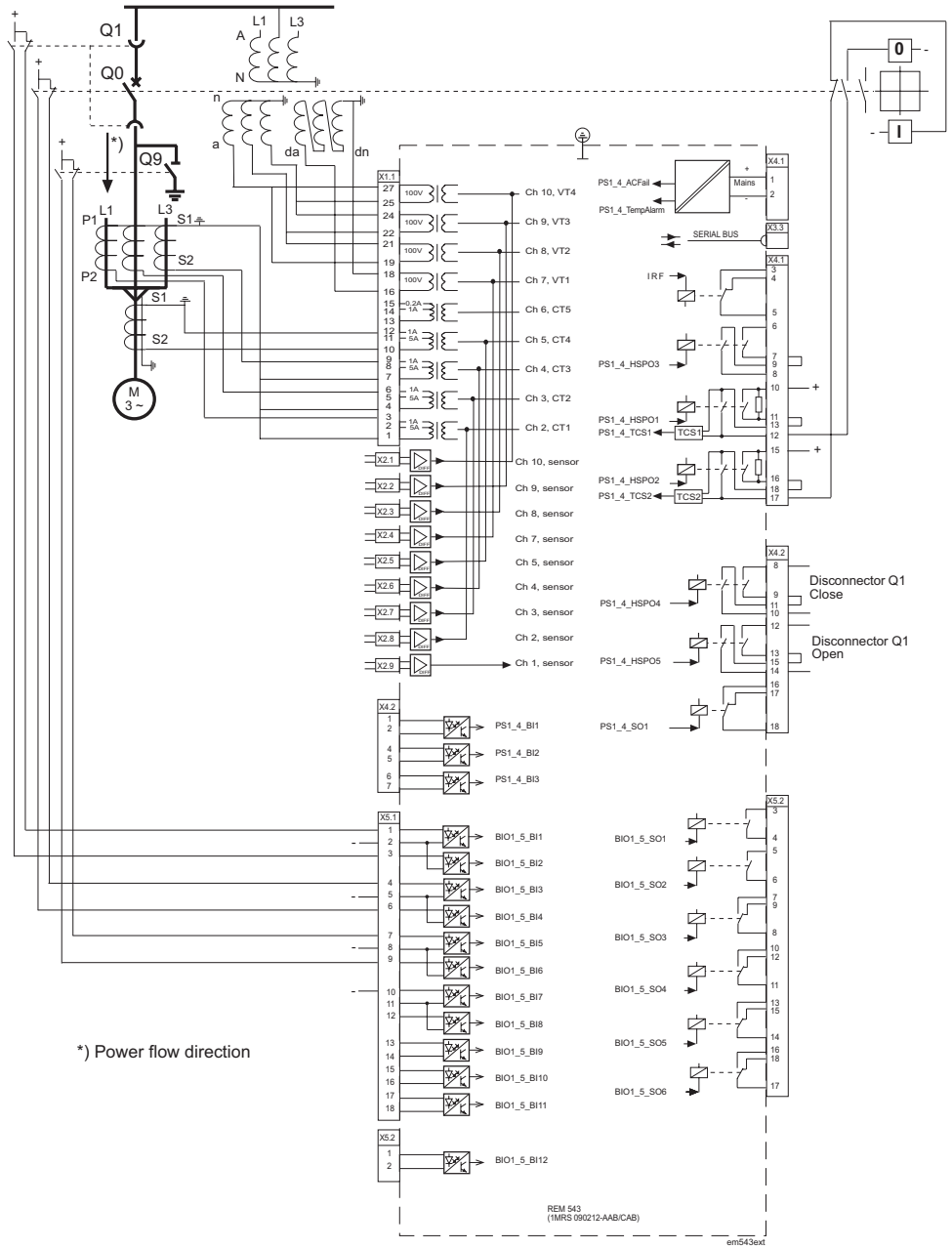

4.2.3. Terminal diagram of REM 545

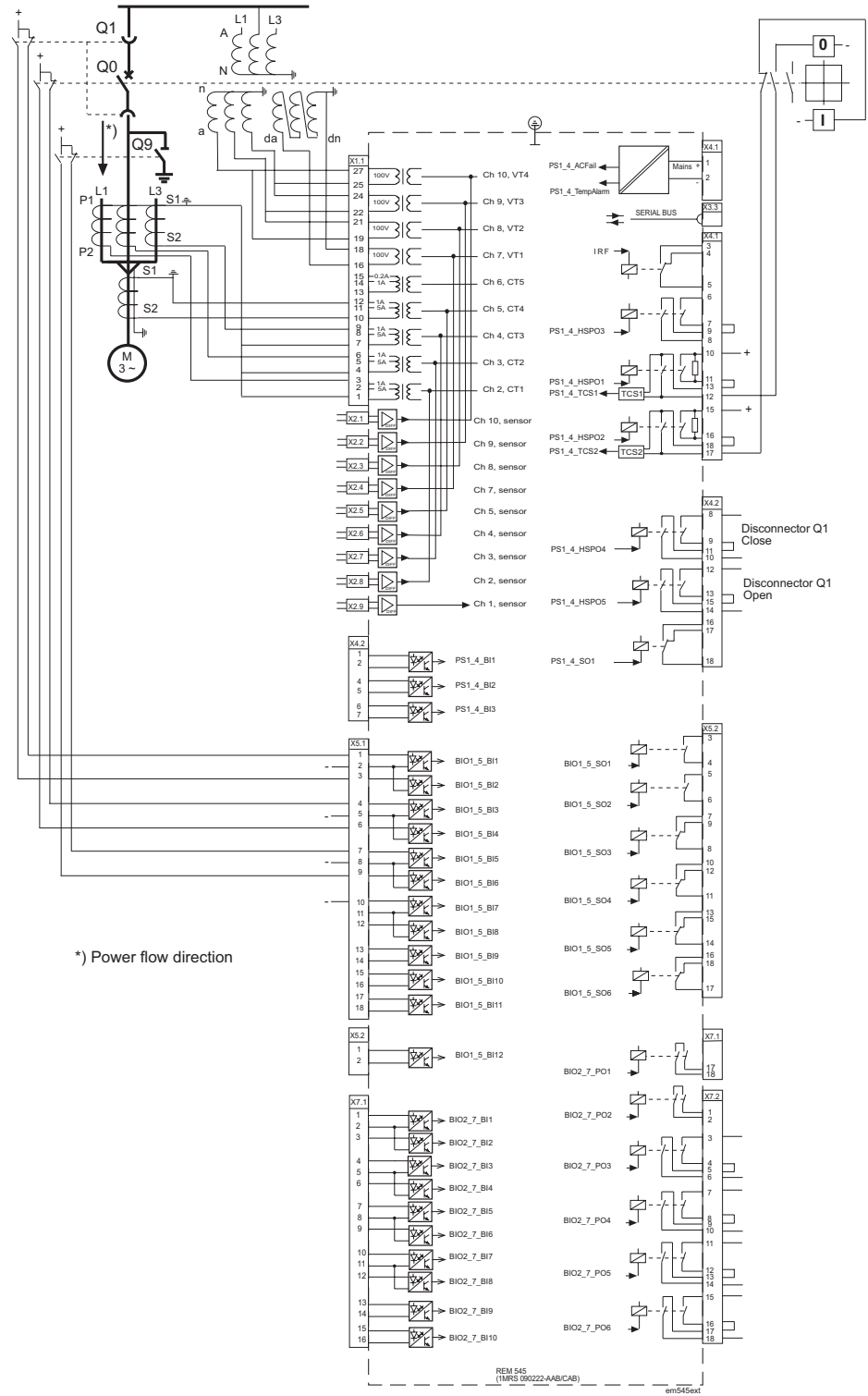

\*) Power flow direction

REM 545 (1MRS 090222-4ABCAB) en545ext

### 4.2.4. Terminal diagram of the RTD/analogue module

Terminal diagrams for the REM 543 and REM 545 machine terminals provided with an RTD/analogue module are similar to the diagrams presented in sections “Terminal diagram of REM 543” on page 75 and “Terminal diagram of REM 545” on page 76, except for the part illustrating the RTD/analogue module (see below), which is added to the diagrams considering the slot numbers.

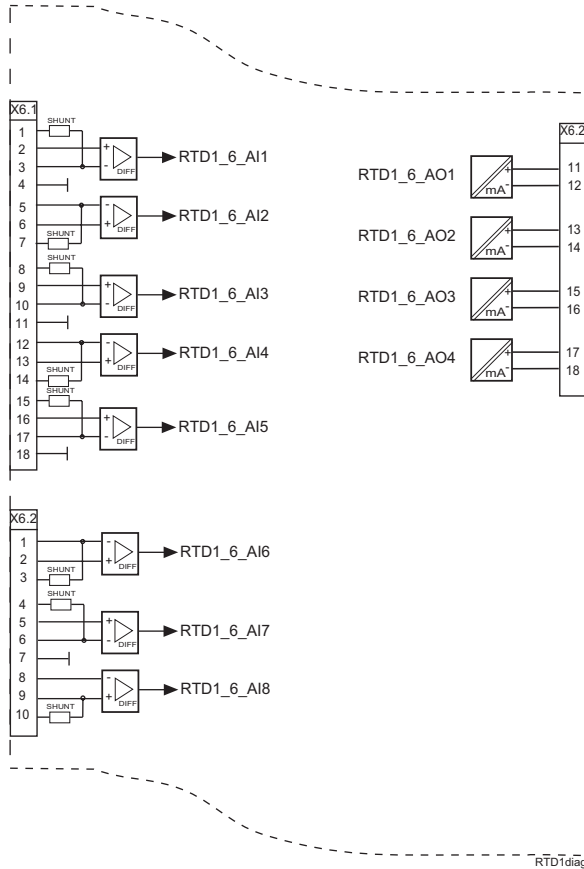

#### 4.2.5. Definition of power direction

When the overexcited generator (G) feeds the inductive load (motor M), the real and reactive power signs are as shown in the figure below. The connections in relay A and relay B are identical (e.g. as in the terminal diagram of REM543 on page 75) and the power direction parameter (e.g. in function blocks UPOW\_, OPOW\_, MEPE7) in both relays is set to “forward”.

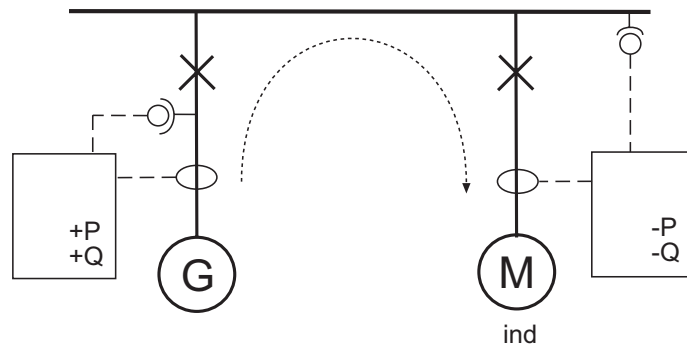

Fig. 4.2.5.-1 Definition of power direction in REM 54\_

#### 4.2.6. Terminal connections

All external circuits are connected to the terminal blocks on the rear panel. Terminal block X1.1 for the measuring transformers consists of fixed screw terminals fastened to the energizing input module. Each terminal is dimensioned for one max. 6 mm<sup>2</sup> or two max. 2.5 mm<sup>2</sup> wires.

ABB sensors (Rogowski coil or voltage divider) are connected to the connectors X2.1...X2.9. A special type of shielded twin BNC connector (e.g. type AMP 332225 or Amphenol 31-224) is used to improve reliability and protection against disturbances. The current and/or voltage sensor used must have a connector that is compatible with the machine terminal. If the machine terminal is ordered without sensor inputs, the sensor connectors X2.1...X2.9 are missing. Short-circuit connectors (1MRS120515) must be connected to unused sensor inputs.

The serial interface RS-485 on the rear panel (connector X3.3) is used for connecting the machine terminal to the SPA bus or the LON bus. The SPA/LON bus is connected via the connection module type RER 103 fitted to the 9-pin D-type subminiature connector and screwed to the rear panel.

The connectors X4.1...X7.2 are 18-pin detachable multi-pole connector strips with screw terminals. The male part of the multi-pole connector strips is fastened to the printed circuit boards. The female parts, including accessories, are delivered together with the machine terminal. The female connector part can be secured with fixing accessories and screws. One max. 1.5 mm<sup>2</sup> wire or two max. 0.75 mm<sup>2</sup> wires can be connected to one screw terminal.

The digital inputs and outputs (contacts) of the machine terminal are connected to the multi-pole connectors X4.1...X7.2. The auxiliary power supply is connected to the terminals X4.1:1 (plus polarity) and X4.1:2 (minus polarity). When the RTD/

## Technical Reference Manual

analogue module is used, the inputs and outputs are connected to the terminals X6.1:1 and X6.1:2. The machine terminal self-supervision output IRF is linked to the terminals X4.1:3, X4.1:4 and X4.1:5.

Protective earth is connected to the screw marked with the earth symbol.

The connectors are designated according to the module slot in the REM 54\_ machine terminal.

Connector	Description
X1.1	connector for transformer inputs (current and voltage transformers) (module slot 1)
X2.1	connector for sensor input 8 (slot 2)
X2.2	connector for sensor input 7 (slot 2)
X2.3	connector for sensor input 6 (slot 2)
X2.4	connector for sensor input 5 (slot 2)
X2.5	connector for sensor input 4 (slot 2)
X2.6	connector for sensor input 3 (slot 2)
X2.7	connector for sensor input 2 (slot 2)
X2.8	connector for sensor input 1 (slot 2)
X3.1	not used, reserved for future purposes (slot 3)
X3.2	not used, reserved for future purposes (slot 3)
X3.3	connector for RS-485 interface (slot 3)
X3.4	connector for the external display module (slot 2)
X4.1	upper connector for combined I/O and power supply module PS1 (slot 4)
X4.2	lower connector for combined I/O and power supply module PS1 (slot 4)
X5.1	upper connector for I/O module BIO1 (slot 5)
X5.2	lower connector for I/O module BIO1 (slot 5)
X6.1	upper connector for I/O module BIO1 (slot 6), REM 543 upper connector for RTD/analogue module (slot 6), REM 543 or REM 545 with RTD/analogue module
X6.2	lower connector for I/O module BIO1 (slot 6), REM 543 lower connector for RTD/analogue module (slot 6), REM 543 or REM 545 with RTD/analogue module
X7.1	upper connector for I/O module BIO2 (slot 7)
X7.2	lower connector for I/O module BIO2 (slot 7)

REM543B\_212AABA/CABA

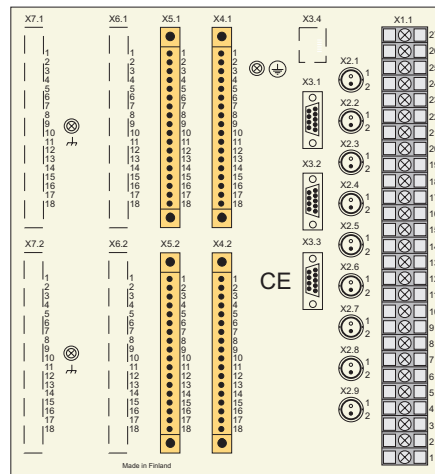

BIO1  
PS1  
CPU1  
MIM, SIM,  
Transfr

REM543A\_213AABA/CABA

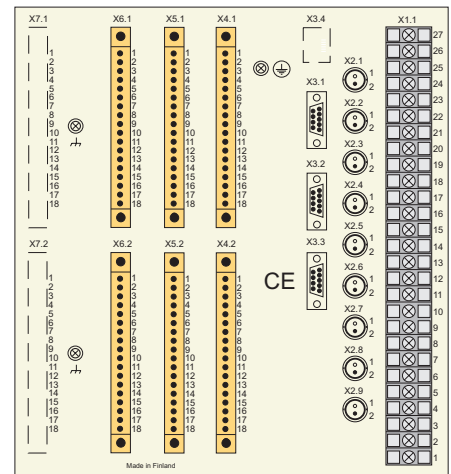

RTD1  
BIO1  
PS1  
CPU1  
MIM, SIM,  
Transfr

REM543Rs

Fig. 4.2.6.-1 Rear views of REM 543 (right: with RTD/analogue module)

REM545A\_222AABA/CABA

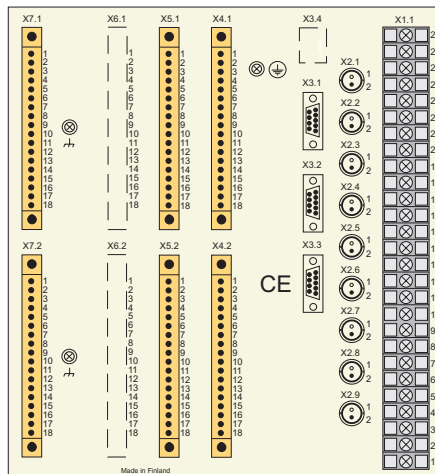

BIO2  
BIO1  
PS1  
CPU1  
MIM, SIM,  
Transfr

REM545A\_223AABA/CABA

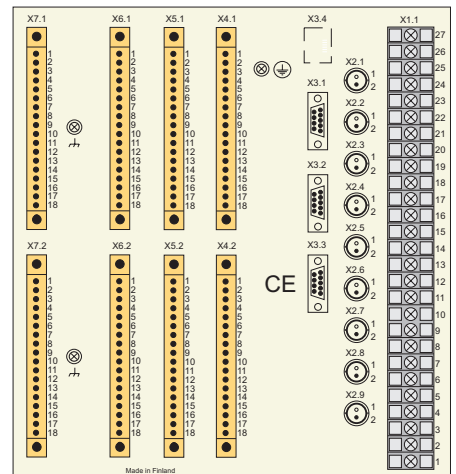

BIO2  
RTD1  
BIO1  
PS1  
CPU1  
MIM, SIM,  
Transfr

REM545Rs

Fig. 4.2.6.-2 Rear views of REM 545 (right: with RTD/analogue module)

REM545A\_223AABB

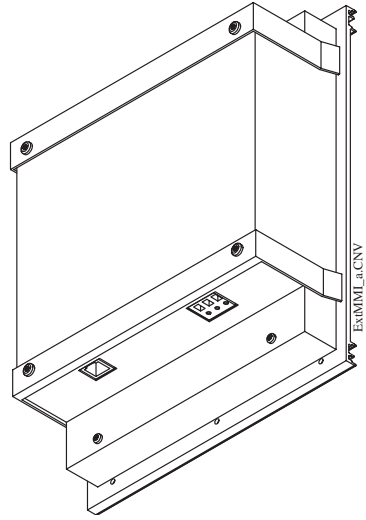
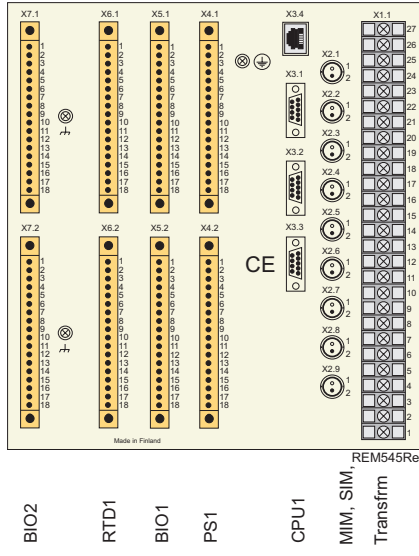

Fig. 4.2.6.-3 Rear view of REM 545 with an external display module (right: the external display module)

## 5. Service

When the machine terminal is used under the conditions specified in section “Technical data”, it is practically maintenance-free. The machine terminal electronics include no parts or components subject to abnormal physical or electrical wear under normal operating conditions.

If the terminal fails in operation or if the operating values considerably differ from those mentioned in the machine terminal specifications, the terminal should be overhauled. Minor measures can be taken by the personnel in the customer’s instrument work-shop, but all major repairs involving the electronics are to be taken by the manufacturer. Please contact the manufacturer or his nearest representative for further information about checking, overhaul and recalibration of the terminal.



To achieve the best possible operation accuracy, all parts of a REM 54\_ product have been calibrated together. Thus, each product forms a whole for which no separate spare parts can be supplied. In the event of malfunction, please consult your relay supplier.

If the machine terminal is required to be sent back to the manufacturer due to maloperation, it is essential that the Customer Feedback form, including especially the Service Report part, is carefully filled in and enclosed with the terminal.



The machine terminal to be sent to the manufacturer has to be carefully packed to prevent further damage to the device.

## 6. Ordering Information

### 6.1. Order number

The following is to be specified when ordering REM 54\_ machine terminals:

- Order number (see Figure 6.1.-1 below)
- Display language combination (e.g. English-German)
- Quantity of machine terminals

Each REM 54\_ machine terminal has a specific order number that identifies the machine terminal type as well as the hardware and the software as described in Figure 6.1.-1 below. The order number is labelled on the marking strip on the front panel of the machine terminal delivered, e.g. Order No: REM543BM212AAAA.

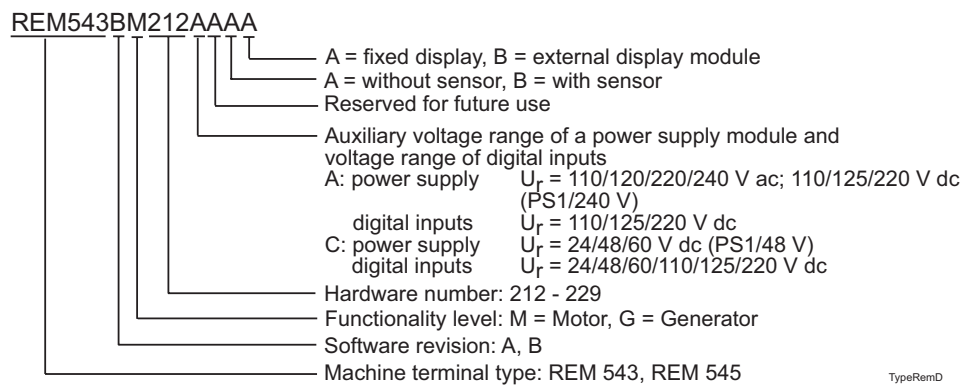

Fig. 6.1.-1 Order number of REM 54\_

The functionality level determines the selection of function blocks available for the machine terminal. For more detailed information on the separate function blocks included in each selection, please consult your relay supplier.

Functionality level	Application area
M	Motor protection
G	Generator protection

The display language combination (see table below) is identified by a three-digit suffix in the software number labelled on the front panel of the machine terminal, e.g. Software No: 1MRS110019-001.

Suffix	Language combination
001	English - German
002	English - Swedish
003	English - Finnish

The REM 543 and REM 545 machine terminals differ from each other as to the number of digital inputs and outputs as follows:

Number of inputs/outputs	REM 543	REM 545
Digital inputs	15	25
Trip circuit supervision inputs	2	2
Power outputs (NO single-pole)	-	2
Power outputs (NO double-pole)	5	9
Signal outputs (NO)	2	2
Signal outputs (NO/NC)	5	5
Self-supervision outputs	1	1

## 6.2. Hardware versions of REM 543 and REM 545

For the number of digital inputs and outputs of REM 54\_ machine terminals, refer to section “Order number” above. The number of matching transformers, sensor inputs and analogue inputs and outputs, and the auxiliary voltage range vary between the different hardware versions of REM 54\_. Moreover, both REM 543 and REM 545 can be supplied with an RTD/analogue module. For more detailed information about the hardware of REM 54\_, refer to section “Hardware versions” on page 7.

## 6.3. Software configuration

Each REM 54\_ machine terminal allows different software configurations based on separate functions (refer to section “Functions of the machine terminal” on page 20). Functions included in the selected functionality level (refer to section “Ordering Information” on page 83) can be activated within the scope of the I/O connections and considering the total CPU load of the functions.

## 7. Revision History of REM 54\_

### 7.1. Revision identification

The main releases of the REM 54\_ products are differentiated with the software revision letter in the order number of the machine terminal and the corresponding software number, both of which are printed on the marking strip on the front panel of the machine terminal, for example as follows:

Order No: REM543BM212AAAA

Software No: 1MRS110019-001

**Table 7.1.-1 Revisions of REM 54\_**

Product	Revision	Software No	Release
REM 543	A	1MRS110010-001	Release 1.5 (Dec 1998)
	B	1MRS110018-00_	Release 2.0 (May 2000)
REM 543 (RTD1)	A	1MRS110019-00_	Release 2.0 (May 2000)
REM 545	A	1MRS110020-00_	Release 2.0 (May 2000)
REM 545 (RTD1)	A	1MRS110021-00_	Release 2.0 (May 2000)

The revision letter determines the main release which may involve functional additions and changes to the product. The changes included in each revision compared to the previous one are described in more detail below.

### 7.2. Release 2.0

#### 7.2.1. Changes and additions to earlier released revisions

##### General

- Additional scaling factor for setting the displacement error of current and voltage sensors. For further information refer to section “Technical data of the measuring devices” on page 36.
- Number of sensor types increased from 3 to 10 (each sensor channel can be set separately)
- New measuring device and signal GE1...3 to be used with the MEAI1...8 function blocks. For further information refer to the CD-ROM “Technical Descriptions of Functions” (1MRS750889-MCD).
- Amount of measuring signal types for current and voltage increased
  - IL1b, IL2b, IL3b
  - U12b, U23b, U31b, U1b, U2b, U3b
  - Uob
- Improved storing, shorter storing time

- New language versions:
  - English - Swedish
  - English - Finnish
- An informative parameter, “Config. capacity”, added (Main menu/ Configuration/General/Config. capacity). For further information refer to the Configuration Guideline (1MRS 750745-MUM).
- Menu descriptions of virtual I/Os changed to match the names in tools
- 48-hour capacitor back-up for the internal clock of the machine terminal
- Selection of latching feature for the Start LED can be stored in the non-volatile memory

### Function blocks

- Function block revision added (uploading of the function block list to CAP 505)
- Measurement function blocks: outputs indicating the status of warning and alarm limits added
- Under- and overvoltage protection function blocks UV3\_ and OV3\_:
  - phase-selective start outputs added
  - control setting parameter “Oper. hysteresis” added for adjusting the level of a comparator (for more information, refer to the CD-ROM “Technical Descriptions of Functions”)
- EVENT230 function block: input interface changed
- Changes to input names in the following function blocks: UV3Low, UV3High, OV3Low, OV3High, MEVO3A, CMVO3
- MEPE7, the function block for power and energy measurement:
  - Events for energy (E), apparent power (S), and  $\cos \phi$  added
  - Time-based delta event sending added
- Start time range of the MotStart function block changed from 0.3...80.0 s to 0.3... 250 s

For further information about the above changes, refer to the function block descriptions on the CD-ROM 1MRS 750889-MCD.

### New protection functions

Function	Description
Diff3	High-impedance or flux-balance based differential protection for generators and motors
FuseFail	Fuse failure supervision
PREV3	Phase reversal protection
PSV3St1	Phase-sequence voltage protection, stage 1
PSV3St2	Phase-sequence voltage protection, stage 2
UI6Low	Three-phase underimpedance protection, low-set stage
UI6High	Three-phase underimpedance protection, high-set stage
OE1Low	Overexcitation protection, low-set stage
OE1High	Overexcitation protection, high-set stage

**New measurement functions**

Function	Description
MEAI1	General measurement 1 / analogue input on RTD/analogue module
MEAI2	General measurement 2 / analogue input on RTD/analogue module
...	
MEAI8	General measurement 3 / analogue input on RTD/analogue module
MEAO1	Analogue output 1 on RTD/analogue module
MEAO2	Analogue output 2 on RTD/analogue module
MEAO3	Analogue output 3 on RTD/analogue module
MEAO4	Analogue output 4 on RTD/analogue module

**New condition monitoring functions:**

Function	Description
CMGAS3	Three-pole gas density monitoring

**Protocols & communication**

- Uploading/downloading of the Relay Configuration Tool project (RCT) from/to the machine terminal for the Relay Configuration Tool
- Parallel communication support: simultaneous use of the front and rear connectors was not allowed earlier

**Hardware & mechanics**

- New mechanics
- External display module
- New CPU module with a communication port for an external display module
- New hardware versions with an RTD/analogue module
- One sensor channel added (total of 9 channels)
- Voltage threshold for digital inputs:
  - power supply 110/120/220/240 V ac or 110/125/220 V dc with the digital input voltage range 110/125/220 V dc
  - power supply 24/48/60 V dc with the digital input voltage range 24/48/60/110/125/220 V dc

**Tools**

- Uploading/downloading of the Relay Configuration Tool project (RCT in CAP 505) from/to the machine terminal via SPA or LON
- Uploading/downloading of settings (CAP501/CAP505) from/to the machine terminal via the rear serial port RS-485 of REM 54\_ using LON
- Uploading of disturbance recordings to MicroSCADA and CAP 505 via SPA or LON

**7.2.2.****Configuration, setting and SA system tools**

The following tool versions are needed to support the new functions and features of Release 2.0 revisions of REM 54\_:

- CAP 505 Relay Product Engineering Tools; CAP 505 v. 2.0.0
- CAP 501 Relay Setting Tools; CAP 501 v. 2.0.0
- LNT 505 LON Network Tool; LNT 505 v. 1.1.1
- LIB 510 Library for MicroSCADA v. 8.4.3; LIB 510 v. 4.0.3

## 8. References

### Manuals for REM 54\_

- Installation Manual <sup>1)</sup> 1MRS750526-MUM
- Operator's Manual <sup>1)</sup> 1MRS750500-MUM
- Technical Reference Manual, General <sup>1)</sup> 1MRS750915-MUM
- Configuration Guideline <sup>1)</sup> 1MRS750745-MUM
- Technical Descriptions of Functions (CD-ROM) 1MRS750889-MCD

### Parameter and event lists for REM 54\_

- Parameter List for REM 543 and REM 545 <sup>1)</sup> 1MRS751784-MTI
- Event List for REM 543 and REM 545 <sup>1)</sup> 1MRS751785-MTI

### Manual for the fibre-optic interface module

- Technical Description of the RER 103 <sup>1)</sup> 1MRS750532-MUM

### Tool-specific manuals

- CAP505 Installation and Commissioning Manual <sup>2)</sup> 1MRS751273-MEN
- CAP505 Operator's Manual <sup>2)</sup> 1MRS751709-MUM
- CAP501 Installation and Commissioning Manual <sup>3)</sup> 1MRS751270-MEN
- CAP501 Operator's Manual <sup>3)</sup> 1MRS751271-MUM
- Relay Configuration Tool, Quick Start Reference <sup>2)</sup> 1MRS751275-MEN
- Relay Configuration Tool, Tutorial <sup>2)</sup> 1MRS751272-MEN
- Relay Mimic Editor, Configuration Manual <sup>2)</sup> 1MRS751274-MEN
- SM/RED Configuration Manual <sup>4)</sup> 1MRS751392-MEN
- RED Relay Tool, Operator's Manual <sup>4)</sup> 1MRS751383-MUM
- DR Collector Tool, Operator's Manual <sup>4)</sup> 1MRS751387-MUM
- LNT 505 Installation and Commissioning Manual 1MRS751705-MUM
- LNT 505 Operator's Manual 1MRS751706-MUM

<sup>1)</sup> Included on the CD-ROM "Technical Descriptions of Functions", 1MRS750889-MCD

<sup>2)</sup> Included on the CD-ROM "Relay Product Engineering Tools", 1MRS751788-MCD

<sup>3)</sup> Included on the CD-ROM "Relay Setting Tools", 1MRS751787-MCD

<sup>4)</sup> Included on the CD-ROMs 1MRS751788-MCD and 1MRS751787-MCD

---

## 9. Glossary

AI	analogue input
CB	circuit breaker
CBFP	circuit-breaker failure protection
CPU	central processing unit
CT	current transformer
DI	digital input
DO	digital output
EMC	electro-magnetic compatibility
GND	ground
HSPO	high-speed power output
I/O	input/output
IRF	internal relay fault
LCD	liquid-crystal display
LED	light-emitting diode
LON <sup>®</sup>	Local Operating Network <sup>1</sup>
LONMARK <sup>™</sup>	LONMARK interoperability association is an independent world-wide industry association, which facilitates the development and implementation of open, interoperable LonWorks based control products and systems. <sup>1</sup>
LONWORKS <sup>®</sup>	technology for intelligent distributed control
L/R	local/remote
LV	low voltage
MIMIC	a graphic configuration picture on the LCD of a relay
MMI	man-machine interface
MV	medium voltage
NO/NC	normally open/ normally closed
PCB	printed circuit board
PLC	programmable logic controller
PO	power output
PS	power supply
RTD	resistance temperature device
SNVT	standard network variable type
SO	signal output
SPA	data communication protocol developed by ABB
SPACOM	ABB product family

1) LON and LONWORKS are trademarks of Echelon Corporation registered in the United States and other countries. LONMARK is a trademark of Echelon Corporation.

**10.****Index**

<b>A</b>	
Alarm indication .....	67
Alarm modes .....	27
Alarm texts .....	27
Analogue channels .....	32
Analogue interface .....	8, 9, 10, 11, 12, 13, 14, 15
Analogue outputs .....	8, 9, 10, 11, 12, 13, 14, 15, 57, 72
Application .....	17
Attributes of a digital input .....	43
Auxiliary power .....	31, 32, 70
<b>C</b>	
Calculated analogue channels .....	39
Communication .....	17, 24, 62, 73
Condition monitoring functions .....	23
Configuration .....	19, 26
Connections .....	78
Connectors .....	78
Control functions .....	22
CPU load .....	17, 84
CPU module .....	7, 8, 9, 10, 11, 12, 13, 14, 15, 87, 90, 96
Current measurement .....	20
Current sensor .....	8, 9, 10, 11, 12, 13, 14, 15, 33, 37
Current transformer .....	8, 9, 10, 11, 12, 13, 14, 15, 20, 37
Customer Feedback .....	95
<b>D</b>	
Digital inputs .....	8, 9, 10, 11, 12, 13, 14, 15, 39, 70
Digital outputs .....	8, 9, 10, 11, 12, 13, 14, 15, 44
Dimensions .....	74
Double-pole power output .....	8, 9, 10, 11, 12, 13, 14, 15, 47
Downloading the configuration .....	26
<b>E</b>	
Electromagnetic compatibility .....	72
Energizing inputs .....	70
Environmental conditions .....	18, 72
Event recording .....	74
External display module .....	8, 9, 10, 11, 12, 13, 14, 15, 79
<b>F</b>	
Fault codes .....	61
Fault indication .....	61
Feedback .....	95
Filter time of a digital input .....	41
Functionality .....	17
Functions .....	18, 20
<b>H</b>	
Hardware .....	7, 35, 84
High-speed double-pole power output (HSPO) .....	45

---

I	
Interlocking LED .....	28, 69
Inversion of a digital input .....	41
IRF .....	61
IRF output .....	8, 9, 10, 11, 12, 13, 14, 15, 61
L	
Latched alarm .....	68
LED .....	27, 67
Logic functions .....	24
LON bus .....	62
LON network configuration .....	19, 29
LON Network Tool .....	29
M	
Manuals .....	89
Matching transformer .....	32
Measurement functions .....	17, 21
Measuring devices .....	36
Mechanical dimensions .....	74
MIMIC picture .....	27
MMI .....	8, 9, 10, 11, 12, 13, 14, 15, 17, 30, 65
N	
Non-latched alarm .....	67
O	
Order number .....	8, 9, 10, 11, 12, 13, 14, 15, 33, 83
Ordering .....	83
Oscillation suppression .....	43
Overtemperature indication .....	32
P	
Parameterization .....	29
Parameters .....	29, 30
PC connection .....	62
PLC functions .....	17, 26
Power direction .....	78
Power output (PO) .....	8, 9, 10, 11, 12, 13, 14, 15, 44, 71
Power supply .....	8, 9, 10, 11, 12, 13, 14, 15, 31, 70
Protection functions .....	17, 20
Pulse counters .....	42
R	
Rated frequency .....	29, 70
Rated values .....	36
References .....	89
Relay Configuration Tool .....	19, 26, 35
Relay Mimic Editor .....	19, 27
Relay Setting Tool .....	30
Revisions of REM 54_ .....	85
Rogowski coil .....	20, 33, 37
RTD/analogue inputs .....	8, 9, 10, 11, 12, 13, 14, 15, 48, 71
RTD/analogue module .....	8, 9, 10, 11, 12, 13, 14, 15
S	
Scaling factors .....	36

---

Self-supervision (IRF) .....	61
Sensor channels .....	8, 9, 10, 11, 12, 13, 14, 15
Serial communication .....	62
Service .....	82
Service report .....	96
Signal output (SO) .....	8, 9, 10, 11, 12, 13, 14, 15, 48, 71
Single-pole power output .....	8, 9, 10, 11, 12, 13, 14, 15, 46
Software .....	84
SPA bus .....	62
Standard functions .....	24
Storing of parameters .....	30
<b>T</b>	
Technical data .....	70
Temperature supervision .....	32
Terminal connections .....	78
Terminal diagrams .....	75
Tests .....	72
Threshold voltage .....	8, 9, 10, 11, 12, 13, 14, 15
Transformers .....	8, 9, 10, 11, 12, 13, 14, 15
Trip circuit supervision .....	8, 9, 10, 11, 12, 13, 14, 15, 59
<b>V</b>	
Virtual channel .....	39
Voltage divider .....	20, 33, 37
Voltage measurement .....	20
Voltage transformer .....	8, 9, 10, 11, 12, 13, 14, 15, 20, 37



---

# 11. Customer Feedback

Date: \_\_\_\_\_ To fax: +358 10 224 1094

Category:                    \_\_Comment            \_\_Query            \_\_Complaint

In case of feedback related to a specific product, please name the product.

Product: \_\_\_\_\_

Description: \_\_\_\_\_  
\_\_\_\_\_  
\_\_\_\_\_  
\_\_\_\_\_

Initiator: \_\_\_\_\_

Issuer: \_\_\_\_\_

Company: \_\_\_\_\_

Country: \_\_\_\_\_

Telefax no/  
e-mail address: \_\_\_\_\_



If the machine terminal is required to be sent back to the manufacturer, also fill in the Service Report form (overleaf).

**Service Report for REM 54\_**

Name of the station/project \_\_\_\_\_

(Fill in this form. Use one form per terminal.)

Date & Time \_\_\_\_\_

**Relay information (from the MMI menu)**

**MAIN MENU/Status/General.**

IRF code \_\_\_\_\_

(Before reset)

(After reset)

Status \_\_\_\_\_

**MAIN MENU/Information/ Identification.**

Hardware No \_\_\_\_\_

Software No \_\_\_\_\_

Serial No \_\_\_\_\_

Final test date \_\_\_\_\_

**MAIN MENU/Information/ CPU1.**

SW build \_\_\_\_\_

SW revision \_\_\_\_\_

SW version \_\_\_\_\_

Serial No \_\_\_\_\_

**MAIN MENU/Configuration/ General.**

Config counter \_\_\_\_\_

**Configuration**

Made by \_\_\_\_\_

Company \_\_\_\_\_

Reference (Filename, version number, etc.) \_\_\_\_\_

Configuration date (Downloaded to the relay) \_\_\_\_\_

**Environment**

MicroSCADA version \_\_\_\_\_

Protocol (SPA, LON,...) \_\_\_\_\_

Bay No. or place \_\_\_\_\_

Aux. voltage (power sup.) \_\_\_\_\_

Digital I/O aux. voltage \_\_\_\_\_

Version of relay tools

CAP 501 \_\_\_\_\_

CAP 505 \_\_\_\_\_

LNT 505 \_\_\_\_\_

LIB 510 \_\_\_\_\_

**Contact information**

Handled by \_\_\_\_\_

Company \_\_\_\_\_



**Read the information before reset and pay attention to whether the IRF code changes after reset.**









**ABB Substation Automation Oy**  
P.O. Box 699  
FIN-65101 VAASA  
Finland  
Tel. +358 10 224 000  
Fax. +358 10 224 1094  
[www.abb.com/substationautomation](http://www.abb.com/substationautomation)