

# CDPI-01/-02 panel bus adapters

## User's manual

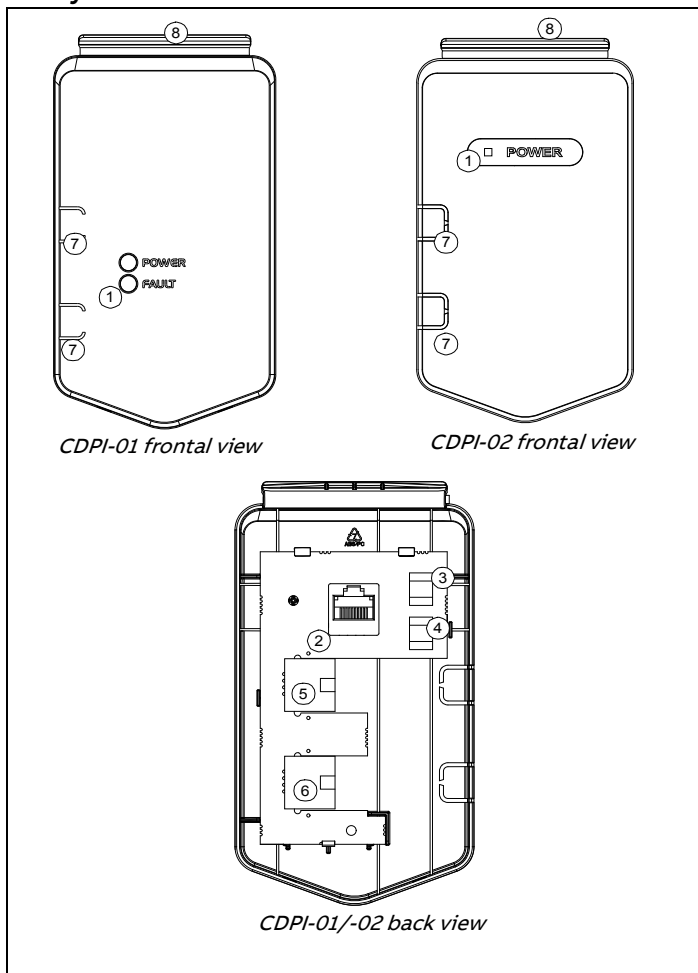

### Layout



Item	Description
1	LEDs mirrored from the drive control unit
2	Connector X100 to the drive control unit
3	Termination switch (S100)
4	Bias switch (S101)
5	Connector X101 for connecting a control panel or a PC
6	Connector X102 for chaining a panel bus
7	Cable hole locations. Used when the cabling connected to the adapter is routed outside the drive.
8	Clip for attaching the module to the drive

## 1. Introduction to the manual

### Safety instructions

**WARNING!** Obey the safety instructions for the drive. If you ignore the safety instructions, injury or death can occur.

### Target audience

This manual is intended for people who plan to install, start up, use and service the CDPI-01/-02 panel bus adapters. Before you do work on the adapters, read this manual and the applicable drive manual that contains the hardware and safety instructions for the product in question.

You are expected to know the fundamentals of electricity, wiring, electrical components and electrical schematic symbols.

The manual is written for readers worldwide. Both SI and imperial units are shown.

## 2. Product overview

The CDPI-01/-02 panel bus adapters can be used to connect a remote control panel to the drive, or to chain the control panel or a PC to several drives on a panel bus.

The panel bus can have a maximum of 32 nodes. The control panel/PC is the master, while the drives equipped with the panel bus adapter are followers.

The CDPI-01/-02 panel bus adapter supports following control panels:

- ACS-AP-S
- ACS-AP-I
- ACS-AP-W
- ACS-BP-S
- ACH-AP-H
- ACH-AP-W

### Applicability

This manual applies to ACS580, ACH580, ACQ580, ACS480 and ACH480 drives. The table below shows types of panel bus adapter applicable for each drive type.

Drive type	Panel bus adapter
ACS580-01	CDPI-01
ACH580-01	CDPI-01
ACH580-31	CDPI-01
ACQ580-01	CDPI-01
ACQ580-31	CDPI-01
ACS480-04	CDPI-02
ACH480-04	CDPI-02

## 3. Planning the installation

The cabling to the panel bus adapter can be routed outside the drive.

In ACS580, ACH580, and ACQ580 drives, you can also route the cables inside the drive through the drive bottom plate.

### Necessary tools and instructions

Cutter/knife to cut holes for cables in the panel bus adapter plastic wall.

In ACS580, ACH580, and ACQ580 drives, on installing the panel bus adapter inside the drive, following tools are required:

- a T20 torx screwdriver for removing the drive front cover
- a cutter/knife for cutting a hole to the rubber grommet at the cable lead-through.

### Selecting the cables

Use straight-connected CAT5e UTP/FTP cables with RJ-45 connectors.

### General cabling instructions

- Arrange the cables as far away from the motor cables as possible.
- Avoid parallel runs with the power cables.

## 4. Installation

### Unpacking and checking the delivery

1. Open the option package.
2. Make sure that the package contains:
  - CDPI-01 or CDPI-02 panel bus adapter (depending on the drives)
  - this manual
3. Make sure that there are no signs of damage.

### Removing the control panel from the drive

The panel bus adapter is installed in the same slot as the control panel. If a control panel is attached to the drive, remove the control panel first as follows:

- Note:** If the drive is in local control and you do not stop the drive before you remove the control panel, the motor will stop and the drive will trip to a fault.
1. If the drive is running, stop the drive.
  2. Release the control panel by pressing the clip at the upper end of the panel.
  3. Pull the upper end of the control panel out of the slot in the drive.

### Connecting the panel cabling to the drive

#### Routing the cabling outside the drive

If you have several drives on the panel bus, repeat these steps in all drives.

1. If the drive is running, stop the drive.
2. Make a hole for the panel cable on the left side of the panel bus adapter.  
If you need to chain the panel bus to another drive, make a hole for the chaining cable as well.
3. Connect the panel cable to adapter connector X101.

If you need to chain the panel bus to another drive, also connect the chaining cable to adapter connector X102.

4. Adjust the switches at the back of the adapter.

#### Termination switch (S100):

- If the adapter is connected to one drive only, set the switch to OFF.  
**Note:** If cables are long, it is recommended keep switch in ON position.
- If you have several drives on the panel bus, set the switch to ON in the last module of the bus, OFF in all other modules. The control panel terminates the bus at its end, so only the other end of the bus must be terminated.

**Bias switch (S101):** Must be OFF in all modules.

**Note:** When a third party RS-485 interface module is used for communication with the drives, bias switch needs to be set to ON if the third party module doesn't have internal biasing.

5. Attach the adapter to the drive.
  - Lead the cable(s) through the hole(s) to the front side of the adapter (a).
  - Place the bottom end of the adapter into the bottom of the slot in the drive (b).
  - Pivot the adapter and push the upper part (c) until you hear a click.
6. Secure the cable(s) to applicable cable supports.

For a panel bus chaining example, see section [Example: Chaining a control panel](#).

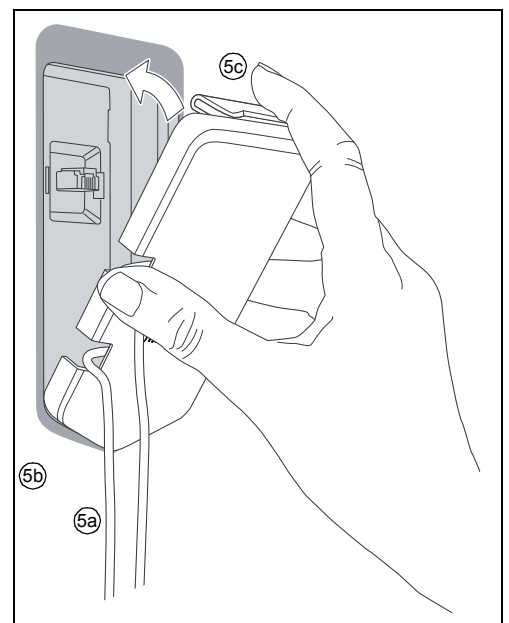
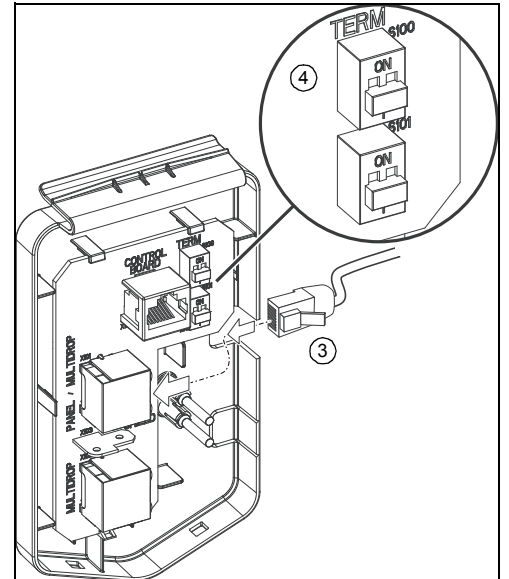
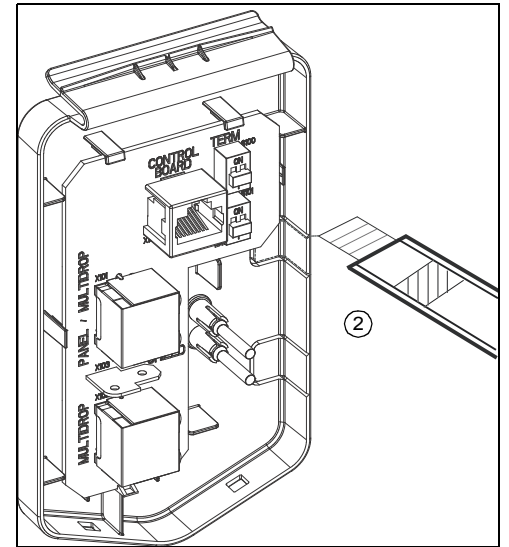

## Routing the cabling inside the drive (applicable for ACS580, ACH580, and ACQ580 drives only)

If you have several drives on the panel bus, repeat these steps in all drives.

1. Stop the drive and disconnect it from the power line. Wait for 5 minutes to let the intermediate circuit capacitors discharge before you continue.
2. Remove the drive cover.
3. Use a multimeter to make sure that there are no parts under voltage in reach.
4. Cut an adequate hole into the rubber grommet. Slide the grommet onto the cable. Slide the cable through the hole of the bottom plate and attach the grommet to the hole.
5. Route the cable first under the cable clamp (a) and then anticlockwise round the panel housing (b).
6. Connect the panel cable to adapter connector X101. See below illustration.
7. If you need to chain the panel bus to another drive:
  - repeat steps 4...5 for the chaining cable,
  - and connect the chaining cable to adapter connector X102.

8. Adjust the switches at the back of the module.

### Termination switch (S100):

- If the adapter is connected to one drive only, set the switch to OFF.
- **Note:** If cables are long, it is recommended keep switch in ON position.
- If you have several drives on the panel bus, set the switch to ON in the last module of the bus, OFF in all other modules. The control panel terminates the bus at its end, so only the other end of the bus must be terminated.

### Bias switch (S101): Must be OFF in all modules.

**Note:** When a third party RS-485 interface module is used for communication with the drives, bias switch needs to be set to ON if the third party module doesn't have internal biasing.

9. Attach the adapter to the drive.

- Place the bottom end of the adapter into the bottom of the slot in the drive.
- Pivot the adapter and push the upper part until you hear a click.

10. Adjust the cable(s) and tighten the clamp (a).

11. Put the drive cover back.

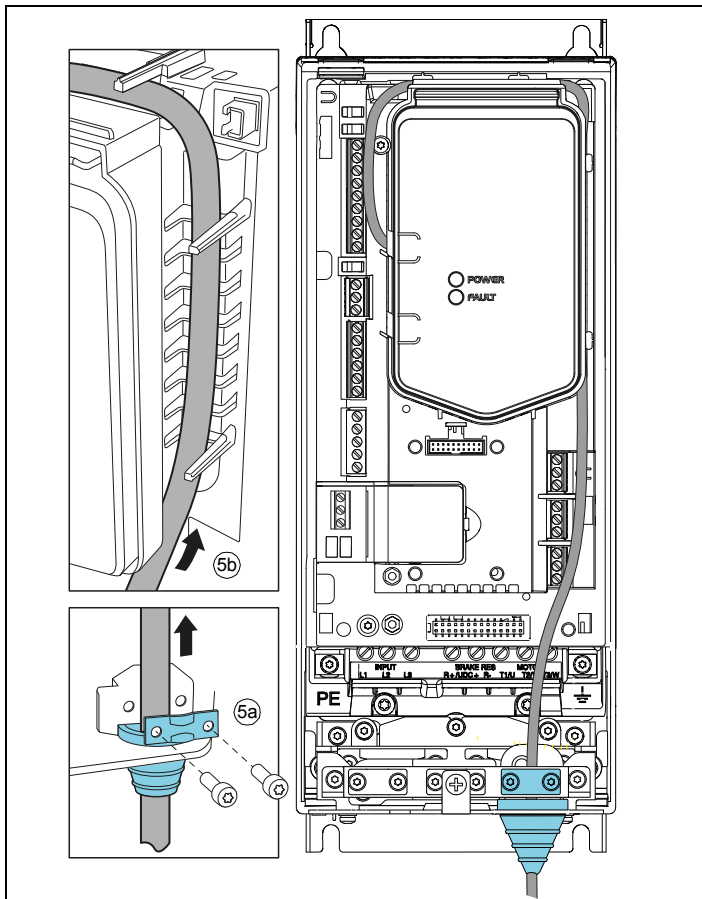

For a panel bus chaining example, see section [Example: Chaining a control panel](#).

## 5. Bus termination and chaining examples

Bus termination is required to prevent signal reflections from the bus cable ends.

### Example: Chaining a control panel

This figure shows how to chain a control panel to several drives.

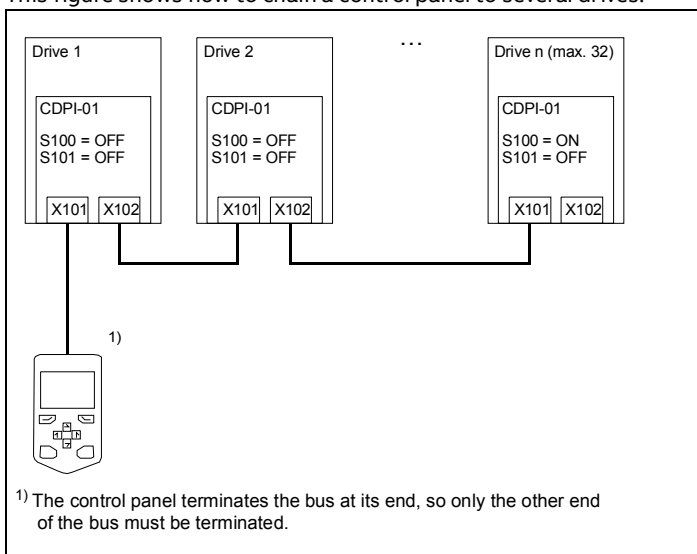

### Example: Chaining a PC through a control panel

This figure shows how to chain a PC to several drives through a control panel.

Note: When a control panel is used for a panel-to-PC connection, it cannot be used for operating the drive.

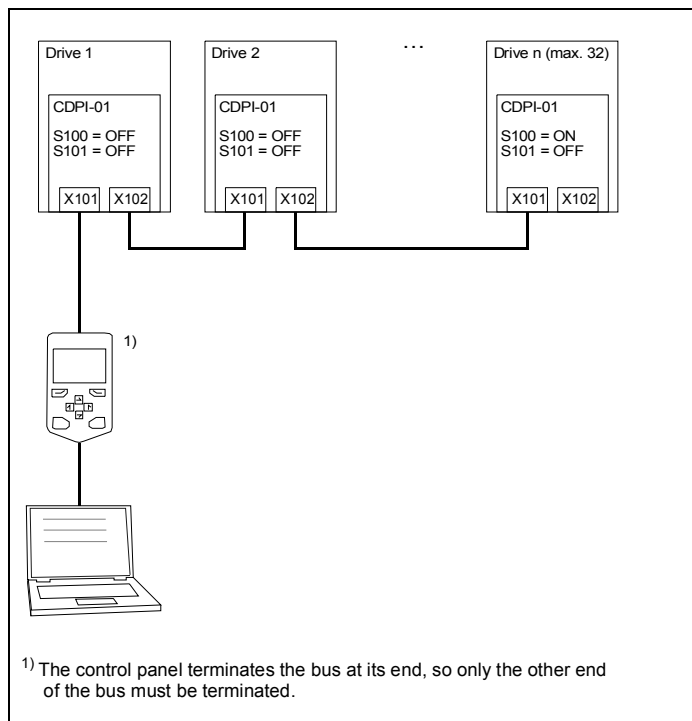

### Chaining a PC through a commercial converter

This figure shows how to chain a PC to several drives through a commercial converter.

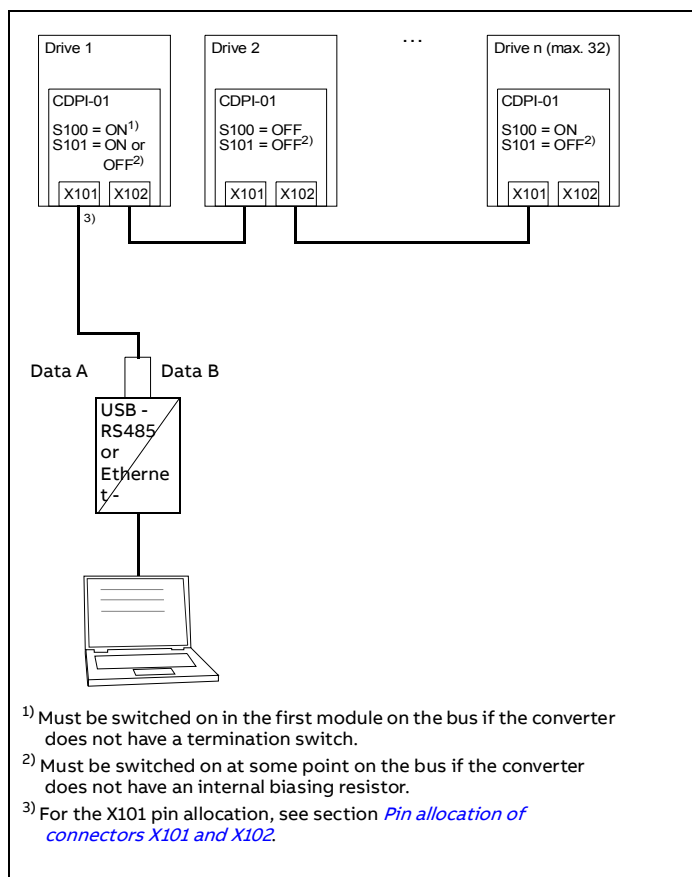

## 6. Start-up

### Before you start

Make sure that you have completed the drive start-up.

### Setting the parameters – Example for ACS580 Standard control program

If the panel bus adapter is used to chain a control panel or a PC to several drives, set the parameters of group 49 Panel port communication for each drive before you connect the drives to the bus.

1. Power up the drive.
2. Define the node ID of the drive (**49.01 Node ID number**). All devices connected to the bus must have a unique node ID. It is advisable to reserve ID 1 for spare/replacement drives because they have ID 1 as the default factory setting. Start numbering from ID 2.
3. Set the baud rate (**49.03 Baud rate**) of the drive.
  - **Note:** The baud rate has to be the same for all nodes on the bus.
4. Select a suitable value for parameter **49.05 Communication loss action value**.
  - This parameter defines the operation of the drive when the control panel communication breaks.
  - **No action (0):** No action taken.
  - **Fault (1):** Drive trips on a fault.
  - **Last speed (2):** Drive freezes the speed to the level the drive was operating at.
  - **Speed ref safe (3):** Drive sets the speed to a safe speed reference.
5. Set parameter **49.06 Refresh settings** to **Configure**, to apply the changes made to parameters 49.01...49.05.

## 7. Diagnostics

### Faults and warning messages

For the fault and warning messages concerning the panel bus adapter, see the drive manual.

## LEDs

The panel bus adapter CDPI-01 has two diagnostic LEDs (POWER and FAULT) and adapter CDPI-02 has one diagnostic LED (POWER).

Name	Color	Description
POWER	Green	Drive control unit is powered.
FAULT (applicable only for CDPI-01)	Red	There is an active fault in the drive control unit.

## 8. Technical data

### CDPI-01/-02 panel bus adapter

Degree of protection	IP21 when installed
Ambient conditions	See the drive technical data.
Package	Cardboard
Switches	<ul style="list-style-type: none"> <li>• Termination switch (S100)</li> <li>• Bias switch (S101)</li> </ul>
Connectors	<ul style="list-style-type: none"> <li>• Unshielded female connector to the drive control unit (X100, RJ-45)</li> <li>• Shielded female connector for connecting a control panel or a PC (X101, RJ-45)</li> <li>• Shielded female connector for chaining a panel bus (X102, RJ-45)</li> </ul>
Power supply	Supplied by the drive control unit
General	<ul style="list-style-type: none"> <li>• Complies with EMC standard EN 61800-3:2004</li> <li>• Printed circuit board conformal coated</li> <li>• Printed circuit board materials RoHS compliant and UL Recognized</li> </ul>

## 9. Pin allocation of connectors X101 and X102

Pin No.	Signal	Direction	Description
1	A	In / Out / Hi-Z	Data A (+)
2	B	In / Out / Hi-Z	Data B (-)
3	/TRANS	-	Not connected
4	/FAULT	-	Not connected
5	GND	-	Ground
6	GND	-	Ground
7	GND	-	Ground
8	VCC	From drive	Power supply +15...+24 V DC

### Panel bus

Bus type	RS-485
Purpose	Used as a panel bus
Maximum length	100 m
Maximum number of nodes	32 nodes (control panel/PC and drives)
Maximum transfer rate	1 Mbit/s
Medium	<ul style="list-style-type: none"> <li>• CAT5e UTP/FTP Ethernet cable, straight connection</li> <li>• Connector: RJ-45</li> </ul>

## List of related manuals

Drive manuals and guides	Code (English)
ACS580-01 manuals	9AKK105713A8085
ACH580-01 manuals	9AKK10103A0587
ACH580-31 manuals	9AKK106930A9561
ACQ580-01 manuals	9AKK106713A2709
ACS380-04 manuals	9AAK10103A6193
ACS480-04 manuals	9AKK106930A8739
ACH480-04 manuals	9AKK107046A8101

Option manuals and guides	
ACx-AP-x Assistant control panels user's manual	3AUA0000085685

You can find manuals and other product documents in PDF format on the Internet at [abb.com/drives/documents](http://abb.com/drives/documents). For manuals not available in the Document library, contact your local ABB representative.

