

NOTES:

1. All installations in hazardous locations must comply with requirements of certification drawing 2015246-CD.

J15 is ONLY found on the XFC and later versions of this board. Older versions of the 6400 will not have this connector

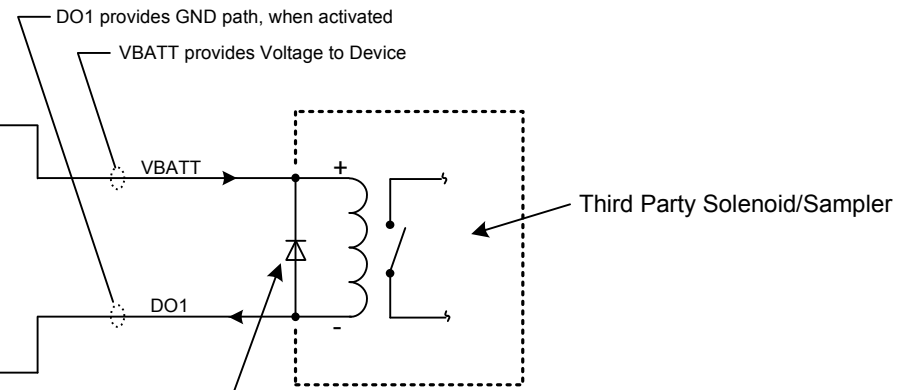
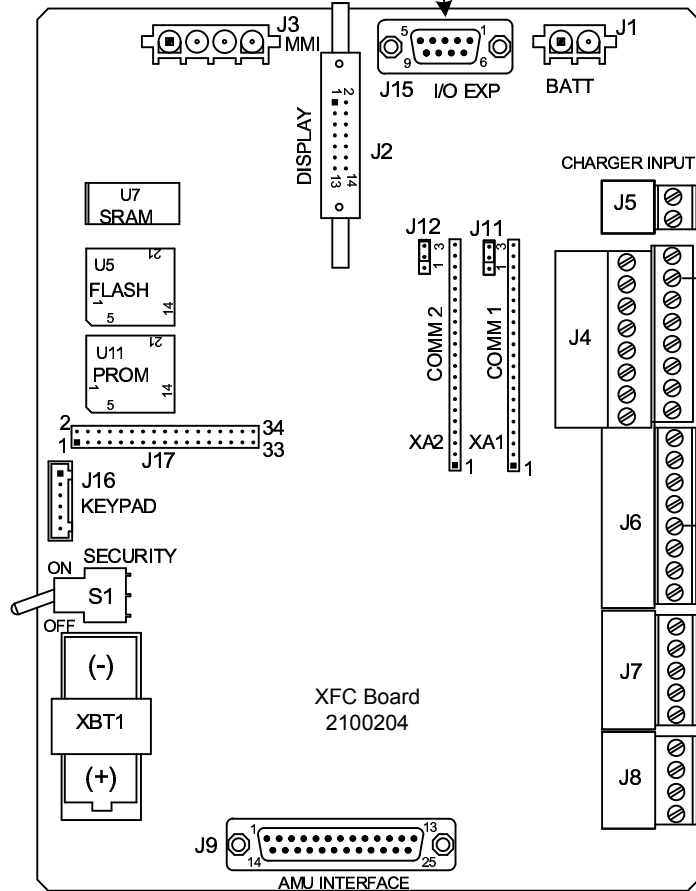

DO1 provides GND path, when activated
 VBATT provides Voltage to Device

This diode is required, when NOT included in Solenoid/Sampler (Sampler does not provide protection from inductive kickback).
 Diode should be placed as close to the solenoid as possible.

(Recommended diode: 1N5818)