

7320 Series
UV Organic Pollution Monitor

Instruction Manual

Models 7320 000 – Transmitter
with
7320 100 – Low Level Sensor
7320 200 – High Level Sensor
7320 300 – Coagulation Dose
Sensor



ABB AUTOMATION

The Company

ABB Automation is an established world force in the design and manufacture of instrumentation for industrial process control, flow measurement, gas and liquid analysis and environmental applications.

As a part of ABB, a world leader in process automation technology, we offer customers application expertise, service and support worldwide.

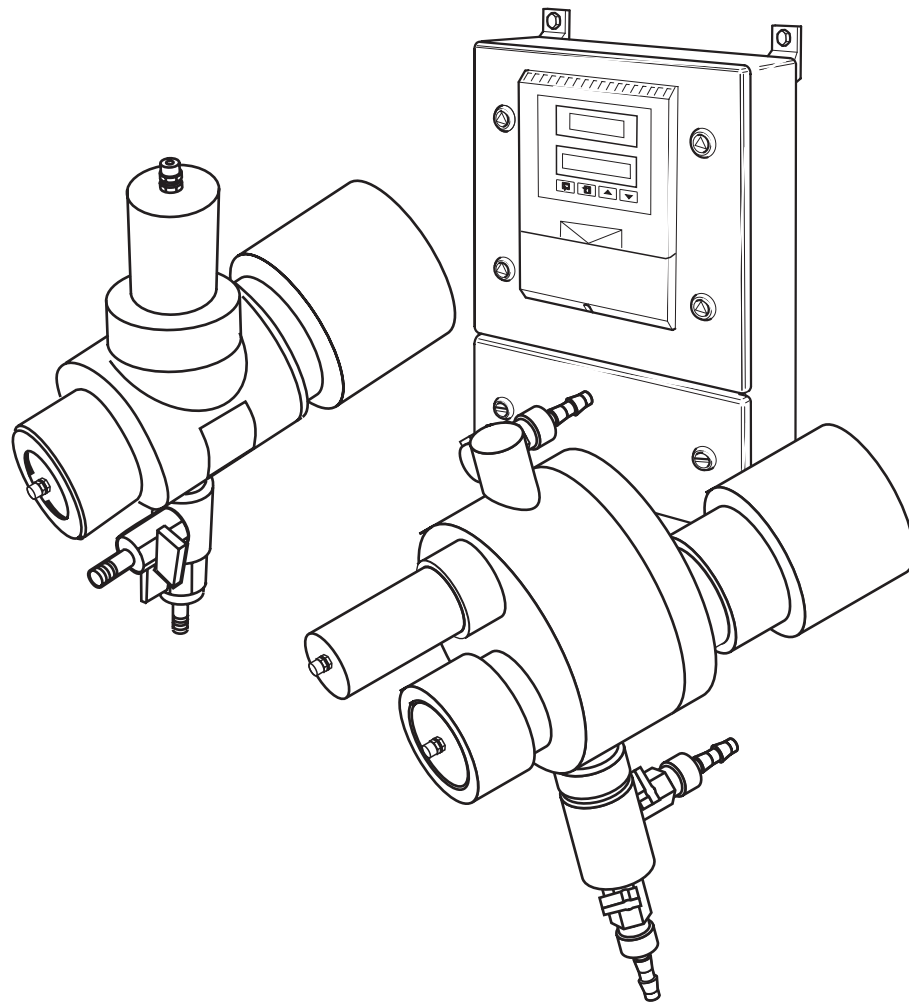
We are committed to teamwork, high quality manufacturing, advanced technology and unrivalled service and support.

The quality, accuracy and performance of the Company's products result from over 100 years experience, combined with a continuous program of innovative design and development to incorporate the latest technology.

The NAMAS Calibration Laboratory No. 0255 is just one of the ten flow calibration plants operated by the Company, and is indicative of ABB Automation's dedication to quality and accuracy.

BS EN ISO 9001



Cert. No. Q5907

EN 29001 (ISO 9001)



Lenno, Italy – Cert. No. 9/90A



Stonehouse, U.K.

Use of Instructions



Warning.

An instruction that draws attention to the risk of injury or death.



Caution.

An instruction that draws attention to the risk of damage to the product, process or surroundings.



Note.

Clarification of an instruction or additional information.



Information.

Further reference for more detailed information or technical details.

Although **Warning** hazards are related to personal injury, and **Caution** hazards are associated with equipment or property damage, it must be understood that operation of damaged equipment could, under certain operational conditions, result in degraded process system performance leading to personal injury or death. Therefore, comply fully with all **Warning** and **Caution** notices.

Information in this manual is intended only to assist our customers in the efficient operation of our equipment. Use of this manual for any other purpose is specifically prohibited and its contents are not to be reproduced in full or part without prior approval of Marketing Communications Department, ABB Automation.

Health and Safety

To ensure that our products are safe and without risk to health, the following points must be noted:

1. The relevant sections of these instructions must be read carefully before proceeding.
2. Warning labels on containers and packages must be observed.
3. Installation, operation, maintenance and servicing must only be carried out by suitably trained personnel and in accordance with the information given.
4. Normal safety precautions must be taken to avoid the possibility of an accident occurring when operating in conditions of high pressure and/or temperature.
5. Chemicals must be stored away from heat, protected from temperature extremes and powders kept dry. Normal safe handling procedures must be used.
6. When disposing of chemicals ensure that no two chemicals are mixed.

Safety advice concerning the use of the equipment described in this manual or any relevant hazard data sheets (where applicable) may be obtained from the Company address on the back cover, together with servicing and spares information.

CONTENTS

1	INTRODUCTION	2	5	PROGRAMMING	12	
1.1	Introduction	2	5.1	Programming Map	12	
1.2	Principle of Operation	2	5.2	Operating Display Page	13	
1.3	Available Systems	2	5.3	Sensor Calibration	14	
			5.4	Security Code	14	
			5.5	Set Up Parameters	15	
			5.6	Set Up Outputs	16	
			5.7	Factory Settings	16	
2	MECHANICAL INSTALLATION	3	6	MAINTENANCE	17	
2.1	Siting Requirements	3	6.1	Standard Solutions	17	
2.1.1	Monitor	3	6.1.1	Zero Standard	17	
2.1.2	Flowcell Assembly	3	6.1.2	Span Standard	17	
2.2	Installing the Monitor	4	6.1.3	Calibration Checks	17	
2.3	Installing the Flowcell	5	6.2	Scheduled Servicing	17	
2.4	Mounting the De-bubbler	7	6.2.1	Cleaning the Flowcell	17	
2.4.1	Set Up Procedure for Optional De-bubbler	7	6.2.2	Dismantling the Flowcell for Cleaning and Wiper Maintenance	18	
3	ELECTRICAL CONNECTIONS	8	6.3	Unscheduled Servicing	22	
3.1	Access to Terminals	8	6.3.1	Monitor Diagnostic Information	22	
3.2	Connections, General	8	6.3.2	Unstable or Erratic Readings	22	
3.2.1	Relay Contact Protection and Interference Suppression	8	6.4	Replacing the Emitter and Receiver Modules	23	
3.3	Monitor Connections	9	6.4.1	Changing the Modules	23	
3.3.1	Out of Sample Alarm Input Connections	10	6.4.2	Adjusting the Emitter Brightness	23	
3.3.2	Alarm Relay Connections	10				
3.3.3	Out of Service Alarm	10				
3.4	Selecting the Mains Voltage	10				
3.5	Start Up	10	7	SPECIFICATION	25	
4	CONTROLS AND DISPLAYS	11	8	SPARES	26	
4.1	Displays	11				
4.2	Switch Familiarisation	11				
				APPENDIX	27	
				A.1	Inferred Units	27

1 INTRODUCTION

1.1 Introduction



Warning. This instrument uses a high intensity light source which emits ultraviolet (UV) radiation and must NOT be viewed with the naked eye. Under normal operating conditions it is not possible to see the light source, but if the sensor is dismantled with the power applied, it may be possible to expose the eyes to the strobe flash.

Many organic compounds commonly found in water and waste water strongly absorb ultraviolet radiation. Although different organic compounds absorb to different extents each individual compound absorbs in proportion to its concentration. The measurement of UV absorption can therefore be used to obtain a useful indication of the aggregate concentration of dissolved organic constituents in a water sample. The measurement is usually made at a wavelength of 254 nm.

In many cases strong, site-specific correlations will exist between UV absorption and organic carbon content, e.g. total organic carbon (TOC), both in clean waters and in industrial effluents. The measurement can also be useful in monitoring organic removal by coagulation or other water treatment processes.

1.2 Principle of Operation

The monitor employs a broad-spectrum xenon strobe lamp to generate pulses of light which pass through the sample water in the flowcell to a filtering and detection system. The received light pulses are analysed at two wavelengths: the measurement wavelength of 254 nm and the reference wavelength of 400 nm, at which the sample constituents of interest do not absorb. This dual light path system provides information which allows the measured value to be corrected for any turbidity due to suspended matter in the sample. The monitor is calibrated with a pure solution of a suitable organic compound of known carbon content.

An automatic, microprocessor-controlled, dual-wiper system cleans the flowcell optical windows periodically to ensure that the cell remains functional. Samples containing large solids and/or very high concentrations of solids must be pre-filtered.

1.3 Available Systems – Fig. 1.1

The 7300 Series comprises the following models:

- The 7320/1000 low range analyzer primarily for use in clean water applications, such as final water.
Range: **0 to 20 mg/l** maximum.
- The 7320/2000 high range analyzer satisfies intake protection applications.
Range: **0 to 100 mg/l** maximum.
- The 7320/3000 high range coagulation analyzer is designed to monitor the raw water in potable water treatment plants to predict the coagulant dose.

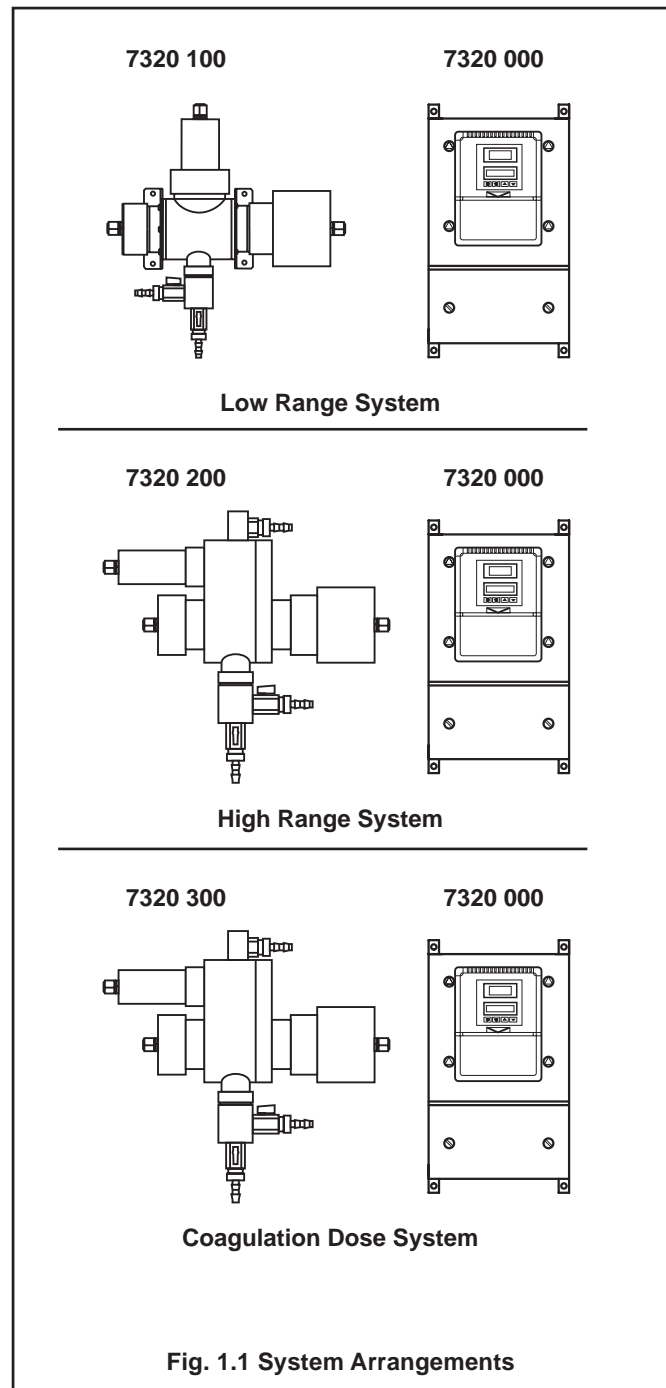

2 MECHANICAL INSTALLATION



Caution. Do not damage the equipment by dropping, scraping or otherwise abusing it during the installation process. Although the equipment is ruggedly constructed, it contains precision optical components which may be damaged if subjected to impacts or shock loading.

2.1 Siting Requirements – Fig. 2.1

2.1.1 Monitor



Caution.

- Mount in a location free from excessive vibration.
- Mount away from harmful vapors and dripping fluids.

The monitor must be fixed to a wall or support in such a position as to make reading the displays and operating the keypad convenient. It is advisable to install a suitably switched and fused isolating box to the right of the monitor, in a position which allows the power to be switched on or off while standing in front of the display.

2.1.2 Flowcell Assembly

The flowcell assembly is supplied on mounting brackets. These must be fixed to a suitable vertical surface such that convenient servicing and calibration is afforded. Allow suitable space to the left and right of the unit for accessing the sensors.



Notes.

- For ease of use it is recommended that the flowcell be mounted at chest height.
- The bracket fitted to the emitter module on a high range flowcell is in two parts – see Fig. 2.5.

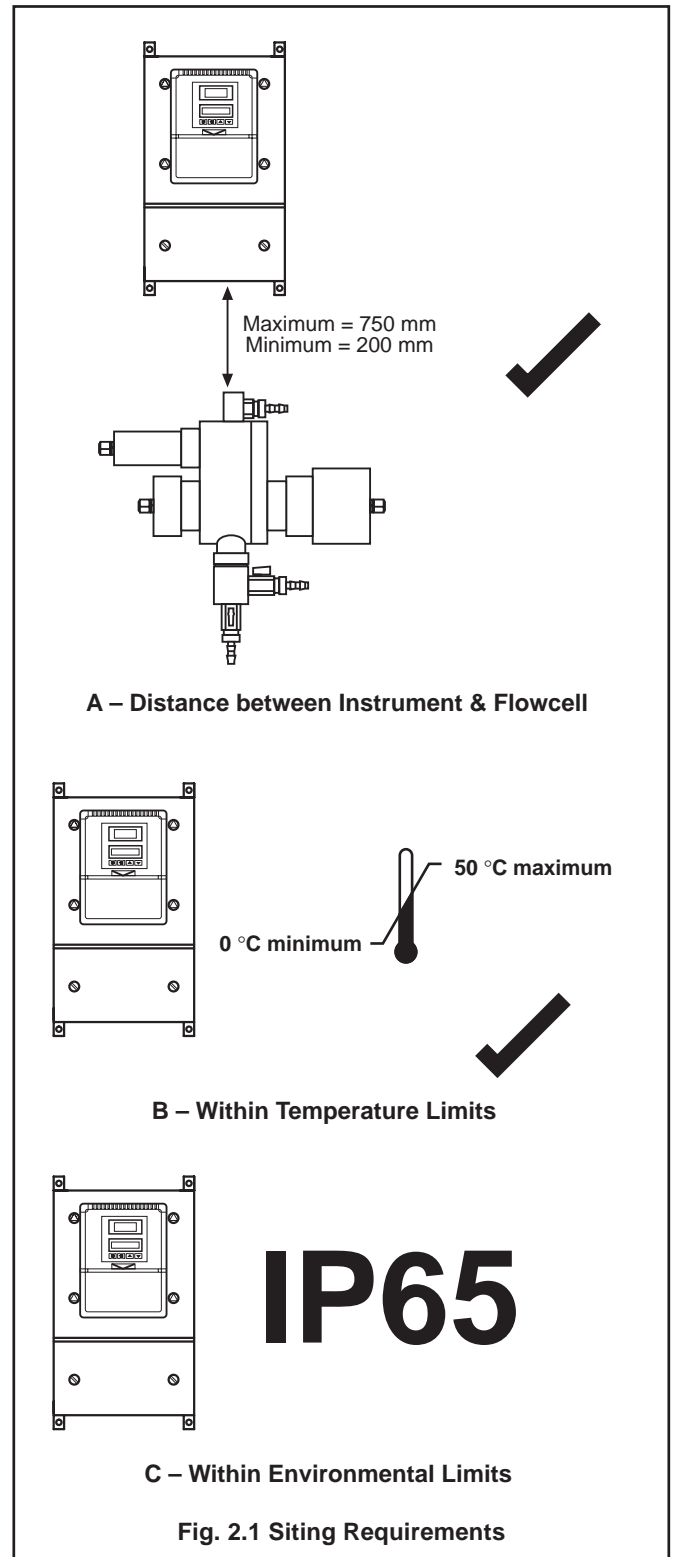

...2 MECHANICAL INSTALLATION

2.2 Installing the Monitor – Figs. 2.2 and 2.3

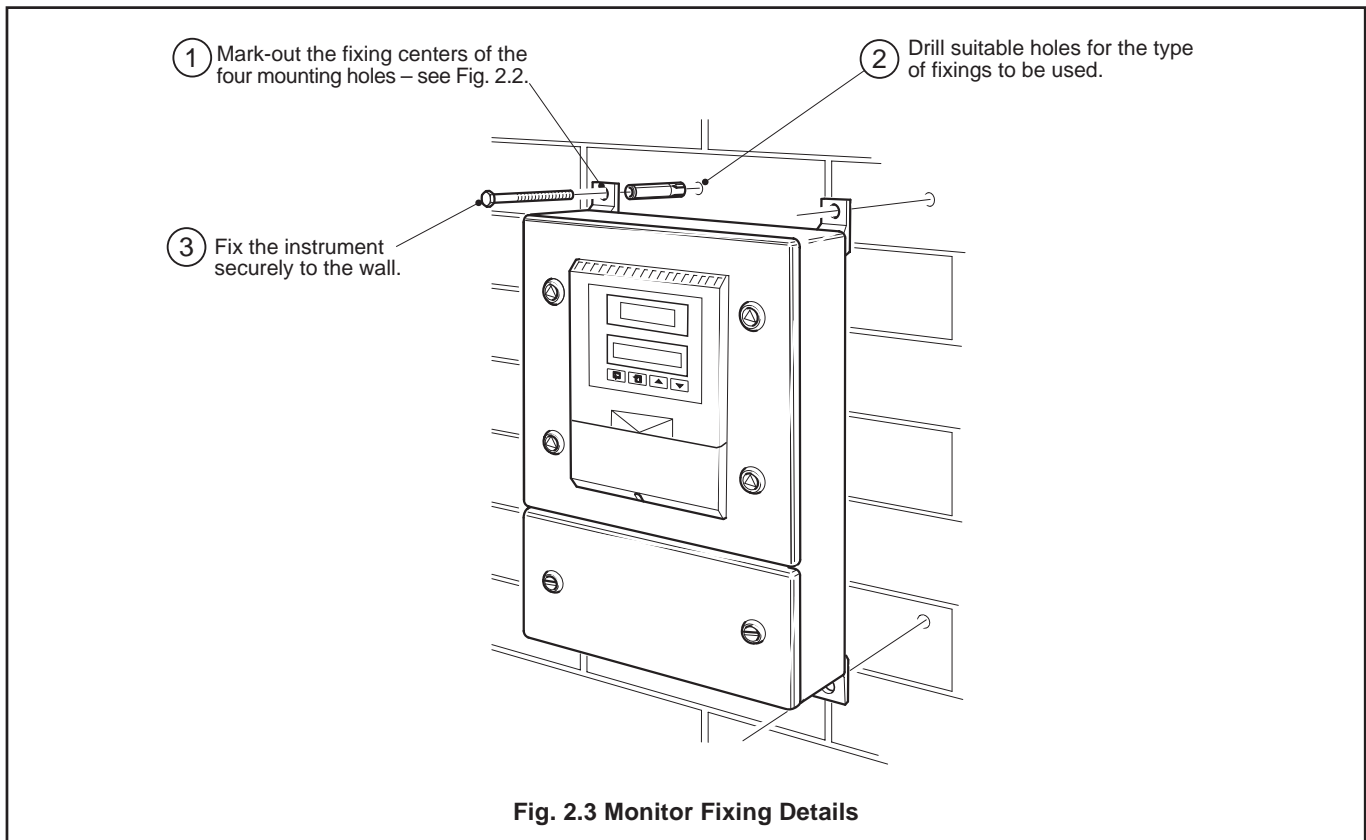
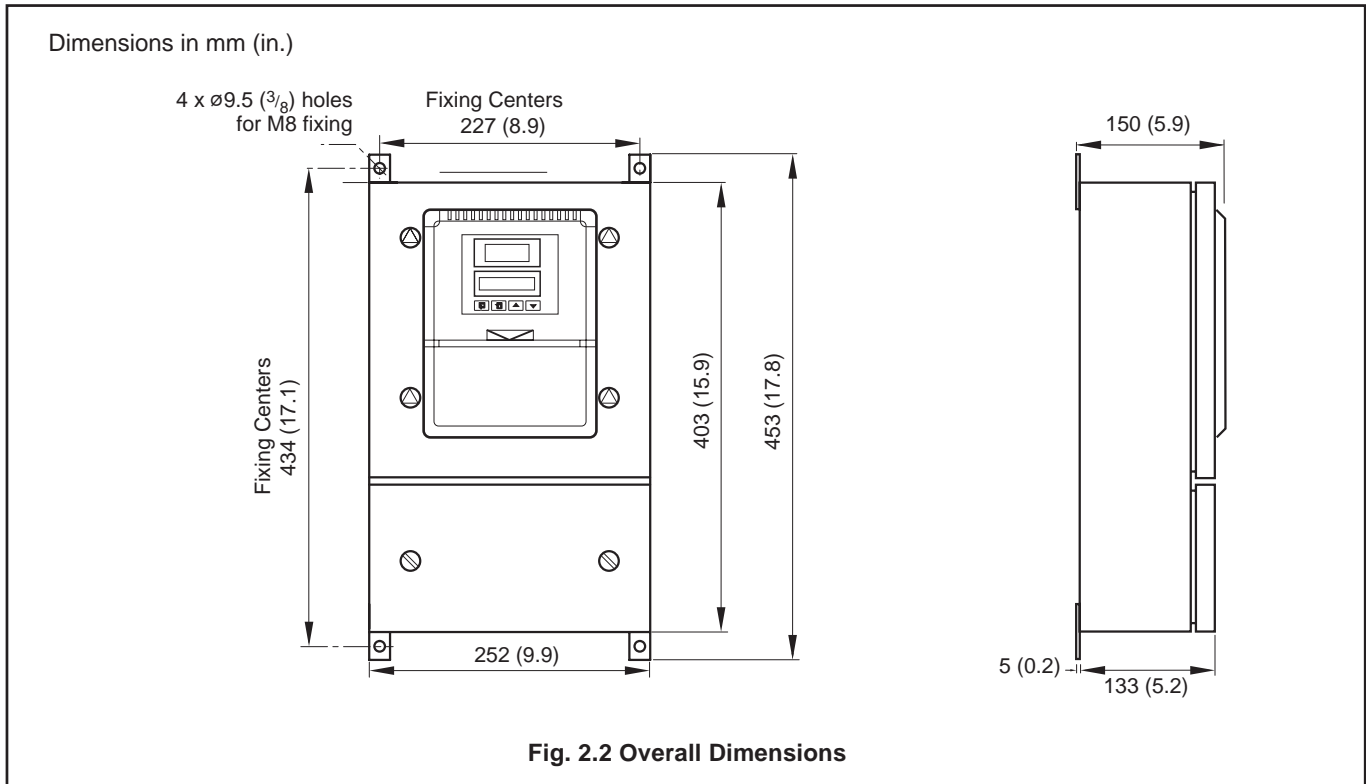

2.3 Installing the Flowcell – Figs. 2.4 and 2.5



Notes.

- Connecting pipework may be flexible plastic or rigid PVC, polypropylene or metal depending on the installation.
- Isolating valves should be fitted to allow removal of the instrument.
- Space should be left on each side of the assembly to allow access to the sensors.

For maintenance purposes the following minimum clearances are recommended:

- | | | |
|-------|------------------------|--------|
| Left | (for receiver removal) | 100 mm |
| Right | (for emitter removal) | 100 mm |
| Top | (for cleaner removal) | 200 mm |

Dimensions in mm

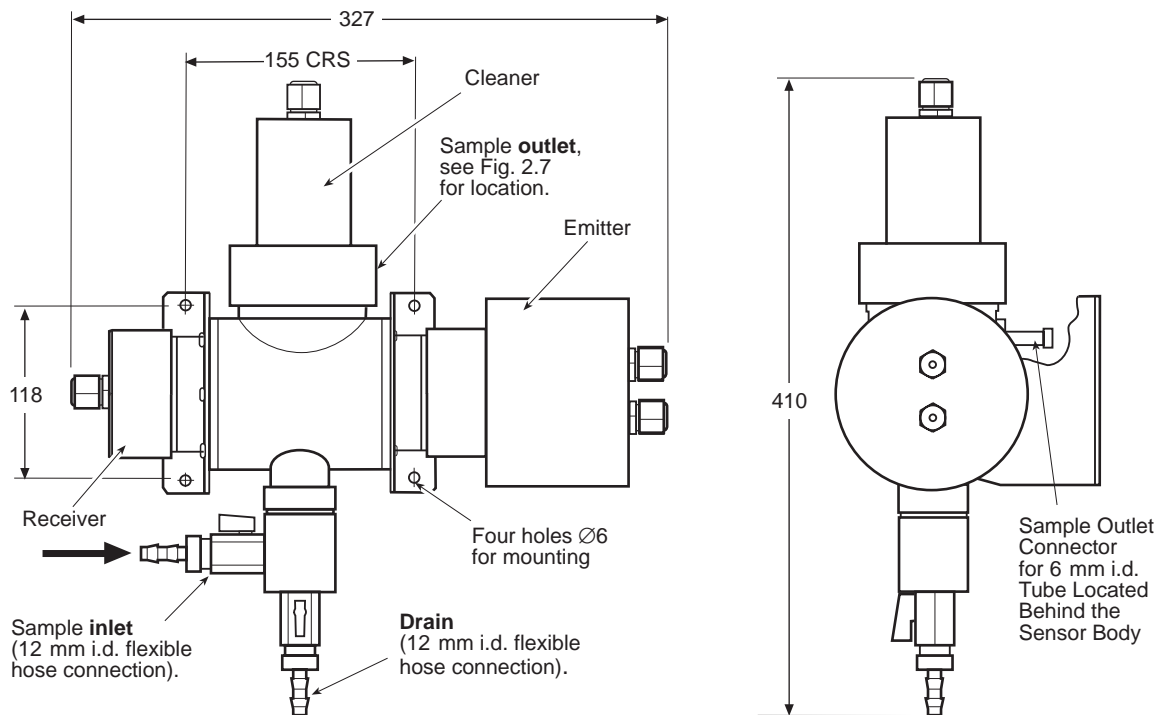

Fig. 2.4 Overall Dimensions and Mounting Details of 7320 100 (Low Range Sensor)

..2 MECHANICAL INSTALLATION

For maintenance purposes the following minimum clearances are recommended:

Left	(for receiver removal)	150 mm
Right	(for emitter removal)	100 mm
Top	(for filling with standard solution)	200 mm

Dimensions in mm

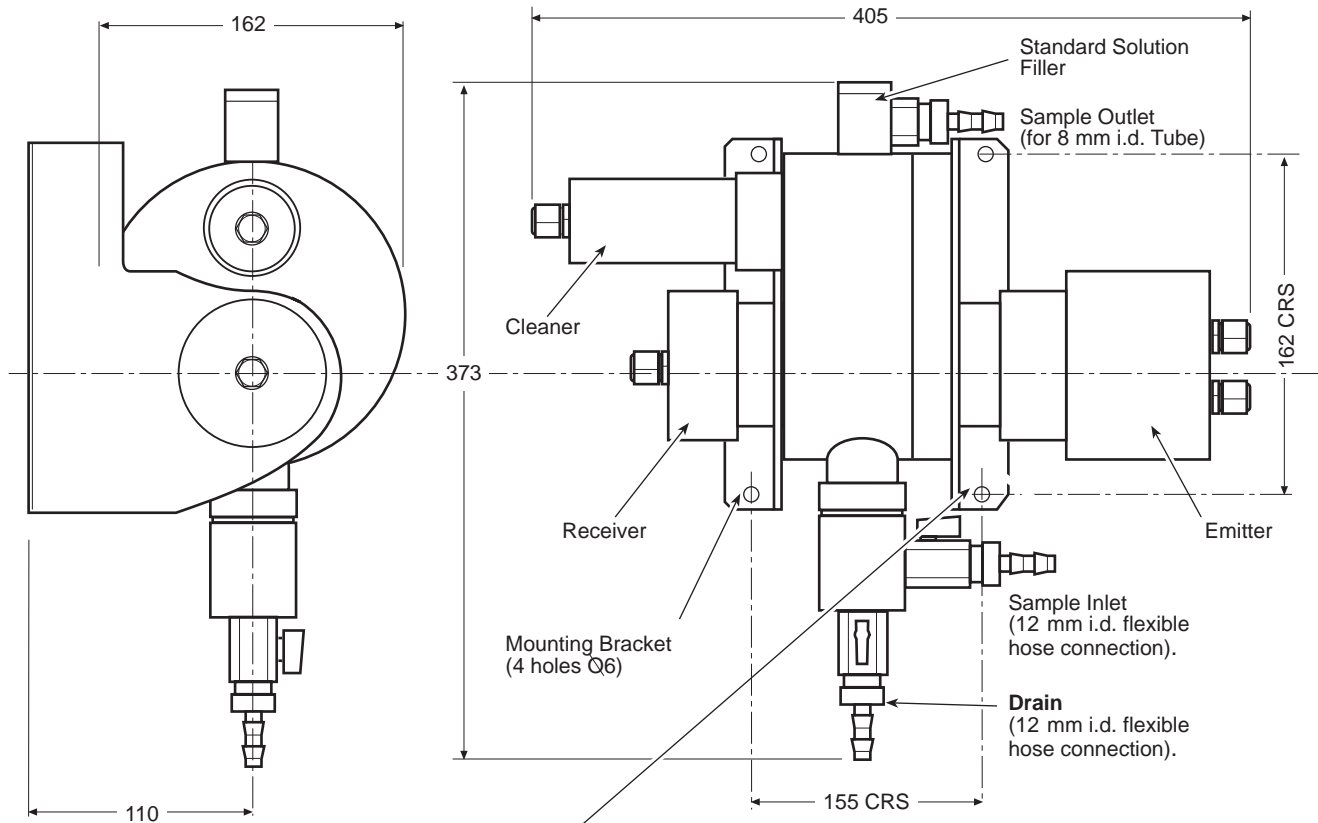

Bracket Fixed to
Flowcell Cover,
Emitter side

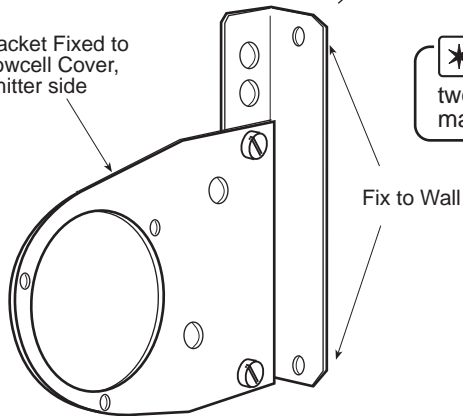

***** **Note.** The emitter end mounting bracket is in two parts to facilitate emitter module removal during maintenance. See Section 6 - *Maintenance*.

Fig. 2.5 Overall Dimensions and Mounting Details of 7320 200 and 7320 300 (High Range Sensors)

2.4 Mounting the De-bubbler – Fig. 2.6

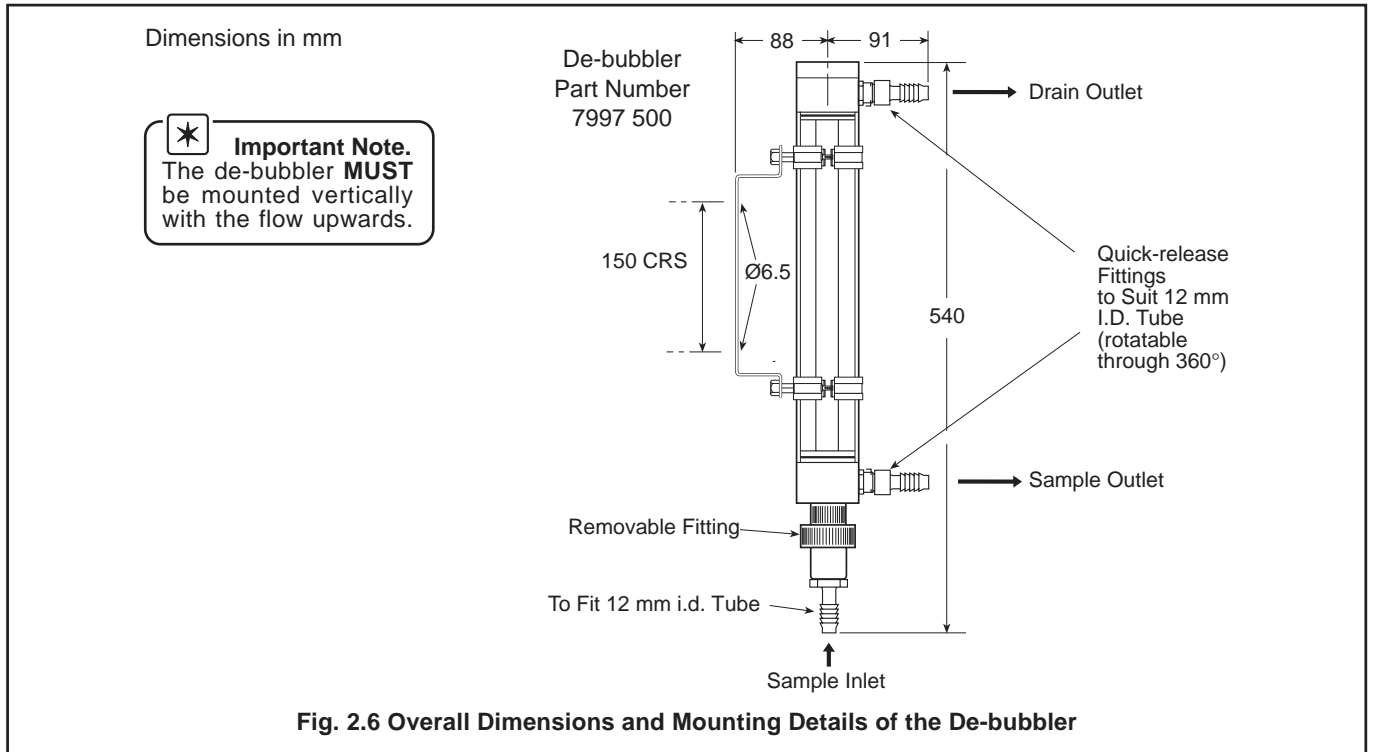

2.4.1 Set Up Procedure for Optional De-bubbler – Fig. 2.7

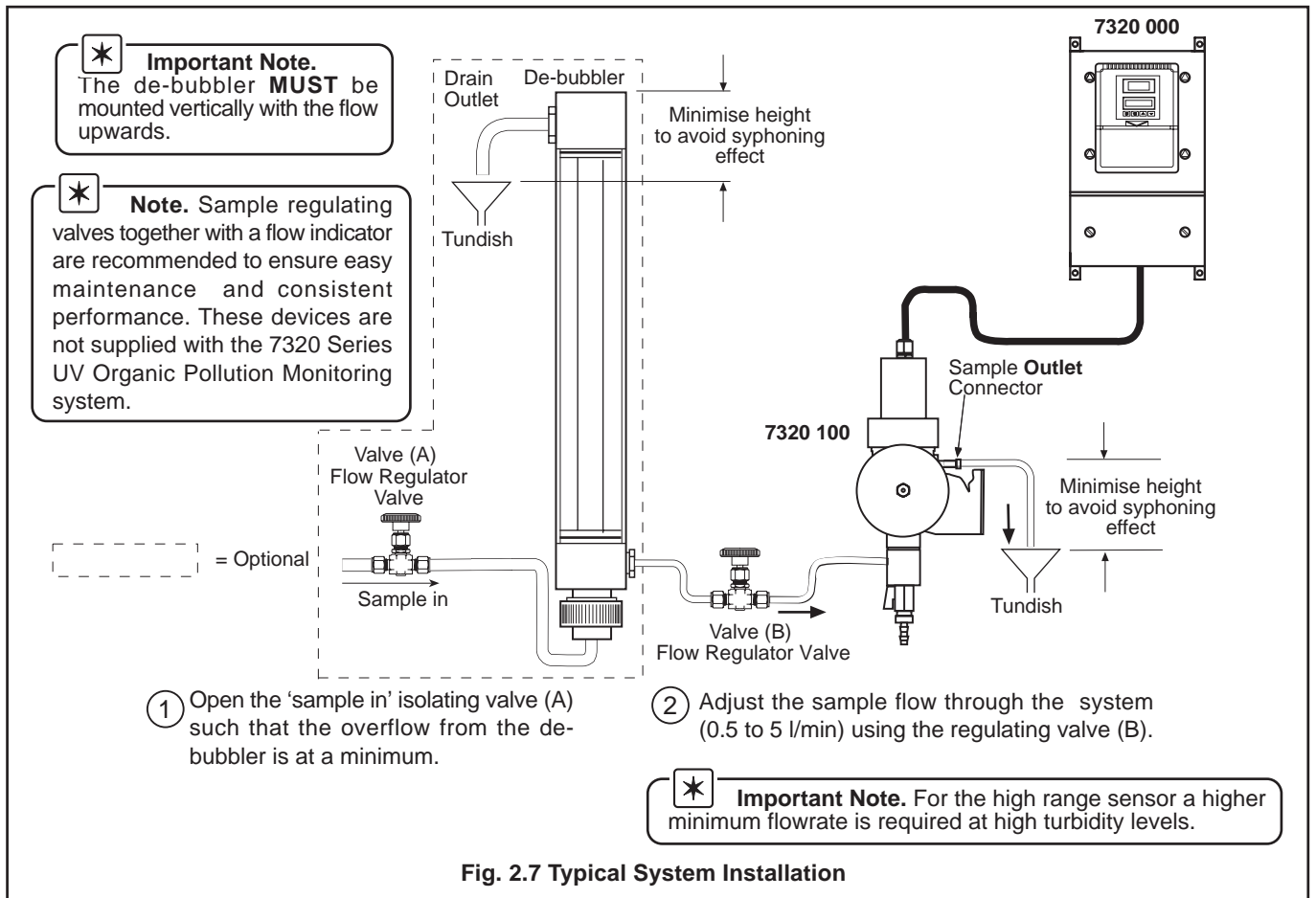

3 ELECTRICAL CONNECTIONS



Warning.

- Although certain instruments are fitted with internal fuse protection, a suitably rated external protection device, e.g. fuse or miniature circuit breaker (m.c.b.), must also be fitted by the installer.
- Before making any connections, ensure that the power supply, any high voltage-operated control circuits and high common mode voltage are switched off.

3.1 Access to Terminals – Fig. 3.1

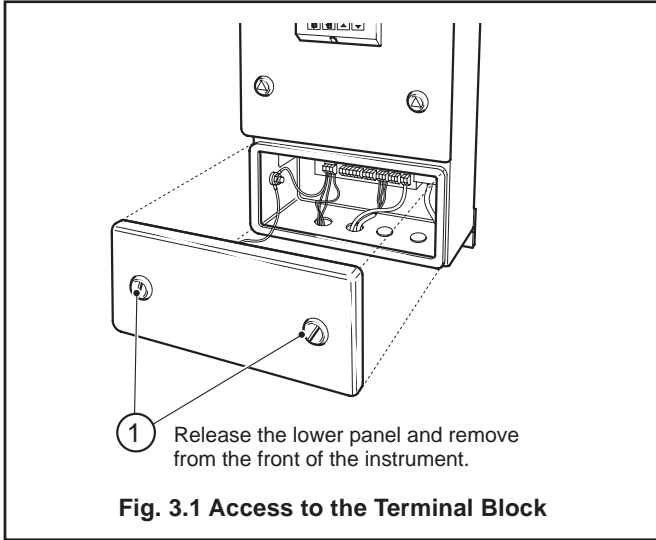

Fig. 3.1 Access to the Terminal Block

3.2 Connections, General



Warning. The power supply earth (ground) **must** be connected to ensure safety to personnel, reduction of the effects of RFI and correct operation of the power supply interference filter.



Information.

- **Earthing (grounding)** – stud terminal(s) is fitted to the transmitter case for bus-bar earth (ground) connection – see Fig. 3.3.
- **Cable routing** – always route the signal cable and mains-carrying/relay cables separately, ideally in earthed (grounded) metal conduit. Ensure that the cables enter the transmitter through the glands nearest the appropriate screw terminals and are short and direct. Do not tuck excess cable into the terminal compartment.
- **Cable glands & conduit fittings** – ensure a moisture-tight fit when using cable glands, conduit fittings and blanking plugs/bungs (M20 holes). The M16 glands ready-fitted to wall-mounted instruments accept cable of between 4 and 7 mm diameter.



Information.

- **Relays** – the relay contacts are voltage-free and must be appropriately connected in series with the power supply and the alarm/control device which they are to actuate. Ensure that the contact rating is not exceeded. Refer also to Section 3.2.1 for relay contact protection details when the relays are to be used for switching loads.
- **Current output** – Do not exceed the maximum load specification for the selected current retransmission range – see **SPECIFICATION**, Section 7. Since the current output is isolated the –ve terminal **must** be connected to earth (ground) if connecting to the isolated input of another device.

3.2.1 Relay Contact Protection and Interference Suppression – Fig. 3.2

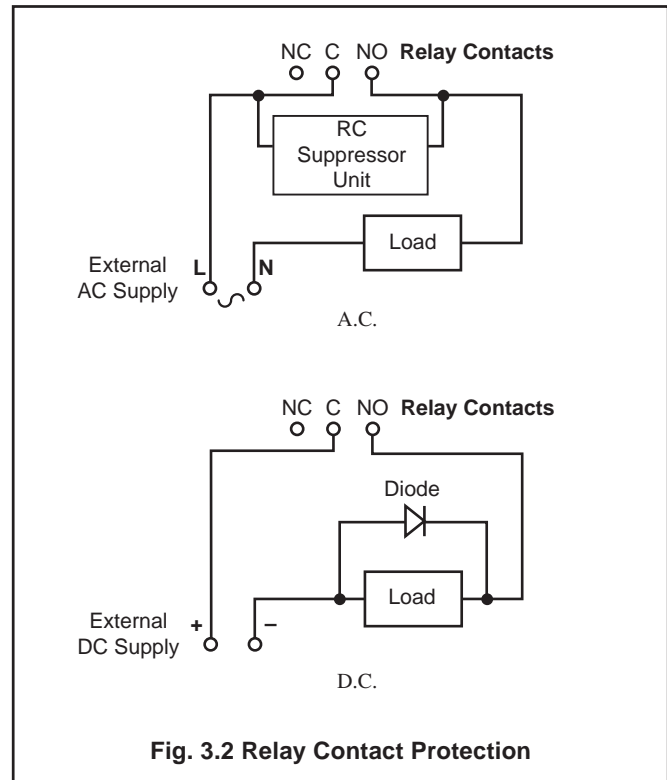

Fig. 3.2 Relay Contact Protection

3.3 Monitor Connections – Fig. 3.3

Note. Refer to Fig. 3.1 for Access to Terminals.

Caution. Slacken terminal screws fully before making connections.

Warning. The power supply earth (ground) **must** be connected to ensure safety to personnel, reduction of the effects of RFI and correct operation of the power supply interference filter.

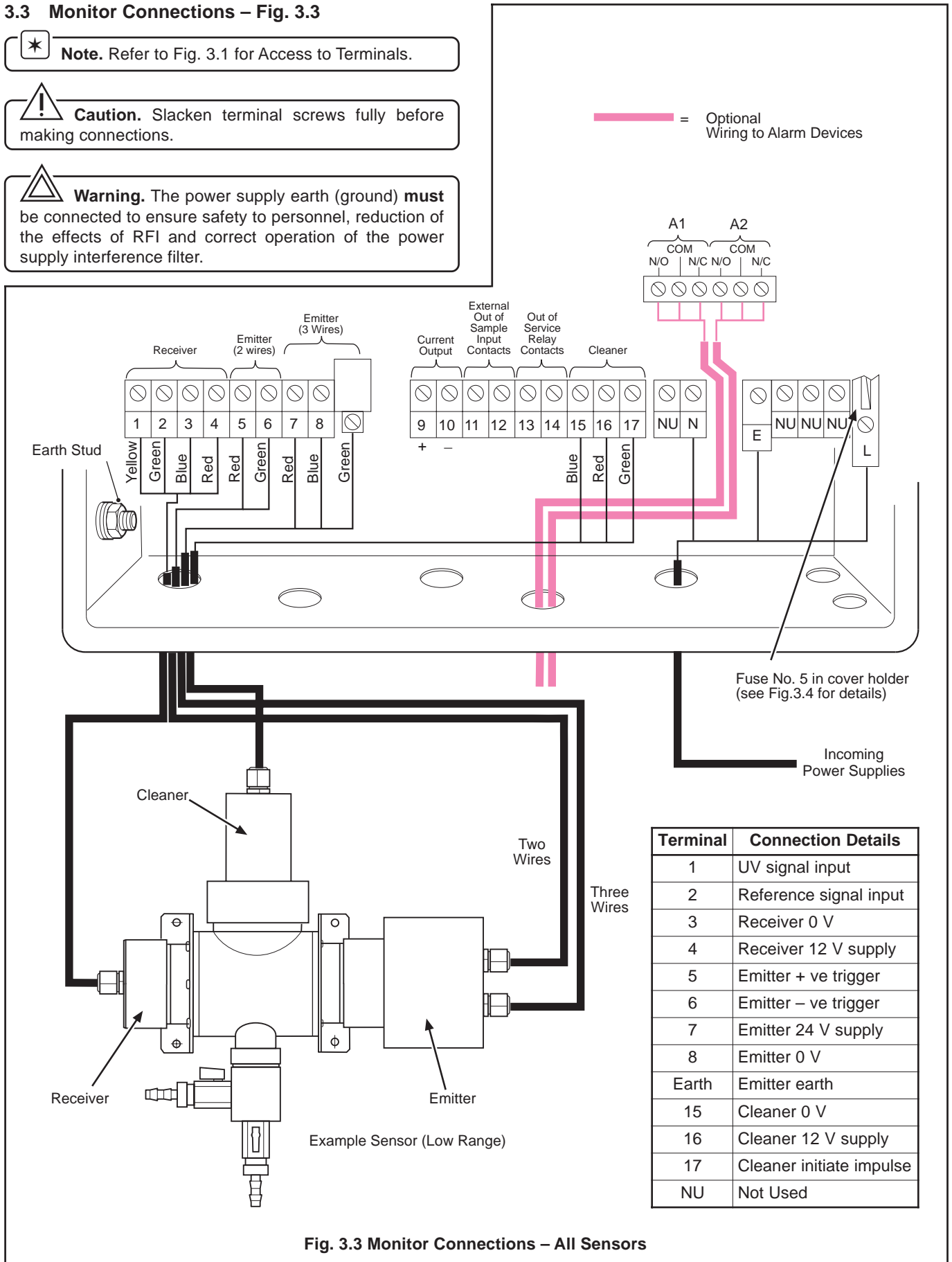

Fig. 3.3 Monitor Connections – All Sensors

...3 ELECTRICAL CONNECTIONS

3.3.1 Out of Sample Alarm Input Connections

A digital input is supplied which can be connected to a low flow indicator or sump level switch. This can be used to give indication of the loss of the sample flow or an unacceptable drop in water level. The input is linked to the internal system relay when selected in the program.

The input can be configured in the software to accept an input from a device which has normally open or closed contacts – see Section 5.5.

If this input is not required, leave it open circuit.

3.3.2 Alarm Relay Connections

Up to two alarm relays can be provided with connections to the single set of contacts for each alarm – see Fig. 3.3. Alarms can be connected using suitable signal cable.

The operating sense of the relays can be changed using the service programs – see Section 5.6, Set Up Outputs. This enables normally open or normally closed configurations.

3.3.3 Out of Service Alarm

This alarm can be remotely transmitted via an internal relay provided. This is a fail-safe relay which is de-energised in the event of a diagnostics alarm – see Section 6.3.1 for details.

3.4 Selecting the Mains Voltage – Fig. 3.4

3.5 Start Up

When all sample/drain connections have been made and electrical/signalling installation has been completed and checked, switch on the power supply.

Proceed to Section 5 for programming details.

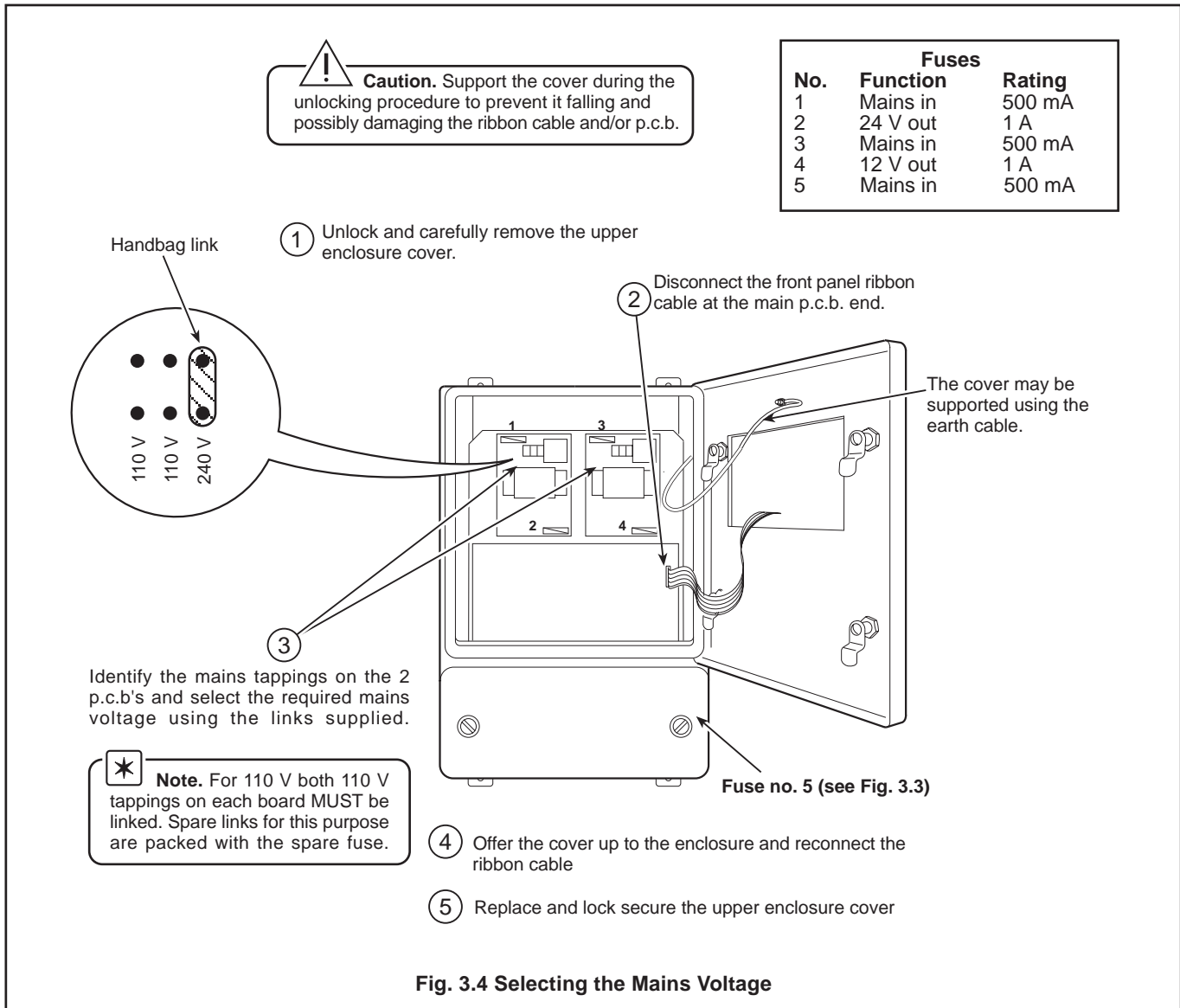

4 CONTROLS AND DISPLAYS

4.1 Displays – Fig. 4.1

The upper display window comprises a 4-digit, 7-segment digital line and shows actual values (Concentration) of dissolved organics. The lower display comprises two 16-character dot-matrix lines showing the current program parameters.

4.2 Switch Familiarisation – Figs 4.1 and 4.2

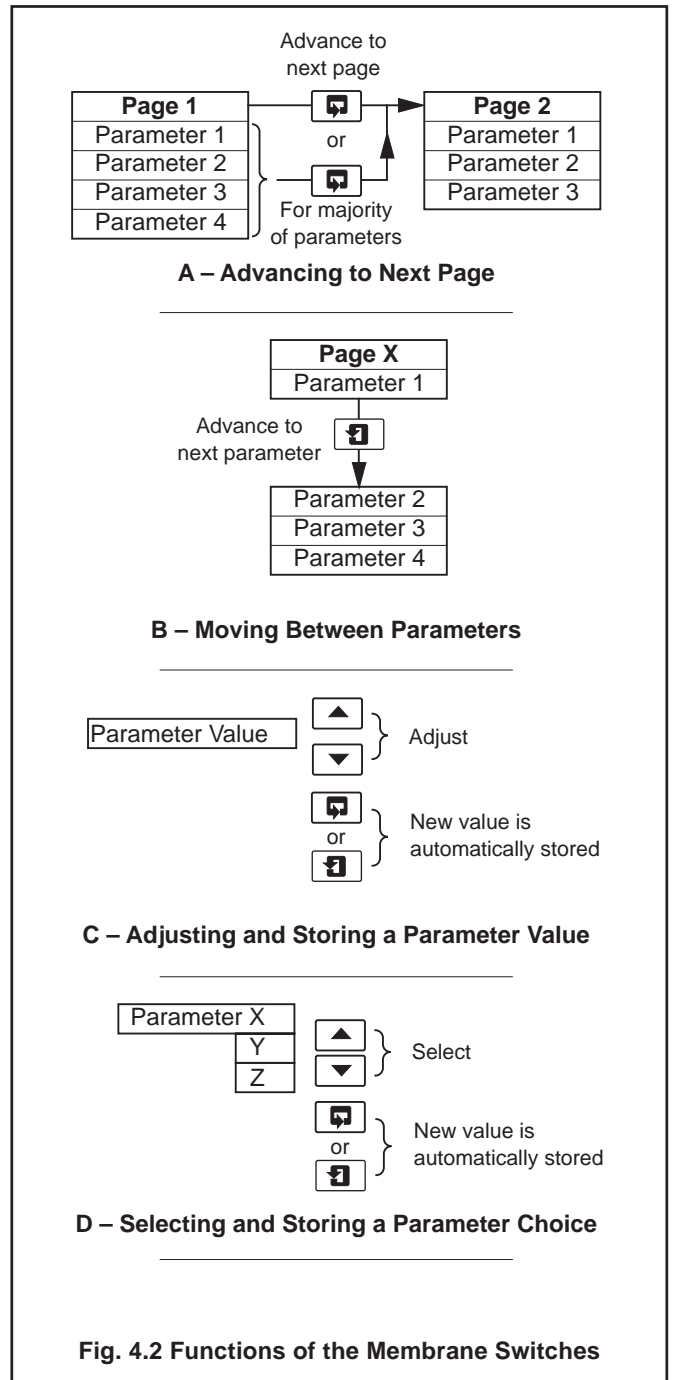
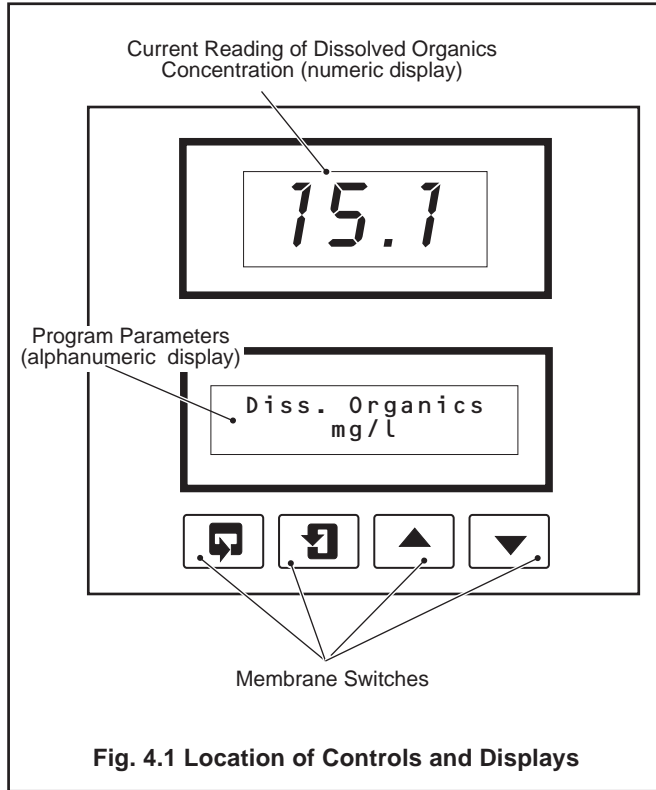

5 PROGRAMMING

5.1 Programming Map – Fig. 5.1

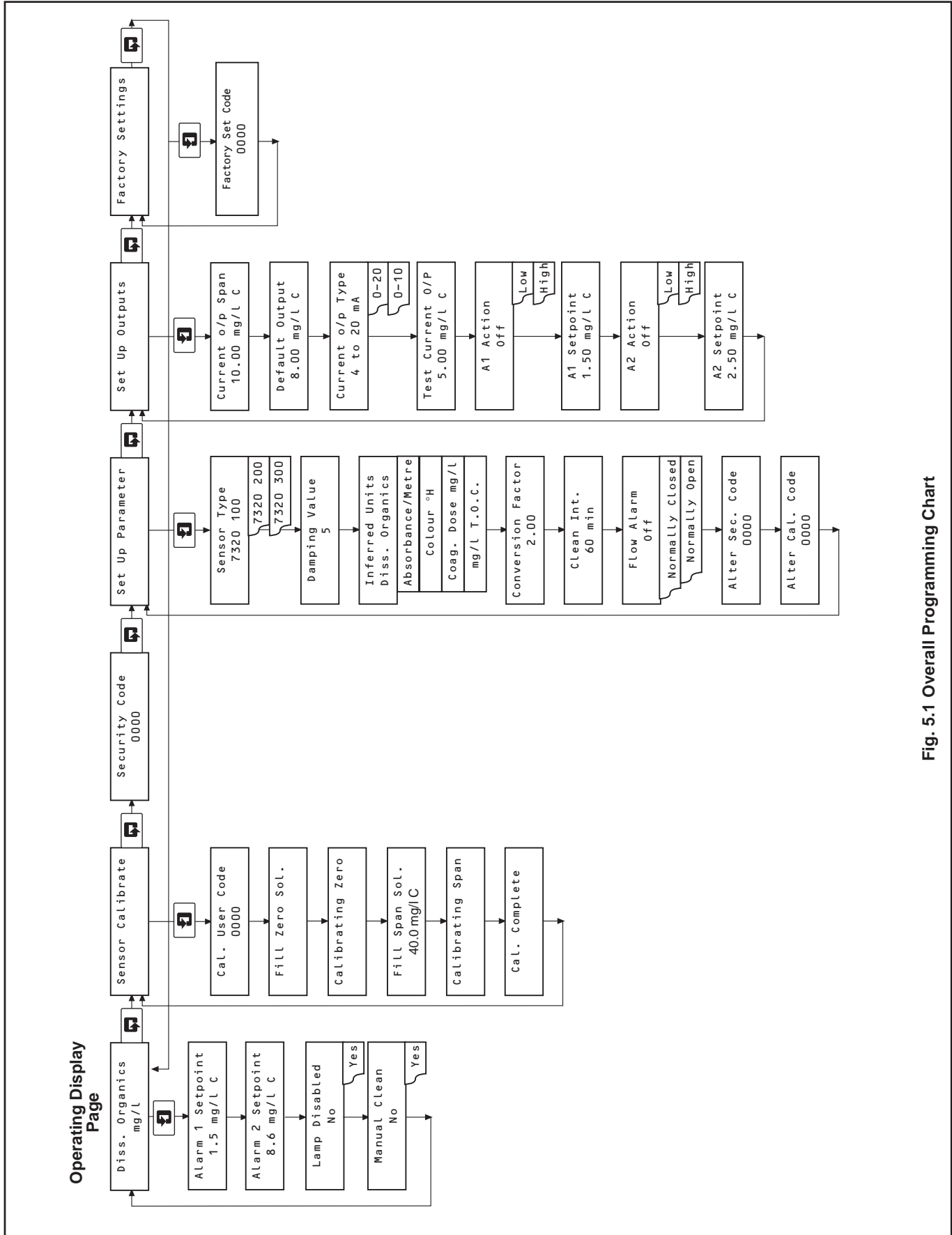
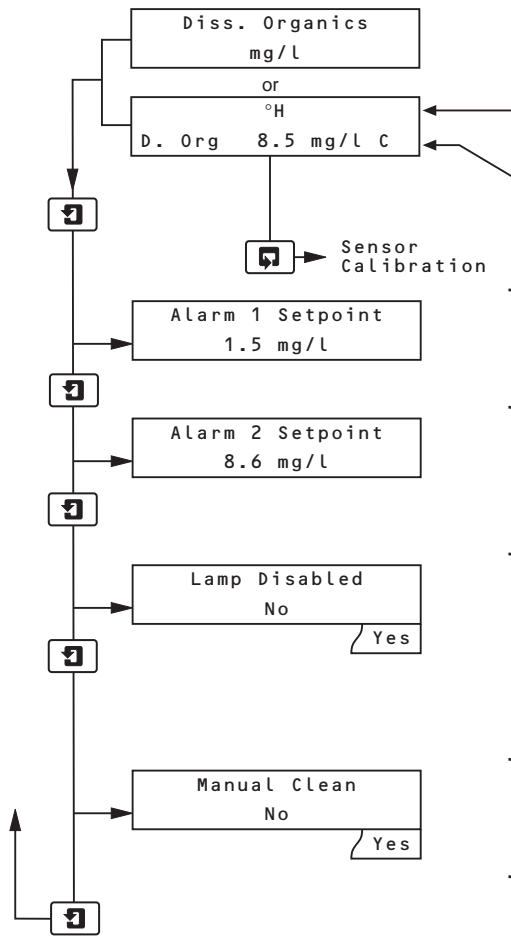

Fig. 5.1 Overall Programming Chart

5.2 Operating Display Page

Note. This is the default page. The programme returns to this point from any of the programming pages if no data has been entered after four minutes.



Dissolved Organics Mode Operating Page

Display in **inferred units** (see Appendix)
Absorbance/metre; colour °H; Coag. Dose mg/l; mg/l T.O.C.
Equivalent value in mg/l Dissolved Organics.

This is for display only. See **Set Up Outputs Page** for programming details.

This is for display only. See **Set Up Outputs Page** for programming details.

Switching the Lamp On/Off

In the interests of safety it is essential that the lamp is switched off before doing any maintenance on the sensor. When off, **Lamp Disabled** is displayed in the lower window of the **Diss. Organics** page; the top window will be blank.

Press the switch to disable the lamp and to switch the lamp back on.

Manual Cleaning

Press the switch to change **No** to **Yes** and press the switch to start a manual clean.

Return to top of **Operating Display Page**.

...5 PROGRAMMING

5.3 Sensor Calibration

Note. Output is held during a calibration.

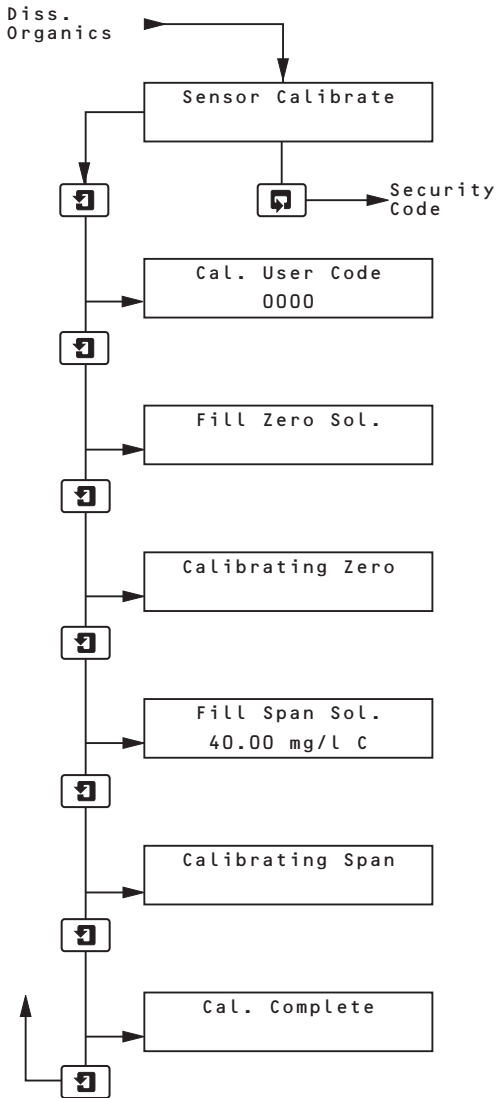

Sensor Calibration Page

Calibration Access Code

Enter the code in the range 0000 to 9999.

Fill the flowcell with carbon-free de-ionized water.

This message is displayed for about one minute, then changes to **F i l l Span Sol..**

Fill the flowcell with the required calibration solution.

7320 100 (low range)..... 10.00 mg/l C

7320 200 (high range) 40.0 mg/l C

7320 300 (coagulation dose) ... 40.0 mg/l C



This message is displayed for about one minute, then changes to **C a l . Complete.**

Return to top of **Sensor Calibration Page.**

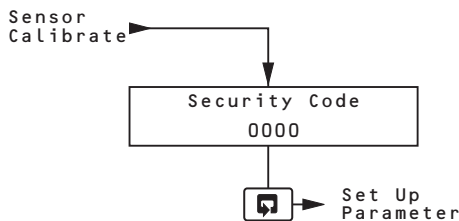
5.4 Security Code



Secure Parameter Access

Use the  and  switches to enter the appropriate security code between 0000 and 9999.

Advance to **Set Up Parameter Page.**

5.5 Set Up Parameters

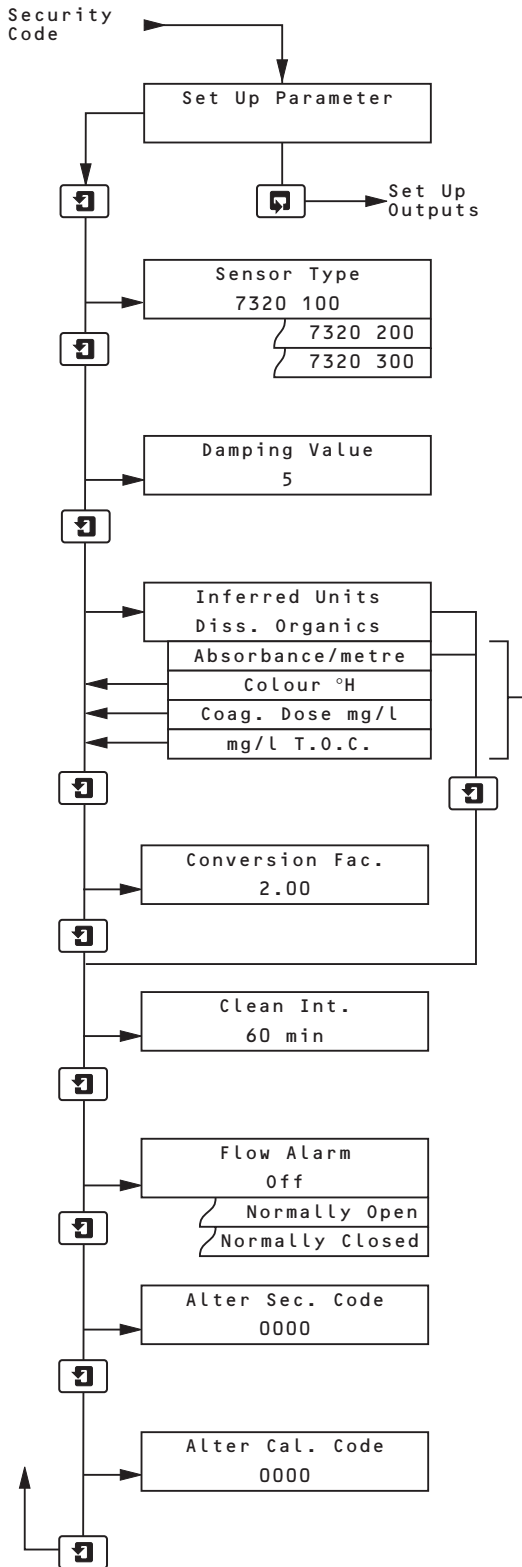

Set Up Parameters Page

Select the appropriate sensor:

- 7320 100 = Low Range Sensor.
- 7320 200 = High Range Sensor.
- 7320 300 = Coagulation Dose Sensor.

When changed P l e a s e W a i t is displayed for 20 seconds.

Enter a damping value in the range 1 to 20.

This is used to prevent short term variations in reading, typically due to bubbles in the sample. Always use the **lowest** value which gives an acceptably stable reading.

Dissolved Organics mode

Inferred Units mode

See Appendix.

Enter the conversion factor between Dissolved Organics and the Inferred Unit selection.



Note. Absorbance/metre has a fixed factor of 1.5.

Cleaning Interval

Enter required interval between automatic cleaning procedures.
Options: 15, 30, 45 & 60 minutes. 2, 4, 6, 12 & 24 hours.

Flow Alarm Input Configuration

Set the normal 'none' alarm condition (normally open or closed), or disable by setting to O f f.

Alter Set Up Parameter Security Code

Enter value in the range 0000 to 9999.

Alter Calibration Security Code

Enter value in the range 0000 to 9999.

Return to top of **Set Up Parameters Page**.

...5 PROGRAMMING

5.6 Set Up Outputs

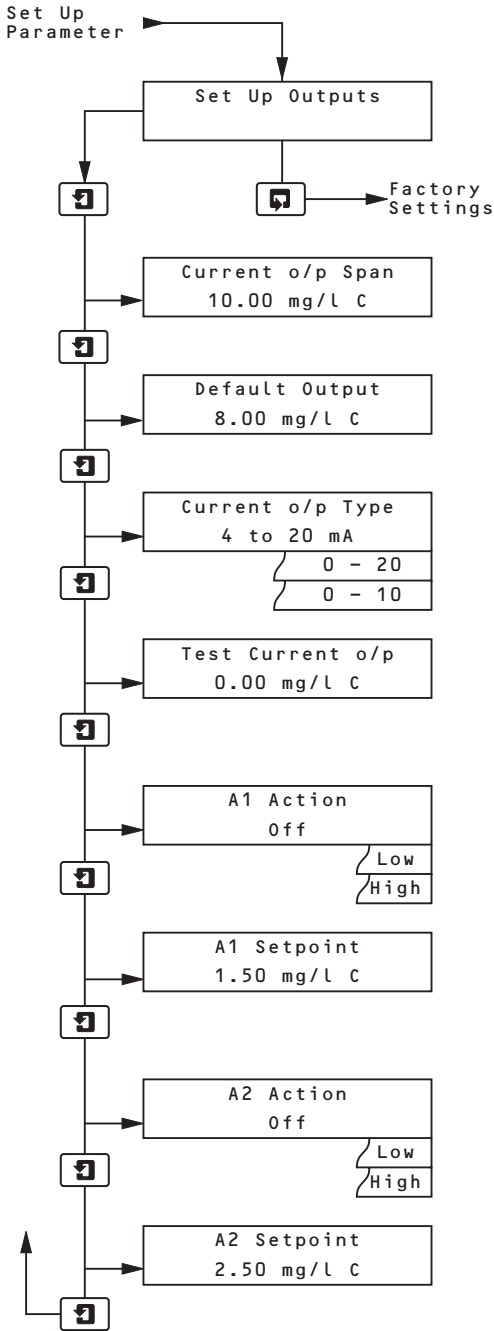

Set Up Outputs Page

Set the current output span between the following limits:

Low range sensor: 0 to 2 and 0 to 20 mg/l C

High range sensor: 0 to 20 and 0 to 100 mg/l C

Set the current output to a default in the event of a diagnostic alarm.

Select the current output:

4 to 20 mA

0 to 20 mA

0 to 10 mA

Set the value within the current o/p span.

The instrument automatically transmits a test signal to represent the current output range.

Alarm 1 Action

This can be set as a high or low alarm contact.

Select **H i g h** or **L o w** as appropriate.

Select **O f f** to disable this alarm.

Adjust setpoint to a value within the range of the sensor.

Alarm 2 Action

This can be set as a high or low alarm contact.

Select **H i g h** or **L o w** as appropriate.

Select **O f f** to disable this alarm.

Adjust setpoint to a value within the range of the sensor.

Return to top of **Set Up Outputs Page**.

5.7 Factory Settings

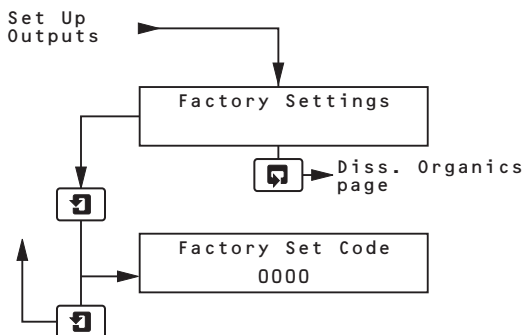

These parameters are set at the factory and will not normally require adjustment on site. However, if the receiver/emitter modules have been changed then the emitter light will need setting. The full **Factory Settings** page is given in Section 6.4.

6 MAINTENANCE

6.1 Standard Solutions

Because UV absorption is a non-specific, aggregate measurement of organic carbon concentration, true standards are not available. In this situation it is convenient to use a standard solution made from a single known organic compound. The monitor then produces readings in units of mg/l of carbon (mgC/l) defined against the calibration standard. Potassium hydrogen phthalate is the recommended standard but other suitably pure, soluble and stable organic compounds could be used instead. If, as is to be expected, an alternative standard solution absorbs more or less strongly at 254 nm than the recommended solution, then different monitor readings will be obtained on a given sample.

The monitor does not require frequent calibration but, when calibrating, particular care must be taken to avoid contamination of standard solutions, particularly the zero standard, with organic material which may be present inside the flowcell.

6.1.1 Zero Standard

Calibration is performed using carbon-free de-ionized water. The practicality of obtaining water which is truly carbon-free is questionable so, as zero is the more important calibration point, it is necessary to use the best quality water available and to ensure that it is not subsequently contaminated by organic matter. In some cases distilled water, while less chemically pure, may contain less organic carbon than de-ionized water.

The zero standard solution should be as fresh as possible but, if storage is unavoidable, a glass container should be used to avoid possible contamination due to leaching of chemicals from a plastic bottle.

6.1.2 Span Standard

Prepared from potassium hydrogen phthalate ($\text{KOOCC}_6\text{H}_4\text{COOH}$, carbon content = 47.05%), Analytical Reagent grade, and high quality de-ionized or distilled water.

To prepare a 1000 mgC/l carbon stock standard solution: dissolve 2.125 (± 0.005) g of potassium hydrogen phthalate, previously dried at 120 °C for 2 hours, in about 500 ml de-ionized water and make up to 1 litre in a volumetric flask. This solution may be stored in a glass bottle in a refrigerator, without freezing, for up to 3 months.

Working standard solutions for monitor calibration should be freshly prepared from the stock standard when required. Dilute the stock solution with high quality de-ionized or distilled water; the standard solution should be discarded after use.

Low Range, 10 mgC/l:

Dilute 10 ml of the stock standard solution to 1 litre in a volumetric flask.

High Range, 40 mgC/l:

Dilute 40 ml of the stock standard solution to 1 litre in a volumetric flask.

6.1.3 Calibration Checks

The system uses an optical system with very stable electronics which avoids the risk of electronic drift. Therefore, routine calibration is normally unnecessary. However, it may be necessary to routinely check the system accuracy (particularly after cleaning). This should then be considered as a calibration check and not a calibration adjustment.

The calibration check can be simply carried out by filling the flowcell with the Zero and Span Standards and observing the readings on the Operating Display Page.

The solutions are poured in from the top of the flowcell.

High Range Sensors:

Remove filler plug on top of the flowcell and use the funnel provided.

Low Range Sensor:

Remove the Cleaner Module, fill flowcell and fit Cleaner Module.

6.2 Scheduled Servicing



Warning. Do NOT open the emitter unit as it uses high voltages which could cause serious injury or death.



Caution. Both emitter and receiver units contain no user serviceable parts and are sealed in clean air conditions at the factory. Opening them could lead to degraded performance. See also the warning above.

The following servicing schedule has been produced as a general guide only. Because the systems are designed for a wide range of applications, where the nature of the sample can vary considerably, it may be necessary to amend the schedule to suit the particular installation and sample conditions.

6.2.1 Cleaning the Flowcell

The required automatic cleaning frequency of the flow chamber and optical windows can only be determined by plant experience. It is recommended that checks are made at appropriate intervals.

Routine servicing is limited to manually cleaning out the flowcell to remove any fouling or sediment which has accumulated over a lengthy period. In particular, if there is a need to calibrate the instrument it is important that no contamination occurs when setting the zero condition. To clean out the high range sensor the cell it must be 'split'. Four stainless steel screws hold it together, but two of them provide a jacking action when unscrewed, thus affording a controlled splitting operation. See Section 6.2.3, Fig. 6.2, for details.

...6 MAINTENANCE

6.2.2 Dismantling the Flowcell for Cleaning and Wiper Maintenance – Figs 6.1 and 6.2

Caution. The emitter and receiver modules contain precision optical components and must be handled accordingly. In particular, the emitter contains all of the power supply, voltage control and lamp components and is quite heavy. Do not support on the wires entering the enclosure.
Always switch off the power to the instrument before starting any service work.

Warning. This instrument uses a high intensity light source which emits UV radiation and must NOT be viewed with the naked eye. Under normal operating conditions it is not possible to see the light source, but if the sensor is dismantled with the power applied, it may be possible to expose the eyes to the strobe flash.

★ Important Notes.

- Ensure that O-rings are removed with the screw collars; it is possible for these seals to be left inside the flowcell.
- During the cleaning procedure, support the modules to remove any strain from the cables.
- Either grub screw pins or pegs ensure that the modules locate in only one position.
- The emitter module is heavier than the receiver, so extra support is needed.

Caution. Care must be taken while handling the emitter module and, for safety reasons, it must NEVER be operated while outside the measurement cell.

- ① Perform a manual clean (see Section 5.2) to ensure that the wiper blade is in the 'parked' position.

Caution. Unscrew the collar and carefully withdraw the module.

Caution. Unscrew the collar and carefully withdraw the module.

- ⑤ Clean the inside of the flow chamber and other assemblies thoroughly using mild detergent and rinse with de-ionized water.

- ⑥ Inspect the wiper blade for wear or damage and fit a new one if necessary, ensuring that it is fitted in the 'parked' position.

- ⑦ Reassemble emitter and receiver modules using new seals ensuring that the modules locate in the keyways before tightening the collars.

Caution.

Do not force the modules out as damage to the keyways will cause alignment difficulties.

If, after unscrewing the collars the modules appear jammed, try slackening the grub screw pins – see lower illustration for positions.

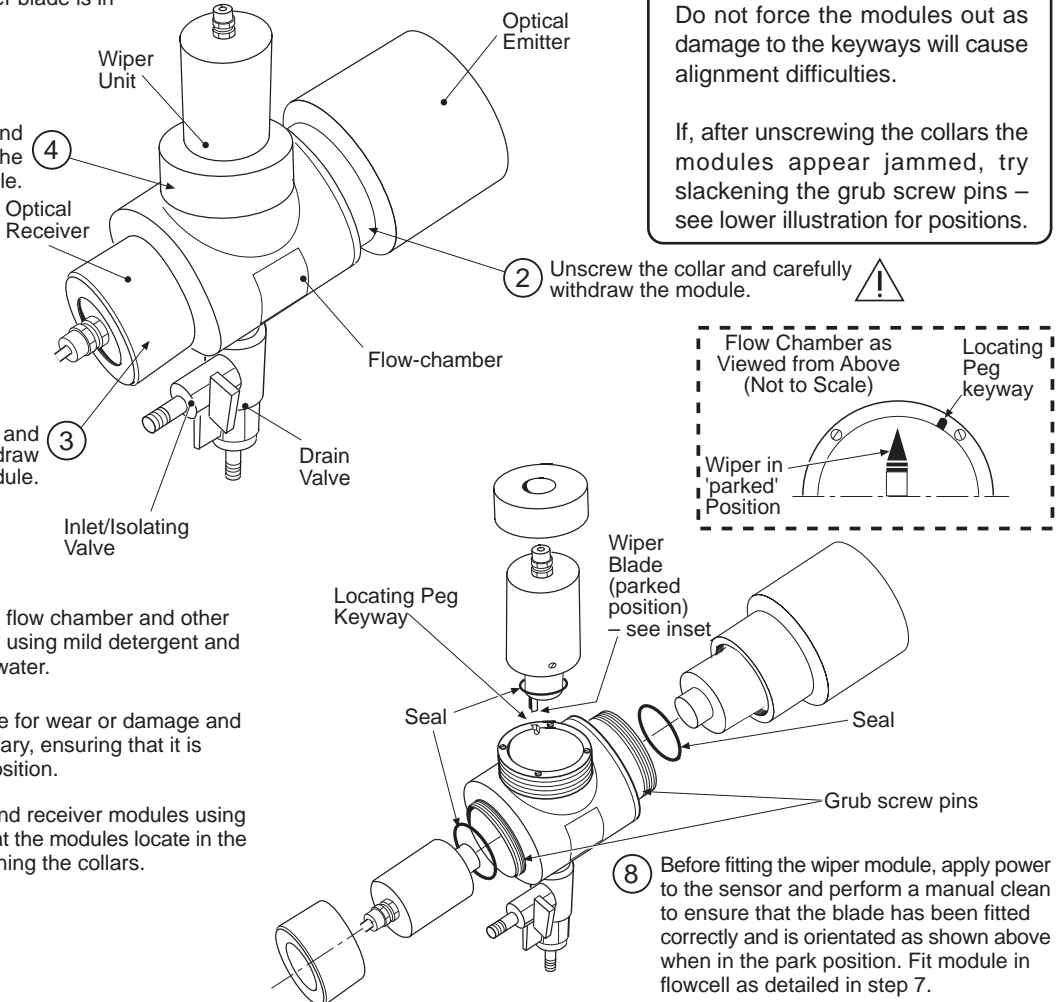
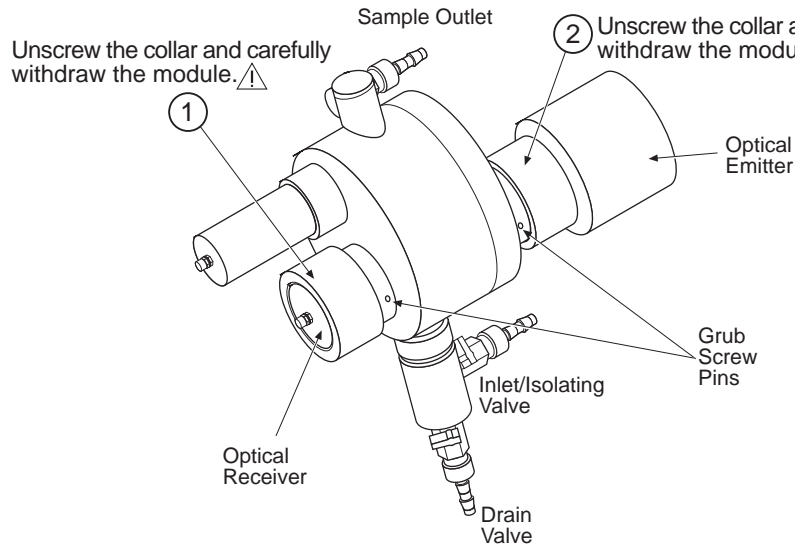

Fig. 6.1 Low Range Sensor – Dismantling the Flowcell for Cleaning



Caution.
Do not force the modules out as damage to the keyways will cause alignment difficulties.

If, after unscrewing the collars, the modules appear jammed try slackening the grub screw pins.

- 3 Split the flowcell to access the flow chamber – see Fig. 6.3 for procedure.

- 4 Clean the inside of the flow chamber and other assemblies thoroughly.

Use mild detergent and rinse with de-ionized water.

Inspect the wiper blades for wear or damage and fit new ones if necessary – see Fig. 6.4 for assembly details.

- 5 Reassemble flowcell using new seals.

Ensure that the modules locate in the keyways before tightening the collars.

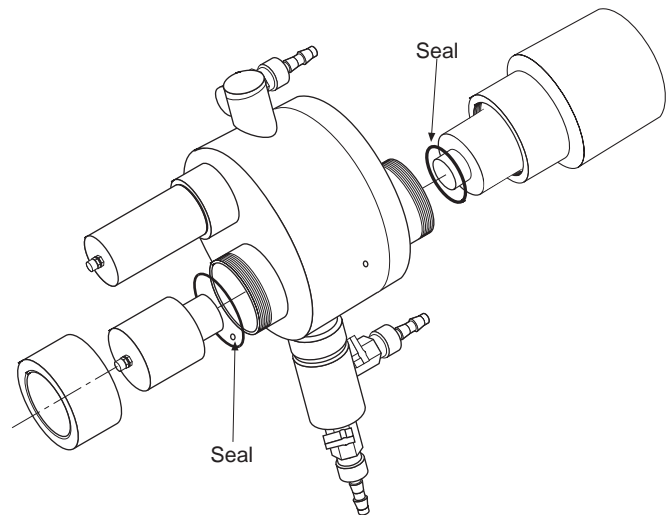
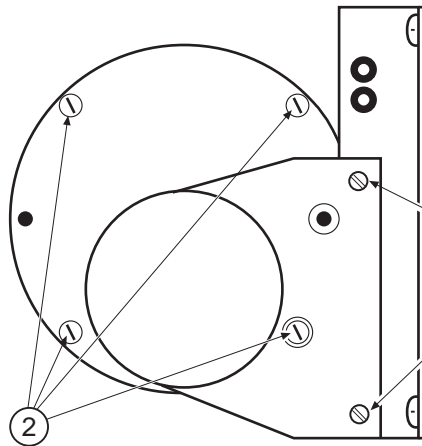

Fig. 6.2 High Range Sensors – Cleaning the Flowcell

View from emitter end



1 Remove the securing screws to free the mounting plate from the angle bracket (2).

Remove the four stainless steel closing screws holding the flowcell halves together.

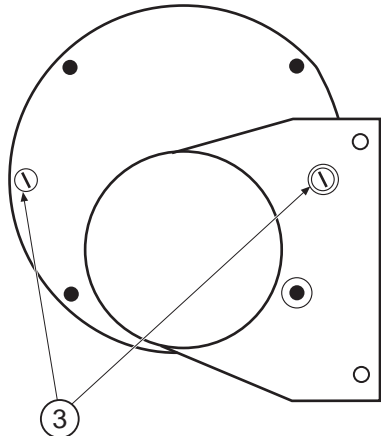

4 Thoroughly check and clean the inside of the cell. The wiper blades can also be serviced/changed – see Fig. 6.4.

3 Thread two of the stainless steel screws into holes provided and advance them slowly and evenly to push the cell halves apart. When the O-ring seal is clear of the body the cell halves should separate easily.

5 Reassemble.

Fig. 6.3 Splitting the High Range Flowcell

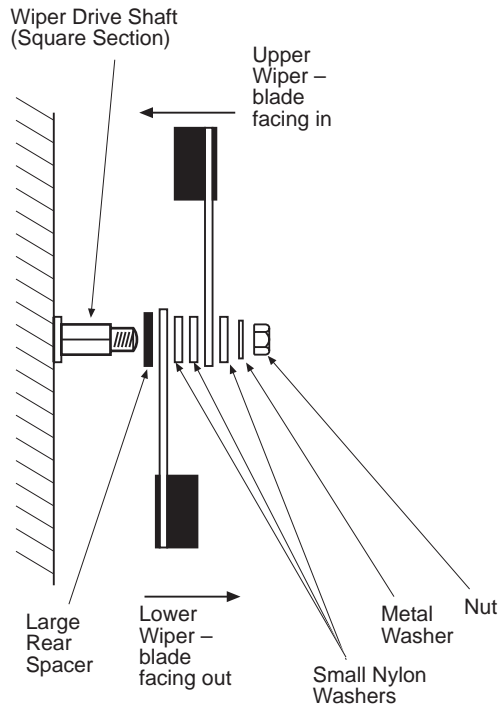

★ **Note.** The proper functioning of the wiper system depends on the correct assembly of the washers and orientation of the wiper blades.

- ① Remove the wiper blades securing nut.
- ② Remove the blades and washers from the drive shaft.
- ③ Before reassembling the components on the drive shaft, perform a Manual Clean (section 5.2) to 'park' the blades.
- ④ Reassemble the components on the drive shaft in the order shown and tighten the nut. Also ensure that the blades are in the parked position, i.e. horizontal.
- ⑤ Perform another Manual Clean (section 5.2) to 'park' the blades as a final check.

Wipers in the Parked Position

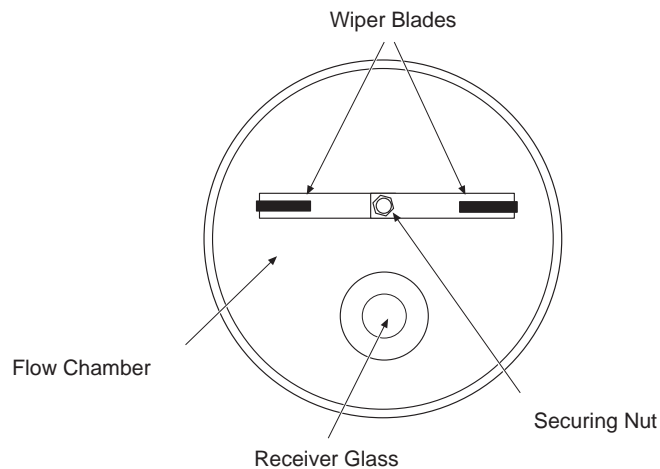

Fig. 6.4 Servicing the High Range Wipers

...6 MAINTENANCE

6.3 Unscheduled Servicing

6.3.1 Monitor Diagnostic Information

The software incorporates diagnostic facilities which provide information on the status of the instrument (lower line of the Program Parameters display) in the Operating Display Page. All diagnostic messages result in de-energising the 'Out of Service' relay with the exception of the 'Out of Range' condition.

Due to the fail-safe operation of the relay, an alarm condition is generated in the event of a loss of mains supply.

Display Message	Cause	Action
Flashing numeric display	Measured value higher than the full scale value of the sensor.	None.
Alarm One/Two	Either Alarm 1 or 2 is in the alarm state.	None.
Lamp Disabled	The flowcell light source has been manually disabled in the Operating Display Page.	See Section 5.2.
Flow Failure	Loss of sample/flow pressure detected by the external sample switch contact.	Re-instate sample.
Loss of Signal	No signal received from the two receivers. Possible causes: a) Flowcell requires cleaning. b) Failure of the automatic cleaner. c) Faulty connections between sensor and transmitter. d) Failure of lamp power supply. e) Failure of either the emitter or receiver.	Dismantle flowcell – see Section 6.2.2. Dismantle flowcell to reveal wiper – see Section 6.2.3 – and check operation of cleaner by performing a manual clean – see Section 5.2. Check sensor connections in the transmitter – see Section 3.3. Suspect an electronic malfunction*. Suspect an electronic malfunction*.
No Reply- Timeout	There is a hardware problem between the internal circuit boards.	Suspect an electronic malfunction*.
Conversion Error	There is a hardware communication problem regarding signal interrogation.	Suspect an electronic malfunction*.
Bad Data	There is a hardware communication problem regarding signal interrogation.	Suspect an electronic malfunction*.

*These conditions indicate an internal electronic malfunction which cannot be rectified by other than ABB personnel.

Table 6.1 Diagnostic Information

6.3.2 Unstable or Erratic Readings

This is usually caused by air bubbles entrained in the sample and is usually more pronounced on the low level sensor due to its greater sensitivity. These bubbles are usually as a result of degassing of the sample caused by a drop in sample pressure, or a rise in temperature. Cleaning the optical windows and increasing the flow through the flowcell usually overcomes the problem. If severe, it is recommended that a de-bubbler unit is installed – see Section 2.4.

6.4 Replacing the Emitter and Receiver Modules

Having replaced the emitter/receiver module(s) (procedure in Section 6.4.1) it will be necessary to adjust the emitter brightness (procedure in Section 6.4.2).

Please observe all **Warnings, Cautions** and **Notes** in Section 6.2.2.

6.4.1 Changing the Modules

- 1) Electrically isolate the equipment.
- 2) Disconnect the receiver and/or emitter wires at the receiver/emitter.
- 3) Follow the procedures in Fig. 6.1 (Low Ranger Sensor) and/or Fig. 6.2 (High Range Sensor) for removing the modules.
- 4) Check that the 'O' ring is fitted to the new emitter/receiver.
- 5) Insert the emitter/receiver modules into the flowcell; rotate them to align with internal keys before tightening the collars.
- 6) Connect the appropriate wires the emitter/receiver (see Fig. 3.3).
- 7) Switch on the mains supply and allow the instrument to warm up for five minutes.

6.4.2 Adjusting the Emitter Brightness

- 1) Fill the flowcell with high purity water.
- 2) Enter the Factory Programming Page (see overpage) using the security code 73. If this has been changed at any time, use 7300.
- 3) Scroll to **Interrogate Display**.
- 4) Remove the small plug on the left hand side of the emitter. Inside is a multi-turn potentiometer which may be adjusted using a small bladed screwdriver.
- 5) Bearing in mind that the display updates every six seconds, adjust the brightness control so that a **Signal Total Value** of '3900' \pm 1000 is displayed.
- 6) Check that the two **Peak** values are between 50 and 62; otherwise contact Stonehouse.
- 7) When adjusted correctly, fit the plug into the body of the receiver.
- 8) Carry out a calibration (see Section 5.3).
- 9) Return the instrument to normal operation (see Section 5.2).

...6 MAINTENANCE

Set Up
Outputs

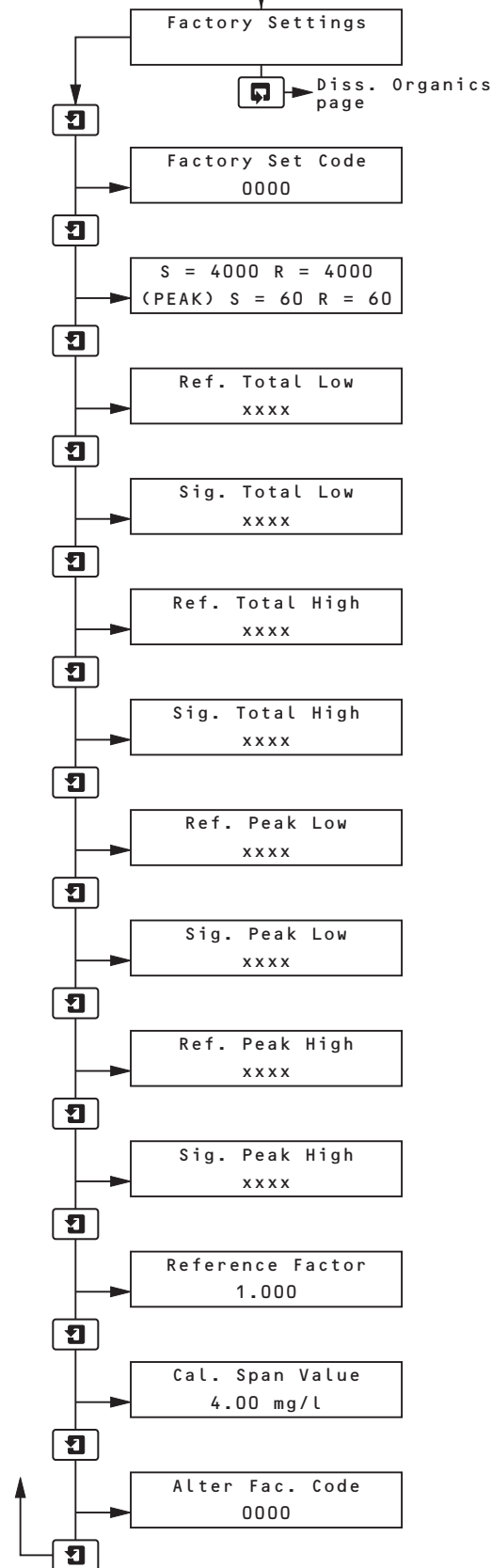

Factory Settings

These parameters are set at the factory and will not need further adjustment on site. Access must only be undertaken by nominated personnel.

Secure Factory Settings Access

Enter the required security code (between 0000 and 9999). Access will be denied if an incorrect value is entered.

Displays the raw signals from the sensor.

S = UV254 Signal, R = IR880 Reference Signal.

This value is updated after a sensor calibration and is for diagnostic purposes only.

This value is updated after a sensor calibration and is for diagnostic purposes only.

This value is updated after a sensor calibration and is for diagnostic purposes only.

This value is updated after a sensor calibration and is for diagnostic purposes only.

This value is updated after a sensor calibration and is for diagnostic purposes only.

This value is updated after a sensor calibration and is for diagnostic purposes only.

This value is updated after a sensor calibration and is for diagnostic purposes only.

This value is updated after a sensor calibration and is for diagnostic purposes only.

Enables the reference compensation factor to be changed to suit a particular application. Range 0.000 to 9.000.

Enter value of the span calibration solution.

After 'Factory Setting' security code enter value in the range 0000 to 9999.

Note.

To reset factory default settings:

- 1) Switch off the instrument.
- 2) Switch on again with the down arrow switch pressed.

7 SPECIFICATION

Overall Specification

Range (based on potassium hydrogen phthalate calibration standards):

7320 100 (low range) 0 to 20 mg/l.

7320 200 (high range) 0 to 100 mg/l.

7320 300 (coagulate dose) 0 to 100 mg/l.

Inferred Units

Absorbance Units/metre

Colour °H

Coag. Dose mg/l

mg/l T.O.C.

Maximum current output

scale expansion:

Low range: 0 to 2 mg/l C

High range: 0 to 20 mg/l C

Display Resolution:

Low range: 0.01 mg/l.

High range: 0.1 mg/l.

Reproducibility: $\pm 3\%$ of reading.

Response time: Normally three minutes for 90% step change depending on signal damping factor.

Sample flow-rate: 0.5 to 5 l/min (free of air bubbles). A higher minimum flow-rate is required at high turbidity levels when using the high range sensor.

Sample temperature: 0 to 40 °C.

Sample pressure: 3 bar maximum.

Lamp life: Up to 10 years.

Display:

Measured value: 4-digit backlit LCD window.

Information: 2 x 16-character dot matrix, backlit LCD window.

Current output: 0 to 10, 0 to 20 and 4 to 20 mA.

Maximum load

resistance: 750 ohms.

Accuracy: $\pm 0.25\%$ of FSD or $\pm 0.5\%$ of reading.

Diagnostics: Out of sample.
Lamp disabled.
Loss of signal.
Electronic failure.

Set points and relays:

Number of setpoints: Programmable over the instrument range.

Relay contacts: single pole changeover.

Diagnostic relay: Out of service, single pole/single contact.

Rating: 250 V a.c., 5 A maximum noninductive.

Internal wiper cleaning

system: Programmable operation frequency 15, 30, 45 & 60 minutes. 2, 4, 6, 12 & 24 hours.

Power supply: 100 to 130 V a.c. and 200 to 260 V a.c., 50 to 60 Hz.

Power consumption: Less than 15 W.

Environmental data:

Operating temperature: 0 to 40 °C.

Protection: IP65 enclosure.

Operating humidity: Up to 95% non-condensing.

Maximum distance between

transmitter and sensor: 200 mm to 750 mm

Overall dimensions:

Transmitter: 252 mm wide
453 mm high
133 mm deep

Sensors:

Low range: 327 mm wide
410 mm high

High range: 408 mm wide
373 mm high
191 mm deep

Weight (ex packing):

Transmitter: 11 kg

Sensor: 6 Kg

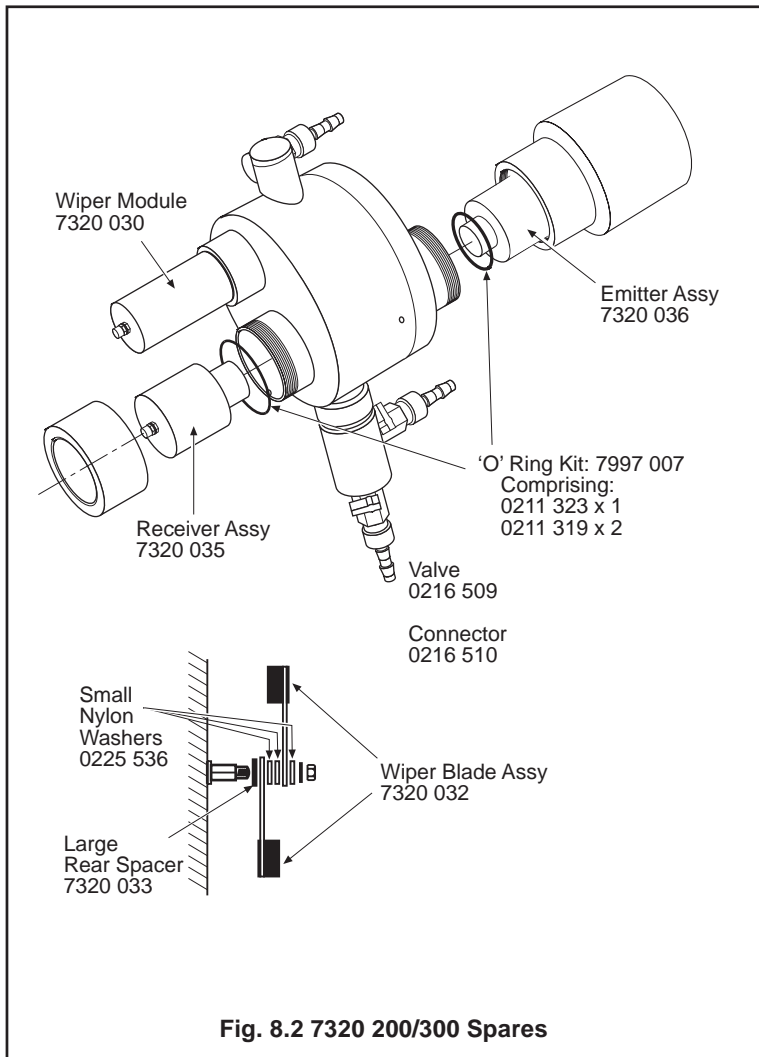
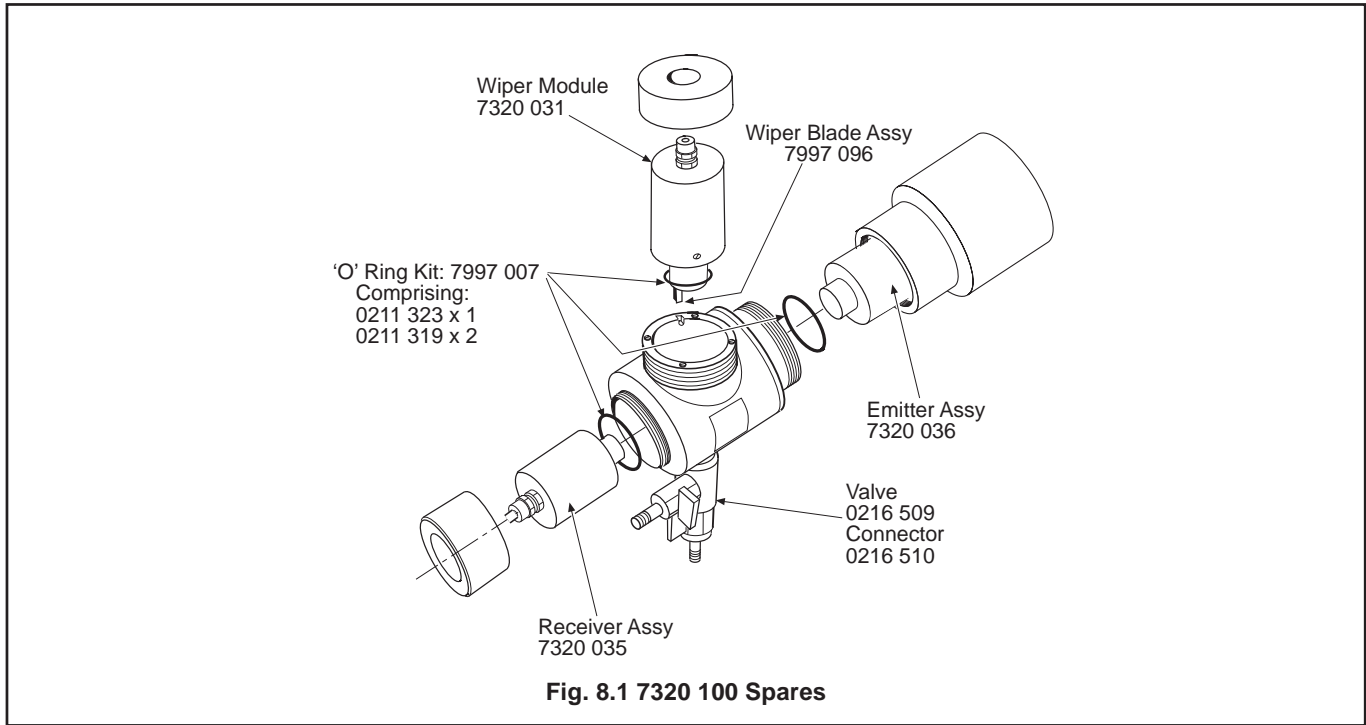

7320 Transmitter

Transmitter Item	ABB Part No
Motherboard	7320 040
Software EPROM	7320 041
Display/Keypad board	7320 043
Sampling board	7320 044
Current output board	7320 045
Alarm board	7320 046
12 v PSU assy (main electronics)	7320 047
24 v PSU assy (emitter supply)	7320 048

Fig. 8.3 Transmitter Spares

A.1 Inferred Units

In normal mode of operation the instrument is calibrated in mg/l dissolved organic carbon. However, the monitor can be configured to display values in one of four inferred units. The value is calculated by the instrument using a conversion factor shown below.

Unit	Factor
Absorbance Units/metre	Fixed at 1.5
Colour (°H)	Variable 0.10 to 9.00
Coagulant Dose (mg/l)	Variable 0.10 to 9.00
T.O.C. (mg/l)	Variable 0.10 to 9.00

With the exception of 1, the conversion factor needs to be determined by laboratory analysis of the actual sample and it assumes that the factor is constant.

When using these inferred units it must always be remembered that the instrument only measures absorbance of dissolved organics at 254 nm. Therefore, if the conversion factor changes, the instrument readings may not agree with independent laboratory results until a new conversion factor is entered.

***** **Note.** When the above inferred units are selected, the alarm settings, current output range and the calibration solution values remain in mg/l dissolved organics.

NOTES

PRODUCTS & CUSTOMER SUPPORT

Products

Automation Systems

- *for the following industries:*
 - Chemical & Pharmaceutical
 - Food & Beverage
 - Manufacturing
 - Metals and Minerals
 - Oil, Gas & Petrochemical
 - Pulp and Paper

Drives and Motors

- *AC and DC Drives, AC and DC Machines, AC motors to 1kV*
- *Drive systems*
- *Force Measurement*
- *Servo Drives*

Controllers & Recorders

- *Single and Multi-loop Controllers*
- *Circular Chart, Strip Chart and Paperless Recorders*
- *Paperless Recorders*
- *Process Indicators*

Flexible Automation

- *Industrial Robots and Robot Systems*

Flow Measurement

- *Electromagnetic Magnetic Flowmeters*
- *Mass Flow Meters*
- *Turbine Flowmeters*
- *Wedge Flow Elements*

Marine Systems & Turbochargers

- *Electrical Systems*
- *Marine Equipment*
- *Offshore Retrofit and Referredishment*

Process Analytics

- *Process Gas Analysis*
- *Systems Integration*

Transmitters

- *Pressure*
- *Temperature*
- *Level*
- *Interface Modules*

Valves, Actuators and Positioners

- *Control Valves*
- *Actuators*
- *Positioners*

Water, Gas & Industrial Analytics Instrumentation

- *pH, conductivity, and dissolved oxygen transmitters and sensors*
- *ammonia, nitrate, phosphate, silica, sodium, chloride, fluoride, dissolved oxygen and hydrazine analyzers.*
- *Zirconia oxygen analyzers, katharometers, hydrogen purity and purge-gas monitors, thermal conductivity.*

Customer Support

ABB Automation provides a comprehensive after sales service via a Worldwide Service Organization. Contact one of the following offices for details on your nearest Service and Repair Centre.

United Kingdom

ABB Automation Ltd
Tel: +44 (0)1453-826-661
Fax: +44 (0)1453-827-856

United States of America

ABB Automation Inc.
Instrumentation Division
Tel: +1 215-674-6000
Fax: +1 215-674-7183

Client Warranty

Prior to installation, the equipment referred to in this manual must be stored in a clean, dry environment, in accordance with the Company's published specification. Periodic checks must be made on the equipment's condition.

In the event of a failure under warranty, the following documentation must be provided as substantiation:

1. A listing evidencing process operation and alarm logs at time of failure.
2. Copies of operating and maintenance records relating to the alleged faulty unit.



The Company's policy is one of continuous product improvement and the right is reserved to modify the information contained herein without notice.

© ABB 2001

Printed in UK (11.01)

ABB Automation Ltd
Oldends Lane, Stonehouse
Gloucestershire, GL10 3TA
UK
Tel: +44 (0)1453-826-661
Fax: +44 (0)1453-827-856

ABB Automation Inc.
125 E. County Line Road
Warminster, PA 18974
USA
Tel: +1 215-674-6000
Fax: +1 215-674-7183

ABB has Sales & Customer Support expertise
in over 100 countries worldwide

www.abb.com