

Motor Protection Relay REM610

Technical Reference Manual - ANSI Version



Contents

Copyrights	7
1. Introduction.....	9
1.1. This manual.....	9
1.2. Use of symbols	9
1.3. Intended audience	10
1.4. Product documentation	10
1.5. Document conventions	10
1.6. Document revisions.....	11
2. Safety information.....	13
3. Product overview	15
3.1. Use of the relay.....	15
3.2. Features.....	15
4. Application	17
4.1. Requirements.....	17
4.2. Configuration	17
5. Technical description	21
5.1. Functional description.....	21
5.1.1. Product functions.....	21
5.1.1.1. Protection functions	21
5.1.1.2. Inputs.....	21
5.1.1.3. Outputs.....	22
5.1.1.4. Emergency start.....	22
5.1.1.5. Restart disable.....	22
5.1.1.6. Motor start up	23
5.1.1.7. Rated current of the protected unit ...	23
5.1.1.8. Disturbance recorder.....	24
5.1.1.9. Front panel.....	24
5.1.1.10. Non-volatile memory	25
5.1.1.11. Self-supervision.....	25
5.1.1.12. Time synchronization	26
5.1.2. Measurements	27
5.1.3. Configuration.....	28
5.1.4. Protection.....	31
5.1.4.1. Block diagram.....	31
5.1.4.2. Thermal overload protection	32
5.1.4.3. Start-up supervision	37
5.1.4.4. Short-circuit protection.....	39
5.1.4.5. Undercurrent protection	40
5.1.4.6. Ground-fault protection	41
5.1.4.7. Unbalance protection	42

- 5.1.4.8. Phase reversal protection 43
- 5.1.4.9. Cumulative start-up time counter..... 43
- 5.1.4.10. Circuit-breaker failure protection..... 44
- 5.1.4.11. Temperature protection (optional) 45
- 5.1.4.12. Settings 49
- 5.1.4.13. Technical data on protection functions 60
- 5.1.5. Trip-circuit supervision 64
- 5.1.6. Target LEDs and operation target messages 66
- 5.1.7. Motor running time counter..... 66
- 5.1.8. Demand values 66
- 5.1.9. Commissioning tests 67
- 5.1.10. Disturbance recorder 67
 - 5.1.10.1. Function..... 67
 - 5.1.10.2. Disturbance recorder data..... 68
 - 5.1.10.3. Control and target of disturbance recorder status..... 69
 - 5.1.10.4. Triggering..... 69
 - 5.1.10.5. Settings and unloading 69
 - 5.1.10.6. Event code of the disturbance recorder 70
- 5.1.11. Recorded data of the last events 70
- 5.1.12. Communication ports..... 72
- 5.1.13. IEC 60870-5-103 remote communication protocol..... 73
- 5.1.14. Modbus remote communication protocol 76
 - 5.1.14.1. Profile of Modbus 77
- 5.1.15. SPA bus communication protocol parameters ... 91
 - 5.1.15.1. Event codes 105
- 5.1.16. Self-supervision (IRF) system 109
 - 5.1.16.1. Self-supervision of the RTD module.. 111
- 5.1.17. Relay parameterization 111
- 5.2. Design description 112
 - 5.2.1. Input/output connections 112
 - 5.2.2. Serial communication connections 117
 - 5.2.3. Technical data 121
- 6. Application examples 127**
 - 6.1. Setting calculations 127
 - 6.1.1. Protected unit scaling factor..... 127
 - 6.1.2. Thermal overload protection 127
 - 6.1.2.1. Selecting weighting factor p 128
 - 6.1.2.2. Safe stall time for hot starts..... 130
 - 6.1.2.3. Checking the set safe stall time for cold starts 135

- 6.1.2.4. Checking the set safe stall time for a single start..... 135
- 6.1.2.5. Restart disable level, 49 RESTDIS .. 135
- 6.1.2.6. Prior alarm level, 49 ALARM 135
- 6.1.2.7. Time constant dial, Kc..... 136
- 6.1.3. Start-up supervision 136
 - 6.1.3.1. Start-up supervision based on thermal stress calculation..... 136
 - 6.1.3.2. Checking the need for speed switch.. 136
- 6.1.4. Cumulative start-up time counter 137
- 6.1.5. Short-circuit protection 137
- 6.1.6. Unbalance and phase reversal protection 138
 - 6.1.6.1. Selecting the pickup value for element 46 138
 - 6.1.6.2. Selecting the time constant, 46 TDIAL..... 138
 - 6.1.6.3. Connection with two phase current transformers 138
- 6.1.7. Ground-fault protection 139
 - 6.1.7.1. Stabilizing virtual ground-fault currents 140
 - 6.1.7.2. Increasing the sensitivity of the ground-fault protection..... 140
- 6.1.8. Circuit-breaker failure protection 140
- 6.1.9. Temperature protection (optional)..... 140
- 6.2. Protecting a circuit-breaker controlled motor 140
- 6.3. Protecting a motor at an ambient temperature other than 40°C..... 142
- 6.4. Protecting a contactor controlled motor..... 143
- 6.5. Protecting non-rotating objects 144
- 6.6. Ground-fault protection in an isolated or a compensated network..... 144
- 6.7. Ground-fault protection in a solidly grounded network ... 145
- 7. Ordering information 147**
- 8. Check lists 149**
- 9. Abbreviations 157**

Copyrights

The information in this document is subject to change without notice and should not be construed as a commitment by ABB Oy. ABB Oy assumes no responsibility for any errors that may appear in this document.

In no event shall ABB Oy be liable for direct, indirect, special, incidental or consequential damages of any nature or kind arising from the use of this document, nor shall ABB Oy be liable for incidental or consequential damages arising from the use of any software or hardware described in this document.

This document and parts thereof must not be reproduced or copied without written permission from ABB Oy, and the contents thereof must not be imparted to a third party nor used for any unauthorized purpose.

The software or hardware described in this document is furnished under a license and may be used, copied or disclosed only in accordance with the terms of such license.

© Copyright 2011 ABB Oy

All rights reserved.

Trademarks

ABB is a registered trademark of ABB Group. All other brand or product names mentioned in this document may be trademarks or registered trademarks of their respective holders.

Warranty

Please inquire about the terms of warranty from your nearest ABB representative.

1. Introduction

1.1. This manual

This manual provides thorough information on the relay REM610 and its applications, focusing on giving a technical description of the relay.

For more information about earlier revisions, refer to Section 1.6. Document revisions.

Refer to the Operator's Manual for instructions on how to use the human-machine interface (HMI) of the relay, also known as the man-machine interface (MMI), and to the Installation Manual for installation of the relay.

1.2. Use of symbols

This publication includes the following icons that point out safety-related conditions or other important information:



The electrical warning icon indicates the presence of a hazard which could result in electrical shock.



The warning icon indicates the presence of a hazard which could result in personal injury.



The caution icon indicates important information or warning related to the concept discussed in the text. It might indicate the presence of a hazard which could result in corruption of software or damage to equipment or property.



The information icon alerts the reader to relevant facts and conditions.



The tip icon indicates advice on, for example, how to design your project or how to use a certain function.

Although warning hazards are related to personal injury, it should be understood that operation of damaged equipment could, under certain operational conditions, result in degraded process performance leading to personal injury or death. Therefore, comply fully with all warning and caution notices.

1.3. Intended audience

This manual is intended for operators and engineers to support normal use of as well as configuration of the product.

1.4. Product documentation

In addition to the relay and this manual, the delivery contains the following relay-specific documentation:

Table 1.4.-1 REM610 product documentation

Name	Document ID
Installation Manual	1MRS752265-MUM
Technical Reference Manual	1MRS752263-MUM
Operator's Manual	1MRS752264-MUM

1.5. Document conventions

The following conventions are used for the presentation of material:

- Push button navigation in the human-machine interface (HMI) menu structure is presented by using the push button icons, for example:

To navigate between the options, use ▲ and ▼.

- HMI menu paths are presented as follows:

Use the arrow buttons to select CONFIGURATION\ COMMUNICATION\ SPA SETTINGS\ PASSWORD SPA.

- Parameter names, menu names, relay target messages and relay's HMI views are shown in a Courier font, for example:

Use the arrow buttons to monitor other measured values in the menus DEMAND VALUES and HISTORY DATA.

- HMI messages are shown inside quotation marks when it is good to point out them for the user, for example:

When you store a new password, the relay confirms the storage by flashing “- - -” once on the display.

1.6.**Document revisions**

Version	IED Revision	Date	History
A	B	25.11.2003	Document created. Modified for ANSI compliance from the IEC version B.
B	C	01.10.2007	Content updated according to the IEC version D.
C	C	12.12.2007	Added information related to ordering parts and accessories.
D	C	22.05.2009	Content updated
E	C	18.11.2011	Language sets updated.

2. Safety information



Dangerous voltages can occur on the connectors, even though the auxiliary voltage has been disconnected.

Non-observance can result in death, personal injury or substantial property damage.

Only a competent electrician is allowed to carry out the electrical installation.

National and local electrical safety regulations must always be followed.

The frame of the device has to be carefully grounded.

When the plug-in unit has been detached from the case, do not touch the inside of the case. The relay case internals may contain high voltage potential and touching these may cause personal injury.



The device contains components which are sensitive to electrostatic discharge. Unnecessary touching of electronic components must therefore be avoided.

Breaking the sealing tape on the upper handle of the device will result in loss of guarantee and proper operation will no longer be insured.

3. Product overview

3.1. Use of the relay

The motor protection relay REM610 is a versatile multifunction protection relay mainly designed to protect motors in a wide range of motor applications.

The relay is based on a microprocessor environment. A self-supervision system continuously monitors the operation of the relay.

The HMI includes a liquid crystal display (LCD) which makes the local use of the relay safe and easy.

Local control of the relay via serial communication can be carried out with a computer connected to the front communication port. Remote control can be carried out via the rear connector connected to the control and monitoring system through the serial communication bus.

3.2. Features

- Three-phase motor start-up supervision based on thermal stress calculation with speed switch blocking ability
- Three-phase overcurrent protection with definite-time characteristic and speed switch blocking ability
- Three-phase short-circuit protection with instantaneous or definite-time characteristic
- Three-phase undercurrent (loss of load) protection with definite-time characteristic
- Non-directional ground-fault protection with definite-time characteristic.
- Three-phase thermal overload protection
- Three-phase unbalance protection based on the negative-phase-sequence current with inverse definite minimum time characteristic
- Phase reversal protection based on the negative-phase-sequence current
- Cumulative start-up time counter with restart disable function
- Circuit-breaker failure protection
- Temperature protection elements with definite-time characteristic
- Emergency start function
- Optional RTD module
 - with six measuring inputs
 - supports PTC thermistors and various RTD sensors
 - three additional galvanically isolated digital inputs
- Four accurate current inputs
- Time synchronization via a digital input
- Trip-circuit supervision
- User-selectable rated frequency 50/60 Hz
- Three normally open trip contacts

- Two change-over (form c) non-trip contacts
- Output contact functions freely configurable for wanted operation
- Two galvanically isolated digital inputs and three additional galvanically isolated digital inputs on the optional RTD module
- Disturbance recorder:
 - Recording time up to 80 seconds
 - Triggering by one or several internal or digital input signals
 - Records four analog channels and up to eight user-selectable digital channels
 - Adjustable sampling rate
- Non-volatile memory for:
 - Up to 100 event codes with time stamp
 - Setting values
 - Disturbance recorder data
 - Recorded data of the five last events with time stamp
 - Operation target messages and LEDs showing the status at the moment of power failure
- HMI with an alphanumeric LCD and navigation buttons
 - Eight programmable LEDs
- Multi-language support
- User-selectable password protection for the HMI
- Display of primary current values
- Demand values
- All settings can be modified with a PC
- Optical front communication connection: wirelessly or via cable
- Optional rear communication module with plastic fibre-optic, combined fibre-optic (plastic and glass) or RS-485 connection for system communication using the SPA-bus, IEC 60870-5-103 or Modbus (RTU and ASCII) communication protocol
- Battery back-up for real-time clock
- Battery charge supervision
- Continuous self-supervision of electronics and software
- Detachable plug-in unit

4. Application

REM610 is a versatile multifunction protection relay mainly designed for protection of standard medium and large MV asynchronous motors in a wide range of motor applications. It handles fault conditions during motor start up, normal run, idling and cooling down at standstill in, for example, pump, fan, mill or crusher applications.

The large number of integrated protection functions makes REM610 a complete protection against motor damage. The relay can be used with both circuit-breaker controlled and contactor controlled drives.

REM610 can equally well be used to protect, for instance, feeder cables and power transformers which require thermal overload protection and, for instance, single, two or three-phase overcurrent or non-directional ground-fault protection.

The large number of digital inputs and output contacts allows a wide range of applications.

4.1. Requirements

To secure correct and safe operation of the relay, preventive maintenance is recommended to be performed every five years when the relay is operating under the specified conditions; see Table 4.1.-1 and Section 5.2.3. Technical data.

When being used for real-time clock or recorded data functions, the battery should be changed every five years.

Table 4.1.-1 Environmental conditions

Recommended temperature range (continuous)	-10...+55°C
Limit temperature range (short-term)	-40...+70°C
Temperature influence on the operation accuracy of the protection relay within the specified service temperature range	0.1%/°C
Transport and storage temperature range	-40...+85°C

4.2. Configuration

The appropriate configuration of the output contact matrix enables the use of the signals from the protection elements as contact functions. The pickup signals can be used for blocking co-operating protection relays and signalling.

The Fig. 4.2.-1 and Fig. 4.2.-2 represent REM610 with the default configuration: all trip signals are routed to trip the circuit breaker. In Fig. 4.2.-1 the residual current is measured via a core-balance current transformer and in Fig. 4.2.-2 via a summation connection of the phase current transformers. Fig. 4.2.-3 represents REM610 connected to a contactor controlled motor with the trips routed to trip the contactor via signal relays.

Technical Reference Manual - ANSI Version

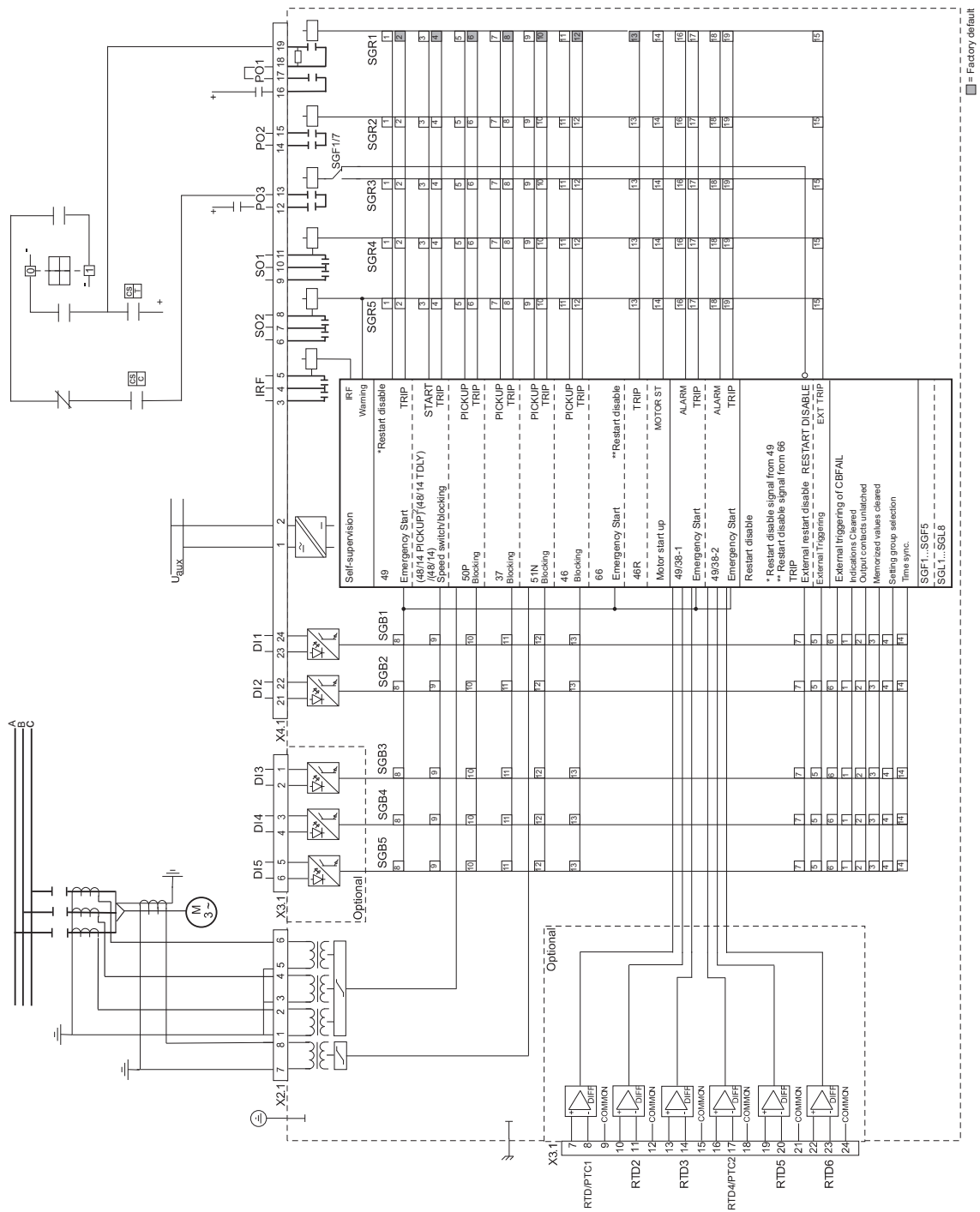

Fig. 4.2.-1 Connection diagram, example 1

A060571

Technical Reference Manual - ANSI Version

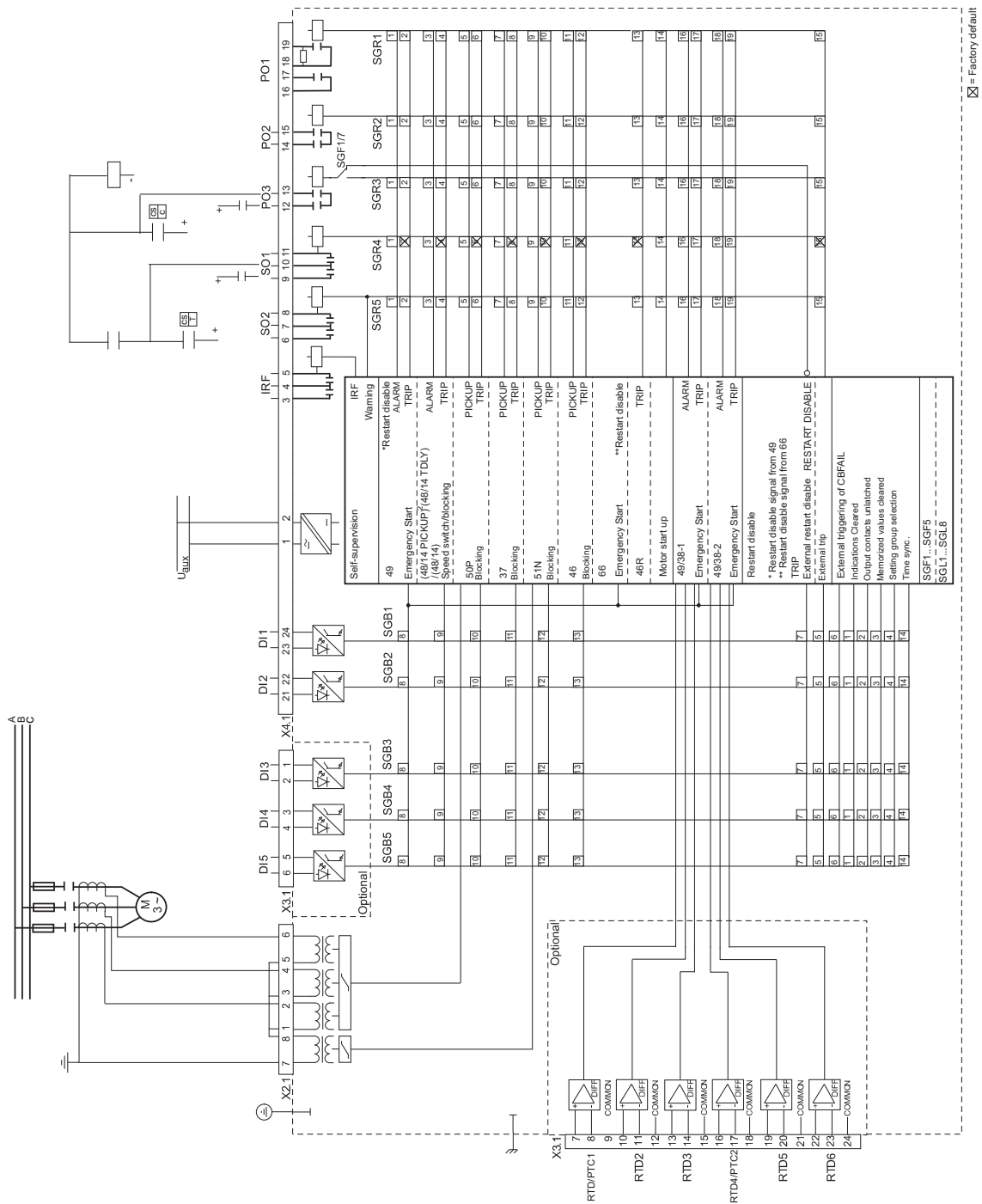

Fig. 4.2.-3 Connection diagram, example 3

A060569

5. Technical description

5.1. Functional description

5.1.1. Product functions

5.1.1.1. Protection functions

Table 5.1.1.1.-1 IEC symbols and IEEE device numbers

Function description	IEC symbol	IEEE Device No.
Three-phase thermal overload protection	$\theta >$	49M
Motor start-up supervision based on thermal stress calculation	$I_s^2 t_s$	48/14
Three-phase definite-time overcurrent protection, low-set element	$I_s >$	51/14
Three-phase instantaneous or definite-time short circuit protection, high-set element	$I >>$	50/51
Inverse-time unbalance protection based on negative-phase-sequence current	$I_2 >$	46
Phase reversal protection	REV	46R
Definite-time undercurrent (loss of load) protection	$I <$	37
Instantaneous or definite-time ground-fault protection	$I_0 >$	50N/51N
Cumulative start-up time counter and restart disable function	$\sum t_{si}$	66
Circuit-breaker failure protection	CBFP	62BF
Temperature protection using RTD sensors or thermistors	ThA>, ThB>	49/38
Lockout relay		86

For protection function descriptions, refer to Section 5.1.4.13. Technical data on protection functions.

5.1.1.2. Inputs

The relay is provided with four energizing inputs, two digital inputs and three optional digital inputs controlled by an external voltage. Three of the energizing inputs are for the ground-fault current.

The functions of the digital inputs are determined with the SGB switches. For details, refer to Section 5.2.1. Input/output connections and Table 5.1.4.12.-8, Table 5.2.1.-1 and Table 5.2.1.-5.

5.1.1.3.

Outputs

The relay is provided with:

- Three trip output contacts (PO1, PO2 and PO3)
- Two non-trip contacts (SO1 and SO2)

Switchgroups SGR1...5 are used for routing internal signals from the protection elements, the motor start-up signal and the external trip signal to the desired non-trip or trip output contact. The minimum pulse length can be configured to be 40 or 80 ms and the trip output contacts can all be configured to be latched.

5.1.1.4.

Emergency start

The emergency start function allows motor start ups although the restart disable has been activated. The function is activated in SGB1...5. The emergency start will be activated when the selected digital input is energized and will remain active for ten minutes. On the rising edge of the emergency start signal

- the calculated thermal level will be set slightly below the restart disable level to allow at least one motor start up
- the value of the register of the cumulative start-up time counter will be set slightly below the set restart disable value to allow at least one motor start up
- the set trip values of temperature elements 49/38-1 and 49/38-2 will be increased by 10 per cent
- the external restart disable signal will be ignored.

The set trip values of elements 49/38-1 and 49/38-2 will be increased by ten per cent and the external restart disable signal ignored for as long as the emergency start is activated. A new emergency start cannot be made until the emergency start signal has been reset and the emergency start time of ten minutes has expired. Activation of the emergency start signal will generate an event code, which cannot be masked out from the event reporting.

5.1.1.5.

Restart disable

The restart disable signal is used to disable motor start ups when the motor is overheated, for instance. The restart disable signal is routed to PO3 by default, but can be deselected in SGF1. The signal will be activated when any of the following conditions exists:

- the trip signal from any protection element is active
- the restart disable signal from the thermal protection element is active
- the restart disable signal from element 66 is active
- the external restart disable signal is active

The estimated time to the next possible motor start up, i.e. when the restart disable signal is reset, can be accessed either via the HMI or the SPA bus.



If the restart disable function has been activated (SGF1/7=0), SGR3 will be overridden.

5.1.1.6.

Motor start up

A motor start-up situation is defined by means of the phase currents as follows:

- Motor start up begins (the motor start-up signal is activated) when the maximum phase current rises from a value below $0.12 \times \text{FLA}$, i.e. the motor is at standstill, to a value above $1.5 \times \text{FLA}$ within less than 60 ms.
- Motor start up ends (the motor start-up signal is reset) when all phase currents fall below $1.25 \times \text{FLA}$ and remain below for at least 200 ms.

The start-up time of the latest motor start up can be accessed via the HMI and read with SPA parameter V3.

The motor start-up signal is routed to the output contacts with the switches of switchgroups SGR1...SGR5.



All operation targets on the LCD will be cleared when a motor start up begins.

5.1.1.7.

Rated current of the protected unit

A scaling factor, PU scale, can be set for the phase currents. This will allow differences between the rated current of the protected unit and that of the energizing input. Consequently, the rated current of the relay can be set to equal the full load current (FLA) of the motor. A scaling factor, I_n , can be set for the phase currents. This will allow differences between the rated current of the protected unit and that of the energizing input. Consequently, the rated current of the relay can be set to equal the full load current (FLA) of the motor.

The current settings of the protection functions are related to the scaled rated current, FLA. The measured currents are presented either as primary values or as multiples of the scaled rated current. The current values in the recorded data are presented as multiples of the rated current.



The scaling factor affects the operation accuracy of the protection functions, with the exception of the ground-fault protection. The stated operation accuracy for each protection function only applies when the scaling factor is 1.



If the FLA secondary is set to 0.5, the maximum measured current is 25 x full load current of the motor.



The FLA secondary does not affect the ground-fault current, I_n .

5.1.1.8.

Disturbance recorder

The relay includes an internal disturbance recorder which records the instantaneous measured values or the RMS curves of the measured signals, and up to eight user-selectable digital signals: the digital input signals and the internal signals from the protection elements. Any digital signal can be set to trigger the recorder on either the falling or rising edge.

5.1.1.9.

Front panel

The front panel of the relay contains:

- Alphanumeric 2 × 16 characters' LCD with backlight and automatic contrast control
- Threetarget LEDs (green, yellow, red) with fixed functionality
- Eight programmable target LEDs (red)
- HMI push-button section with four arrow buttons and buttons for clear/cancel and enter, used in navigating in the menu structure and in adjusting setting values
- Optically isolated serial communication port with a target LED.

There are two levels of HMI passwords; main HMI setting password for all settings and HMI communication password for communication settings only.

The HMI passwords can be set to protect all user-changeable values from being changed by an unauthorized person. Both the HMI setting password and the HMI communication password remain inactive and are not required for altering parameter values until the default HMI password is replaced.



Entering the HMI setting or communication password successfully can be selected to generate an event code. This feature can be used to indicate interaction activities via the local HMI.

For further information on the HMI, refer to the Operator's Manual.

5.1.1.10. Non-volatile memory

The relay can be configured to store various data in a non-volatile memory, which retains its data also in case of loss of auxiliary voltage (provided that the battery has been inserted and is charged). Operation target messages and LEDs, the number of motor start ups, disturbance recorder data, event codes and recorded data can all be configured to be stored in the non-volatile memory whereas setting values are always stored in the EEPROM. The EEPROM does not require battery backup.

5.1.1.11. Self-supervision

The self-supervision system of the relay manages run-time fault situations and informs the user about an existing fault. There are two types of fault targets: internal relay fault (IRF) targets and warnings.

When the self-supervision system detects a permanent internal relay fault, which prevents relay operation, the green target LED (ready) will flash. At the same time, the IRF contact (also referred to as the IRF relay), which is normally picked up, drops off and a fault code appears on the LCD. The fault code is numerical and identifies the fault type.

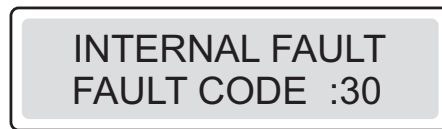

A040278

Fig. 5.1.1.11.-1 Permanent IRF

IRF codes can indicate:

- No response on the output contact test
- Faulty program, work or parameter memory
- Internal reference voltage error

In case of a warning, the relay continues to operate with full or reduced functionality and the green target LED (ready) remains lit as during normal operation. A fault target message (see Fig. 5.1.1.11.-2), with a possible fault code (see Fig. 5.1.1.11.-3), appears on the LCD indicating the type of fault.



A040279

Fig. 5.1.1.11.-2 Warning with text message



A040281

Fig. 5.1.1.11.-3 Warning with numeric code

For fault codes, refer to Section 5.1.16. Self-supervision (IRF) system.

5.1.1.12.

Time synchronization

Time synchronization of the relay’s real-time clock can be realized in two different ways: via serial communication using a communication protocol or via a digital input.

When time synchronization is realized via serial communication, the time is written directly to the relay’s real-time clock.

Any digital input can be configured for time synchronization and used for either minute-pulse or second-pulse synchronization. The synchronization pulse is automatically selected and depends on the time range within which the pulse occurs. The time must be set once, either via serial communication or manually via the HMI.

When the time is set via serial communication and minute-pulse synchronization is used, only year-month-day-hour-minute is written to the relay’s real-time clock, and when second-pulse synchronization is used, only year-month-day-hour-minute-second is written. The relay’s real-time clock will be rounded to the nearest whole second or minute, depending on whether second- or minute-pulse synchronization is used. When the time is set via the HMI, the entire time is written to the relay’s real-time clock.

If the synchronization pulse differs more than ±0.05 seconds for second-pulse or ±2 seconds for minute-pulse synchronization from the relay’s real-time clock, the synchronization pulse is rejected.

Time synchronization is always triggered on the rising edge of the digital input signal. The time is adjusted in steps of five milliseconds per synchronization pulse. The typical accuracy achievable with time synchronization via a digital input is ± 2.5 milliseconds for second-pulse and ± 5 milliseconds for minute-pulse synchronization.



The pulse length of the digital input signal does not affect time synchronization.



If time synchronization messages are received from a communication protocol as well, they have to be synchronized within ± 0.5 minutes at minute-pulse or ± 0.5 seconds at second-pulse synchronization. Otherwise, the relay's real-time clock makes sudden minute or second jumps in either direction. If it is possible that synchronization messages from the communication protocol are delayed more than 0.5 seconds, minute-pulse synchronization must be used.

5.1.2.

Measurements

The table below presents the measured values which can be accessed through the HMI.

Table 5.1.2.-1 Measured values

Target	Description
I_a	Current measured on phase I_a
I_b	Current measured on phase I_b
I_c	Current measured on phase I_c
I_n	Measured ground-fault current
I_2	Calculated NPS current
TH LEVEL	Thermal level
Start time	Start-up time of the latest motor start up
66 value	Cumulative start-up time counter
Rest. Dis	Time to next possible motor start up
Running time	Motor running time
Max IP	Maximum phase current during motor start up
Max IP	Maximum phase current after motor start up
Max I_n	Maximum ground-fault current after motor start up
Min IP	Minimum phase current after motor start up
Min I_n	Minimum ground-fault current after motor start up
1 min.	The average current of the three phase-to-phase currents during one minute
n min.	The average current of the three phase-to-phase currents during the specified time range
Max I	The maximum of one-minute average current of the n min

Target	Description
RTD1	Temperature from RTD1 ^{a)}
RTD2	Temperature from RTD2 ^{a)}
RTD3	Temperature from RTD3 ^{a)}
RTD4	Temperature from RTD4 ^{a)}
RTD5	Temperature from RTD5 ^{a)}
RTD6	Temperature from RTD6 ^{a)}
PTC1	Thermistor1, resistance value ^{a)}
PTC2	Thermistor2, resistance value ^{a)}

^{a)} Optional

5.1.3.

Configuration

The Fig. 5.1.3.-1 illustrates how the internal and digital input signals can be configured to obtain the required protection functionality.

Technical Reference Manual - ANSI Version

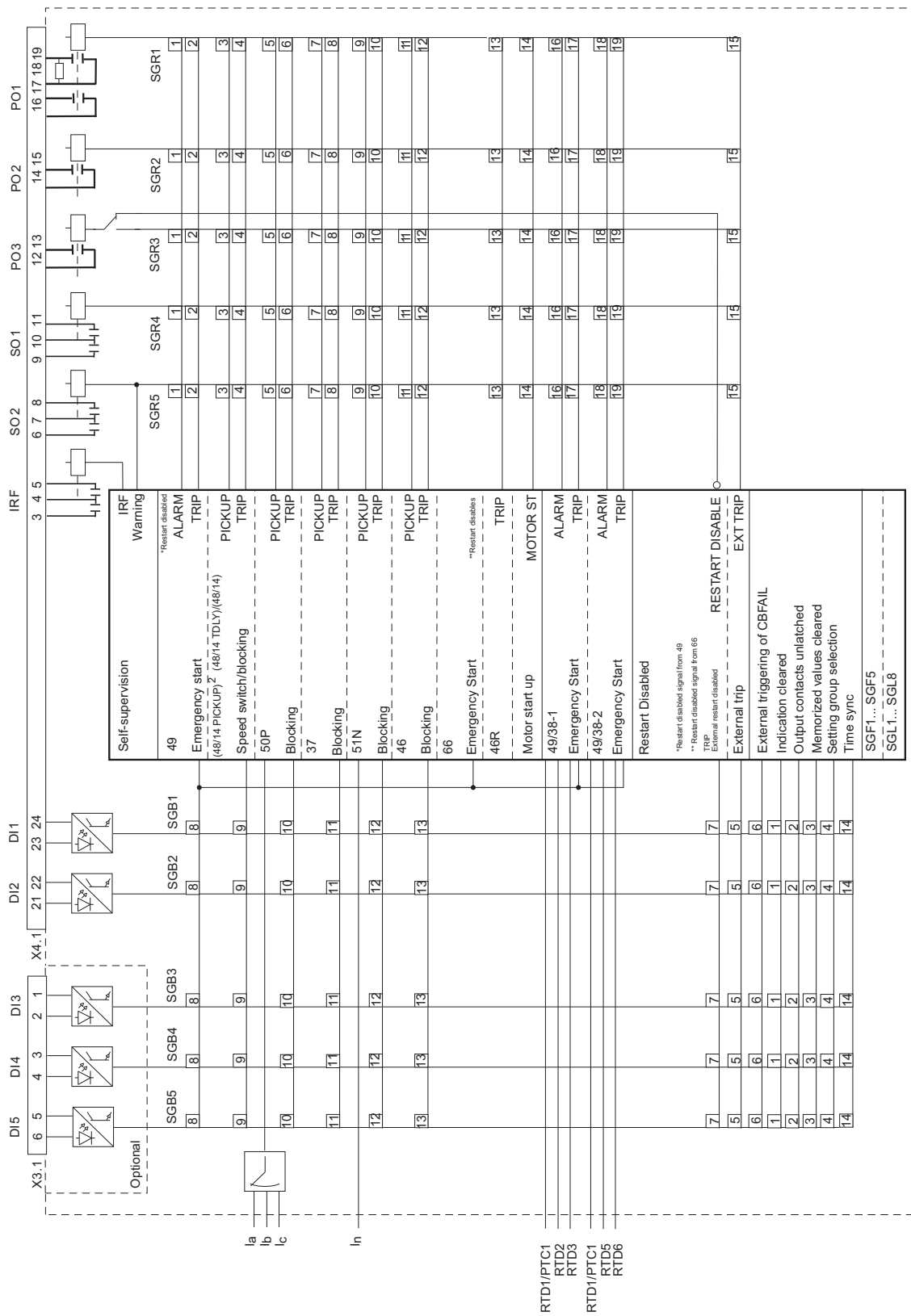

Fig. 5.1.3.-1 Signal diagram

The functions of the relay are selected with the switches of switchgroups SGF, SGB, SGR and SGL. The checksums of the switchgroups are found under `SETTINGS` in the HMI menu. The functions of the switches are explained in detail in the corresponding SG_ tables.

5.1.4. Protection

5.1.4.1. Block diagram

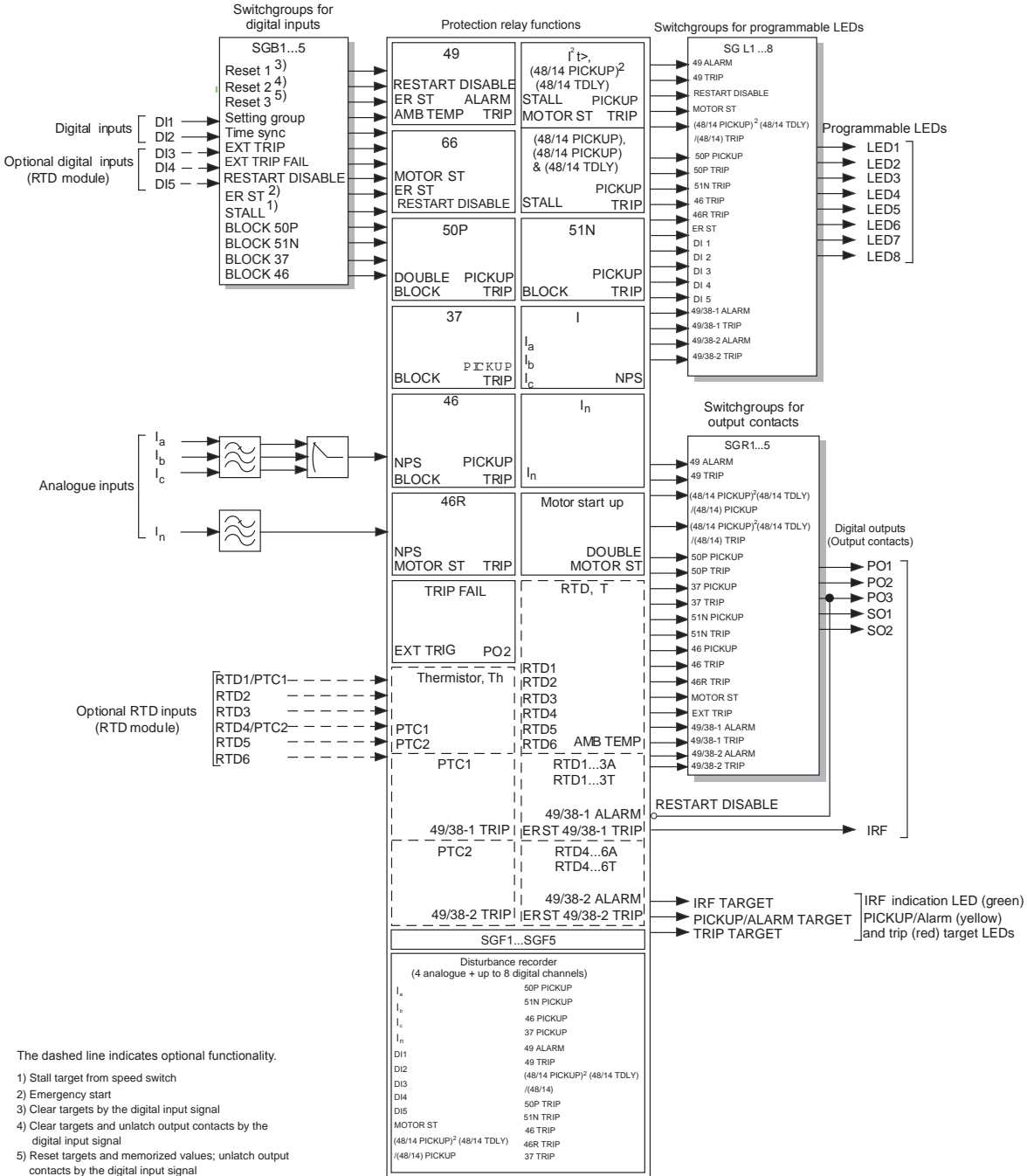

Fig. 5.1.4.1.-1 Block diagram

A060574

5.1.4.2. Thermal overload protection

The thermal overload protection detects short- and long-term overloads under varying load conditions. The heating up of the motor follows an exponential curve, the levelled-out value of which is determined by the squared value of the load current.

The full load current of the motor is defined by means of the FLA secondary scaling factor and determines the thermal trip level of element 49. The set safe stall time, t_{6x} , determines the operate time of the element for a load current of 6 x FLA without prior load.

If the RTD module has been installed, RTD6 can be selected to measure the ambient temperature. The selection is made in SGF4. However, if RTD6 is not used for measuring the ambient temperature or if the RTD module has not been installed, the thermal protection will use the set ambient temperature, T_{amb} .

The ambient temperature is used to determine the internal FLA. The table below shows how the internal FLA is modified.

Table 5.1.4.2.-1 Modification of internal FLA

Ambient temperature	Internal FLA
<+20°C	FLA x 1.09
20...<40°C	FLA x (1.18 - T_{amb} x 0.09/20)
40°C	FLA
>40...65°C	FLA x (1 - [(T_{amb} - 40)/100])
>+65°C	FLA x 0.75

There are two thermal curves, one which characterizes short- and long-time overloads and which is used for tripping and another which is used for monitoring the thermal condition of the motor. Weighting factor p determines the ratio of the thermal increase of the two curves. For direct-on-line started motors with hot spot tendencies, the weighting factor is typically set to 50 per cent. When protecting objects without hot spot tendencies, e.g. motors started with soft starters, and cables, the weighting factor is set to 100 per cent.

When one or several phase currents exceed the internal FLA by more than five per cent, the whole thermal capacity of the motor will be used after a time determined by the internal FLA, the set safe stall time and the prior load of the motor. When the thermal level (influenced by the thermal history of the motor) exceeds the set prior alarm level, 49 ALARM, the element will generate an alarm signal, and when the thermal level exceeds the set thermal restart disable level, 49 RESTDIS, the element will generate a restart disable signal. The time to the next possible motor start up can be read with SPA parameter V52 or via the HMI. When the thermal level exceeds the trip level, the element will generate a trip signal. For operate times, see Fig. 5.1.4.2.-1... Fig. 5.1.4.2.-4.

The thermal protection operates differently depending on the value of weighting factor p. For instance, if p is set to 50 per cent, the thermal protection will consider the hot spot tendencies of the motor and distinguish between short-time thermal

stress and long-time thermal history. After a short period of thermal stress, e.g. a motor start up, the thermal level will start to decrease quite sharply, simulating the levelling out of the hot spots. As a consequence, the probability that successive start ups will be allowed increases.

If p is set to 100 per cent, the thermal level will decrease slowly after a heavy load condition. This makes the protection suitable for applications where no hot spots are expected.

The reduced ability of the motor to cool down during standstill is taken into account by setting the cooling time constant to be longer than the heating time constant. The time constant dial, K_c , is the ratio of the cooling time and the heating time constant and determines the cooling rate of the motor at standstill.

At power up, the thermal level will be set to approximately 70 per cent of the thermal capacity of the motor. This will ensure that the element will trip within a safe time span. Under a low-load condition, the calculated thermal level will slowly approach the thermal level of the motor.



At a low prior alarm level, connecting the auxiliary supply to the relay will cause a thermal alarm due to the initialization of the thermal level to 70 per cent. The thermal level can be reset via the HMI during power up.



The thermal level can be reset or changed via serial communication, which will generate an event code.



On the rising edge of the emergency start signal the thermal level will be set below the thermal restart disable level. This will allow at least one motor start up even though the thermal level has exceeded the restart disable level.



When element 49 picks up during motor start up, neither a picks up signal nor an event code will be generated.

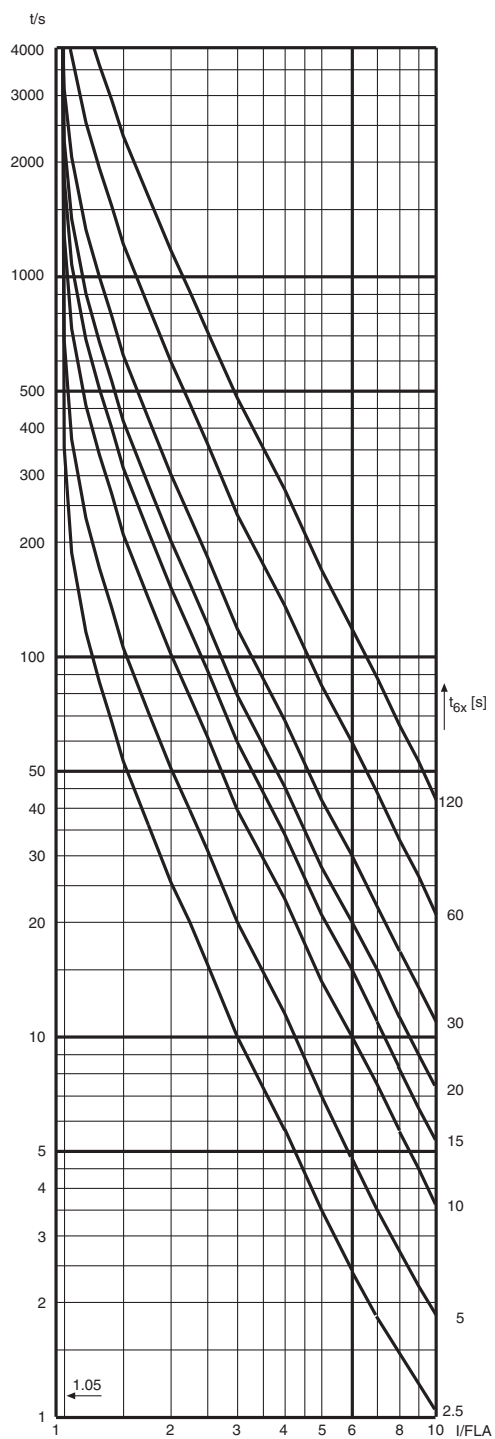

A070083

Fig. 5.1.4.2.-1 Trip curves when no prior load and $p=20...100\%$

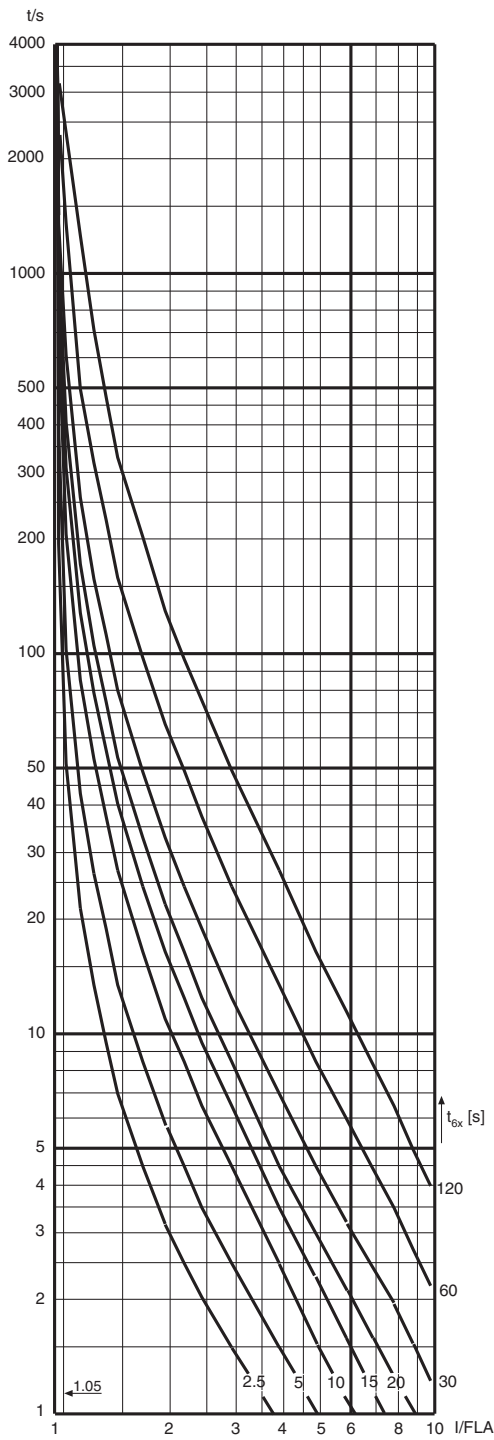

A070084

Fig. 5.1.4.2.-2 Trip curves at prior load $1 \times FLA$ and $p=100\%$

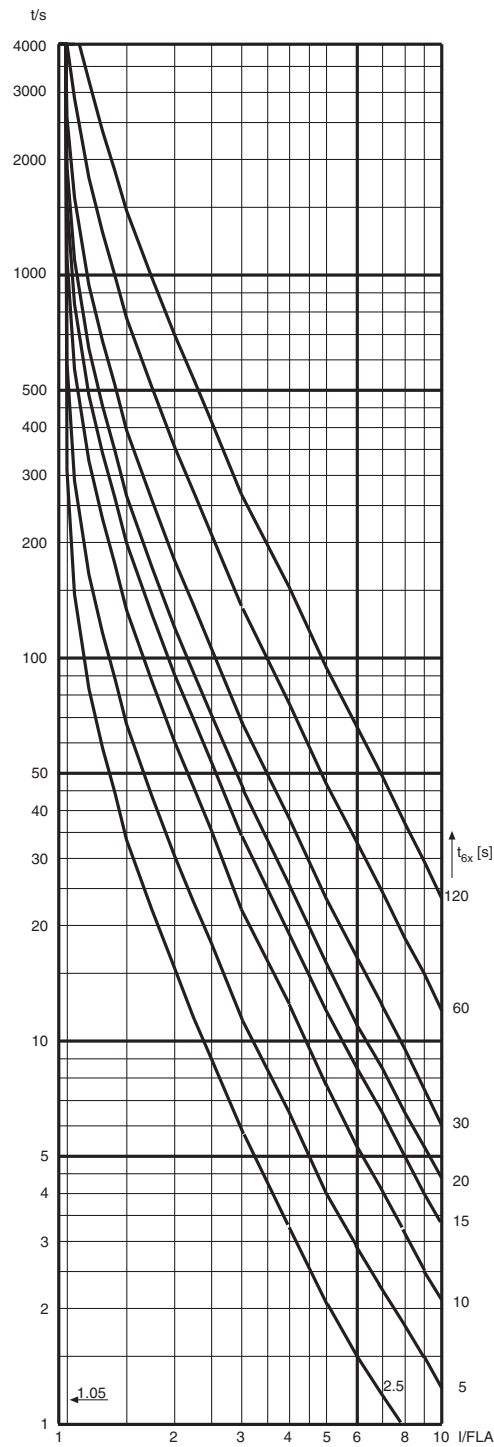
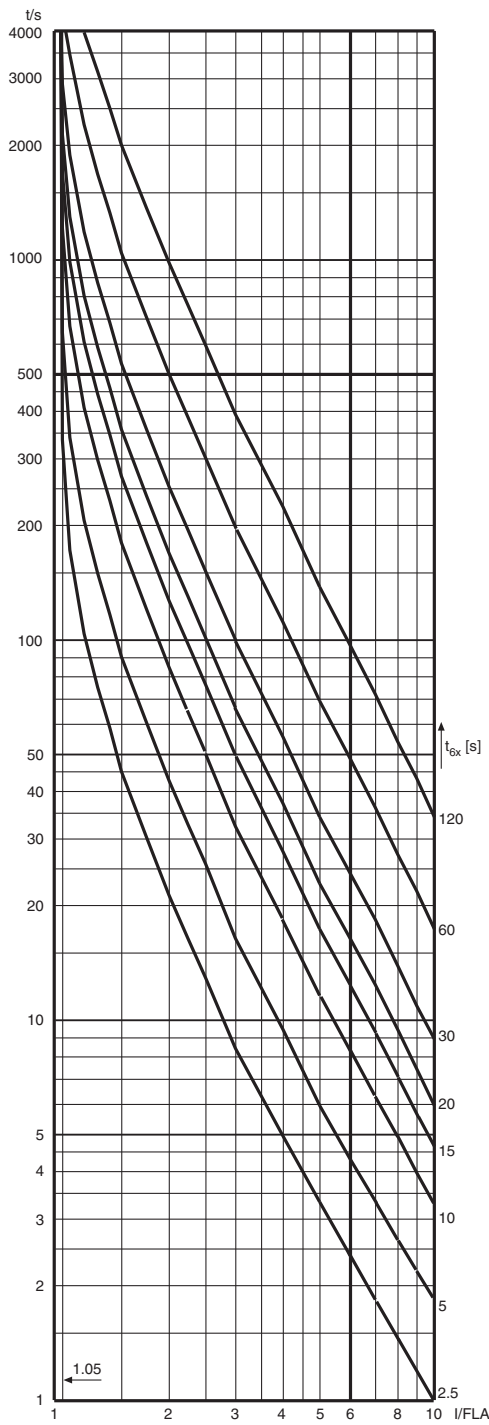

Fig. 5.1.4.2.-3 Trip curves at prior load 1 x FLA and $p=50\%$

A070085



A070086

Fig. 5.1.4.2.-4 Trip curves at prior load 1 x FLA and p=20%

5.1.4.3. Start-up supervision

Start-up supervision can be based on either definite-time overcurrent protection or thermal stress calculation. The selection is made in SGF3, the default being thermal stress calculation.

Start-up supervision based on definite-time overcurrent protection

The non-directional low-set element, 48/14, detects overcurrent, caused by an overload or a short circuit, for instance. When one or several phase currents exceed the set pickup value of element 48/14, the element will generate a pickup signal after a ~ 55 ms' pickup time. When the set operate time elapses, the element will generate a trip signal.

The overcurrent element will be reset when all three phase currents have fallen below the set pickup value of the element. The resetting time depends on how sharp the drop is: if the phase currents fall below $0.5 \times 48/14$, the element will be reset in 10 ms; if the phase currents fall below 48/14 but not below $0.5 \times 48/14$ PICKUP, the element will be reset in 50 ms.

It is possible to block the tripping of the low-set overcurrent element by applying a digital input signal to the relay.

A disadvantage of start-up supervision based on definite-time overcurrent protection is that the operate time is fixed and cannot be extended during low-voltage conditions.



Element 48/14 cannot be used concurrently with element $(48/14 \text{ PICKUP})^2 \times 48/14 \text{ TDLY}$.



When element 48/14 picks up during motor start up, no pickup signal will be generated.

Start-up supervision based on thermal stress calculation

Element $(48/14 \text{ PICKUP})^2 \times (48/14 \text{ TDLY})$ detects thermal stress, caused by a locked rotor during motor start up, for instance. The element can be set to pickup either when the conditions for motor start up are met or when one or several phase currents exceed the set pickup value. The selection is made in SGF3.

When element $(48/14 \text{ PICKUP})^2 \times (48/14 \text{ TDLY})$ has been set to pickup when the conditions for motor start up are met, the element will calculate the thermal stress value, $I^2 \times t$, for as long as the conditions for motor start up are met and compare it to a reference value, $(48/14 \text{ PICKUP})^2 \times (48/14 \text{ TDLY})$. The reference value is set to equal the amount of thermal stress built up during a normal start up of the motor. The element will not generate a separate pickup signal. When the reference value is exceeded, the element will generate a trip signal. The element will be reset in 240 ms after the motor start up has ended and the motor is running.

When element $(48/14 \text{ PICKUP})^2 \times (48/14 \text{ TDLY})$ has been set to pickup when one or several phase currents exceed the set pickup value ($I_p > 48/14 \text{ PICKUP}$), the element will generate a pickup signal after a ~ 100 ms' pickup time and calculate the

thermal stress value, $I^2 \times t$, until all three phase currents have fallen below the set pickup value. When the calculated value exceeds the reference value, $(48/14 \text{ PICKUP})^2 \times (48/14 \text{ TDLY})$, the element will generate a trip signal. The element will be reset in 240 ms after all three phase currents have fallen below the set pickup value of the element.

The operate time is calculated as below. However, the shortest possible operate time of element $(48/14 \text{ PICKUP})^2 \times (48/14 \text{ TDLY})$ is ~300 ms.

$$t[\text{s}] = \frac{(48/14 \text{ PICKUP})^2 \times (48/14 \text{ TDLY})}{I^2} \quad (1)$$

t	= operate time
48/14 PICKUP	= set start-up current of motor
48/14 TDLY	= set start-up time of motor
I	= phase current value

An advantage of start-up supervision based on thermal stress calculation is that the operate time will be automatically extended during low-voltage conditions as it depends on the start-up current of the motor.



Element $(48/14 \text{ PICKUP})^2 \times (48/14 \text{ TDLY})$ cannot be used concurrently with element 48/14.

Start-up supervision with speed switch

In case the safe stall time is shorter than the start-up time of the motor stated by the motor manufacturer, as with motors of ExE-type, for instance, a speed switch on the motor shaft is required to give information on whether the motor is accelerating during motor start up. The speed switch should be open at standstill and closed during acceleration.

Elements 48/14 and $(48/14 \text{ PICKUP})^2 \times (48/14 \text{ TDLY})$ will be blocked on activation of the speed switch input.

5.1.4.4.

Short-circuit protection

The non-directional short-circuit protection detects overcurrent caused by interwinding, phase-to-phase and phase-to-ground short circuits.

When one or several phase currents exceed the set pickup value of element 50P, the element will generate a pickup signal after a ~ 50 ms' pickup time. When the set operate time at definite-time characteristic elapses, the element will generate a trip signal. The high-set overcurrent element can be given an instantaneous

characteristic by setting the operate time to the minimum, i.e. 0.05 s. The element will be reset in 50 ms after all three phase currents have fallen below the set pickup value of the element.

The set pickup value of element 50P can be set to be automatically doubled in a motor start-up situation, i.e. when the object to be protected is being connected to a network. Consequently, a set pickup value below the connection inrush current level can be selected for the element. In this case, the short-circuit protection will still detect overcurrent caused by a locked rotor when the motor is running, which in turn may be caused by bearing failure, for instance. The selection is made in SGF3.



When automatic doubling is in use and the FLA secondary has been set to be very low, it must be assured that the doubled set pickup value of element 50P does not exceed the maximum measured current.



If the FLA secondary is set to 0.5, the maximum measured current is 25 x full load current of the motor.

It is possible to block the tripping of the high-set overcurrent element by applying a digital input signal to the relay.

The high-set overcurrent element can be set out of operation in SGF3 to prevent the contactor in a contactor controlled drive from operating at too high phase currents. This state will be indicated by dashes on the LCD and by “999” when the set pickup value is read via serial communication.



When element 50P pickups during motor start up, no pickup signal will be generated.

5.1.4.5.

Undercurrent protection

The non-directional undercurrent protection detects loss of load, caused by a damaged pump or a broken conveyor, for instance, and can be used in applications where undercurrent is considered a fault condition.

When all three phase currents fall below the set pickup value of element 37, the element will generate a pickup signal after a ~ 300 ms' pickup time. When the set operate time elapses, the element will generate a trip signal. To avoid tripping a de-energized motor, element 37 will be set out of operation when all phase currents fall below twelve per cent of the FLA of the motor.

The undercurrent element will be reset in 350 ms after one or several phase currents have exceeded the set pickup value of the element.

It is possible to block the tripping of the undercurrent element by applying a digital input signal to the relay.

Element 37 can be set out of operation in SGF3. This state will be indicated by dashes on the LCD and by “999” when the set pickup value is read via serial communication.



When element 37 picks up during motor start up, no pickup signal will be generated.

5.1.4.6.

Ground-fault protection

The non-directional ground-fault current protection detects phase-to-ground currents, caused by ageing and thermal cycling, for instance.

When the ground-fault current exceeds the set pickup value of element 51N, the element will generate a pickup signal after a ~ 50 ms' pickup time. When the set operate time at definite-time characteristic elapses, the element will generate a trip signal. The element can be given an instantaneous characteristic by setting the operate time to the minimum, i.e. 0.05 s. The ground-fault element will be reset in 50 ms after the ground-fault current has fallen below the set pickup value of the element.

It is possible to block the tripping of the ground-fault element by applying a digital input signal to the relay.

Element 51N can be set out of operation in SGF3. This state will be indicated by dashes on the LCD and by “999” when the set pickup value is read via serial communication.

To prevent the contactor in a contactor controlled drive from operating at too high phase currents, the ground-fault element can be set to be disabled when one or several phase currents exceed the FLA of the motor four, six or eightfold. The selection is made in SGF4.



When element 51N picks up during motor start up, no pickup signal will be generated.



The FLA secondary does not affect the ground fault current, I_n .

5.1.4.7.

Unbalance protection

The inverse-definite-minimum-time (IDMT) unbalance protection is based on the calculated negative-phase-sequence (NPS) current and detects phase unbalance between phases I_a, I_b and I_c, caused by a broken conductor, for instance. Phase unbalance in a network feeding the motor will cause overheating of the rotor.

When the calculated NPS current value exceeds the set pickup value of element 46, the element will generate a pickup signal after a ~ 100 ms' pickup time. When the calculated operate time elapses, the element will generate a trip signal. The operate time depends on the current value: the higher the current value, the shorter the operate time. The unbalance element will be reset in 200 ms after the NPS current has fallen below the set pickup value of the element.

The unbalance protection will be disabled when all phase currents fall below twelve per cent of the FLA of the motor or one or several phase currents exceed the FLA of the motor fourfold.

It is possible to block the tripping of the unbalance element by applying a digital input signal to the relay.

Element 46 can be set out of operation in SGF3. This state will be indicated by dashes on the LCD and by "999" when the set pickup value is read via serial communication.

The operate time is calculated as below:

t[s] = (46TDIAL) / (I₂² - (46PICKUP)²) (2)

- t = operate time
I₂ = NPS current
46 PICKUP = set pickup value
46 TDIAL = set time constant equals the motor constant, I₂² x t (provided by the motor manufacturer)



When element 46 picks up during motor start up, no pickup signal will be generated.



Element 46 will be blocked during the tripping of the phase reversal element.

The figure below illustrates the inverse-time curves of element 46.

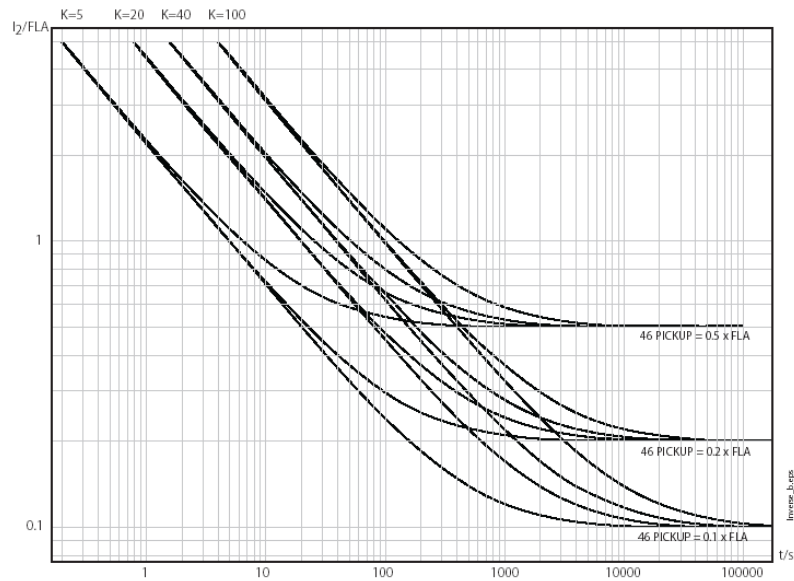

A060577

Fig. 5.1.4.7.-1 Inverse-time curves of element 46

5.1.4.8.

Phase reversal protection

The phase reversal protection is based on the calculated negative-phase-sequence current and detects too high NPS current values during motor start up, caused by incorrectly connected phases, which in turn will cause the motor to rotate in the opposite direction.

When the calculated NPS current value exceeds 75 per cent of the maximum phase current value, the phase reversal element (46R) will generate a trip signal after a fixed 200 ms' operate time.

The element will be reset in 200 ms after the calculated NPS current value has fallen below 75 per cent of the maximum phase current value.

The phase reversal element can be set out of operation in SGF3.



The unbalance element will be blocked during the tripping of the phase reversal element.

5.1.4.9.

Cumulative start-up time counter

The cumulative start-up time counter detects too frequent start-up attempts, which cause overheating of the motor.

The start-up time of every motor start up is added to a register, 66 value. When the register's value exceeds the set restart disable value, 66, any attempt to restart the motor will be disabled.

The time to the next possible motor start up depends on the countdown rate of the start-up time counter, $66 \text{ COOL} / \Delta t$, i.e. the rate at which the register's value decreases. For instance, if the motor manufacturer allows a maximum of three 60 s' motor start ups in four hours, 66 should be set to $2 \times 60 \text{ s} + \text{margin} = 121 \text{ s}$ and $66 \text{ COOL} / \Delta t$ to $60 \text{ s} / 4 \text{ h} = 15 \text{ s/h}$; see the figure below.

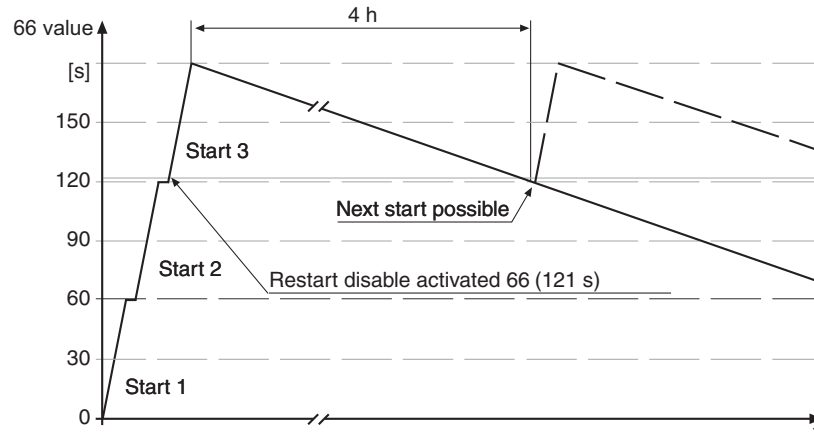

A070087

Fig. 5.1.4.9.-1 Cumulative start-up time counter operation



The register's value will decrease during motor start up as well.



If the emergency start has been activated, a motor start up will be allowed even though the register's value exceeds the set restart disable value.

5.1.4.10.

Circuit-breaker failure protection

The circuit-breaker failure protection (CBFAIL) detects situations where the the circuit breaker remains closed although the circuit breaker should have operated.

If a trip signal generated via output PO1 is still active and the current has not been cut off on expiration of the CBFAIL set operate time, the CBFAIL generates a trip signal via output PO2.

The CBFAIL is not triggered in case of:

- Alarm or a trip of the thermal protection element
- Alarm or a trip a temperature element
- Trip of the phase reversal element
- External trip

The CBFAIL can also be selected to be triggered externally by applying a digital input signal to the relay. In this case, the CBFAIL generates a trip signal via output PO2 if the current has not been cut off on expiration of the set operate time.

External triggering is disabled when all phase currents fall below 12 percent of the FLA of the motor, that is, at standstill.

Internal triggering is selected by activating the CBFAIL in SGF and external triggering by activating the CBFAIL in SGB. Both triggering options can be selected at the same time.

Normally, the CBFAIL controls the upstream circuit breaker. However, it can also be used for tripping via redundant trip circuits of the same circuit breaker, provided that the circuit breaker has two trip coils.

5.1.4.11.

Temperature protection (optional)

The temperature protection detects too high temperatures in motor bearings and windings, for instance, measured either using RTD sensors or thermistors.

The optional RTD module includes six inputs divided into two groups: RTD1...3 form 49/38-1 and RTD4...6 49/38-2. Inputs RTD1 and RTD4 can also be used with thermistors.

The inputs of 49/38-1 can be used for measuring the stator temperature and those of 49/38-2 for measuring bearing temperatures and the ambient temperature, for instance.

Each RTD input can be set out of operation. This state will be indicated by dashes on the LCD and by “-999” when parameters are read via the SPA bus. When RTD sensors/thermistors are not in use, dashes will be shown on the LCD and “-999”/”999” when parameters are read via serial communication.



All RTD inputs will automatically be set out of operation when the self-supervision of the RTD module has detected a fault.

Temperature protection using RTD sensors

An alarm value, RTD1A...RTD6, and a trip value, RTD1T...RTD6T, are set for each input separately. When one or several measured temperatures exceed their set alarm values, RTD1...3A/RTD4...6A, element 49/38-1/49/38-2, element 49/38-1/49/38-2 will generate a trip signal on expiration of the set operate time.

The alarm signal from 49/38-1/49/38-2 will be reset in 800 ms after the temperatures have fallen below their respective set alarm values (RTD1...3A/RTD4...6A) and the trip signal in 800 ms after the temperatures have fallen below their respective set trip values (RTD1...3T/RTD4...6T).



RTD6 can be used to measure the ambient temperature for the thermal protection element. In this case, RTD6A and RTD6T will not be in use. This state will be indicated by dashes on the LCD and by “-999” when the set alarm/trip value is read via the SPA bus.



For as long as the emergency start is activated, RTD1...6T will be increased by 10 per cent.

Temperature protection using thermistors

REM610 supports PTC thermistors.

When input RTD1/RTD4 is used with thermistors, a trip value, PTC1/PTC2, is set for the respective input.

When the resistance of the thermistor exceeds the set trip value, PTC1/PTC2, element 49/38-1/49/38-2 will generate a trip signal on expiration of the 2 s' fixed operate time.

The trip signal from 49/38-1/49/38-2 will be reset in 800 ms after the resistance has fallen below set trip value PTC1/PTC2>.

RTD sensor/thermistor connection

When connecting the RTD sensors and the thermistors to the RTD inputs, a double-shielded cable is to be used. The cable shield is to be connected to the chassis earth screw on the rear panel of the relay.

The RTD sensors and thermistors are to be connected to the RTD inputs according to the three-wire connection principle. Consequently, the wire resistance will be automatically compensated. The RTD sensor/thermistor is connected across the plus and the minus terminal, and the negative side of the RTD sensor/thermistor to the common terminal. The leads connected to the plus and the common terminal must be of the same type and length.

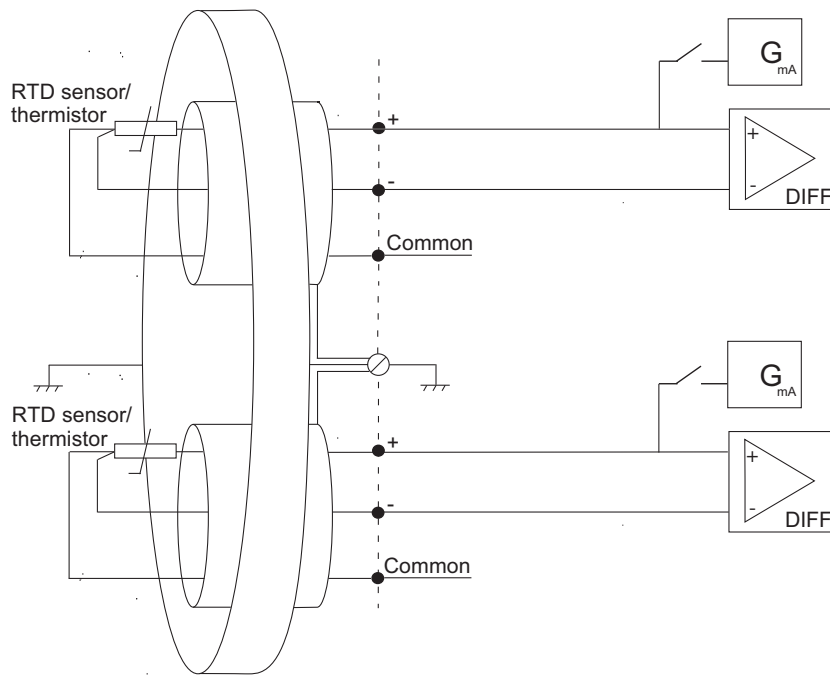

A050429

Fig. 5.1.4.11.-1 RTD sensor/thermistor connection

RTD temperature vs resistance

Resistance values (Ω) of RTD sensors at specified temperatures are presented in the table below.

Table 5.1.4.11.-1 Resistance values of RTD sensors

Temperature °C	Platinum TCR 0.00385			Nickel TCR 0.00618		Copper TCR 0.00427	Nickel TCR 0.00672
	Pt 100	Pt 250	Pt 1000	Ni 100	Ni 120	Cu 10	Ni 120 US
-40	84.27	210.68	842.7	79.1	94.92	7.49	92.76
-30	88.22	220.55	882.2	84.1	100.92	-	-
-20	92.16	230.4	921.6	89.3	107.16	8.26	106.15
-10	96.09	240.23	960.9	94.6	113.52	-	-
0	100.00	250	1000	100.0	120	9.04	120.00
10	103.90	259.75	1039	105.6	126.72	-	-
20	107.79	269.48	1077.9	111.2	133.44	9.81	134.52
30	111.67	279.18	1116.7	117.1	140.52	-	-
40	115.54	288.85	1155.4	123.0	147.6	10.58	149.79
50	119.40	298.5	1194	129.1	154.92	-	-
60	123.24	308.1	1232.4	135.5	162.36	11.352	165.90
70	127.07	317.68	1270.7	141.7	170.04	-	-
80	130.89	327.23	1308.9	148.3	177.96	12.12	182.84
90	134.70	336.75	1347	154.9	185.88	-	-
100	138.50	346.25	1385	161.8	194.16	12.90	200.64
120	146.06	365.15	1460.6	176.0	211.2	13.67	219.29

Technical Reference Manual - ANSI Version

Temperature °C	Platinum TCR 0.00385			Nickel TCR 0.00618		Copper TCR 0.00427	Nickel TCR 0.00672
	Pt 100	Pt 250	Pt 1000	Ni 100	Ni 120	Cu 10	Ni 120 US
140	153.58	383.95	1535.8	190.9	229.08	14.44	238.85
150	-	-	-	198.6	238.32	-	-
160	161.04	402.6	1610.4	206.6	247.92	15.22	259.30
180	168.46	421.15	1684.6	223.2	267.84	-	280.77
200	175.84	439.6	1758.4	240.7	288.84	-	303.46
220	-	-	-	259.2	311.04	-	327.53
240	-	-	-	278.9	334.68	-	353.14
250	194.07	485.18	1940.7	289.2	347.04	-	-
260	-	-	-	-	-	-	380.31
300	212.02	530.05	2120.2	-	-	-	-
350	229.67	574.18	2296.7	-	-	-	-
400	247.04	617.6	2470.4	-	-	-	-
450	264.11	660.28	2641.1	-	-	-	-
500	280.90	702.25	2809	-	-	-	-
550	297.39	743.48	2973.9	-	-	-	-
600	313.59	783.98	3135.9	-	-	-	-

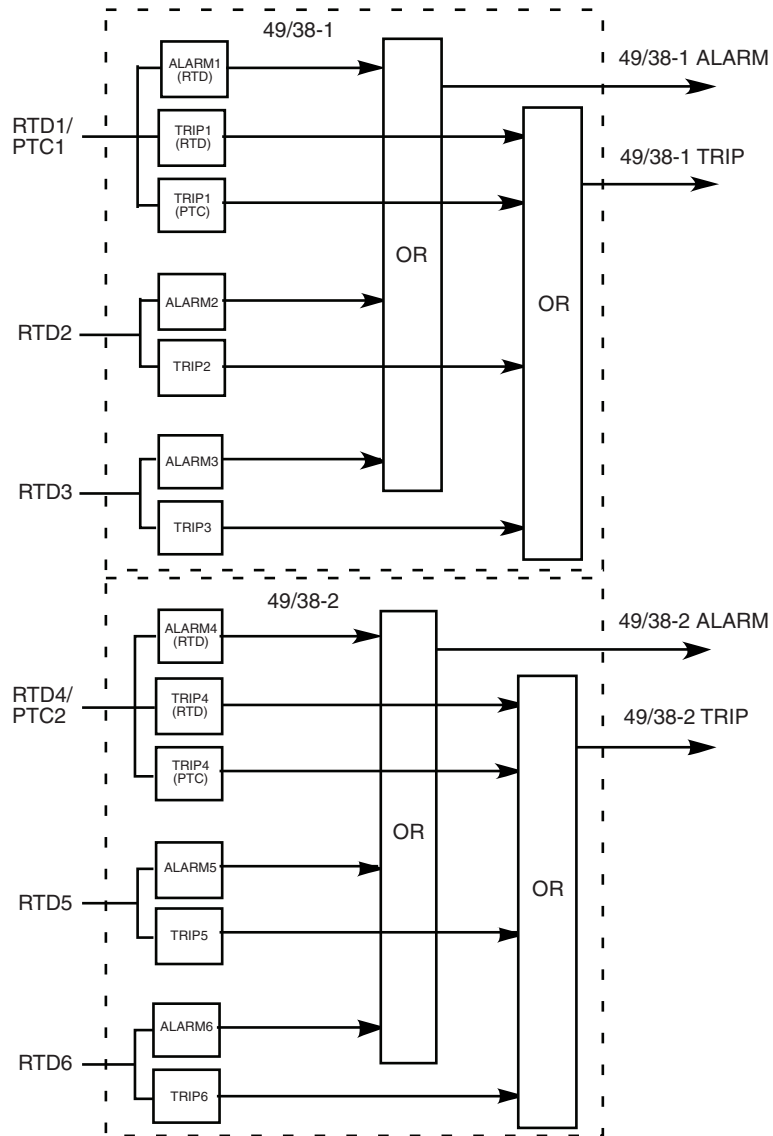

A060575

Fig. 5.1.4.11.-2 Grouping of temperature elements

5.1.4.12.

Settings

There are two alternative setting groups available, setting groups 1 and 2. Either of these setting groups can be used as the actual settings, one at a time. Both groups have their related registers. By switching between the setting groups, a whole group of settings can be changed at the same time. This can be done in any of the following ways:

Group configuration:

- Via the HMI
- Entering parameter V150 via serial communication

Group selection:

- Switching between group 1 and group 2 is accomplished by means of a digital input



Switching between setting groups through group selection has higher priority than through group configuration.

The setting values can be altered via the HMI or with a PC provided with the Relay Setting Tool.

Before the relay is connected to a system it must be assured that the relay has been given the correct settings. If there is any doubt, the setting values should be read with the relay trip circuits disconnected or tested with current injection; refer to section Check lists for additional information.

Table 5.1.4.12.-1 Setting values

Setting	Description	Setting range	Default setting
FLA SEC.	FLA secondary scaling factor	0.50...2.50 ^{a)}	1
t _{6x}	Safe stall time	2...120 s ^{b)}	2 s
p	Weighting factor	20...100%	50 %
K _c	Time constant dial	1...64	1
49 ALARM	Prior alarm level	50...100%	95%
49 RESTDIS	Restart disable level	20...80%	40%
T _{amb}	Ambient temperature	0...70°C	40°C
48/14 PICKUP/FLA	Start-up current for motor or pickup value of element 48/14	1.00...10.0 x FLA	1.00 x FLA
48/14 TDLY	Start-up time for motor or operate time of element 48/14	0.30...80.0 s	0.30 s
50P/FLA	Pickup value of element 50P	0.50...20.0 x FLA	1.00 x FLA
50P TDLY	Operate time of element 50P	0.05...30.0 s	0.05 s
51N/ I _n CT	Pickup value of element 51N	1.0...100% I _n CT	1.0% I _n CT
51N TDLY	Operate time of element 51N	0.05...300 s	0.05 s
37/ FLA	Pickup value of element 37	30...80% FLA	50% FLA
37 TDLY	Operate time of element 37	2...600 s	2 s
46 PICKUP/ FLA	Pickup value of element 46	0.10...0.50 x FLA	0.20 x FLA
46 TDIAL	Time constant of element 46 at IDMT characteristic	5...100	5
66	Restart disable value	5...500 s	5 s
66 COOL/Δt	Countdown rate of start-up time counter	2...250 s/h	2 s/h
Trip Fail	Operate time of CBFAIL	0.10...60.0 s	0.10 s
RTD1A	Alarm value RTD1A	0...200°C	0°C
RTD1A TDLY	Operate time RTD1A TDLY	1...100 s	1 s
RTD1T	Trip value RTD1T	0...200°C	0°C
RTD1T TDLY	Operate time RTD1T TDLY	1...100 s	1 s

Setting	Description	Setting range	Default setting
RTD2A	Alarm value RTD2A	0...200°C	0°C
RTD2A TDLY	Operate time RTD2A TDLY	1...100 s	1 s
RTD2T	Trip value RTD2T	0...200°C	0°C
RTD2T TDLY	Operate time RTD2T TDLY	1...100 s	1 s
RTD3A	Alarm value RTD3A	0...200°C	0°C
RTD3A TDLY	Operate time RTD3A TDLY	1...100 s	1 s
RTD3T	Trip value RTD3T	0...200°C	0°C
RTD3T TDLY	Operate time RTD3T TDLY	1...100 s	1 s
RTD4A	Alarm value RTD4A	0...200°C	0°C
RTD14A TDLY	Operate time RTD14A TDLY	1...100 s	1 s
RTD4T	Trip value RTD4T	0...200°C	0°C
RTD4T TDLY	Operate time RTD4T TDLY	1...100 s	1 s
RTD5A	Alarm value RTD5A	0...200°C	0°C
RTD5A TDLY	Operate time RTD5A TDLY	1...100 s	1 s
RTD5T	Trip value RTD5T	0...200°C	0°C
RTD5T TDLY	Operate time RTD5T TDLY	1...100 s	1 s
RTD6A	Alarm value RTD6A	0...200°C	0°C
RTD6A TDLY	Operate time RTD6A TDLY	1...100 s	1 s
RTD6T	Trip value RTD6T	0...200°C	0°C
RTD6T TDLY	Operate time RTD6T TDLY	1...100 s	1 s
PTC1	Trip value PTC1	0.1...15.0 kΩ	0.1 kΩ
PTC2	Trip value PTC2	0.1...15.0 kΩ	0.1 kΩ

a) The FLA secondary scaling factor has only one setting and thus switching between setting groups does not apply.

b) The setting step is 0.5.

Switchgroups and parameter masks

The settings can be altered and the functions of the relay selected in the SG_ selector switchgroups. The switchgroups are software based and thus not physical switches to be found in the hardware of the relay.

A checksum is used for verifying that the switches have been properly set. The figure below shows an example of manual checksum calculation.

Switch number	Position		Weighting factor		Value
1	1	x	1	=	1
2	0	x	2	=	0
3	1	x	4	=	4
4	0	x	8	=	0
5	1	x	16	=	16
6	0	x	32	=	0
7	1	x	64	=	64
8	0	x	128	=	0
9	1	x	256	=	256
10	0	x	512	=	0
11	1	x	1024	=	1024
12	0	x	2048	=	0
13	1	x	4096	=	4096
14	0	x	8192	=	0
15	1	x	16384	=	16384
16	0	x	32768	=	0
17	1	x	65536	=	65536
18	0	x	131072	=	0
19	1	x	262144	=	262144
20	0	x	524288	=	0
checksum			SG_Σ	=	349525

A060801

Fig. 5.1.4.12.-1 An example of calculating the checksum of a SG_selector switchgroup

When the checksum, calculated according to the example above, equals the checksum of the relay, the switches in the switchgroup have been properly set.

The factory default settings of the switches and the corresponding checksums are presented in the tables below.

SGF1...SGF5

Switchgroups SGF1...SGF5 are used for configuring the desired function as follows:

Table 5.1.4.12.-2 SGF1

Switch	Function	Default setting
SGF1/1	Selection of the latching feature for PO1	0
SGF1/2	Selection of the latching feature for PO2	0
SGF1/3	Selection of the latching feature for PO3 <ul style="list-style-type: none"> • When the switch is in position 0 and the measuring signal which caused the trip falls below the set pickup value, the output contact will return to its initial state. • When the switch is in position 1, the output contact will remain active although the measuring signal which caused the trip falls below the set pickup value. A latched output contact can be unlatched either via the HMI, a digital input or the serial bus.	0
SGF1/4	Minimum pulse length for SO1 and SO2 <ul style="list-style-type: none"> • 0=80 ms • 1=40 ms 	0



Switch	Function	Default setting
SGF1/5	Minimum pulse length for PO1, PO2 and PO3 <ul style="list-style-type: none"> • 0=80 ms • 1=40 ms  The latching feature being selected for PO1, PO2 and PO3 will override this function.	0
SGF1/6	CBFAIL <ul style="list-style-type: none"> • 0 =CBFAIL is not in use • 1 = the signal to PO1 will start a timer which will generate a delayed signal to PO2, provided that the fault is not cleared before the CBFAIL operate time has elapsed. 	0
SGF1/7	Restart disable function <ul style="list-style-type: none"> • When the switch is in position 0, the restart disable signal will be routed to PO3. • When the switch is in position 1, the restart disable signal will not be routed to PO3. 	0
SGF1/8	External fault warning <ul style="list-style-type: none"> • When the switch is in position 1, the warning signal from the trip-circuit supervision is routed to SO2.  To avoid conflicts, SGR5 should be set to 0 when SGF1/8=1.	0
ΣSGF1		0

Table 5.1.4.12.-3 SGF2

Switch	Function	Default setting
SGF2/1	Operation mode of the alarm target of element 49	0
SGF2/2	Operation mode of the pickup target of element 48/14 ^{a)}	0
SGF2/3	Operation mode of the pickup target of element 50P ^{a)}	0
SGF2/4	Operation mode of the pickup target of element 37 ^{a)}	0
SGF2/5	Operation mode of the pickup target of element 51N	0
SGF2/6	Operation mode of the pickup target of element 46	0
SGF2/7	Operation mode of the alarm target of element 49/38-1	0
SGF2/8	Operation mode of the alarm target of element 49/38-2 <ul style="list-style-type: none"> • 0 = the pickup target will automatically be cleared once the fault has disappeared • 1 = latching. The pickup target will remain active although the fault has disappeared. 	0
ΣSGF2		0

^{a)} In addition, the phase(s) which caused the pickup will be shown on the LCD.

Table 5.1.4.12.-4 SGF3

Switch	Function	Default setting
SGF3/1	Disable of element 50P	0
SGF3/2	Disable of element 37	1
SGF3/3	Disable of element 51N	0
SGF3/4	Disable of element 46	0
SGF3/5	Disable of element 46R <ul style="list-style-type: none"> When the switch is in position 1, the element is disabled. 	0
SGF3/6	Start-up supervision <ul style="list-style-type: none"> 0 = based on thermal stress calculation 1 = based on definite-time overcurrent protection 	0
SGF3/7	Pickup criteria for element $(48/14 \text{ PICKUP})^2 \times (48/14 \text{ TDLY})$ <ul style="list-style-type: none"> 0 = theelement will pickup when the conditions for motor start up are met 1 = theelement will pickup when one or several phase currents exceed the set pickup value 	0
SGF3/8	Automatic doubling of the pickup value of element 50P <ul style="list-style-type: none"> When the switch is in position 1, the set pickup value of theelement will automatically be doubled at high inrush situations 	0
ΣSGF3		2

Table 5.1.4.12.-5 SGF4

Switch	Function	Default setting												
SGF4/1 and SGF4/2	Disable of element 51N when one or several phase currents exceed the FLA of the motor <table border="1" style="margin-left: auto; margin-right: auto;"> <thead> <tr> <th></th> <th>SGF4/1</th> <th>SGF4/2</th> </tr> </thead> <tbody> <tr> <td>x 4</td> <td>1</td> <td>0</td> </tr> <tr> <td>x 6</td> <td>0</td> <td>1</td> </tr> <tr> <td>x 8</td> <td>1</td> <td>1</td> </tr> </tbody> </table>		SGF4/1	SGF4/2	x 4	1	0	x 6	0	1	x 8	1	1	0 0
	SGF4/1	SGF4/2												
x 4	1	0												
x 6	0	1												
x 8	1	1												
SGF4/3	Selection of ambient temperature <ul style="list-style-type: none"> 0 = set ambient temperature 1 = ambient temperature from RTD6 <p>If the RTD module has not been installed, the set ambient temperature will be used.</p>	0												
ΣSGF4		0												

Table 5.1.4.12.-6 SGF5

Switch	Function	Default setting
SGF5/1	Selection of the latching feature for programmable LED1	0
SGF5/2	Selection of the latching feature for programmable LED2	0
SGF5/3	Selection of the latching feature for programmable LED3	0
SGF5/4	Selection of the latching feature for programmable LED4	0
SGF5/5	Selection of the latching feature for programmable LED5	0
SGF5/6	Selection of the latching feature for programmable LED6	0
SGF5/7	Selection of the latching feature for programmable LED7	0

Switch	Function	Default setting
SGF5/8	Selection of the latching feature for programmable LED8 <ul style="list-style-type: none"> • When the switch is in position 0 and the signal routed to the LED is reset, the programmable LED will be cleared. • When the switch is in position 1, the programmable LED will remain lit although the signal routed to the LED is reset. A latched programmable LED can be cleared either via the HMI, a digital input or the serial bus.	0
ΣSGF5		0

SGB1...SGB5

The DI1 signal is routed to the functions below with the switches of switchgroup SGB1, the DI2 signal with those of SGB2, and so forth.

Table 5.1.4.12.-7 SGB1...SGB5

Switch	Function	Default setting
SGB1...5/1	<ul style="list-style-type: none"> • 0 = targets are not cleared by the digital input signal • 1 = targets are cleared by the digital input signal 	0
SGB1...5/2	<ul style="list-style-type: none"> • 0 = targets are not cleared and latched output contacts are not unlatched by the digital input signal • 1 = targets are cleared and latched output contacts are unlatched by the digital input signal 	0
SGB1...5/3	<ul style="list-style-type: none"> • 0 = targets and memorized values are not cleared and latched output contacts are not unlatched by the digital input signal • 1 = targets and memorized values are cleared and latched output contacts are unlatched by the digital input signal 	0
SGB1...5/4	Switching between setting groups 1 and 2 using the digital input <ul style="list-style-type: none"> • 0 = the setting group cannot be changed using the digital input • 1 = the setting group is changed by using the digital input. When the digital input is energized, setting group 2 will be activated, if not, setting group 1 will be activated.  When SGB1...5/4 is set to 1, it is important that the switch has the same setting in both setting groups.	0
SGB1...5/5	External tripping by the digital input signal	0
SGB1...5/6	External triggering of the CBFAIL by the digital input signal	0
SGB1...5/7	External restart disable by the digital input signal	0
SGB1...5/8	Activating the emergency start by the digital input signal	0
SGB1...5/9	Blocking of element $(48/14 \text{ PICKUP})^2 \times (48/14 \text{ TDLY})$ or 48/14 by the digital input signal (speed switch input)	0
SGB1...5/10	Blocking of element 50P by the digital input signal	0
SGB1...5/11	Blocking of element 37 by the digital input signal	0
SGB1...5/12	Blocking of element 51N by the digital input signal	0
SGB1...5/13	Blocking of element 46 by the digital input signal	0
SGB1...5/14	Time synchronization by the digital input signal	0
ΣSGB1...5		0

SGR1...SGR5

The pickup, trip and alarm signals from the protection elements, the motor start-up signal and the external trip signal are routed to the output contacts with the switches of switchgroups SGR1...SGR5. The signals are routed to PO1 with the switches of switchgroup SGR1, to PO2 with those of SGR2, to PO3 with those of SGR3, to SO1 with those of SGR4 and to SO2 with those of SGR5.

The matrix below can be of help when making the desired selections. The pickup, trip and alarm signals from the protection elements, the motor start-up signal and the external trip signal are combined with the output contacts by encircling the desired intersection point. Each intersection point is marked with a switch number, and the corresponding weighting factor of the switch is shown on the right side of the matrix, see Fig. 5.1.4.12.-2. The switchgroup checksum is obtained by vertically adding the weighting factors of all the selected switches of the switchgroup.



If CBFAIL is in use, SGR2 should be set to 0 to avoid conflicts.



If the external fault warning is in use, SGR5 should be set to 0 to avoid conflicts.

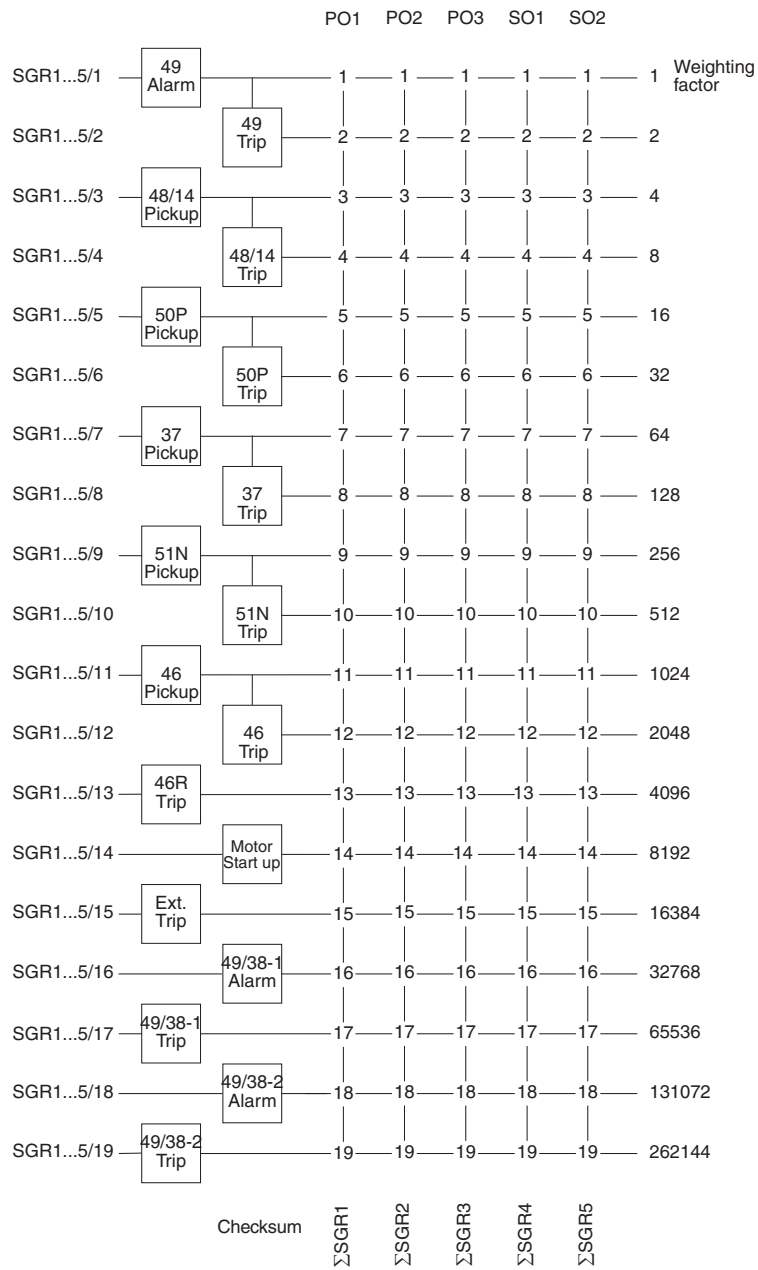

A060576

Fig. 5.1.4.12.-2 Output signal matrix

Table 5.1.4.12.-8 SGR1...SGR5

Switch	Function	Default setting		
		SGR1...SGR2	SGR3	SGR4...SGR5
SGR1...5/1	Alarm signal from element 49	0	0	1
SGR1...5/2	Trip signal from element 49	1	0	0
SGR1...5/3	Pickup signal from element (48/14 PICKUP) ² x (48/14 TDLY) or 48/14	0	0	1
SGR1...5/4	Trip signal from element (48/14 PICKUP) ² x (48/14 TDLY) or 48/14	1	0	0
SGR1...5/5	Pickup signal from element 50P	0	0	1

Switch	Function	Default setting		
		SGR1...SGR2	SGR3	SGR4...SGR5
SGR1...5/6	Trip signal from element 50P	1	0	0
SGR1...5/7	Pickup signal from element 37	0	0	1
SGR1...5/8	Trip signal from element 37	1	0	0
SGR1...5/9	Pickup signal from element 51N	0	0	1
SGR1...5/10	Trip signal from element 51N	1	0	0
SGR1...5/11	Pickup signal from element 46	0	0	1
SGR1...5/12	Trip signal from element 46	1	0	0
SGR1...5/13	Pickup signal from element 46R	1	0	0
SGR1...5/14	Motor start-up signal	0	0	1
SGR1...5/15	External trip signal	0	0	0
SGR1...5/16	Alarm signal from element 49/38-1	0	0	0
SGR1...5/17	Trip signal from element 49/38-1	0	0	0
SGR1...5/18	Alarm signal from element 49/38-2	0	0	0
SGR1...5/19	Trip signal from element 49/38-2	0	0	0
ΣSGR1...5		6826	0	9557



If the restart disable signal has been routed to PO3, SGR3 will be overridden.

SGL1...SGL8

The signals are routed to LED1 with the switches of switchgroup SGL1, to LED2 with those of SGL2, and so forth.

Table 5.1.4.12-9 SGL1...SGL8

Switch	Function	Default setting		
		SGL1	SGL2	SGL3...8
SGL1...8/1	Alarm signal from element 49	0	0	0
SGL1...8/2	Trip signal from element 49	0	0	0
SGL1...8/3	Restart disable signal	1	0	0
SGL1...8/4	Motor start up signal	0	1	0
SGL1...8/5	Trip signal from element (48/14 PICKUP) ² x (48/14 TDLY) or 48/14	0	0	0
SGL1...8/6	Trip signal from element 50P	0	0	0
SGL1...8/7	Trip signal from element 37	0	0	0
SGL1...8/8	Trip signal from element 51N	0	0	0
SGL1...8/9	Trip signal from element 46	0	0	0
SGL1...8/10	Trip signal from element 46R	0	0	0
SGL1...8/11	Emergency start signal	0	0	0
SGL1...8/12	DI1 signal	0	0	0

Switch	Function	Default setting		
		SGL1	SGL2	SGL3...8
SGL1...8/13	DI2 signal	0	0	0
SGL1...8/14	DI3 signal	0	0	0
SGL1...8/15	DI4 signal	0	0	0
SGL1...8/16	DI5 signal	0	0	0
SGL1...8/17	Alarm signal from element 49/38-1	0	0	0
SGL1...8/18	Trip signal from element 49/38-1	0	0	0
SGL1...8/19	Alarm signal from element 49/38-2	0	0	0
SGL1...8/20	Trip signal from element 49/38-2	0	0	0
SGL1...8/21	Trip signal from CBFAIL	0	0	0
SGL1...8/22	Disturbance recorder triggered	0	0	0
Σ SGL1...8		4	8	0

New trip target timer

The new trip target timer can be configured to allow a second trip target on the LCD. When several protection elements trip, the first trip target will be displayed until the time, as specified by the `NEW TRIP IND.` setting value, has expired. After this, a new trip target can displace the old one. The basic protection functions are not affected by the `NEW TRIP IND.` setting.

Table 5.1.4.12.-10 New trip target timer

Setting	Description	Setting range	Default setting
New trip target	New trip target timer in minutes	0...998	60
	No new trip target allowed until the previous one has been manually cleared	999	

Non-volatile memory settings

The table below presents data which can be configured to be stored in the non-volatile memory. All of the functions mentioned below can be selected separately with switches 1...6 either via the HMI or the SPA bus.

Table 5.1.4.12.-11 Memory settings

Setting	Switch	Function	Default setting
Non-volatile memory settings	1	<ul style="list-style-type: none"> 0 = operation target messages and LEDs will be cleared 1 = operation target messages and LEDs will be retained^{a)} 	1
	2	<ul style="list-style-type: none"> 1 = number of motor start ups will be retained^{a)} 	1
	3	<ul style="list-style-type: none"> 1 = disturbance recorder data will be retained^{a)} 	1
	4	<ul style="list-style-type: none"> 1 = event codes will be retained^{a)} 	1
	5	<ul style="list-style-type: none"> 1 = recorded data and information on the number of pickup of the protection elements will be retained^{a)} 	1
	6	<ul style="list-style-type: none"> 1 = the real-time clock will be running also during loss of auxiliary voltage^{a)} 	1
	Checksum		

^{a)} The prerequisite is that the battery has been inserted and is charged.



When all switches have been set to zero, the battery supervision is disabled.

5.1.4.13.

Technical data on protection functions

Table 5.1.4.13.-1 Element 49

Feature	Value
Set safe stall time, t_{6x}	2.0...120 s ^{a)}
Set ambient temperature, T_{amb}	0...70°C
Set restart disable level, 49 RESTDIS	20...80%
Set prior alarm level, 49 ALARM	50...100%
Trip level	100%
Time constant dial, K_c	1...64
Weighting factor, p	20...100%
Operate time accuracy	
<ul style="list-style-type: none"> >1.2 x FLA 	±5% of the set operate time or ±1 s

^{a)} The setting step is 0.5.

Table 5.1.4.13.-2 Element 48/14

Feature	Value
Set pickup 48/14 value, • at definite-time characteristic	1.00...10.0 x FLA
Pickup time, typical	55 ms
Time/current characteristic • definite-time operate time, 48/14 TDLY	0.30...80.0 s
Resetting time, typical/maximum	35/50 ms
Retardation time	30 ms
Drop-off/pick-up ratio, typical	0.96
Operate time accuracy at definite time characteristic	±2% of the set operate time or ±25 ms
Operation accuracy	±3% of the set pickup value



Elements (48/14 PICKUP)² x (48/14 TDLY) and 48/14 cannot be used concurrently.

Table 5.1.4.13.-3 Element (48/14 PICKUP)² x (48/14 TDLY)

Feature	Value
Set start-up current for motor, 48/14	1.00...10.0 x FLA
Pickup time, typical • at pickup criterion $I_p > 48/14 \text{ PICKUP}$	100 ms
Set start-up time for motor, 48/14 TDLY	0.30...80.0 s
Resetting time, typical/maximum	180/250 ms
Drop-off/pick-up ratio, typical • at pickup criterion	0.96
Operation accuracy	±10% of the calculated operate time ±0.2 s
Shortest possible operate time	300 ms



Elements (48/14 PICKUP)² x (48/14 TDLY) and 48/14 cannot be used concurrently.

Table 5.1.4.13.-4 Element 50P

Feature	Value
Set pickup value, 50P • at definite-time characteristic	0.50...20.0 x FLA
Pickup time, typical	50 ms
Time/current characteristic • definite time operate time, 59P-1 TDLY	0.05...30.0 s

Feature	Value
Resetting time, typical/maximum	40/50 ms
Retardation time	30 ms
Drop-off/pick-up ratio, typical	0.96
Operate time accuracy at definite-time characteristic	±2% of the set operate time or ±25 ms
Operation accuracy	±3% of the set pickup value

Table 5.1.4.13-5 Element 37

Feature	Value
Set pickup value, 51P	
• at definite-time characteristic	30...80% FLA
pickup time, typical	300 ms
Time/current characteristic	
• definite time operate time, 27P-1 TDLY	2...600 s
Resetting time, typical/maximum	300/350 ms
Drop-off/pick-up ratio, typical	1.1
Disable of 37	<12% FLA
Operate time accuracy at	
• definite-time characteristic	±3% of the set operate time or 100 ms
Operation accuracy	±3% of the set pickup value or +0.5% FLA

Table 5.1.4.13-6 Element 51N

Feature	Value
Set pickup value, 51N	
• at definite-time characteristic	1.0...100% I _n CT
Pickup time, typical	50 ms
Time/current characteristic	
• definite time operate time, 51N TDLY	0.05...300 s
Resetting time, typical/maximum	40/50 ms
Retardation time	30 ms
Drop-off/pick-up ratio, typical	0.96
Operate time accuracy at definite-time characteristic	±2% of the set operate time or ±25 ms
Operation accuracy	
• 1.0...10.0% I _n CT	±5% of the set pickup value
• 10.0...100% I _n CT	±3% of the set pickup value

Table 5.1.4.13-7 Element 46

Feature	Value
Set pickup value, 46	
• at IDMT characteristic	0.10...0.50 x FLA
Pickup time, typical	100 ms
Time/current characteristic	
• IDMT time constant, 46 TDIAL	5...100
Resetting time, typical/maximum	130/200 ms

Feature	Value
Drop-off/pick-up ratio, typical	0.95
Operate time accuracy	
• 46 PICKUP + 0.065...4.0 x FLA	±5% of the calculated operate time or ±100 ms
Operation accuracy	±5% of the set pickup value
Disable of 46	$I < 0.12 \times \text{FLA}$ or $I > 4.0 \times \text{FLA}$

Table 5.1.4.13.-8 Element 46R

Feature	Value
Trip value	NPS ≥75% of the maximum phase current
Time/current characteristic	
• definite time operate time	220 ms ±50 ms
Resetting time, typical	100...200 ms
Drop-off/pick-up ratio, typical	0.95

Table 5.1.4.13.-9 Element 66

Feature	Value
Set restart disable value, 66	5...500 s
Countdown rate of start-up time counter, 66 COOL/Δt	2...250 s/h

Table 5.1.4.13.-10 Elements 49/38-1 and 49/38-2

Feature	Value
Operate time accuracy at definite-time characteristic	±3% of the set operate time or 200 ms ^{a)}
RTD sensors	
Set alarm value, RTD1...6A	0...200°C
Operate time, RTD1...6A TDLY	1...100 s
Set trip value, RTD1...6T	0...200°C
Operate time, RTD1...6T TDLY	1...100 s
Hysteresis	5°C
Operation accuracy	±1°C (±3°C for Cu10)
Thermistors	
Set trip value, PTC1 and PTC2	0.1...15.0 kΩ
Operate time	2 s
Operation accuracy	±1% of the setting range

^{a)} Note the response time of the RTD card (<8 s).

Table 5.1.4.13.-11 CBFAIL

Feature	Value
Set operate time	0.10...60.0 s
Phase-current threshold for external triggering of the CBFAIL	
• pick-up/drop-off	0.13/0.11 x FLA



The accuracies apply only when the FLA secondary scaling factor has been set to 1.

5.1.5. Trip-circuit supervision

The trip-circuit supervision (TCS) detects open circuits, both when the circuit breaker is open and closed, and trip-circuit supply failure.

The trip-circuit supervision includes:

- Current limiter including the necessary hardware
- Software-based function in the self-supervision system

The trip-circuit supervision is based on a constant current injection principle: by applying an external voltage, a constant current is forced to flow through the external trip circuit. If the resistance of the trip circuit exceeds a certain limit for more than 21 seconds, due to oxidation or a bad contact, for instance, the trip-circuit supervision is activated and a warning appears on the LCD together with a fault code. The warning signal from the trip-circuit supervision can also be routed to SO2 by setting switch SGF1/8 to 1.

Under normal operating conditions, the applied external voltage is divided between the relay’s internal circuit and the external trip circuit so that at least 20 V remains over the relay’s internal circuit. If the external trip circuit’s resistance is too high or the internal circuit’s too low, due to welded relay contacts, for instance, the voltage over the relay’s internal circuit falls below 20 V (15...20 V), which activates the trip-circuit supervision.

The operation condition is:

$$U_c - (R_{ext} + R_{int} + R_s) \times I_{inj} \geq 20 \text{ V ac/dc} \tag{3}$$

- U_c = operating voltage over the supervised trip circuit
- I_{inj} = current flowing through the trip circuit, ~1.5 mA
- R_{ext} = external shunt resistor
- R_{int} = internal shunt resistor, 1 kΩ
- R_s = trip coil resistance

The external shunt resistor is used to enable trip-circuit supervision also when the circuit breaker is open.

The resistance of the external shunt resistor is to be calculated so that it does not cause malfunction of the trip-circuit supervision or affect the operation of the trip coil. Too high resistance causes too high voltage drop, which in turn results in the operation conditions not being fulfilled, whereas too low resistance may cause faulty operation of the trip coil.

The following values are recommended for the external resistor, R_{ext} :

Table 5.1.5.-1 Recommended values for R_{ext}

Operating voltage, U_c	Shunt resistor R_{ext}
48 V DC	1.2 k Ω , 5 W
60 V DC	5.6 k Ω , 5 W
110 V DC	22 k Ω , 5 W
220 V DC	33 k Ω , 5 W

The circuit breaker is to be provided with two external contacts, one opening and one closing contact. The closing contact is to be connected in parallel with the external shunt resistor, which enables trip-circuit supervision when the circuit breaker is closed. The opening contact, on the contrary, is to be connected in series with the external shunt resistor, which enables trip-circuit supervision when the circuit breaker is open; see Fig. 5.1.5.-1.

Trip-circuit supervision can be selected either via the HMI or with SPA parameter V113.

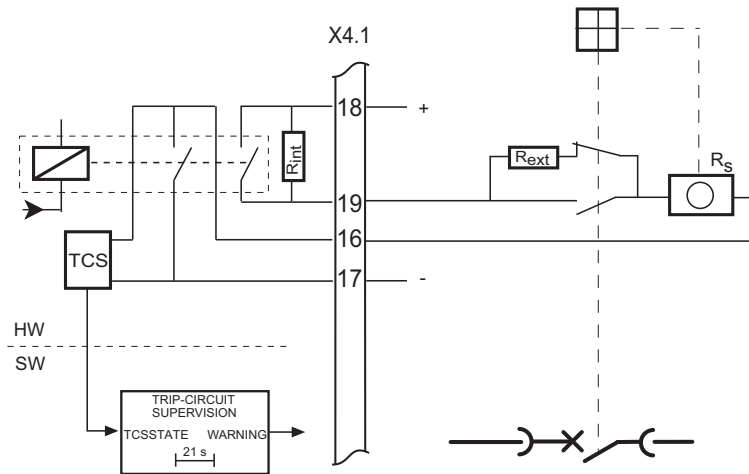

A050513

Fig. 5.1.5.-1 Connecting the trip-circuit supervision using two external contacts and the external resistor in the trip circuit

5.1.6. Target LEDs and operation target messages

The operation of the relay can be monitored via the HMI by means of LED targets and text messages on the LCD. On the front panel of the relay there are three target LEDs with fixed functionality:

- Green target LED (ready)
- Yellow target LED (pickup/alarm)
- Red target LED (trip)

In addition, there are eight programmable LEDs and an target LED for front communication. Refer to the Operator's Manual for a more thorough presentation.

The target messages on the LCD have a certain priority order. If different types of targets are activated simultaneously, the message with the highest priority appears on the LCD.

The priority order of the operation target messages:

1. CBFAIL
2. Trip
3. Pickup/Alarm
4. Restart disable
 - 4.1. Thermal protection
 - 4.2. Cumulative start-up time counter
 - 4.3. External restart disable

5.1.7. Motor running time counter

The motor running time counter provides history data since last commissioning. The counter counts the total number of motor running hours and is incremented when one or several phase currents have exceeded twelve per cent of the FLA of the motor for 100 running hours. The running time is stored in the EEPROM. The counter can be read via the HMI but changed only via parameter V53.



Writing to parameter V53 will reset the number of motor start ups.

5.1.8. Demand values

The relay provides three different kinds of demand values.

The first value shows the average current of all three phases measured during one minute. The value is updated once a minute.

The second value shows the average current during an adjustable time range, ranging from 0 to 999 minutes, with an accuracy of one minute. This value is updated at the expiration of each time range.

The third value shows the highest one-minute average current value measured during the previous time range. However, if the time range is set to zero, only the one-minute and the maximum value is shown. The maximum value is the highest one-minute mean value since the last reset.

The demand values can be set to zero by resetting the relay or through communication using a V parameter. The demand values are also reset if V105 is changed.

5.1.9. Commissioning tests

The following two product functions can be used during the commissioning of the relay: function test and digital input test.

The function test is used for testing the configuration as well as the connections from the relay. By selecting this test, the internal signals from the protection elements, the motor start-up signal, the external trip signal and the IRF function can be activated one by one. Provided that the signals have been set to be routed to the output contacts (PO1...PO3 and SO1 and SO2) with the switches of SGR1...SGR5, the output contacts are activated and their corresponding event codes are generated when the test is run. However, activation of the internal signals from the protection elements, the motor start-up signal, the external trip signal and the IRF function do not generate an event code.

The digital input test is used for testing the connections to the relay. The state of the digital inputs can be monitored via the HMI.

Refer to the Operator's Manual for instructions on how to perform the tests.

5.1.10. Disturbance recorder

5.1.10.1. Function

The relay features an integrated disturbance recorder which continuously captures the curve forms of the currents as well as the status of both internal signals and digital input signals and stores these in the memory.

Triggering of the recorder generates an event code. After the recorder has been triggered, it continues to record data for a pre-defined post-triggering time. An asterisk is shown on the LCD on completion of the recording. The status of the recording can also be viewed using SPA parameter V246.

As soon as the recorder has been triggered and the recording has finished, the recording can be uploaded and analyzed by means of a PC provided with a special program.

5.1.10.2. Disturbance recorder data

One recording contains data from the four analog channels and up to eight digital channels. The analog channels, whose data is stored either as RMS curves or as instantaneous measured values, are the measured by the relay. The digital channels, referred to as digital signals, are pickup and trip signals from the protection elements and the digital input signals linked to the relay.

The user can select up to eight digital signals to be recorded. If more than eight signals are selected, the first eight signals are stored, beginning with the internal signals followed by the digital input signals.

The digital signals to be stored are selected with parameters V238 and V243; see Table 5.1.15.-5 and Table 5.1.15.-6.

The recording length varies according to the selected sampling frequency. The RMS curve is recorded by selecting the sampling frequency to be the same as the nominal frequency of the relay. The sampling frequency is selected with SPA parameter M15; see the table below for details.

Table 5.1.10.2.-1 Sampling frequency

Nominal frequency Hz	Sampling frequency Hz	Cycles
50	800	250
	400	500
	50 ^{a)}	4000
60	960	250
	480	500
	60 ^{a)}	4000

^{a)} RMS curve.

Recording length:

$$[s] = \frac{\text{Cycles}}{\text{Nominal frequency [Hz]}} \tag{4}$$

Changing the setting values of parameters M15, V238 and V243 is allowed only when the recorder is not triggered.

The post-triggering recording length defines the time during which the recorder continues to store data after it has been triggered. The length can be changed with SPA parameter V240. If the post-triggering recording length is defined to be the same as the total recording length, no data stored prior to the triggering is retained in the memory. By the time the post-triggering recording finishes, a complete recording is created.

Triggering of the recorder immediately after it has been cleared or the auxiliary voltage connected may result in a shortened total recording length. Disconnection of the auxiliary voltage after the recorder has been triggered, but before the recording has finished, on the other hand, may result in a shortened post-triggering recording length. This, however, does not affect the total recording length.

At a power reset, triggered recorder data is retained in the memory provided that it has been defined non-volatile.

5.1.10.3. Control and target of disturbance recorder status

It is possible to control and monitor the recording status of the disturbance recorder by writing to and reading SPA parameters M1, M2 and V246. Reading SPA parameter V246 returns either the value 0 or 1, indicating whether the recorder has not been triggered or triggered and ready to be uploaded. Event code E31 is generated the moment the disturbance recorder is triggered. If the recorder is ready to be uploaded, this is also indicated by an asterisk shown in the lower right-hand corner of the LCD when it is in the idle mode. Target can also be routed to programmable LEDs.

Writing the value 1 to SPA parameter M2 clears the recorder memory and enables the triggering of the recorder. Recorder data can be cleared by performing a master reset, that is, clearing targets and memorized values and unlatching output contacts.

Writing the value 2 to SPA parameter V246 restarts the unloading process by setting the time stamp and the first data ready to be read.

5.1.10.4. Triggering

The user can select one or several internal or digital input signals to trigger the disturbance recorder, either on the rising or falling edge of the signal(s). Triggering on the rising edge means that the post-triggering recording sequence starts when the signal is activated. Correspondingly, triggering on the falling edge means that the post-triggering recording sequence starts when the active signal is reset.

The trigger signal(s) and the edge are selected with SPA parameters V236...V237 and V241...V242; see Table 5.1.15.-5 and Table 5.1.15.-6. The recorder can also be triggered manually with SPA parameter M1.

Triggering of the disturbance recorder is only possible if the recorder is not already triggered.

5.1.10.5. Settings and unloading

The setting parameters for the disturbance recorder are V parameters V236...V238, V240...V243 and V246, and M parameters M15, M18, M20 and M80...M83.

Unloading correct information from the recorder requires that M80 and M83 have been set. Unloading is done by using a PC application. The uploaded recorder data is stored in separate files defined by the comtrade® format.

5.1.10.6. Event code of the disturbance recorder

The disturbance recorder generates an event code on triggering (E31) and clearing (E32) the recorder. The event mask is determined using SPA parameter V155.

5.1.11. Recorded data of the last events

The relay records up to five events. This enables the user to analyze the last five fault conditions in the electrical power network. Each event includes the measured currents, pickup durations and time stamp, for instance. Additionally, information on the number of pickups of the elements, trips and auto-reclose shots is provided.

Recorded data is non-volatile by default, provided that the battery has been inserted and is charged. A master reset, that is, clearing of targets and memorized values and unlatching of output contacts, erases the contents of the stored events and the number of pickups of the elements.



The number of trips and auto-reclose shots is stored in the non-volatile memory (EEPROM) and is thereby not cleared when performing a master reset. The number of trips can be erased by entering the value 1 and the number of auto-reclose shots by entering the value 2 into parameter V166.

The relay collects data during fault conditions. When all pickup or thermal alarm signals have been reset or an element trips, the collected data and time stamp is stored as EVENT1 and the previously stored events move one step forward. When a sixth event is stored, the oldest event is cleared.

Table 5.1.11.-1 Recorded data

REGISTER	Data description
EVENT1	<ul style="list-style-type: none"> Phase currents I_a, I_b, I_c and the NPS current as a multiple of the full load current (FLA) of the motor. The ground fault current, I_n, as a percentage of the rated current of the CT used. When an element generates a pickup or an alarm signal, or when a motor start up ends, the maximum currents during the pickup period will be stored. When an element trips, the values at the time of the trip will be stored. Thermal stress value, $I_2 \times t$, as a percentage of the set reference value, $(48/14 \text{ PICKUP})^2 \times (48/14 \text{ TDLY})$. If start-up supervision based on thermal stress calculation has been selected and the pickup criteria for the element have been met, the maximum calculated thermal stress value will be stored. The value 100% indicates that the calculated thermal stress has exceeded the set reference value. Number of motor start ups. The number indicates the motor start up during which the event was stored and provides history data since last commissioning. Writing to parameter V53 will reset the number of motor start ups. Thermal level, as a percentage of the maximum thermal level of the motor, at activation of a pickup, alarm or motor start-up signal. The maximum thermal level during the time the pickup, alarm or motor startup signal was active, as a percentage of the maximum thermal level of the motor, or in case of a trip, the thermal level, as a percentage of the maximum thermal level of the motor, at activation of a trip signal. The temperatures from inputs RTD1...6 (optional) and the resistance values of thermistors 1 and 2 (optional). When an element generates a pickup or an alarm signal, or when a motor start up ends, the maximum temperature(s) and thermistor resistance value(s) during the pick-up period will be stored. When an element trips, the temperatures and resistance values at the time of trip will be stored. Duration of the last pickups of elements 48/14, 50P, 46, 51N and 37, and of the last alarms and trips of elements 49/38-1 (optional) and 49/38-2 (optional), expressed as a percentage of the set or calculated operate time. The timing will start when an element picks up. The elapsed operate times of elements 49/38-1 and 49/38-2 for the RTD input which has been activated the longest in their respective groups. A value other than zero indicates that the corresponding element has picked up whereas the value 100% indicates that the operate time of the element has elapsed, i.e. the element has tripped. If the operate time of an element has elapsed but the element is blocked, the value will be 99% of the set or calculated operate time. Time stamp for the event. The time when the collected data was stored. The time stamp is displayed in two registers, one including the date expressed as yy-mm-dd, and the other including the time expressed as HH.MM; SS.sss.
EVENT 2	Same as EVENT 1.
EVENT 3	Same as EVENT 1.
EVENT 4	Same as EVENT 1.
EVENT 5	Same as EVENT 1.
Number of pickups	The number of times each protection element, 48/14, 50P 46, 51N and 37, has picked up, counting up to 999.
Motor start up	Motor start-up time and maximum motor start-up current

5.1.12. Communication ports

The relay is provided with an optical communication port (infrared) on the front panel. Rear communication is optional and requires a communication module, which can be provided with either a plastic fibre-optic, combined fibre-optic (plastic and glass) or RS-485 connection. The relay is connected to an automation system via the rear connection. The optional rear communication module allows the use of either the SPA bus, IEC 60870-5-103 or Modbus communication protocol.

For further information on optional rear communication module connections, refer to Section 5.2.2. Serial communication connections.



A051551

Fig. 5.1.12.-1 Communication port

1) Front connection for local communication

The relay is connected to a PC used for local parameterization via the infrared port on the front panel. The front connection allows the use of the SPA bus protocol only.

The optical front connection galvanically isolates the PC from the relay. The front connection can be used in two different ways: wirelessly using a PC compatible to the IrDA[®], Standard specifications or using a specific front communication cable (refer to Section 7. Ordering information). The cable is connected to the serial RS-232 port of the PC. The optical element of the cable is powered by RS-232 control signals. The cable has a fixed baud rate of 9.6 kbps.

The following serial communication parameters are to be set for RS-232:

- Number of data bits: 7
- Number of stop bits: 1
- Parity: even
- Baud rate: 9.6 kbps

Relay data such as events, setting values and all input data and memorized values can be read via the front communication port.

When setting values are altered via the front communication port, the relay checks that the entered parameter values are within the permitted setting range. If an entered value is too high or too low, the setting value remains unchanged.

The relay has a counter which can be accessed via `CONFIGURATION \COMMUNICATION` in the HMI menu. The counter value is set to zero when the relay receives a valid message.

5.1.13.

IEC 60870-5-103 remote communication protocol

The relay supports the IEC 60870-5-103 remote communication protocol in the unbalanced transmission mode. The IEC 60870-5-103 protocol is used to transfer measurand and status data from the slave to the master. However, the IEC 60870-5-103 protocol cannot be used to transfer disturbance recorder data.

The IEC 60870-5-103 protocol can be used only through the rear connection of the relay on the optional communication module. Connecting the relay to a fibre-optic communication bus requires a fibre-optic communication module. The line-idle state of the fibre-optic communication module can be selected either via the HMI or the SPA bus. According to the IEC 60870-5-103 standard, the line-idle state is “light on”. To ensure communication, the line-idle state should be the same for both the master and the slave device. The connection topology can be selected to be either loop or star, the default being loop, and either via the HMI or the SPA bus. The selected line-idle state and connection topology apply irrespective of which rear communication protocol is active.

The relay uses the SPA bus protocol as default when the optional communication module is in use. The protocol selection is memorized and is therefore always activated when the rear connection is in use. The baud rate can be selected either via the HMI or the SPA bus. According to the IEC 60870-5-103 standard, the baud rate is 9.6 kbps. When the IEC 60870-5-103 protocol is active, event masks are not in use. Consequently, all events in the selected configuration set are included in the event reporting.

The relay is provided with two different selectable configuration sets, of which configuration set 1 is used by default.

Configuration set 1 is intended to be used when the optional RTD module is not installed. Configuration set 2 includes additional information, for example temperature protection events and digital input events 3...5, provided that the optional RTD module is installed.

Function type and information number are mapped into configuration sets according to the IEC 60870-5-103 standard to the extent that these have been defined by the standard. If not defined by the standard, the type of function and/or the information number are/is mapped into a private range.

The tables below indicate the information mapping of the corresponding configuration sets. The column GI indicates whether the status of the specified information object is transmitted within the general interrogation cycle. The relative

time in messages with the type identification 2 is calculated as a time difference between the occurred event and the event specified in the column Relative time. The measurand multiplied by the normalize factor is proportional to the rated value. Therefore, the maximum value of each measurand is the normalize factor multiplied by the rated value.

Table 5.1.13.-1 Information mapping of configuration set 1 and 2

Event reason	Event code	Configuration set 1	Configuration set 2	Function type	Information number	GI	Relative time	Type identification
Emergency start Activated/Reset	0E5/ 0E6	X	X	11	31	X	-	1
Disturbance recorder Triggered/Cleared	0E31/ 0E32	X	X	178	100	-	-	1
HMI Setting password Opened/Closed	0E33/ 0E34	X	X	178	101	-	-	1
HMI Communication password Opened/Closed	0E35/ 0E36	X	X	178	102	-	-	1
Motor start up Begins/Ends	1E1/ 1E2	X	X	178	84	X	1E1	2
49 Pickup/Reset	1E3/ 1E4	X	X	184	84	X	1E3	2
49 Alarm/Reset	1E5/ 1E6	X	X	184	11	X	1E3	2
49 Trip/Reset	1E7/ 1E8	X	X	184	90	-	1E3	2
49 Restart Disable/Reset	1E9/ 1E10	X	X	184	30	X	1E3	2
66 Restart Disable/Reset	1E11/ 1E12	X	X	178	30	X	-	1
Restart Disable/Reset	1E13/ 1E14	X	X	11	30	X	-	1
(48/14 PICKUP) ² x (48/14 TDLY)/(48/14) Pickup/Reset	1E15/ 1E16	X	X	160	84	X	1E15	2
(48/14 PICKUP) ² x (48/14 TDLY)/(48/14) Trip/Reset	1E17/ 1E18	X	X	160 ^{a)} 178	90	-	1E15	2
50P Pickup/Reset	1E19/ 1E20	X	X	162	94	X	1E19	2
50P Trip/Reset	1E21/ 1E22	X	X	160	91	-	1E19	2
37 Pickup/Reset	1E23/ 1E24	X	X	20	84	X	1E23	2
37 Trip/Reset	1E25/ 1E26	X	X	20	90	-	1E23	2

Technical Reference Manual - ANSI Version

Event reason	Event code	Configuration set 1	Configuration set 2	Function type	Information number	GI	Relative time	Type identification
51N Pickup/Reset	1E27/ 1E28	X	X	160	67	X	1E27	2
51N Trip/Reset	1E29/ 1E30	X	X	160	92	-	1E27	2
46 Pickup/Reset	1E31/ 1E32	X	X	21	84	X	1E31	2
46 Trip/Reset	1E33/ 1E34	X	X	21	90	-	1E31	2
46R Trip/Reset	1E35/ 1E36	X	X	22	90	-	1E1	2
CBFAIL Activated/Reset	1E37/ 1E38	X	X	160	85	-	-	1
PO1 Activated/Reset	2E1/ 2E2	X	X	251	27	X	-	1
PO2 Activated/Reset	2E3/ 2E4	X	X	251	28	X	-	1
PO3 Activated/Reset	2E5/ 2E6	X	X	251	29	X	-	1
SO1 Activated/Reset	2E7/ 2E8	X	X	251	30	X	-	1
SO2 Activated/Reset	2E9/ 2E10	X	X	251	31	X	-	1
DI1 Activated/Deactivated	2E11/ 2E12	X	X	249	231	X	-	1
DI2 Activated/Deactivated	2E13/ 2E14	X	X	249	232	X	-	1
DI3 Activated/Deactivated	2E15/ 2E16	-	X	249	233	X	-	1
DI4 Activated/Deactivated	2E17/ 2E18	-	X	249	234	X	-	1
DI5 Activated/Deactivated	2E19/ 2E20	-	X	249	235	X	-	1
49/38-1 Alarm/Reset	2E21/ 2E22	-	X	210	11	X	2E21	2
49/38-1 Trip/Reset	2E23/ 2E24	-	X	210	21	-	2E23	2
49/38-2 Alarm/Reset	2E25/ 2E26	-	X	211	11	X	2E25	2
49/38-2 Trip/Reset	2E27/ 2E28		X	211	21	-	2E27	2

^{a)}) When start-up supervision based on thermal stress calculation has been selected (SGF3/6=0), the function type in brackets will be used.

Table 5.1.13.-2 Information mapping of configuration set 1 and 2

Measurand	Normalize factor	Rated value	Configuration set 1	Configuration set 2	Function type	Information number	Type identification
Current I _a	2.4	I _n (CT)	X	X	135	140	9
Current I _b	2.4	I _n (CT)	X	X			
Current I _c	2.4	I _n (CT)	X	X			
Current I _n	2.4	I _n (CT)	X	X			

5.1.14.

Modbus remote communication protocol

The master/slave protocol Modbus was first introduced by Modicon Inc. and is widely accepted as a communication standard for industrial device controllers and PLCs. For the protocol definition, refer to Section 1.4. Product documentation.

The implementation of the Modbus protocol in the relay supports both the RTU and the ASCII link mode. Both the link mode and the line setting parameters are user-configurable. The character codings of the link modes follow the protocol definition. The RTU character format is presented in Table 5.1.14.-1 and the ASCII character format in Table 5.1.14.-2:

Table 5.1.14.-1 RTU character format

Coding system	8-bit binary
Bits per character	1 pickup bit 8 data bits, the least significant bit is sent first 1 bit for even/odd parity; no bit if parity is not used 1 stop bit if parity is used; 2 stop bits if parity is not used

Table 5.1.14.-2 ASCII character format

Coding system	Two ASCII characters representing a hexadecimal number
Bits per character	1 pickup bit 7 data bits, the least significant bit is sent first 1 bit for even/odd parity; no bit if parity is not used 1 stop bit if parity is used; 2 stop bits if parity is not used



The turnaround time (response time) of the relay depends on the amount of data requested in a query. Therefore, the turnaround time can vary between approximately 10 and 70 ms. However, a turnaround timeout no lower than 100 ms is recommended for the Modbus master.



The data address range in the Modbus network follows the protocol definition and starts from 0.3. Consequently, the data addresses in Table 5.1.14.1.-5...Table 5.1.14.1.-13 are decreased by one when transferred over the network.



The Modbus data type digital input (DI) is commonly also referred to as 1X, coils as 0X, input register (IR) as 3X and holding register (HR) as 4X, of which the former is used here. Thus, HR 123, for instance, can also be referred to as register 400123.

5.1.14.1.

Profile of Modbus

The Modbus protocol (ASCII or RTU) is selected via the HMI and can be used only through the rear connection of the relay on the optional communication module. Modbus line settings, that is, parity, CRC byte order and baud rate, can be adjusted either via the HMI or the SPA bus.

The implementation of the Modbus protocol in REM610 supports the following functions:

Table 5.1.14.1.-1 Supported application functions

Function code	Function description
01	Read coil status Reads the status of discrete outputs.
02	Read digital input status Reads the status of discrete inputs.
03	Read holding registers Reads the contents of output registers.
04	Read input registers Reads the contents of input registers.
05	Force single coil Sets the status of a discrete output.
06	Preset single register Sets the value of a holding register.
08	Diagnostics Checks the communication system between the master and the slave.
15	Force multiple coils Sets the status of multiple discrete outputs.
16	Preset multiple registers Sets the value of multiple holding registers.
23	Read/write holding registers Exchanges holding registers in one query.

Table 5.1.14.1.-2 Supported diagnostic subfunctions

Code	Name	Description
00	Return query data	The data in the query data field is returned (looped back) in the response. The entire response is to be identical to the query.
01	Restart communication option	The slave's peripheral port is initialized and restarted and the communication event counters are cleared. Before this, a normal response will be sent provided that the port is not in the listen only mode. However, if the port is in the listen only mode, no response will be sent.
04	Force listen only mode	The slave is forced to enter the listen only mode for Modbus communication.
10	Clear counters and diagnostic register	All counters and the diagnostic register are cleared.
11	Return bus message count	The number of messages in the communications system detected by the slave since its last restart, clear counters operation or power up is returned in the response.
12	Return bus communication error count	The number of CRC errors encountered by the slave since its last restart, clear counters operation or power up is returned in the response.
13	Return bus exception error count	The number of Modbus exception responses sent by the slave since its last restart, clear counters operation or power up is returned in the response.
14	Return slave message count	The number of messages addressed to the slave or broadcast which the slave has processed since its last restart, clear counters operation or power up is returned in the response.
15	Return slave no response count	The number of messages addressed to the slave for which a response (neither a normal response nor an exception response) has not been sent since its last restart, clear counters operation or power up is returned in the response.
16	Return slave NACK response count	The number of messages addressed to the slave for which a NACK response has been sent is returned in the response.
18	Return bus character overrun count	The number of messages addressed to the slave for which it has not been able to send a response due to a character overrun since its last restart, clear counters operation or power up is returned in the response.



Sending other subfunction codes than those listed above cause an Illegal data value response.

The Modbus protocol provides the following diagnostic counters:

Table 5.1.14.1-3 Diagnostic counters

Name	Description
Bus message count	The number of messages in the communications system detected by the slave since its last pickup, clear counters operation or power up.
Bus communication error count	The number of CRC or LRC errors encountered by the slave since its last restart, clear counters operation or power up.
Bus exception error count	The number of Modbus exception responses sent by the slave since its last restart, clear counters operation or power up.
Slave message count	The number of messages addressed to the slave or broadcast which the slave has processed since its last restart, clear counters operation or power up.
Slave no response count	The number of messages addressed to the slave for which a response (neither a normal response nor an exception response) has not been sent since its last restart, clear counters operation or power up.
Slave NACK response count	The number of messages addressed to the slave for which a NACK response has been sent.
Bus character overrun count	The number of messages addressed to the slave for which it has not been able to send a response due to a character overrun since its last restart, clear counters operation or power up.

The following exception codes may be generated by the Modbus protocol:

Table 5.1.14.1-4 Possible exception codes

Code	Name	Description
01	Illegal function	The slave does not support the requested function.
02	Illegal data address	The slave does not support the data address or the number of items in the query is incorrect.
03	Illegal data value	A value contained in the query data field is out of range.
04	Slave device failure	An unrecoverable error has occurred while the slave was attempting to perform the requested task.



If an Illegal data value exception response is generated when attempting to preset multiple registers, the contents of the register to which an illegal value has been imposed and of the following registers is not changed. Registers which have already been preset are not restored.

User-defined registers

Reading of unwanted data in a data block wastes bandwidth and complicates data interpretation. For optimum efficiency in Modbus communication, data has therefore been organized into consecutive blocks. In addition, a set of programmable user-defined registers (UDR) has been defined in the holding register area.

The first sixteen holding registers, that is, HR1...16, are user-defined registers. The UDRs can be linked to any holding register, except for HR721...727, using SPA parameters 504V1...504V16. However, one UDR cannot be linked to another, that is, linking cannot be nested. Each parameter contains the address of the holding register to which the UDR is linked.

If a UDR is linked to a non-existent holding register, reading from the register fails and an `Illegal address exception` response is sent. Giving the link address the value 0 disables the UDR. If the master reads from a disabled UDR, the value 0 is returned.

The UDRs are mirrored in HR385...400.

Fault records

The data recorded during a fault sequence is called a fault record (FR). The slave stores the five latest fault records. When a sixth record is stored, the oldest record is deleted.

To read a fault record:

1. Write a preset single register command (function 06) to HR601 using a selection code as data value.
2. Read the selected fault record (function 04) from HR601, register count 33.

Alternatively, a fault record can be read using one command (function 17H) only.

Selection code 1: the master reads the oldest unread record

Status register 3 (HR403) informs whether there are unread fault records (see Fig. 5.1.14.1.-2). If there is one or several unread fault records, the master can read the contents using selection code 1.

The fault record contains a sequence number which makes it possible for the master to determine whether one or several unread fault records have been deleted due to overflow. The master compares the sequence number to that of the previously read fault record.

The slave keeps track of which fault record is currently the oldest unread. The master can continue reading fault records for as long as Status register 3 indicates that there are unread records.

- Special case 1: If there are no unread fault records, the contents of the last read record is returned. If the buffer is empty, however, the registers contain only zeros. This is the only time when sequence number zero appears.
- Special case 2: If the master tries to read the next unread fault record without entering selection code 1 again, the contents of the last read record will be returned.

Selection code 2: the master reads the oldest stored record

By resetting the read pointer using selection code 2, the master can read the oldest stored fault record. After this, the master can continue reading the following records using selection code 1, irrespective of whether they have been read before.



Resetting the read pointer does not affect the sequence number of the fault record.



A master reset, that is, clearing of targets and memorized values and unlatching of output contacts, clears the fault records, after which the sequence number starts from 1 again.

Event records

Modbus events are derived from SPA events. With a few exceptions, SPA events update binary points in the DI and the packed HR area. Simultaneously, a corresponding Modbus event record is generated. The event record contains the Modbus DI/CO data point address and the value to which the point has changed (0 or 1). SPA events lacking a corresponding DI/CO data point are shown as SPA channel and event code (informative event) in the event record. The maximum capacity of the Modbus event buffer is 99 events. The time stamp of Modbus events is extended to contain complete information, from date to millisecond.

To read an event record:

1. Write a preset single register command (function 06) to HR671 using a selection code as data value.
2. Read the selected fault record (function 04) from HR672, register count 8.

Alternatively, a fault record can be read using one command (function 23) only.

Selection code 1: reading the oldest unread record

Status register 3 (HR403) informs whether there are unread event records (see Fig. 5.1.14.1.-2). If there is one or several unread event records, the master can read the contents using selection code 1.

The event record contains a sequence number which makes it possible for the master to determine whether one or several unread event records have been deleted due to overflow by comparing it to the sequence number of the previously read event record.

The slave keeps track of which event record is currently the oldest unread. The master can continue reading event records for as long as Status register 3 indicates that there are unread records.

- Special case 1: If there are no unread event records, the contents of the last read record is returned. If the buffer is empty, however, the registers contain only zeros. This is the only time when sequence number zero appears.
- Special case 2: If the master tries to read the next unread event record without entering selection code 1 again, the contents of the last read record is returned.

Selection code 2: reading the oldest stored record

By resetting the read pointer using selection code 2, the master can read the oldest stored event record. After this, the master can continue reading the following records using selection code 1, irrespective of whether they have been read before.



Resetting the read pointer does not affect the sequence number of the event record.

Selection code -1...-99

With selection code -1...-99, the master can move backwards from the newest event as many events as defined by the selection code and read that specific event record. After this, the master can continue reading the following records using selection code 1, irrespective of whether they have been read before.

- Special case: If there is not as many events in the buffer as specified by the selection code, the oldest stored event is read.

Selection code 3

The Modbus event buffer is cleared with selection code 3. Clearing the buffer does not require any read operation to follow.

Digital inputs

As the master may not detect the state changes of all digital signals when scanning, an additional change detect (CD) target bit is created for every instantaneous target point; see the example below.

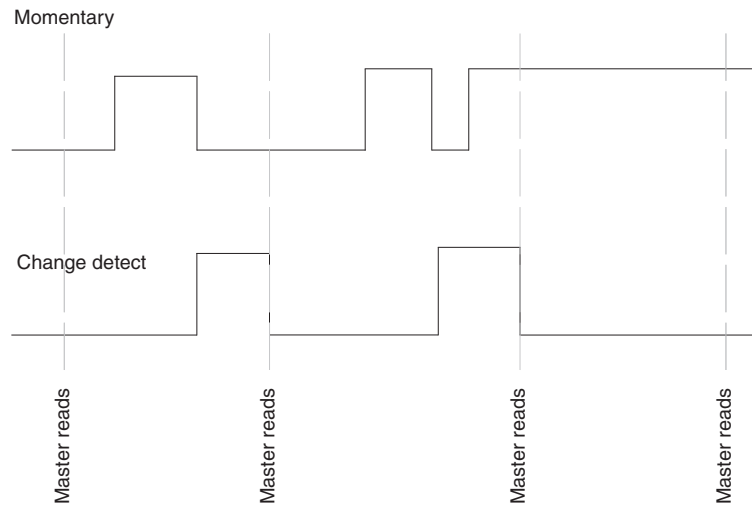

A040332

Fig. 5.1.14.1.-1 Change detection bit

If the instantaneous value of a target bit has changed two or more times since the master last read it, the CD bit is set to one. When the CD bit has been read, it is set to zero.

The instantaneous and the CD bit of a certain target point always occur as a pair in the Modbus memory map.

Modbus data mapping

There are two types of monitoring data: digital targets and measurands. For convenience and efficiency, the same data can be read from different data areas. Measurands and other 16-bit values can be read either from the IR or HR (read-only) area and digital target values from either the DI or coil (read-only) area. It is also possible to read the status of the DIs as packed 16-bit registers from both the IR and the HR area.

Consequently, all monitoring data can be read as consecutive blocks of data from the IR or HR area.

The register and bit addresses are presented in the tables below. Some register structures are presented in separate sections below.



The HR and IR values are unsigned 16-bit integers unless otherwise specified.

Table 5.1.14.1.-5 Mapping of Modbus data: user-defined registers

Description	HR/IR address (.bit)	DI/Coil bit address	Writeable	Value range	Comment
UDR 1	1 or 385				
UDR 2	2 or 386				
UDR 3	3 or 387				
UDR 4	4 or 388				
UDR 5	5 or 389				
UDR 6	6 or 390				
UDR 7	7 or 391				
UDR 8	8 or 392				
UDR 9	9 or 393				
UDR 10	10 or 394				
UDR 11	11 or 395				
UDR 12	12 or 396				
UDR 13	13 or 397				
UDR 14	14 or 398				
UDR 15	15 or 399				
UDR 16	16 or 400				

Table 5.1.14.1.-6 Mapping of Modbus data: status registers

Description	HR/IR address (.bit)	DI/Coil bit address	Writeable	Value range	Comment
Status register 1	401			IRF code	See Structure 1
Status register 2	402			Warning codes	See Structure 1
Status register 3	403				See Structure 1

Table 5.1.14.1.-7 Mapping of Modbus data: analog data

Description	HR/IR address (.bit)	DI/Coil bit address	Writeable	Value range	Comment
Phase current $I_a \times I_n$ (CT)	404			0...5000	0...50 x FLA
Phase current $I_b \times I_n$ (CT)	405			0...5000	0...50 x FLA
Phase current $I_c \times I_n$ (CT)	406			0...5000	0...50 x FLA
Ground-fault current $\times I_n$ (CT)	407			0...8000	0...800.0% I_n (CT)
NPS current	408			0...5000	0...50 x FLA
Temperature from RTD1	409			-40...999	°C (signed) ^{a)}
Temperature from RTD2	410			-40...999	°C (signed) ^{a)}
Temperature from RTD3	411			-40...999	°C (signed) ^{a)}
Temperature from RTD4	412			-40...999	°C (signed) ^{a)}
Temperature from RTD5	413			-40...999	°C (signed) ^{a)}
Temperature from RTD6	414			-40...999	°C (signed) ^{a)}
Thermistor 1, resistance value	415			0...200	0...20.0 kΩ ^{b)}
Thermistor 2, resistance value	416			0...200	0...20.0 kΩ ^{b)}

Table footnotes from previous page

a) If the input is out of operation or the optional RTD module has not been installed, the value -32768 will be returned.

b) If the input is out of operation or the optional RTD module has not been installed, the value 655 will be returned.

Table 5.1.14.1.-8 Mapping of Modbus data: digital data

Description	HR/IR address (.bit)	DI/Coil bit address	Writeable	Value range	Comment
Motor start up	417.00	1		0/1	1 = begins 0 = ends
Motor start up CD	417.01	2			
Pickup signal from element 49	417.02	3		0/1	1 = activated
Pickup signal from element 49 CD	417.03	4			
Alarm signal from element 49	417.04	5		0/1	1 = activated
Alarm signal from element 49 CD	417.05	6			
Trip signal from element 49	417.06	7		0/1	1 = activated
Trip signal from element 49 CD	417.07	8			
Restart disable signal from element 49	417.08	9		0/1	1 = activated
Restart disable signal from element 49 CD	417.09	10			
Restart disable signal from element 66	417.10	11		0/1	1 = activated
Restart disable signal from element 66 CD	417.11	12			
Restart disable	417.12	13		0/1	1 = activated ^{a)}
Restart disable CD	417.13	14			
Pickup signal from element (48/14 PICKUP) ² x (48/14 TDLY) or 48/14	417.14	15		0/1	1 = activated
Pickup signal from element (48/14 PICKUP) ² x (48/14 TDLY) or 48/14 CD	417.15	16			
Trip signal from element (48/14 PICKUP) ² x (48/14 TDLY) or 48/14	418.00	17		0/1	1 = activated
Trip signal from element (48/14 PICKUP) ² x (48/14 TDLY) or 48/14 CD	418.01	18			
Pickup signal from element 50P-1	418.02	19		0/1	1 = activated
Pickup signal from element 50P-1 CD	418.03	20			
Trip signal from element 50P-1	418.04	21		0/1	1 = activated
Trip signal from element 50P-1 CD	418.05	22			
Pickup signal from element 37	418.06	23		0/1	1 = activated
Pickup signal from element 37 CD	418.07	24			
Trip signal from element 37	418.08	25		0/1	1 = activated
Trip signal from element 37 CD	418.09	26			
Pickup signal from element 51N	418.10	27		0/1	1 = activated
Pickup signal from element 51N CD	418.11	28			
Trip signal from element 51N	418.12	29		0/1	1 = activated
Trip signal from element 51N CD	418.13	30			
Pickup signal from element 46	418.14	31		0/1	1 = activated
Pickup signal from element 46 CD	418.15	32			
Trip signal from element 46	419.00	33		0/1	1 = activated

Technical Reference Manual - ANSI Version

Description	HR/IR address (.bit)	DI/Coil bit address	Writeable	Value range	Comment
Trip signal from element 46 CD	419.01	34			
Trip signal from element 46R	419.02	35		0/1	1 = activated
Trip signal from element 46R CD	419.03	36			
CBFAIL	419.04	37		0/1	1 = activated
CBFAIL CD	419.05	38			
PO1	419.06	39		0/1	1 = activated
PO1 CD	419.07	40			
PO2	419.08	41		0/1	1 = activated
PO2 CD	419.09	42			
PO3	419.10	43		0/1	1 = activated
PO3 CD	419.11	44			
SO1	419.12	45		0/1	1 = activated
SO1 CD	419.13	46			
SO2	419.14	47		0/1	1 = activated
SO2 CD	419.15	48			
DI1	420.00	49		0/1	1 = activated
DI1 CD	420.01	50			
DI2	420.02	51		0/1	1 = activated
DI2 CD	420.03	52			
DI3	420.04	53		0/1	1 = activated
DI3 CD	420.05	54			
DI4	420.06	55		0/1	1 = activated
DI4 CD	420.07	56			
DI5	420.08	57		0/1	1 = activated
DI5 CD	420.09	58			
Alarm signal from element 49/38-1	420.10	59		0/1	1 = activated
Alarm signal from element 49/38-1 CD	420.11	60			
Trip signal from element 49/38-1	420.12	61		0/1	1 = activated
Trip signal from element 49/38-1 CD	420.13	62			
Alarm signal from element 49/38-2	420.14	63		0/1	1 = activated
Alarm signal from element 49/38-2 CD	420.15	64			
Trip signal from element 49/38-2	421.00	65		0/1	1 = activated
Trip signal from element 49/38-2 CD	421.01	66			
Disturbance recorder	421.02	67		0/1	1 = triggered 0 = cleared
Disturbance recorder CD	421.03	68			
HMI Setting password	421.04	69		0/1	1 = opened 0 = closed
HMI Setting password CD	421.05	70			
IRF	421.06	71		0/1	1 = activated
IRF CD	421.07	72			
Warning	421.08	73		0/1	1 = activated
Warning CD	421.09	74			

Description	HR/IR address (.bit)	DI/Coil bit address	Writeable	Value range	Comment
Emergency start	421.10	75		0/1	1 = activated
Emergency start CD	421.11	76			
HMI Communication password	421.12	77		0/1	1 = opened 0 = closed
HMI Communication password CD	421.13	78			

a) The thermal restart disable level is exceeded, the start-up time counter is full or the external restart disable signal is active.

Table 5.1.14.1.-9 Mapping of Modbus data: recorded data

Description	HR/IR address (.bit)	DI/Coil bit address	Writeable	Value range	Comment
Fault record	601...633				See Structure 2
Event record	671...679				See Structure 3

Table 5.1.14.1.-10 Mapping of Modbus data: relay identification

Description	HR/IR address (.bit)	DI/Coil bit address	Writeable	Value range	Comment
Type designation of the relay	701...708				ASCII chars, 2 chars/register

Table 5.1.14.1.-11 Mapping of Modbus data: real-time clock

Description	HR/IR address (.bit)	DI/Coil bit address	Writeable	Value range	Comment
Time reading and setting	721...727		W		See Structure 4

Table 5.1.14.1.-12 Mapping of Modbus data: additional analog data

Description	HR/IR address (.bit)	DI/Coil bit address	Writeable	Value range	Comment
Maximum phase current after motor start up	801			0...5000	0...50 x FLA
Maximum ground-fault current after motor start up	802			0...8000	0...800.0% I _n (CT)
Minimum phase current after motor start up	803			0...5000	0...50 x FLA ^{a)}
Minimum ground-fault current after motor start up	804			0...8000	0...800.0% I _n (CT) ^{b)}
One-minute demand value	805			0...5000	0...50 x FLA
Demand value during the specified time range	806			0...5000	0...50 x FLA
Maximum one-minute demand value during the specified time range	807			0...5000	0...50 x FLA
Thermal level	808			0...106	%
Cumulative start-up time counter	809			0...999	Seconds
Time to next possible motor start up	810			0...999	Minutes
Motor running time	811			0...999	x 100 h
Maximum phase current during motor start up	812			0...5000	0...50 x FLA
Element/phase which caused the trip	813			0...65535	See Table 5.1.15.-2

Description	HR/IR address (.bit)	DI/Coil bit address	Writeable	Value range	Comment
Trip target code	814			0...21	See Table 5.1.15.-2
Start-up time of the latest motor start up	815			0...240	Seconds
Number of pickups of element 48/14	816			0...999	Counter
Number of pickups of element 50P-1	817			0...999	Counter
Number of pickups of element 51N	818			0...999	Counter
Number of pickups of element 37	819			0...999	Counter
Number of pickups of element 46	820			0...999	Counter

a) During motor start up, the value 16383 will be returned, indicating that the current value is not available.
 b) During motor start up, the value 13107 will be returned, indicating that the current value is not available.

Table 5.1.14.1.-13 Mapping of Modbus data: control points

Description	HR/IR address (.bit)	DI/Coil bit address	Writeable	Value range	Comment
LED reset		501	W	1	1 = LED reset ^{a)}

a) Coil area, only writeable.

Structure 1

The status registers contain information on unread fault and event records, and relay status. The registers are arranged as in Fig. 5.1.14.1.-2 below.

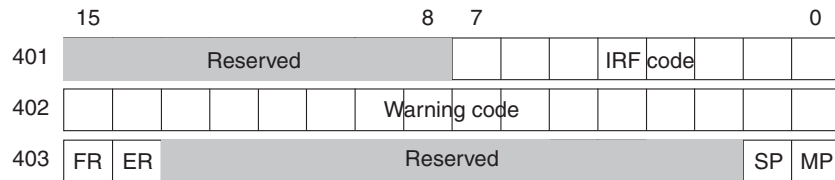

A040333

Fig. 5.1.14.1.-2 Status registers

When the value of the FR/ER bit is 1, there is one or several unread fault/event records. If time synchronization is realized via a digital input, either the SP (second-pulse) or MP (minute-pulse) bit will be activated.

Refer to Table 5.1.16.-1 for IRF codes and Table 5.1.16.-2 for warning codes.

Structure 2

This structure contains data recorded during a fault sequence. Refer to Fault records earlier in this section for the reading method.

Table 5.1.14.1.-14 Fault record

Address	Signal name	Range	Comment
601	Latest selection code ^{a)}	1...2	1 = read oldest unread record 2 = read oldest stored record
602	Sequence number	1...999	
603	Unread records left	0...6	
604	Time stamp of the recorded data, date		2 bytes: YY.MM
605	Time stamp of the recorded data, time		2 bytes: DD.HH
606	Time stamp of the recorded data, date and time		2 bytes: MM.SS
607	Time stamp of the recorded data, time	0...999	0...999 ms
608	Phase current I _a	0...5000	0...50 x FLA
609	Phase current I _b	0...5000	0...50 x FLA
610	Phase current I _c	0...5000	0...50 x FLA
611	Ground-fault current	0...8000	0...800.0%
612	NPS current	0...5000	0...50 x FLA
613	Thermal stress value	0...100	0...100%
614	Number of motor start ups	0...999	0...999
615	Thermal level at start	0...106	0...106%
616	Thermal level at end	0...106	0...106%
617	Temperature from RTD1	-40...999	-40...999°C ^{b)}
618	Temperature from RTD2	-40...999	-40...999°C ^{b)}
619	Temperature from RTD3	-40...999	-40...999°C ^{b)}
620	Temperature from RTD4	-40...999	-40...999°C ^{b)}
621	Temperature from RTD5	-40...999	-40...999°C ^{b)}
622	Temperature from RTD6	-40...999	-40...999°C ^{b)}
623	Thermistor 1, resistance value	0...200	0...20 kΩ ^{c)}
624	Thermistor 2, resistance value	0...200	0...20 kΩ ^{c)}
625	Pickup duration of element 49/38-1, alarm	0...100	0...100%
626	Pickup duration of element 49/38-1, trip	0...100	0...100%
627	Pickup duration of element 49/38-2, alarm	0...100	0...100%
628	Pickup duration of element 49/38-2, trip	0...100	0...100%
629	Pickup duration, element (48/14 PICKUP) ² x (48/14 TDLY) or 48/14	0...100	0...100%
630	Pickup duration, element 50P-1	0...100	0...100%
631	Pickup duration, element 46	0...100	0...100%
632	Pickup duration, element 51N	0...100	0...100%
633	Pickup duration, element 37	0...100	0...100%

^{a)} Readable and writeable register.

^{b)} If the input is out of operation or the optional RTD module has not been installed, the value -32768 will be returned.

^{c)} If the input is out of operation or the optional RTD module has not been installed, the value 655 will be returned.

Structure 3

This structure contains Modbus event records. Refer to Event records earlier in this section for the reading method.

Table 5.1.14.1.-15 Event record

Address	Signal name	Range	Comment
671	Latest selection code ^{a)}	1...3 -1...-99	1 = read oldest unread record 2 = read oldest stored record 3 = clear Modbus event buffer -1...-99 = move to the nth newest record
672	Sequence number	1...999	
673	Unread records left	0...99	
674	Time stamp of the event, date		2 bytes: YY.MM
675	Time stamp of the event, date and time		2 bytes: DD.HH
676	Time stamp of the event, time		2 bytes: MM.SS
677	Time stamp of the event, time	0...999	0...999 ms
678	Event data		See Table 5.1.14.1.-16 for Modbus DI-point events and Table 5.1.14.1.-17 for informative events
679			

^{a)} Readable and writable register.

Table 5.1.14.1.-16 Modbus DI-point event

Address	Name	Range	Comment
678	0 Modbus DI-point	1...99	MSB = 0
679	Modbus DI value	0...1	

Table 5.1.14.1.-17 Informative event

Address	Name	Range	Comment
678	1 SPA channel	0...3	MSB = 1
679	SPA event	0...63	

Structure 4

The relay's real-time clock is stored in this structure. It can be updated by presetting the whole register structure in one Modbus transaction.

Table 5.1.14.1.-18 Real-time clock structure

Address	Description	Range
721	Year	0...99
722	Month	1...12
723	Day	1...31
724	Hour	0...23
725	Minute	0...59
726	Second	0...59
727	Hundredth of a second	0...99

5.1.15.

SPA bus communication protocol parameters

Altering parameter values via serial communication requires the use of the SPA password in some cases. The password is a user-defined number within the range 1...999, the default value being 001. SPA parameters are found on channels 0...5, 504 and 507.

To enter the setting mode, enter the password into parameter V160. To exit the setting mode, enter the same password into parameter V161. The password protection is also reactivated in case of loss of auxiliary voltage.

The password can be changed with parameter V162, but it is not possible to read the password via this parameter. Abbreviations used in the following tables:

- R = readable data
- W = writeable data
- P = password protected writeable data

Settings**Table 5.1.15.-1 Settings**

Variable	Actual settings (R), channel 0	Group/ Channel 1 (R, W, P)	Group/ Channel 2 (R, W, P)	Setting range
Safe stall time	S1	1S1	2S1	2...120 s ^{a)}
Weighting factor	S2	1S2	2S2	20...100%
Time constant multiplier	S3	1S3	2S3	1...64
Prior alarm level	S4	1S4	2S4	50...100%
Restart disable level	S5	1S5	2S5	20...80%
Ambient temperature	S6	1S6	2S6	0...70°C
Start-up current for motor or pickup value of element 48/14	S7	1S7	2S7	1.00...10.0 x FLA
Start-up time for motor or operate time of element 48/14	S8	1S8	2S8	0.30...80.0 s
pickup value of element 50P-1	S9 ^{b)}	1S9	2S9	0.50...20.0 x FLA
Operate time of element 50P-1	S10	1S10	2S10	0.05...30.0 s
Pickup value of element 51N	S11 ^{b)}	1S11	2S11	1.0...100% I _n CT
Operate time of element 51N	S12	1S12	2S12	0.05...300 s
Pickup value of element 37	S13 ^{b)}	1S13	2S13	30...80% FLA
Operate time of element 37	S14	1S14	2S14	2...600 s

Technical Reference Manual - ANSI Version

Variable	Actual settings (R), channel 0	Group/ Channel 1 (R, W, P)	Group/ Channel 2 (R, W, P)	Setting range
Pickup value of element 46	S15 ^{b)}	1S15	2S15	0.10...0.50 x FLA
Time constant of element 46	S16	1S16	2S16	5...100
Restart disable value	S17	1S17	2S17	5...500 s
Countdown rate of start-up time counter	S18	1S18	2S18	2...250 s/h
Operate time of CBFAIL	S19	1S19	2S19	0.10...60.0 s
Alarm value RTD1A	S20 ^{b)}	1S20	2S20	0...200°C
Operate time RTD1A TDLY	S26	1S26	2S26	1...100 s
Trip value RTD1T	S32 ^{b)}	1S32	2S32	0...200°C
Operate time RTD1T TDLY	S38	1S38	2S38	1...100 s
Alarm value RTD2A	S21 ^{b)}	1S21	2S21	0...200°C
Operate time RTD2A TDLY	S27	1S27	2S27	1...100 s
Trip value RTD2T	S33 ^{b)}	1S33	2S33	0...200°C
Operate time RTD2T TDLY	S39	1S39	2S39	1...100 s
Alarm value RTD3A	S22 ^{b)}	1S22	2S22	0...200°C
Operate time RTD3A TDLY	S28	1S28	2S28	1...100 s
Trip value RTD3T	S34 ^{b)}	1S34	2S34	0...200°C
Operate time RTD3T TDLY	S40	1S40	2S40	1...100 s
Alarm value RTD4A	S23 ^{b)}	1S23	2S23	0...200°C
Operate time RTD4A TDLY	S29	1S29	2S29	1...100 s
Trip value RTD4T	S35 ^{b)}	1S35	2S35	0...200°C
Operate time RTD4T TDLY	S41	1S41	2S41	1...100 s
Alarm value RTD5A	S24 ^{b)}	1S24	2S24	0...200°C
Operate time RTD5A TDLY	S30	1S30	2S30	1...100 s
Trip value RTD5T	S36 ^{b)}	1S36	2S36	0...200°C
Operate time RTD5T TDLY	S42	1S42	2S21	1...100 s
Alarm value RTD6A	S25 ^{b)}	1S25	2S25	0...200°C
Operate time RTD6A TDLY	S31	1S31	2S31	1...100 s
Trip value RTD6T	S37 ^{b)}	1S37	2S37	0...200°C
Operate time RTD6T TDLY	S43	1S43	2S43	1...100 s
Trip value PTC1	S44 ^{b)}	1S44	2S44	0.1...15.0 kΩ
Trip value PTC2	S45 ^{b)}	1S45	2S45	0.1...15.0 kΩ

Variable	Actual settings (R), channel 0	Group/ Channel 1 (R, W, P)	Group/ Channel 2 (R, W, P)	Setting range
Checksum, SGF 1	S61	1S61	2S61	0...255
Checksum, SGF 2	S62	1S62	2S62	0...255
Checksum, SGF 3	S63	1S63	2S63	0...255
Checksum, SGF 4	S64	1S64	2S64	0...7
Checksum, SGF 5	S65	1S65	2S65	0...255
Checksum, SGB 1	S71	1S71	2S71	0...16383
Checksum, SGB 2	S72	1S72	2S72	0...16383
Checksum, SGB 3	S73 ^{c)}	1S73	2S73	0...16383
Checksum, SGB 4	S74 ^{c)}	1S74	2S74	0...16383
Checksum, SGB 5	S75 ^{c)}	1S75	2S75	0...16383
Checksum, SGR 1	S81	1S81	2S81	0...524287
Checksum, SGR 2	S82	1S82	2S82	0...524287
Checksum, SGR 3	S83	1S83	2S83	0...524287
Checksum, SGR 4	S84	1S84	2S84	0...524287
Checksum, SGR 5	S85	1S85	2S85	0...524287
Checksum, SGL 1	S91	1S91	2S91	0...4194303
Checksum, SGL 2	S92	1S92	2S92	0...4194303
Checksum, SGL 3	S93	1S93	2S93	0...4194303
Checksum, SGL 4	S94	1S94	2S94	0...4194303
Checksum, SGL 5	S95	1S95	2S95	0...4194303
Checksum, SGL 6	S96	1S96	2S96	0...4194303
Checksum, SGL 7	S97	1S97	2S97	0...4194303
Checksum, SGL 8	S98	1S98	2S98	0...4194303

^{a)} The setting step is 0.5.

^{b)} If the protection element is out of operation, the number indicating the currently used value will be displaced by "999" when parameters are read via the SPA bus and by dashes on the LCD.

^{c)} If the optional RTD module has not been installed, dashes will be shown on the LCD and "99999" when the parameter is read via the SPA bus.

Recorded data

Parameter V1 shows the element and phase which caused the trip. Parameter V2 shows the trip target code.

Parameter V3 the start-up time of the latest motor start up and parameters V4...V8 show the number of pickups of the protection elements.

Table 5.1.15.-2 Recorded data: Channel 0

Recorded data	Parameter (R)	Value
Element/phase which caused the trip	V1	1= $(48/14 \text{ PICKUP})^2 \times (48/14 \text{ TDLY})$ or 48/14 I _c 2= $(48/14 \text{ PICKUP})^2 \times (48/14 \text{ TDLY})$ or 48/14 I _b

Recorded data	Parameter (R)	Value
		$4=(48/14 \text{ PICKUP})^2 \times (48/14 \text{ TDLY}) \text{ or } 48/14 I_a$ 8=51N 16= I_c (50P) 32= I_b (50P) 64= I_a (50P) 128=46 256= I_c (37) 512= I_b (37) 1024= I_a (37) 2048=46R 4096=49 8192=49/38-1 16384=49/38-2 32768=external trip
Trip target code	V2	0 = — 1 = alarm of element 49 2 = trip of element 49 3 = pickup of element $(48/14 \text{ PICKUP})^2 \times (48/14 \text{ TDLY}) \text{ or } 48/14$ 4 = trip of element $(48/14 \text{ PICKUP})^2 \times (48/14 \text{ TDLY}) \text{ or } 48/14$ 5 = pickup of element 50P 6 = trip of element 50P 7 = pickup of element 37 8 = trip of element 37 9 = pickup of element 51N 10 = trip of element 51N 11 = pickup of element 46 12 = trip of element 46 13 = trip of element 46R 14 = external trip 15 = alarm of element 49/38-1 16 = trip of element 49/38-1 17 = alarm of element 49/38-2 18 = trip of element 49/38-2 19 = restart disable (49) 20 = restart disable (66) 21 = restart disable (external)
		22 = CBFAIL
Start-up time of the latest motor start up	V3	0..240 s

Recorded data	Parameter (R)	Value
Number of pickups of element (48/14 PICKUP)2 x (48/14 TDLY) or 48/14	V4	0...999
Number of pickups of element 50P	V5	0...999
Number of pickups of element 51N	V6	0...999
Number of pickups of element 37	V7	0...999
Number of pickups of element 46	V8	0...999

The last five recorded values can be read with parameters V1...V28 on channels 1...5. Event n denotes the last recorded value, n-1 the next one, and so forth.

Table 5.1.15.-3 Recorded data: Channels 1...5

Recorded data	Event (R)					Value
	n Channel 1	n-1 Channel 2	n-2 Channel 3	n-3 Channel 4	n-4 Channel 5	
Phase current I _a	1V1	2V1	3V1	4V1	5V1	0...50 x FLA
Phase current I _b	1V2	2V2	3V2	4V2	5V2	0...50 x FLA
Phase current I _c	1V3	2V3	3V3	4V3	5V3	0...50 x FLA
Ground-fault current	1V4	2V4	3V4	4V4	5V4	0...800% I _n CT
NPS current	1V5	2V5	3V5	4V5	5V5	0...50 x FLA
Thermal stress value	1V6	2V6	3V6	4V6	5V6	0...100%
Number of motor start ups	1V7	2V7	3V7	4V7	5V7	0...999
Thermal level at start	1V8	2V8	3V8	4V8	5V8	0...106%
Thermal level at end	1V9	2V9	3V9	4V9	5V9	0...106%
Temperature from RTD1	1V10	2V10	3V10	4V10	5V10	-40...+999°C
Temperature from RTD2	1V11	2V11	3V11	4V11	5V11	-40...+999°C
Temperature from RTD3	1V12	2V12	3V12	4V12	5V12	-40...+999°C
Temperature from RTD4	1V13	2V13	3V13	4V13	5V13	-40...+999°C
Temperature from RTD5	1V14	2V14	3V14	4V14	5V14	-40...+999°C
Temperature from RTD6	1V15	2V15	3V15	4V15	5V15	-40...+999°C
Thermistor1, resistance value	1V16	2V16	3V16	4V16	5V16	0...20 kΩ
Thermistor2, resistance value	1V17	2V17	3V17	4V17	5V17	0...20 kΩ
Pickup duration of element 49/38-1, alarm	1V18	2V18	3V18	4V18	5V18	0...100%

Recorded data	Event (R)					Value
	n Channel 1	n-1 Channel 2	n-2 Channel 3	n-3 Channel 4	n-4 Channel 5	
Pickup duration of element 49/38-1, trip	1V19	2V19	3V19	4V19	5V19	0...100%
Pickup duration of element 49/38-2, alarm	1V20	2V20	3V20	4V20	5V20	0...100%
Pickup duration of element 49/38-2, trip	1V21	2V21	3V21	4V21	5V21	0...100%
Pickup duration, element (48/14 PICKUP) ² x (48/14 TDLY) or 48/14	1V22	2V22	3V22	4V22	5V22	0...100%
Pickup duration, element 50P	1V23	2V23	3V23	4V23	5V23	0...100%
Pickup duration, element 46	1V24	2V24	3V24	4V24	5V24	0...100%
Pickup duration, element 51N	1V25	2V25	3V25	4V25	5V25	0...100%
Pickup duration, element 37	1V26	2V26	3V26	4V26	5V26	0...100%
Time stamp of the recorded data, date	1V27	2V27	3V27	4V27	5V27	YY-MM-DD
Time stamp of the recorded data, time	1V28	2V28	3V28	4V28	5V28	HH.MM; SS.sss

Disturbance recorder

Table 5.1.15.-4 Parameters for the disturbance recorder

Description	Parameter (channel 0)	R, W	Value
Remote triggering	M1 ^{a)}	W	1
Clear recorder memory	M2	W	1
Sampling rate	M15 ^{b)}	R, W	800/960 Hz 400/480 Hz 50/60 Hz
Station identification/unit number	M18	R, W	0...9999
Rated frequency	M19	R	50 or 60 Hz
Name of the motor drive	M20	R, W	Max 16 characters
Digital channel texts	M40...M47	R	-
Analog channel texts	M60...M63	R	-
Analog channel conversion factor and unit for I _a , I _b and I _c	M80 ^{c)d)}	R, W	Factor 0...65535, unit (A, kA), e.g. 10,kA
	M81 and	R	
	M82	R	

Description	Parameter (channel 0)	R, W	Value
Analog channel conversion factor and unit for the ground-fault current	M83 ^{c)}	R, W	Factor 0...65535, unit (A, kA), e.g. 10,kA
Internal trigger signals' checksum	V236	R, W	0...8191
Internal trigger signal's edge	V237	R, W	0...8191
Checksum of internal signal storing mask	V238 ^{b)}	R, W	0...8191
Post-triggering recording length	V240	R, W	0...100%
External trigger signal's checksum	V241	R, W	0...31
External trigger signal's edge	V242	R, W	0...31
Checksum of external signal storing mask	V243 ^{b)}	R, W	0...31
Triggering state, clearing and restart	V246	R, W	R: 0 = Recorder not triggered 1 = Recorder triggered and recording stored in the memory W: 0 = Clear recorder memory 2 = Download restart; sets the first information and the time stamp for triggering ready to be read 4 = Manual triggering

a) M1 can be used for broadcast triggering by using the unit address "900".

b) Parameters can be written if the recorder has not been triggered.

c) The disturbance recorder requires this parameter to be set. The conversion factor is the transformation ratio multiplied by the rated of the relay. If value 0 is given to this parameter, dashes are shown on the LCD instead of the primary values and the recorded data will be redundant.

d) This value is copied to parameters M81 and M82.

Table 5.1.15.-5 Disturbance recorder internal triggering and storing

Event	Weighting factor	Default value of triggering mask, V236	Default value of triggering edge, V237 ^{a)}	Default value of storing mask, V238
Alarm of element 49	1	0	0	0
Trip of element 49	2	0	0	1
Pickup of element (48/14 PICKUP) ² x (48/14 TDLY) or 48/14	4	0	0	0
Trip of element (48/14 PICKUP) ² x (48/14 TDLY) or 48/14	8	1	0	1
Pickup of element 50P-1	16	0	0	1
Trip of element 50P-1	32	1	0	1
Pickup of element 37	64	0	0	0

Event	Weighting factor	Default value of triggering mask, V236	Default value of triggering edge, V237	Default value of storing mask, V238
Trip of element 37	128	1	0	1
Pickup of element 51N	256	0	0	0
Trip of element 51N	512	1	0	1
Pickup of element 46	1024	0	0	0
Trip of element 46	2048	1	0	1
Motor start up	4096	0	0	1
Σ		2728	0	6842

a) 0 = rising edge, 1 = falling edge.

Table 5.1.15.-6 Disturbance recorder external triggering and storing

Event	Weighting factor	Default value of triggering mask, V241	Default value of triggering edge, V242 ^{a)}	Default value of storing mask, V243
DI1	1	0	0	0
DI2	2	0	0	0
DI3	4	0	0	0
DI4	8	0	0	0
DI5	16	0	0	0
Σ		0	0	0

a) 0 = rising edge; 1 = falling edge.

Table 5.1.15.-7 Control parameters

Description	Parameter	R, W, P	Value
Reading of the event buffer	L	R	Time, channel number and event code
Re-reading of the event buffer	B	R	Time, channel number and event code
Reading of relay state data	C	R	0 = Normal state 1 = The relay has been subject to an automatic reset 2 = Overflow of the event buffer 3 = Both 1 and 2
Resetting of relay state data	C	W	0 = Reset E50 and E51 1 = Reset only E50 2 = Reset only E51 4 = Reset all events including E51 except for E50
Time reading and setting	T	R, W	SS.sss
Date and time reading and setting	D	R, W	YY-MM-DD HH.MM;SS.sss
Type designation of the relay	F	R	REM610
Unlatching output contacts	V101	W	1 = Unlatch
Clearing targets and memorized values and unlatching contacts (master reset)	V102	W	1 = Clear and unlatch
FLA secondary (protected unit scaling factor)	V103	R, W (P)	0.50...2.50

Technical Reference Manual - ANSI Version

Description	Parameter	R, W, P	Value
Rated frequency	V104	R, W (P)	50 or 60 Hz
Time setting range for demand values in minutes	V105	R, W	0...999 min
Non-volatile memory settings	V106	R, W	0...63
Time setting for disabling new trip targets on the LCD	V108	R, W (P)	0...999 min
Activating the self-supervision	V109	W (P)	1 = Self-supervision output contact is activated and the READY target LED starts to flash 0 = Normal operation
LED test for pickup and trip targets	V110	W (P)	0 = Pickup and trip LEDs off 1 = Trip LED on, pickup LED off 2 = Pickup LED on, trip LED off 3 = and trip LEDs on
LED test for programmable LEDs	V111	W (P)	0...255
Trip-circuit supervision	V113	R, W	0 = Not in use 1 = In use
Store counter ^{a)}	V114	R	0...65535
Sensor/thermistor selection for input RTD1	V121 ^{b)}	R, W (P)	0 = not in use 1 = Pt100 -45...+150°C 2 = Pt250 -45...+150°C 3 = Pt1000 -45...+150°C 4 = Ni100 -45...+250°C 5 = Ni120 -45...+250°C 6 = Cu10 -45...+150°C 7 = Ni120US -45...+250°C 8 = PTC 0...20 kΩ
Sensor selection for input RTD2	V122 ^{b)}	R, W (P)	0 = not in use 1 = Pt100 -45...+150°C 2 = Pt250 -45...+150°C 3 = Pt1000 -45...+150°C 4 = Ni100 -45...+250°C 5 = Ni120 -45...+250°C 6 = Cu10 -45...+150°C 7 = Ni120US -45...+250°C
Sensor selection for input RTD3	V123 ^{b)}	R, W (P)	0 = not in use 1 = Pt100 -45...+150°C 2 = Pt250 -45...+150°C 3 = Pt1000 -45...+150°C 4 = Ni100 -45...+250°C 5 = Ni120 -45...+250°C 6 = Cu10 -45...+150°C 7 = Ni120US -45...+250°C
Sensor/thermistor selection for input RTD4	V124 ^{b)}	R, W (P)	0 = not in use 1 = Pt100 -45...+150°C 2 = Pt250 -45...+150°C 3 = Pt1000 -45...+150°C 4 = Ni100 -45...+250°C 5 = Ni120 -45...+250°C 6 = Cu10 -45...+150°C 7 = Ni120US -45...+250°C 8 = PTC 0...20 kΩ

Technical Reference Manual - ANSI Version

Description	Parameter	R, W, P	Value
Sensor selection for input RTD5	V125 ^{b)}	R, W (P)	0 = not in use 1 = Pt100 -45...+150°C 2 = Pt250 -45...+150°C 3 = Pt1000 -45...+150°C 4 = Ni100 -45...+250°C 5 = Ni120 -45...+250°C 6 = Cu10 -45...+150°C 7 = Ni120US -45...+250°C
Sensor selection for input RTD6	V126 ^{b)}	R, W (P)	0 = not in use 1 = Pt100 -45...+150°C 2 = Pt250 -45...+150°C 3 = Pt1000 -45...+150°C 4 = Ni100 -45...+250°C 5 = Ni120 -45...+250°C 6 = Cu10 -45...+150°C 7 = Ni120US -45...+250°C
Remote control of setting group	V150	R, W	0 = Setting group 1 1 = Setting group 2
Entering the SPA password for settings	V160	W	1...999
Changing the SPA password or taking the password protection into use	V161	W (P)	1...999
Changing the HMI Setting password	V162	W	1...999
Changing the HMI Communication password	V163	W	1...999
Clearing trip counters or AR counter	V166	W (P)	1 = Clear trip counters 2 = Clear AR counters
Restoring factory settings	V167	W (P)	2 = Restore factory settings for CPU 3 = Restore factory settings for RTD 4 = Restore factory settings for CPU and RTD
Warning code	V168	R	0...63 ^{c)}
IRF code	V169	R	0...255 ^{c)}
Unit address of the relay	V200	R, W	1...254
Data transfer rate (SPA), kbps	V201	R, W	9.6/4.8
Rear communication	V202	W	1 = Rear connector activated
Rear communication protocol	V203	R, W	0 = SPA 1 = IEC_103 2 = Modbus RTU 3 = Modbus ASCII
Connection type	V204	R, W	0 = Loop 1 = Star
Line-idle state	V205	R, W	0 = Light off 1 = Light on
Optional communication module	V206	R, W (P)	0 = Not in use 1 = In use ^{d)}
HMI language set information	V226	R	00...99
CPU software number	V227	R	1MRS118511
CPU software revision	V228	R	A...Z
CPU build number	V229	R	XXX
RTD software number	1V227	R	1MRS118514
RTD software revision	1V228	R	A...Z

Description	Parameter	R, W, P	Value
RTD build number	V229	R	XXX
Relay serial number	V230	R	BAxxxxxx
CPU serial number	V231	R	ACxxxxxx
RTD serial number	V232	R	ARxxxxxx
Test date	V235	R	YYMMDD
Date reading and setting (RED500 format)	V250	R, W	YY-MM-DD
Time reading and setting (RED500 format)	V251	R, W	HH.MM;SS.sss

a) The store counter can be used for monitoring parameter changes, for instance. The store counter is incremented by one on each parameter change via the HMI or serial communication. When the counter reaches its maximum value, it will roll over. If the factory settings are restored, the counter is cleared.

b) The supply voltage should not be disconnected less than ten seconds after writing to parameters V121...V126.

c) In case of a warning, the value 255 is stored in V169. This enables the master to continuously read only V169.

d) If the optional communication module is not installed, a warning of a faulty communication module appears on the LCD together with the fault code.

The measured currents can be read with parameters I1...I4, the calculated NPS current value with parameter I5, the status of the digital inputs with parameters I6...I10, the temperatures from RTD1...RTD6 with parameters I11...I16 and the resistance values of thermistors 1 and 2 with parameters I17 and I18.

Table 5.1.15.-8 Input signals

Description	Channel	Parameter (R)	Value
Current measured on phase I _a	0	I1	0...50 x FLA
Current measured on phase I _b	0	I2	0...50 x FLA
Current measured on phase I _c	0	I3	0...50 x FLA
Measured ground-fault current	0	I4	0...800% I _n (CT)
Calculated NPS current	0	I5	0...50 x FLA
DI1 status	0,2	I6	0/1 ^{a)}
DI2 status	0,2	I7	0/1 ^{a)}
DI3 status	0,2	I8	0/1 ^{a)} b)
DI4 status	0,2	I9	0/1 ^{a)} b)
DI5 status	0,2	I10	0/1 ^{a)} b)
Temperature from RTD1	0	I11	-40...+999 ^{c)}
Temperature from RTD2	0	I12	-40...+999 ^{c)}
Temperature from RTD3	0	I13	-40...+999 ^{c)}
Temperature from RTD4	0	I14	-40...+999 ^{c)}
Temperature from RTD5	0	I15	-40...+999 ^{c)}
Temperature from RTD6	0	I16	-40...+999 ^{c)}
Thermistor1, resistance value	0	I17	0...20 kΩ ^{d)}
Thermistor2, resistance value	0	I18	0...20 kΩ ^{d)}

a) When the value is 1, the digital input is energized.

b) If the optional RTD module has not been installed, a dash will be shown on the LCD and "9" when parameters are read via the SPA bus.

c) If the input is out of operation or the optional RTD module has not been installed or is faulty, dashes will be shown on the LCD and "-999" when parameters are read via the SPA bus.

Table footnotes from previous page

d) If the input is out of operation or the optional RTD module has not been installed or is faulty, dashes will be shown on the LCD and "999" when parameters are read via the SPA bus.

Each protection element has its internal output signal. These signals can be read with parameters O1...O21 and the recorded functions with parameters O61...O81. The state of the output contacts can be read or changed with parameters O41...O46 and the recorded functions read with parameters O101...O105.

Table 5.1.15.-9 Output signals

Status of the protection elements	Channel	State of element (R)	Recorded functions (R)	Value
Pickup of element 49	0,1	O1	O61	0/1
Alarm of element 49	0,1	O2	O62	0/1
Trip of element 49	0,1	O3	O63	0/1
Pickup of element (48/14 PICKUP) ² x (48/14 TDLY) or 48/14	0,1	O4	O64	0/1
Trip of element (48/14 PICKUP) ² x (48/14 TDLY) or 48/14	0,1	O5	O65	0/1
Pickup of element 50P-1	0,1	O6	O66	0/1 ;
Trip of element 51N	0,1	O7	O67	0/1
Pickup of element 37	0,1	O8	O68	0/1
Trip of element 37	0,1	O9	O69	0/1
Pickup of element 51N	0,1	O10	O70	0/1
Trip of element 51N	0,1	O11	O71	0/1
Pickup of element 46	0,1	O12	O72	0/1
Trip of element 46	0,1	O13	O73	0/1
Trip of element 46R	0,1	O14	O74	0/1
External trip	0,1	O15	O75	0/1
Motor start up	0,1	O16	O76	0/1
Restart disable	0,1	O17	O77	0/1
Alarm of element 49/38-1	0,2	O18	O78	0/1

Status of the protection elements	Channel	State of element (R)	Recorded functions (R)	Value
Trip of element 49/38-1	0,2	O19	O79	0/1
Alarm of element 49/38-2	0,2	O20	O80	0/1
Trip of element 49/38-2	0,2	O21	O81	0/1
CBFAIL trip	0,3	O22	O82	0/1

Table 5.1.15.-10 Outputs

Operation of output contact	Channel	State of output (R, W, P)	Recorded functions (R)	Value
Output PO1	0,2	O41	O101	0/1
Output PO2	0,2	O42	O102	0/1
Output PO3 ^{a)}	0,2	O43	O103	0/1 ^{b)}
Output SO1	0,2	O44	O104	0/1
Output SO2	0,2	O45	O105	0/1
Output PO3 (restart disable) ^{c)}	0,2	O46	-	0/1 ^{b)}
Enabling activation of output contacts PO1, PO2, PO3, SO1, and SO2 via the SPA bus	0,2	O51	-	0/1

^{a)} State of output when the pickup, trip and alarm signals from the protection elements, the motor start-up signal and the external trip signal have been routed to PO3 (SGR3/1...19=1), provided that SGF1/7=1.

^{b)} Either O43/O103 or O46 is to be used at a time.

^{c)} State of output when the trip lockout function is in use.



Parameters O41...O46 and O51 control the physical output contacts which can be connected to circuit breakers, for instance.

Parameters for IEC 60870-5-103 remote communication protocol

Table 5.1.15.-11 Settings

Description	Parameter (channel 507)	R, W, P	Value
Unit address of the relay	507V200	R, W	1...254
Data transfer rate (IEC 60870-5-103), kbps	507V201	R, W (P)	9.6/4.8

Parameters for Modbus remote communication protocol

Table 5.1.15.-12 Settings

Description	Parameter (channel 504)	R, W, P	Value
User-defined register 1	504V1	R, W	0...65535 ^{a)}
User-defined register 2	504V2	R, W	0...65535 ^{a)}
User-defined register 3	504V3	R, W	0...65535 ^{a)}
User-defined register 4	504V4	R, W	0...65535 ^{a)}
User-defined register 5	504V5	R, W	0...65535 ^{a)}
User-defined register 6	504V6	R, W	0...65535 ^{a)}
User-defined register 7	504V7	R, W	0...65535 ^{a)}
User-defined register 8	504V8	R, W	0...65535 ^{a)}
User-defined register 9	504V9	R, W	0...65535 ^{a)}
User-defined register 10	504V10	R, W	0...65535 ^{a)}
User-defined register 11	504V11	R, W	0...65535 ^{a)}
User-defined register 12	504V12	R, W	0...65535 ^{a)}
User-defined register 13	504V13	R, W	0...65535 ^{a)}
User-defined register 14	504V14	R, W	0...65535 ^{a)}
User-defined register 15	504V15	R, W	0...65535 ^{a)}
User-defined register 16	504V16	R, W	0...65535 ^{a)}
Unit address of the relay	504V200	R, W	1...254
Data transfer rate (Modbus), kbps	504V201	R, W	9.6/4.8/2.4/1.2/0.3
Modbus link parity	504V220	R, W	0 = even 1 = odd 2 = no parity
CRC order of Modbus RTU link	504V221	R, W	0 = low/high 1 = high/low

^{a)} The default value is 0.

Measurements

Table 5.1.15.-13 Measured values

Description	Parameter (channel 0)	R, W, P	Value
Cumulative start-up counter	V51	R	0...999 s
Time to next possible motor start up	V52	R	0...999 min
Motor running time	V53	R, W (P)	0...999 x 100 h ^{a)}
Maximum phase current during motor start up	V54	R	0...50 x FLA
Maximum phase current after motor start up	V56	R	0...50 x FLA
Maximum ground-fault current after motor start up	V57	R	0...800% I _n (CT)
Minimum phase current after motor start up	V58	R	0...50 x FLA ^{b)}
Minimum ground-fault current after motor start up	V59	R	0...800% I _n (CT) ^{b)}
Thermal level	V60	R, W (P)	0...106% ^{c)d)}
One-minute average current value	V61	R	0...50 x FLA ^{e)}
Average current value during the specified time range	V62	R	0...50 x FLA ^{e)}
Maximum one-minute average current value during the specified time range	V63	R	0...50 x FLA ^{e)}

^{a)} Writing to the parameter will reset the number of motor start ups.

^{b)} During motor start up, the value will be displaced by dashes on the LCD and by "999" when parameters are read via the SPA bus.

^{c)} Changing the thermal level via serial communication will generate an event code.

^{d)} If the thermal protection has been set out of operation, the parameter cannot be written to, and dashes will be shown on the LCD and "999" when the thermal level is read via the SPA bus.

^{e)} If the demand value is reset and the specified time has not elapsed, dashes are shown on the LCD and "999" when the parameter is read via the SPA bus.

5.1.15.1.

Event codes

Special codes are determined to represent certain events, such as pickup and tripping of protection elements and different states of output signals.

The events are stored in the event buffer of the relay. The maximum capacity of the buffer is 100 events. Under normal conditions the buffer is empty.

The contents of the buffer can be read using the **L** command, 5 events at a time. Using the **L** command erases the previously read events from the buffer, with the exception of events E50 and E51 which have to be reset by using the **C** command. If a fault occurs and reading fails for example in data communication, the events can be re-read by using the **B** command. If needed, the **B** command can also be repeated.

Events to be included in the event reporting are marked with the multiplier 1. The event mask is formed by the sum of the weighting factors of all those events which are to be included in event reporting.

Table 5.1.15.1-1 Event masks

Event mask	Code	Setting range	Default setting
V155	E31...E36	0...63	1
1V155	1E1...1E14	0...16383	4180
1V156	1E15...1E26	0...4095	1365
1V157	1E27...1E38	0...4095	341
2V155	2E1...2E10	0...1023	3
2V156	2E11...2E20	0...1023	0
2V157	2E21...2E28	0...255	0

Channel 0

Events always included in the event reporting:

Table 5.1.15.1-2 Event codes E1...E7

Channel	Event	Description
0	E1	IRF
0	E2	IRF disappeared
0	E3	Warning
0	E4	Warning disappeared
0	E5	Emergency start activated
0	E6	Emergency start deactivated
0	E7	The thermal level has been changed via serial communication

Table 5.1.15.1-3 Event codes E50...E51

Channel	Event	Description
0	E50	Relay restart
0	E51	Event buffer overflow

Events possible to mask out:

Table 5.1.15.1-4 Event codes E31...E36

Channel	Event	Description	Weighting factor	Default value
0	E31	Disturbance recorder triggered	1	1
0	E32	Disturbance recorder memory cleared	2	0
0	E33	HMI Setting password opened	4	0
0	E34	HMI Setting password closed	8	0
0	E35	HMI Communication password opened	16	0
0	E36	HMI Communication password closed	32	0
Default value of event mask V155				1

Channel 1

Table 5.1.15.1.-5 Event codes E1...E14

Channel	Event	Description	Weighting factor	Default value
1	E1	Motor start up begins	1	1
1	E2	Motor start up ends	2	0
1	E3 ^{a)}	Pickup of element 49 activated	4	1
1	E4 ^{a)}	Pickup of element 49 reset	8	0
1	E5	Alarm signal from element 49	16	1
1	E6	Alarm signal from element 49	32	0
1	E7	Trip signal from element 49 activated	64	1
1	E8	Trip signal from element 49 reset	128	0
1	E9	Restart disable signal from element 49	256	1
1	E10	Restart disable signal from element 49	512	0
1	E11	Restart disable signal from element 66	1024	1
1	E12	Restart disable signal from element 66	2048	0
1	E13 ^{b)}	Restart disable activated	4096	1
1	E1	Restart disable reset	8192	0
Default value of event mask 1V155				4180

^{a)} The event code is not generated during motor start up.

^{b)} The thermal restart disable level is exceeded, the start-up time counter is full or the external restart disable signal is active.

Table 5.1.15.1.-6 Event codes E15...E26

Channel	Event	Description	Weighting factor	Default value
1	E15 ^{a)}	Pickup signal from element (48/14 PICKUP) ² x (48/14 TDLY) or 48/14 activated	1	1
1	E16 ^{a)}	Pickup signal from element (48/14 PICKUP) ² x (48/14 TDLY) or 48/14 reset	2	0
1	E17	Trip signal from element (48/14 PICKUP) ² x (48/14 TDLY) or 48/14 activated	4	1
1	E18	Trip signal from element (48/14 PICKUP) ² x (48/14 TDLY) or 48/14 reset	8	0
1	E19 ^{a)}	Pickup signal from element 50P activated	16	1
1	E20 ^{a)}	Pickup signal from element 50P reset	32	0
1	E21	Trip signal from element 50P activated	64	1
1	E22	Trip signal from element 50P reset	128	0
1	E23 ^{a)}	Pickup signal from element 37 activated	256	1
1	E24 ^{a)}	Pickup signal from element 37 reset	512	0
1	E25	Trip signal from element 37 activated	1024	1
1	E26	Trip signal from element 37 reset	2048	0
Default value of event mask 1V156				1365

^{a)} The event code is not generated during motor start up.

Table 5.1.15.1-7 Event codes E27...E38

Channel	Event	Description	Weighting factor	Default value
1	E27 ^{a)}	Pickup signal from element 51N activated	1	1
1	E28 ^{a)}	Pickup signal from element 51N reset	2	0
1	E29	Trip signal from element 51N activated	4	1
1	E30	Trip signal from element 51N reset	8	0
1	E31 ^{a)}	Pickup signal from element 46 activated	16	1
1	E32 ^{a)}	Pickup signal from element 46 reset	32	0
1	E33	Trip signal from element 46 activated	64	1
1	E34	Trip signal from element 46 reset	128	0
1	E35	Trip signal from element 46R activated	256	1
1	E36	Trip signal from element 46R reset	512	0
1	E37	CBFAIL activated	1024	0
1	E38	CBFAIL reset	2048	0
Default value of event mask 1V157				341

^{a)} The event code is not generated during motor start up.

Channel 2

Table 5.1.15.1-8 Event codes E1...E10

Channel	Event	Description	Weighting factor	Default value
2	E1	PO1 activated	1	1
2	E2	PO1 reset	2	1
2	E3	PO2 activated	4	0
2	E4	PO2 reset	8	0
2	E5	PO3 activated	16	0
2	E6	PO3 reset	32	0
2	E7	SO1 activated	64	0
2	E8	SO1 reset	128	0
2	E9	SO2 activated	256	0
2	E10	SO2 reset	512	0
Default value of event mask 2V155				3

Table 5.1.15.1-9 Event codes E11...E20

Channel	Event	Description	Weighting factor	Default value
2	E11	DI1 activated	1	0
2	E12	DI1 deactivated	2	0
2	E13	DI2 activated	4	0
2	E14	DI2 deactivated	8	0
2	E15	DI3 activated	16	0
2	E16	DI3 deactivated	32	0
2	E17	DI4 activated	64	0
2	E18	DI4 deactivated	128	0

Channel	Event	Description	Weighting factor	Default value
2	E19	DI5 activated	256	0
2	E20	DI5 deactivated	512	0
Default value of event mask 2V156				0

Table 5.1.15.1.-10 Event codes E21...E28

Channel	Event	Description	Weighting factor	Default value
2	E21	Alarm signal from element 49/38-1 activated	1	0
2	E22	Alarm signal from element 49/38-1 reset	2	0
2	E23	Trip signal from element 49/38-1 activated	4	0
2	E24	Trip signal from element 49/38-1 reset	8	0
2	E25	Alarm signal from element 49/38-2 activated	16	0
2	E26	Alarm signal from element 49/38-2 reset	32	0
2	E27	Trip signal from element 49/38-2 activated	64	0
2	E28	Trip signal from element 49/38-2 reset	128	0
Default value of event mask 2V157				0

5.1.16.**Self-supervision (IRF) system**

The relay is provided with an extensive self-supervision system which continuously supervises the software and the electronics of the relay. It handles run-time fault situations and informs the user about an existing fault via a LED on the HMI and a text message on the LCD. There are two types of fault targets: IRF targets and warnings.

Internal relay fault

When an internal relay fault preventing relay operation is detected, the relay first tries to eliminate the fault by restarting. Only after the fault is found to be permanent, the green target LED (ready) begins to flash and the self-supervision output contact is activated. All other output contacts are returned to the initial state and locked for the internal relay fault. Further, a fault target message appears on the LCD, including a fault code.

IRF targets have the highest priority on the HMI. None of the other HMI targets can override the IRF target. As long as the green target LED (ready) is flashing, the fault target cannot be cleared. In case an internal fault disappears, the green target LED (ready) stops flashing and the relay is returned to the normal service state, but the fault target message remains on the LCD until manually cleared (or a motor start up begins).

The IRF code indicates the type of internal relay fault. When a fault appears, the code is to be recorded and stated when ordering service. The fault codes are listed in the following table:

Table 5.1.16.-1 IRF codes

Fault code	Type of fault
4	Error in output relay PO1
5	Error in output relay PO2
6	Error in output relay PO3
7	Error in output relay SO1
8	Error in output relay SO2
9	Error in the enable signal for output relay PO1, PO2, SO1 or SO2
10, 11, 12	Error in the feedback, enable signal or output relay PO1, PO2, SO1 or SO2
20, 21	Auxiliary voltage dip
30	Faulty program memory
50, 59	Faulty work memory
51, 52, 53 ^{a)} , 54, 56	Faulty parameter memory ^{b)}
55	Faulty parameter memory, calibration parameters
75	RTD module faulty
80	RTD module missing
81	RTD module unknown
82	RTD module configuration error
85	Power supply module faulty
86	Power supply module unknown
90	Hardware configuration error
95	Communication module unknown
104	Faulty configuration set (for IEC 60870-5-103)
131, 139, 195, 203, 222, 223	Internal reference voltage error
253	Error in the measuring unit

^{a)} Can be corrected by restoring factory settings for CPU.

^{b)} All settings will be zero during the fault.

For further information on internal relay faults, refer to the Operator’s Manual.

Warnings

In case of a warning, the relay continues to operate except for those protection functions possibly affected by the fault, and the green target LED (ready) remains lit as during normal operation. Further, a fault target message, which depending on the type of fault includes a fault code, appears on the LCD. If more than one type of fault occur at the same time, one single numeric code which indicates all the faults is displayed. The fault target message cannot be manually cleared but it disappears with the fault.

When a fault appears, the fault target message is to be recorded and stated when ordering service. The fault codes are listed in the following table:

Table 5.1.16.-2 Warning codes

Fault	Weight value
Battery low	1
Trip-circuit supervision ^{a)}	2
Power supply module temperature high	4
Communication module faulty or missing	8
RTD module faulty	16
Temperature sensor range error	32
Sensor circuit open or shorted (RTD1)	64
Sensor circuit open or shorted (RTD2)	128
Sensor circuit open or shorted (RTD3)	256
Sensor circuit open or shorted (RTD4)	512
Sensor circuit open or shorted (RTD5)	1024
Sensor circuit open or shorted (RTD6)	2048
Thermistor circuit open or shorted (Thermistor1)	4096
Thermistor circuit open or shorted (Thermistor2)	8192
Σ	16383

^{a)} The external fault warning can be routed to SO2 with SGF1/8.

For further information on warnings, refer to the Operator's Manual.

5.1.16.1.

Self-supervision of the RTD module

Each input sample is validated before it is fed into the filter algorithm. The samples are validated by measuring an internally set reference voltage immediately after the inputs have been sampled. If the measured offset voltage deviates from the set value by more than 1.5 per cent from the measuring range, the sample will be discarded. If the fault has not disappeared on expiration of the filter time of eight seconds, all inputs will automatically be set out of operation to indicate a hardware fault. Should the fault later disappear, the inputs will be re-enabled. This will prevent most sudden hardware faults from affecting the measured value.

To ensure that the specified measurement accuracy is achieved, a more thorough test of the hardware will be performed as part of the continuous self-calibration procedure to identify errors which degrade the measurement accuracy. If the self-calibration of the RTD module fails, all inputs will automatically be set out of operation to indicate a hardware fault. Should the self-calibration later succeed, the inputs will be re-enabled.

Additionally, a single input will be set out of operation if the measured value is outside the specified limits (-4%...104%) or if an open-loop or a short-circuit condition is detected.

5.1.17.

Relay parameterization

The parameters of the relay can be set either locally via the HMI or externally via serial communication with Relay Setting Tool.

Local parameterization

When the parameters are set locally, the setting parameters can be chosen via the hierarchical menu structure. The wanted language can be selected for parameter descriptions. Refer to the Operator's Manual for further information.

External parameterization

Relay Setting Tool is used for parameterizing the relay units. Adjusting the parameter values using Relay Setting Tool is done off-line, after which the parameters can be downloaded to the relay via a communication port.

5.2. Design description

5.2.1. Input/output connections

All external circuits are connected to the terminals on the rear panel of the relay.

- Terminals X2.1- are dimensioned for one 0.5...6.0 mm² (AWG 20-8) wire or two max 2.5 mm² (AWG 24-12) wires
- Terminals X3.1- and X4.1- are dimensioned for one 0.2...2.5 mm² wire or two 0.2...1.0 mm² (AWG 24-16) wires.

The energizing phase currents of the relay are connected to terminals:

- X2.1/1-2
- X2.1/3-4
- X2.1/5-6

For inputs for ground-fault currents, refer to Table 5.2.1.-1.



The relay can also be used in single or two-phase applications by leaving one or two energizing inputs unoccupied. However, at least terminals X2.1/1-2 must be connected.

The energizing of the relay is connected to terminals X2.1/7-8, see Table 5.2.1.-1.

The input terminals of the optional RTD module are located on connection socket X3.1. The RTD sensors or thermistors are connected to terminals X3.1/7-24, see Table 5.2.1.-6. Both the inner and the outer shield of the cable must be connected to the chassis ground screw between connectors X4.1 and X3.1 (lower screw). In addition, the outer shield must be connected to chassis ground at the other end of the cable as well.



When connection socket X3.1 is used, the RTD module must be installed.



Unused RTD inputs are to be short-circuited separately.

Terminals X4.1/21-24 and X3.1/1-6 (optional) are digital input terminals, see Table 5.2.1.-5. The digital inputs can be used to generate a blocking signal, to unlatch output contacts or for remote control of relay settings, for instance. The requested functions are selected separately for each input in switchgroups SGB1...5. The digital inputs can also be used to trigger the disturbance recorder; this function is selected with SPA parameter V243.

The auxiliary voltage of the relay is connected to terminals X4.1/1-2, see Table 5.2.1.-2. At DC supply, the positive lead is connected to terminal X4.1/1. The permitted auxiliary voltage range of the relay is marked on the front panel of the relay under the handle of the plug-in unit.

Output contacts PO1, PO2 and PO3 (restart disable) are heavy-duty trip contacts capable of controlling most circuit breakers, see Table 5.2.1.-4. The trip signals from the different protection elements are routed to the trip output with the switches of switchgroups SGR1...SGR3. On delivery from the factory, the trip signals from all the protection elements except 49/38-1 and 49/38-2 are routed to both PO1 and PO2 and the restart disable signal to PO3.

Output contacts SO1...SO5 can be used for signalling on pickup and tripping of the relay, see Table 5.2.1.-4. The signals to be routed to signal outputs SO1 and SO2 are selected with the switches of switchgroups SGR4 and SGR5. On delivery from the factory, the pickup and alarm signals from all the protection elements except 49/38-1 and 49/38-2 are routed to SO1 and SO2.

The IRF contact functions as an output contact for the self-supervision system of the protection relay, see Table 5.2.1.-3. Under normal operating conditions, the relay is energized and the contact is closed (X4.1/3-5). When a fault is detected by the self-supervision system or the auxiliary voltage is disconnected, the output contact drops off and the contact closes (X4.1/3-4).

Fig. 5.2.1.-1 and Fig. 5.2.1.-2 present a rear view of the relay, showing four connecting sockets: one for measuring transformers, one for the optional RTD module, one for power supply and one for optional serial communication.

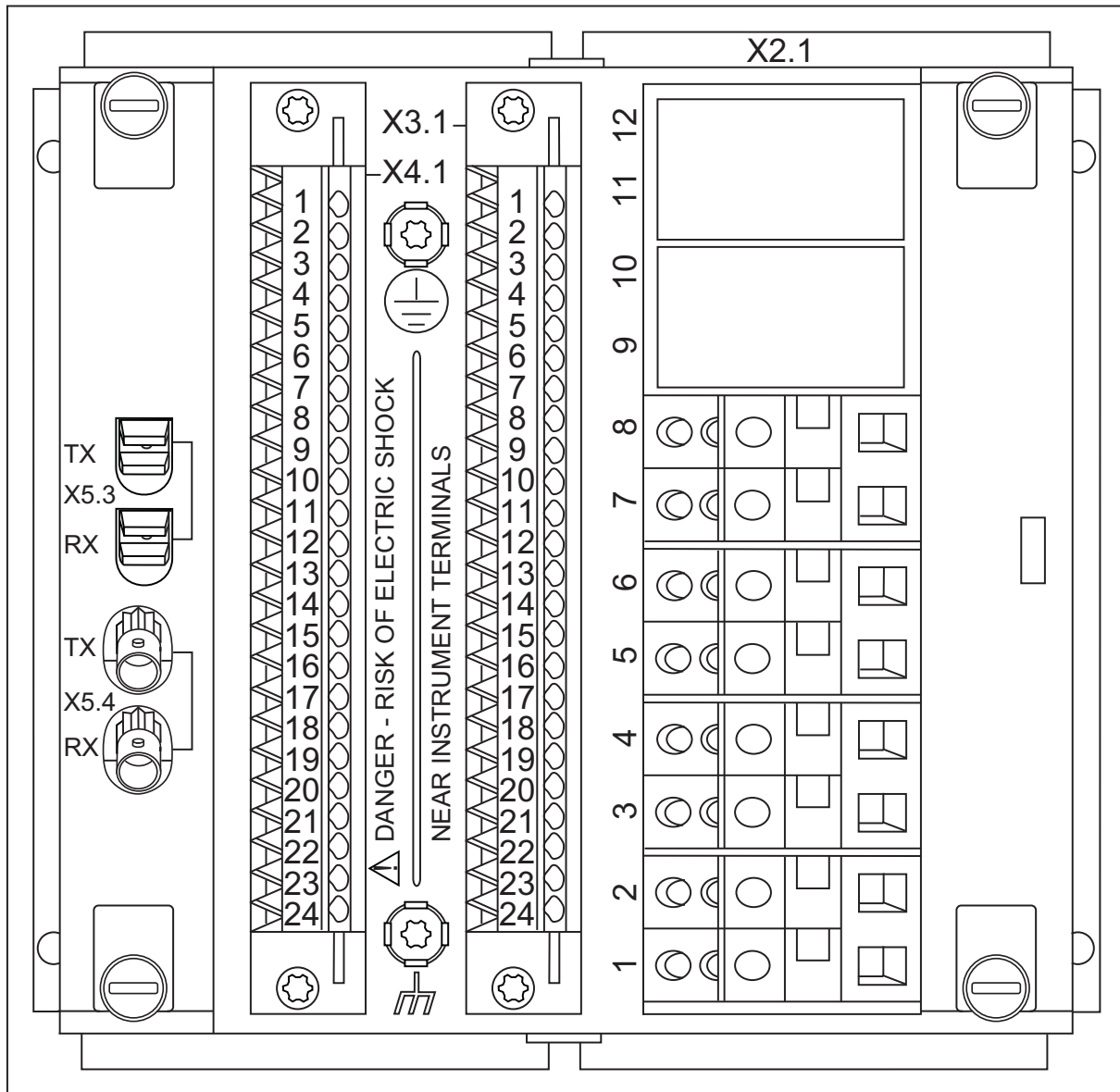

A051555

Fig. 5.2.1.-1 Rear view of the relay with the fibre-optic communication module for plastic and glass fibre

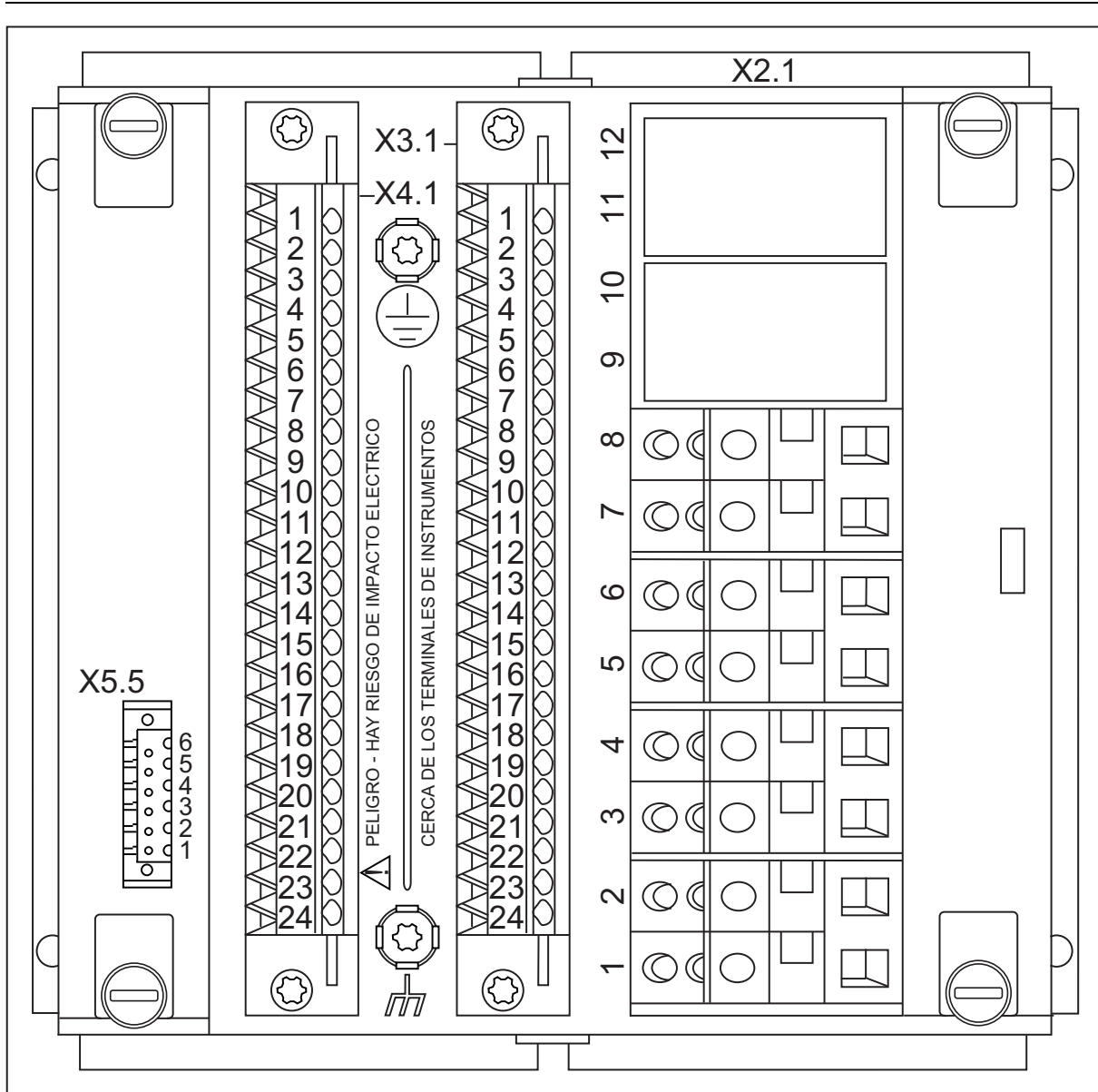

A051554

Fig. 5.2.1.-2 Rear view of the relay with the RS-485 communication module

Table 5.2.1.-1 Inputs for phase and ground-fault currents

Terminal	Function ^{a)}			
	REM610x11xxxx	REM610x15xxx-x	REM610x51xxxx	REM610x55xx-xx
X2.1-1	I _a 1 A	I _a 1 A	I _a 5 A	I _a 5 A
X2.1-2				
X2.1-3	I _b 1 A	I _b 1 A	I _b 5 A	I _b 5 A
X2.1-4				
X2.1-5	I _c 1 A	I _c 1 A	I _c 5 A	I _c 5 A
X2.1-6				
X2.1-7	I _n 1 A	I _n 5 A	I _n 1 A	I _n 5 A
X2.1-8				

Terminal	Function			
	REM610x11xxx	REM610x15xxx- x	REM610x51xxxx	REM610x55xx- xx
X2.1-9	-	-	-	-
X2.1-10	-	-	-	-
X2.1-11	-	-	-	-
X2.1-12	-	-	-	-

^{a)} The value denotes the rated current for each input.

Table 5.2.1.-2 Auxiliary supply voltage

Terminal	Function
X4.1-1	Input, +
X4.1-2	Input, -

Table 5.2.1.-3 IRF contact

Terminal	Function
X4.1-3	IRF, common
X4.1-4	Closed; IRF, or U_{aux} disconnected
X4.1-5	Closed; no IRF, and U_{aux} connected

Table 5.2.1.-4 Output contacts

Terminal	Function
X4.1-6	SO2, common
X4.1-7	SO2, NC
X4.1-8	SO2, NO
X4.1-9	SO1, common ^{a)}
X4.1-10	SO1, NC ^{a)}
X4.1-11	SO1, NO ^{a)}
X4.1-12	PO3 (restart disable), NC ^{b)}
X4.1-13	
X4.1-14	PO2, NO
X4.1-15	
X4.1-16	PO1, NO
X4.1-17	
X4.1-18	PO1 (TCS), NO
X4.1-19	
X4.1-20	-

^{a)} This output is intended to be used with contactor controlled motors.

^{b)} If the restart disable signal has not been routed to PO3 (SGF1/7=1), PO3 will be NO.

Table 5.2.1.-5 Digital inputs

Terminal	Function
X4.1-23 X4.1-24	DI1
X4.1-21 X4.1-22	DI2
X3.1-1 X3.1-2	DI3 ^{a)}
X3.1-3 X3.1-4	DI4 ^{a)}
X3.1-5 X3.1-6	DI5 ^{a)}

^{a)} Optional.

Table 5.2.1.-6 RTD inputs (optional)

Terminal	Function
X3.1-7 X3.1-8 X3.1-9	RTD1, + RTD1, - RTD1, common
X3.1-10 X3.1-11 X3.1-12	RTD2, + RTD2, - RTD2, common
X3.1-13 X3.1-14 X3.1-15	RTD3, + RTD3, - RTD3, common
X3.1-16 X3.1-17 X3.1-18	RTD4, + RTD4, - RTD4, common
X3.1-19 X3.1-20 X3.1-21	RTD5, + RTD5, - RTD5, common
X3.1-22 X3.1-23 X3.1-24	RTD6, + RTD6, - RTD6, common

5.2.2.

Serial communication connections

The optical front connection of the relay is used to connect the relay to the SPA bus via the front communication cable, refer to Section 7. Ordering information. If a PC compatible to the IrDA® Standard specifications is used, wireless communication is possible as well. The maximum wireless operating distance depends on the transceiver of the PC.

Rear communication of the relay is optional and the physical connection varies with the communication option.

Plastic fibre-optic connection

If the relay is provided with the optional fibre-optic communication module for plastic fibre, the fibre-optic cables are connected to terminals as follows:

Table 5.2.2.-1 Plastic fibre-optic rear connection

Terminal	Function
X5.3-TX	Transmitter
X5.3-RX	Receiver

RS-485 connection

If the relay is provided with the optional RS-485 communication module, the cable is connected to terminals X5.5/1-2 and X5.5/4-6. The connection socket is a 6-pin header-type socket and the terminals are of screw compression type.

The RS-485 communication module follows the TIA/EIA-485 standard and is intended to be used in a daisy-chain bus wiring scheme with 2-wire, half-duplex, multi-point communication.



The maximum number of devices (nodes) connected to the bus where the relay is being used is 32, and the maximum length of the bus is 1200 meters.

When connecting the relay to the bus, a quality twisted pair shielded cable is to be used. The conductors of the pair are connected to A and B. If signal ground is being used for balancing potential differences between devices/nodes, a quality dual twisted pair shielded cable is to be used. In this case, one pair is connected to A and B, and one of the conductors of the other pair to signal ground. When connecting one device to another, A is connected to A and B to B.

The cable shield is to be connected directly to ground (shield GND) in one point/device of the bus. Other devices connected to the bus should have the cable shield connected to ground via a capacitor (shield GND via capacitor).



Signal ground can only be used for balancing potential differences between devices/nodes if all devices connected to the bus have isolated RS-485 interfaces.

The RS-485 communication module is provided with jumpers for setting bus termination and fail-safe biasing. The bus is to be terminated at both ends, which can be done by using the internal termination resistor on the communication module. The termination resistor is selected by setting jumper X5 to the ON position. If the internal termination resistor of 120 Ω is used, the impedance of the cable should be the same.

The bus is to be biased at one end to ensure fail-safe operation, which can be done using the pull-up and pull-down resistors on the communication module. The pull-up and pull-down resistors are selected by setting jumpers X3 and X4 to the ON position.

The jumpers have been set to no termination (X5 in the OFF position) and no biasing (X3 and X4 in the OFF position) as default.

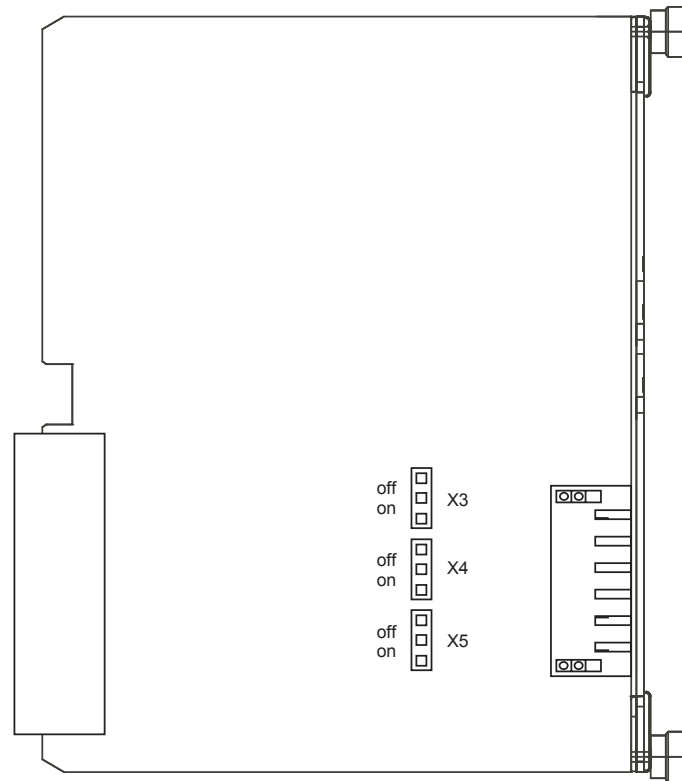

A040334

Fig. 5.2.2.-1 Jumper location on the RS-485 communication module

Table 5.2.2.-2 RS-485 rear connector

Terminal	Function
X5.5-6	Data A (+)
X5.5-5	Data B (-)
X5.5-4	Signal GND (for potential balancing)
X5.5-3	-
X5.5-2	Shield GND (via capacitor)
X5.5-1	Shield GND

Combined fibre-optic connection (plastic and glass)

If the relay is provided with the optional fibre-optic communication module for plastic and glass fibre, the plastic fibre-optic cables are connected to terminals X5.3-RX (Receiver) and X5.3-TX (Transmitter) and the glass fibre-optic cables to terminals X5.4-RX (Receiver) and X5.4-TX (Transmitter).

The fibre-optic interface is selected with jumpers X6 and X2 located on the PCB of the communication module (see Fig. 5.2.2.-2).

Table 5.2.2.-3 Transmitter selection

Transmitter	Position of jumper X6
Plastic	X5.3-TX
Glass	X5.4-TX

Table 5.2.2.-4 Receiver selection

Transmitter	Position of jumper X2
Plastic	X5.3-RX
Glass	X5.4-RX

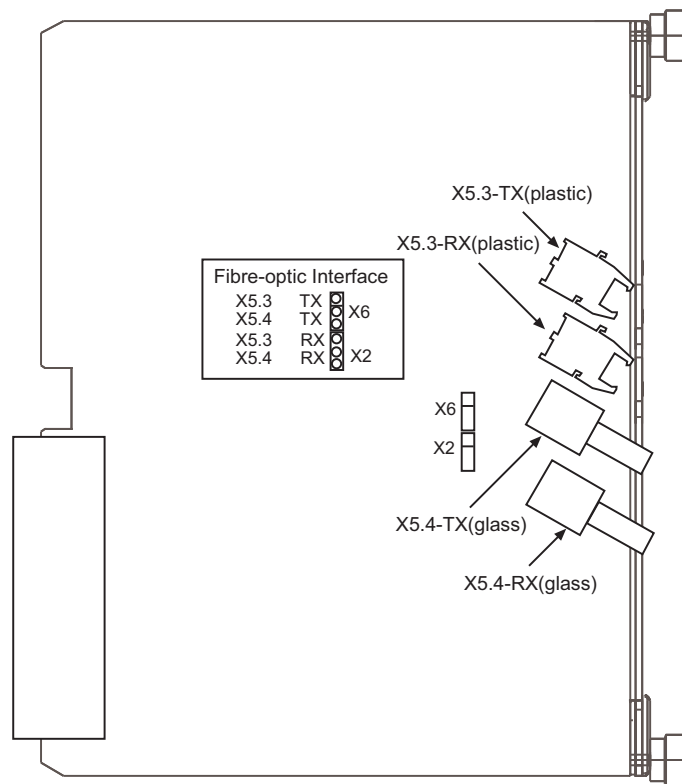

A040335

Fig. 5.2.2.-2 Jumper location on the communication module for plastic and glass fibre

Table 5.2.2.-5 Fibre-optic rear connectors (plastic and glass)

Terminal	Function
X5.3-TX	Transmitter for plastic fibre
X5.3-RX	Receiver for plastic fibre
X5.4-TX	Transmitter for glass fibre
X5.4-RX	Receiver for plastic fibre

5.2.3.

Technical data

Table 5.2.3.-1 Dimensions (for dimension drawings, refer to the Installation Manual)

Width, frame 177 mm, case 164 mm
Height, frame 177 mm (4U), case 160 mm
Depth, case 149.3 mm
Weight of the relay ~3.5 kg
Weight of the spare unit ~1.8 kg

Table 5.2.3.-2 Power supply

U _{aux} rated: -REM610CxxHxxx -REM610CxxLxxx	U _r = 100/110/120/220/240 V AC U _r = 110/125/220/250 V DC U _r = 24/48/60 V DC
U _{aux} variation (temporary): -REM610CxxHxxx -REM610CxxLxxx	85...110% of U _r (AC) 80...120% of U _r (DC) 80...120% of U _r (DC)
Burden of auxiliary voltage supply under quiescent (P _q)/operating condition	<9 W/13 W
Ripple in the DC auxiliary voltage	Max 12% of the DC value (at frequency of 100 Hz)
Interruption time in the auxiliary DC voltage without resetting the relay	<50 ms at U _{aux} rated
Time to trip from switching on the auxiliary voltage ^{a)}	<350 ms
Internal over temperature limit	+100°C
Fuse type	T2A/250 V

^{a)} Time to trip of element 50P and 51N.

Table 5.2.3.-3 Energizing inputs

Rated frequency	50/60 Hz ±5 Hz	
Rated current, I _n (CT)	1 A	5 A
Thermal withstand capability:		
• continuously	4 A	20 A
• for 1 s	100 A	500 A
• for 10 s	25 A	100 A
Dynamic current withstand:		
• half-wave value	250 A	1250 A
Input impedance	<100 mΩ	<20 mΩ

Table 5.2.3.-4 Measuring range

Measured currents on phases I _a , I _b and I _c as multiples of the rated currents of the energizing inputs	0...50 × I _n (CT)
Ground-fault current as a multiple of the rated current of the energizing input	0...8 × I _n (CT)

Table 5.2.3.-5 Digital inputs

Rated voltage:	DI1...DI2	DI3...DI5 (optional)
REM610CxxHxxx	110/125/220/250 V DC	
Activating threshold	Max. 88 V DC (110 V DC - 20%)	
REM610CxxLxxx	24/48/60/110/125/ 220/250 V DC	
Activating threshold	Max. 19,2 V DC (24 V DC - 20%)	
REM610CxxxxMx		24/48/60/110/125/ 220/250 V DC
Activating threshold		Max. 19,2 V DC (24 V DC -20%)
Operating range	±20% of the rated voltage	
Current drain	2...18 mA	
Power consumption/input	≤0.9 W	

Table 5.2.3.-6 Non-trip output SO1

Rated voltage	250 V AC/DC
Continuous carry	5 A
Make and carry for 3.0 s	15 A
Make and carry for 0.5 s	30 A
Breaking capacity when the control-circuit time constant L/R <40 ms, at 48/110/220 V DC	1 A/0.25 A/0.15 A
Minimum contact load	100 mA at 24 V AC/DC

Table 5.2.3.-7 Non-trip output SO2 and IRF output

Rated voltage	250 V AC/DC
Continuous carry	5 A
Make and carry for 3.0 s	10 A
Make and carry for 0.5 s	15 A
Breaking capacity when the control-circuit time constant L/R <40 ms, at 48/110/220 V DC	1 A/0.25 A/0.15 A
Minimum contact load	100 mA at 24 V AC/DC

Table 5.2.3.-8 Trip outputs (PO1, PO2, PO3)

Rated voltage	250 V AC/DC
Continuous carry	5 A
Make and carry for 3.0 s	15 A
Make and carry for 0.5 s	30 A
Breaking capacity when the control-circuit time constant L/R <40 ms, at 48/110/220 V DC (PO1 with both contacts connected in series)	5 A/3 A/1 A
Minimum contact load	100 mA at 24 V AC/DC
Trip-circuit supervision (TCS):	
• Control voltage range	20...265 V AC/DC
• Current drain through the supervision circuit	~1.5 mA
• Minimum voltage over a contact	20 V AC/DC (15...20 V)

Table 5.2.3.-9 Enclosure class of the flush-mounted relay

Front side	IP 54 Category 2
Rear side, top of the relay	IP 40
Rear side, connection terminals	IP 20

Table 5.2.3.-10 RTD/analog inputs

Supported RTD sensors	100 Ω platinum	TCR0.00385 (DIN 43760)
	250 Ω platinum	TCR 0.00385
	1000 Ω platinum	TCR 0.00385
	100 Ω nickel	TCR 0.00618 (DIN 43760)
	120 Ω nickel	TCR 0.00618
	120 Ω nickel (US)	TCR 0.00672
	10 Ω copper	TCR 0.00427
Supported PTC thermistor range	0...20 kΩ	
Maximum lead resistance (three-wire measurement)	200 Ω per lead	
Isolation	2 kV (inputs to protective earth)	
Sampling frequency	5 Hz	
Response time	<8 s	
RTD/Resistance sensing current	Maximum 4.2 mA rms 6.2 mA rms for 10Ω copper	

Table 5.2.3.-11 Environmental tests and conditions

Recommended service temperature range (continuous)	-10...+55°C
Humidity	< 95% RH
Limit temperature range (short-term)	-40...+70°C
Transport and storage temperature range	-40...+85°C according to IEC 60068-2-48
Dry heat test (humidity <50%)	According to IEC 60068-2-2

Technical Reference Manual - ANSI Version

Dry cold test	According to IEC 60068-2-1
Damp heat test, cyclic (humidity >93%)	According to IEC 60068-2-30
Atmospheric pressure	86...106 kPa

Table 5.2.3.-12 Electromagnetic compatibility tests

EMC immunity test level meets the requirements listed below:	
1 MHz burst disturbance test, class III • Common mode • Differential mode	According to IEC 60255-22-1, IEC 61000-4-18 2.5 kV 1.0 kV
Electrostatic discharge test, class IV • For contact discharge • For air discharge	According to IEC 61000-4-2, IEC 60255-22-2 and ANSI C37.90.3-2001 8 kV 15 kV
Radio frequency interference tests: • Conducted, common mode	According to IEC 61000-4-6 and IEC 60255-22-6 (2000) 10 V (rms), f = 150 kHz...80 MHz
• Radiated, amplitude-modulated • Radiated, pulse-modulated	According to IEC 61000-4-3 and IEC 60255-22-3 (2000) 10 V/m (rms), f = 80...1000 MHz According to the ENV 50204 and IEC 60255-22-3 (2000) 10 V/m, f = 900 MHz
Fast transient disturbance tests • Trip outputs, energizing inputs, power supply • I/O ports	According to IEC 60255-22-4 and IEC 61000-4-4 4 kV 2 kV
Surge immunity test • Trip outputs, energizing inputs, power supply • I/O ports	According to IEC 61000-4-5 and IEC 60255-22-5 4 kV, line-to-ground 2 kV, line-to-line 2 kV, line-to-ground 1 kV, line-to-line
Power frequency (50 Hz) magnetic field IEC 61000-4-8	300 A/m continuous
Power frequency immunity test: REM610CxxHxxx • Common mode • Differential mode REM610CxxLxxx and REM610CxxxxMx • Common mode • Differential mode	According to IEC 60255-22-7 and IEC 61000-4-16 Class A 300 V rms 150 V rms Class B 300 V rms 100 V rms
Voltage dips and short interruptions	According to IEC 61000-4-11 30%/10 ms 60%/100 ms 60%/1000 ms

	>95%/5000 ms
Electromagnetic emission tests	According to the EN 55011
• Conducted, RF-emission (Mains terminal)	EN 55011, class A, IEC 60255-25
• Radiated RF-emission	EN 55011, class A, IEC 60255-25
CE approval	Complies with the EMC directive EMC 2004/108/EC and the LV directive LV 2006/95/EC

Table 5.2.3.-13 Standard tests

Insulation tests:	
Dielectric tests	According to IEC 60255-5
• Test voltage	2 kV, 50 Hz, 1 min
Impulse voltage test	According to IEC 60255-5
• Test voltage	5 kV, unipolar impulses, waveform 1.2/50 μ s, source energy 0.5 J
Insulation resistance measurements	According to IEC 60255-5
• Isolation resistance	>100 M Ω , 500 V DC
Mechanical tests:	
Vibration tests (sinusoidal)	According to IEC 60255-21-1, class I
Shock and bump test	According to IEC 60255-21-2, class I

Table 5.2.3.-14 Data communication

Rear interface:
• Fibre-optic or RS-485 connection
• SPA bus, IEC 60870-5-103, DNP 3.0 or Modbus protocol
• 9.6 or 4.8 kbps (additionally 2.4, 1.2 or 0.3 kbps for Modbus)
Front interface:
• Optical connection (infrared): wirelessly or via the front communication cable (1MRS050698)
• SPA bus protocol
• 9.6 or 4.8 kbps (9.6 kbps with front communication cable)

Optional communication modules and protocols

- SPA-bus, IEC 60870-5-103, Modbus® (RTU and ASCII):
 - Plastic fibre
 - Plastic and glass fibre
 - RS485

Auxiliary voltage

The relay requires a secured auxiliary voltage supply to operate. The internal power supply of the relay forms the voltages required by the relay electronics. The power supply is a galvanically isolated (flyback-type) DC/DC converter. When the auxiliary voltage is connected, the green target LED (ready) on the front panel is lit. For detailed information on power supply, refer to Table 5.2.3.-2.

The primary side of the power supply is protected with a fuse located on the printed circuit board of the relay.

6. Application examples

6.1. Setting calculations

6.1.1. Protected unit scaling factor

The FLA secondary scaling factor for phase currents is calculated as follows:

$$\text{FLA secondary scaling factor} = \frac{I_{N1}}{I_{NM}} \times \frac{I_{NR}}{I_{N2}} \quad (5)$$

I_{N1} = rated primary current of the CT

I_{N2} = rated secondary current of the CT

I_{NM} = rated current of the motor

I_{NR} = rated current of the relay

The rated current of the protected unit, I_n , equals the FLA of the motor provided that the protected unit scaling factor has been properly set. The rated current of the protected unit will equal that of the CT when the factor is 1.

Example:

Rated power, P_{nm}	4500 kW
Rated voltage, U_{nm}	3300 V
Rated current, I_{nm}	930 A
CT current ratio, I_{N1}/I_{N2}	1000/5 A
Relay input, I_{NR}	5:00 AM

The FLA secondary scaling factor is calculated as follows: $1000 \text{ A}/930 \text{ A} \times 5 \text{ A}/5 \text{ A} = 1.075 \approx 1.08$

Example:

Rated power, P_{nm}	900 kW
Rated voltage, U_{nm}	380 V
Rated current, I_{nm}	1650 A
CT current ratio	2000/1 A
Relay input	1:00 AM

The FLA secondary scaling factor is calculated as follows: $2000 \text{ A}/1650 \text{ A} \times 1 \text{ A}/1 \text{ A} = 1.212 \approx 1.21$

6.1.2. Thermal overload protection

The FLA of the motor at an ambient temperature of 40°C determines the highest permissible continuous load. In this case, an increase of five per cent in the motor current will eventually cause a trip.



If the settings of the thermal overload protection have been defined by means of the FLA of the motor instead of the internal FLA, they will be valid at an ambient temperature of 40°C.

For how the ambient temperature is used to determine the internal FLA, refer to Section 5.1.4.2. Thermal overload protection.

6.1.2.1.

Selecting weighting factor p

Setting p to 100 per cent creates a pure single time constant thermal protection for protecting cables, for instance. In this case, the allowed stall time will be only approximately ten per cent of the safe stall time, t_{6x} , when no prior load; see Fig. 6.1.2.1.-1. At a set safe stall time of twenty seconds, the operate time when the prior load is 1 x FLA will be only two seconds, even though the motor can withstand a stall time of five seconds, for instance. To allow the use of the motor's full capacity, a lower weighting factor should be used.

Normally, approximately half of the thermal capacity is used when a motor is running at full load. By setting p to 50 per cent, the thermal overload protection will take this into account.

In special cases where the thermal overload protection is required to follow the characteristics of the object to be protected more closely and the thermal capacity of the object is very well known, a value between 50 and 100 per cent may be required.

In applications where, for instance, three cold starts vs two hot starts are allowed, setting the weighting factor to 40 per cent has at times proved useful.



Setting the weighting factor to significantly below 50 per cent may overload the object to be protected as the thermal overload protection may allow too many hot starts or the thermal history of the motor has not sufficiently been taken into account.

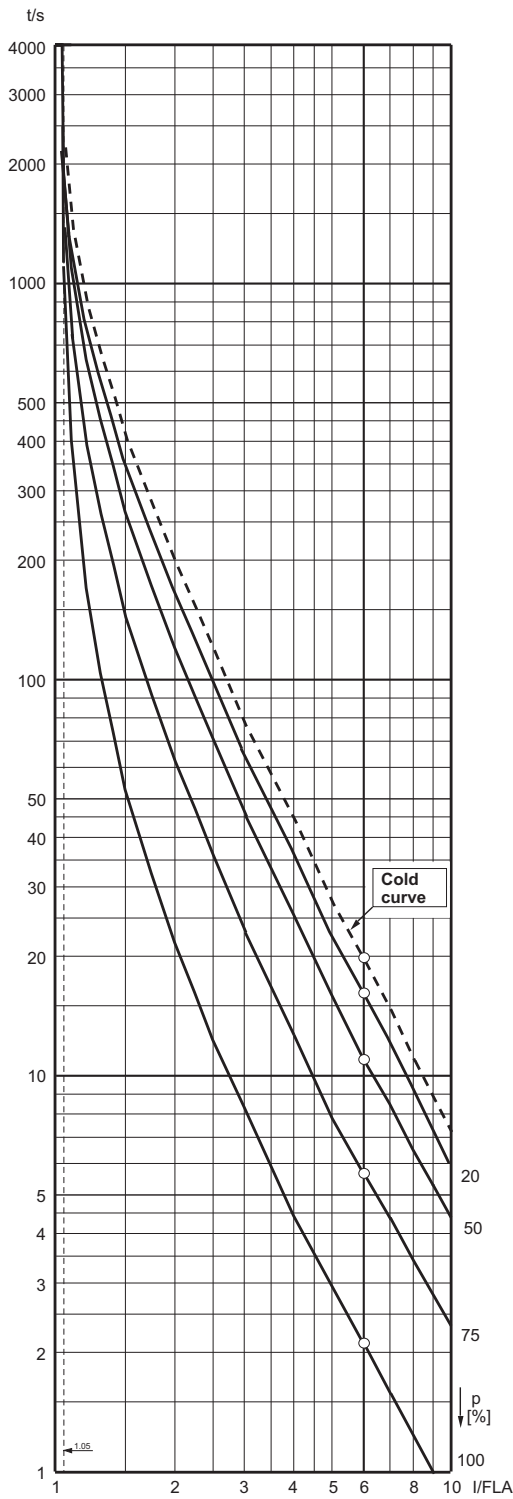

A070814

Fig. 6.1.2.1.-1 The influence of p at prior load $1 \times FLA$ and $t_{6\alpha} = 20 \text{ s}$

6.1.2.2. Safe stall time for hot starts

The safe stall time setting, t_{6x} , is determined according to the start-up time of the motor. The safe stall time can easily be determined from the trip curves at prior load 1 x FLA.

Normally, the safe stall time setting is selected to allow one hot or two cold starts. The appropriate trip curve is selected by means of the start-up current and start-up time (and margin) of the motor. If multiple hot starts are allowed, the total start-up time instead of a single start-up time is to be used.

The safe stall time setting can be calculated as follows:

$$t_{6x} = \frac{t}{32.15 \times \ln \left\{ \frac{\left(\frac{I_{start}}{FLA_{int}} \right)^2 - \frac{p}{100} \times \left(\frac{I_{prior}}{FLA_{int}} \right)^2}{\left(\frac{I_{start}}{FLA_{int}} \right)^2 - 1.1025} \right\}} \tag{6}$$

- t = required operate time (i.e the number of hot starts x start-up time of the motor and margin)
- ln = natural logarithm
- I_{start} = start-up current of the motor
- FLA_{int} = internal FLA (equals the FLA of the motor at an ambient temperature of 40°C)
- p = weighting factor
- I_{prior} = prior load current (normally equal to the FLA of the motor).



Cooling between starts is not considered in the formula above.

The operate time with the selected safe stall time setting can be calculated as follows:

$$\text{operate time} = 32.15 \times t_{6x} \times \ln \left\{ \frac{\left(\frac{I_{start}}{FLA_{int}} \right)^2 - \frac{p}{100} \times \left(\frac{I_{prior}}{FLA_{int}} \right)^2}{\left(\frac{I_{start}}{FLA_{int}} \right)^2 - 1.1025} \right\} \tag{7}$$

Example:

Start-up current of the motor	6.2 x FLA
Start-up time of the motor	11 s
One hot start allowed	
Ambient temperature	40°C

At an ambient temperature of 40°C the internal FLA equals the FLA of the motor. Thus, the start-up current of the motor is 6.2 x the internal FLA.

The safe stall time setting is calculated or selected from the trip curves at prior load 1 x FLA. In the figure below, a safe stall time of 30 seconds is selected, permitting a start-up time slightly longer than the one stated by the motor manufacturer; see the figure below.

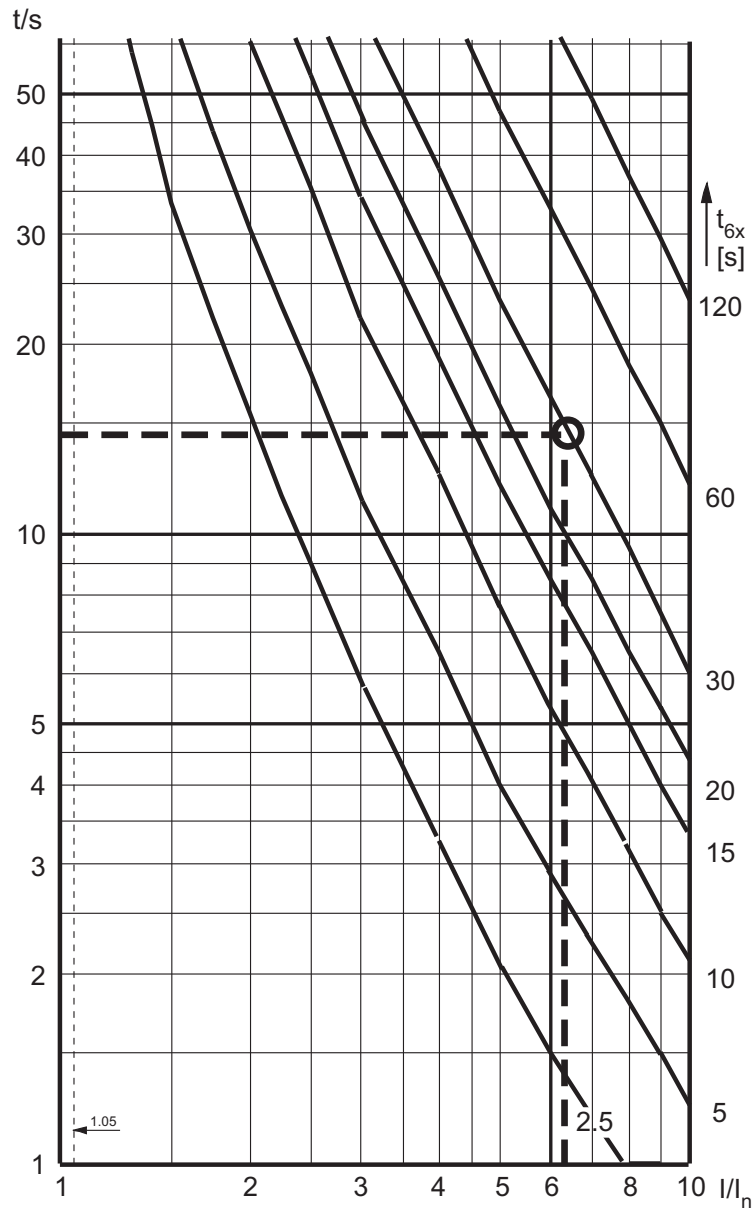

A051487

Fig. 6.1.2.2.-1 Selected safe stall time 30 s

Example:

Start-up current of the motor	6.2 x FLA
Start-up time of the motor	11 s
One hot start allowed	
Ambient temperature	20°C

At an ambient temperature of 20°C the internal FLA is 1.09 x FLA of the motor. Thus, the start-up current of the motor is 6.2/1.09 = 5.69 x the internal FLA.

In this case, a safe stall time setting of 23 seconds is selected from the trip curves at prior load 1 x FLA, permitting a start-up time slightly longer than the one stated by the motor manufacturer; see the figure below.

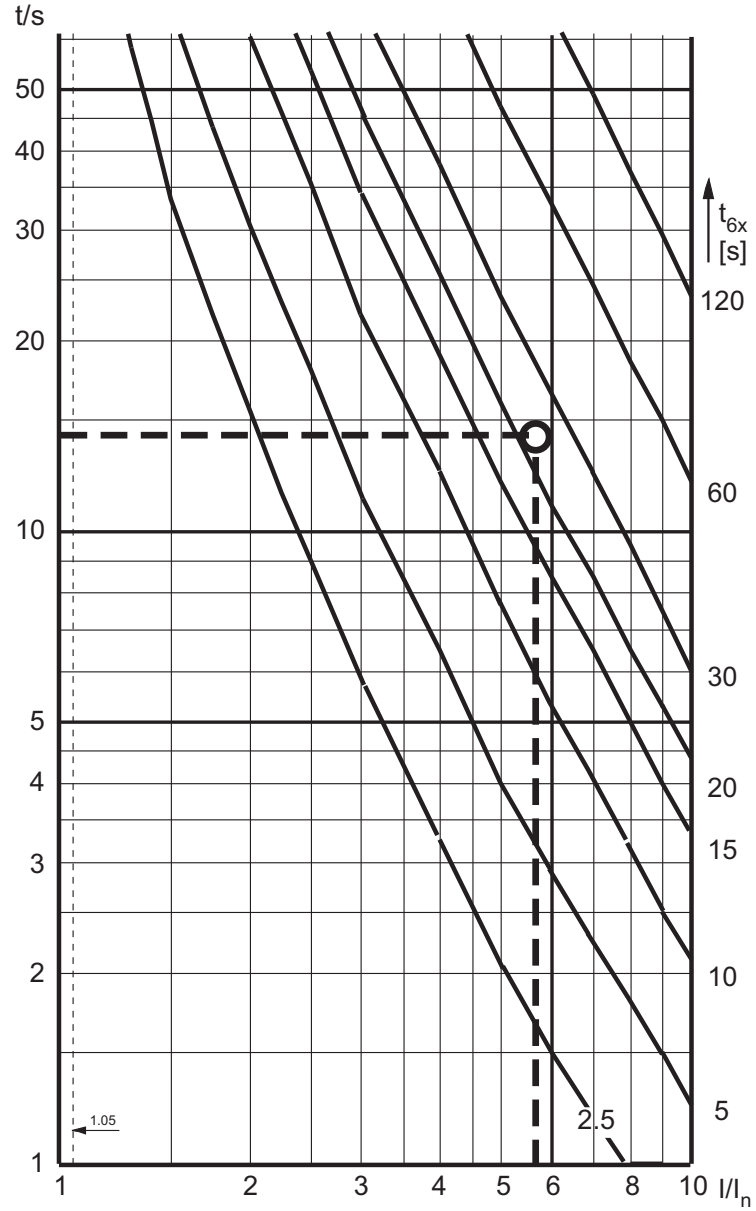

Fig. 6.1.2.2.-2 Selected safe stall time 23 s

A051488

Example:

Start-up current of the motor 6.2 x FLA
Start-up time of the motor 11 s
One hot start allowed
Ambient temperature 40°C

At an ambient temperature of 40°C the internal FLA equals the FLA of the motor. Thus, the start-up current of the motor is 6.2 x the internal FLA.

In Fig. 5.1.2.2.-3, a safe stall time setting of 60 seconds is selected from the trip curves at prior load 1 x FLA, permitting a start-up time slightly longer than twice the one stated by the motor manufacturer; see the figure below.

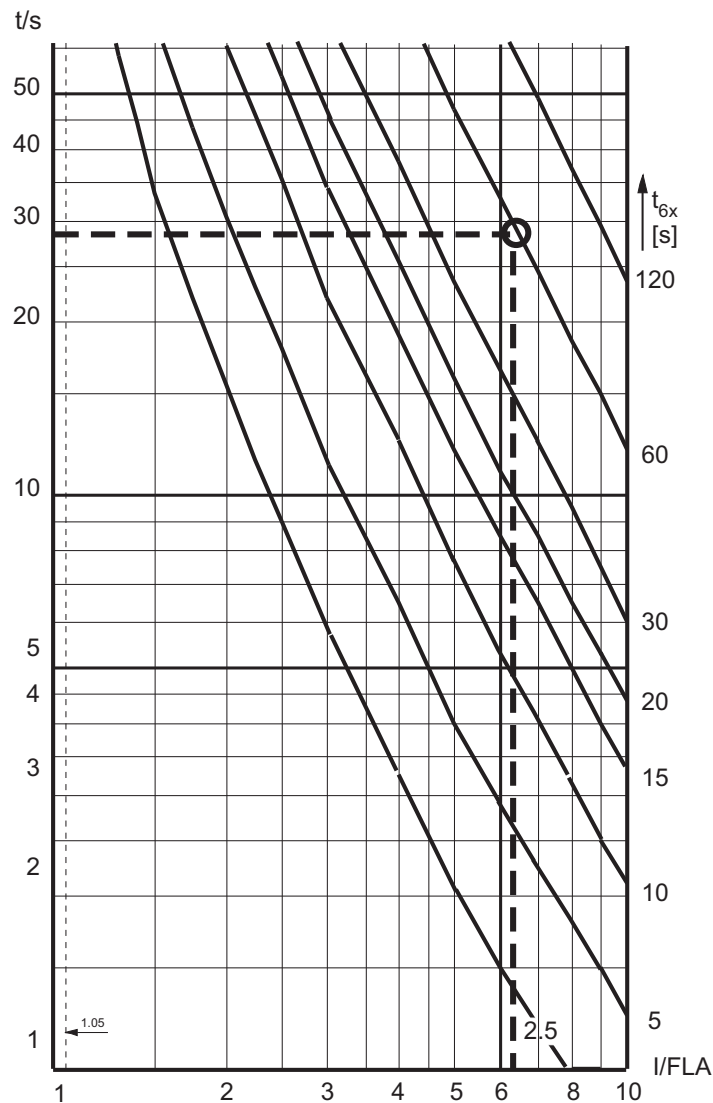

Fig. 6.1.2.2.-3 Selected safe stall time 60 s

A070815

6.1.2.3. Checking the set safe stall time for cold starts

By selecting the correct trip curve from the trip curves at no prior load according to the previously selected or calculated safe stall time setting, the total start-up time of the motor can be read from the curve. The total start-up time should permit as many cold starts as stated by the motor manufacturer.

In applications where, for instance, three cold vs two hot starts are allowed, the total start-up time of the motor may allow too many cold starts. In this case, the thermal protection can be supplemented by using the cumulative start-up time counter for limiting the number of cold starts. Alternatively, setting the weighting factor to 40 per cent, instead of to 50 per cent, has at times proved useful.

The operate time when no prior load with the selected safe stall time setting can also be calculated as follows:

$$\text{operate time} = 32.15 \times t_{6x} \times \ln \left[\frac{\left(\frac{I_{start}}{FLA_{int}} \right)^2}{\left(\frac{I_{start}}{FLA_{int}} \right)^2 - 1.1025} \right] \quad (8)$$

6.1.2.4. Checking the set safe stall time for a single start

If the safe stall time of the motor is shorter than the operate time when no prior load, a single motor start up should instead be protected by the start-up supervision.

6.1.2.5. Restart disable level, 49 RESTDIS

The restart disable level can be calculated as follows:

$$49 \text{ RESTDIS} = \left(100\% - \left(\frac{\text{start-up time of the motor}}{\text{operate time when no prior load}} \times 100\% + \text{margin} \right) \right)^{(9)}$$

For instance, if the start-up time of the motor is 11 seconds and the calculated operate time of the thermal protection element when no prior load 25 seconds, one motor start up will use $11 \text{ s} / 25 \text{ s} = 45\%$ of the thermal capacity of the motor. Therefore, the restart disable level must be set to below $100\% - 45\% = 55\%$, e.g. to 50%.

6.1.2.6. Prior alarm level, 49 ALARM

Tripping due to a beginning overload can be avoided by reducing the load of the motor at a prior alarm.

The prior alarm level can be set to a level, which will allow the use of the motor's full thermal capacity without causing a trip due to long-time overload.

Generally, the prior alarm level is set to 80...90 per cent of the trip level.

6.1.2.7. Time constant dial, K_c

The time constant dial, K_c , is the ratio of the cooling time (at motor standstill) and the heating time constant:

$$K_c = \frac{\tau_{cooling}}{\tau_{heating}} \quad (10)$$

Generally, the time constant dial of the motor is set to 4..6. However, when protecting non-rotating objects, e.g. feeder cables or transformers, for instance, the time constant dial is generally set to one.

6.1.3. Start-up supervision

Start-up supervision is based on thermal stress calculation by default but can also be set to be based on definite-time overcurrent protection, especially in other than motor applications.

6.1.3.1. Start-up supervision based on thermal stress calculation

The start-up current, 48/14 PICKUP, is set to equal the start-up current of the motor and the start-up time, 48/14 TDLY, to approximately ten per cent above the start-up time of the motor in order to leave a safety margin for operation.

For instance, if the start-up current of the motor is 6.2 x FLA and the start-up time 11 seconds, 48/14 PICKUP = 6.2 and 48/14 TDLY = 11 s x 1.1 = 12 s.

6.1.3.2. Checking the need for speed switch

When protecting motors of ExE-type, for instance, the safe stall time may be shorter than the start-up time of the motor, which is why a speed switch on the motor shaft is required to give information on whether the motor is accelerating during motor start up. In this case, the start-up time is set to slightly below the safe stall time.

The speed switch should be open at standstill and closed during acceleration. When the input is activated, element $(48/14 \text{ PICKUP})^2 \times (48/14 \text{ TDLY}) / (48/14)$ will be blocked. If the motor does not start to accelerate, element $(48/14 \text{ PICKUP})^2 \times (48/14 \text{ TDLY})$ will trip when the reference value, $(48/14 \text{ PICKUP})^2 \times (48/14 \text{ TDLY})$, is exceeded. If start-up supervision is based on overcurrent protection, element 48/14 will trip on expiration of the set operate time

However, if the safe stall time is longer than the start-up time of the motor when no prior load, a speed switch will not be required.

6.1.4. Cumulative start-up time counter

The cumulative start-up time counter functions as backup to the thermal overload protection and prevents too frequent motor start ups, i.e. ensures that the recommendations from the manufacturer are followed.

There are two values to set: the restart disable value in seconds, 66, and the countdown rate of the start-up time counter, 66 COOL/ Δt .

The restart disable value is calculated as follows:

$$66 = (n - 1) \times t + \text{margin} \quad (11)$$

n = allowed number of motor start ups
 t = start-up time of the motor (in seconds)
 margin = safety margin (~10... 20%)

The countdown rate is calculated as follows:

$$66\text{COOL} = \frac{t}{t_{\text{reset}}} \quad (12)$$

t = start-up time of the motor (in seconds)
 t_{reset} = time during which the maximum number of motor start ups stated by the manufacturer can be made (in hours)

If the motor manufacturer has recommended a maximum of three start ups in four hours and a start-up time of 60 seconds/start up, the restart disable will be activated when the third motor start up has been initiated, thus preventing a fourth motor start up. Consequently, the restart disable value is to be set to 130 seconds.

A maximum of three motor start ups in four hours means that the register's value should reach the set restart disable value four hours later to allow a new motor start up. Consequently, the register's value should decrease by 60 seconds in four hours, i.e. $66 \text{ Cool} / \Delta = 60 \text{ s} / 4\text{h} = 15 \text{ s/h}$.

6.1.5. Short-circuit protection

It is recommended that the set pickup value of element 50P is set to be automatically doubled during motor start up. Consequently, a pickup value lower than the start-up current of the motor can be selected.

A pickup value of 70%...90% x the start-up current of the motor is normally selected. This low a set pickup value together with a suitable set operate time will enable tripping of the high-set overcurrent element if overcurrent due to a locked rotor, for instance, is detected while the motor is running.

Generally, a set pickup value as low as 75% of the start-up current of the motor has proved useful, but if the inrush current causes tripping during motor start up, a higher set pickup value will be required.

6.1.6. Unbalance and phase reversal protection

The pickup value of the unbalance element, 46, is the NPS current which the motor can continuously withstand without being damaged. The time constant, 46 TDIAL, equals the motor constant, $I_2^2 \times t$, i.e. it determines the rotor’s ability to withstand heating caused by the NPS current.

The unbalance and the phase reversal protection element can be separately selected or set out of operation. The phase reversal protection should be set out of operation in applications where the motor rotates in the opposite direction.

6.1.6.1. Selecting the pickup value for element 46

The pickup value of element 46 is selected as stated by the motor manufacturer. If the maximum allowed NPS voltage and not the current is stated, the NPS current will be approximately the same as the product of the NPS voltage and the ratio of the start-up current and the FLA of the motor.

For instance, if the start-up current of the motor is 6 x FLA and the maximum allowed NPS voltage four per cent, the estimated NPS current will be 6 x 4% = 24%. Thus, 46 PICKUP will be 0.24 x FLA.

6.1.6.2. Selecting the time constant, 46 TDIAL

The time constant 46 TDIAL can be estimated as follows:

$$46 \text{ TDIAL} = \frac{175}{(I_{start})^2} \tag{13}$$

I_{start} = start-up current of the motor x FLA

For instance, if the start-up current of the motor is 5 x FLA, the estimated time constant will be $175/5^2 = 7$.

The operate time of the unbalance element should be set to be shorter than the safe stall time stated by the motor manufacturer in case a phase is lost.

6.1.6.3. Connection with two phase current transformers

If two-phase connection is used, it is recommended that a current corresponding to the sum of these two phases is connected to the input circuit of the missing phase; see Fig. 6.1.6.3.-1. This has two advantages: the unbalance element does not have to be set out of operation and the current measurement is more accurate compared to two-phase measurement.

However, an ground-fault current may affect the unbalance measurement. Therefore, it is recommended that the unbalance protection is used to protect the motor against single-phasing only.

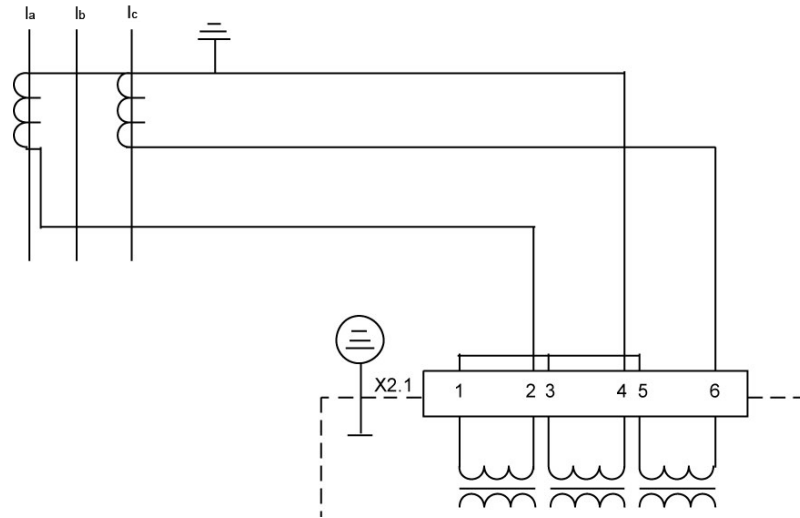

A070089

Fig. 6.1.6.3.-1 Connection with two phase current transformers

6.1.7. Ground-fault protection

In solidly or low-resistance grounded networks, the ground-fault current can be derived from the line CTs, provided that the CTs have been residually connected. In this case, the operate time of the ground-fault element is typically set to be short, e. g. 50 ms.

To avoid damaging the contactor in a contactor controlled drive, the ground-fault element can be set to be disabled when one or several phase currents exceed the FLA of the motor four, six or eightfold. This can also be done to ensure that the ground-fault protection will not trip even though the line CTs would partially saturate during a motor start up. The pickup value of the ground-fault element is typically set to 15...40% FLA.

A core balance transformer is recommended for isolated neutral networks and high resistance grounded networks. The use of a core balance transformer makes the ground-fault protection very sensitive and the variations in the load current will not affect the ground-fault measurement. Consequently, a relatively low pickup value can be selected in high resistance grounded networks.

The transformation ratio of the core balance transformer can be freely selected according to the ground-fault current, and consequently, the sensitivity of the ground-fault protection as well. Due to the extremely low burden of the relay, low transformation ratios may be used in cable current transformers, in KOLMA type transformers even as low as 10/1 A. However, a transformation ratio of at least 50/1 A or 100/1 A is recommended.

The pickup value of the ground-fault element is typically selected to be 5...30% I_n of the fully developed ground-fault current and the operate time to be 0.5...2 seconds.

If a residual connection is preferred, the pickup value and operate time must be set slightly higher in order to avoid possible stability problems due to unbalance in the main transformers, as the unbalance will cause virtual ground-fault currents during high phase current conditions. Also, an external stabilizing resistor can be used to compensate too weak main transformers, thus preventing them from causing ground-fault currents.

6.1.7.1. Stabilizing virtual ground-fault currents

An apparent ground-fault current caused by the difference between the phase current transformers connected in parallel may cause nuisance trippings of the ground-fault element, especially during an overload. This can be avoided by using a stabilizing resistor in the ground-fault current circuit. The continuous power withstand of the resistor can be 30 W, for instance. The resistance value can be, for instance, 100 Ω when the 1 A input is used and 10 Ω when the 5 A input is used. The value of the knee-point voltage must be checked and should be $>2 \times U_{stab}$. The stabilizing resistor will also slightly reduce the ground-fault sensitivity.

6.1.7.2. Increasing the sensitivity of the ground-fault protection

The sensitivity of the ground-fault protection can be increased by using a relay provided with a 1 A input instead of one with a 5 A input. This is possible in a solidly grounded network as well, because the thermal withstand capability of the current input is normally high enough.

6.1.8. Circuit-breaker failure protection

The operate time of the CBFAIL should be set to be longer than the circuit-breaker opening time + the resetting time of the protection element with the longest resetting time, with the exception of the thermal, temperature and phase reversal protection elements and the external trip.

6.1.9. Temperature protection (optional)

Tripping due to a beginning thermal overload can be avoided by reducing the load of the motor at an alarm of element 49/38-1/49/38-2.

6.2. Protecting a circuit-breaker controlled motor

Data of the squirrel cage motor stated by the manufacturer:

Rated power, P_{nm}	4500 kW
Rated voltage, U_{nm}	3300 V
Rated current, I_{nm}	930 A
Start-up current of the motor	6.2 x FLA
Start-up time of the motor	11 s
Safe stall time	19 s
Ambient temperature	40°C
CT current ratio	1000/5 A (relay input = 5 A)

Setting calculations

The protected unit scaling factor is calculated as follows:

$$\frac{1000A}{930A} \times \frac{5A}{5A} = 1.075 \approx 1.08 \quad (14)$$

For a direct-on-line started motor, $p = 50\%$.

At an ambient temperature of 40°C the internal FLA equals the FLA of the motor. Thus the start-up current of the motor is 6.2 x the internal FLA.

The safe stall time setting, t_{6x} , is calculated or selected from the trip curves at prior load 1 x FLA. A safe stall time setting of 30 seconds is selected, permitting a start-up time slightly longer than the one stated by the motor manufacturer.

By selecting the correct trip curve from the trip curves at no prior load according to the previously selected or calculated safe stall time setting, the total start-up time of the motor can be read from the curve. In this case, the thermal protection element will trip in approximately 28 seconds, which will allow two cold starts.

However, as the operate time when no prior load is longer than the safe stall time of nineteen seconds, single motor start ups should instead be protected by the start-up supervision. The start-up current, 48/14 PICKUP, is set to equal the start-up current of the motor and the start-up time, 48/14 TDLY, to approximately ten per cent above the start-up time of the motor in order to leave a safety margin for operation. Thus 48/14 TDLY is set to $1 \text{ s} \times 1.1 \approx 12 \text{ s}$.

As the safe stall time is longer than the start-up time of the motor, no speed switch will be required.

As one motor start up uses $11 \text{ s}/28 \text{ s} \approx 39\%$ of the thermal capacity of the motor, the restart disable level, 49 RESTDIS, should be set to below 61 per cent, e.g. to 55 per cent.

The prior alarm level, 49 ALARM, is set to 80...90 per cent of the trip level.

The time constant multiplier, K_c , is set to 4.

If the pickup value of element 50P is set to be doubled during motor start up (SGF3/8=1), the pickup value should be set below the start-up current of the motor, i.e to 75...90% x the start-up current of the motor: $50P = 0.75 \times 6.2 \approx 4.65$.

6.3. Protecting a motor at an ambient temperature other than 40°C

Data of the squirrel cage motor stated by the manufacturer:

Rated power, P_{nm}	4500 kW
Rated voltage, U_{nm}	3300 V
Rated current, I_{nm}	930 A
Start-up current of the motor	6.2 x FLA
Start-up time of the motor	11 s
Safe stall time	19 s
Ambient temperature	20...70°C
CT current ratio	1000/5 A (relay input = 5 A)

Setting calculations

The protected unit scaling factor is calculated as follows:

$$\frac{1000A}{930A} \times \frac{5A}{5A} = 1.075 \approx 1.08 \tag{15}$$

For a direct-on-line started motor, $p = 50\%$.

At an ambient temperature of 40°C the internal FLA is 1.0 x FLA of the motor. Thus, the start-up current of the motor is 6.2 x the internal FLA. A safe stall time of 30 seconds is selected as in the previous application example.

If the ambient temperature is lower than 40°C, the motor can be run at a slight overload in relation to the specified maximum load at 40°C. If the ambient temperature is higher than 40°C, the continuous load must be lower than the specified maximum load at 40°C.

At an ambient temperature of 20°C the internal FLA is 1.09 x FLA of the motor. Thus, the start-up current of the motor is $6.2/1.09 = 5.69$ x the internal FLA. If a safe stall time setting of 30 seconds is selected, the relay will allow two hot starts instead of one. If this is unacceptable, however, and only one hot start is to be allowed, a safe stall time setting of 23 seconds is to be selected instead.

At an ambient temperature of 65°C the internal FLA is 0.75 x the FLA of the motor. Thus, the start-up current of the motor is $6.2/0.75 = 8.27$ x the internal FLA. If a safe stall time setting of 30 seconds and a prior load of 0.75 x the FLA of the motor are selected, the relay will not allow a hot start until the motor has been at standstill for several minutes. However, if a hot start is to be allowed, a safe stall time setting of approximately 50 seconds is to be selected instead.

All other settings are as in the previous application example.

6.4. Protecting a contactor controlled motor

Data of the squirrel cage motor stated by the manufacturer:

Rated power, P_{nm}	900 kW
Rated voltage, U_{nm}	380 V
Rated current, I_{nm}	1650 A
Start-up current of the motor	$6.0 \times I_{nm}$
Two cold starts allowed	
Start-up time of the motor	9 s
Safe stall time	21 s
Ambient temperature	50°C
CT current ratio	2000/5 A (relay input = 5 A)

Setting calculations

The protected unit scaling factor is calculated as follows:

$$\frac{2000A}{1650A} \times \frac{5A}{5A} = 1.212 \approx 1.21 \quad (16)$$

For a direct-on-line started motor, $p = 50\%$.

At an ambient temperature of 50°C the internal FLA is $0.9 \times$ FLA of the motor. Thus, the start-up current of the motor is $6.0/0.9 = 6.67 \times$ the internal FLA.

The safe stall time setting, t_{6x} , is calculated or selected from the trip curves at prior load $1 \times$ FLA. A safe stall time setting of 25 seconds is selected, permitting a start-up time slightly longer than the one stated by the motor manufacturer.

By selecting the correct trip curve from the trip curves at no prior load according to the previously selected or calculated safe stall time setting, the total start-up time of the motor can be read from the curve. In this case, the thermal protection element will trip in approximately 20 seconds, which will allow two cold starts.

As the operate time when no prior load is shorter than the safe stall time of 21 seconds, no start-up supervision will be required to protect the motor against single start ups. Still, start-up supervision is recommended in order to shorten the operate time in case of a locked rotor condition.

The start-up current, 48/14 PICKUP, is set to equal the start-up current of the motor and the start-up time, 48/14 TDLY, to approximately ten per cent above the start-up time of the motor in order to leave a safety margin for operation. Thus 48/14 TDLY is set to $9 \text{ s} \times 1.1 \approx 10 \text{ s}$.

As the safe stall time is longer than the start-up time of the motor, no speed switch will be required.

As one motor start-up uses $9\text{ s}/20\text{ s} \approx 45\%$ of the thermal capacity of the motor, the restart disable level, 49 REDIS, should be set to below 55 per cent, e.g. to 50 per cent.

The prior alarm level, 49 ALARM, is set to 80...90 per cent of the trip level.

The time constant multiplier, K_c , is set to 4...6.

The high-set overcurrent element should be set out of operation to prevent the contactor in a contactor controlled drive from operating at too high phase currents. In addition, to avoid damaging the contactor, the ground-fault element should be set to be disabled when one or several phase currents exceed the FLA of the motor sixfold ($SGF4/1 = 1, SGF4/2 = 0$). During high phase current conditions the protection will be based on the backup fuses.

6.5. Protecting non-rotating objects

In other than motor applications, start-up supervision is usually set to be based on definite-time overcurrent protection ($SGF3/6=1$) or on thermal stress calculation (pickup criterion $I_p > 48/14\text{ PICKUP}$). If start-up supervision is set to be based on thermal stress calculation ($SGF3/6=0$) and element $(48/14\text{ PICKUP})^2 \times (48/14\text{ TDLY})$ is set to pickup when one or several phase currents exceed the set pickup value ($SGF3/7=1$), the tripping of element $(48/14\text{ PICKUP})^2 \times (48/14\text{ TDLY})$ will be similar to that at the IDMT characteristic “extremely inverse”.

If a core balance transformer is used for measuring the ground-fault current, refer to Section 6.1.7. Ground-fault protection .

When protecting objects without hot spot tendencies, weighting factor p is set to 100 per cent. When setting t_{6x} , the expression $\tau = 32.15 \times t_{6x}$ can be used.

Usually, the time constant multiplier, K_c , is set to 1.

6.6. Ground-fault protection in an isolated or a compensated network

Data of the motor stated by the manufacturer:

Network ground-fault current at fully developed ground-fault	10 A isolated network
Required ground-fault sensitivity	20% (=2A)

Due to the high sensitivity required, a residual connection cannot be used, but instead, a core balance transformer with a CT ratio of 100/1.

The pickup value of element 51N is calculated as follows:

$$20\% \times 10A \times \frac{1A}{100A} = 2\% \times 1A \tag{17}$$

Thus, $51N = 2\%$ and the 1A input is used.

6.7. Ground-fault protection in a solidly grounded network

Data of the motor stated by the manufacturer:

Rated current, I_{nm}	1650 A
CT current ratio	2000/5 A (relay input = 5 A)
Required ground-fault sensitivity	20% I_{nm}

The pickup value of element 51N is calculated as follows:

$$20\% \times 1650 A \times \frac{5 A}{2000 A} = 16\% \times 5 A \quad (18)$$

Thus, 51N = 16% and the 5A input is used.

The operate time of the ground-fault element is set to 50 ms when the network is solidly grounded.

If the drive is contactor controlled, refer to Section 6.4. Protecting a contactor controlled motor.

7. Ordering information

When ordering protection relays and/or accessories, specify the following:

- Order number
- HMI language set number
- Quantity

The order number identifies the protection relay type and hardware as described in the figures below and is labelled on the marking strip under the lower handle of the relay.

Use the ordering key information in Fig. 7.-1 to generate the order number when ordering complete protection relays.

REM610C55HCMP 01

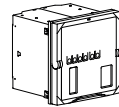
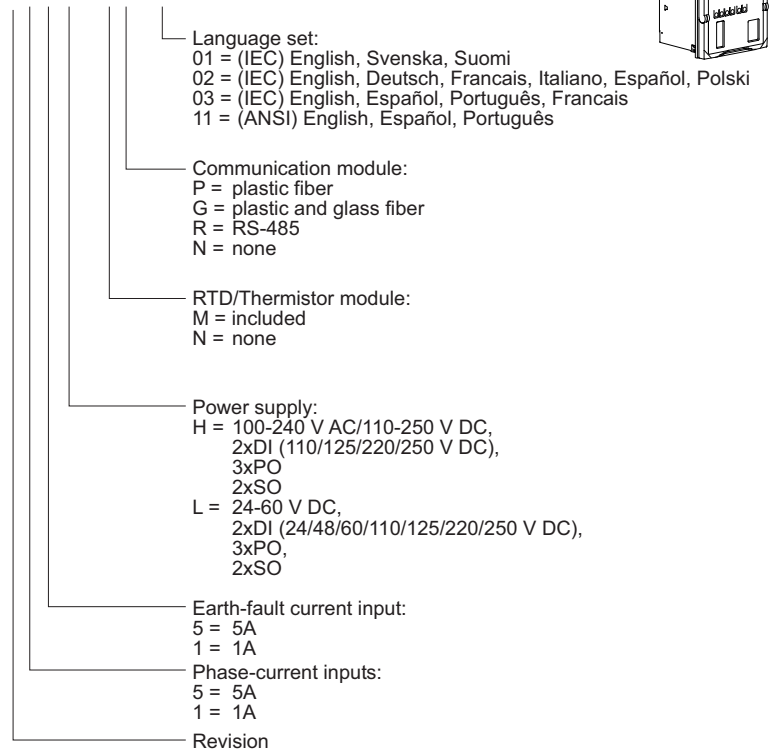

A051552_3

Fig. 7.-1 Ordering key for complete relays

Use the ordering key information in Fig. 7.-2 to generate the order number when ordering spare units.

Technical Reference Manual - ANSI Version

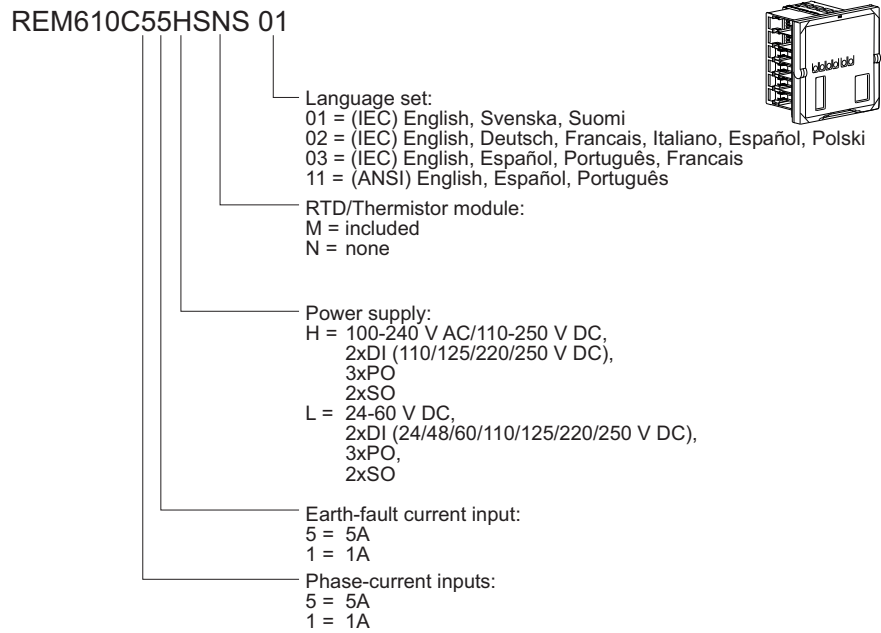

A051553_3

Fig. 7.-2 Ordering key for spare units

The following accessories are available:

Item	Order number
Semi-flush mounting kit	1MRS050696
Inclined (/ 25°) semi-flush mounting kit	1MRS050831
Wall mounting kit	1MRS050697
19" Rack mounting kit, two relays side-by-side	1MRS050695
19" Rack mounting kit, single relay	1MRS050694
19" Rack mounting kit, single relay and RTXP18 (REM610)	1MRS090938
19" equipment frame mounting kit (Combiflex), single relay and RTXP18 (REM610)	1MRS090924
19" equipment frame mounting kit (Combiflex), single relay	1MRS050779
Front communication cable	1MRS050698
Communication modules:	
• Plastic fibre	1MRS050889
• RS-485	1MRS050892
• Plastic and glass fibre	1MRS050891

8.

Check lists

Table 8.-1 Setting group 1

Variable	Group/ Channel 1 (R, W, P)	Setting range	Default setting	Customer's setting
Safe stall time	1S1	2...120 s	2 s	
Weighting factor	1S2	20...100%	50 %	
Time constant dial	1S3	1...64	1	
Prior alarm level	1S4	50...100%	95 %	
Restart disable level	1S5	20...80%	40 %	
Ambient temperature	1S6	0...70°C	40°C	
Start-up current for motor or pickup value of element 48/14	1S7	1.00...10.0 x FLA	1.00 x FLA	
Start-up time for motor or operate time of element 48/14	1S8	0.30...80.0 s	0.30 s	
Pickup value of element 50P	1S9	0.50...20.0 x FLA	1.00 x FLA	
Operate time of element 50P	1S10	0.05...30.0 s	0.05 s	
Pickup value of element 51N	1S11	1.0...100% I _n CT	1.0% I _n CT	
Operate time of element 51N	1S12	0.05...300 s	0.05 s	
Pickup value of element 37	1S13	30...80% FLA	50% FLA	
Operate time of element 37	1S14	2...600 s	2 s	
Pickup value of element 46	1S15	0.10...0.50 x FLA	0.20 x FLA	
Time constant of element 46 at IDMT characteristic	1S16	5...100	5	
Restart disable value	1S17	5...500 s	5 s	
Countdown rate of start-up time counter	1S18	2...250 s/h	2 s/h	
Operate time of CBFail	1S19	0.10...60.0 s	0.10 s	
Alarm value RTD1A	1S20	0...200°C	0°C	
Operate time RTD1A TDLY	1S26	1...100 s	1 s	
Trip value RTD1T	1S32	0...200°C	0°C	
Operate time RTD1T TDLY	1S38	1...100 s	1 s	
Alarm value RTD2A	1S21	0...200°C	0°C	
Operate time RTD2A TDLY	1S27	1...100 s	1 s	
Trip value RTD2T	1S33	0...200°C	0°C	
Operate time RTD2T TDLY	1S39	1...100 s	1 s	
Alarm value RTD3A	1S22	0...200°C	0°C	
Operate time RTD3A TDLY	1S28	1...100 s	1 s	
Trip value RTD3T	1S34	0...200°C	0°C	
Operate time RTD3T TDLY	1S40	1...100 s	1 s	
Alarm value RTD4A	1S23	0...200°C	0°C	
Operate time RTD4A TDLY	1S29	1...100 s	1 s	
Trip value RTD4T	1S35	0...200°C	0°C	
Operate time RTD4T TDLY	1S41	1...100 s	1 s	
Alarm value RTD5A	1S24	0...200°C	0°C	

Variable	Group/ Channel 1 (R, W, P)	Setting range	Default setting	Customer's setting
Operate time RTD5A TDLY	1S30	1...100 s	1 s	
Trip value RTD5T	1S36	0...200°C	0°C	
Operate time RTD5T TDLY	1S42	1...100 s	1 s	
Alarm value RTD6A	1S25	0...200°C	0°C	
Operate time RTD6A TDLY	1S31	1...100 s	1 s	
Trip value RTD6T	1S37	0...200°C	0°C	
Operate time RTD6T TDLY	1S43	1...100 s	1 s	
Trip value PTC1	1S44	0.1...15.0 kΩ	0.1 kΩ	
Trip value PTC2	1S45	0.1...15.0 kΩ	0.1 kΩ	
Checksum, SGF 1	1S61	0...255	0	
Checksum, SGF 2	1S62	0...255	0	
Checksum, SGF 3	1S63	0...255	2	
Checksum, SGF 4	1S64	0...7	0	
Checksum, SGF 5	1S65	0...255	0	
Checksum, SGB 1	1S71	0...16383	0	
Checksum, SGB 2	1S72	0...16383	0	
Checksum, SGB 3	1S73	0...16383	0	
Checksum, SGB 4	1S74	0...16383	0	
Checksum, SGB 5	1S75	0...16383	0	
Checksum, SGR 1	1S81	0...524287	6826	
Checksum, SGR 2	1S82	0...524287	6826	
Checksum, SGR 3	1S83	0...524287	0	
Checksum, SGR 4	1S84	0...524287	9557	
Checksum, SGR 5	1S85	0...524287	9557	
Checksum, SGL 1	1S91	0...4194303	4	
Checksum, SGL 2	1S92	0...4194303	8	
Checksum, SGL 3	1S93	0...4194303	0	
Checksum, SGL 4	1S94	0...4194303	0	
Checksum, SGL 5	1S95	0...4194303	0	
Checksum, SGL 6	1S96	0...4194303	0	
Checksum, SGL 7	1S97	0...4194303	0	
Checksum, SGL 8	1S98	0...4194303	0	

Table 8.-2 Setting group 2

Variable	Group/ Channel 2 (R, W, P)	Setting range	Default setting	Customer's setting
Safe stall time	2S1	2...120 s	2 s	
Weighting factor	2S2	20...100%	50 %	
Time constant dial	2S3	1...64	1	
Prior alarm level	2S4	50...100%	95 %	
Restart disable level	2S5	20...80%	40 %	
Ambient temperature	2S6	0...70°C	40°C	

Variable	Group/ Channel 2 (R, W, P)	Setting range	Default setting	Customer's setting
Start-up current for motor or start value of element 48/14	2S7	1.00...10.0 x FLA	1.00 x FLA	
Start-up time for motor or operate time of element 48/14	2S8	0.30...80.0 s	0.30 s	
Pickup value of element 50P	2S9	0.50...20.0 x FLA	1.00 x FLA	
Operate time of element 50P	2S10	0.05...30.0 s	0.05 s	
Pickup value of element 51N	2S11	1.0...100% I _n CT	1.0% I _n CT	
Operate time of element 51N	2S12	0.05...300 s	0.05 s	
Pickup value of element 51P	2S13	30...80% FLA	50% FLA	
Operate time of element 51P	2S14	2...600 s	2 s	
Pickup value of element 46	2S15	0.10...0.50 x FLA	0.20 x FLA	
Time constant of element 46 at IDMT characteristic	2S16	5...100	5	
Restart disable value	2S17	5...500 s	5 s	
Countdown rate of start-up time counter	2S18	2...250 s/h	2 s/h	
Operate time of CBFail	2S19	0.10...60.0 s	0.10 s	
Alarm value RTD1A	2S20	0...200°C	0°C	
Operate time RTD1A TDLY	2S26	1...100 s	1 s	
Trip value RTD1T	2S32	0...200°C	0°C	
Operate time RTD1T TDLY	2S38	1...100 s	1 s	
Alarm value RTD2A	2S21	0...200°C	0°C	
Operate time RTD2A TDLY	2S27	1...100 s	1 s	
Trip value RTD2T	2S33	0...200°C	0°C	
Operate time RTD2T TDLY	2S39	1...100 s	1 s	
Alarm value RTD3A	2S22	0...200°C	0°C	
Operate time RTD3A TDLY	2S28	1...100 s	1 s	
Trip value RTD3T	2S34	0...200°C	0°C	
Operate time RTD3T TDLY	2S40	1...100 s	1 s	
Alarm value RTD4A	2S23	0...200°C	0°C	
Operate time RTD4A TDLY	2S29	1...100 s	1 s	
Trip value RTD4T	2S35	0...200°C	0°C	
Operate time RTD4T TDLY	2S41	1...100 s	1 s	
Alarm value RTD5A	2S24	0...200°C	0°C	
Operate time RTD5A TDLY	2S30	1...100 s	1 s	
Trip value RTD5T	2S36	0...200°C	0°C	
Operate time RTD5T TDLY	2S42	1...100 s	1 s	
Alarm value RTD6A	2S25	0...200°C	0°C	
Operate time RTD6A TDLY	2S31	1...100 s	1 s	
Trip value RTD6T	2S37	0...200°C	0°C	
Operate time RTD6T TDLY	2S43	1...100 s	1 s	
Trip value PTC1	2S44	0.1...15.0 kΩ	0.1 kΩ	

Variable	Group/ Channel 2 (R, W, P)	Setting range	Default setting	Customer's setting
Trip value PTC2	2S45	0.1...15.0 kΩ	0.1 kΩ	
Checksum, SGF 1	2S61	0...255	0	
Checksum, SGF 2	2S62	0...255	0	
Checksum, SGF 3	2S63	0...255	2	
Checksum, SGF 4	2S64	0...7	0	
Checksum, SGF 5	2S65	0...255	0	
Checksum, SGB 1	2S71	0...16383	0	
Checksum, SGB 2	2S72	0...16383	0	
Checksum, SGB 3	2S73	0...16383	0	
Checksum, SGB 4	2S74	0...16383	0	
Checksum, SGB 5	2S75	0...16383	0	
Checksum, SGR 1	2S81	0...524287	6826	
Checksum, SGR 2	2S82	0...524287	6826	
Checksum, SGR 3	2S83	0...524287	0	
Checksum, SGR 4	2S84	0...524287	9557	
Checksum, SGR 5	2S85	0...524287	9557	
Checksum, SGL 1	2S91	0...4194303	4	
Checksum, SGL 2	2S92	0...4194303	8	
Checksum, SGL 3	2S93	0...4194303	0	
Checksum, SGL 4	2S94	0...4194303	0	
Checksum, SGL 5	2S95	0...4194303	0	
Checksum, SGL 6	2S96	0...4194303	0	
Checksum, SGL 7	2S97	0...4194303	0	
Checksum, SGL 8	2S98	0...4194303	0	

Table 8.-3 Control parameters

Description	Parameter (channel 0)	Setting range	Default setting	Customer's setting
FLA secondary (protected unit scaling factor)	V103	0.50...2.50	1.00	
Rated frequency	V104	50 or 60 Hz	60 Hz	
Time setting range for demand values in minutes	V105	0...999 min	10 min	
Non-volatile memory settings	V106	0...63	63	
Time setting for disabling new trip targets on the LCD	V108	0...999 min	60 min	
Trip-circuit supervision	V113	0 = not in use 1 = in use		

Description	Parameter (channel 0)	Setting range	Default setting	Customer's setting
Sensor/thermistor selection for input RTD1	V121	0 = not in use 1 = Pt100 -45...+150°C 2 = Pt250 -45...+150°C 3 = Pt1000 -45...+150°C 4 = Ni100 -45...+250°C 5 = Ni120 -45...+250°C 6 = Cu10 -45...+150°C 7 = Ni120US -45...+250°C 8 = PTC 0...20 kΩ	0	
Sensor selection for input RTD2	V122	0 = not in use 1 = Pt100 -45...+150°C 2 = Pt250 -45...+150°C 3 = Pt1000 -45...+150°C 4 = Ni100 -45...+250°C 5 = Ni120 -45...+250°C 6 = Cu10 -45...+150°C 7 = Ni120US -45...+250°C	0	
Sensor selection for input RTD3	V123	0 = not in use 1 = Pt100 -45...+150°C 2 = Pt250 -45...+150°C 3 = Pt1000 -45...+150°C 4 = Ni100 -45...+250°C 5 = Ni120 -45...+250°C 6 = Cu10 -45...+150°C 7 = Ni120US -45...+250°C	0	

Technical Reference Manual - ANSI Version

Description	Parameter (channel 0)	Setting range	Default setting	Customer's setting
Sensor/thermistor selection for input RTD4	V124	0 = not in use 1 = Pt100 -45...+150°C 2 = Pt250 -45...+150°C 3 = Pt1000 -45...+150°C 4 = Ni100 -45...+250°C 5 = Ni120 -45...+250°C 6 = Cu10 -45...+150°C 7 = Ni120US -45...+250°C 8 = PTC 0...20 kΩ	0	
Sensor selection for input RTD5	V125	0 = not in use 1 = Pt100 -45...+150°C 2 = Pt250 -45...+150°C 3 = Pt1000 -45...+150°C 4 = Ni100 -45...+250°C 5 = Ni120 -45...+250°C 6 = Cu10 -45...+150°C 7 = Ni120US -45...+250°C	0	
Sensor selection for input RTD6	V126	0 = not in use 1 = Pt100 -45...+150°C 2 = Pt250 -45...+150°C 3 = Pt1000 -45...+150°C 4 = Ni100 -45...+250°C 5 = Ni120 -45...+250°C 6 = Cu10 -45...+150°C 7 = Ni120US -45...+250°C		
Remote control of settings	V150	0 = setting group 1 1 = setting group 2	0	
Unit address of the relay	V200	1...254	1	
Data transfer rate (SPA), kbps	V201	9.6/4.8	9.6	

Description	Parameter (channel 0)	Setting range	Default setting	Customer's setting
Rear communication protocol	V203	0 = SPA 1 = IEC_103 2 = Modbus RTU 3 = Modbus ASCII	0	
Connection type	V204	0 = loop 1 = star	0	
Line-idle state	V205	0 = light off 1 = light on	0	
Optional communication module	V206	0 = not in use 1 = in use	0	

Table 8-4 Parameters for the disturbance recorder

Description	Parameter (channel 0)	Setting range	Default setting	Customer's setting
Sampling rate	M15	800/960 Hz 400/480 Hz 50/60 Hz	800 Hz	
Station identification/unit number	M18	0...9999	0	
Name of the motor drive	M20	Max 16 characters	- ABB -	
Analog channel conversion factor and unit for I_a , I_b and I_c	M80, M81, M82	Factor 0...65535, unit (A, kA), e.g. 10, kA	00001,CT	
Analog channel conversion factor and unit for the ground-fault current	M83	Factor 0...65535, unit (A, kA), e.g. 10, kA	00001,CT	
Internal trigger signals' checksum	V236	0...8191	2728	
Internal trigger signal's edge	V237	0...8191	0	
Checksum of internal signal storing mask	V238	0...8191	6842	
Post-triggering recording length	V240	0...100%	50 %	
External trigger signal's checksum	V241	0...31	0	
External trigger signal's edge	V242	0...31	0	
Checksum of external signal storing mask	V243	0...31	0	

9. Abbreviations

Abbreviation	Description
ANSI	American National Standards Institute
ASCII	American Standard Code for Information Interchange
AWG	American wire gauge
CBFAIL	Circuit-breaker failure protection
CBFP	Circuit-breaker failure protection
CD	Change detect; compact disk
CPU	Central processing unit
CRC	Cyclical redundancy check
CT	Current transformer
DI	Digital input
EEPROM	Electrically Erasable Programmable Read-Only Memory
EMC	Electromagnetic compatibility
ER	Event records
FR	Fault record
GI	General interrogation
HMI	Human-machine interface
HR	Holding register
IDMT	Inverse definite minimum time characteristic
IEC	International Electrotechnical Commission
IEC_103	Standard IEC 60870-5-103
IED	Intelligent electronic device
IEEE	Institute of Electrical and Electronics Engineers, Inc.
IR	Input register
IRF	Internal relay fault
LCD	Liquid crystal display
LED	Light-emitting diode
LRC	Longitudinal redundancy check
MP	Minute-pulse
MSB	Most significant bit
MV	Medium voltage
NACK	Negative acknowledgments
NC	Normally closed
NO	Normally open
NPS	Negative-phase-sequence
PC	Personal computer
PCB	Printed circuit board
PLC	Programmable logical controller
PO	Power output, process object
PTC	Positive temperature coefficient
REV	Phase reversal

Technical Reference Manual - ANSI Version

RMS	Root mean square
RTD	Resistance temperature device
RTU	Remote terminal unit
SGB	Switchgroup for digital inputs
SGF	Switchgroup for functions
SGL	Switchgroup for LEDs
SGR	Switchgroup for output contacts
SO	Signal output
SP	Second-pulse
SPA	Data communication protocol developed by ABB
TCR	Temperature coefficient of resistance
TCS	Trip-circuit supervision
UDR	User-defined register



ABB Oy
Distribution Automation
P.O. Box 699
FI-65101 Vaasa
FINLAND
+358 10 2211
+358 10 224 1080
www.abb.com/substationautomation