

## INSTRUCTIONS

### Ground Fault Monitor

---

- TYPE TMC      Monitor without Sensor Test Feature
- TYPE TMS      Monitor with Sensor Test Feature

For Use with Type GRC Ground Relay



TABLE OF CONTENTS

Introduction . . . . . Page 2  
Precautions . . . . . Page 2  
Placing Monitor into Service . . . . . Page 3  
Application Data . . . . . Page 4  
Operation . . . . . Page 6  
Testing . . . . . Page 11

INTRODUCTION

These instructions contain the information required to properly install, operate, and test the Ground-Shield ground fault test and monitor panel, Types TMC and TMS semi-flush and surface mounted.

The TMC and TMS monitors are optional accessories for use with the Type GRC surface case ground fault relays to provide operation indicators and testing features.

Standard features include:

- a. Flush mounting case.
- b. Memory type operation target.
- c. Lamp, to indicate availability of control power.
- d. Relay testing with or without tripping of disconnect means.
- e. Sensor testing with or without tripping of disconnect means (Type TMS only).

Optional features:

- a. Auxiliary contact output for tripping or alarm, or to prevent reclosing of circuit breakers.

See Instruction Book IB 7.1.1.7-5 for information covering the Type GRC ground relay and Type GS ground sensors. The Type TMS monitor can be used only with those ground sensors that include a test winding (Terminal "T").

Earlier versions of the TMC Monitor, catalog number 202T3010 and 202T3214 (120VAC/125VDC dual-rating) have slightly different connections than the units shown in this instruction book. See "MAINTENANCE" on Page 11 or refer to IB 7.1.1.7-6.

See Instruction Book IB 7.1.1.7-9 for recommendations for Field Testing of Ground Fault Systems.

PRECAUTIONS

The following precautions should be taken when applying this equipment:

- 1. Incorrect wiring may result in damage. Be sure wiring agrees with the connection diagram for the particular unit before the unit is energized.
- 2. Do not apply high voltage tests to solid-state relays or monitors. If a control wiring insulation test is required, bond all terminals together before applying test voltage.
- 3. Follow test instructions to verify that unit is in proper working order. If a monitor is found to be defective, we suggest that it be returned to the factory for repair. Immediate replacement can be made available from the factory; identify by catalog number. We suggest that a complete spare unit be ordered as a replacement, and the inoperative unit be repaired and retained as a spare. CAUTION: Since troubleshooting entails working with energized equipment, caution should be taken to avoid personal shock. Only competent technicians familiar with good safety practices should service these devices.
- 4. Do not hold the TEST SWITCH in the test position for more than 2 seconds.

## PLACING THE MONITOR INTO SERVICE

1. RECEIVING, HANDLING, STORAGE

Upon receipt of the unit (when not included as part of a switchboard) examine for shipping damage. If damage or loss is evident, file a claim at once and promptly notify the nearest BBC Brown Boveri Inc. Sales Office. Use normal care in handling to avoid mechanical damage. Keep reasonably clean and dry. The ground fault monitor is normally shipped with the operation indicator (target) display showing orange.

2. INSTALLATION

## Mounting

The panel drilling and cutout information is given in Figure 1. A rectangular panel cutout and (4) mounting holes are required. The outline of the Type TMC is shown in Figure 2A, and the Type TMS is shown in Figure 2B.

The monitor is completely enclosed. The upper part of the front plate provides space for user's identification markings of associated circuits or disconnect means. If stenciling is desired, remove the switch guards and (4) screws (3 inches apart) to detach the front plate.

## Connections

Use only copper wire when making connections. Special care must be taken to connect control power of proper voltage and polarity. See monitor nameplate for voltage rating.

Typical external connection diagrams of TMC and TMS monitors and GRC relays are shown in Figures 3-6. All monitor leads connected to the ground fault relay should be routed together.

See Application Data section for control and test power requirements.

NOTE: Remove the jumper between relay terminals 4 and 5 of the GRC relay when the monitor is wired in.

IF THE MONITOR IS DISCONNECTED OR REMOVED FROM THE CIRCUIT FOR ANY REASON, YOU MUST REINSTALL A JUMPER BETWEEN TERMINALS 4 AND 5 ON THE GRC RELAY (JUMPER COMPLETES TRIPPING CIRCUIT).

3. CONTROLS AND INDICATORS

The Type TMC or TMS monitor does not contain adjustments which require field settings. The following controls and indicators are provided:

CONTROL POWER LIGHT - Indicates presence of control power.

NO-TRIP SWITCH - Holding the spring-return toggle in the up position temporarily disconnects the trip coil (and auxiliary output relay if provided).

TEST SWITCH - For Type TMC, tests relay with or without tripping of circuit breaker. For Type TMS, tests sensor and relay with or without tripping circuit breaker.

GROUND FAULT TARGET - Orange target indicates relay operation under ground fault or test conditions. Indication is retained even if control power is lost after operation.

RESET PUSHBUTTON - Resets target to black (and resets auxiliary output relay if provided).

4. INITIAL CHECK

After wiring is completed and checked, apply control power and note if lamp is lit. Then attempt to reset the operation indicator. If the indicator cannot be reset, recheck connections, voltage and polarity. Do not attempt any other tests until wiring errors are corrected.

APPLICATION DATA

The Types TMC or TMS Test and Monitor Panel is an optional, flush mounted unit for use with the standard GRC Ground Fault Relay System. Standard Features include: 1) A CONTROL POWER LAMP to indicate the presence of control power to the relay system. 2) A ground fault OPERATION INDICATOR which maintains indication even on loss of control power. 3) A TEST SWITCH for performing an operational test on the GRC ground relay. 4) A NO-TRIP switch to prevent the disconnect from tripping when the operational test is performed, if continuity of service must be maintained. 5) A RESET pushbutton to reset the target from orange to black.

An auxiliary output relay can be provided as an option for remote alarm or other purposes. Its contacts are reset after a relay operation by the RESET pushbutton.

TYPE TMC MONITOR

This monitor allows testing of the GRC relay and the disconnect device operation. Any of the Type GS Ground Sensors may be used in this system. If the sensor includes the "T" terminal, it must be jumpered to the S1 terminal.

TYPE TMS MONITOR

The Type TMS monitor is provided with test circuits and current limiting resistors to inject a test current into the sensor test winding (3-5 amperes maximum). Thus the test power transformer should be sized accordingly to supply the test current at 120VAC for 1-2 seconds. A minimum rating of 250VA is recommended. Note that the monitor test and control circuits are isolated, hence could be connected to different sources. However, the monitor terminal 2 should be connected to the ungrounded end of the 120VAC test source, and terminal S2 of the sensor must be wired to the grounded terminal of the same source. Also, the optional trip or alarm contacts are isolated and could be connected to another circuit.

The Type TMS monitor is designed for use with Type GS sensors that have provisions for testing (terminal T). The test circuit requires that the T-S1 jumper supplied on the sensor be removed. See the GRC relay instruction book IB 7.1.1.7-5 for a list of available sensors.

CONTROL SOURCE CONNECTIONS

The primary of a control transformer, if provided and supplied from the power circuit, must be connected line to line.

When control power is taken from the power circuit ahead of the main disconnecting means or from a separate source, the control circuit conductors should have overcurrent protection. Control circuit overcurrent protective devices should have an interrupting rating adequate for the short-circuit current available. Conductors ahead of the control circuit overcurrent protection should be kept as short as possible.

RATINGS

Major ratings appear on the front panel or labels.

Main Control Voltage: See nameplate for nominal control voltage.

Available control voltage models: 120VAC  
125VDC  
48VDC  
24/32VDC

Monitor must have the same control voltage rating as the associated GRC relay.

Maximum voltage is nominal plus 10%.

Minimum operating control voltage: 55% of nominal for AC monitors.  
80% of nominal for DC monitors.

Control Source Drain: Negligible on stand-by; 15-50 ma on operation of auxiliary relay.

Output Contacts at 125VDC:

30 amps RMS for 0.33 seconds	5 amps RMS continuous
12.5 amps RMS for 0.25 seconds	1 amp break (resistive)
7.5 amps RMS for 1 second	0.3 amp break (inductive)

**SENSOR TEST SOURCE** (Type TMS Only): 120VAC (+10, -20%)

Sensor Test Drain: The test current provided by the TMS Monitor must be related to the pick-up current range of the GRC Ground Relay used in the application. Resistors in the monitor are sized to provide sufficient current to operate the particular GRC Relay for all pickup settings. See Table 1 for a listing of TMS Monitors. Table 1 also indicates the range of current drain to be expected for each model. The control transformer must provide this current. The actual value of current drawn will depend on the particular sensor being used in the system and the line voltage.

TABLE 1: SUMMARY OF COMMON UNITS

Monitor Type	For Use With GRC Range	Sensor Test Drain	Auxiliary Contact	Monitor Catalog Number
TMC	All	--	No	202T30x0
			Yes	202T30x4
TMS	2 - 24A	0.1 - 0.2A	No	202T58x0
			Yes	202T58x4
	5 - 60A	0.2 - 0.4A	No	202T57x0
			Yes	202T57x4
	20 - 240A	0.7 - 1A	No	202T56x0
			Yes	202T56x4
	100 - 1200A	3 - 5A	No	202T55x0
			Yes	202T55x4

IMPORTANT: The "x" in the above catalog numbers MUST be replaced with the proper digit indicating the main control voltage value to completely specify the unit. These are:

- "6" for 120VAC
- "4" for 125VDC
- "3" for 48VDC
- "0" for 24/32VDC

For the Type TMS, the sensor test voltage source is always 120VAC. Test current drain shown exists only during operation of the Sensor Test (should be 1 - 2 seconds in duration).

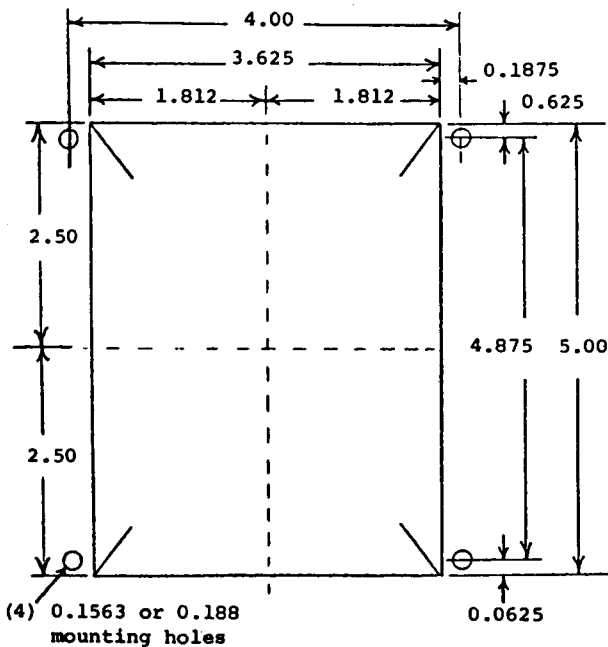

Fig. 1: Panel Cutout for FLUSH MOUNTED MONITOR (dimensions in inches)

OPERATION

The CONTROL POWER light should normally be lit, indicating the availability of control power. If it is off, control power fuses or wiring should be checked. If the control power transformer is on the load side of the circuit protective device, the light will not be on until the disconnect is closed. Should the light be burned out it is easily replaced.

Upon a ground fault or a test operation, the FAULT indicator will change state to orange, and the optional auxiliary contact (if provided) will pick up and seal in.

The GRC Ground Fault Relay's thyristor (SCR) output is restored to functional status upon the opening of the circuit protective device auxiliary contact (52a) and does not require manual reset.

The FAULT target is a memory type and will retain its indication even if the control power transformer is on the load side of the disconnect, thus resulting in loss of control power upon operation. The RESET pushbutton resets the target and the auxiliary contact (if provided).

Reclosing on a fault may increase arcing damage; therefore, it is recommended that a ground fault condition be located and corrected before the disconnect is reclosed.

The types TMC and TMS Monitors allow GRC Relay testing with or without tripping the circuit disconnect device. For the Type TMS, actuation of the TEST switch disconnects one of several sensor windings from a parallel arrangement and connects it to a 120VAC source through resistors which set the test current level. The test sequence, which is also printed on the front panel of the monitor, is:

FOR "TRIP TEST"

1. Operate TEST switch UP for 1-2 seconds maximum, RELEASE.
2. Press target RESET button.

FOR "NO-TRIP TEST"

1. Operate NO-TRIP switch UP and HOLD.
2. Operate TEST switch UP for 1-2 seconds maximum. RELEASE.
3. RELEASE NO-TRIP switch.
4. Press RESET button.

CAUTION: Do not hold the TEST switch on for more than 2 seconds. If the relay or monitor operation is improper, recheck wiring, voltages, and interconnected devices before resuming tests.

NOTE: Control power must be present to reset the target.

DOUBLE ENDED APPLICATIONS

To verify the operation of the GRC Relay's "No-Trip" Interlock used on the main breakers in double-ended applications, the following procedure may be used: close the interlocking device or the tie circuit breaker, or temporarily short circuit GRC Relay terminals 9 and 10. Perform the TRIP TEST. The relay should NOT trip.

If terminals 9 and 10 were shorted to run the test, BE SURE to remove the short at the end of the tests.

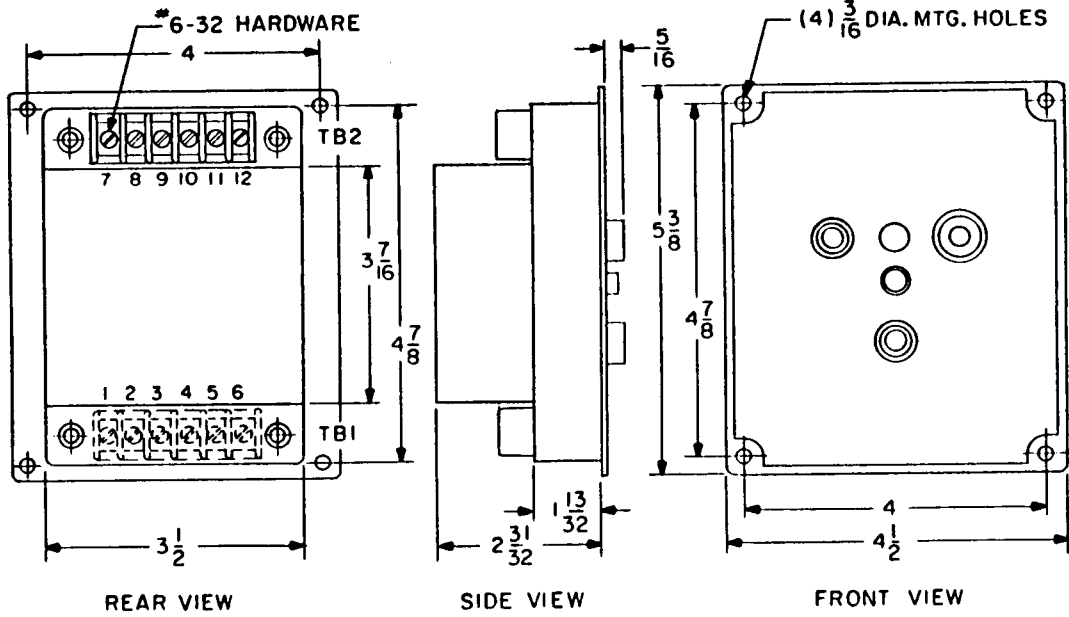

FIGURE 2A: TMC MONITOR OUTLINE

All Dimensions  
In Inches

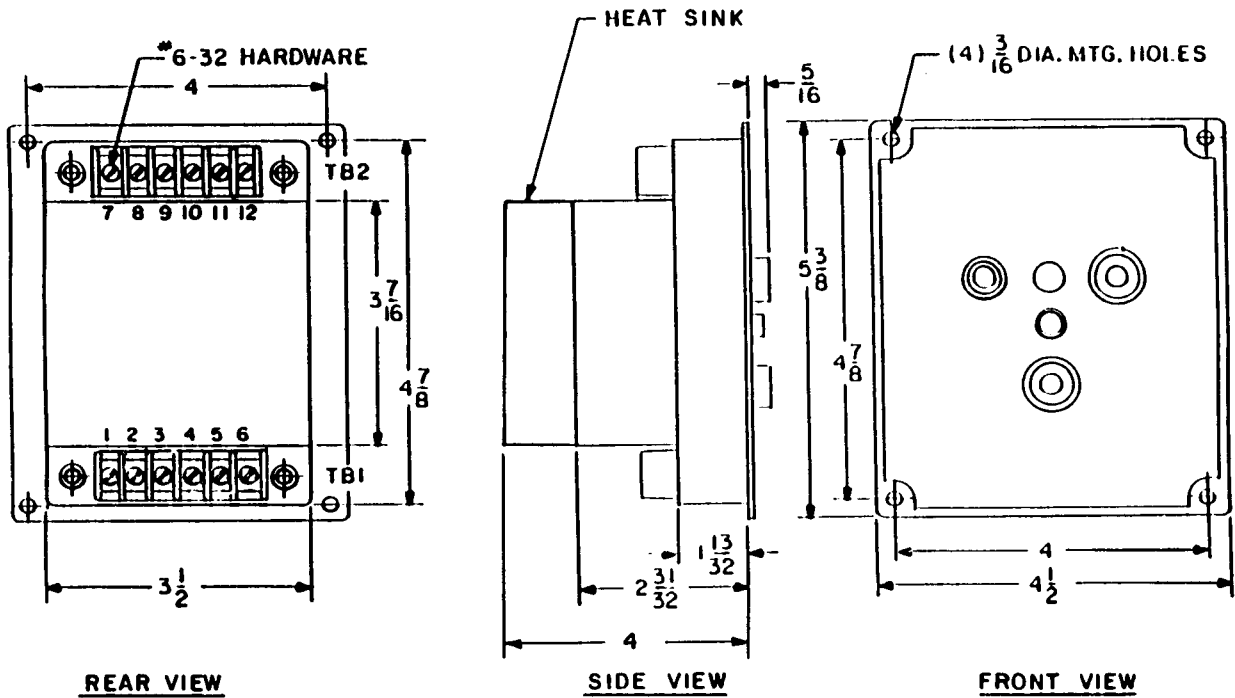

FIGURE 2B: TMS MONITOR OUTLINE





GRC RELAY - TMS MONITOR INTERCONNECTION DIAGRAMS

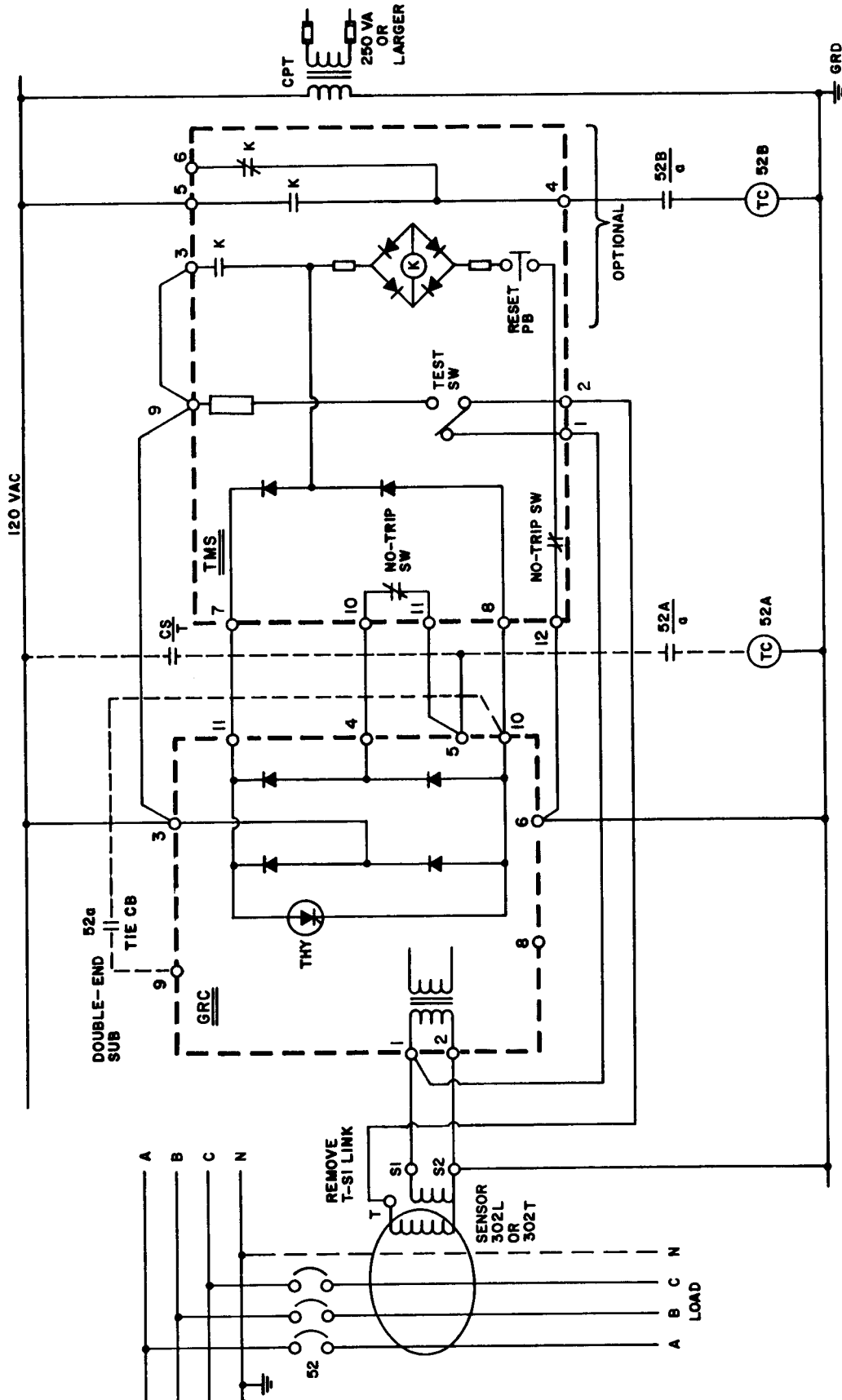

FIGURE 5: GRC/TMS WITH 120VAC CONTROL AND 120VAC TEST POWER

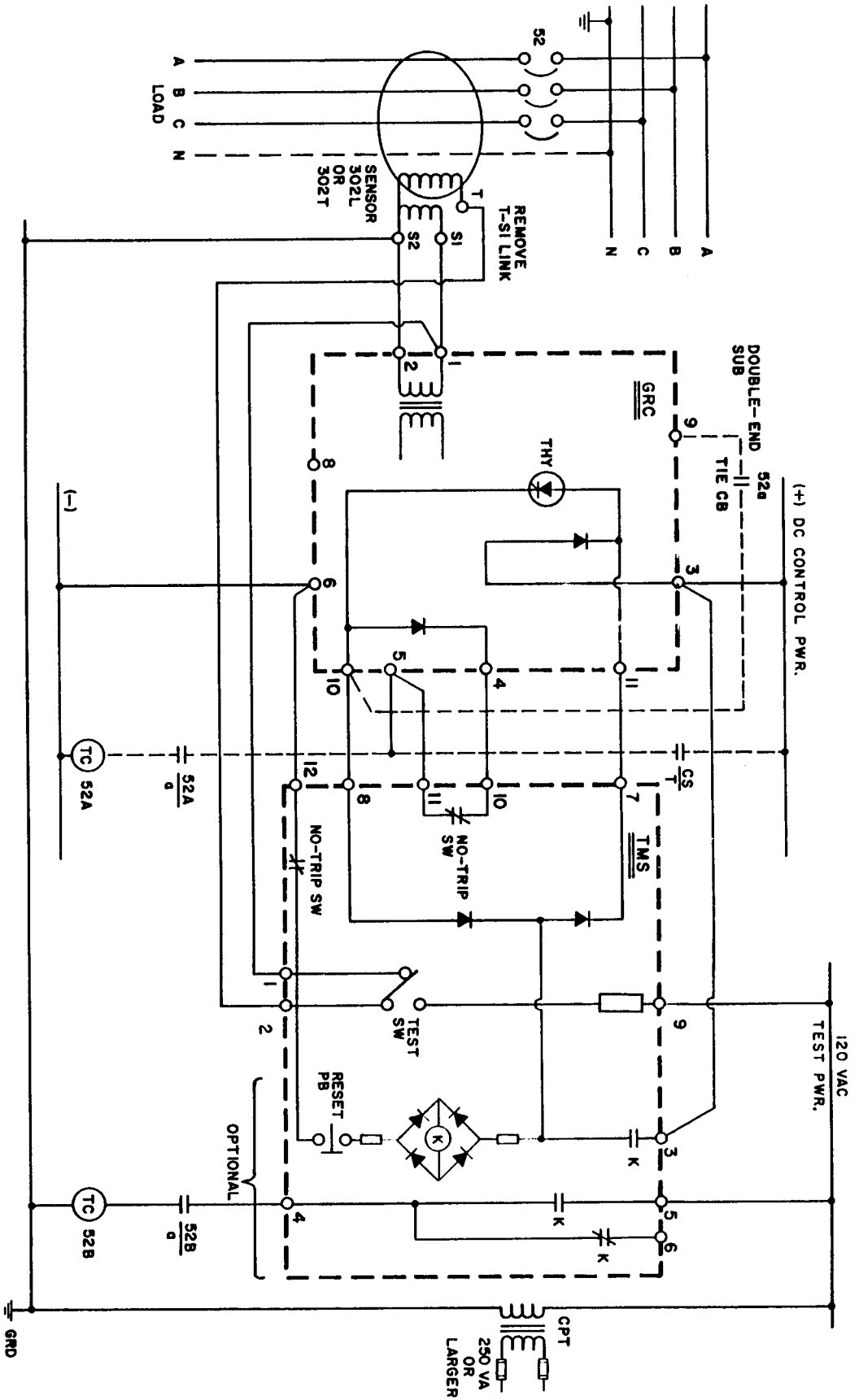

FIGURE 6: GRC/TMS WITH DC CONTROL POWER AND 120VAC TEST POWER

## TESTING

1. MAINTENANCE AND RENEWAL PARTS

No routine maintenance is required on the monitor. Follow test instructions to verify that the unit is in proper working order. We recommend that an inoperative unit be returned to the factory for repair.

The control power indicating lamp is a plug-in device. Replacement lamps may be ordered from the factory. The pins on the lamp must be properly aligned when reinstalling in the socket.

Note: If you are replacing an earlier, dual-rated (120VAC/125VDC) version of the TMC Monitor (Catalog #202T3010 or 202T3214) with the present design TMC covered by this instruction book, all connections are the same EXCEPT the wire on terminal 9 of the older unit moves to terminal 2 of the new unit.

2. HIGH POTENTIAL TESTS

Do not apply high voltage tests to solid-state circuits. If a control wiring insulation test is required, bond all terminals together before applying test voltage.

3. TESTING

Periodic testing is recommended to confirm proper system operation.

Operational Tests

Refer to "OPERATION" section, Page 6. Tests can be performed with the circuit breaker in open position, providing control and test power is available. Also see IB 7.1.1.7-9 for additional recommendations on Field Testing of Ground Fault Systems.

Bench Tests (with Type GRC Relay)

If bench tests are desired, we recommend that the monitor be tested with a type GRC surface case relay interconnected as shown in Figure 3 to 6, as appropriate. Follow the instructions in the "OPERATION" section, Page 6.

To apply current signals to the GRC relay use the test circuits shown in Instruction Book IB 7.1.1.7-5, including a type GS sensor.

Bench Tests (without Type GRC Relay)

If a relay is not available and a target or auxiliary relay operation test is necessary, connect the monitor to an appropriate control power source as shown in Figure 7.

Operate and hold the TEST switch, then depress the external test pushbutton momentarily to short circuit terminal 7 to terminal 8. Target shall operate and auxiliary relay (if provided) will pick up. Release TEST switch and operate RESET button, if repeating tests.

Continuity of test circuits in monitors can be checked by means of an ohmmeter across terminals 2 and 9 (Type TMS) or 8 and 2 (Type TMC). Operate the TEST switch to take a reading.

Leave the target in the orange position after finishing bench tests and prior to installation in switchboard. Refer to "INITIAL CHECK" section, Page 3.

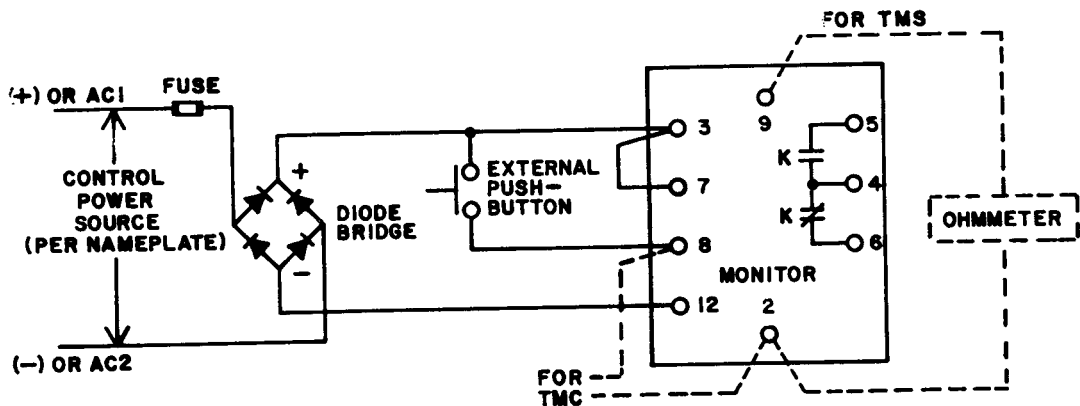

FIGURE 7: BENCH TEST WIRING FOR CHECKING MONITOR WITHOUT GRC RELAY