

Product Specification

IRB 640

3HAC 9217-1 / Rev. 1
M2000



S4Cplus



140



2400



1400



840



4400



340



6400S



640



6400PE



6400R

ABB

The information in this document is subject to change without notice and should not be construed as a commitment by ABB Automation Technologies, Robotics. ABB Automation Technologies, Robotics assumes no responsibility for any errors that may appear in this document.

In no event shall ABB Automation Technologies, Robotics be liable for incidental or consequential damages arising from use of this document or of the software and hardware described in this document.

This document and parts thereof must not be reproduced or copied without ABB Automation Technologies, Robotics' written permission, and contents thereof must not be imparted to a third party nor be used for any unauthorized purpose. Contravention will be prosecuted.

Additional copies of this document may be obtained from ABB Automation Technologies, Robotics at its then current charge.

© Copyright 2001 ABB. All rights reserved.

Article number: 3HAC 9217-1/Rev 1
Issue: M2000

ABB Automation Technologies, Robotics
SE-721 68 Västerås
Sweden

CONTENTS

	Page
1 Description	3
1.1 Structure.....	3
1.2 Safety/Standards	5
1.3 Installation	6
Operating requirements.....	7
Mounting the manipulator.....	7
Load diagram	8
Mounting equipment.....	9
1.4 Maintenance and Troubleshooting	11
1.5 Robot Motion.....	12
Velocity	13
Resolution	13
1.6 Signals	13
Signal connections on robot arm.....	13
Customer Power Vacuum (option).....	13
2 Specification of Variants and Options	15
3 Accessories	19
4 Index	21

1 Description

1.1 Structure

IRB 640 is a 4-axis industrial robot, designed specifically for manufacturing industries that use flexible robot-based automation. The robot has an open structure that is specially adapted for flexible use, and can communicate extensively with external systems.

The IRB 640 is extremely powerful with a handling capacity of 160 kg, and thanks to optimised robot drive-trains and ABB's patented QuickMove™ functions, it is the quickest robot in its class.

The robot is equipped with the operating system BaseWare OS. BaseWare OS controls every aspect of the robot, like motion control, development and execution of application programs communication etc. See Product Specification S4Cplus.

For additional functionality, the robot can be equipped with optional software for application support - for example gluing and arc welding, communication features - network communication - and advanced functions such as multitasking, sensor control etc. For a complete description on optional software, see the Product Specification RobotWare Options.

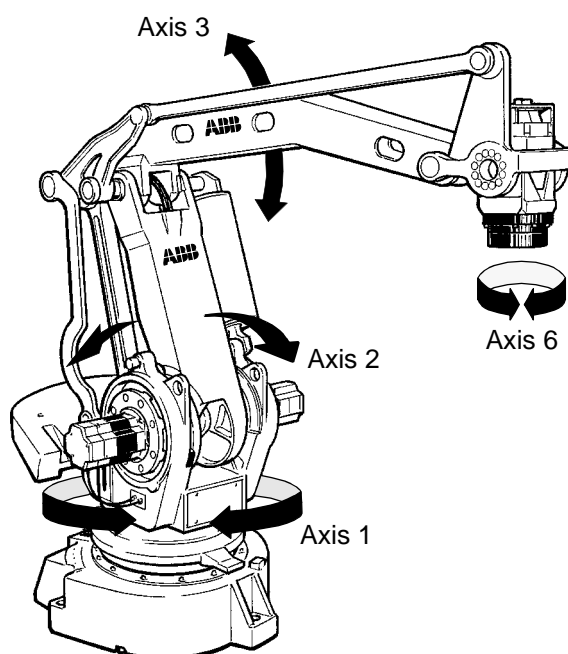

Figure 1 The IRB 640 manipulator has 4 axes.

Manipulator weight 1950 kg

Airborne noise level:

The sound pressure level outside the working space	< 70 dB (A) Leq (acc. to Machinery directive 89/392 EEC)
--	--

Description

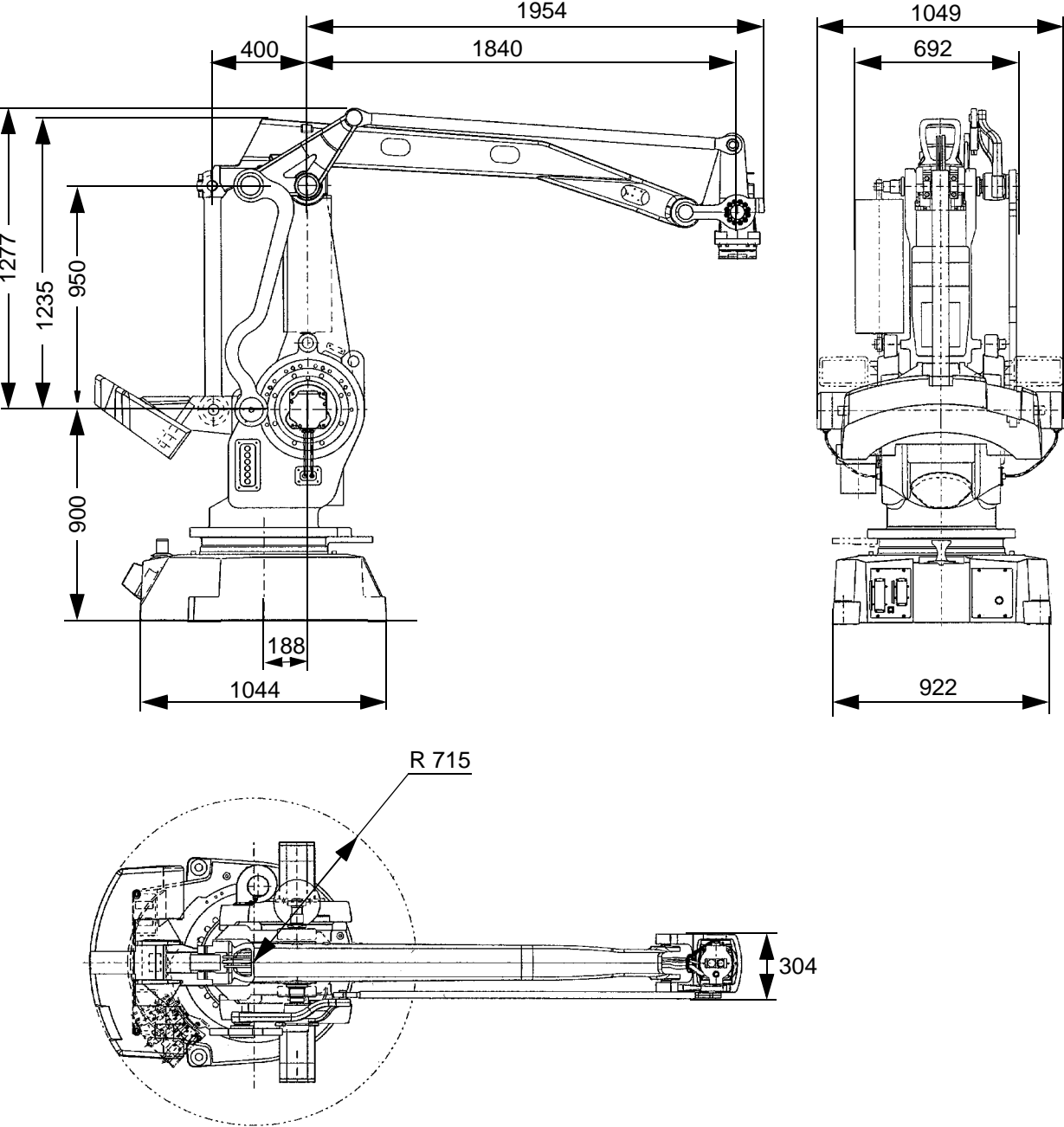

Figure 2 View of the manipulator from the side, rear and above (dimensions in mm).

1.2 Safety/Standards

The robot conforms to the following standards:

EN 292-1	Safety of machinery, terminology
EN 292-2	Safety of machinery, technical specifications
EN 954-1	Safety of machinery, safety related parts of control systems
EN 60204	Electrical equipment of industrial machines
IEC 204-1	Electrical equipment of industrial machines
ISO 10218, EN 775	Manipulating industrial robots, safety
ANSI/RIA 15.06/1999	Industrial robots, safety requirements
ISO 9409-1	Manipulating industrial robots, mechanical interface
ISO 9787	Manipulating industrial robots, coordinate systems and motions
IEC 529	Degrees of protection provided by enclosures
EN 50081-2	EMC, Generic emission
EN 50082-2	EMC, Generic immunity
ANSI/UL 1740-1996 (option)	Safety Standard for Industrial Robots and Robotic Equipment
CAN/CSA Z 434-94 (option) Safety	Industrial Robots and Robot Systems - General Requirements

The robot complies fully with the health and safety standards specified in the EEC's Machinery Directives.

The robot is designed with absolute safety in mind. It has a dedicated safety system based on a two-channel circuit which is monitored continuously. If any component fails, the electrical power supplied to the motors shuts off and the brakes engage.

Safety category 3

Malfunction of a single component, such as a sticking relay, will be detected at the next MOTOR OFF/MOTOR ON operation. MOTOR ON is then prevented and the faulty section is indicated. This complies with category 3 of EN 954-1, Safety of machinery - safety related parts of control systems - Part 1.

Selecting the operating mode

The robot can be operated either manually or automatically. In manual mode, the robot can only be operated via the teach pendant, i.e. not by any external equipment.

Reduced speed

In manual mode, the speed is limited to a maximum of 250 mm/s (600 inch/min.). The speed limitation applies not only to the TCP (Tool Centre point), but to all parts of the robot. It is also possible to monitor the speed of equipment mounted on the robot.

Three position enabling device

The enabling device on the teach pendant must be used to move the robot when in manual mode. The enabling device consists of a switch with three positions, meaning that all robot movements stop when either the enabling device is pushed fully in, or when it is released completely. This makes the robot safer to operate.

Description

Safe manual movement

The robot is moved using a joystick instead of the operator having to look at the teach pendant to find the right key.

Over-speed protection

The speed of the robot is monitored by two independent computers.

Emergency stop

There is one emergency stop push button on the controller and another on the teach pendant. Additional emergency stop buttons can be connected to the robot's safety chain circuit.

Safeguarded space stop

The robot has a number of electrical inputs which can be used to connect external safety equipment, such as safety gates and light curtains. This allows the robot's safety functions to be activated both by peripheral equipment and by the robot itself.

Delayed safeguarded space stop

A delayed stop gives a smooth stop. The robot stops in the same way as at a normal program stop with no deviation from the programmed path. After approx. 1 second the power supplied to the motors shuts off.

Restricting the working space

The movement of each axis can be restricted using software limits. Axes 1-3 can also be restricted by means of mechanical stops (option).

Hold-to-run control

"Hold-to-run" means that you must depress the start button in order to move the robot. When the button is released the robot will stop. The hold-to-run function makes program testing safer.

Fire safety

Both the manipulator and control system comply with UL's (Underwriters Laboratory) tough requirements for fire safety.

Safety lamp (option)

As an option, the robot can be equipped with a safety lamp mounted on the manipulator. This is activated when the motors are in the MOTORS ON state.

1.3 Installation

The IRB 640 is designed for floor mounting. An end effector of max. weight 160 kg, including payload, can be mounted on the mounting flange (axis 6). Load diagram, see Load diagram on page 8.

Extra loads (valve packages) can be mounted on the upper arm. An extra load can also be mounted on the frame of axis 1. Holes for mounting extra equipment see page 9.

The working range of axes 1-3 can be limited by mechanical stops. Position switches can be supplied on axis 1 and axis 2 for position indication of the manipulator.

Operating requirements

Protection standards	IEC529
Manipulator	IP54
Wrist	IP55

Explosive environments

The robot must not be located or operated in an explosive environment.

Ambient temperature

Manipulator during operation	+5°C (41°F) to +45°C (113°F)
Complete robot during transportation and storage, for short periods (not exceeding 24 hours)	-25°C (13°F) to +55°C (131°F) up to +70°C (158°F)

Relative humidity

Complete robot during transportation and storage	Max. 95% at constant temperature
Complete robot during operation	Max. 95% at constant temperature

Mounting the manipulator

Maximum load in relation to the base coordinate system.

	Endurance load in operation	Max. load at emergency stop
Force xy	± 12000 N	± 18000 N
Force z	21000 ± 5500 N	21000 ± 10000 N
Torque xy	± 32000 Nm	± 39000 Nm
Torque z	± 6000 Nm	± 13000 Nm

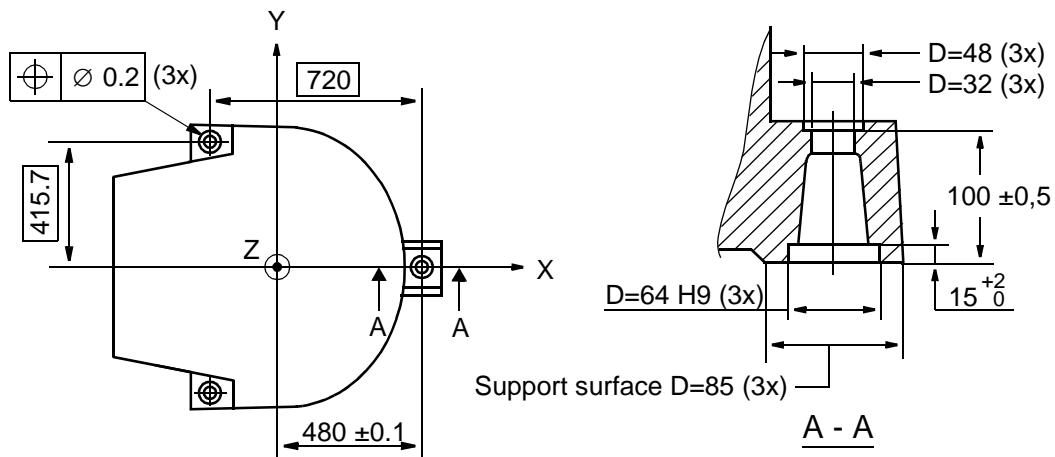
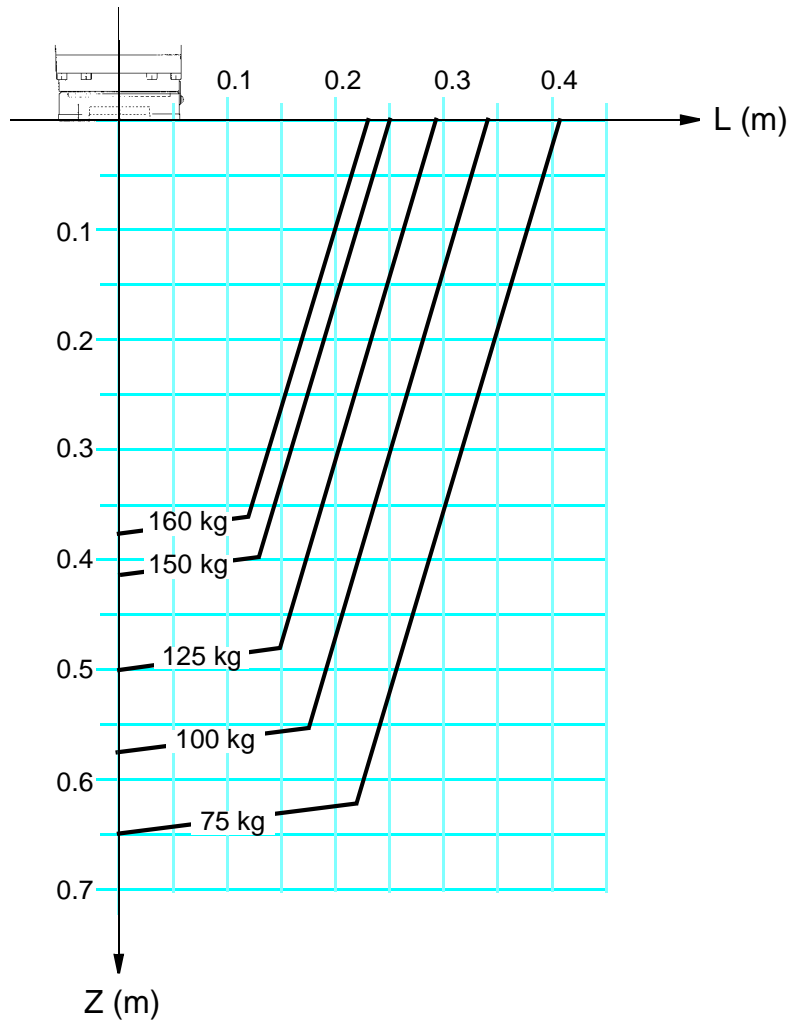

Figure 3 Hole configuration (dimensions in mm).

Description

Load diagram



The load diagram is valid for $J_0 < 100 \text{ kgm}^2$.
 J_0 = the maximum component (J_{X0} , J_{Y0} , J_{Z0}) of the moment of inertia of the handling weight at its centre of gravity.

Figure 4 Maximum weight permitted for load mounted on the mounting flange at different positions (centre of gravity).

Mounting equipment

Extra loads can be mounted on the upper arm and the frame. Definitions of distances and masses are shown in Figure 5 (upper arm) and in Figure 6 (frame). The robot is supplied with holes for mounting extra equipment (see Figure 7).

Upper arm

Permitted extra load on upper arm plus the maximum handling weight (See Figure 5):

$M1 \leq 35 \text{ kg}$ with distance $a \leq 500 \text{ mm}$, centre of gravity in axis 3 extension

or

$M2 \leq 35 \text{ kg}$ with distance $b \leq 400 \text{ mm}$

If the handling weight is lower than the maximum weight, the upper arm load can be increased.

For example, if the handling weight is only 120 kg, which is 40 kg less than max. handling capacity, you can put additional 40 kg on top of M1 or M2 on the upper arm. These “additional 40 kg” can be mounted in any of the holes for extra equipment.

The upper arm load should then be defined in the software as one mass. It is important that this is done correctly to ensure that the robot’s motions remain perfect.

For more information, see User’s Guide - *System Parameters*.

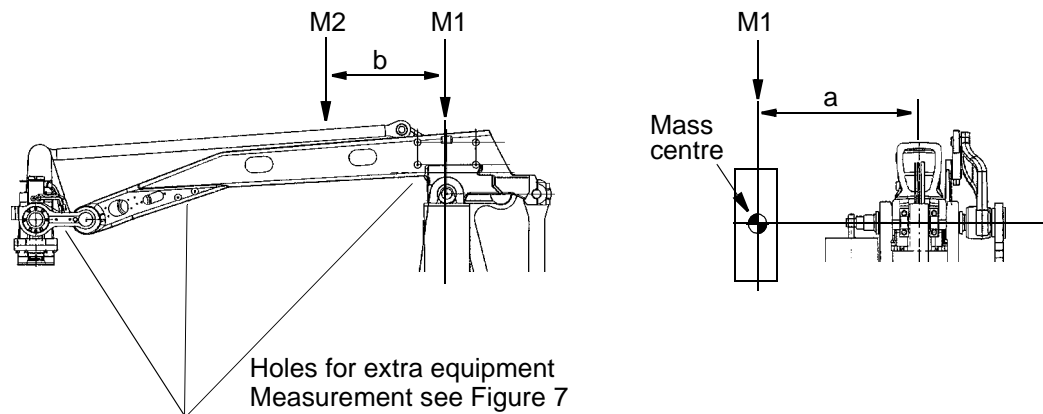

Figure 5 Permitted extra load on upper arm.

Description

Frame (Hip Load)

Permitted extra load on frame is $J_H = 120 \text{ kgm}^2$.

Recommended position (see Figure 6).

$$J_H = J_{H0} + M4 \cdot R^2$$

where J_{H0} is the moment of inertia of the equipment
 R is the radius (m) from the centre of axis 1
 $M4$ is the total mass (kg) of the equipment including bracket and harness ($\leq 320 \text{ kg}$)

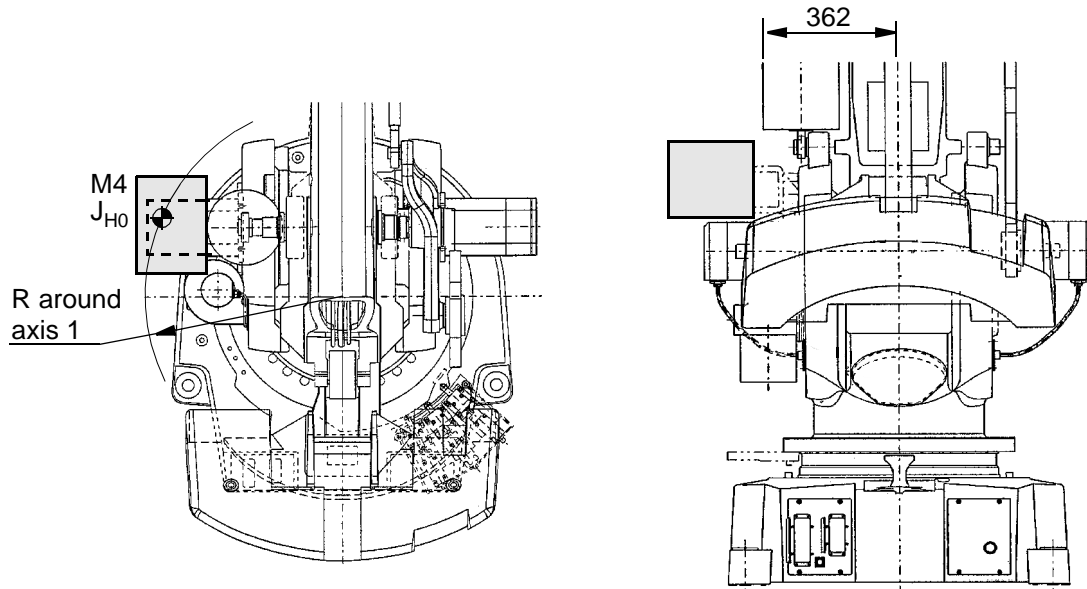

Note!

Hip load can only be mounted on the robot's left side.

Forklift device on the right side must be dismantled before using the robot.

Figure 6 Extra load on frame of IRB 640 (dimensions in mm).

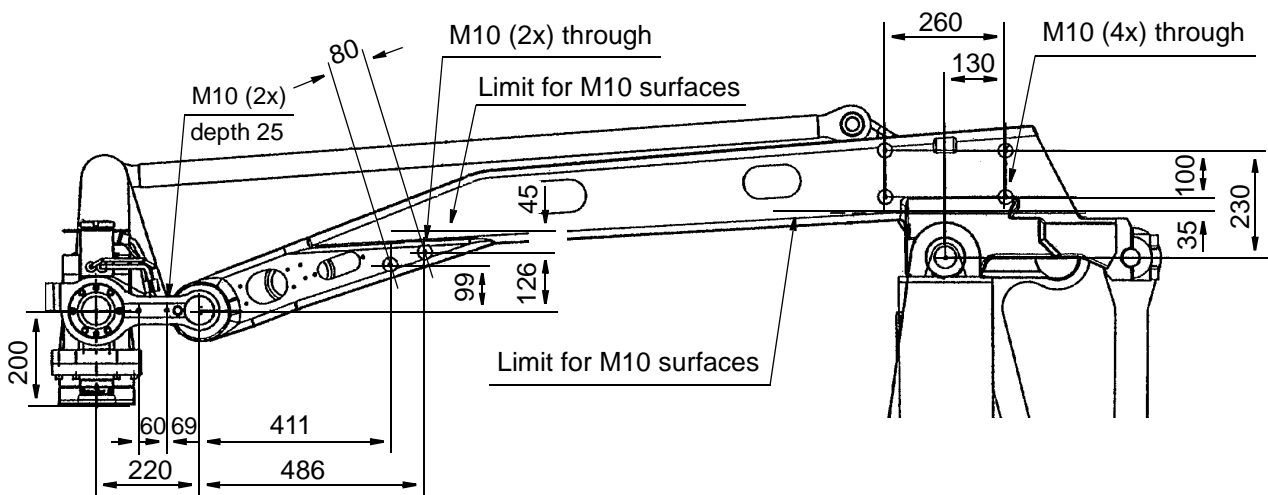

Figure 7 Holes for mounting extra equipment (dimensions in mm).

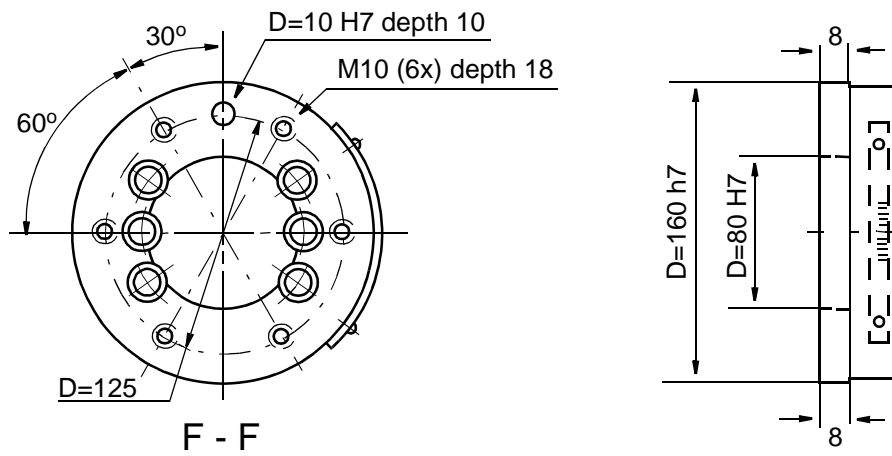

Figure 8 The mechanical interface (mounting flange) ISO 9409-1-A125 (dimensions in mm).

1.4 Maintenance and Troubleshooting

The robot requires only a minimum of maintenance during operation. It has been designed to make it as easy to service as possible:

- Maintenance-free AC motors are used.
- Liquid grease or oil is used for the gear boxes.
- The cabling is routed for longevity, and in the unlikely event of a failure, its modular design makes it easy to change.

The following maintenance is required:

- Changing grease and oil every third year.
- Changing batteries every third year.
- Some additional checks every year.

The maintenance intervals depends on the use of the robot. For detailed information on maintenance procedures, see Maintenance section in the Product Manual.

1.5 Robot Motion

Type of motion	Range of movement
Axis 1 Rotation motion	+180° to -180°
Axis 2 Arm motion	+70° to -70°
Axis 3 Arm motion	+85° to -28°
Axis 6 Turn motion	+300° to -300°

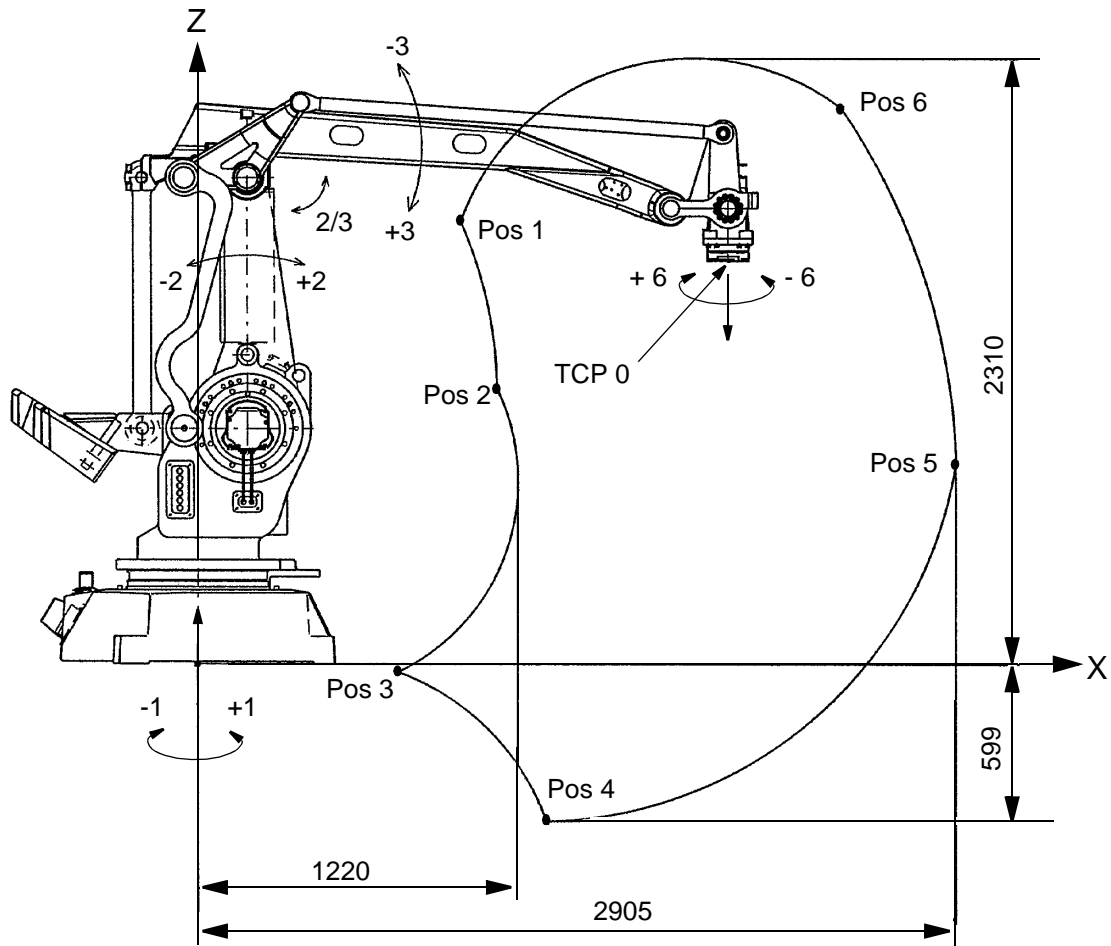

Positions at TCP 0 (mm)

Pos	X	Z
0	2028	1536
1	999	1685
2	1139	1053
3	761	-31
4	1328	-599
5	2905	770
6	2464	2119

Angle 2/3 (φ_2/φ_3)
 Min. 25° Max. 155°
 90° at pos. 0

pos.	axis 2 (φ_2)	axis 3 (φ_3)
0	0°	0°
1	-70°	-28°
2	-70°	-5°
3	40°	85°
4	70°	85°
5	70°	5°
6	37°	-28°

Figure 9 The extreme positions of the robot arm.

Velocity

Axis no.	1	125°/s
	2	125°/s
	3	125°/s
	6	275°/s

There is a supervision function to prevent overheating in applications with intensive and frequent movements.

Resolution

Approx. 0.01° on each axis.

1.6 Signals

More information of signals on upper arm on page 15.

Signal connections on robot arm

Signals	23	50 V, 250 mA
Power	10	250 V, 2 A
Air	1	Max. 10 bar, inner hose diameter 11 mm

DeviceNet

Signals	12	50 V, 250 mA
Power	5	250 V, 2 A
Air	1	Max. 10 bar, inner hose diameter 11 mm

Customer Power Vacuum (option 96-1)

Power	6	400 V, 4 A
Protective earth	2	

Description

2 Specification of Variants and Options

The different variants and options for the IRB 640 are described below.
The same numbers are used here as in the Specification form. For controller options, see Product Specification S4Cplus, and for software options, see Product Specification RobotWare Options.

1 MANIPULATOR

435-39 IRB 640

Manipulator colour

- 209-1** The manipulator is painted with ABB orange.
209-4-192 Colours according to RAL-codes.
209-3 ABB white Flex Palletizer

APPLICATION INTERFACE

Air supply and signals for extra equipment to upper arm

Standard (requires option 051 Standard)

Integrated hose for compressed air. There is an inlet at the base (see Figure 10) and an outlet on the tilthouse (see Figure 11). Connections: R1/2".

For connection of extra equipment on the manipulator, there are cables integrated into the manipulator's cabling and two connectors:

- one Burndy 23-pin UTG 018-23S
- one Burndy 12-pin UTG 014-12S

DeviceNet (requires option 17-1 DeviceNet)

Integrated hose for compressed air. There is an inlet at the base (see Figure 10) and an outlet on the tilthouse (see Figure 11). Connections: R1/2".

For connection of extra equipment on the manipulator there is a CAN cable (length from the hole on the upper arm: 645 mm) integrated into the manipulator's cabling. The connectors are:

- one Burndy 23-pin (12 available) UTG 018-23S
- one Burndy 12-pin (5 available) UTG 014-12S
- one CAN DeviceNet 5-pole female connector (Ø 1")

Connection of signals to

- 16-2** Manipulator
The signals are connected directly to the robot base to one Harting 40-pin connector. The cables from the manipulator base are not supplied.
- 16-1** Cabinet
The signals are connected to 12-pole screw terminals, Phoenix MSTB 2.5/12-ST-5.08, in the controller. The cable between R1.CP/CS and the controller is supplied.

Specification of Variants and Options

Connectors type

Type of fieldbus connectors on the upper arm

17-1 DeviceNet

5-pin “Mini” style female contact with 7/8-16 UN-2A THD female connection thread. Meets ANSI/B93.55M-1981 design and intermateability requirements.

Connection to cabinet (Cable lengths)

Standard

94-1	7m
94-2	15m
94-3	22m
94-4	30m

DeviceNet

90-2	7m
90-3	15m
90-4	22m
90-5	30m

96-1 Customer power vacuum

Cabling from the manipulator’s base to the left side of the frame (for connection with a vacuum pump, see Figure 10).

On the base one Burndy 23 pin UTG 018-23S. On the left side of the manipulator’s frame the cable ends with six wires + two protective earth.

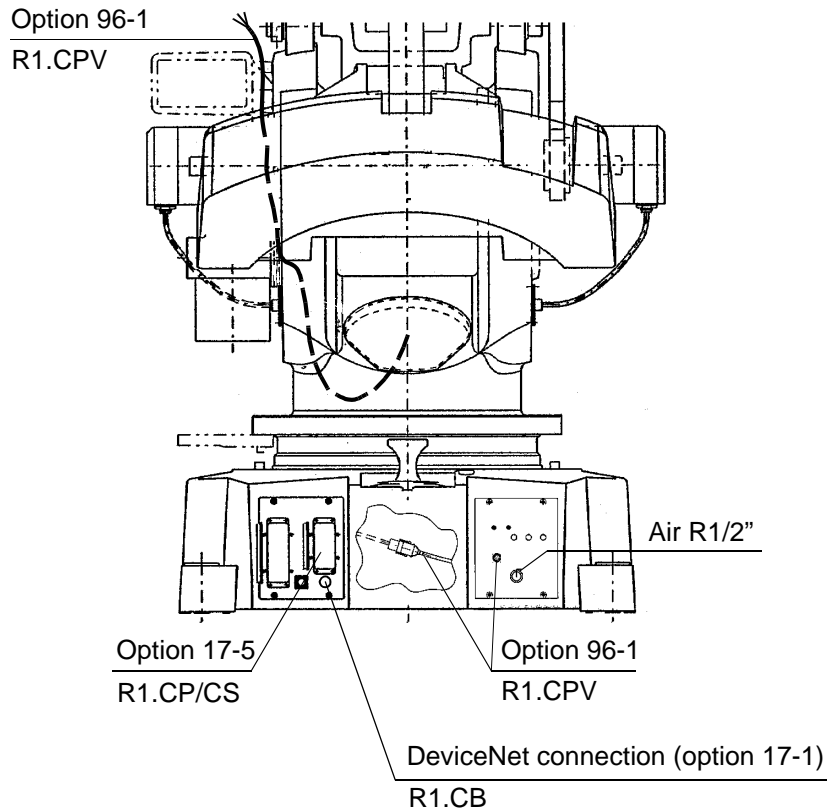

Figure 10 Connections at the manipulator base.

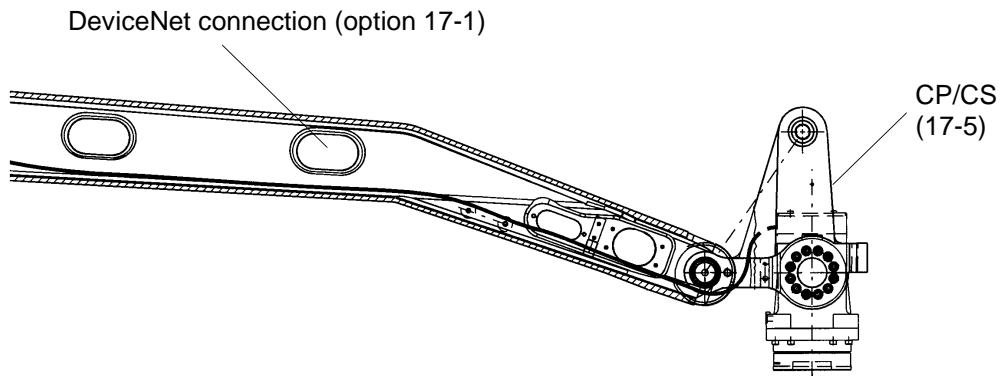

Figure 11 Connection of signals on the upper arm.

EQUIPMENT

213-1 Safety lamp

A safety lamp with an orange fixed light can be mounted on the manipulator. The lamp is active in MOTORS ON mode. The safety lamp is required on a UL/UR approved robot.

159-1 Fork lift device

Lifting device on the manipulator for fork-lift handling is mounted at delivery. Lifting eyes for use with an overhead crane are integrated as standard.

50-1 Brake release cover

Protective cover over push-buttons on brake release unit.

POSITION SWITCH

Position switches indicating the position of one or two of the main axes. Rails with separate adjustable cams are attached to the manipulator. The cams, which have to be adapted to the switch function by the user, can be mounted in any position in the working range for each switch.

The position switch device is delivered as a kit to be assembled when installing the robot. Assembly instruction is included.

Note! This option may require external safety arrangements, e.g. light curtains, photocells or contact mats.

Note! The switches are not recommended to be used in severe environment with sand or chips.

1, 2 or 3 switches indicating the position of axis 1.

Switch type: Telemecanique XCK-M1/ZCK-D16, 2 pole N/C + N/O, according to IEC 947-5-1.

Specification of Variants and Options

- 25-2** 1 switch, axis 1
- 25-4** 2 switches, axis 1
- 25-3** 3 switches, axis 1
- 30-1** 1 switch, axis 2

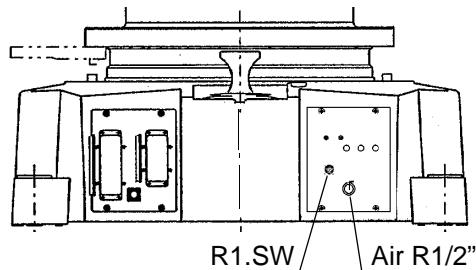

Figure 12 Connection of position switch cable to the base.

Connection to

271-2 Manipulator

Connection on the manipulator base with one FCI 23-pin connector.

271-1 Cabinet

The signals are connected to 12-pole screw terminals, Phoenix MSTB 2.5/12-ST-5.08, in the controller. The cable between the manipulator base R1.SW and the controller, is included.

Connection of signals (Cable lengths)

- 273-1** 7m
- 273-2** 15m
- 273-3** 22m
- 273-4** 30m

WORKING RANGE LIMIT

To increase the safety of the robot, the working range of axes 1, 2 and 3 can be restricted by extra mechanical stops.

28-1 Axis 1

2 stops which allow the working range to be restricted in any increment of 20°.

32-1 Axis 2

6 stops which allow the working range to be restricted in increments of 20°. Each stop decreases the motion by 20°. This means that the motion can be decreased by 6 x 20° from the maximum axis motion.

34-1 Axis 3

6 stops which allow the working range to be restricted in increments of 20°. Each stop decreases the motion by 20°. This means that the motion can be decreased by 6 x 20° from the maximum axis motion.

3 Accessories

There is a range of tools and equipment available, specially designed for the robot.

Basic software and software options for robot and PC

For more information, see Product Specification S4Cplus, and Product Specification RobotWare Options.

Robot Peripherals

- Track Motion
- Tool System
- Motor Units

Accessories

4 Index

A

accessories 19
air supply 15

C

cooling device 3

E

emergency stop 6
enabling device 5
equipment
 mounting 9
 permitted extra load 9
extra equipment
 connections 15

F

Fire safety 6
fork lift device 17

H

hold-to-run control 6
humidity 7

I

installation 6

L

load 6, 7

M

maintenance 11
mechanical interface 11
motion 12
mounting
 extra equipment 9
 robot 7
mounting flange 11

N

noise level 3

O

operating requirements 7
options 15
overspeed protection 6

P

payload 6
position switch 17
protection standards 7

R

range of movement 12
reduced speed 5
Robot Peripherals 19

S

safe manual movement 6
safeguarded space stop 6
 delayed 6
safety 5
Safety lamp 17
safety lamp 6
service 11
service position indicator 17
signal connections 15
space requirements 3
standards 5
structure 3

T

temperature 7
troubleshooting 11

V

variants 15

W

weight 3
WORKING RANGE LIMIT 18
working space
 restricting 6

Index