

# Optimized Power Semiconductors for the Power Electronics Based HVDC Breaker Application

Liutauras Storasta, ABB Switzerland Ltd, Semiconductors, liutauras.storasta@ch.abb.com  
Munaf Rahimo, ABB Switzerland Ltd, Semiconductors  
Jürgen Häfner, ABB AB, HVDC, Sweden  
Franc Dugal, ABB Switzerland Ltd, Semiconductors  
Evgeny Tsyplakov, ABB Switzerland Ltd, Semiconductors  
Magnus Callavik, ABB AB, HVDC, Sweden

The Power Point Presentation will be available after the conference.

## Abstract

In the field of power electronics applications, advances in high voltage semiconductor devices have led specifically over the past few decades to tremendous improvements in terms of power handling capability and control. We focus in this paper on the recent developments with regard to optimizing the power semiconductor for the solid state HVDC breaker for HVDC grid applications. One of the traditional approaches for the development of power semiconductors is to achieve full integration of the active power semiconductor switch and the anti-parallel freewheeling diode. The main aim for such a trend is to obtain higher power densities and more compact systems while at the same time simplifying the component manufacturability by eliminating the need for a separate anti-parallel diode. Recent development efforts over the past few years targeted a fully integrated high voltage and high current IGBT and diode structure on a single chip. As a result, an RC-IGBT type device was realized recently and referred to as the Bi-mode Insulated Gate Transistor BIGT. The BIGT was designed in accordance with the latest IGBT design concepts while fully incorporating an optimized integrated anti-parallel diode in the IGBT structure. This paper will mainly focus on the application of the BIGT especially for the power electronics based Hybrid HVDC breaker application while presenting an overview of the recent advancements from the device design and performance viewpoint. Recent experimental data obtained from tests carried out on prototype samples will also be presented.

## 1. Introduction

In modern power electronics applications employing IGBT modules, the diode presents a major restriction with regard to its losses performance and surge current capability. Both limits are a result of the typically limited diode area available in a given package footprint design. In particular, these limits were further restricted after the introduction of modern low-loss IGBT designs. Therefore, the simple approach of increasing the diode area is not a preferred solution and in any case remains constrained by the package standard footprint designs. Nevertheless, the clear demand for increased power densities of IGBT and diode components has led to the focus on an IGBT and diode integration solution, or what has been normally referred to as the Reverse Conducting (RC) IGBT. An advanced RC-IGBT device referred to as the BIGT (see Figure 1) was developed depending on the diode optimization requirements to include either an integrated fast recovery diode for mainstream converter applications or a rectifier like diode with slow diode switching performance and low conduction losses. The latter is targeted for applications such as the recently developed Hybrid HVDC breaker with low conduction losses and event switching requirements. The optimized BIGT devices are packaged in the StakPak which is optimized for a series connection assembly for providing a highly flexible modular

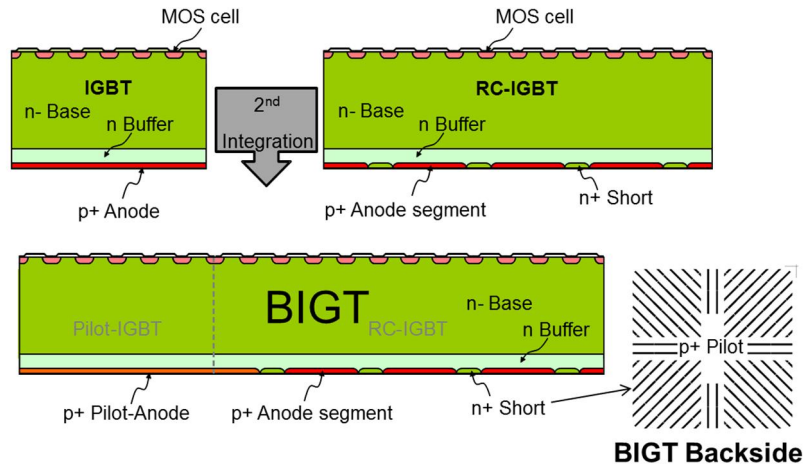

Fig. 1. The BIGT Concept

platform for current and voltage scaling. In addition, the StakPak delivers the ability to carry the load current in a failed module. In the following sections, we will introduce the recently developed BIGT based Stakpak which was specifically designed for improving the current conduction and high current turn-off switching capability for a power semiconductor based Hybrid HVDC breaker.

## 2. Design optimization of the BIGT device for Breaker application

The BIGT is an advanced reverse conducting IGBT device concept which targets replacing high voltage IGBTs and diodes in the next generation systems [1]. The BIGT is a two-step integrated structure: The first integration follows the standard approach where an RC-IGBT is formed by combining both an IGBT and diode in a single structure. At the collector side, alternating n+ doped areas are introduced into an IGBT p+ anode layer, which then act as a cathode contact for the internal diode mode of operation. The area ratio between the IGBT anode (p+ regions) and the diode cathode (n+ regions) determines which part of the collector area is available in IGBT or diode modes, respectively. During the RC-IGBT conduction in diode mode, the p+ regions are in-active and do not directly influence the diode conduction performance. However on the other hand, the n+ regions act as anode shorts in the IGBT mode of operation, strongly influencing IGBT conduction mode.

One of the implications of anode shorting is the voltage snapback referred to previously which is observed as a negative resistance region in the device IGBT mode I-V characteristics. This effect will have a negative impact when devices are paralleled, especially at low temperature conditions. To resolve this issue, a second integration step was required. It has been shown that the initial snap-back can be controlled and eliminated by introducing wide p+ regions into the device, also referred to as a pilot-IGBT. This approach resulted in the BIGT concept which in principle is a hybrid structure consisting of an RC-IGBT and an IGBT in a single chip as shown in Figure (1).

The pilot area is centralized in the middle to obtain better thermal distributions and reduced current non-uniformities and is also designed to provide the outermost reach within the chip while ensuring a large RC-IGBT region. A striped structure is deployed for the alternating p+ and n+ regions with an optimized radial layout to ensure smooth and fast transition in the IGBT conduction mode from the pilot area to rest of the chip. To further improve the on-state losses, the radial design of the anode shorts is employed [2]. The BIGT technology is initially being developed for high voltage devices and has been demonstrated at module level with voltage ratings ranging from 3.3 kV and up to 6.5 kV.

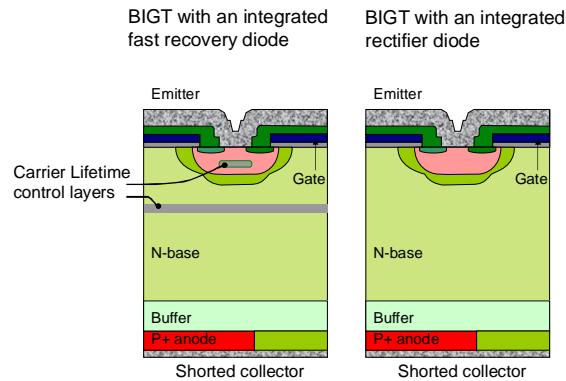

Fig. 2. Optimization of the BIGT for the HVDC breaker

The BIGT device can operate in both freewheeling diode mode and (IGBT) transistor mode by utilizing essentially the same available silicon volume in both modes. As all the chips in the module are able to operate in both modes, available silicon area can be increased considerably compared to the standard modules. The thermal resistance between the junction and the case is also reduced accordingly.

For achieving a good BIGT diode mode switching performance, several measures have to be applied [3]: optimization of the doping profiles of the p-well of the MOS cells for low injection efficiency, carrier lifetime control in the p-well, and additionally a uniform carrier lifetime adjustment in the n-base. However, the latter process comes with a penalty in on-state conduction losses as it reduces carrier plasma concentration in both IGBT and diode modes. This limits the output current capability of the chip especially at low frequencies.

While the mainstream conversion applications require low switching losses in the diode mode, for event switching applications such as an HVDC breaker, the BIGT diode can undergo a different optimization. With no fast recovery requirements, the lifetime control layers in the BIGT can be simply omitted, resulting in a rectifier like reverse recovery behavior, see Figure 2. The absence of lifetime control layers raises the carrier plasma level in the device thus significantly lowering the IGBT and diode on-state losses when compared to a BIGT optimized for fast diode switching. The lower conduction losses in both direction is a very important feature for the HVDC breaker performance.

### 3. BIGT in the StakPak

The BIGT devices are employed in the StakPak package (Figure 3) which is optimized for a series connection stack assembly for providing a highly flexible modular platform for current and voltage scaling and having the ability to carry the load current in a failed module. In the following section, we will introduce the recently developed BIGT based StakPak which was specifically designed for improving the current conduction and switching capability for a power semiconductor based Hybrid HVDC breaker.

The traditional StakPak module is normally integrating the IGBT and the anti-parallel diode as well as providing a highly flexible modular platform for power scaling of the device while increasing the flexibility in the IGBT/diode ratio [4]. It also maintains the individual chip contacts through the press pin which increase the cooling capacity and enable a relaxation of the flatness tolerance on the stacking cooler. But the major StakPak advantage for series connection applications is for having the ability for a failed module to still carry the load current. In other words, any chip failure will lead to a short circuit rather than open circuit failure as it is



Fig. 3. The StakPak module

the case for insulated IGBT modules. This ability of the module to fail into a stable low impedance state is referred as Short Circuit Failure Mode (SCFM).

The StakPak module consists of a number of standard rectangular sub-units, named as sub-modules. In this way, power is configured into the switch based on the number of sub-modules, 2, 4 or 6 contained in the frame. The layout of the IGBT connections allows for different IGBT:diode ratios in the submodule. The current rating therefore depends on this ratio. As an example, a module with 6 submodules and a 1:1 ratio is rated at 2000A, when with a 2:1 ratio it will be rated at 2600A. Since every BIGT integrated structure can operate in both IGBT and diode modes, it will therefore provide much higher current rating for a given footprint area: the 6 submodule version of the StakPak can be rated up to 3000 A while a 4 submodule version will achieve 2000 A without deteriorating diode performance.

The optimized BIGT discussed in this paper was rated at 4500 V and packaged in a StakPak containing 6 submodules with a current rating of 3000 A (500 A per submodule). The BIGT submodules were tested under static and dynamic conditions similar to those applied to state-of-the-art IGBT modules. The on-state characteristics of the BIGT submodule in IGBT and diode modes are shown in Figure 4 at 25°C and 125°C. An IGBT mode on-state of approximately 2.75 V at 125°C is shown at the 500 A nominal current. In the reverse direction,

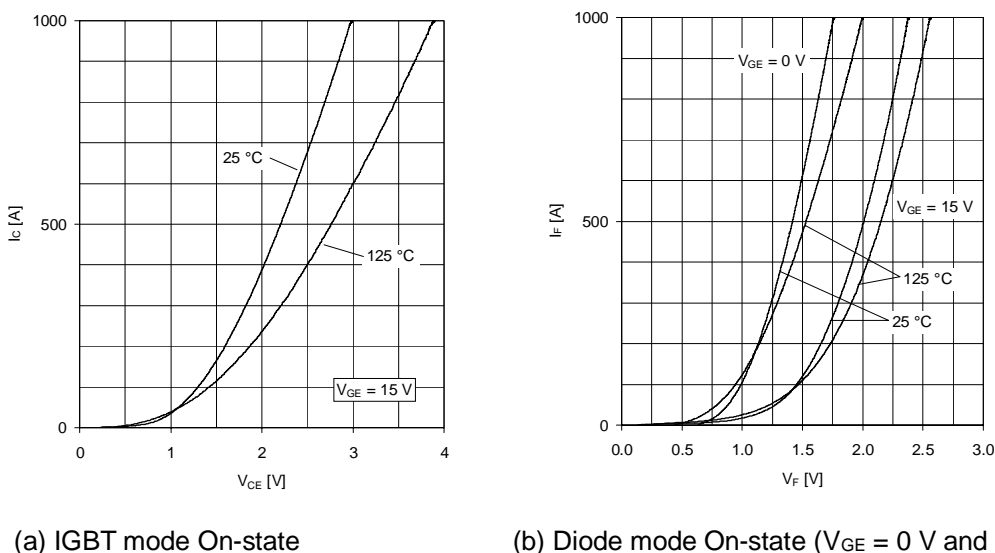

Fig. 4. 4.5 k V / 500 A BIGT submodule on-state characteristics in IGBT mode (forward conduction) and diode mode (reverse conduction) at 25°C and 125°C.

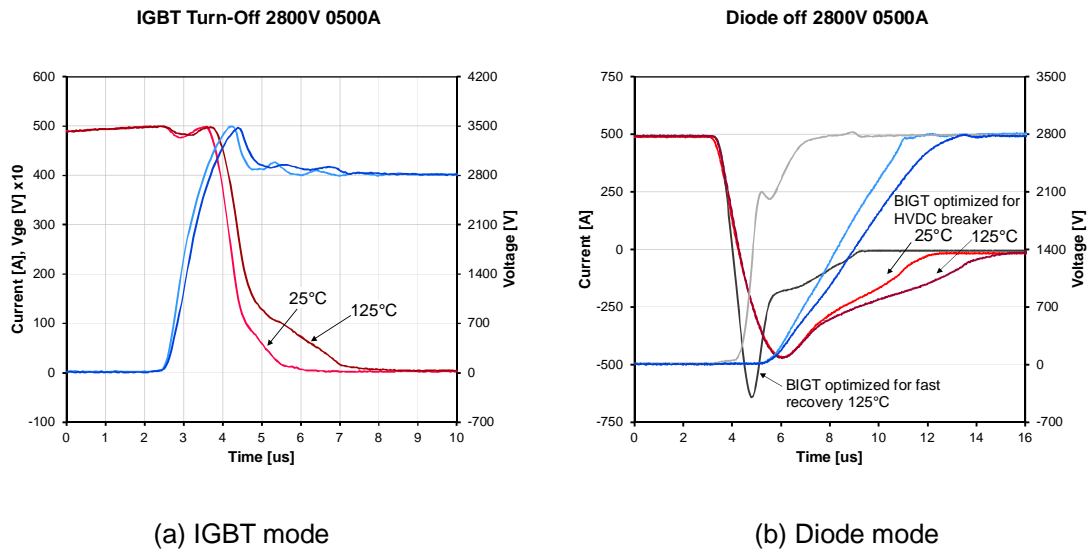

Fig. 5. 4.5kV/500A BIGT submodule IGBT / diode mode nominal turn-off waveforms at 25°C and 125°C. Diode mode is compared to a BIGT optimized for fast recovery applications

the diode mode in a BIGT is dependent on the applied gate emitter voltage due to the shorting of the BIGT MOS cell at positive gate voltages above the threshold voltage level [5]. Therefore, at 500 A and 125°C, with no applied gate voltage, the diode has a forward voltage drop of 1.55 V compared to 2.15 V at 15 V. In addition, for safe paralleling of chips, the curves show a strong positive temperature coefficient even at very low currents in both modes of operation.

The switching characteristics of the BIGT submodule in IGBT and diode modes are presented in Figure 5 at 25°C and 125°C. The diode switching mode is shown in comparison with a BIGT device optimized for the mainstream conversion applications requiring low switching losses in the diode mode. The HVDC breaker optimized BIGT has evidently higher diode turn-off losses, however, this is not a limiting factor for a single event switching application. The benefit becomes clear when comparing the conduction losses of both devices: the fast recovery optimized device has on-state voltage in the range of 3 V at nominal current and 125°C with no applied gate voltage, compared to 1.55 V of the HVDC breaker optimized device. For the IGBT mode, the on-state voltage of the fast version BIGT is around 3.3 V compared the HVDC breaker BIGT version at 2.75 V.

#### 4. The BIGT in the Hybrid HVDC Breaker Application

A novel Hybrid HVDC breaker designed specifically for HVDC grid systems has been recently introduced outlining in detail the principle of operation and operational modes [6]. The modular Hybrid HVDC breaker shown in Figure 6 consists of an additional bypass branch in parallel to the main semiconductor based HVDC current breaker. The bypass is formed by an auxiliary semiconductor based HVDC breaker (load commutation switch) in series with an ultrafast mechanical dis-connector. The main semiconductor based HVDC breaker is separated into several sections with individual arrester banks dimensioned for full voltage and current breaking capability, whereas the load commutation switch matches a lower voltage and current breaking capability. After fault clearance, the disconnecting residual DC current breaker isolates the faulty line from the HVDC grid to protect the arrester banks of the Hybrid HVDC breaker from thermal overload.

The breaking current capability was verified and the results to be presented were for a scaled down breaker employing three series connected 4.5 k V optimized BIGT StakPaks with 6

submodules. A fourth module was also connected opposite to the primary current direction to verify the functionality of the BIGT diode mode. Discharge of a capacitor bank by a thyristor switch, limited only by a minor DC reactor, represents pole to ground faults in the DC grid. The DC voltage level prior to the fault and after fault clearance is less critical since the voltage stress across the semiconductor component HVDC breaker positions during the current breaking depends on the applied arrester bank only.

The main aim of the first Hybrid HVDC breaker demonstrator [6] was to achieve initially a current breaking capability of 9 kA for an IGBT-based main breaker. However, with the ultimate goal of a current breaking capability of 16 kA at operating times within 5 ms (including the time delay of the protection system), a BIGT-based main breaker is demonstrated here for an HVDC grid with a rated voltage of 320 kV and a rated HVDC transmission current of 2 kA.

The series connected HVDC breaker StakPak positions commute the line current within 2µs into the RCD snubber circuits, which limits the rate of rise of the voltage across the positions to 300V/µs. Zero voltage switching reduces the instantaneous switching losses and ensures an equal voltage distribution independent of the tolerances in the switching characteristics of the applied semiconductor modules. The line current commutates from the RCD snubber circuit into the arrester path after the common voltage across the Stakpak HVDC breaker positions reaches the protective level of the arrester bank. In the first tests [6], the IGBT based HVDC breaker positions passed the stress tests for breaking currents below 10kA. Then, it was demonstrated that the maximum breaking current capability of the IGBT HVDC breaker

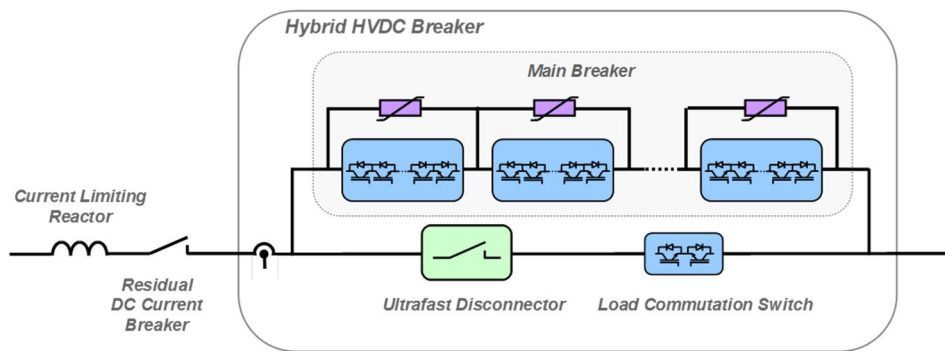

Fig. 6. Modular Hybrid HVDC breaker

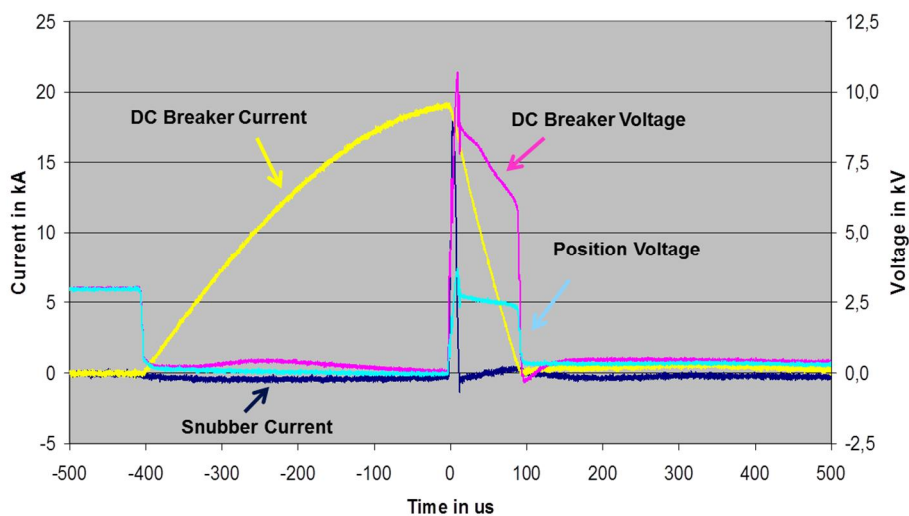

Fig. 7: Maximum stress tests up to 19.1 kA on the BIGT HVDC breaker positions

cell is given by the saturation current of the applied IGBT modules rather than the safe operation area (SOA) as typical for voltage source converter applications. For higher currents, internal current limitation of the DC breaker positions at the IGBT saturation current level occurs with higher voltage drops across the IGBT modules resulting in internal heat dissipation within the module which destroys the encapsulated chips.

An increase in the maximum breaking current capability was expected to double with the utilization of the next generation BIGT technology incorporating the functionality of the reverse conducting diode on the IGBT chips. To verify the performance advantage of the BIGT, tests were carried out utilizing the same prototype set-up while employing three series connected 4.5 kV BIGT StakPaks with 6 submodules each for direct comparison with the equivalent IGBT StakPak. The BIGT StakPak was capable of breaking up to 19 kA representing the HVDC breaker current flowing through the main breaker path. This is approximately twice the breaking current levels achieved with the equivalent IGBT StakPak as shown in Figure 7.

## 5. Conclusions

The next generation power semiconductor; namely the BIGT was described with the main aim to enhance the performance of the Hybrid HVDC breaker. The new BIGT technology will enable lower losses and a comfortable maximum breaking current up to 16kA at operating times within 5ms including the time delay of the protection system. Therefore, high current proactive Hybrid HVDC breakers with increased breaking current capabilities are well suited for HVDC grids preventing a collapse of multi-terminal HVDC systems due to DC line faults. In principle, the BIGT technology represent an important step with the respect to the power semiconductor contribution for enabling emerging solid state power electronics based solutions such as the one described in this paper.

## 6. References

- [1]. M. Rahimo, A. Kopta, U. Schlapbach, J. Vobecky, R. Schnell, S. Klaka "The Bi-mode Insulated Gate Transistor (BiGT) A potential technology for higher power applications" Proc. ISPSD09, pp. 283-286, June 2009
- [2]. L. Storasta, M. Rahimo, M. Bellini, A. Kopta; "The Radial Layout Design Concept for the Bi-Mode Insulated Gate Transistor" Proc. ISPSD'11, p 56.
- [3]. L. Storasta, M. Rahimo, C. Corvasce, A. Kopta "Resolving Design Trade-offs with the BIGT Concept" Proc. PCIM2014, pp. 354-361, May 2014
- [4]. S. Eicher, M. Rahimo, E. Tsyplakov, D. Schneider, A. Kopta, U. Schlapbach, E. Caroll "4.5 k V Press Pack IGBT Designed for Ruggedness and Reliability" Proc. IAS, Seattle, pp. 1534-1539, Oct. 2004
- [5]. Papadopoulos, et al., "BIGT control optimization for overall loss reduction" EPE 2013 Lille, France.
- [6]. J. Häfner, B. Jacobson "Proactive Hybrid HVDC Breakers – A key innovation for reliable HVDC grids" Cigre Bologna, Paper 0264, 2011.