

# Motor Protection REM610

## Relion® 610 series

REM610 is a motor IED for the protection, measuring and supervision of medium sized and large asynchronous LV motors and small and medium-sized asynchronous HV motors in manufacturing and process industry. REM610 is a member of ABB's Relion® protection and control product family and part of its 610 product series. The 610 series includes protection IEDs for feeders, motors and for general system voltage supervision. The plug-in design of the 610 series IEDs facilitates the commissioning of the switchgear and enables fast and safe insertion and withdrawal of IED plug-in units.

### Application

The functionality of REM610 is primarily focused on the protection of large asynchronous low-voltage motors and small and medium-sized asynchronous high-voltage motors. The IED can be used with both circuit-breaker and contactor-controlled motor drives in a variety of applications in, for instance, process industry, public fresh and waste water facilities, fluid and gas pumping stations, power plants, marine and off-shore environments. Enhanced with an optional add-on card for RTD sensors or thermistor elements, the IED can be used for direct temperature measurement of critical motor items, such as bearings and windings. REM610 is also used for the protection of cable feeders and distribution transformers, which often benefit from thermal overload protection besides phase overcurrent protection, earth-fault protection and phase unbalance protection.

### Protection

The REM610 handles fault conditions during motor startup, normal operation, idling and cooling down at standstill. The key features of the motor IED include thermal overload protection, cumulative motor startup supervision, running stall protection, earth-fault protection, and loss-of-phase protection. Furthermore, the thermal overload protection function can be enhanced with an optional RTD module for



direct temperature measurement. The RTD module has six measuring inputs and supports PTC thermistors and RTD sensors.

### Disturbance recorder

The 610 series IEDs feature an integrated disturbance recorder for logging events and registering transient variables before, during and after a network disturbance situation. The disturbance recorder includes four analog channels and eight binary channels, which can be assigned by the user to the analog and digital signals requiring monitoring to enable subsequent post-fault analyses of power system events.

### Supervision

To ensure continuous availability of protection the 610 series IEDs feature extensive self-supervision of the function of the digital circuitry and the software. The IED also includes an integrated trip-circuit supervision function monitoring the external trip signal path. When a permanent IED fault is detected, the IED's protection stages and outputs will be blocked to prevent malfunction. Further, a LED indicator will light up and an alert message for remote fault indication will be generated.

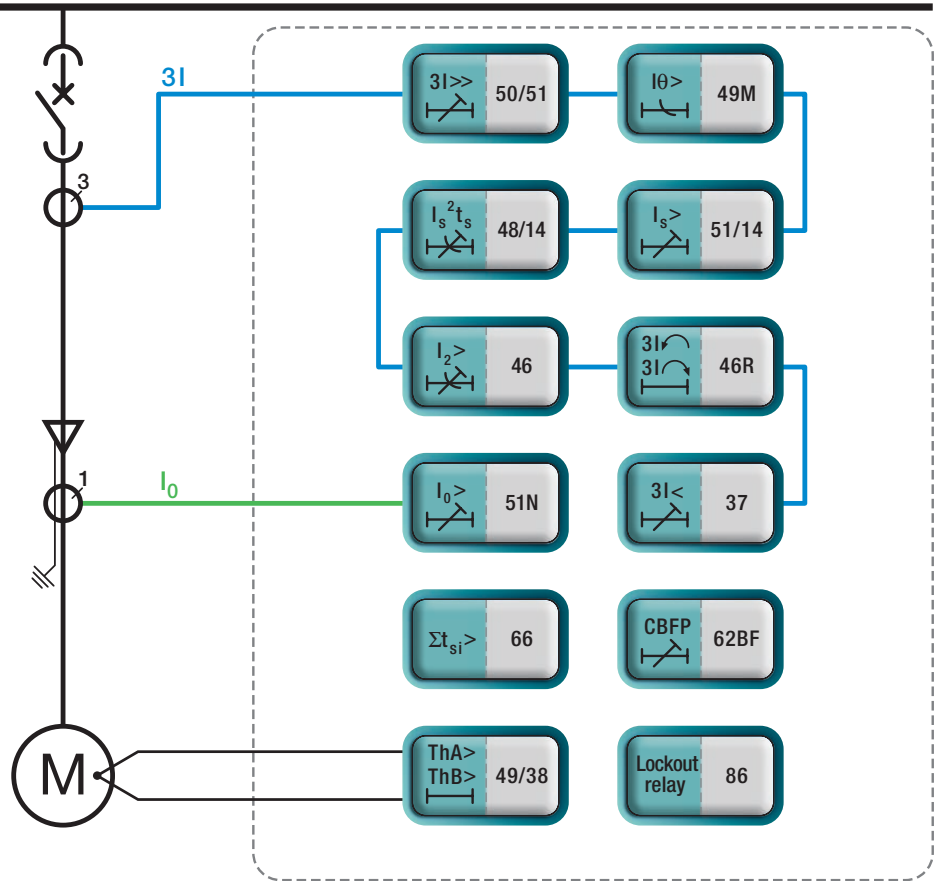

Protection function overview of REM610.

### Standardized communication

REM610 supports a wide range of standard communication protocols, including IEC 61850, IEC 60870-5-103, Modbus®, Profibus, SPA and LON.

### Unique plug-in design

The patented IED case and the plug-in type IED unit speed up installation, testing and maintenance of the device. A convenient pull-out handle with built-in release enables quick removal of the plug-in unit and insertion of a replacement unit. The IED case is fitted with an automatic short-circuiting mechanism to prevent hazardous voltages from arising in the CT secondary circuits should an IED unit be withdrawn from the case in live switchgear.

When an IED plug-in unit is inserted into the IED case for the first time, a mechanical coding system permanently adapts the case to the type of IED plug-in unit inserted.

### Universal case

The normal delivery mode for 610 series protection IEDs is a complete package including a case, a plug-in unit and a possible optional communication card. When a fair amount of IEDs are to be factory installed, e.g. by a panel builder,

or on-site installed in a retrofit project, it may be more convenient to obtain empty IED cases to be installed and tested together with the switchgear. The dispatch of the plug-in units can then be postponed until the switchgear has been erected on site and the IEDs are needed. For this purpose, the 610 series IEDs are provided with a universal case not assigned to any particular type of IED plug-in unit when delivered from the factory.

## For more information see REM610 Product Guide.

For more information please contact:

### ABB Oy, Distribution Automation

P.O. Box 699  
FI-65101 VAASA, Finland  
Phone: +358 10 22 11  
Fax: +358 10 22 41094

[www.abb.com/substationautomation](http://www.abb.com/substationautomation)