UPS BATTERY HANDBOOK

The Main Characteristics of UPS Battery Systems

Power protection for critical
infrastructure



Understanding UPS batteries helps to ensure a continuous flow of clean power.

—
01 The lifeblood of financial institutions is a reliable source of quality electrical power. This is why businesses install a UPS. The battery in a UPS is the most vulnerable part of the system.

A secure supply of energy is the foundation for the success and continuity of many enterprises – be they industrial plants, offices, healthcare facilities, utilities or data centers. For some of these concerns, power outages can be very expensive indeed, with costs sometimes running into the tens of millions of dollars. This is why many businesses install an uninterruptible power supply (UPS).

A critical part of the UPS is the battery bank that provides the energy needed to ensure that a continuous flow of clean power is available to the critical process that the UPS is powering. Parameters that have to be taken into consideration in properly selecting battery systems are the desired power and autonomy, inverter efficiency, final discharge, and available charging voltage. These and many other factors must be carefully considered when choosing and configuring a UPS battery system.

This handbook describes the main characteristics of UPS battery systems, with particular emphasis on the lead–acid battery type, as these are in widespread use.

Further information can be found in national and international standards, such as “BS EN 50272-2:2001– Safety requirements for secondary battery and battery installations – Stationary batteries,” released by the European Committee for Electrotechnical Standardization.



Batteries in UPS systems

01 Internal and external components of a valve-regulated lead-acid (VRLA) battery

UPS applications make use of a wide variety of battery types; however, lead-acid (LA) batteries are currently the most common technology. In specific instances with special requirements, nickel-cadmium or lithium-ion batteries are sometimes used. Lithium-ion is a rapidly growing battery technology, used where high-energy density and low weight are the primary requirements.

Lead-acid batteries

The LA battery represents the most economical choice for larger power applications where weight is of little or no concern. Most UPS systems use LA batteries as they provide excellent performance, high power efficiency with low internal impedance, high tolerance to improper treatment, and attractive purchasing costs.

LA batteries use an electrolyte that consists of water and sulfuric acid, and plates made up of sponge lead (negative electrode) and lead oxide (positive). The two main LA battery types are:

- VRLA (valve-regulated lead-acid), also known as “sealed” or “maintenance-free”
- Flooded, also called “vented” or “open”

VRLA batteries

VRLA batteries are sealed and can be mounted in any orientation. The battery case is equipped with a valve that vents any buildup of gas externally. Gas buildup is usually an exceptional event, which may occur, for example, when the battery is subject to a high charging rate or rapid discharge. VRLA batteries normally require no direct maintenance – they do not need to be topped up with water, as any hydrogen released during charging is recombined internally with oxygen to form water. There are two main VRLA types, distinguished by their electrolyte composition:

- Absorbed glass material (AGM), where the electrolyte is held within a highly porous microfiber glass separator.
- Gel, which has an electrolyte gel made from a mixture of sulfuric acid and silica.

UPS applications normally work with the VRLA AGM type because of its lower internal resistance, high specific power and efficiency, low self-discharge, and lower purchasing costs. AGM batteries also charge faster and can deliver high current of short duration.

01

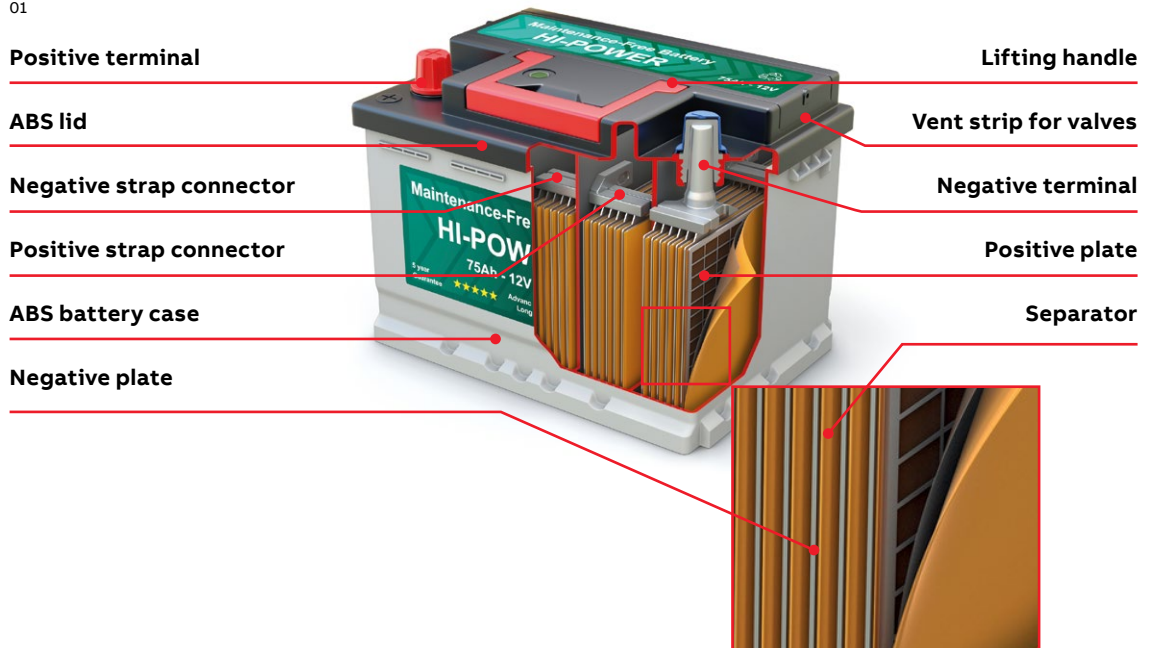

—
01 These graphs compare NiCd with different LA battery types. Active material composition varies by manufacturer, so performance may vary from case to case.

Flooded batteries

Flooded LA batteries, as the name suggests, have plates that are immersed in an acid electrolyte. Since they are not sealed, the hydrogen generated during operation escapes directly into the environment, meaning that ventilation systems must be more powerful than those for VRLA and, so, sized adequately. In most cases, the battery banks are accommodated in a dedicated room. DIN VDE 0510 Part 2, for example, sets out the provisions for equipping such a battery room. Flooded batteries must be kept and operated upright, and their water levels must be manually topped up. They provide a longer lifespan and higher reliability than sealed LA batteries.

Nickel–cadmium batteries

Nickel–cadmium (NiCd) battery electrodes are made of nickel hydroxide (positive plate) and cadmium hydroxide (negative plate). The electrolyte is an aqueous solution of alkaline potassium hydroxide. NiCd batteries provide a very long calendar life (up to 20 years) and can cope with temperature extremes (-20 °C to +40 °C). They also offer a high cycle life and have good tolerance to deep discharges. However, NiCd batteries cost much more than traditional VRLA equivalents.

—
01

Nickel–Cadmium

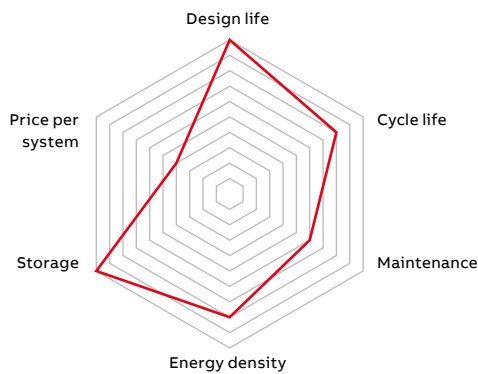

Lead–Acid AGM

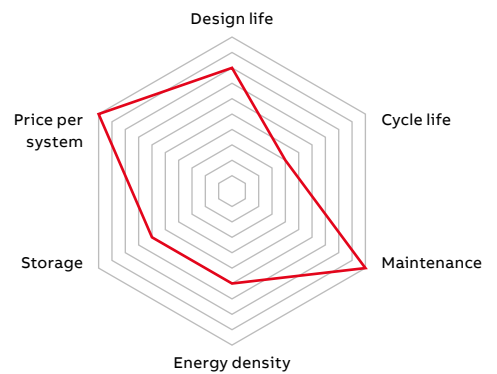

Lead–Acid Gel

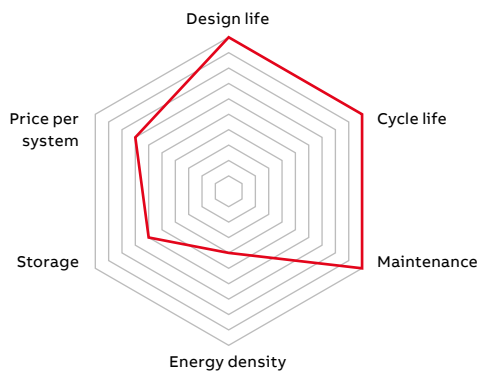

Lead–Acid Flooded

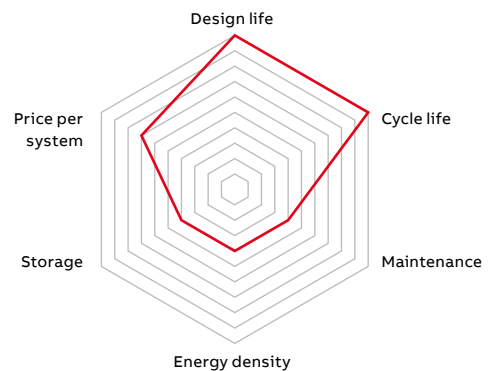

—
01 Internal and external components of a flooded battery

—
02 Internal and external components of nickel-cadmium battery

Other benefits relate to the low internal resistance, which offers high power density combined with fast-charging capability. The storage time of NiCd batteries is very long, especially if fully discharged, and they provide high protection against improper treatment – e.g., overcharging, over-discharging, and high-ripple charging cur-

rents. Further, as both nickel and cadmium are toxic, battery disposal/recycling processes are costly. NiCd batteries also require maintenance in the form of topping up with water – especially in high-cycle applications, or under heavy charging rates with some charging methodologies.

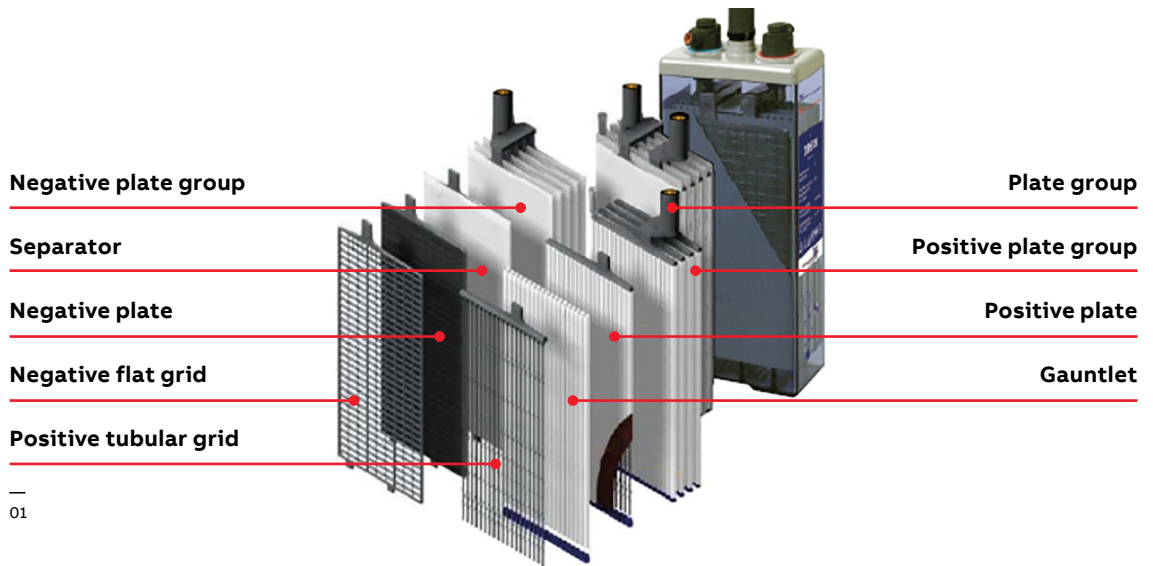

—
01

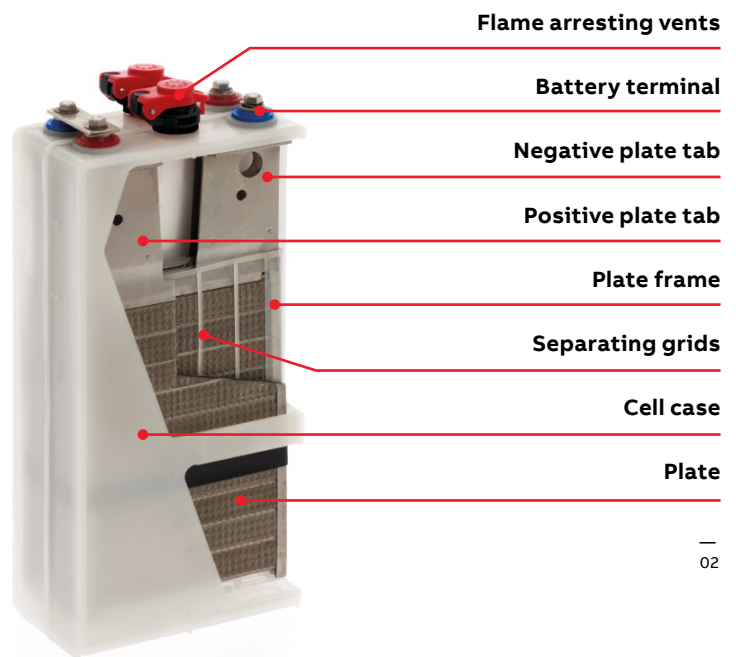

—
02

—
01 Different types of
lithium-ion batteries

Lithium-ion batteries

In a lithium-ion battery (LIB), the "cathode" is usually made of a metal oxide, while the anode is usually porous carbon graphite. Both are immersed in a liquid electrolyte made of lithium salt and organic solvent. During discharge, the ions flow from the anode to the cathode through the electrolyte and separator; charging reverses the direction, and the ions flow from the cathode to the anode.

A common way to distinguish the main different types of lithium-ion batteries is to consider the cathode composition. The choice of battery depends on various factors, including cell voltage, capacity, energy and power capabilities, cycle life, and temperature of operation.

Various LIB chemistries exist, which can be simplified into six main types based on the composition of the cathode material (items 1 to 5) or anode material (item 6):

1. Lithium cobalt oxide (LCO)
2. Lithium manganese oxide (LMO)
3. Lithium-nickel manganese cobalt oxide (NMC)
4. Lithium iron phosphate (LFP)
5. Nickel cobalt alumina (NCA)
6. Lithium titanium oxide (LTO)

It is not possible to compare these different families precisely, since many aspects other than technology play an important role in performance, such as mechanical form, cell size and active material mix. Different battery manufacturers also combine technologies to improve performance for a specific application.

—
01

LCO

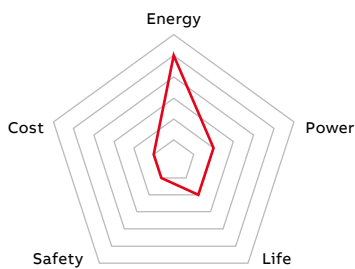

NCA

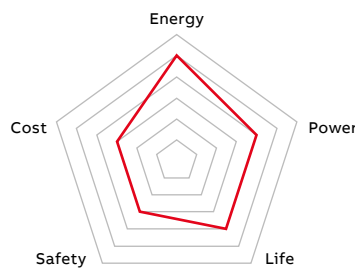

NMC

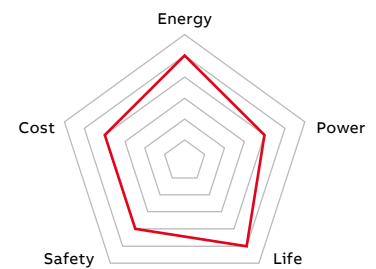

LMO

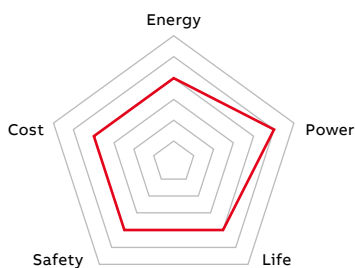

LFP

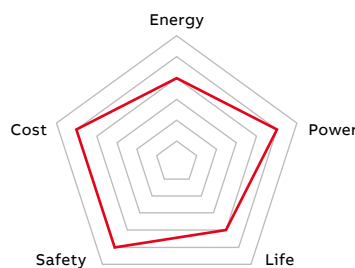

LTO

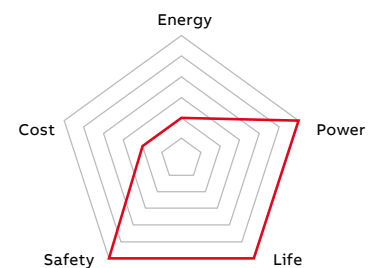



The chemistries mostly used for UPS applications are LMO-NMC and LFP because of their long calendar life, high safety and high power density.

ABB's first choice for battery technology is an LIB cabinet solution with a special combination of lithium manganese oxide and nickel manganese cobalt capable of providing over 200 kilowatts of continuous power for several minutes.

The next part of this handbook mainly focuses on traditional VRLA batteries, since they are most common in UPS applications.

Battery capacity and C-rate

The nominal capacity (KN) of a battery is the guaranteed capacity when discharging over a specified discharge current (IN) for a certain duration (nominal discharge duration, tN), at nominal temperature, nominal density and nominal electrolyte level, without failing to achieve the final discharge voltage (UsN). The nominal battery capacity can, therefore, be expressed as $KN = IN \times tN$.

The nominal capacity values (in ampere-hours) set by battery manufacturers typically refer to a ten-hour discharge (C/10) of a lead battery and a five-hour discharge (C/5) of a NiCd battery. In UPS system applications, the real usable, extractable capacity is significantly lower than the nominal capacity due to the shorter discharge duration. The amount of power requested within the specific autonomy time are major factors that impact battery sizing.

Battery sizing

01 Impact of operating temperature on battery life

Sizing the batteries normally starts with two major requirements: power and autonomy. The power value to consider is the one coming out from the batteries, so the calculation should start with the load power and consider the power factor and inverter efficiency.

$$P_{\text{bat_out_}} = (P_{\text{load}} \times \cos\Phi) / \text{Ups}_{\text{efficiency}}$$

There are two main methodologies for proper battery sizing. One option is to refer to battery performance sheets that give details on autonomy values under different constant power/current discharge characteristics versus temperature and cutoff voltage limits.

The other option is to use the ABB battery configurator tool or the online battery configurators available on suppliers' websites.

It is important to make sure that each system uses only one battery model, and that there are never more than four to five strings in parallel per system. (This is the best practice, but it may vary depending on the recommendations given by battery manufacturers.)

Major aspects of battery selection to be carefully considered are:

- Battery life
- Performance at beginning or end of life (BOL or EOL)
- Operating temperature
- Depth of discharge
- Cutoff voltage
- Charging time

Operating temperature

Operating temperature has a strong impact on battery life and performance. All major manufacturers recommend operating their batteries at 20–25 °C.

Higher temperature values increase battery performance but decrease battery lifespan. According to the Arrhenius law, battery life is halved for each 10 °C increase above the 20–25 °C range.

Battery manufacturers provide battery performance sheets for the specific operating temperature.

01

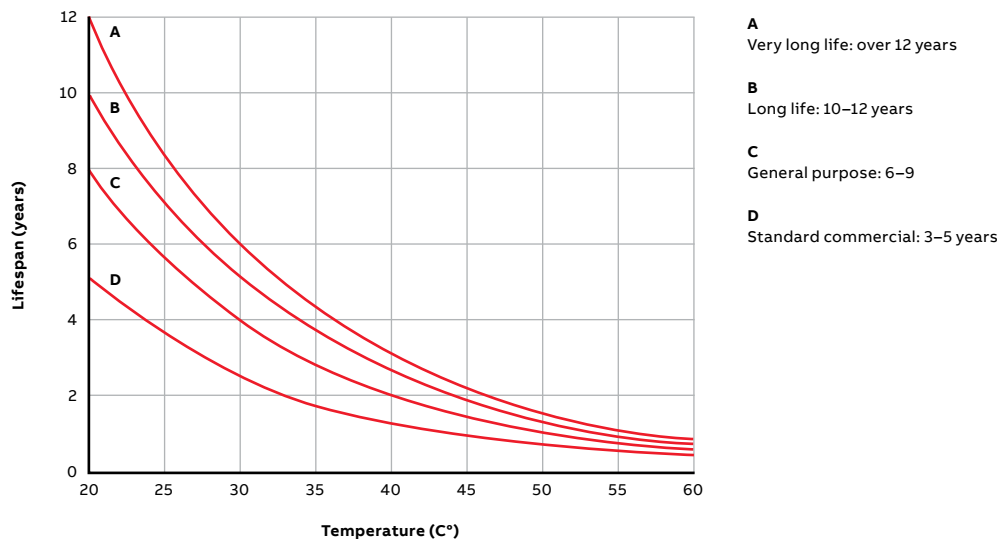

Battery life

A battery type consistent with the lifespan required by the project specifications should be chosen. All major battery manufacturers' products are categorized by lifespan. Eurobat provides a clear picture of the four main categories:

- Standard commercial: 3–5 years
- General purpose: 6–9 years
- Long life: 10–12 years
- Very long life: over 12 years

Battery lifespan depends on various factors, and real service life may differ significantly from the original design life specified by manufacturers -- in most cases (e.g. where temperature is higher than nominal), it is 50 to 70 percent less.

Beginning- and end-of-life performance

Customer specifications may require a specific level of performance (e.g., power and autonomy) from batteries at their beginning of life (BOL) or end of life (EOL). Battery sizing must include an oversizing factor (typically 125 percent as for IEEE485) to account for aging in the case of an EOL requirement.

Depth of discharge (DOD)

Batteries can be discharged completely or partially. The less (state of charge) a battery discharges per cycle, the lower the number of cycles that the battery will provide during its entire life.

The number of cycles is normally not so pertinent for UPS systems, since they normally utilize the batteries just a few times a year. However, in some cases, and for specific countries, this aspect may be more relevant. The following graph shows typical discharge/lifetime behavior for VRLA batteries used in UPS applications.

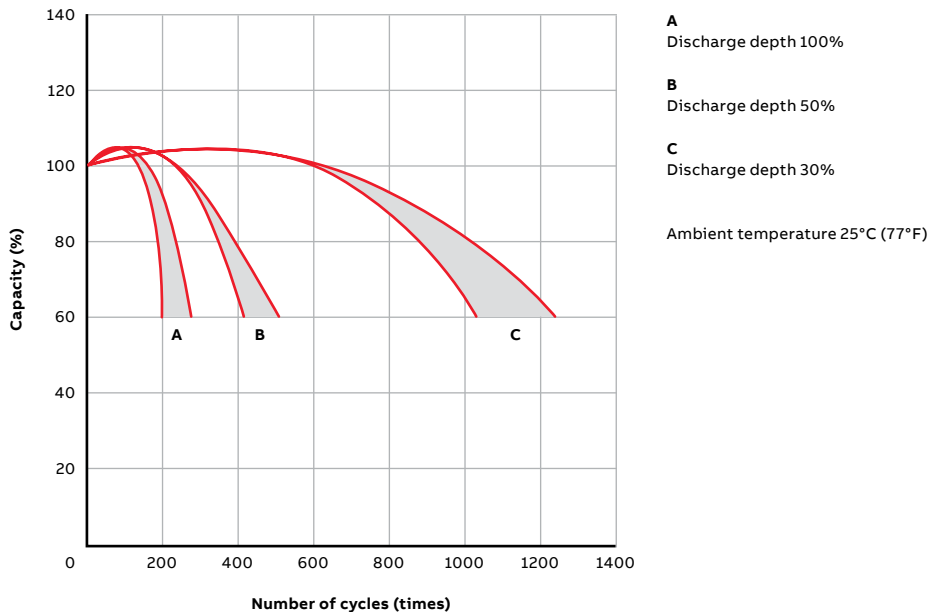

01 Floating charge at constant voltage

Cutoff voltage

The lower the cutoff voltage is, the more power a battery can deliver. All battery manufacturers declare battery performance relating to cutoff voltage limit.

When sizing a battery system, it is important to consider the minimum cutoff voltage per cell (e.g., 1.65 V per cell, 1.7 V per cell, etc.). Normally, the project specifications indicate the requirement for this value. It is also very important to verify that the DC battery voltage range of the selected UPS is compatible with the calculated number of battery blocks.

If batteries ever discharge below their minimum cutoff voltage, they are considered to be over-discharged. In such a case, internal resistance increases due to plate sulfation, and both capacity and life decrease dramatically.

Charging time

Charging time depends on the maximum power that a battery can accept without jeopardizing its lifespan.

For LA batteries, charging power and voltage are normally sized to provide a maximum current of C/10 (a charge rate in amperes of one-tenth the overall battery capacity in ampere-hours), with a constant current and constant voltage charging methodology. In some cases where long autonomies are required, it is also very important to verify that the UPS charging power is sufficient to ensure proper battery charging within the required time.

The DC charging voltage must be ripple-free, since this may strongly affect battery life. This voltage must also stay within the range specified for the particular battery: with a higher charging voltage, the internal pressure in the battery will increase and force open the valve to allow gas to escape. Overcharging like this will corrode the positive plate, shortening the battery life.

01

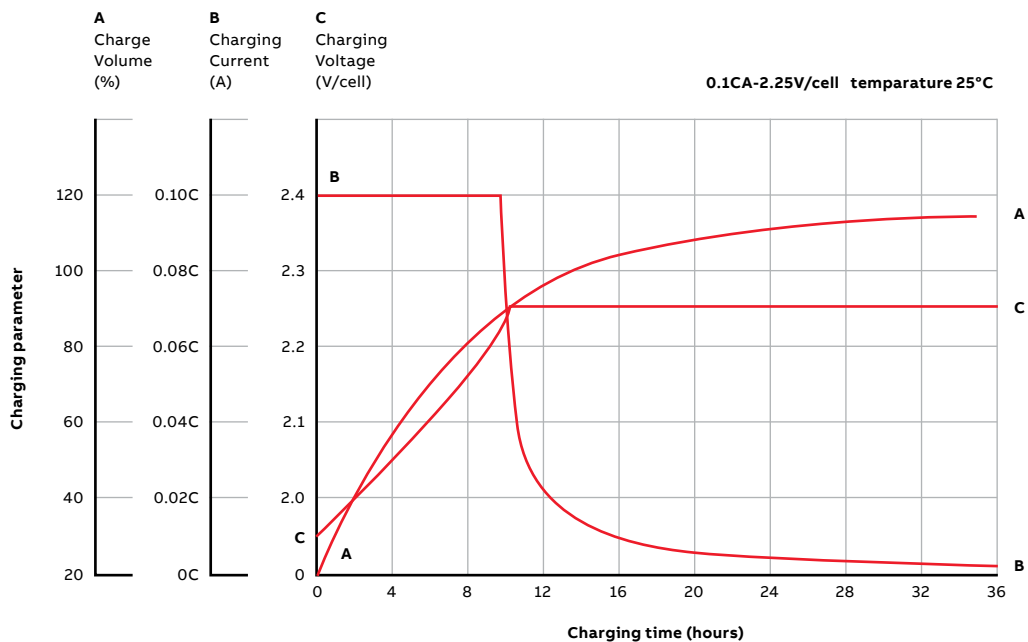

Main causes of failure

Battery failure is the cause of 50 to 70 percent of UPS outages. Other than short circuits, there are three main mechanisms (excluding external and internal short circuits) that reduce VRLA battery life and performance:

Plate corrosion

Plate corrosion is usually the result of oxygenation of the positive plate. It reduces the amount of active material that can participate in chemical reactions, reducing battery performance and life. This factor is unavoidable. A battery that reaches end of life through this failure mode has met or exceeded its anticipated lifetime. Limiting the depth of discharge, reducing the cycle count, operating at moderate temperatures and controlling overcharge are preventive measures that keep plate corrosion under control.

Dry-out

“Dry-out” means a decrease in electrolyte quantity, which strongly impacts battery life and performance. The main reasons for battery dry-out are excessive temperatures and overcharging. With a higher charging voltage or current, the in-

ternal rate of gas recombination is not enough to compensate for the large amount of hydrogen and oxygen generated. This leads to an internal overpressure, which causes the relief valve to open. In a VRLA, the electrolyte lost to the environment cannot be recovered, strongly affecting battery performance and life. In the worst case, it may result in thermal runaway, or even in a fire or explosion.

Sulfation

In normal chemical reactions when a VRLA discharges, lead sulfate crystals are deposited on the plates. In charge mode, they are converted back to active materials. If batteries remain empty or only partially charged for a certain period, these lead sulfate crystals harden, and it is not possible to convert them back to lead or lead oxide during charging. This strongly impacts battery performance, life and capacity, so it is important to fully charge batteries after each discharge and to follow the battery manufacturer’s instructions on proper charging voltage settings, since a charging voltage that is only slightly lower than specified may still cause this issue.



Storage

01 Capacity retention characteristic diagram

VRLA batteries discharge themselves, so their available capacity decreases even when they are not operating. VRLA batteries must be stored fully charged, in their original packaging, and in a dry, clean and well-ventilated environment. There should be no visible traces of acid on their cases. Do not stack different pallets or batteries on top of each other unless instructed to so by the manufacturer.

As a rule, inside buildings, flooded batteries should be stored on liquid-proof ground with acid collection trays. For VRLA cells/blocks, an acid collection tray is not necessary. Batteries must be well protected from metallic parts that may cause short circuits, and be guarded against accidental damage and falling objects.

During storage, batteries must be correctly managed. After a certain period has elapsed since a battery's production date or most recent charging, the battery needs to be recharged according to the manufacturer's instructions. This period depends on aspects like storage temperature, battery model, etc. Higher ambient temperatures decrease the time allowed between charges. For this reason, the supplier's recommendations for the specific battery model should always be followed. It is also common to measure the battery's open-circuit voltage and postpone the charging process in cases where measurement results are higher than the limits.

01

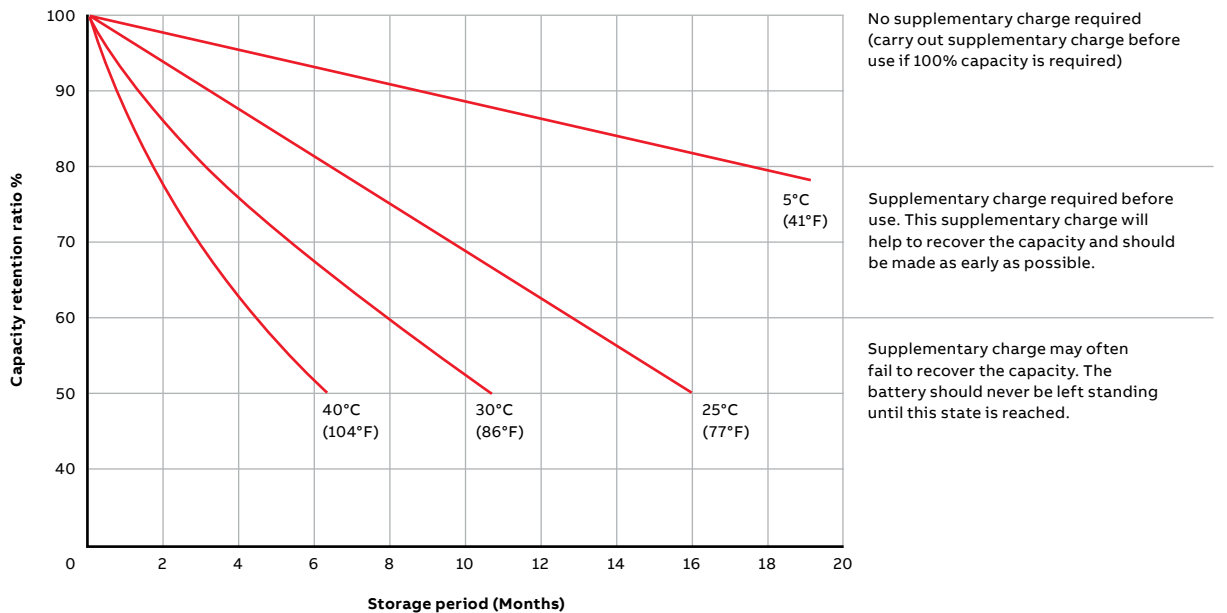

Maintenance and battery monitoring

VRLA batteries do not need to be topped up with water like the flooded type does, but the following steps are important in order to ensure longer battery life and stable performance:

- Check battery voltage and temperature and verify that all connections are free of dust (never use solvents to clean batteries; a damp cloth is enough), corrosion or leakage. Check that the ventilation is working and that all connections are tight and fastened. This last check may be also done with a thermal scan while the batteries are operating, as bad connections are usually the site of hotspots.
- Perform a battery discharge test at least once a year to evaluate the battery's internal resistance and available capacity on all connected blocks. This specific test must be agreed to, and confirmed by, the customer, since the load may not be fully covered while this test is being run. To simplify this test, ABB has developed the AKKA diagnostic tool, which provides connections as well as acquisition systems to measure the most relevant battery parameters and detect weak batteries that may need replacing.

Any damaged batteries must be replaced with one with a similar internal resistance. Normally, this is possible in the first two to three years of operation, depending on battery type. After that, the replacement should be a used battery of a similar age. If such "aged" spare parts are unavailable and the UPS cannot operate with a reduced number of batteries per string, the entire string of batteries must be replaced.

To reduce the required maintenance work, a battery monitoring system can be used. Many systems are already available and used in the field in ABB UPS applications. These tools continuously monitor battery parameters such as voltage, current, temperature and internal resistance, providing real-time alerts and warnings. They also offer full data acquisition packages and tools for proper analysis and metrics. These systems usually also offer thermal runaway control and remote monitoring features, and in some cases even active balancing between batteries.

The capex costs for such systems are quite high, but – more notably than all the functionalities described below – they provide the very important benefit of advance warning of which battery is going to fail so it can be promptly replaced, avoiding unexpected outages.



Ventilation and safety

Irrespective of whether they are sealed or not, all lead-acid batteries can emit explosive gases – especially while charging – so adequate ventilation is mandatory (hydrogen gas emitted during charging is explosive at concentrations above 4 percent). Hydrogen and oxygen gases may also be released if, for example, if the battery is moved or shaken.

In order to dilute gases (hydrogen and oxygen) generated during charging and discharging - and thus eliminate the risk of explosion - battery rooms must be ventilated in accordance with the EN 50272-2 standard. Such ventilation obviates the need for EX-proof electrical equipment. The ventilation system must be designed to cope with wet-room conditions.

Do not install batteries in airtight enclosures! Spark-generating parts must be installed with a safety distance to cell or battery block.

Ventilation requirements

EN 50272-2 states, the minimum air flow rate for ventilation of a battery location or compartment shall be calculated by the following formula:

$$Q = 0.05 \times n \times I_{gas} \times C_{rt} \times 10^{-3} \text{ [m}^3\text{/h]}$$

With

N = number of cells

$I_{gas} = I_{float\ or\ boost}$ [mA/Ah] relevant for calculation (see table below)

C_{rt} = capacity C_{10} for lead acid cells (Ah),

$U_f = 1.80$ V/cell at 20°C”

The following table states the values for I_{gas} to be used:

Operation	Vented cells (Sb < 3%)	VRLA cells
Float charging	5	1

I_{gas} according to EN 50272-2 for IU and U-charging depending on operation and lead-acid battery type (up to 40°C operating temperature). The gas-producing current, I_{gas} can be reduced to 50 percent of the values for vented cells where re-combination vent plugs (catalyst) are used. With natural ventilation (air convection), the minimum inlet and outlet areas are given by:
 $A \geq 28 \times Q$ [cm²]
 (Air convection speed ≥ 0.1 m/s)

For more details on how to size the ventilation system for a battery room properly, refer to specific international and national standards (e.g., BS EN 502720-2:2001).



Recycling and disposal

01 At the recycling facility, used batteries are broken apart and separated into components to begin the recycling process.

Nearly 100 percent of lead–acid batteries are recycled. There are two main reasons for this: Recycling lead is cheaper than obtaining new raw material, and all the parts of the battery can be completely recycled.

Polypropylene is recycled into more battery plastic to produce new battery cases, sulfuric acid is collected and resold as commodity acid, and lead is smelted and reused in batteries or other products.

The lead–acid recycling system is ecologically almost a closed loop, and it is highly regulated at the local, state, national, and international levels. Battery owners can safely dispose of their spent batteries at retailers and recycling drop off centers – or even return them directly to the manufacturer, some of whom provide this service for free.

For proper battery disposal, refer to national/international legislation and local waste disposal rules and regulations.

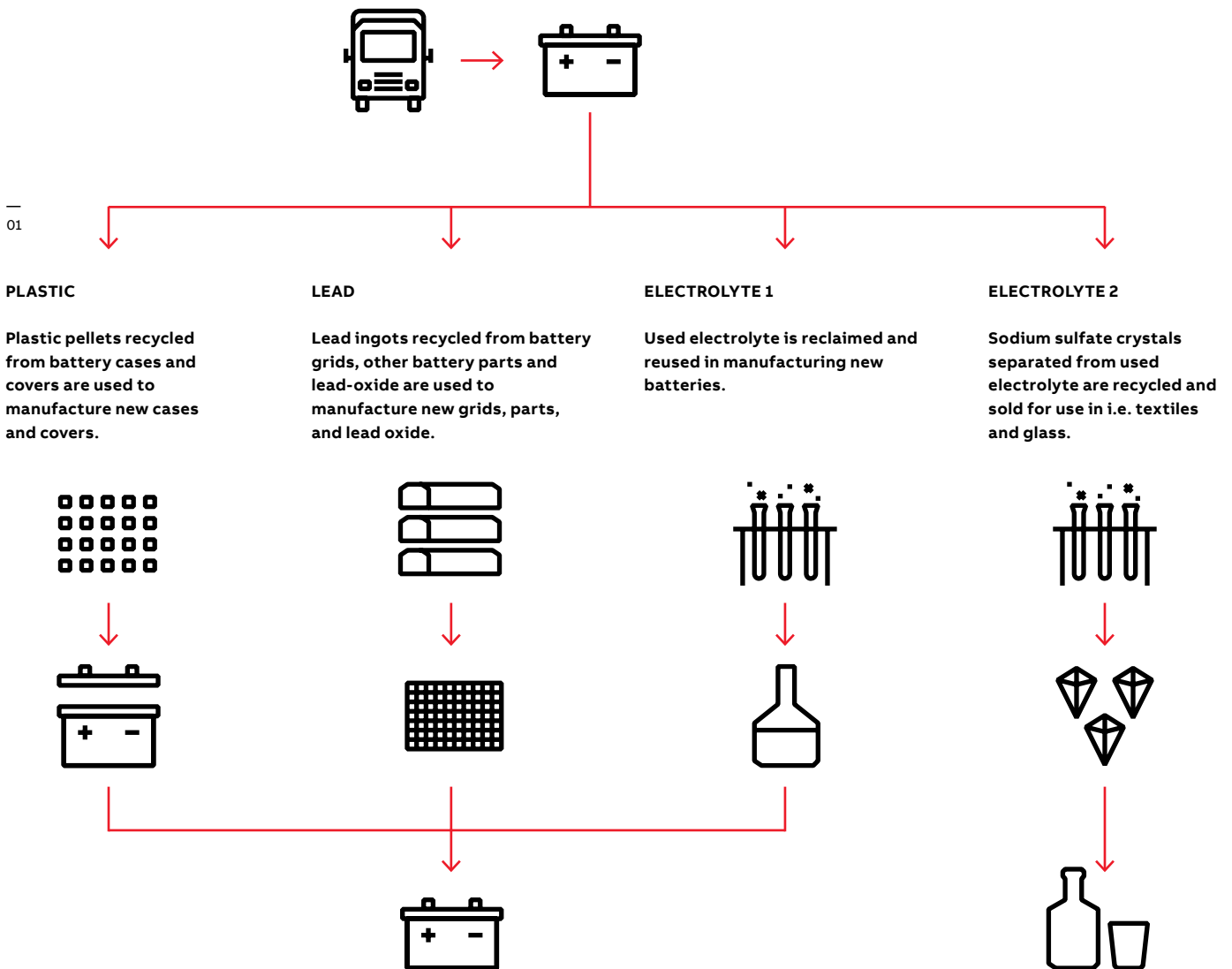

—
www.abb.com/ups
ups.sales@ch.abb.com



© Copyright 2017 ABB. All rights reserved.
Specifications subject to change without notice.

4NWP101121R0001 EN

